

THE ART OF FRETWORK

6^d

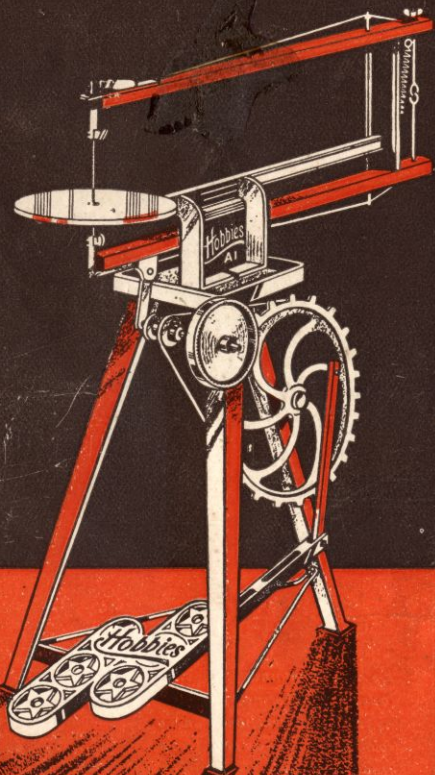

HOBBIES

All the Tools you require

There is no more fascinating pastime than Fretwork, but it cannot be thoroughly enjoyed unless you have reliable and serviceable tools. Hobbies have made them now for over 40 years, and are proud of what they make.

HOBBIES

BRITISH FRETWORK OUTFITS



CARDED OUTFITS

Each one containing sufficient tools for the beginner, as well as printed instructions and a coloured design pasted on wood ready to cut out.



There is a range of Outfits to suit all pockets, and each contains sufficient tools to make a start. The strong hinged boxes form permanent tool racks or chests and every tool is guaranteed of good quality. These Outfits offer the simplest way of starting and form a compact but handy set of tools for the beginner.

OUTFITS FOR ALL PURSES

ILLUSTRATED PRICE LISTS
FREE ON APPLICATION

THE A1 OUTFIT

A wide range of tools, as well as designs and planed wood for making six simple, useful articles. Outfit includes a 14" Lever Hand-frame Archimedeian Drill with two Bits, Cutting Table, 2 doz. Hobbies Sawblades, Plane, Fretwork Hammer, Glass-paper Block and Illustrated Handbook.

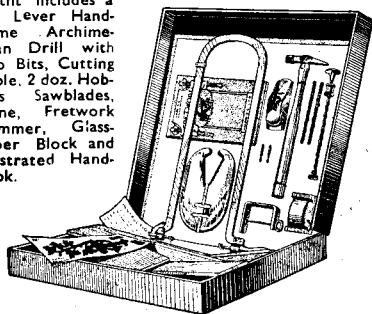

HOBBIES, Ltd., DEREHAM, NORFOLK
and Ironmongers, Stores and Agencies everywhere.

THE ART OF FRETWORK

A fully illustrated and instructive book
on a fascinating and enjoyable hobby
for craftsmen of any age.



**HOBBIES LTD
DEREHAM AND LONDON**

CONTENTS

THE NECESSARY TOOLS - - - - - Page 8

The Points of a Handframe—Drills—Tables—
Tightening the sawblade—Size of Handframe—
Notes on Sawblades and Cutting—Glasspaper.

WOOD AND PATTERNS - - - - - Page 17

Varieties of Wood—The Best to Use—Measuring
a Square Foot—Preventing Warping—Simple and
Elaborate Patterns—How to save Wood—Direc-
tion of Grain—Pasting down the Patterns—Hints
on Fixing.

CUTTING OUT THE WORK - - - - - Page 23

Elementary Exercises—Practical Cutting—Vertical
Cutting—How to cut Angles and Curves—
Turning the Blade—Right-Angle Corners—Connect-
ing link Styles—Figure Features—Order of
Cutting.

CONSTRUCTION DETAILS - - - - - Page 31

Various joints in use—The Butt Joint—The
Halving Joint—Mortise and Tenon—Dowel Joints—
How to cut—Gluing the parts—Dovetailing,
Shaping and Chamfering—Use of File and Glass-
paper—Special Nails and Screws—Methods of
Fixing Overlays.

MODEL MAKING - - - - - Page 41

Tools and Types—Points to Note—Fitting Wheels
—Suitable Cover Papers—Paints and Enamels for
Finishing.

CONTENTS—Continued.

INLAID WORK - - - - - Page 44

Two Types—With two kinds of Wood—With four varieties—Butting out the Parts—Fitting to a Picture—Complete Panels—Gluing up—Outline last.

SUITABLE FINISHES - - - - - Page 48

Two kinds of Dye—Water and Spirit—The Best to Use—Staining to colour—Polishing—Dull Finishing—Use of Linseed Oil.

USE OF FRETMACHINES - - - - - Page 51

Both Hands to Operate the Work—Choice of Machines—Treadling—Practise Oiling the Parts—Loose Belts—Automatic Drilling and Glass-papering.

DISPOSAL OF WORK - - - - - Page 55

Samples to Show—Varieties which are Popular—Toys and Models—Shops and Friends—Questions of Price—Special Occasions.

HOBBIES CLUB - - - - - Page 58

How to Form—Books to Keep—Work to Undertake—Subscriptions and Officers—The Workshop.

THE HOBBIES LEAGUE AND HOBBIES WEEKLY Page 61

Advantage to Members—Certificate and Badge—Clubs and Pen Friends—Free Designs—Practical Articles—Advice to Readers.

THE ART OF ARTWORK

A PLEASING
PRACTICAL
PROFITABLE
PASTIME

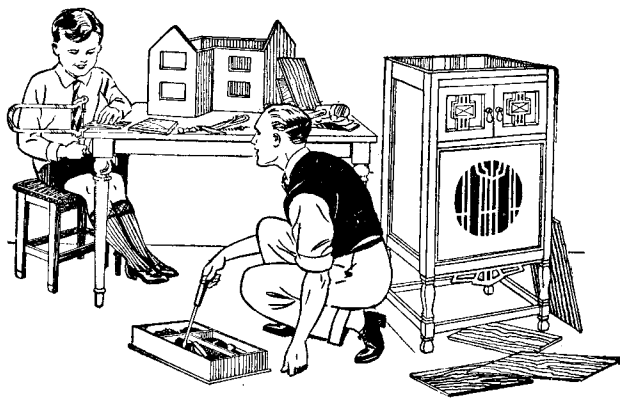

THERE is all over the world, an increasing number of people who are realising the value of the fretsaw, and to what a wide range of work it can be put. Whilst primarily intended for the beginner, this Handbook will undoubtedly be a source of interest and instruction to those who are more experienced, because it contains a large number of practical hints and tips which have been gathered as the result of the manufacture and experience of 40 years in fretwork.

The book is written in non-technical language and covers the whole of the needs of the fretworker, giving instruction in the general use of tools in the more advanced work, and numerous hints on how to dispose of your work when completed. Fretwork has the big advantage that it requires few tools to begin with, then one can immediately start to use them in turning out some practical or useful piece of work.

These classes of work can be divided into the purely ornamental, and the purely useful. Right through, examples of these are given and, of course, a very much wider range is shown in the current Hobbies Handbook which is an Annual as necessary to any worker as this book.

THE NECESSARY TOOLS

THE use of the fretsaw demands no great knowledge or theoretical exercises first. As soon as one has a set of tools one can begin work, and so gradually improve and grow in utility and enthusiasm.

The tools can be useful for pleasure or profit, too. You can cut out a few simple toys for the kiddies to play with, or you may make it a profitable industry in your spare time or even earn a useful living, as so many unfortunately unemployed are doing.

The use of the fretsaw, as we have seen, is almost universal, and before going further, it is essential to show that "fretwork" in itself is a misnomer.

Years ago it was the name given to the cutting of an amazing number of frets in a piece of wood of doubtful usefulness or beauty. Since then the work has become an art which has extended to all the facets of woodwork generally.

And not only woodwork, for the fretsaw can be used in wireless on ebonite; in metal work on silver, zinc, brass and aluminium; in fancy material such as celluloid, ivorine bakelite, etc., in leatherwork for ornamenting other work; and even tailoring in the cutting of cloth or woven materials.

One great point to remember is—do not buy a large number of inferior, cheap and comparatively useless tools. The pastime has the advantage that you need but very few to make a start and can add as you proceed. Let those few, however, be worth while, guaranteed to give you service, to do the work required of them.

Do not be put off with a cheap frame or cheap blades. You will only begin to regret the step as soon as you begin work because neither will turn out jobs which will do you credit.

Naturally we say buy Hobbies. Not merely because we want you to do good work, but because we know they are made of sound materials, put together by skilled workmen and tested by qualified inspectors.

The point is well worth considerable consideration by those readers who are beginning fretwork. Others who have become more or less expert in the art, will possibly have learned this lesson for themselves.

Now for the principal requirements. The first essential is a handframe with some spare sawblades, and more details of these will be given later because they are the most important part of our equipment.

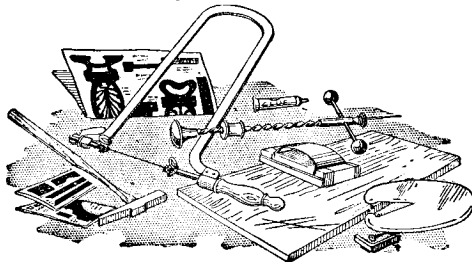

The saw frame, obviously, cannot be used on the edge of a bench or table, and a special cutting table is necessary. They vary in shape and style as shown in the illustrations, but the ruling principle of each is that it must have a V-shaped opening in which the saw can operate whilst the work itself is held down to the table.

The Drill

Then comes a drill—of a special design known as an archimedean drill. The name may sound strange, but it merely comes from the form of screw originated by Archimedes, a celebrated engineer living 200 years B.C. He used a screw machine something like a huge drilling bit, and by rotating it raised water to the levels he required.

A sharp pointed steel bit is put in the end, and the rotating screw turned so rapidly that a tiny hole is made without much effort.

The drill is used, of course, to make the hole through which the saw-blade is threaded before being replaced in the frame.

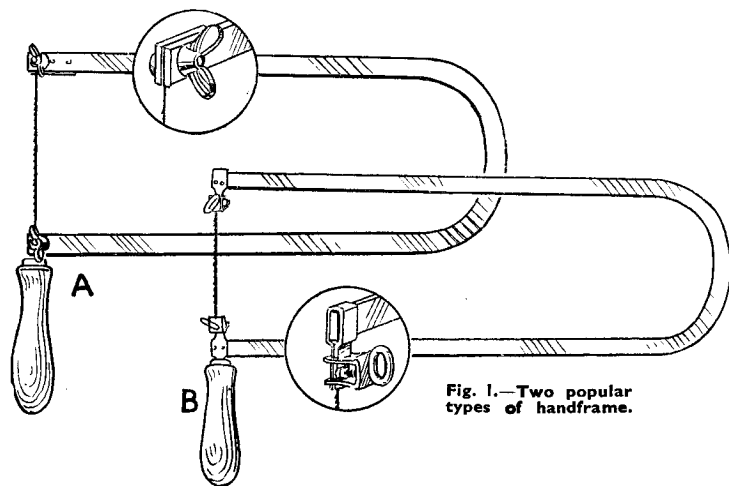

Fig. 1.—Two popular types of handframe.

Another essential accessory is glasspaper with which to clean up the work and take away the pattern paper remains.

Small files are also useful for the same purpose, but the experienced worker is able to do without them.

In addition, one has to have paste to fix the patterns to the wood, glue to hold the parts together, as well, of course, as the wood and necessary designs themselves.

These, then, are the essential tools, and we can describe them more fully now, explaining their uses and good points and then passing on later to the other tools which can be added.

The question arises, of course, of the owner of a machine, and we shall later devote a special chapter to the many little points which the worker should know.

Then there is the matter of wood, and on this also, we shall be able to give much useful information.

The first tool to consider is the handframe, and here, as in all tools, the worker should buy the best he can afford. There is much variety in these, each style having its own points of advantage.

Each one, of course, consists of a steel frame with a comfortable handle, and is fitted with grips or clamps which hold the tiny sawblade.

The cheapest form is illustrated at A in Fig. 1, and here we have simple wing nuts which act on a plate to grip the saw.

In B type is illustrated a much better grip originated by Hobbies Ltd., and acknowledged to be the best. This is a screw and shackle and the action is such that both sides of the shackle spring together as the screw is turned, thus getting an even grip of the end of the blade. The blade is held in a grip which cannot fail, and yet the action of tightening is simple.

Blade Tension

It is actually the tension of the sawblade which provides for the cutting. A tight sawblade is essential and, therefore, a good grip is equally important. About $\frac{1}{2}$ in. of the end of the blade is inserted into the grip before the screw is tightened.

The steel arms of the frame give to a certain extent, and they should be pressed together slightly when the sawblade is fixed. Then when released, the arm springs out, and makes the blade taut. The method of fixing the bottom end of the sawblade in first and then pressing the top arm down, is shown in Fig. 2.

It is impossible to tell you the exact tension as this is only known by experience. One must remember that it is almost impossible to get a blade too tight—the beginner usually has it too slack.

A Simple Test

A good plan is to grip the saw in the frame between the finger and thumb, stretch it slightly as in Fig. 3, and then let it go quickly. It should fly back straight with a "ping," a high sounding note much as a violin string would.

This matter of tensioning a sawblade is very important because a slack saw will snap quicker than a tight one. It is, indeed, one of the failings of the beginner that he complains of breaking many blades, when it is largely his own fault.

To overcome this trouble, and simplify the matter, a special device



Fig. 2.—How to fix the sawblade.

was patented by Hobbies whereby a system of levers does the work quickly and easily. This device is featured in the Lever frames, and purchasers will do well to note them.

An eccentric lever is provided on the top of the arm, and this is thrown forward before the saw is put in. There is thus no need to press the two arms together because the lever provides the tension. With the blade fixed in the cramp, the lever is thrown back. The action of the cam forces the arm down slightly, but as this has a spring-open tendency, the sawblade is held quite tightly. The action is shown clearly in Fig. 4, where the first picture is of the blade as inserted, and the second the lever is thrown back into position and tightens the blade.

Three-Lever Action

An extension of this principle is seen in the latest handframe, where a double action is provided on the top arm and another on the bottom. This is the Triplex Frame, and the details at Fig. 5 illustrate this clearly. The third lever is provided by the screw at the bottom end of the saw.

In this frame it is interesting to note the shape of the handle, which has been evolved to prevent undue strain on the wrist. The hand grips this shape quite comfortably, and is the more liable to hold the frame upright, and without the tendency to let the back of the frame sag.

We must not omit to point out to the reader the advantages of the latest type to be produced, illustrated at Fig. 6. and called the Toggle Lever Frame.

The toggle, it may be noted, is the name given to an appliance for transmitting force at right-angles to its direction and a glance at the illustration shows how this is effected in the use of the frame.

The handle is pivoted (which incidentally allows it to be folded into much smaller compass) at the point marked A. The saw grip (of the spring-open

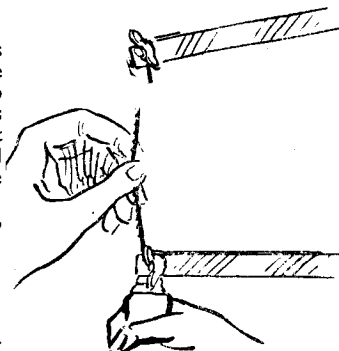

Fig. 3.—How to test the blade.

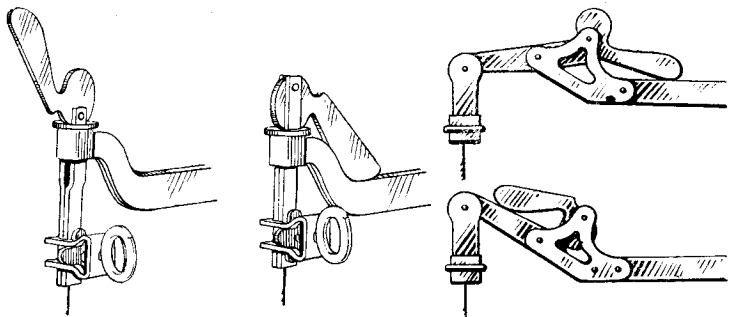
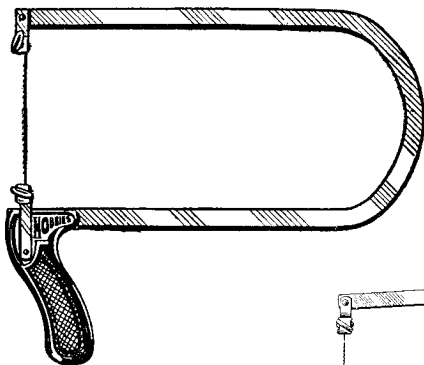

Fig. 4.—A simple lever tightening device. Fig. 5.—The action on the Triplex Frame.

type already described) is also pivoted at B, and in Fig. 6 the angle at which the blade is inserted is shown. This is quite a simple operation for the frame does not have to be sprung as in the ordinary type.

About $\frac{1}{2}$ in. of the blade is inserted in each of the clamps with the saw taut, as shown. It must be put in quite tightly to withstand the tension made by the handle turning to its proper cutting position. It is merely, and easily, pressed downwards to follow the direction indicated by the dotted lines. In so doing, it forces the arms of the frame together and so makes a simple and satisfactory tension on the blade.



A word or two on sizes of frames generally may be helpful. They are given in the catalogues varying from 9 ins. to 16 ins., and this measurement is the actual distance between the saw-blade and the back of the frame at its deepest point.

This means that if you have a 12 in. frame you can cut a piece of wood just 12 ins. long without the necessity for turning or withdrawing. With a 16 in. frame you can go 16 ins. into a board, and so on.

Now, the most popular size is the 14 in. for this will allow cutting all the normal work the beginner is likely to need.

Of course, the larger the frame the heavier its weight, and a good plan is to have two frames,—one for small cutting and one for large work. In that case it is advisable to have a 12 in. frame for general use, and a 16 in. frame for occasions when large cutting is undertaken.

It must be remembered, too, that although a 12 in. frame will cut that distance straight, the saw cannot be turned because the metal is close up to the wood. A certain distance must be allowed for turning or sweeping, and this, of course, depends on the width of the work.

The Toggle

This Toggle Frame is certainly an advance on its predecessors because of the ease with which the correct saw tension can be obtained. The ordinary handle is a metal one, but the frame can be obtained with a handsome and comfortable bakelite handle, as is illustrated at Fig. 6. These are manufactured only by Hobbies Ltd.

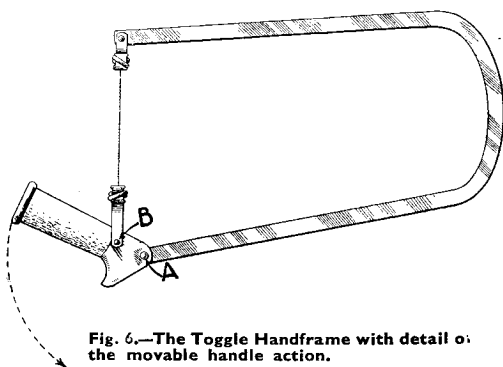

Fig. 6.—The Toggle Handframe with detail of the movable handle action.

All the same, it is always possible to compromise because there is the opportunity of cutting from *both* ends of the work. Having gone as far as possible into the part from one way, the board can be turned and a start made from the opposite way until the cuts join.

From the handframe, we turn to the sawblade itself. This is a thin piece of steel on which a number of teeth are cut in the same way as an ordinary tenon saw. Each blade, if properly made, goes through half a dozen different

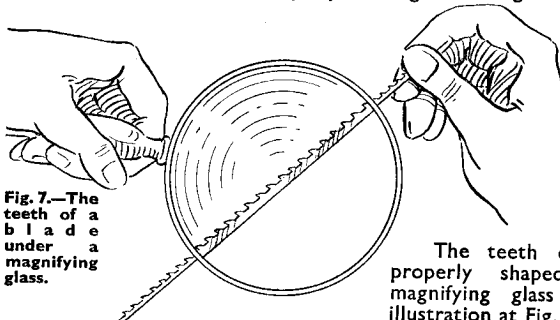

Fig. 7.—The teeth of a blade under a magnifying glass.

processes before it attains perfection, and visitors to Hobbies Works are always most impressed by the clever and intricate machinery which is needed at each stage.

The teeth of the blade are properly shaped, and under a magnifying glass look like the illustration at Fig. 7.

The teeth point in one direction, and although it cannot easily be seen, one can always tell which it is by running the blade along between the finger and thumb (see Fig. 8). The cutting is always done on the down stroke so the blade must be inserted in the frame with the teeth pointing downwards.

As previously mentioned, there are various grades varying from No. 00 to No. 6 in the popular make. These grades are worth noting, for obviously, it is asking for breakages to use a very fine blade (00) on a coarse and thick piece of wood. That size is used on thin and fine work, and a coarse blade (No. 5 or 6) on rough work.

For General Use

The best all-round size for general usage is the No. 1 or 2, but the keen worker will have a selection of fine, medium and coarse, so he can accommodate them to the work in hand.

It may seem to the beginner that sawblades are always breaking. He gets a little tired of having them snap, and is apt to believe it a costly and troublesome business.

But that is only because he *is* a beginner. As he learns the proper tension and pressure, he will reduce his breakages. Very soon he will be able to do quite a lot of work without a single broken blade.

The trouble of the beginner is usually that he is intoo much of a hurry. He presses his blade through the wood

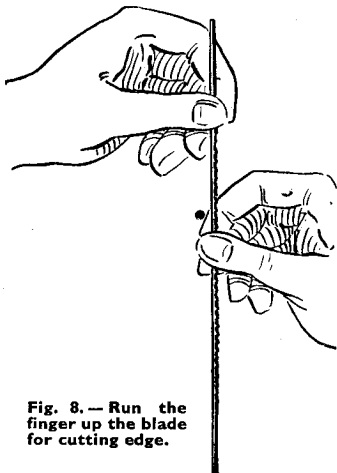

Fig. 8.—Run the finger up the blade for cutting edge.

so it takes the shape shown at Fig. 9. The more he presses forward the greater the strain, until, of course, the saw snaps.

The cutting is done by a rapid up and down motion. Hold the work firmly to the special cutting table (about which, more later). The actual speed of the motion cannot be explained but it should be fairly rapid, particularly when turning the saw in the wood.

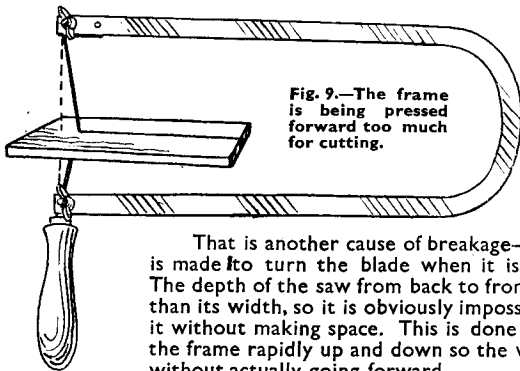

Fig. 9.—The frame is being pressed forward too much for cutting.

That is another cause of breakage—an attempt is made to turn the blade when it is stationary. The depth of the saw from back to front is greater than its width, so it is obviously impossible to turn it without making space. This is done by moving the frame rapidly up and down so the wood turns without actually going forward.

Altering the Blade

It sometimes happens that the saw, for no apparent reason, will not cut straight in line with the frame, but deviates to the right or left. This is probably caused by the teeth portion of the blade having been turned to a different angle from that portion held in the clamps each end.

This little trouble is easily overcome. Mark a straight pencil line on a piece of wood and notice which side the saw runs off. Then grip the ends of the blade near the clamp with a pair of flat nosed pliers, and turn gently to get the blade straight. (See Fig. 10).

It may be found, even with the ordinary blade, that the steel gets warm if used constantly. This does not affect the metal at all, but it may slightly burn or brown the wood. To prevent this, a simple remedy is to put a touch of candle grease or common soap on the blade.

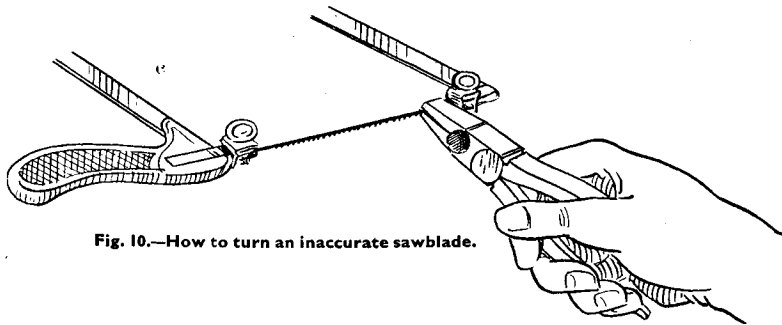

Fig. 10.—How to turn an inaccurate sawblade.

Now, all cutting must be done on a special cutting table, which allows the work to be held flat and yet provides room for the blade to do the work. A group of popular kinds are illustrated at Fig. 11, of which the most generally used, is the oval one seen on the right. This is in pressed steel, firm and rigid.

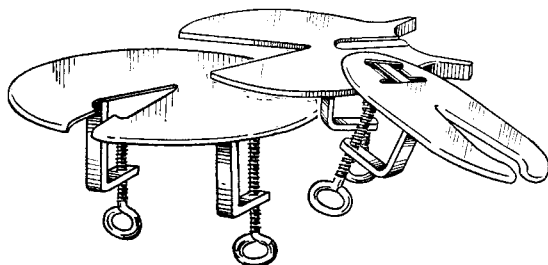

Fig. 11.—A group of various cutting tables by Hobbies.

All tables are held to the side of the bench by means of a light but strong steelcramp which is removable when not in use.

The next most important tool is the drill, and here again, there are two or three patterns obtainable (see Fig. 12). All, however, work on the same principle.

The knob at the top swivels on the stem, and a loose bobbin is provided to run up and down the twisted shank. When the drill is held on to the wood with the palm of the hand the bobbin is worked up and down. This rotates the drill bit at the bottom in one direction and so drives it gradually in to the wood, boring a tiny hole.

A failing of the beginner is to press too hard in drilling, so the bobbin cannot turn the tool. The pressure must not be heavy, and the bobbin run up and down quickly.

In extracting the drill from the wood, too, remember to turn it backwards and forwards and to draw it straight out. If this is not done, the thin bit is apt to break.

Drill Bits

The drill bits, like the sawblades, are obtainable quite cheaply and in different sizes according to the diameter of the hole to be bored.

The drill shown with the weights is a big advance on the ordinary kind, for it provides a continuous and rapid action when the drill is turned. The weights give an added momentum to the turning and a really high speed rotation results.

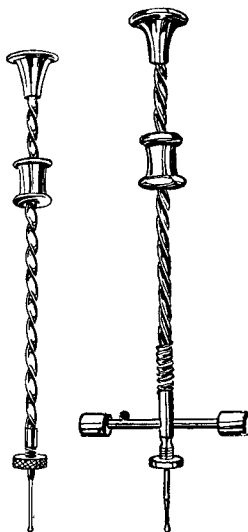

Fig. 12.—Two types of drills

Other tools which are necessary, are the hammer, a rule and a small plane. The first mentioned is much smaller than the ordinary household kind, because it is used on tiny nails or to help in the construction of putting small parts together.

The fretworker's plane, too, is quite a small tool because it is mainly used in trimming edges or tiny parts which want shaving down slightly for a joint. The one most suitable (Hobbies No. 1) is only $3\frac{1}{2}$ ins. long and has a blade $\frac{7}{8}$ in. wide. Yet it is a helpful tool of many uses as the worker will find.

A word must be said, too, about a block for glasspapering. One is supplied by Hobbies Ltd. in two sizes and is illustrated in the Hobbies Handbook. It forms a very necessary part of any worker's kit.

Grades of Paper

Glasspaper, as everyone knows, is used for cleaning the work after the pattern has been cut out, and in generally smoothing down the wood. It is supplied in various grades from OO which is very coarse to F2 which is very

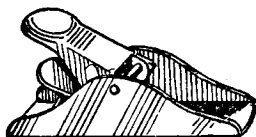

A small fretwork plane.



A fretwork hammer is small and light.

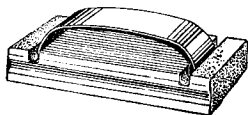

A Hobbies Glasspaper Cleaning Block.

fine. Between the two are four or five grades which are useful on special occasions. The very coarse stuff is only used on rough work, for it scratches the surface badly if used on smooth wood. The medium (No. 1) is the most generally useful, but should not be used for finishing off. The fine grade is required for that, as it does not scratch the wood, but leaves a perfectly smooth and semi-glossy surface.

WOOD AND PATTERNS

THE principal woods used in fretwork, are oak, satin walnut, mahogany, sycamore, whilst the more fancy kinds in demand are padouk, satinwood, and walnut.

It must be remembered that no two trees are exactly alike, and in consequence, the grain of no two boards is the same. They may be of the same class, but again there is a variety which can only be learned by constant experience.

300 Kinds of Oak

Again, one must remember that even in each kind there are different classes. In oak, for instance, there are over 300 different kinds known to botanists, whilst mahogany, of a totally different species, is grown in the West

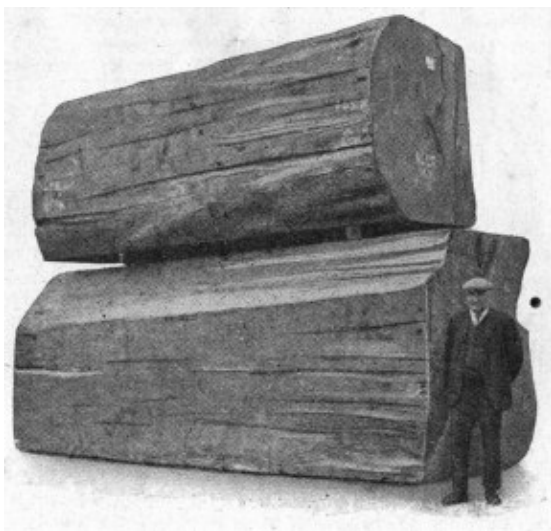

Two mahogany logs in Hobbies Timber Yard.

Indies, Honduras, Africa and India. There is, for example, Spanish Mahogany, Borneo Mahogany, St. Domingo Mahogany, as well as Colombian, Panama, East India, Mountain Mahogany, and so on.

In oak, too, there is the variety which has a nicely figured surface, or the kind which has the wide open grain so well known in furniture. Oak, of course, is essentially English, but there is also American, Austrian, African, Russian and Polish, which are often used.

In this respect, it is worth noting that although belonging to a different family, Spanish Chestnut is frequently very much like oak in looks. The material is much softer in texture, but also much cheaper, and is, therefore, often substituted, and may be passed off as oak to the uninitiated.

Varieties to Know

A full description of these timbers cannot be given here.

Most workers know the wood used varies in thickness from $1/16$ in. up to $3/8$ in. and, very occasionally, $1/2$ in. The $1/16$ in. is used mainly in inlay work or as ornamental overlays. The $1/8$ in., $3/16$ in. and $1/4$ in. are in general use, although it must be remembered that the thicker wood looks very

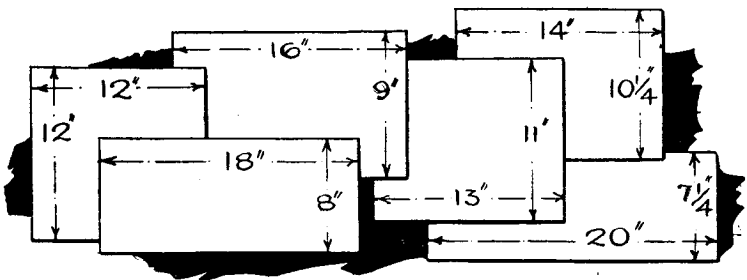

Fig. 1—Some various dimensions which make up a square foot.

heavy if it has a number of frets cut in a small piece. The $1/8$ in. stuff is used in large work and where there is strength required. It should not be fretted a great deal.

Both $3/8$ in. and $1/2$ in. boards are mainly used in furniture work, such as large cabinet tables, footstools, etc., and of course, it takes more cutting in proportion. They should not be used more than possible in ordinary small work.

All boards are now obtainable ready planed, and those offered by Hobbies Ltd., have a beautiful glossy surface which needs no further treatment. The $1/16$ in. boards are occasionally planed on one side only, but, being used for ornamental work—both sides are never used, and it does not matter in consequence.

Fretwood is usually sold at so much per square foot and is obtainable in various widths.

A square foot, of course, is 144 square inches made up of the length multiplied by the width.

Thus the simple size of 12ins. square (12ins. multiplied by 12ins.) is a square foot. But then so are several other dimensions and at Fig. 1 we give the comparative areas and sizes which all go to make a square foot.

It is therefore useless to order just "a square foot" of wood. You may get a piece 24ins. by 6ins., whereas you wanted one 12ins. by 12ins. In ordering, therefore, state your dimensions of both length and breadth.

If, too, you keep a store of wood by you remember to keep it flat and in a dry place. Do not lean it against the wall where it may warp or curl. Stack it in piles and put narrow strips between each board.

Or lay all boards flat together and keep them flat by means of a weight or cramping them together, or, better still, use the Hobbies Cramp as illustrated at Fig. 2.

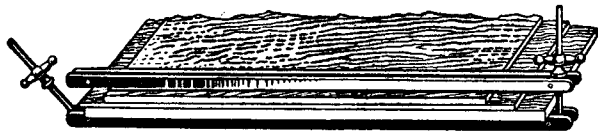

Fig. 2.—A Hobbies Warped Wood Preventer Cramp.

Plywood

Plywood is obtainable in almost any thickness from 1mm. (just under 1/16in.) to 1in. thick, being made up of several layers all glued strongly together. These layers vary from three upwards.

Plywood has the disadvantage of an unsightly edge, and can never, for this reason, supersede fretwood. It has the advantage, however, of being obtainable in large panels—and is useful for backing in cabinets, bottoms to drawers, or backboards for doors.

Inferior Layers

Moreover, very often, whilst the outer boards look good and solid, the interior layers are often of very inferior stuff, badly glued, and full of shakes. In consequence when parts are cut out for fretwork these inside layers fall to pieces and make an unsightly and often useless piece of work.

Thus, if you must use plywood get as good a quality as you can. That sold by Hobbies is specially selected as being suitable for fretwork and can be relied upon to be well layered throughout.

Patterns are generally produced on large sheets and are given away with Hobbies Weekly. They are, of course, also obtainable separately, if required. Over 500 of them are illustrated in the Hobbies Handbook covering an amazing variety of things to make.

Saving Time

Most patterns are printed full size on the sheet, and so are ready to paste down to the wood. They are cut from the sheet with scissors, running fairly close to the pattern, to save a lot of waste paper being pasted to the wood.

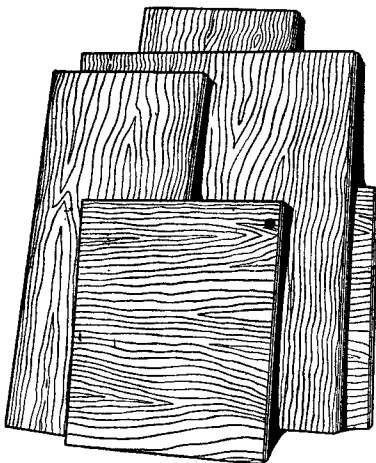

Plywood is obtainable in large panels.

In some cases, of course, the patterns are plain rectangles, and in such case there is no need to paste them down at all.

Put the paper on the wood, and fix it temporarily with drawing pins. Then take a strong pin or sharp awl or pricker and carefully make a hole through the exact corner of the pattern into the wood. Take the paper away again and connect up the pin holes made, with a sharp pointed pencil. This method saves the trouble of pasting the paper down, and afterwards glasspapering it off.

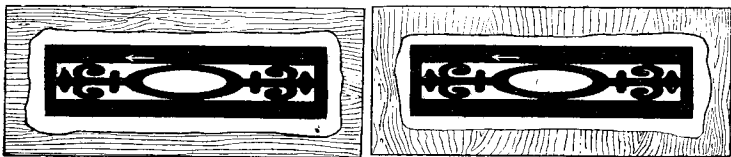

A Fig. 3.—Paste the design with the grain giving the greatest strength. **B**

Another means of saving time and cutting in the case of plain square pieces, is to mark off, or paste the pattern down so the straight edge comes along the straight edge of the wood. Get the lines true, and you save yourself the cutting of that particular portion.

Notice that every pattern has upon it a little arrow. This is to indicate the direction of the grain of wood and is an important point to remember. A glance at Fig. 3 shows the difference it makes in the strength of the finished part.

The long design pattern should have the grain running along at its greatest

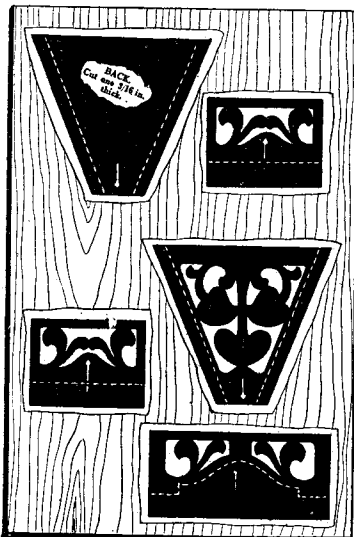

Fig. 4.—Wasted room in pasting the designs on the wood.

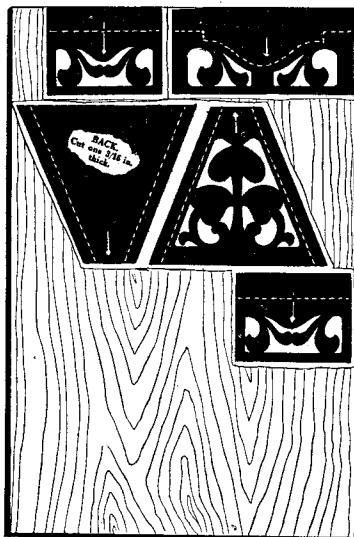

Fig. 5.—A definite saving by economical arrangement.

length as at A. At B, the pattern has been pasted down across the grain, and it will be realized how much weaker the part is and how much more liable it will be to snap, when cut out.

These two illustrations, by the way, also show how *not* to paste down a pattern. They are put right in the middle of a good piece of wood, so that a great deal of it will be wasted.

Look at Fig. 4. Here you have the parts of a sheet pasted haphazard to a board. Notice the difference in Fig. 5 where you have the same pieces arranged much more closely and providing a respectable piece of wood left over for some other job.

Duplicating Designs

If you are desirous of keeping your designs, there are two methods of doing so and yet using them. One is by tracing paper, and the other is by use of carbon duplicating paper.

Tracing paper is, of course, transparent, and almost any clean grease-proof paper will do. It is laid over the pattern to be traced, and the two held to a board with drawing pins. Then go over every line carefully with a sharp pencil, keeping accurately to the pattern. Next, take off the tracing paper, turn it over, and go over the lines again on the reverse side with a soft black pencil.

Then turn it back to its original side, pin it to the board to be cut and finally go over the lines with a hard pencil. This will transfer the pattern direct to the wood, and when the paper has been taken away, any little blemishes or omissions can be filled in.

Of course, the pattern can be pasted down to the wood when first traced off, but as tracing paper is apt to stretch and curl badly, one must take great care in doing this work.

The other method of duplicating by carbon paper is much more straight-

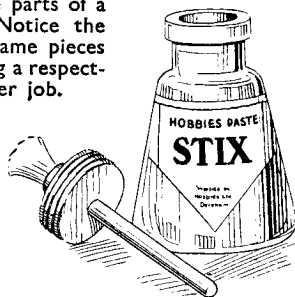

A suitable strong paste.

forward. Large sheets of suitable carbon can be obtained from Hobbies Ltd. for 3d. and this is laid on the board actually to be cut. The pattern

or design is then laid in position over it, and the two held firm with drawing pins.

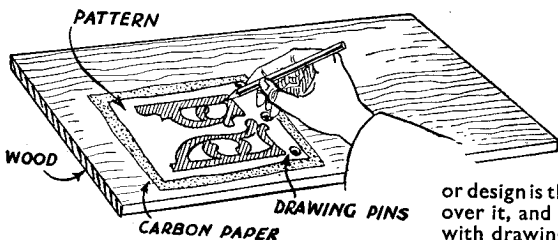

Fig. 6.—A method of duplicating a design pattern.

Now go over the pattern lines with a hard pencil or sharp pointed piece of wood and the outline will appear on the board exactly as drawn.

One must, of course, be careful to keep a continuous line with a steady hand. The lines cannot be sketched in lightly. One strong line is essential

by keeping an even pressure on the paper. At the same time, do not press too hard or the paper will get torn and the pattern spoiled.

The drawing at Fig. 6 shows the layers of paper on the wood and the method of drawing over the pattern lines.

Lots of workers put their paste on to the paper, but this is one of the principal causes of stretching. Far better to apply the paste to the *wood*, so keeping the paper dry until it is actually in position. Get the paste spread evenly and not too thickly.

Apply Paste to the Wood

Have a clean soft brush for pasting down and a clean duster in readiness. When the pattern is on the wood, pat the duster on the middle piece first and gradually work towards the outer edges. In this way the pattern goes down flat without any wrinkles or air bubbles.

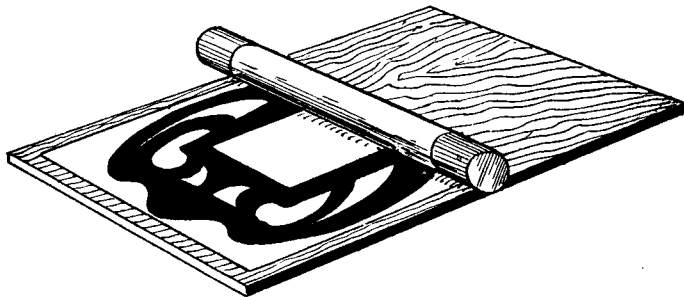

Fig. 7.—How to roll off a large pattern sheet.

In the case of large patterns, it is a good plan to *roll* them out on to the wood to ensure their keeping flat. For this, a round ruler or a length of clean smooth broom handle will do. The paper is turned round this stick and then rolled off on to the pasted wood, as shown in the picture herewith at Fig. 7.

CUTTING OUT THE WORK

THE beginner will be well advised to attempt small things at first and to have patience. He cannot expect to be an expert immediately and must learn to overcome the elementary troubles gradually.

The usual trouble is for the beginner to attempt to *force* his saw right through the work and so place too much tension on the tiny blade that it, naturally, snaps.

Another thing, the sawblade is usually put in the frame too loosely. It must be quite taut to cut well and worked up and down with sufficient pressure to cut gently and evenly along the required line.

Some Simple Lines

A good plan is to set yourself some exercises in odd pieces of wood. Get a board and mark on it lines similar to those shown at Fig. 1.

Hold the wood firmly down to the cutting table with the left hand (see Fig. 2) and use the handframe in the right. Keep an even stroke of the saw up and down steadily. Not too fast and not too slow, and do not have jerky strokes.

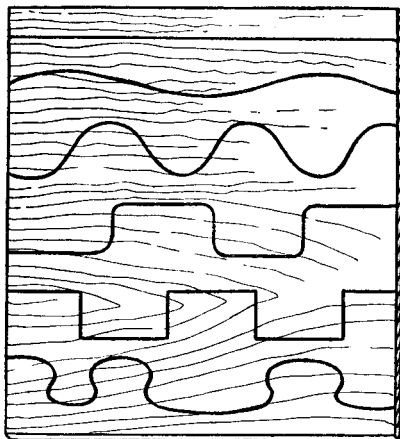

Fig. 1.—Simple cutting exercises.

Hold it Down

The wood is apt, at first, to spring off the table and one feels afraid of the blade running into the fingers. That will soon be overcome and the wood can be controlled and turned at will by a movement of the left hand.

Keep the saw well in the V opening of the table and hold the work down so it does not slide about.

Having mastered the exercises of Fig. 1, pass to something more difficult and endeavour to undertake those illustrated in Figs. 2 and 3.

Here we have two definite styles which mark a big advance in our cutting. On one board are marked a more 'wavy' set of curves and then of curves which form acute angles. On the other board the same principal is dealt with but having straight lines and acute angles.

Simple Exercises

Finally at Fig. 4, we have an exercise in repeating a single design, the cutting of which, will prove our mastery of the saw.

Now for a few points to watch when you first begin cutting, and which will become natural when you get used to them.

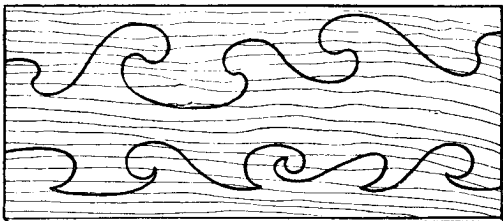

Fig. 2.—Some more advanced curves to mark and cut out

Fig. 3 (right)—Straight lines with corners and sharp angles.

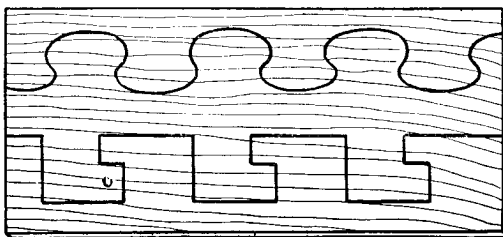
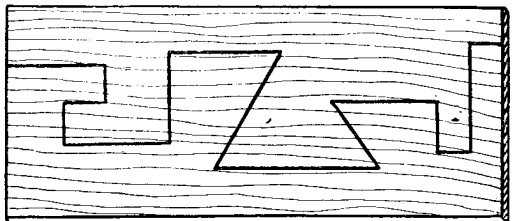

Fig. 4.—Practise on repeating a similar pattern shape.

The foremost is that of holding your saw upright. Be sure to keep the handframe itself in line with the arm so the saw blade is vertical. This is most important and absolutely essential for accurate cutting.

Vertical Cutting

Let us imagine for a minute we have a thick piece of wood to cut. If you let the handframe sag at the back, then obviously, the saw will cut deeper in the lower portion of the wood than it will at the top. This may not be noticeable in thin wood, but the trouble is still there, and should be avoided.

Imagine a thick piece of wood again with the saw cutting on the slant. The underside will contain a very different pattern from the top. The exaggerated section at Fig. 5 illustrates it quite clearly where the cutting is wrong and where the saw is being held upright.

A glance at Fig. 6 shows the result of such cutting. The pattern has been completed with the saw on the line at the top of the wood. But it has been held on the slope most of the time, and in consequence, when the wood is turned over, as in the second picture, we have a very different design.

The curves here have become thickened up, the linking pieces ugly and unnecessarily large.

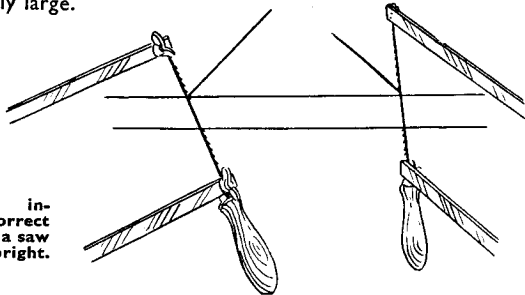

Fig. 5.—The incorrect and correct way to hold a saw for cutting upright.

Learn too, to take a saw up to a point and then stop. See you do not go beyond the end of the line, or stop short of it. This can only be done by practice, but it is as essential as the other exercises mentioned earlier.

And a final point for this chapter is on the question of turning.

If you cut along a line, stop, and then turn your wood, you will wring the tiny blade and in all probability break it.

The only way the saw *can* be turned is when it is moving up and down.

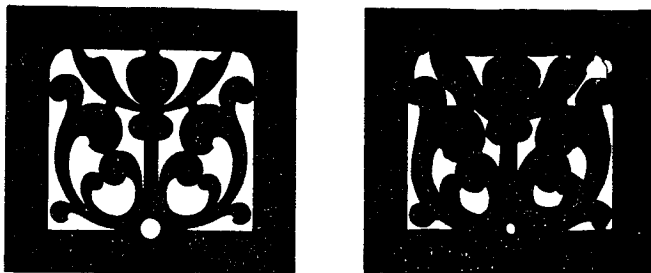

Fig. 6.—The design on the left would look like the one on the right if cut with a sloping blade.

The beginner is always apt to turn his saw or his wood too quickly. He must keep his saw moving steadily up and down without actually moving forward.

Take a right angle corner as shown at Fig. 10. The natural tendency is to sweep round as quickly as he can with the saw still moving up and down. The result may be any of the errors shown where a curved line is produced instead of a true angle.

When he gets to the actual turning point he must hold the wood from going any further. The handframe must continue to be worked up and down, but the saw must not be cutting forward. Gradually the wood is turned in the required direction, so the sawblade is actually making room for itself to turn in order to face the new line to be cut. It is turning in a very tiny hole, and when the teeth are quite round, and not before, the frame can be gradually pressed forward along the second line of the angle.



Fig. 7.—The position of drill holes.

fingers of the other operated the loose bobbin. When the bobbin was ran up and down the shank, the bit revolved at a high rate, boring its way through the wood to make a clean hole just large enough for the sawblade.

It is a mistake to try and drive the bit through too quickly. Keep a light pressure on the top of the drill, running the bobbin up and down quickly. Do not *force* the bit through, or it may snap.

Turn and Pull

Remember, too, when you extract the bit to rotate also. If you try and wrench the bit out of the board—this is likely to snap off. There should be no need for this to happen if the board is held to the table firmly with one hand and the other used to turn off the drill, lifting it gradually at the same time.

Every fret which has to be cut out, naturally needs a hole to be bored to allow the blade to enter. Some frets need more than one drill hole, because the saw can then be turned quickly without moving it up and down.

The position of the drill hole, too, can often save much unnecessary cutting, and as one gains experience the placing of these drill holes becomes apparent.

Let us now look at a few, by means of a simple pattern as illustrated (Fig. 7). Here it will be seen that the hole is made at the widest point of most angles, and the explanation of this can be seen by the diagram at Fig. 8.

Obviously, the blade cannot be turned in the acute angle at the bottom. Make the drill hole at the point shown, midway between the two lines. Insert the blade and refix in the frame. Commence cutting by going across to the point at A, gradually working to the line of the pattern and so going down to the end at B.

The Need for Drill Holes

No two designs are alike in reality, but all are alike in general. There are interior curves, angles, straight lines and joints to be cut and the saw has to get into these frets without cutting the surround.

For this we need the archimedean drill with its tiny bit—a tool which has been described in an earlier chapter. As was shown there it was held upright by the palm of one hand whilst the

bobbin was ran up and down the shank, the bit revolved at a high rate, boring its way through the wood to make a clean hole just large enough for the sawblade.

It is a mistake to try and drive the bit through too quickly. Keep a light pressure on the top of the drill, running the bobbin up and down quickly. Do not *force* the bit through, or it may snap.

Remember, too, when you extract the bit to rotate also. If you try and wrench the bit out of the board—this is likely to snap off. There should be no need for this to happen if the board is held to the table firmly with one hand and the other used to turn off the drill, lifting it gradually at the same time.

Every fret which has to be cut out, naturally needs a hole to be bored to allow the blade to enter. Some frets need more than one drill hole, because the saw can then be turned quickly without moving it up and down.

The position of the drill hole, too, can often save much unnecessary cutting, and as one gains experience the placing of these drill holes becomes apparent.

Let us now look at a few, by means of a simple pattern as illustrated (Fig. 7). Here it will be seen that the hole is made at the widest point of most angles, and the explanation of this can be seen by the diagram at Fig. 8.

Obviously, the blade cannot be turned in the acute angle at the bottom. Make the drill hole at the point shown, midway between the two lines. Insert the blade and refix in the frame. Commence cutting by going across to the point at A, gradually working to the line of the pattern and so going down to the end at B.

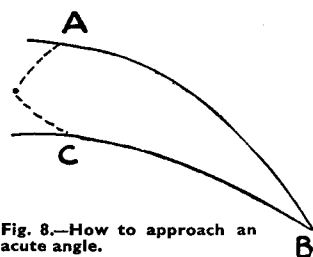

Fig. 8.—How to approach an acute angle.

You now have to turn back the blade carefully—still with an up and down movement—up to the drill hole. Turn the wood so the teeth face the other way and commence to cut across to C. From there the saw goes down to the line until it arrives at B again.

In the case of projecting angles, however, another method is used as illustrated (Fig. 9). Here the black portion is the wood and the other the waste. The saw goes along in the direction of the arrows, and instead of turning sharp at the point, it continues in a small circle (shown by the dotted lines) approaching the angle again to make a nice sharp point.

Finally (Fig. 10) we see how drill holes are made when straight lines and angles have to be negotiated. The drill hole is made near the cutting line and

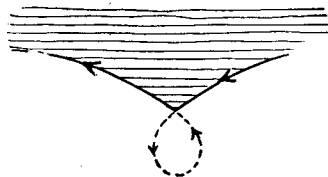

Fig. 9.—The saw is turned in the waste wood for projecting curves.

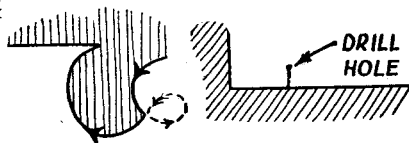

Fig. 10.—Hole for a right-angle corner cut.

the sawblade taken up to it before turning in the direction required. Get the saw to turn as quickly as possible when on the line and do not approach it in a sweeping curve such as shown (Fig. 8). Here the saw has cut from A to B and sooner or later must go back along B to C.

In travelling that way, it will come against the gradual angle of wood at the point marked D and it will not be easy to make the line BC a smooth and continuous straight one. If the saw however had turned on the cutting line with a sharp angle, such as seen (Fig. 11) the next approach to that part has a definite corner in which it can bite straightaway.

Now we can turn to another point in cutting—that of the ties holding the pattern together. Three examples are given in Fig. 12—each one of which will be met with during the usual work.

On the Line

In the case of A you have a little globule linking piece which actually throws the design away from the framework. The particular pattern is the most awkward because the saw has to approach the globule or head portion four times to cut down to the acute angles shown.

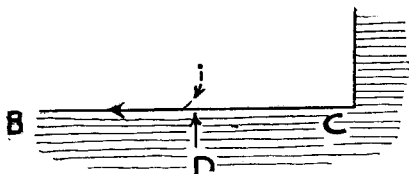
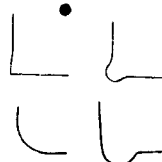

Fig. 11.—The wrong approach to a straight line.



A good corner and some bad examples.

At B you have links formed by the pattern just touching the other parts and this forms a much easier form of cutting. Here the sawblade cuts down two sides of the angle until it meets at the bottom.



Fig. 12.—Three examples of common pattern ties used in designs.



Fig. 13.—The same patterns with linking pieces badly cut.

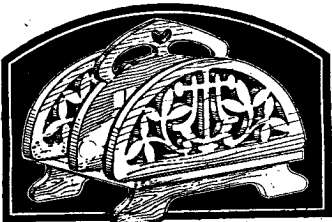

Fig. 14.—A striking pattern.



Fig. 15.—Be careful with curves

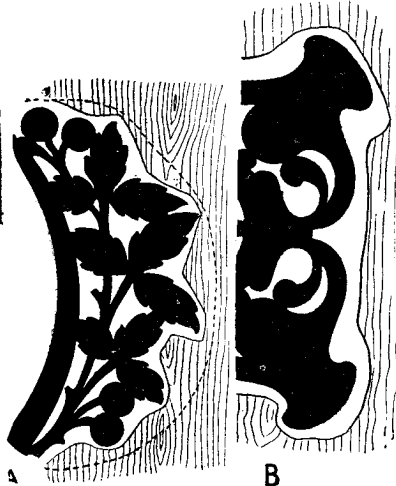

Fig. 16.—Notice the difference in the outer edges of these patterns.

The illustrations at Fig. 13 show clearly the result of not getting a proper cut to preserve the continuity of the design. The same three patterns as in Fig. 12 are shown and it can be imagined how irregular the whole design will be if completed in this style.

Now let us turn to the straight line design shown at C in Fig. 12. Here the wood or pattern is held together by linking pieces which cross each other or project from each other at right angles. This makes the cutting easier for the angles can in most cases be approached from both directions to meet in the corner.

Watch Patterns

Once again it is important to watch the design, for the lines all run to each other or through each other, as the case may be. Notice in Fig. 13 how ugly the pattern looks if these lines are not continuous—how they break up what should be a geometrical pattern.

Remember too, that all curves and lines flow from a common source or continue themselves through the whole pattern. See these lines are cut in one sweep even though intersecting pieces break through or come against it. The point can clearly be seen at Fig. 14, where we have a striking design which would be absolutely spoiled if the long stems were not gracefully interlocked and appeared jerky and irregular.

Another point to watch in some designs, is the projecting portions which have no linking pieces to support them, as in Fig. 15. Here we have a pattern which, when cut, is found to be a little weak where the grain runs across the narrow neck.

In such cases, the wood must be held well on the table so the sawblade is cutting close up to the point of the V opening. Keep the wood there firmly so the projecting piece in question rests on both sides of the cutting table whilst the saw works in the aperture.



Fig. 17.—A design with figure work features.

Projecting Pieces

Up to 3/16in. thick, the work is apt to snap if too much pressure is put on it and for that reason, where there are a lot of delicate frets, they should be left until last.

Take the two designs shown at Fig. 16. Both are to be cut in 1/4in. wood. At A you have an edge with a number of projections which must necessarily be a little weak, whilst at B you have a sweeping line.

If you cut the outline of A before doing the interior work you will obviously have a number of weak pieces very apt to break off or get caught in the continuous turning of the wood.

At the same time it is best to cut away as much waste wood round the outer edge in order to reduce the size and weight of board during the cutting work.

A good plan, therefore, is to go round near the outer edge—as indicated by the dotted line, so cutting away a lot of waste wood, but yet leaving the delicate tracery of the edge until last.

At B, on the other hand, you have a more or less straightforward edge which can be cut first, without any likelihood of pieces getting broken off during the subsequent cutting operation.

In some designs, too, there are some wide open frets to be cut, and some small ones. This is particularly the case in patterns which feature animals or figures or representations of buildings where sky or background has to be indicated.

Obviously, a special feature will not stand out if it is entirely surrounded by intricate patterns. An example is given at Fig. 17.

In cases such as these the smaller frets should be cut first, following up with the larger ones and leaving the very largest until last. In the design in question, for instance, details round the mill, the trees, and the lines of the figure would be cut first. Then one could pass on to the parts around the ducks and figure, leaving the opening of the sky—the large part in front of the girl—until last.

The reason for this, is that if large parts are cut away first, the board is considerably weakened, and more likely to snap during the constant turning necessary in cutting the small frets.

CONSTRUCTION DETAILS

HAVING dealt with the question of cutting out the parts of fretwork designs, we can turn our attention to the methods of construction. Needless to say, this requires as much care as any part of the work because it is useless taking a lot of pains in the cutting and then spoiling it by loose and careless construction.

Construction is brought about by several methods, each of which has its place and its reason. First of all, study several designs and note the joints used, and work out for yourself why they should be incorporated in preference to any others.

There are five main methods of joining the parts—the butt, halving, dowel, mortise and tenon and dovetail joints.

The Butt Joint

First of all the butt joint, a specimen of which is given at Fig. 1. As can be seen, it consists of two pieces of wood stood against each other with a plain, straight, or butt joint.

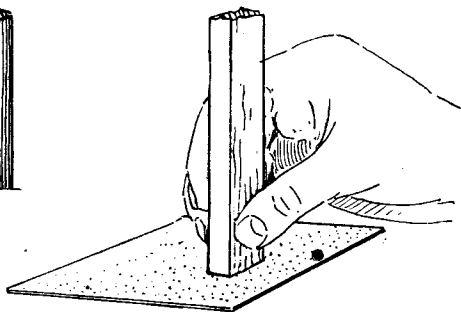
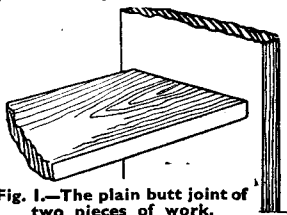

It is obvious here that the edge of one piece must be dead or straight, it will not “bed” down to the flat surface of the other evenly.

The straight line of the edge can be cut by anyone experienced with the fretsaw, but at first it is a little difficult. If the beginner finds his edge is wavy, he must get it flat on the bench as shown at Fig. 2. Hold the paper down with drawing pins and be sure to keep the wood upright.

Of course, another method of obtaining flat edges, is to run a small

plane along it until an even shaving is run off. This, however, requires a certain amount of skill in order to keep the plane level and true on the comparatively thin wood used in fretwork.

Strengthen with Screws

Obviously, this class of joint is not too good in thin wood, and wherever possible further strength should be given by adding a few screws through the back.

Now let us turn to the halving joint illustrated at Fig. 3. Here we have a long open joint cut half way in each piece in the opposite directions as at A. To put them together, the pieces must slide into each other to make a rigid joint.

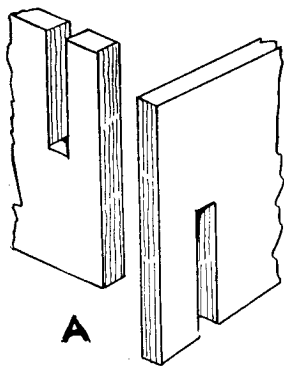

Fig. 3.—The halving joint.

The width of the slots cut, of course, is always the same as the thickness of the wood, and this point should be tested out on any design pattern before the parts are cut. Check off your thickness of wood and then use the compasses to note the corresponding halving slot is of the same dimension.

In most cases where this joint is used, the grain of the wood runs the same direction as the slot to be cut. This gives strength to the parts because it will be readily realized that the narrow portions would be weak if the grain of the wood ran across them.

These halving joints are often used in tall upright vases, where the central member consists of two main pieces. This

involves the cutting of a very long slot and there is sometimes a tendency for the part to gape. An example is given at Fig. 4, where the narrow neck of wood is apt to open at the joint if additional strength is not given.

Before finally gluing them together, therefore, bore a hole in the edge to take a long screw and drive this carefully through from one side nearly to the other. In this you close the gap and make a secure joint as well.

A very common form of joint is the mortise and tenon — illustrated at Fig. 5. Here we have one piece with a little projecting tongue (A) which fits into the corresponding slot (B). The projecting piece is the tenon and the opening the mortise.

The making of a good mortise and tenon, is unfortunately, not often found among beginners, and in competitions it is often a noticeable fault which immediately robs the entry of many valuable points.

One common failing is found, and should be overcome as soon as possible

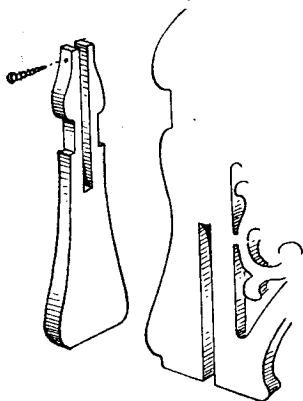

Fig. 4.—How to strengthen a long slot joint.

by the beginner. Having cut his two pieces, he finds they will not go together. The tenon is laid on the bench and an endeavour made to thin it down by means of glasspaper. But, unfortunately, the paper is not kept perfectly flat on the wood, and the outer edge of the board becomes thinner than the back edge.

In consequence, when the tenon is put in position, it fits lightly at one edge and is loose at the other, making a joint that will wobble about badly.

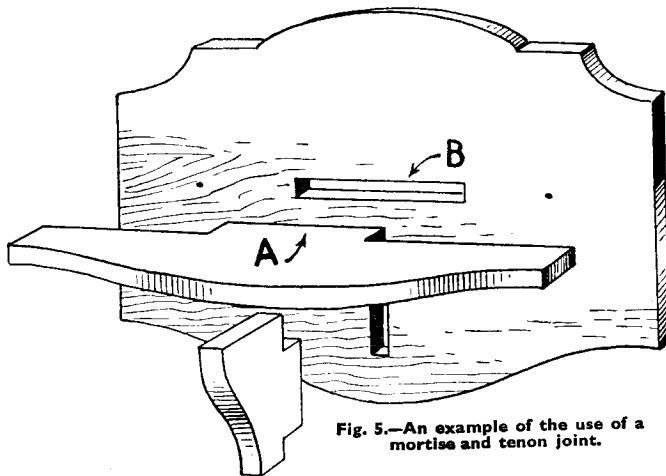

Fig. 5.—An example of the use of a mortise and tenon joint.

The way to overcome it, of course, is to use the glasspaper on a block or piece of wood to ensure the complete surface of the tenon is papered down evenly.

A Good Joint

The dowel joint previously mentioned is used principally in thicker wood because it consists of short pieces of round rod let into the actual thickness of the material. As these dowels are usually $\frac{3}{16}$ in. in diameter, it follows that the wood must be $\frac{3}{8}$ in. thick at the least to accommodate them. Thicker material is even better because it gives a better joint.

The mode of use is illustrated at Fig. 6, where the actual dowels can be seen projecting from one piece ready to sink into the holes in the companion piece.

This form of joint is usually employed where a piece of end grain has to be joined on because glue alone is not strong enough to get a good grip if a plain butt joint is employed. The dowel is sunk and glued into both pieces and makes a solid and rigid joint.

Obviously, if the holes are not bored opposite each other, the wood will not come together true.

Or if the hole is bored at an angle instead of straight, then the dowel will get wrung in being forced home and will, in all probability, break off at the crucial moment.

There is a proper procedure in both cases to overcome these troubles, and it is much better to pay attention to these points and take a little time

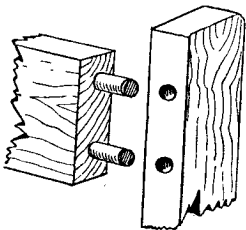

Fig. 6.—The dowel joint.

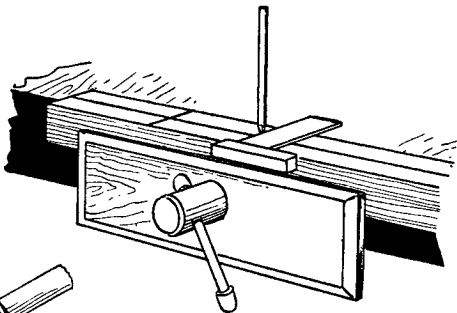

Fig. 7.—Marking the wood to make an accurate joint.

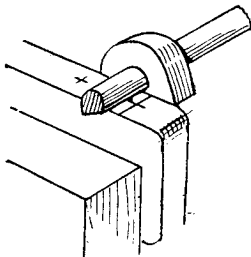

Fig. 8.—The use of the marking gauge.

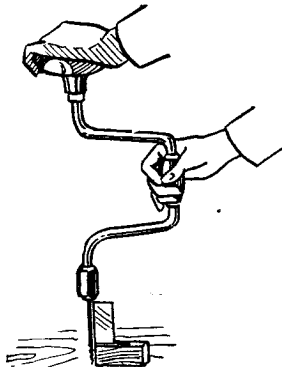

Fig. 9.—Use a square when drilling

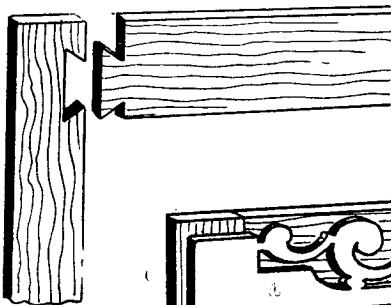

Fig. 10.—A dovetail joint is used in certain work.

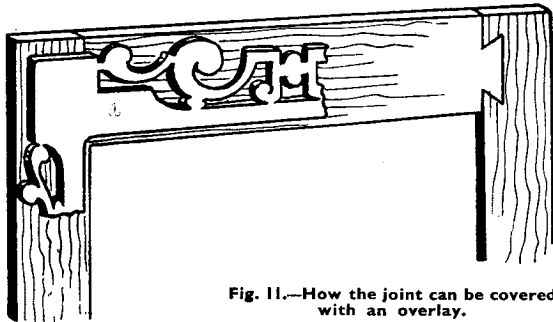

Fig. 11.—How the joint can be covered with an overlay.

over them, rather than rush the work and have to do it again because of bad craftsmanship.

It is essential in the first place, to mark out the two pieces of wood together, and Fig. 7 shows it being done. The work is cramped up in a vice and the position of the dowels measured off. Then, with square and pencil, a line is drawn across both parts together.

Thus we have one position shown. Now, the dowel must cut in the centre of the thickness and this position must be marked off also.

Suppose you have $\frac{1}{2}$ in. wood and your dowel is $\frac{1}{4}$ in. in diameter. When put in properly you will have $\frac{1}{8}$ in. of wood on each side. But if the dowel is not in the centre, then you will have, perhaps, $\frac{3}{16}$ in. one side and only $\frac{1}{16}$ in. the other. Obviously, you are going to have a joint that is not carrying its full strength. To get this centre point along the lines marked (Fig. 7) we must use a marking gauge, as shown in Fig. 8.

If you can, put a small square on to the wood as shown in Fig. 9 and drill steadily down into the wood.

The Dowel

The dowel itself, is a short strip of round rod, usually about 1 in. long. A fairly thick wooden skewer can sometimes be used, but it is much better to use the properly prepared dowel rod sold by Hobbies Ltd. It costs only about 1d. for 3ft., and has the advantages of being quite round and of suitable texture.

Obviously, if the dowel has to be hammered home the air beneath it cannot get out, and the glue at the bottom of the hole cannot squeeze through. It is desirable, therefore, to cut a little V groove down the length of the dowel to allow the air and glue to escape.

The end of the dowel is also usually slightly rounded to bed home better.

Glue in Place

When the parts are ready to be finally fitted together, brush some glue along the edge of the two pieces of wood, then dip the dowel into some glue and drip it right home into the hole. Coat the other end of the dowel also with glue, and put on the second piece of wood. Mallet them tightly together (taking care not to bruise the work) and then, if possible, cramp them together until the glue has set.

The Dovetail Joint

The remaining joint mentioned is the dovetail, and this is much more frequently used in ordinary carpentry than in fretwork.

The method is shown at Fig. 10, where it can be seen how the parts fit together so they cannot be pulled apart again by any direct strain.

There is one drawback to this particular type so far as ordinary work is concerned, and that is the ugly look of it. To overcome this, the dovetail is only used in fretwork where it can be covered by an overlay, and an excellent example is given at Fig. 11.

Here the framework has been put together by means of the dovetail joint, and one end is completely covered by the shapely overlay.

The cutting of the joint, of course, is done with the fretsaw. The projecting piece should be cut first, taking care to get straight edges and shaped angles.

Then the part cut is laid in position on the other piece of wood, and the actual outline marked round with a pencil on to the actual material. Get the pencil point close to the cut edge and line it in stronger afterwards with a ruler. When cutting, keep the saw on the line marked, and then test out the two pieces for a good joint.

Shaped Edges to Wood

It often happens in fretwork that the edge of the wood is not left square but is shaped off. This is sometimes done round mirrors to prevent the glass having a deeply recessed appearance, and in this case the edging is usually shaped to a chamfer as in Fig. 12.

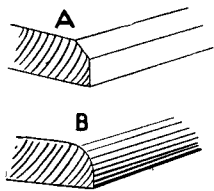

Fig. 12.—Shaped edges to wood.

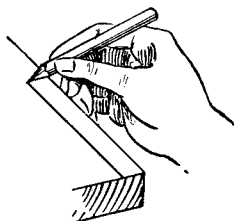

Fig. 13.—How to mark off the edging.

The other popular shaping is to have the edge rounded as in detail B, and this is usually done to lessen the apparent thickness of the wood. It is seen in tops to tables, in base boards, and in parts where two or three boards are built up for a foundation.

Let us take the chamfered edge first. The great point is to get an even

straight line of cutting the whole way along the edge, and for this it is essential to make a pencil mark on both sides which have to be cut.

Marking a Line

Take the pencil between the finger and thumb so the nail of the second finger holds the pencil point the correct distance on the wood (see Fig. 13).

Then by drawing it along the edge, a straight even line is made the whole length. If, however, you cannot get it true, measure the distance inwards at each end and connect the two points up with a ruler and pencil.

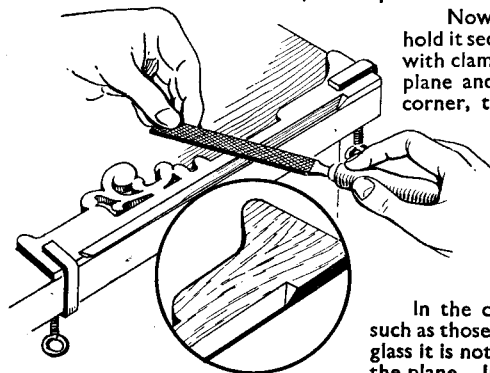

Fig. 14

Now put the wood in a vice or hold it securely to the bench or table with clamps. Get a small fretwork plane and run it along the sharp corner, taking an even shaving off the whole length.

Be sure to hold the plane at the correct angle, gradually taking off a wider and wider shaving until it's cutting along the two pencil marks on both edges.

In the case of interior chamfers such as those round a mirror or piece of glass it is not possible, of course, to use the plane. In this case we must have a straight flat file about $\frac{3}{4}$ in. or 1 in. wide

of medium grade and long enough to hold in both hands.

The file must be used across the wood in a sloping drag, even pressure being made across and along at the same time in the manner shown in Fig. 14.

In small work the wood can be laid on the cutting table so the file works through the V opening. In the case of a circular opening having to be chamfered, a half round file, of course, must be used.

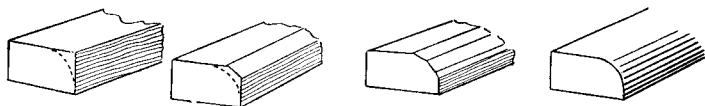

Fig. 15.—The stages of shaping a square edge to a round one.

Now let us look at the round edge as at B Fig. 12. If the wood is thin, it is a simple matter to use a medium grade glasspaper and finish up with a fine grade glasspaper to get a perfectly smooth finish.

Hold the paper in the palm of the hand and rub it along the edge to be rounded, taking great care to get the curve even both sides. As before, it is advisable to mark a line to which the curve will extend in order the paper may not carry it too far.

If the wood is thick, say $\frac{3}{8}$ in. or more, it is advisable to take off the first portions with a small plane. Having marked the work out, plane along to take the corner off. Then take the angles off by gradual turning, following out the stages shown in Fig. 15. The dotted line on the end shows where the curve is to come, and the final operation is with the glasspaper as before.

Special Nails and Screws

The nails and screws used in fretwork are naturally not so "hefty" as those in carpentry and have long thin shanks to take the thinner material. A range is shown at Fig. 16, and those supplied by Hobbies Ltd., vary from $\frac{1}{8}$ in. to $\frac{3}{4}$ in. Naturally, such thin nails are more delicate than the usual kind, and in consequence a lighter hammer must be used.

Do not get the ordinary household hammer and expect the nail to go in

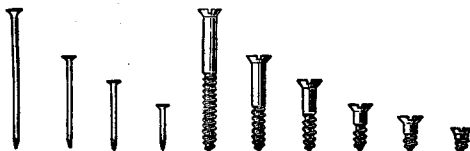

Fig. 16.—Long thin fretwork nails and screws.

at one heavy blow. All that happens is that the nail crumples up and probably makes a nasty mark on the wood. It should be stood in a hole bored to start it off and then tapped home carefully by a succession of light knocks.

When Awkwardly Placed

If it so happens that the nail is in an awkward position so you cannot hold it with your fingers, a good plan is illustrated at Fig. 17.

Get a strip of fairly stiff paper or thin card—a postcard will do—and push the nail through at one end. Put the nail in position and hold it there by means of the card, knocking it in a little way until it stands by itself. Then tear away the paper or card and drive the nail right home.

In many cases a fret nail can be used and the head nipped off so it does not show. This applies particularly with moulding and fancy beading.

Overlays are really decorations added to relieve the plainness of the work. They are sometimes also used to hold glass or mirrors in position, but the decoration is their main function.

In consequence, they must be light and dainty and never cut in thick

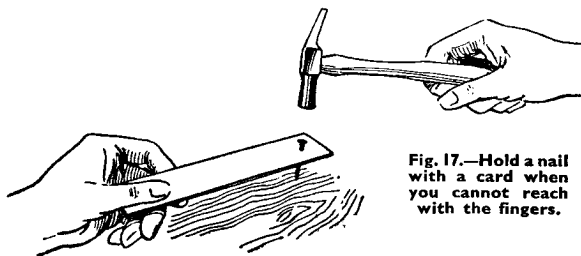

Fig. 17.—Hold a nail with a card when you cannot reach with the fingers.

wood which looks clumsy and unsightly. The usual thickness is $1/16$ in. or $1/8$ in. and should very seldom be more.

If $1/8$ in. wood is being used, the pattern is pasted down to it in the ordinary way, and sawing commenced on the interior frets. The outer edge should be left until last to provide the greatest strength to the last moment. Notice the way of the grain, to put the overlay pattern down to get the longest way also for the greater strength.

Hold the work to the cutting table with the fingers close to the blade (see Fig. 18) to prevent the wood jumping or any of the delicate parts becoming damaged. Take care to get all points sharp and true, and maintain an upright saw all the time.

If $1/16$ in. wood is being cut it will be even more delicate and should never be sawn alone. Very often two or more overlays are required of the same shape, and in $1/16$ in. wood they can be cut together.

If, however, only one is required, then it should be fixed temporarily to another board to give greater strength. It can be nailed to a piece of $1/8$ in. wood, long fret nails being driven through both pieces and turned over on the underside.

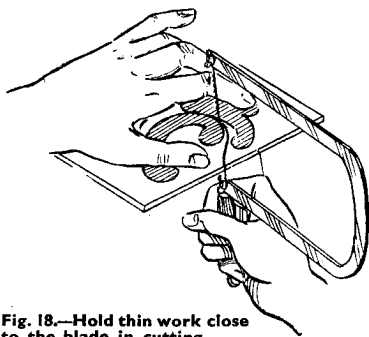

Fig. 18.—Hold thin work close to the blade in cutting.

This cleaning with glasspaper must be undertaken carefully, so as not to damage any part, and the paper must always be used on a block to keep it flat.

The framework of waste wood can be nailed down to the bench, and the overlay replaced in position as shown in Fig. 19. Thus it is held quite flat, and the edges will not be broken, as is likely to occur if the part is held loosely in the hand.

After cleaning, the overlay is ready for fixing with glue, but make sure you know the exact position before putting it in place. Lay it down first on the backboard, and mark lightly with a pencil at two or three points so it may be replaced correctly when glue has been applied.

When ready for gluing, too, have the necessary cramps or weights at hand because if not, the thin wood is apt to curl up before one can get the accessories ready.

Put a board each side of the work, and then use several of the Hobbies light steel cramps over the edge at various points to keep all together, as shown at Fig. 20. Leave the work until the glue has set.

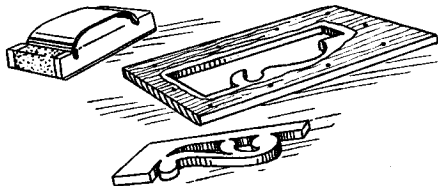

Fig. 19.—A framework for papering.

wood with a pair of sharp nippers.

Another method is to cut off a short length of fretnail or pin, and push the blunt end into the main work, leaving the points just projecting, as seen in Fig. 21. Then when the overlay is glued in place, the pins press into the part and prevent moving.

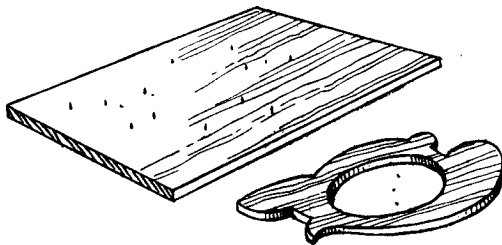

Fig. 21.—Pin points to hold the part in place.

surface. Particulars can be seen in the Hobbies Handbook.

If the overlays are large, or have a tendency to rise, a good plan is to put in two or three pins or fretnails, cutting off the heads and projecting part flush with the

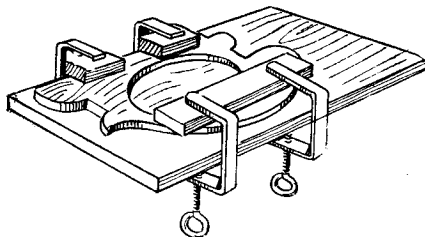

Fig. 20.—Cramp the work when gluing parts together.

Of course, overlays can also be cut in other material besides wood, and many competition or exhibition pieces are enhanced by this usual method. A popular substance is xylonite or ivorine, which are a thin composition black and white respectively. It is easily cut and has a beautifully polished

Or again, sheet metal can be used—aluminium, brass, zinc, copper or even silver being equally applicable. The metal is put between two thin pieces of wood, holes being bored to take nails which hold all in place.

The design is pasted on the top board, and the cutting undertaken with the special Hobbies metal cutting saws which have their teeth specially close together for the purpose.

It is necessary to grease the blades occasionally with oil or grease to prevent them getting overheated.

MODEL MAKING

MODELS are, of course, in a different class from ordinary fretwork and many workers use the fretsaw for this work only. At the same time, the ordinary fretworker should realise the potentialities of this work, because it sometimes affords an interesting variation from the usual routine of fretwork.

It is, indeed, a good plan to become proficient in the art of model making, because occasion may arise when a good order can be obtained from a friend or customer who is desirous of purchasing one.

There is probably no end to the number and variety of models that can be made with the fretsaw, which a glance through the pages of Hobbies Handbook reveals.

There are, in this respect, a number of methods. A stationary steam engine forms an effective and spectacular form, particularly suitable for exhibitions where one is constantly in attendance. Many models can be connected to an electric motor so they run continuously without attention and at little cost.

Or there are a number of satisfactory clockwork motors which can be put into certain models and wound up to make them perform as occasion requires.

Two Types

The two classes—stationary and working—each demand a distinct type of work, but in general cutting and construction, there are many similar points worth noting.

There is not, for instance, so much interior fretcutting to be done, but the work involved is more on the fitting and testing side. There is, too, very often a good deal more shaping to be done, where rasp, file and glass-paper are required. Aeroplanes, motor bodies, domes to buildings, and the like, must all be nicely rounded off and infinite care taken to see they are the right shape.

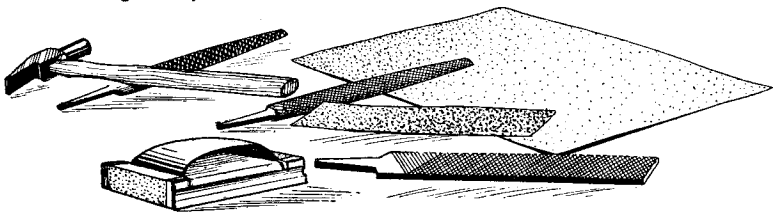

In making working models, the great point to remember is to see that all moving parts are cut, shaped and finished true. Wheels must revolve in a perfect circle, and shafting must connect on the rods to take the proper amount of movement. Any amount of time must be put into these points, and tests made again and again until perfection is attained.

When possible, parts should be cut together to ensure them being the same.

Wheels—on a motor car or locomotive—which are running in pairs must be tested in pairs, and then marked so they may be finally fitted in place together.

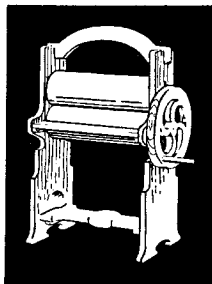
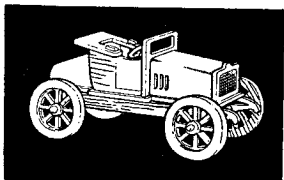
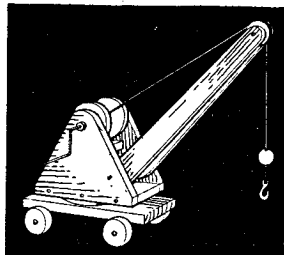

Never attempt to hurry your work, in cutting, fitting or assembly. If you find you are getting a little tired of one operation, turn over to another. Do a little cutting, then clean up some parts, and then test some out in position.

Suitable Small Models

One great point to remember is that models should be painted to make them more realistic. This also covers up the edges of plywood and of any heads of nails or screws which would otherwise be seen.

If the models are of buildings one can very often use the brick and slate or tile paper sold by Hobbies Ltd., but if painted, a drab stone colour is principally used. Follow out the actual colours of the building as nearly as possible, using a different paint for doors, windows, balconies, etc.

A rough cast stone effect can be obtained by coating the wood with warm glue, and then covering it with sawdust or very fine sand. If bricks

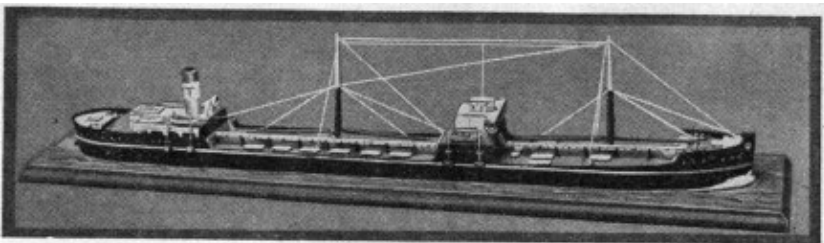

are painted, a red should be put on first and allowed to dry, and then the lines of cement drawn on in cream or buff with a pen or fine brush.

There is no need to buy the usual large tins of colour because special small tins are obtainable for 2d. each. The exact colour is shown on the lid, and a very wide range is now supplied by Hobbies Ltd.

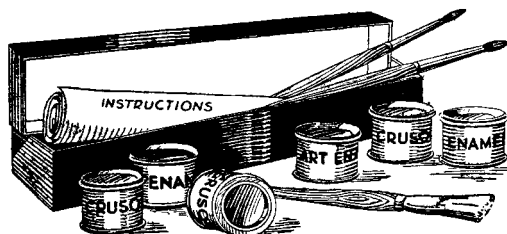

Remember, finally, to allow one colour to dry thoroughly before adding any other colour close to it. If you do not wait, the two will run together and form an uneven and unsightly line.

INLAID WORK

THERE is another class of work which is very popular with many workers and which the beginner should at least know about for it provides another use for the fretwork tools he already possesses.

The use of the various kinds and colours of fancy wood used with the fretsaw enables some very nice work to be done in inlay and a number of examples are to be seen in the current Hobbies Handbook.

There are really two kinds of inlaid work—one where two kinds of wood are used and the other where four are used.

Let us look at the former first, and as an example take the Design No. 1341 where the inlaid work has been introduced into the back of a lady's hand mirror.

Perhaps the side view of the two pieces at Fig. 1 illustrates the operation better. At A we have two pieces of $\frac{3}{16}$ in or $\frac{1}{8}$ in. wood nailed together, with the nails driven through outside the actual design and turned over underneath.

The saw in cutting out the pattern is going through the wood at a slight angle, which is purposely exaggerated in the picture. A fine blade is used and when the cut is completed two pieces fall out.

It will be found actually, that the underneath one is slightly larger than the upper one, so when is it pressed upwards into the top wood, it fits there very tightly in place as shown at B.

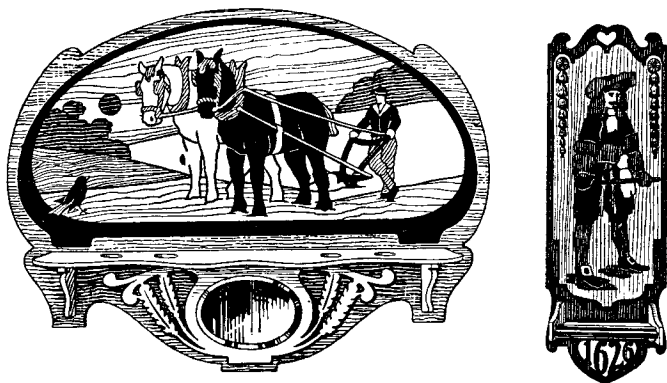

Two examples of inlay work in several kinds of wood.

This bevel cut is only obtained, of course, by having the cutting slightly depressed one side. This can be done easily on the machine, whilst the handframe worker must have a special tilting table supplied quite cheaply by Hobbies Ltd.

Two simple examples are given of the work at Fig. 2 as suggestions which can be followed or elaborated by the worker who is also a draughtsman.

The finished patterns are glued together as a single piece and can be stained or polished if desired.

Now we come to the other form of inlaid work. This is by the use of

different kinds of wood which are cut together at one operation with the vertical saw

The work does not call for any great amount of trouble and, in consequence, is more popular amongst workers in general. Proof is given in the special section devoted to it in the Handbook.

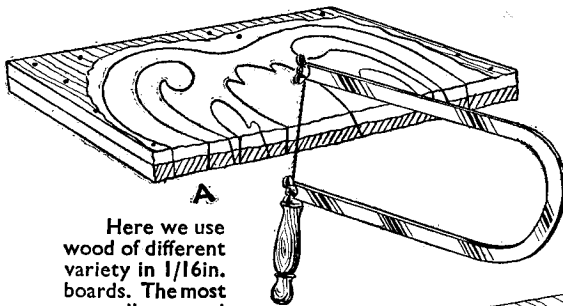

A
Here we use wood of different variety in 1/16in. boards. The most generally used are oak, padouk, mahogany, satinwood, satin walnut, beech, and whitewood. All these have a contrasting colour against the others and, in consequence, make a very vivid and attractive piece of work

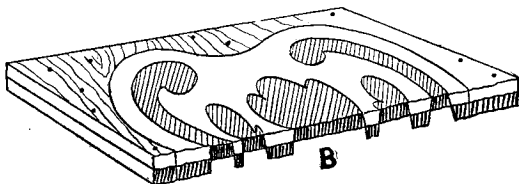

Fig. 1.—Two boards nailed and cut together at the same time.

The design is pasted to the wood, in the usual way and then all four (or three, as the case may be) are nailed together as mentioned before. A number of nails may be used providing they are outside the design. Because, it must be remembered, all parts of the design are used in the finished picture or panel.

Next, drill a tiny hole and thread the saw through. Keep the table flat and the blade vertical as in ordinary work. Start off from the hole and go round the outline of the nearest part, returning to the starting point. The operation is shown at Fig. 3 where the saw goes round the shaded piece starting and finishing at the point marked A.

Having done this, four pieces exactly the same shape fall out. Of these only one is required for the actual panel. Inlay patterns are usually drawn in outline each part being marked with a letter which tells you which piece of wood is required. Put this piece aside and discard the others.

The parts kept are put together, to form the picture or panel required.

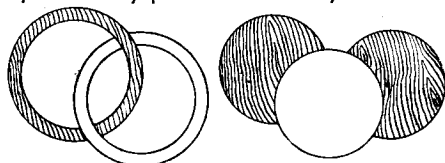

45 Fig. 2.—Simple examples to cut in two woods.

Next, go round the adjoining part with the saw, so some more pieces, all alike come out. Select the one wanted and lay it in place against the first one.

So you go on into the design, gradually cutting out the various parts and keeping one of them to build up the picture wanted.

Thus when the last piece is taken out, you only have the framework which is nailed together and which can now be thrown away. But you also have a complete panel of various woods to form the picture required.

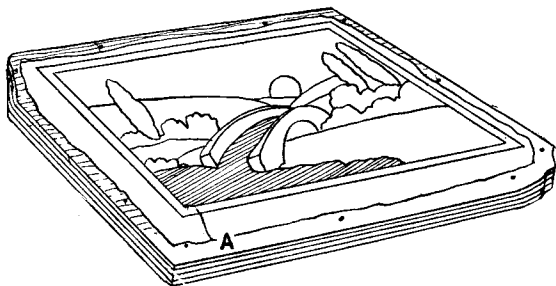

Fig. 3 (left)—Commencing work on the four boards at point A.

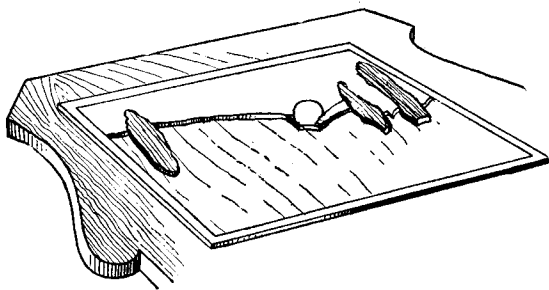

Fig. 4.—Put the pieces in place to build up the picture.

These pieces, of course, must be glued together to a backing board, and it is usual, too, to have a framework which helps to hold them in place. This frame is glued on and then the inlay parts are put in.

Spread the glue on the backing board inside the frame fairly thickly because you want it to squeeze up between them to hold the edges together. Put the parts in position (see Fig. 4) and when all are in place, lay a thin piece of paper over it and then a thick board before the whole lot are weighted down or cramped together.

When the glue has set, take away the cramps and tear off the paper, which was placed there to take any glue which oozed out on to the top. Then rub the board thoroughly down with a coarse grade of glasspaper and finish off with a fine grade until a semi-glossy and perfectly flat surface is obtained.

The picture is now complete and can be finished off in the usual way with stain and polish.

It is, of course, one of the big advantages of the inlaid work that perfectly flat surfaces are obtained, and these are easily polished. Indeed, the natural grain of the wood lends itself to a glossy surface. The inlaid panel can be finished either apart from the main work itself, or left and completed at the same time. Some, too, may prefer to get a polished surface to the work by the addition of a coat of varnish, but this should be perfectly clear so it does not discolour the natural grain of the wood in any way.

It will be realised, too, that in cutting the four woods you actually have the possibility of making up four distinct pictures from one operation. It just depends on the class of work, but it is not always possible to get four entirely suitable pictures because the particular wood for some parts may not be in keeping. For instance, a light wood is required for any sky effect and it would spoil the picture to have it in mahogany.

SUITABLE FINISHES

THE question always arises as soon as one takes up fretwork, as to the best way to finish off the work. Now that is a question of individual taste and ability, and there is the choice of several methods—all of which appeal to different people.

If work is done in nicely grained wood and left with a perfectly smooth and semi-glossy surface, there is frequently no need to apply any finish to it.

Varnish

The most popular method is to stain and polish the work, and when one has had a little experience, this produces a beautiful and highly artistic finish.

It is generally necessary to stain the work because so often different pieces of wood are of different colour. The first job, therefore, is to render them all alike with a dye of the shade required.

The amateur is fortunate nowadays in having a range of stains ready mixed for him to use. Now, thanks largely to Hobbies' stains, almost any colour can be got to match the actual wood and render it more beautiful. These colours, moreover, are obtainable for a few pence, and a full range of them is given in the Hobbies Handbook.

Two Classes

There are, first of all, two classes of dye used. One is a water stain and the other is a spirit stain.

The former is sold as a powder and is dissolved in water to the depth of colour required. The spirit stain is supplied in liquid form in bottles.

Both are applied with a brush or a rag, and soaked into the wood to colour it to the shade required.

The water stain has the slight disadvantage that the dampness raises the grain of the wood and takes a good deal longer to dry. The length of time actually, of course varies according to the temperature of the room, the time of the year and so on.

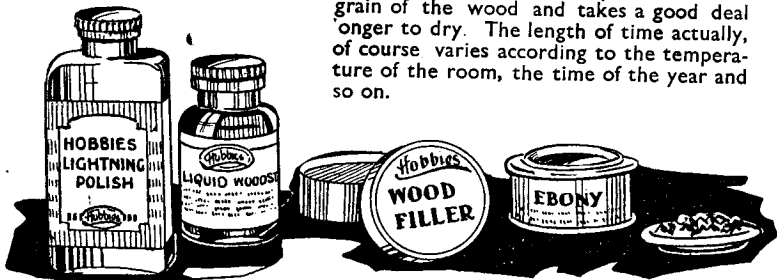

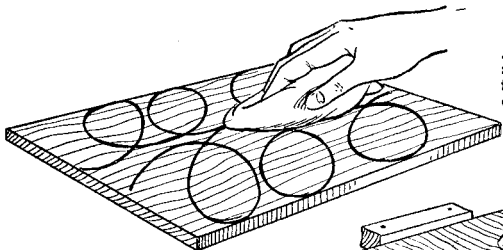

Apply the polish with a circular motion and finish by sliding off the edge.

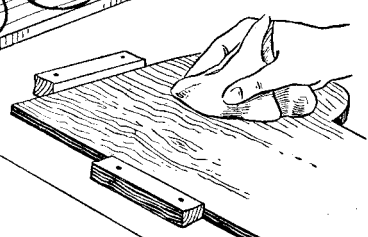

Blocks on the bench will prevent the work slipping.

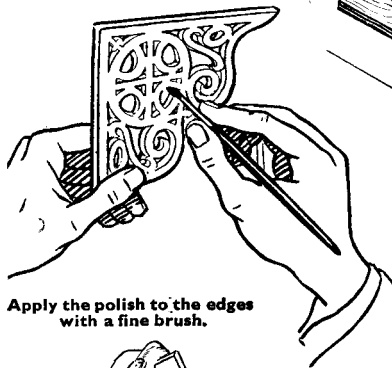

Apply the polish to the edges with a fine brush.

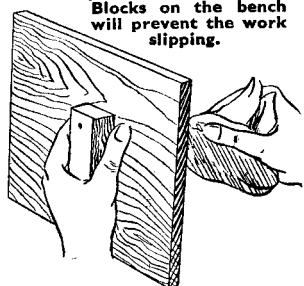

A block nailed to the back serves as a useful handle temporarily.



Stain can be swept on with a wide brush.



The shape of the rubber and how it is held.

Spirit stain, on the other hand, soaks into the wood immediately, colours it up and is dry in almost a very few minutes.

It is best first of all to try out the stain on some piece of waste wood to ensure having got the correct colour.

If water stain has been used, it will need rubbing down very lightly with a worn piece of glasspaper to take off any of the fibrous ends which may have been raised.

Use a Filler

If the wood is particularly soft it is advisable, too, to use a wood-filler before putting the stain on. This fills the grain of the wood and so prevents it absorbing so much of the liquid and later of the polish.

The question of polishing, of course, depends largely on the actual job in hand. The most suitable are naturally those with large flat surfaces in which a gloss can be obtained by rubbing on the polish with a rubber. If the parts are fretted, it is a different matter.

Some workers prefer to polish the wood first, and then cut out the frets, whilst others like to do the cutting and then polish afterwards. The difficulty, of course, with the latter process, is that the polish soaks out on to the edges of the frets, and more care must be taken to wipe them off. The actual edges themselves are treated with the polish on a brush.

Use of Wax

Another method of finishing is to leave the work semi-dull. That is, a stain is put on to colour all the wood down to the same shade, and then the surface is waxed. Floor polish or the special Waxine supplied by Hobbies is suitable, and it is rubbed on and then off in the usual way.

In the case of oak, the surface can be dulled and slightly darkened by the use of linseed oil. This is rubbed into the work on a pad, and so brings out the grain of the oak and also makes it a little more colourful.

Oak, too, of course, can be stained a Jacobean shade and left dull if desired. Fumed oak is nowadays not often used, but this requires a special fuming chamber, particulars of which will be found in the polishing handbook of Hobbies.



THE USE OF FRET MACHINES

It is, undoubtedly, the ambition of every keen worker to be the possessor of a machine, and in view of the very large number who are already possessors, a chapter on the subject would not be out of place. The fret machine, of course, has a great number of advantages over the handsaw.

First and foremost is the fact that it leaves both hands free to operate the work. The process is actually the reverse of the handframe. In the use of that, the sawblade moves through the wood. With the machine, the saw does not move forward at all, but the work is pressed up to it. The wood is held down to the table with both hands, and can naturally be turned and twisted with much more ease.

The sawblade, too, faces the worker and the wood is pressed up to it, whereas in the handframe the sawblade faces away from the worker, and cuts into the wood.

Choice of Machines

All machines work on the same principle, and there are several all built by Hobbies Ltd. from which to choose. The Gem is the cheapest of them all, and next to it comes the A1. The latter is an exceedingly popular machine, being heavily built, free from vibration and with strong wooden arms trussed up at the back to keep the proper tension on the sawblade.

A still better machine is the Triumph, which is exceedingly sweet running because it is fitted with ball bearings, and several other improvements.

The actual choice of machine largely depends on what the worker can afford, but he should certainly buy the best he can, although all are exceedingly good value.

It may be that when the machine first arrives, the small cramps holding the sawblade shackles to the arms, have become slightly pushed back. This will cause the blade to run out of true. A simple test should be made before you first undertake any work.

Stand a piece of wood about 1 in. thick behind the blade when it is at the lowest point of its stroke. Let the wood just touch, and then, by hand, turn the wheel so the blade comes upwards. It should, if fitted correctly, touch the block of wood at the top and bottom of its stroke, leaving it slightly between.

If, however, it touches the block at the top of the stroke and not at the

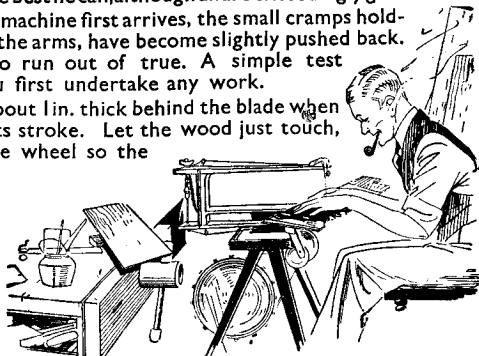

bottom, the clamp holding it to the arm must be moved slightly backwards. Unfasten the nut with a spanner, and gently tap the holding clamp back. Tighten the nut temporarily, and test the blade out again against its piece of wood. If it is now correct, tighten the nut up finally. (See Fig. 1.)

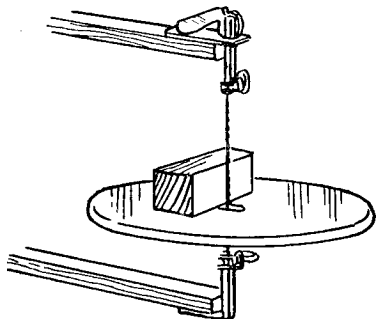

Fig. 1.—A block laid for testing.

curved lines, and the simple exercises shown earlier in this book will do well to follow on the machine.

When the machine arrives the top saw tension lever may be the reverse way round, but it is a simple matter to lift it slightly in the square socket and turn it round so it can be operated correctly. The lever, of course, is thrown forward to allow the sawblade to be inserted, and then turned back to the position shown, for tightening up.

The dust blower is also a useful accessory which can be obtained and easily fitted by the worker. One finds the dust accumulating round the cutting line when working at speed, and the worker usually has to blow this because it is an automatic blower which is fixed to the front underside of the away to see where he is going. This little accessory does away with the trouble, arm as shown.

Oil Moving Parts

It is a good plan before beginning work on a new machine to give it an oiling. A touch of oil can also be added occasionally, but not too frequently. For instance, the large wheel bearing the belt should be oiled through a hole which will be found in the hub.

The arms themselves should not need any oiling, because they work on a special knife-edge washer, which reduces friction to a minimum. See that no oil gets on the leather belt.

The same remarks apply to any side play which the saw may have. Put the block of wood to the sawblade again, this time at the side.

When one first has the machine, of course, the operation of treading is a little awkward, but it is surprising how soon one gets over this, and can work the saw at a very high speed. Sit straight to the machine, and get a comfortable position before starting.

It is essential, too, to practice turning at various angles, and on

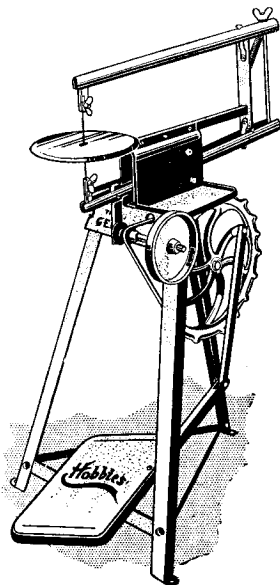

The popular Gem Machine.

The belt, by the way, may become loose after a considerable amount of usage. It should then be taken off, and the little metal clip holding the two ends together, taken out. About $\frac{1}{4}$ in. of the belt itself should be cut away, and then the two ends clipped together again.

The beginner with the machine is rather apt to attempt to force the wood on to the saw too hard, expecting the machine to do too much. The rate of cutting varies with the thickness of wood used, and one will do well to try out several odd pieces of wood of varying thicknesses to get used to this. Naturally, the saw will cut very much quicker through a $\frac{1}{8}$ in. piece than it will through $\frac{1}{2}$ in.

Easy for Bevel Cutting

Another big advantage of the machine is that bevel cutting can be undertaken for inlay or Antofret work. This is done by loosening the clamp under the table, and tilting the table itself to the required angle, tightening up the clamp again afterwards.

There is a swing of 19 ins. between the back of the machine and the saw-blade, so that work almost double this length can be undertaken by operating from both ends. That is, if you have a piece 3 ft. long, you can cut forward from one side, withdraw it from the table and then cut down the line from the other end of the wood until the part is severed.

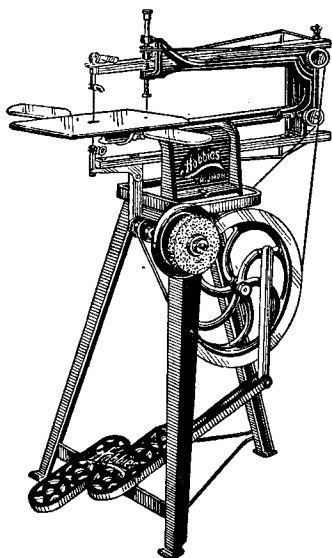

The Triumph Machine, fitted with treadle drilling arrangement.

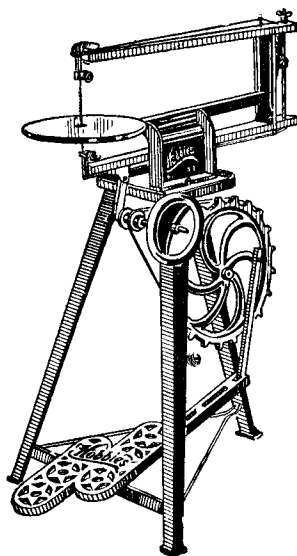

The solid and easy running Al.

In this connection, it is worth noting that side wings are obtainable which can be fitted to the table itself, and provide a larger surface.

As previously mentioned, the Triumph Machine is fitted with ball-bearings, which makes the machine run very much more smoothly. It is now possible to add these ball bearings to the other machines by substituting a metal pitman which contains a ball race as shown in Fig. 2.

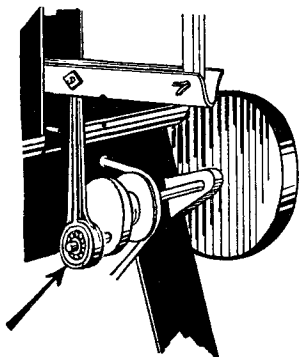

Fig. 2.—A ball-bearing fitting which can be added.

attachment is available on the Triumph as illustrated for small extra cost. It saves a very considerable amount of work because all holes can be drilled when treading merely by pressing the drill on to the wood.

The drilling apparatus is on a separate arm and a separate belt is connected to the flywheel which, of course, has a special double groove.

Automatic Drilling

The drill is raised above the work when not required and is easily disconnected by removing the belt. When in position the wood is placed beneath the point, and light pressure brings it down and through. The point cannot get damaged on the metal table because the drill point operates above a hole.

This chapter would not be complete without passing mention of the Imperial Machina, which is a different type, and one which appeals to many workers. It has a specially large platform for treading and an equally large flat table which accommodates sundry small tools.

The machine is fitted with a drilling attachment on a separate arm, fixed at a convenient point, handy for operating without any trouble.

Fully descriptive and illustrated lists of these machines are obtainable free on request.

The owner of a machine has a further advantage in that he can fit a glass paper disc which provides for cleaning his work by treading instead of by hand.

These discs are two circular metal plates, as illustrated below which can be fitted to all machines, except the Gem, by the side of the balance wheel. The latter is the solid metal wheel to the right of the cutting table, and the spindle of it is long enough to take the metal disc carrying the glass paper. (See Fig. 3).

Paper of different grades can be glued to the discs as required, and special clips are supplied to hold it in place whilst being glued.

On some machines, too, a treading device is provided for drilling. This

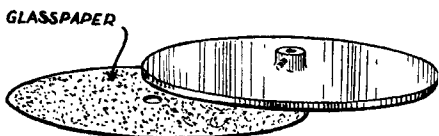

Fig. 3.—A glasspapering disc and wheel makes for easy cleaning.

DISPOSAL OF WORK

THERE are already hundreds who add to their income and pocket money by selling their work, and many who have a profitable all-the-year-round sale for their goods.

First of all, you must study your market and realize where and how you can dispose of your work. Then the question arises of what class of goods you can make best, and those which are easiest to sell. Then again, the season of the year has much to do with it. Not much use offering Calendars during February for instance, or a Football design in the middle of the summer.

How many friends have you who know that you can undertake this class of work? How should they unless you tell them or show some of your work as proof of your ability.

First of all, of course, whatever you do must be well done. It must be correctly cut and nicely finished. It must moreover, be good value. No use at all expecting people, particularly strangers—to pay double what they would in a shop just because *you* made it.

Have Samples

Start in a small way by having a few "samples" you can show them. Round about Christmas and the New Year the best sellers are undoubtedly those delightful little calendar pictures which are shown in the Hobbies Handbook and advertised frequently in Hobbies Weekly. They are easily and quickly made at the cost of a few pence and can be offered to friends who will frequently order several to give to their friends.

Make up a range of them, but do not sell those actual ones. Use them to get orders with and make more as you require them. Do not make the price too high, but add a little to the cost for your profit. A thing costing 3d. or 4d. to make should be sold for about 6d.

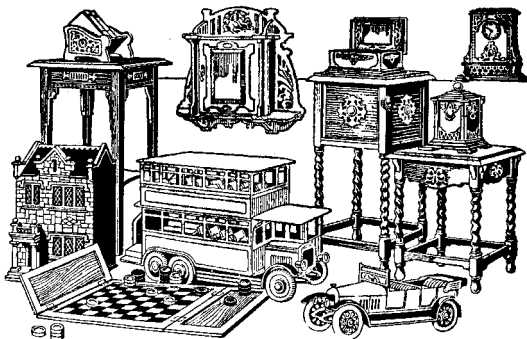

A range of suitable selling lines.

Offer them to local stationers or fancy shops and if they will not order immediately, ask them to make a counter or window display and pass the orders on to you to make more as they are sold.

Remember, in this connection, that the shopkeeper also has to make a profit, so you must cut your price low to get him interested in selling.

If you are a draughtsman, or have a friend who is one, get him, or her, to make up a display card (about 12ins. by 8ins. is a good size) with suitable wording in bold type. There should not be a lot of printing on it, nor should the lettering be small and illegible. Just "Quaint Calendar Pictures" or "Novelties in Calendars" should be sufficient, with the addition of the price if they are all the same.

Toys

Now pass to toys. There is a wide range of homely wooden toys shown in Hobbies Handbook which should have a ready sale if you make them at the right price. Toys, remember, are for kiddies, and their great joy is something bright and colourful. A horse and cart, a set of animals, a toy engine, a small doll's house, or little models can all be easily made and then painted up in bright enamel or poster paint to look cheerful and appealing.

Get the owner or manager of a toyshop interested by showing him what you can do, and offer him a display, or to make things to order as he requires them.

Then we come to articles of general utility. Such as the presses, the small trays, clocks, novelty cigarette delivery boxes, and the like. There are many fret designs one can make and here again, one's friends will frequently buy them for a birthday present.

Point out to these friends and relations the fact that you can do these and ask them to remember it next time they want a present for a birthday or wedding or some celebration occasion.

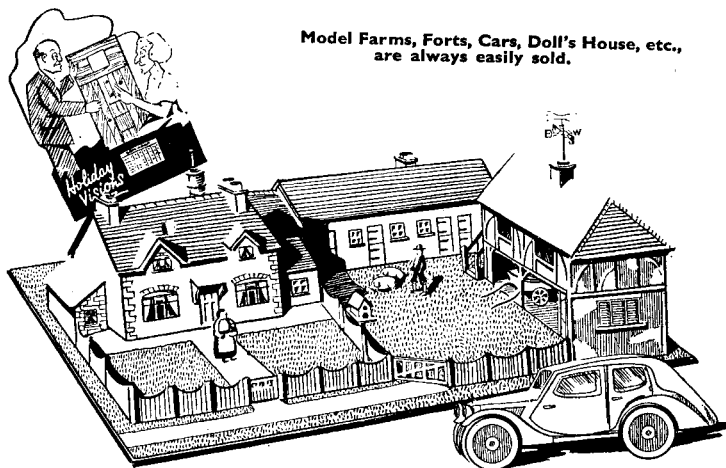

The question of the price you must ask is difficult to settle here because the wide range of subjects provides a wide range of values. The great point is not to ask too much. Keep an eye on the shop windows and notice values of goods offered there.

The time taken in making a thing will naturally effect the selling price. If you make, say, three small toys in one evening and sell them, say, at 1/- each, then you should be able to charge 2/6 or 3/- for a single article which took the same length of time.

Remember to make a note of the cost of materials for the article made and then add a little for your own time and profit. A thing which costs, say 2/6 to make should be easily sold for about 3/6. Or if a thing costs 10/- to make, then you should add about 2/6 for trouble and profit.

Study the Occasion

A big point to remember is to study the requirements of the people to whom you are going to sell. If a wedding present is wanted offer a clock, or a barometer, or a cake stand. If a lady wants to give a man a present suggest a cigarette box, or a tie press or a stud box.

Then there are certain specialized designs worth thinking about. A local place of worship may be wanting a hymn board, an amateur musician in a dance band will like to buy a one-string fiddle or a ukulele.

Even models can be sold to suitable people or shops. The model of a colliery would appeal to a coal merchant for his window; the several liner designs would be an excellent advertisement for a shipping line office counter. Or what about a model house to sell to an estate agent or builder?

Get a little notebook and paste in it the pictures from Hobbies Handbook or Hobbies Weekly of a range of articles you can make. Do not show the cost of the wood, etc., but write under it the price you charge for supplying the completed article.

In addition you should have a full catalogue in which you can see at a glance what it would cost to make such and such an article. Then if a customer asks for any particulars for a piece of work, you can refer to it in a minute and tell him what you can do.

Many workers, too, have small private cards done with their name and address upon them and stating that Fretwork, Toys, Models, etc., can be made to order. These cards are quite useful to hand to friends who are interested, and they only cost a small sum at any stationers or printers. Then too, you can have note heading done the same as ordinary business houses, as well as cheap hand-bills.

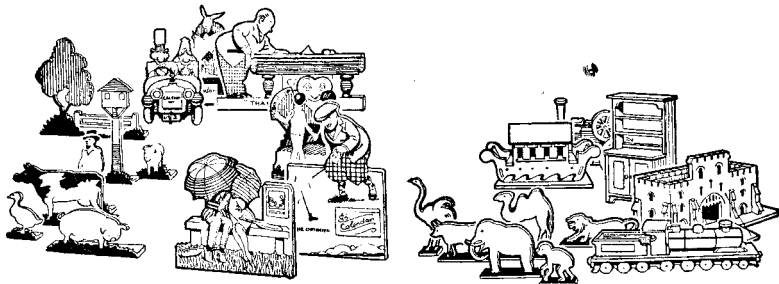

Toys, Cut-out Animals, Calendar Pictures and small novelties are always popular.

A HOBBIES CLUB

It would not be right to close this book without a short chapter on the question of co-operative work where several people with a similar enthusiasm can get together for mutual benefit.

There are various ways and means of doing this, and the worker who is keen will naturally desire some helpmate to share his work and pleasure. Two heads are undoubtedly better than one in fretwork as in most other cases.

Fretwork is one of those hobbies where you can work and talk at the same time, so some happy times can be spent doing both. Then think how much more work can be done if two or three are co-operating, and how much easier it is to increase your output to mutual advantage.

Get Help

So often one is just itching to go on with another job of cutting when you know all the time you should really clean one piece up first. That is where a helpmate can be so helpful, for they can be carrying on with the cleaning whilst you get on with the other job.

If you can, therefore, get some pal interested in fretwork with you, and share all your jobs together. You can talk over what to do next, help each other in the preparation, then complete the job in half the time taken if you were doing it alone.

SUBSCRIPTIONS									
NAME	DATES.								
	<table border="1" style="width: 100%; border-collapse: collapse;"> <tr> <td style="width: 10%; height: 20px;"></td> <td style="width: 10%; height: 20px;"></td> <td style="width: 10%; height: 20px;"></td> <td style="width: 10%; height: 20px;"></td> <td style="width: 10%; height: 20px;"></td> <td style="width: 10%; height: 20px;"></td> <td style="width: 10%; height: 20px;"></td> <td style="width: 10%; height: 20px;"></td> </tr> </table>								

A book for weekly payments.

LOAN BOOK		
NAME	MATERIALS	DATE
<i>W. J. Smith</i>	<i>1 Drill</i>	2.6.33
<i>W. J. S.</i>	<i>1 Book</i>	
<i>S. James</i>	<i>1 Model</i>	
	<i>1 Plane</i>	24.6.33

For goods and materials lent

Because there are two of you, does not mean you have to possess two complete sets of tools. Rather the other way round. Each can bring along certain tools or materials, and the work so arranged that whilst one is using certain things, the other can be doing another portion of the work.

Dividing Work

For instance, when one has started cutting out, the other can be sorting boards over, and pasting down the other patterns ready. Then when one has finished with the cutting frame, he can hand it over to his pal to use, whilst he proceeds with glasspapering and cleaning. Later, the pieces have to be put together and one can apply the glue and handle the patterns whilst the other puts them together.

So often two pairs of hands are necessary to handle the work to keep in place the various pieces and parts.

Then again, there is the sharing of expense on material and tools which reduces the actual outlay considerably. The work, too, can be done at each other's house alternatively if neither has a special den which is kept as a workshop.

WORK BOOK		
DATE	MATERIALS	COST

It is but a step further to the formation of a fretwork club, or a class where any member can belong and enjoy their work together.

Such a club provides a happy meeting ground for fellows with a common hobby, and the spirit of team work, of mutual aid and co-operation can be happily enjoyed.

Such hobby clubs, are of course, best run in conjunction with some of the existing movements which cater for the welfare of fellows—Y.M.C.A., Scouts, Boys' Brigade—Churches, etc. Where there are formations of this kind, there is usually someone anxious and able to act as leader who will guide, suggest and help the rest of the members. Such organisations, too, solve the usual difficulty of a workshop.

A Club

If you know of no such organisation in your district, you can still form a club for yourselves by talking about it amongst your friends. Suggest you all get together to talk it over, and arrange a meeting at home to settle first details.

Then you will probably find one of the company who has a spare room which can be converted into a workshop, or has a large shed, or knows a building which can be borrowed for the purpose.

Heating and lighting are essential, and you must decide how much will be needed in the form of subscriptions. There will be incidental expenses, too, on materials, tools, etc. until you have got going enough to make a profit.

Settle your weekly subscription and then appoint officers to be responsible for the conduct of the club. Have a chairman to rule the meetings, a secretary to keep control of the books, and a treasurer to look after the money side of the business.

Several books must be kept to ensure everything being in order. Exercise books ruled off as shown in the illustrations will do admirably, and they should be kept at the club and used regularly on each occasion.

If you cannot find some suitable independent workshop, try and arrange to meet at each other's houses, taking in turns at each meeting. Keep a list of the meeting places hung up so workers can know when and where the next occasion will be.

Remember, too, to keep the club neat and tidy. Have boxes or shelves in or on which books, papers, tools and materials can be kept. It is a good plan to appoint an "Orderly" on each occasion, and make him responsible for clearing up and cleaning the room before it is left.

Then, too, a definite Leader should be appointed either for one meeting or, say, for one month, and everyone to agree to abide by his ruling.

It is a good plan to arrange a form of exhibition of work at some period. Then the result of the work can be displayed and invitations given to friends and relatives to come along and see, with the object of buying or placing orders.



THE HOBBIES LEAGUE AND HOBBIES WEEKLY

FINALLY, there is a Hobbies League, with members all over the world, and which carries special privileges to those who join.

A striking certificate and bright enamel badge in two colours is issued when you have cut out a simple test entrance panel, and opportunity is provided to form clubs in districts and to correspond with other members all over the world.



The League Badge.

Norfolk, enclosing a stamp for 1½d. to cover return postage.

There is no annual subscription to pay, the only fee being 6d. when you first join and that does not really cover the value of the badge and certificate which is supplied to you.

Because of the increased postage abroad, the fee for joining members living outside the British Isles is 1/-, but their privileges are the same as any other League Members.

Notes and news of League activities, as well as photographs of Members and their work appear in Hobbies Weekly. This journal is the official organ of the League and should be taken regularly by all Members.

There is a special Hobbies League Pen at a reduced price and Notepaper and Envelopes are provided for the use of members.

Full particulars for joining are given in a special description booklet telling you all about it, and this also contains the pattern of the small piece of fretwork which forms the entrance examination. The book is free on request, and you should write for one to The Registrar, The Hobbies League, Dereham,

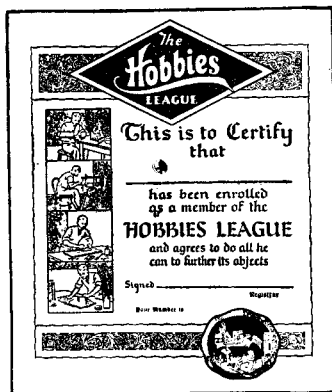

The League Certificate.

The Weekly, of course, should be taken by all fretworkers because free patterns are given in every issue. These designs cost 4d. each if purchased after the currency of the Hobbies, but are presented free when the copy is published.

Moreover, the Hobbies Weekly is full of helpful hints and practical articles on how to make and how to do subjects and provides a mine of information to regular readers who like to be handymen and craftsmen.

Any questions arising out of your work will be willingly answered by the Editor who is always ready to help a craftsman with any difficulties which arise.

The book is published every Wednesday and is obtainable to order from all newsagents and booksellers.

If you have no shop near or prefer to have the copy by post, it will be sent regularly for three, six or twelve months to order. Particulars of these subscription rates are free on request, with any other information desired to The Editor, Hobbies Weekly, Dereham, Norfolk.



Fretwork — cuts out dull evenings

Make Profit with a Fretmachine

You may be happy with a handframe, but you can never get the quantity made, or undertake to complete the work so quickly as if you had a machine. A Hobbies Machine lasts a lifetime—imagine the profit it would earn and the pleasure it would give you during that period. They are made from standardised parts so that if anything becomes broken it can easily and immediately be replaced. The machine is made in our own factory, by skilled workmen, and each one is tested before it is packed in a crate and dispatched.

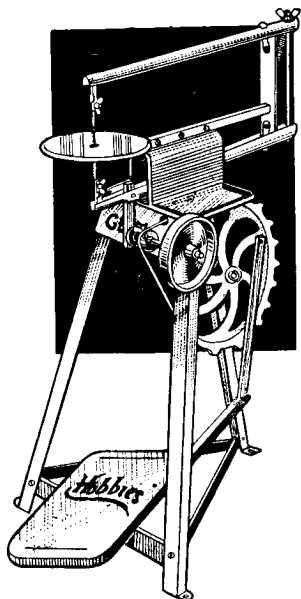

*Write for
illustrated
Leaflet*

HOBBIES GEM MACHINE

The finest cheap machine on the market, made of the best quality material and containing all the latest improvements. Steel arms which cannot warp or twist, a new compound lever tension device on the top arm, a spring to raise the arm when a saw breaks, a nicely rounded table in polished steel, a heavy balance wheel to ensure free running and easy treading. There is no hard work attached to the machine, and work 18ins. long can swing between the saw and the frame. The whole machine is rigid, but light enough to carry about; it is supplied ready to use, with design, spare saws, etc..

You can try this machine for yourself at any Hobbies Branch, or an illustrated leaflet with full particulars sent on receipt of postcard to

HOBBIES Ltd., DEREHAM, Norfolk.