

INCRA[®]

PROJECTS & TECHNIQUES



BY PERRY MCDANIEL

www.incra.com



Projects; tips and techniques that benefit any generation of INCRA Fence System.



INCRA LS Positioner

FOUR Exclusive NEW INCRA Joints, plus FREE Templates for making the spectacular INCRA Double-Double Through Dovetail™ and INCRA Cornerpost Eagletail™

INCRA Jig Ultra

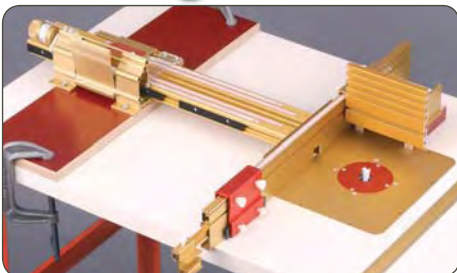

INCRA Jig Ultra Lite

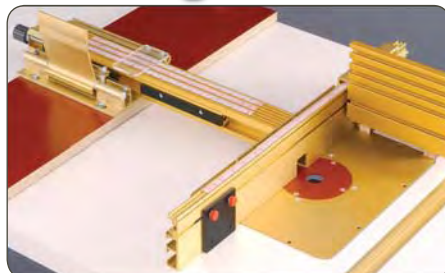

INCRA®

PROJECTS & TECHNIQUES

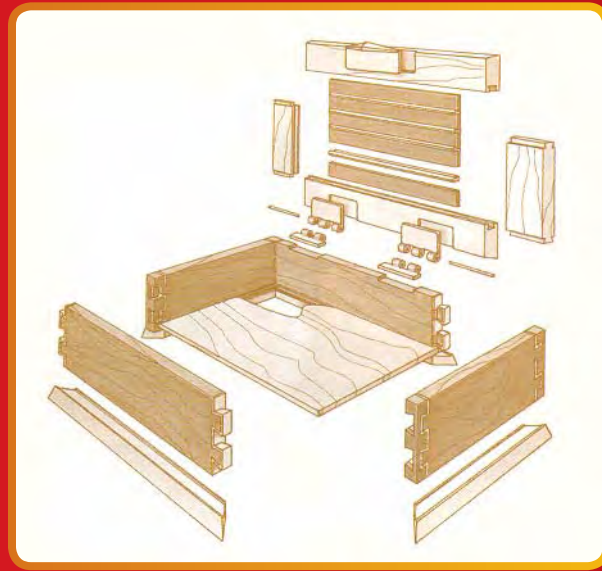

BY PERRY MCDANIEL

***14 ORIGINAL INCRA PROJECTS, 4 EXCLUSIVE NEW INCRA JOINTS AND A WEALTH OF TIPS
& TECHNIQUES THAT WILL TURN YOU INTO A REAL INCRA "PRO"***



PUBLISHED BY: TAYLOR DESIGN GROUP, INC., P.O. BOX 810262, DALLAS, TEXAS 75381

visit: www.incra.com



◀ **JEWELRY BOX** 138

A unique bevel cut lid and bottom frame give this elegant jewelry box, featuring the new INCRA Cornerpost Double Dove-tail Joinery, a distinctive oriental flair.



▶ **DECORATIVE PLAYING CARD BOX** 119

Strip laminations and the INCRA Double Dovetail Joinery give this piece a very distinguished look.



▶ **TRAIN WHISTLE** 74

No musical background required, this easy-as-pie project plays a two note harmony that no child can resist.



▶ **PLAYING CARD BOX** 114

This elegantly simple design features half-blind dovetail joinery and lift off lids.



▶ **SLIDE WHISTLE** 78

If you remember this fun filled whistle from your childhood, you'll want to make sure that your children, and theirs, remember it too!



▶ **TRIVETS** 88

A design inspired by the Egyptian pyramids, the intricate pattern on the floating panel is cut by synchronizing four different router bit diameters.



▲ **WOODEN DOMINOES** 98

No painted dots on these handcrafted dominoes - they're engraved! A true collector's set.



▲ **DECORATIVE DOMINOES BOX** 129

With the lid closed, the thin strips of wood in the top lamination align perfectly with details in the Double Dovetail Joinery of this striking box.

▲ **DOMINOES BOX** 124

An easy to build project designed to hold your favorite set of dominoes.



◀ **CUTTING BOARD** 82

Contrasting strips of wood arranged in a simple geometric progression create a tantalizing visual effect.



INCLUDES FREE TEMPLATES FOR MAKING THESE EXCLUSIVE NEW INCRA JOINTS.



▲ **INCRA CORNERPOST EAGLETAIL** 69

More than just a "dove" tail, the Cornerpost Eagletail will lift your woodworking skills to new heights.



▲ **INCRA DOUBLE-DOUBLE THROUGH DOVETAIL™** ... 55

One of the fanciest joints ever invented. Once you've mastered this, you're a certified INCRA PRO!



▲ **SLIDING DOVETAIL BOOKEND** 92

Decorative lamination techniques are combined with the natural wedging action of opposing dovetails to produce a functional and attractive bookstand for your desk or mantle.



▲ **BUSINESS CARD CASE** 106

Carry or display your cards in this streamlined case highlighted by an integral wooden hinge. Impressive!



▲ **TRINKET BOX** 132

A dramatic box design outlined with contrasting woods and featuring a laminated raised panel lid, INCRA wooden hinges, and a striking angular lift handle.

EXCLUSIVE NEW
NEW JOINERY
INCRA JOINTS



▲ **INCRA CORNERPOST DOVETAIL™** 62

A dramatic and very versatile joint that can be made with any of the standard INCRA dovetail templates.



▲ **INCRA CORNERPOST DOUBLE DOVETAIL™** 65

This attractive variation of the Cornerpost Dovetail transforms the INCRA Double Dovetail into a decorative joint visible from all sides.

INCRA ROUTER TABLE PLANS 15

TIPS & TECHNIQUES ▾

GETTING STARTED 10

CENTERING & ZEROING 22

STOCK THICKNESS, ROUTER BIT & TEMPLATE SELECTION 25

BOXES MADE TO ORDER 27

INSTALLING BOX BOTTOMS 30

LINING WITH LEATHER 34

COMPARTMENTS & LIFT OUT TRAYS 36

STRIP LAMINATIONS 41

MORTISING TEMPLATE FOR INCRA WOODEN HINGES 44

VERTICAL HOLDING/TENONING JIG 48

RAISED PANEL CUTS 51

PROJECTS & TECHNIQUES

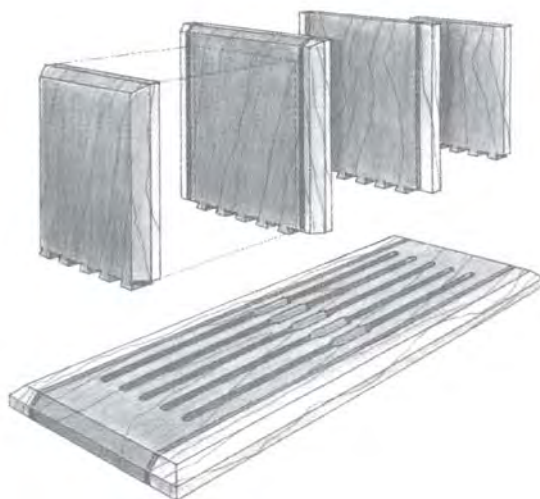

BY PERRY MCDANIEL

Written by:

Perry McDaniel

Illustrations by:

Perry McDaniel & Alice Taylor

Book Design by:

Alice Taylor & Cindy Liang

Photography by:

Marissa Wallace

© 2009, Taylor Design Group, Inc.

All rights reserved.

No part of this publication may be reproduced in any form, or by any means, without written permission from Taylor Design Group, Inc.

Printed in the U.S.A.

INCRA is a registered trademark of Taylor Design Group, Inc.



PUBLISHED BY:

TAYLOR DESIGN GROUP, INC., P.O. BOX 810262, DALLAS, TEXAS 75381

visit: www.incra.com

INCRA products are protected by one or more of the following U.S. Patents: #4,793,604, #4,930,221, #5,195,730, #5,275,074, #5,423,360, #5,716,045, #6,237,457, #6,557,601, #6,672,190.

CONTENTS:

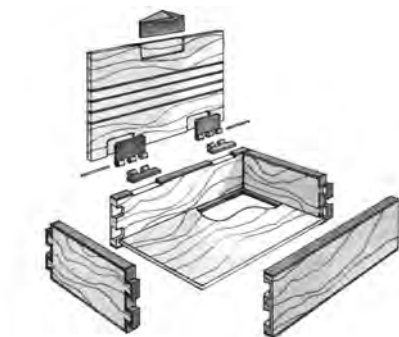
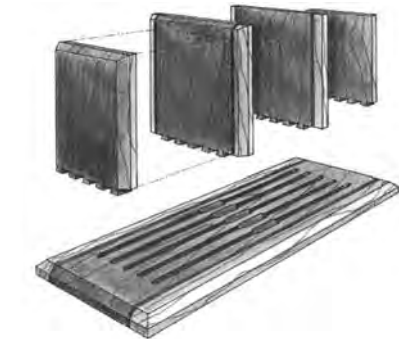
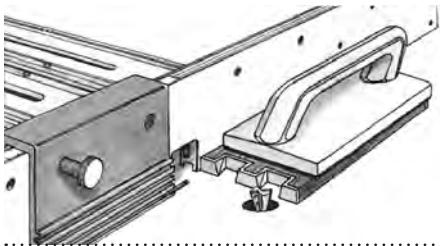
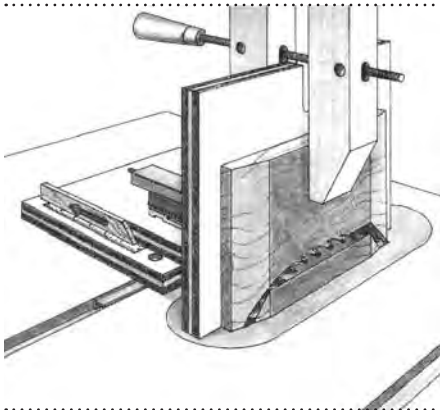
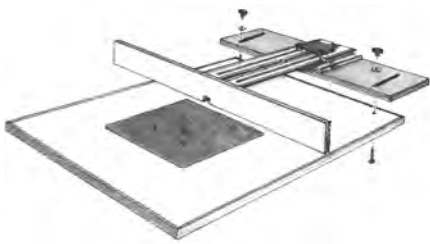

I. INTRODUCTION	7
Safety	8
II. GETTING STARTED	10
Glossary	11
Router Table Components	12
Custom INCRA Router Table Top	15
III. TECHNIQUES	21
Centering and Zeroing	22
Stock Thickness, Router Bit and Template Selection	25
Boxes Made to Order - Calculating Stock Length for Joinery	27
Installing Box bottoms - Stopped Mortises	30
Lining with Leather	34
Compartment and Lift Out Trays	36
Strip Laminations	41
Hinge Mortising Template	44
Vertical Holding/Tenoning Jig	48
Cutting Raised Panels with Your Vertical Holding Jig	51
IV. INCRA JOINERY	52
INCRA Double Joinery Without a Thickness Planer	53
INCRA Double-Double Through Dovetail™	55
INCRA Cornerpost Dovetail™	62
INCRA Cornerpost Double Dovetail™	65
INCRA Cornerpost Eagletail™	69
V. PROJECTS	72
NON-JOINERY PROJECTS	73
Train Whistle	74
Slide Whistle	78
Cutting Board	82
Trivets	88
Sliding Dovetail Bookstand	92
Dominoes	98
Business Card Case	106
BOXES	113
Playing Card Box	114
Decorative Playing Card Box	119
Domino Box	124
Decorative Domino Box	129
Trinket Box	132
Jewelry Box	138

I

INTRODUCTION

Measuring accuracy and cut placement are two important keys to woodworking success. One improperly placed cut is often the difference between a family heirloom and a piece of firewood. When I think about the many fine examples of woodworking from the days before electricity, I can't help but marvel at the sheer mastery and resourcefulness of the traditional craftsman. Measuring with little more than sticks of wood and hand cutting every piece, he developed the ability to be both confident and consistent with the relationship between measure and cut.

Today's woodworker is not unlike the traditional craftsman of yesterday. We both rely on the techniques, tools and teachings of our day, each of us aspiring to make our work the best that it can be. We work to develop our skills and methods and utilize the best of our resources to find the safest and most accurate methods of production.

In our search for the perfect cut, we have seen our tools evolve before our very eyes. Many hand tools have been replaced by power tools making cutting operations quicker and easier. The wooden ruler and carpenter's square have been replaced by the machinist's rule with graduations in thirty-seconds and sixty-fourths and by the dial caliper with graduations in thousandths. Table saw fences have been rethought to make positioning with a ruler a thing of the past. Machine shop accuracy in the woodshop has finally come of age.

Of course, hand skills still remain an important part of woodworking artistry, but if yesterday's craftsman could have used a table saw, set the fence to blade distance with a quick motion of the hand, and made a perfectly placed cut, I believe he would have done so. He would have taken advantage of the best that woodworking technology had to offer.

Whether your INCRA System is the first generation "Original", the feature laden LS Positioner or any model in between, each offers true machine shop precision and repeatability, a fundamentally new concept in the woodshop. What is this repeatability? It's being able to make a cut at say, 1" from the edge of a board, move the fence to another position, and then come back two hours or two days later and duplicate that cut to within one thousandth of an inch or better. It provides even the beginning woodworker with cut placement control rivaling that of the most talented master craftsman. Repeatability is a dream come true for the woodworker, regardless of skill level.

The projects in this book were designed to take advantage of the unique capabilities of your INCRA Positioning System. They illustrate a few of its many applications in the woodshop, from use at the router table and table saw to the drill press. I hope that you will find these projects interesting; more importantly, I hope they will provide you with food for thought and become a stepping stone on your path to discovering the many intricacies of woodworking using this amazing new tool.

Safety

Never forget...

- Safety glasses for eyesight protection
- Earmuffs/earplugs for hearing protection
- Push blocks/push sticks for finger and hand protection
- Dust masks for respiratory protection
- Read all Owner's Manuals and follow all safety instructions.

By using these simple safety practices and good common sense you will afford yourself many years of enjoyable woodworking. Above all, remember - The next power tool you turn on is the most dangerous one in your shop! Stop and think before you make the cut.

Bit Rotation and Stock Feed Direction

At the router table there is one safety practice that should be covered thoroughly. It concerns the understanding of direction of bit rotation versus stock feed direction. By far, the table mounted router is the most versatile stationary tool in the shop, with its ability to perform a great variety of cutting operations. Take the time to familiarize yourself with the feed direction necessary for each of the different cuts so that you may safely utilize this multi-faceted tool.

Edge Forming/Rabbets

Note: In all of the examples to follow, you should use a good rubber soled push block!

One of the most common operations at the router is edge forming. A rabbeting bit, roundover bit, and roman ogee bit are three examples of edge forming bits. They are available with or without roller bearing guides. The important thing to remember when considering feed direction is to always feed opposite the direction of bit rotation. In Example 1, a bit with a roller bearing and the proper feed direction are shown. Can you see that by placing the stock on the right hand side of the bit and using the same feed direction, the cutting rotation would pull the stock into the cut and thereby decrease your ability to control the cut?

An edge forming bit without a roller bearing requires the use of a fence to support the stock throughout the cut. In Example 2, the bit is partially recessed in the fence notch and the proper feed direction is shown. If the stock is fed from the opposite direction, the bit will kick the stock away from the fence and pull it from the operator's hands.

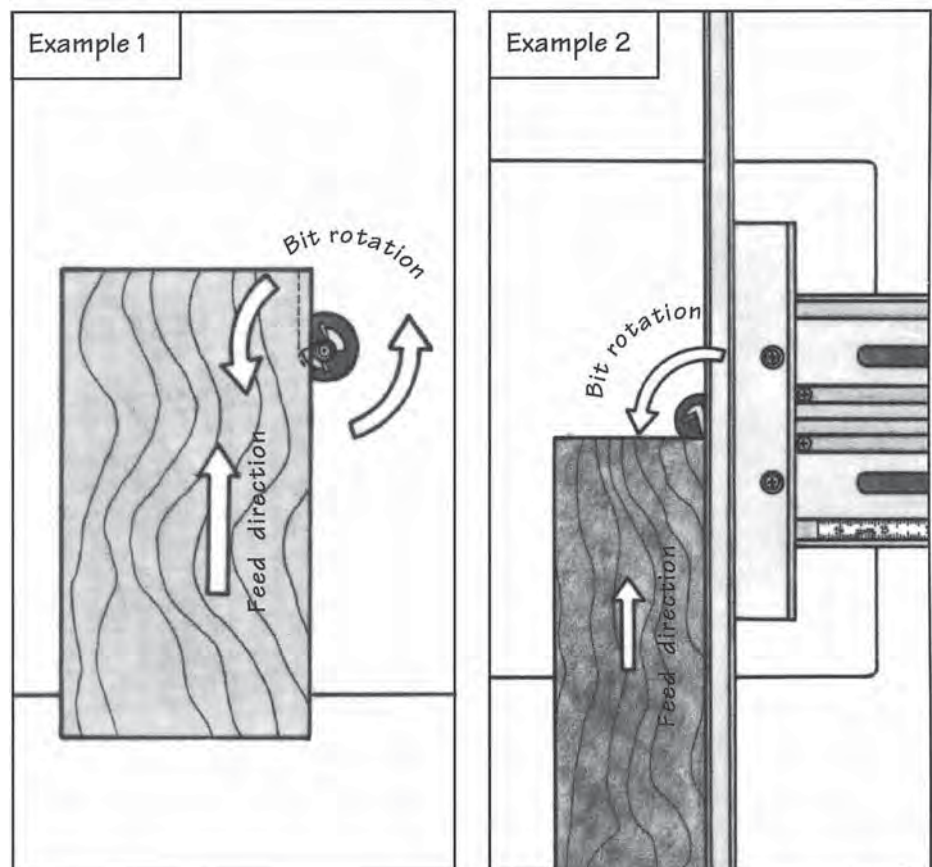

Grooves and Dadoes

Cutting grooves or dadoes is another common router table operation. The straight bit and the dovetail bit are two examples of groove forming bits. These bits can be used to cut grooves with the stock lying face down on the table, but they are also used to cut across the end grain of stock clamped in a vertical position on a right angle fixture. These vertical cuts are often used in joinery. In Example 3 the proper feed direction is shown. The fence should always be on the right hand side of the bit. It would appear that, since there is stock on both sides of the cut, feed direction would not matter. But there is more to this picture than meets the eye. As you see in Example 3a, the cutting wing of the bit takes out fingernail shaped bites as the stock is advanced. The arrows denote the direction of the force applied by the bit as it rotates. This sideways force pushes the stock firmly against the fence throughout the cut. If the feed direction is reversed and the stock is fed from the opposite direction, the rotational force of the bit pushes the stock away from the fence making it quite impossible to control the cut. See Example 3b.

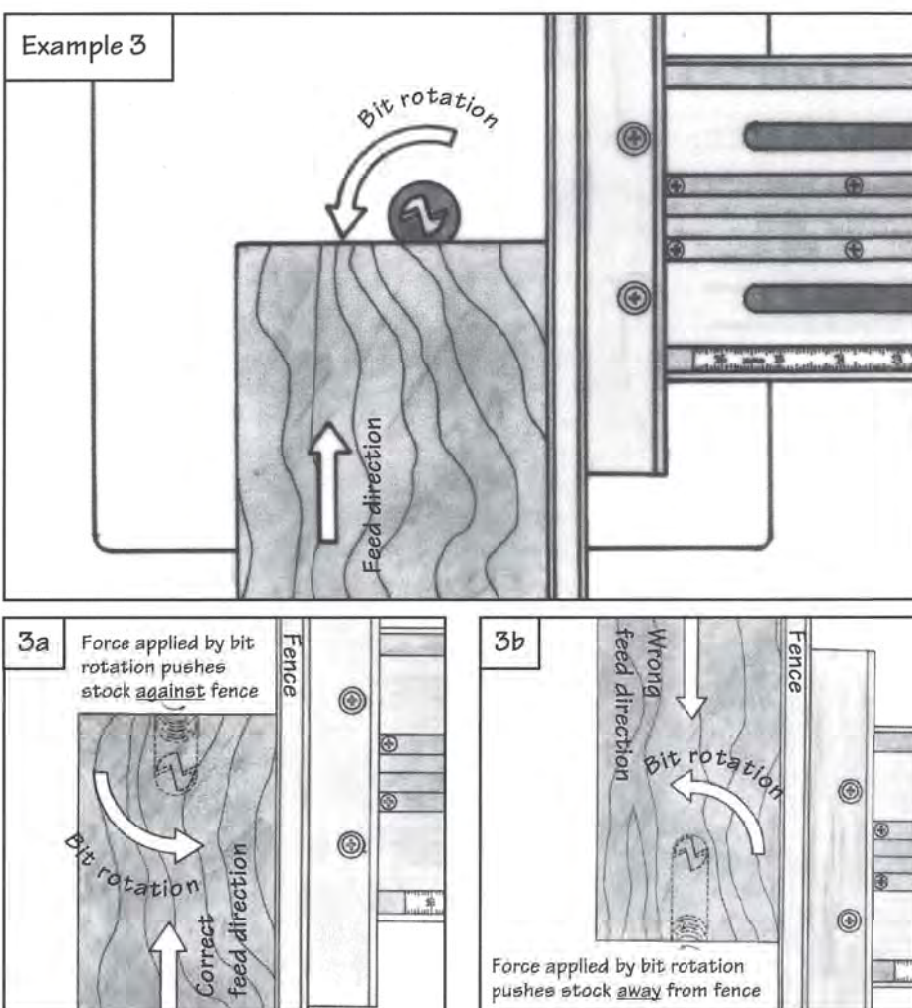

Widening a Groove

Sometimes you may find it necessary to widen a groove with a second pass. The feed direction will then depend on which side of the original groove is to be widened. For clarity I always refer to the side of the groove closer to the fence as the inside edge of the groove. The side farther from the fence is the outside edge of the groove. If the outside edge of the groove is to be widened, the stock should be pushed forward. If the inside edge of the groove is to be widened, the stock should be pulled backward through the cut. See Example 4.

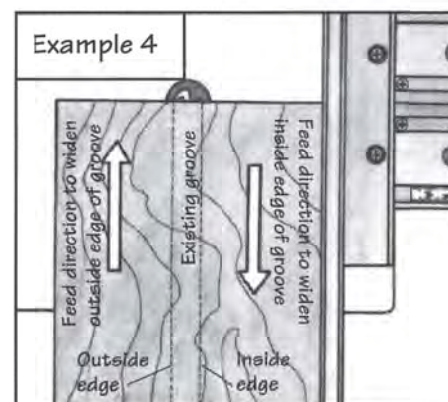

Rabbeting the Outside Edge

In making the trim section which meanders through the corners of the double-double box joint and the double-double through dovetail, it is necessary to cut a rabbet on the outside edge of the stock. If the stock is pushed forward it can easily become "pinched" between the fence and bit. The best way to handle this particular cutting operation is to move the fence back so that the bit is only cutting $1/32$ " into the outside edge. Now pull the stock backward through the cut. Advance the fence toward the bit $1/16$ " and repeat the pull-cut. Keep advancing the fence in $1/16$ " increments until the desired rabbet width is achieved. See Example 5. Using this method will always yield a very safe and clean cut rabbet.

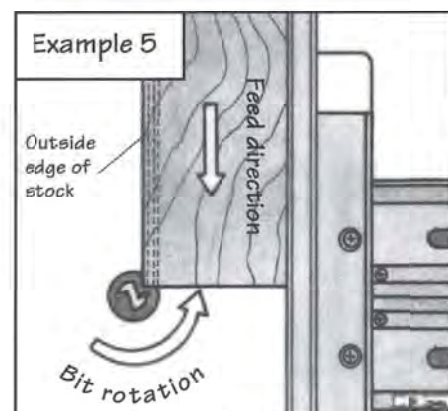

II

GETTING STARTED

This chapter is devoted to getting the most out of your INCRA System, and the ideas and projects presented in this book. We'll begin with a glossary to help with the terms and references used throughout the text. Then, we'll have a look at the components of a router table system: the fence, the router, and the table top. We'll discuss what to look for in each component and what to look out for. Also included are plans for a simple but very functional INCRA JIG router table top and an interesting clamping system for your INCRA JIG's plywood base.

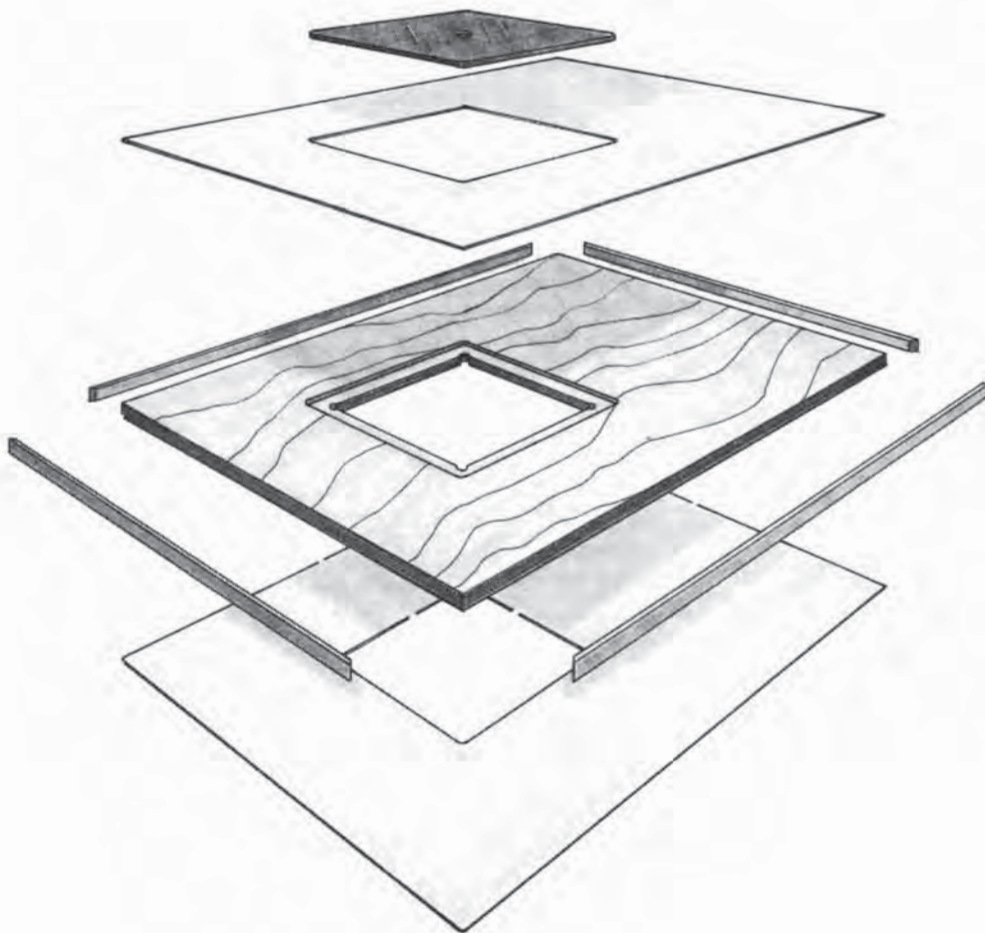

Glossary

Backing board -

A piece of scrap stock that is placed behind a board that is being cut to prevent splintering as the blade or cutter exits the back face of the board.

Centering -

A fence alignment process which establishes the center of a board's width, length or thickness as the point from which all cuts are measured.

Chamfer -

- 1) A 45 degree bevel along the edge of a piece of wood.
- 2) To cut such bevels.

Counterbore -

- 1) To drill a two staged hole that allows a bolt or screw head to sit below the surface of a piece of wood.
- 2) The hole itself.

Crosscut -

A through cut made across the grain of the board. A crosscut reduces a board's length.

Dado -

A groove cut across the grain of a board.

Double Sided Tape -

Paper backed tape with a very aggressive adhesive on both sides. I use #ST501, manufactured by

SpecTape of Texas (1-800-442-1338), also available from most INCRA dealers.

End grain -

The surface of a board exposed after making a cut across the grain.

Feed -

To push a board in a controlled manner towards a moving blade or cutter.

Fence edge -

A marked surface of a board which is placed against the fence when preparing for a cut.

Grain -

The general direction of the fibers of wood in a board.

Groove -

A long channel cut parallel to the grain of the board.

Infeed -

The part of a machine's work table that is in front of the blade or cutter.

Kerf -

Width of the slot cut by a saw blade.

Lamination -

A component board made from strips of wood glued together.

Miter -

- 1) An angled cut across a board (usually 45 degrees).

- 2) To cut an angle across a board.

Outfeed -

The part of a machine's work table that is behind the blade or cutter.

Pin section -

The part of a dovetail joint that is made by cutting stopped grooves into the end grain with the stock oriented face down on the table.

Push block -

An "L" shaped or rubber soled block (usually equipped with a handle) used to safely feed a board into a blade or cutter.

Push stick -

A notched stick used to feed a board into a blade or cutter.

Rabbet -

- 1) An open channel or groove cut along the edge or end of a board.
- 2) To make such a cut.

Resaw -

- 1) A through cut made parallel to the grain which reduces a board's thickness.

Rip -

A through cut made parallel to the grain of a board. A rip reduces a board's width.

Scoring pass -

A light 1/32" wide rabbet made with various router bits. This light cut creates a splinter free entry into the face, edge or end of a board. (Usually followed by subsequent wider cuts.)

Stopped groove -

See Stopped mortise.

Stopped mortise -

A mortise which does not pass all the way through the thickness of the board. (Also called a stopped groove).

Tail section -

The part of a dovetail joint that is cut across the end grain with the stock clamped to the right angle fixture.

Trim section -

- 1) The contrasting piece of wood that meanders through the various INCRA "Double" or "Double-Double" joints.
- 2) The blank from which such pieces are cut.

Zeroing -

A fence alignment process which establishes the edge, end or face of a board as the point from which all cuts are measured.

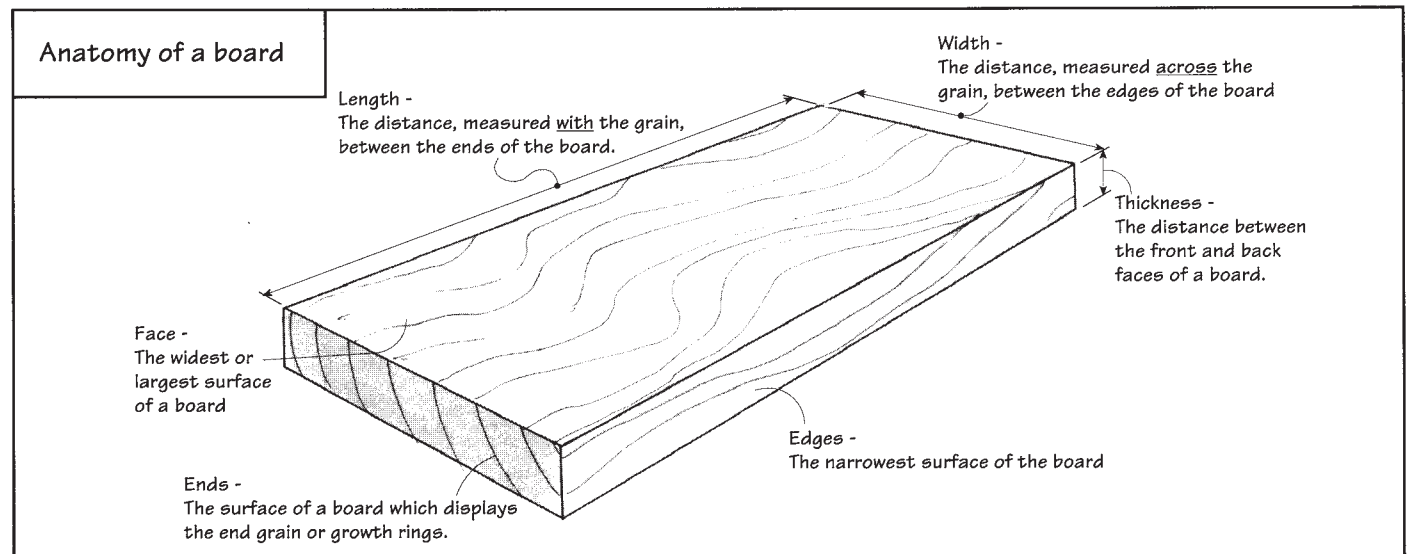

Router Table Components

Since the introduction of INCRA JIG in 1987, a workshop revolution has begun, dramatically changing not only the way we use many of the tools in our shops, but also the tools themselves. To understand more about these changes, what they have done for the woodworker, and what you can do to get the most out of your router table setup, let's look at the router table's three main components: the fence, the router, and the table top.

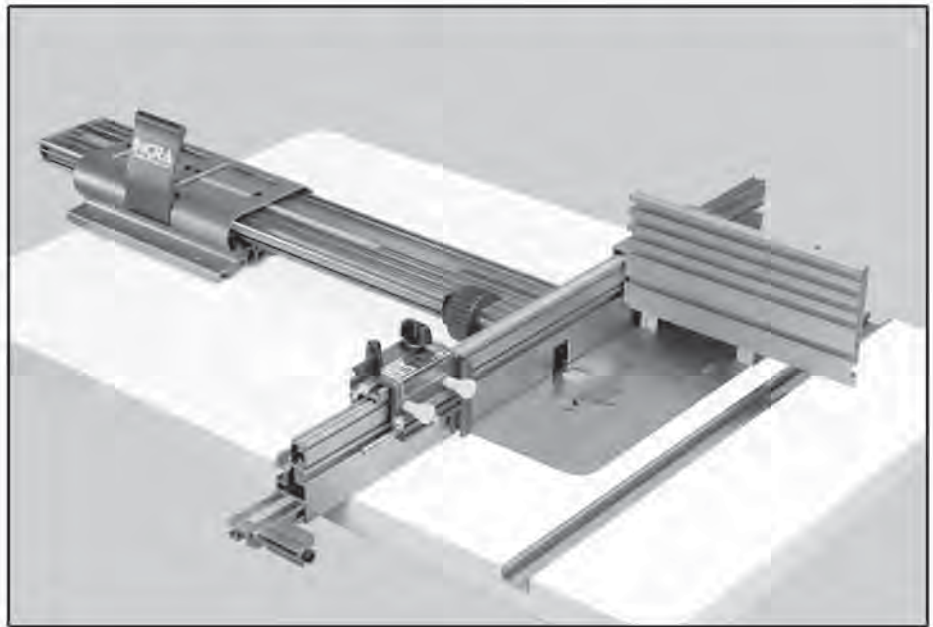

The Fence

From the weekender to the professional, INCRA JIG has presented a welcome alternative to the inaccurate positioning devices of yesterday. No doubt many of you will remember clamping a piece of wood across your router table as a fence and setting the fence to bit distance with a ruler. How about the trouble you went through a few days later to duplicate that setup?

At best, it was an unreliable, tedious, and time-consuming process. INCRA JIG has changed all of this, making fence positioning and repeat setups a simple matter of a quick motion of the hand and a few seconds of time. And what about joinery?

Unless you are among the group of dedicated individuals who have devoted months, even years, to the study and perfection of the techniques necessary to hand cut joinery, your selection was limited, that is, before INCRA JIG. Sure, there are many devices out there that can help to produce dovetails or box joints, but many of these will make only one or the other joint. And of those that can be used to produce both joints, there are a very limited number of patterns available. INCRA JIG introduced a

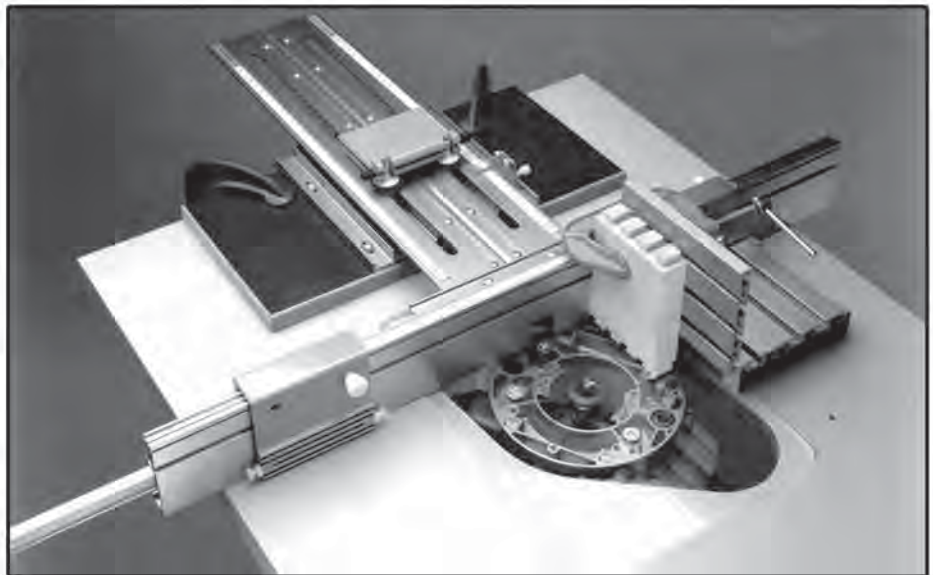

completely new method for joinery. Instead of holding the often heavy and cumbersome router in our hands and guiding it over the wood, we've mounted the router in a router table and used the INCRA JIG as a very accurate fence system to position the wood for the cuts. And, because of INCRA JIG's incremental movement, this method of cutting joinery offers an almost infinite variety of pin and groove spacing.

Accuracy is addictive. Once you have experienced the accuracy and repeatability of an INCRA JIG Positioning System, you'll find it difficult to return to those former methods and techniques. I have often sat holding the Double-Double Box Joint or the INCRA Double Dovetail in my hands, quietly reflecting on the techniques I have used to produce this beautiful joint, and thinking "I have made this. I wonder what else I could do?" The possibilities are inspirational.

The Router

Have you been shopping for a router lately? Scary, isn't it. Unless you've got a black belt in shopping technique, you are almost sure to end your day of shopping with nothing more than a headache. Even the most hardened of tool collectors will shudder at the thought of wading through the multitude of specs and features on routers manufactured by Black & Decker, Bosch, Dewalt, Elu, Freud, Hitachi, Makita, Milwaukee, Porter Cable, Ryobi, Sears Craftsman, and Skil, each of which produces from two to ten different models. Just where do you start?

First of all, any router will work. If you are willing to spend a good deal of time and patience on installing your bit, setting the approximate depth of cut and then trial and error cutting until you get the correct depth, you can get by with any standard non-plunge router. I have tried that route, and though my patience ran thin on several occasions, it was not until I toasted the bearings on my first router that I decided to do something in search of convenience. I purchased a plunge router. Here are the features I looked for:

Fine Adjustment Knob

The plunge router has a distinct advantage over the standard router in depth of cut control and adjustment. The depth of cut control begins with a standard feature found on all plunge routers known as a plunge limiter. This handy addition limits the upward travel of the carriage when the plunge lock is released. The plunge limiter usually consists of a threaded rod attached to the base of the router. The threaded rod passes through a hole or notch in the carriage and is topped by a nut. When you mount the router upside down in your router table the plunge limiter serves two purposes. First, after

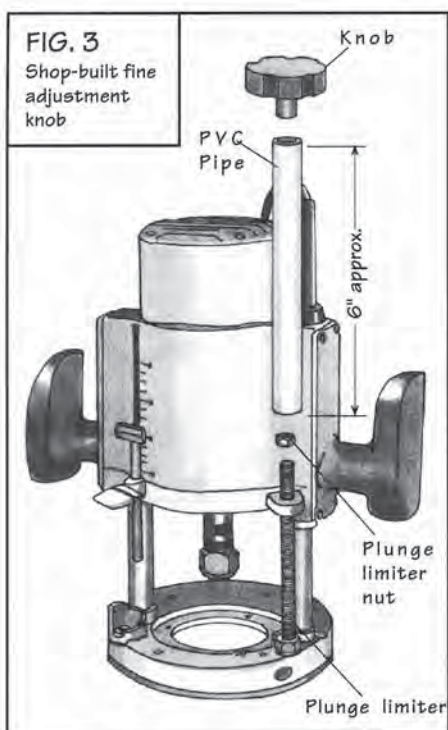

releasing the plunge lock, the limiter keeps the plunge router springs from throwing the carriage to the floor. Secondly, the nut on the limiter provides a means by which to raise or lower the carriage without having to fight the springs. Turning the nut clockwise increases the depth of cut, counterclockwise lowers the depth of cut. Of course, the nut is virtually impossible to turn by hand because of the pressure exerted by the springs, making it necessary to keep a wrench close by. This is where the fine adjustment knob comes into play.

The fine adjustment knob is a feature that has in recent years become more of a standard, rather than optional, attachment. It is simply a short length of tubing, one end of which captures the nut on the plunge limiter. To the opposite end of this tube a large knob is attached. The large knob provides the mechanical advantage necessary to turn the small nut by hand, allowing the woodworker to instantly adjust the depth of cut without the bother of finding a wrench first. If you have a plunge router without this fine adjustment knob, you can easily make one by epoxying the nut from your plunge limiter into the end of a 6" length of PVC pipe. The inside diameter of the pipe should be just slightly larger than the outside diameter of the nut, so you might want to carry the nut with you to the hardware store to get the correct size pipe. Carve or turn a knob out of wood and epoxy it to the opposite end of the pipe. You'll want the knob to be about 2" in diameter. See Fig. 3. If you don't feel like making your own, contact your router's manufacturer. They may offer the fine adjustment knob as an option.

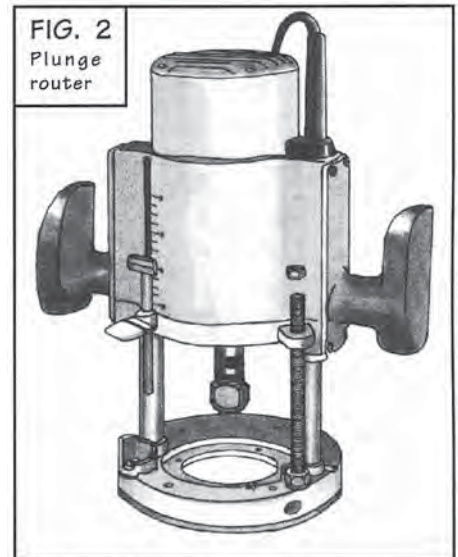

One company even markets an entire line of fine adjustment knobs to fit most plunge routers.

Spindle Lock

After getting both wrenches on your router's spindle and collet nut, do you ever remember which wrench to push and which to pull on the first try? I always end up tightening the collet when trying to remove a bit. It doesn't have to be this way. Many of the plunge routers on the market today have added "spindle lock" to their list of features. A spindle lock allows changing of router bits with a single wrench. In most cases, this means you'll be able to change the bit without having to remove the router from your table, a major improvement over the two-wrench system.

Plunge Lock

The plunge lock is a lever which enables the user to lock the router carriage at any given plunge position. This lever must always be locked before making any cuts. It must be unlocked before adjusting your depth of cut. In the router table, I found that the easiest plunge locks to use were those that unlocked by pulling away from the router base. Plunge locks that require pushing toward the router base will often lift the router and base plate right out of the router table. Of course, the most obvious solution to this problem is to attach the router table insert plate (the router's base plate) to the table top using a few screws. If you decide to screw the base plate down, you'll want to make sure your router will allow for bit changes without removal from the table.

The Table Top

Before INCRA JIG was introduced, most router tables were small benchtop models. The tables were set up to do one thing in particular - edge forming. Roman ogee cuts on picture frame stock, rail and stile cuts on frame and panel constructions, rabbets, chamfers, and roundovers - all of these cuts require that the fence be positioned directly over the bit. In that respect the small router table was adequate. But what if you wanted to cut a groove eight or ten inches from

the edge of the board. With a small table - not a chance.

Many of today's router tables have evolved into freestanding units featuring table surfaces large enough to accommodate the range of an INCRA JIG. In a pinch for space? There are several router table tops designed to take the place of one of the extension wings in your table saw. There is even one heavy duty model made of cast iron. If you

want to build your own router table, you can almost bet there has been a plan published in whatever woodworking magazine you subscribe to within the last couple of years.

Whether buying a router table, or building your own, the following section will provide you with valuable tips on the various components.

FIG. 4
Router table top

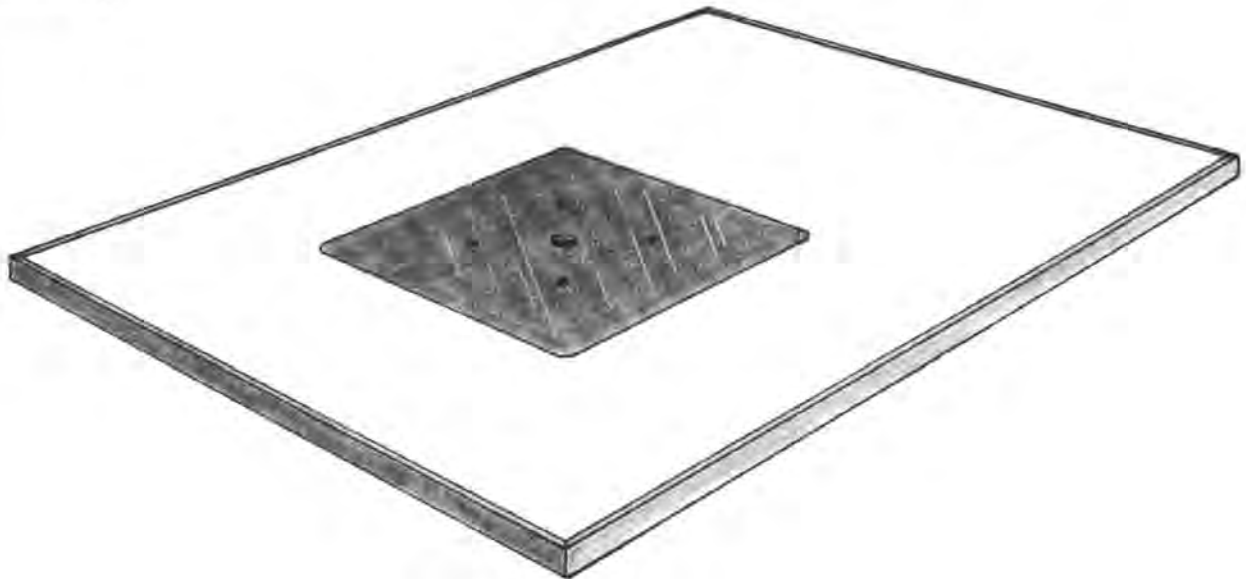

Custom INCRA® Router Table Top

The exploded drawing below shows the components of a router table top customized for INCRA JIG that you can build. The pieces in the drawing have been dimensioned if you would like to build this design, while the descriptive paragraphs offer design options. On pages 16-17 you'll find an article on routing the recess in your table top for the baseplate with some tips on how to achieve the elusive flush fit. And on page 18 I've included plans for a convenient clamping system for your INCRA JIG's plywood base.

BASEPLATE:

1/4" x 11" x 11"
Phenolic resin board
(NEMA Grade X)
Can be purchased at most plastic supply distributors or at your nearest INCRA Dealer. Acrylic may be substituted, but should be 3/8" thick to avoid sagging.

Note: 11" x 11" or larger baseplates are most common, but there's nothing wrong with using a smaller size if it will fit your router. The through hole for the router bit is centered on the plate. Keep the hole for the router bit as small as possible - 3/4" is a good size. If you need to use larger diameter bits, it is best to have a second plate with a larger diameter hole.

PLASTIC LAMINATE:

Available at most home improvement centers. Use contact cement to glue laminate to the table top and bottom, then trim the edges with a flush trim bit. The hole on both the bottom and top laminate is cut after gluing to the plywood.

EDGING:

Provides a moisture barrier to the edges of the table top. You could substitute plastic laminate here if you wish. The dimensions shown are for a 3/4" thick table top. If you use 1" MDF, use 1" wide edging. Apply the edging after trimming the top and bottom plastic laminate flush with the edges of the plywood.

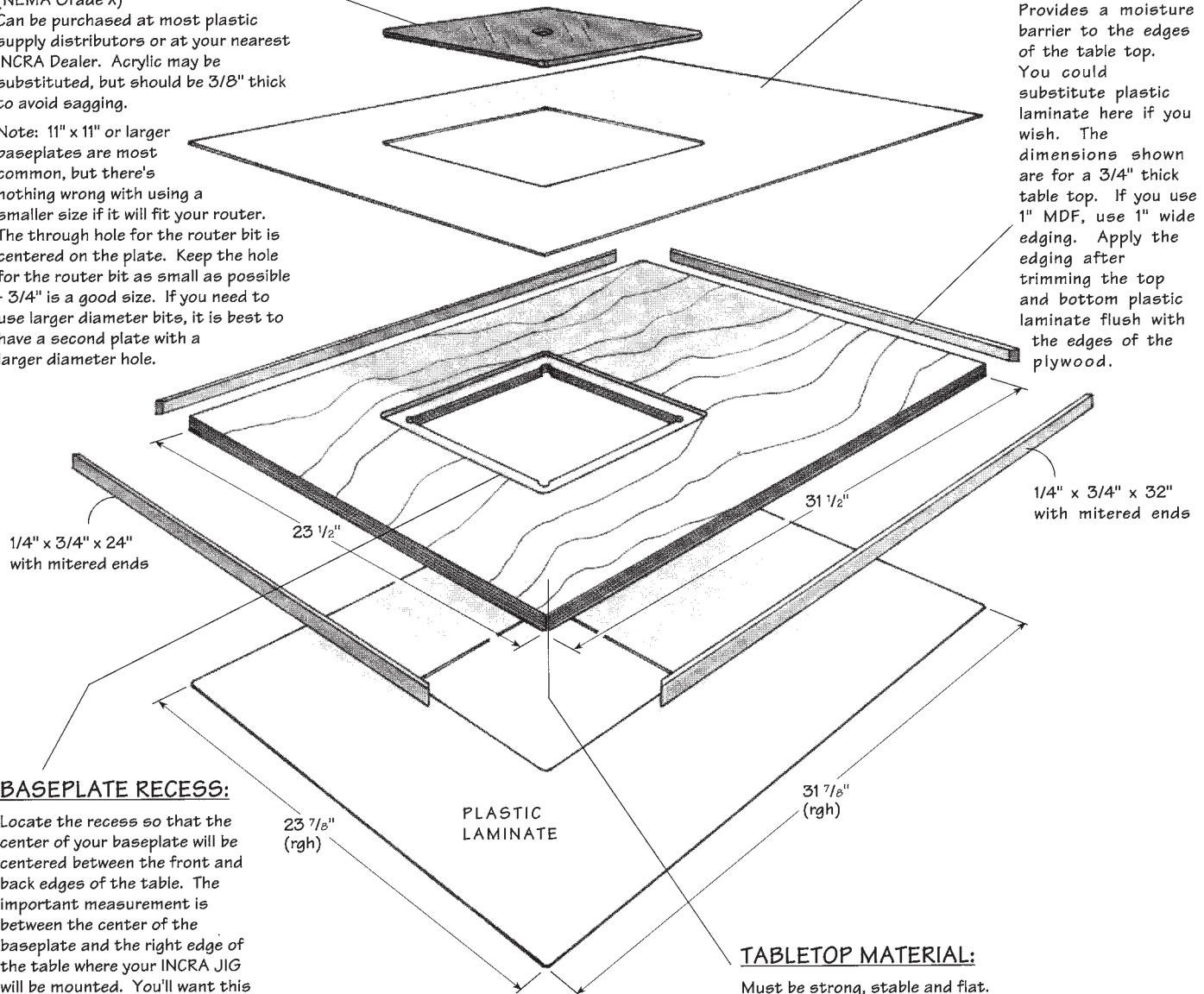

BASEPLATE RECESS:

Locate the recess so that the center of your baseplate will be centered between the front and back edges of the table. The important measurement is between the center of the baseplate and the right edge of the table where your INCRA JIG will be mounted. You'll want this distance to be 4" to 6" greater than your INCRA JIG's range. For example, if you have a 16" INCRA JIG PRO the distance between the center of your baseplate and the right edge of the table should be at least 20". Add 2" to this distance if you have an INCRA MIKE. Notice that the baseplate is located off center to the left.

TABLETOP MATERIAL:

Must be strong, stable and flat. This plan uses 3/4" Baltic birch plywood (actually 18mm), but you could substitute 1" MDF (medium density fiberboard).

Note: As with any hardwood plywood, Baltic birch isn't cheap. It is available in 5' x 5' and 4' x 8' sheets. If you go dutch with a fellow woodworker or two, the 5' x 5' will yield 3 table tops. The 4' x 8' sheet yields 6.

Routing the Baseplate Recess

If you have ever cut an inside hole or recess to accept an inlay, you know the potential problems... too tight, too loose, too deep or not deep enough. How do you get it right? The answer usually requires several hours of thought and preparation, sixty seconds of cutting, and twenty seconds of intense anxiety as you test fit the inlay. Questions about routing the baseplate recess in a router table are very common in the INCRA classes I teach, so here's a method I think you'll find both accurate and anxiety-proof.

Materials & Supplies

- 1 Router Table Top
(You should already have applied the plastic laminate top and bottom and the hardwood edging.)
- 2 Baseplate
- 3 Drill with 3/8" drill bit
- 4 3/4" x 12" x 18" plywood
- 5 Double sided tape
- 6 Router
- 7 1/2" to 3/4" diameter pattern bit with a maximum cutter length of 3/4"
- 8 Jigsaw

1 Locate the position on your table top for the baseplate recess as described in the paragraph headed "Baseplate Recess" on page 15. Place the baseplate in position on the router table top and outline with a pencil.

2 Remove the baseplate and draw a line 1" inside the pencil lines marked in Step 1. Now drill 3/8" diameter holes at the intersections of the inside lines. Fig. 1.

3 Cut five pieces from the 3/4" plywood. Four pieces need to be 2" wide x 12" long. One piece is cut to match the length and width of the area enclosed by the lines marked in Step 2. If your baseplate is 11" x 11" then the size of the last piece of plywood will be 9" x 9".

4 Place your baseplate back in position on your table top and using double-sided tape, attach

the (4) 2" x 12" pieces of plywood around the baseplate as shown in Fig. 2. Using a pencil through one of the holes drilled earlier, push the baseplate out of the frame of plywood.

5 Using double sided tape, attach the larger piece of plywood to your table top centered inside the plywood frame. Use the lines marked in Step 2 to help center the piece. Fig. 3. Now when you rout the grooves for the recess, this center piece not only keeps the router supported on both sides of the cut, but it also becomes a guide to widen the groove width to 1".

6 Install the pattern bit in your router and set the depth of cut to about 1/64" greater than the thickness of the plywood frame plus the thickness of the baseplate. See Fig. 4 on page 17. This means you will be routing a recess deeper than the thickness of your baseplate, but I have found it much

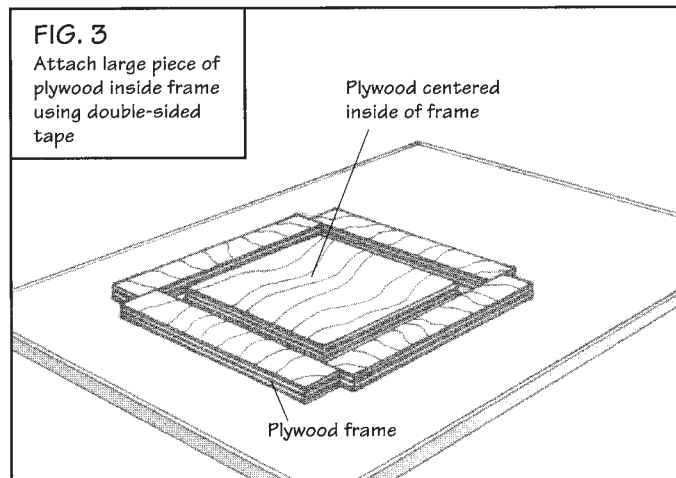
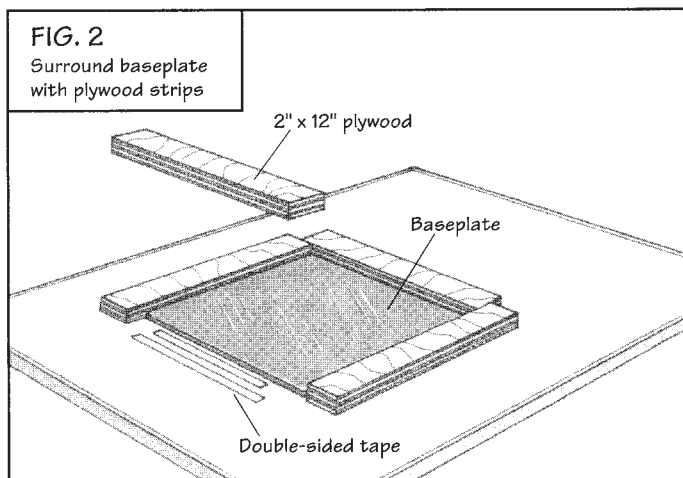
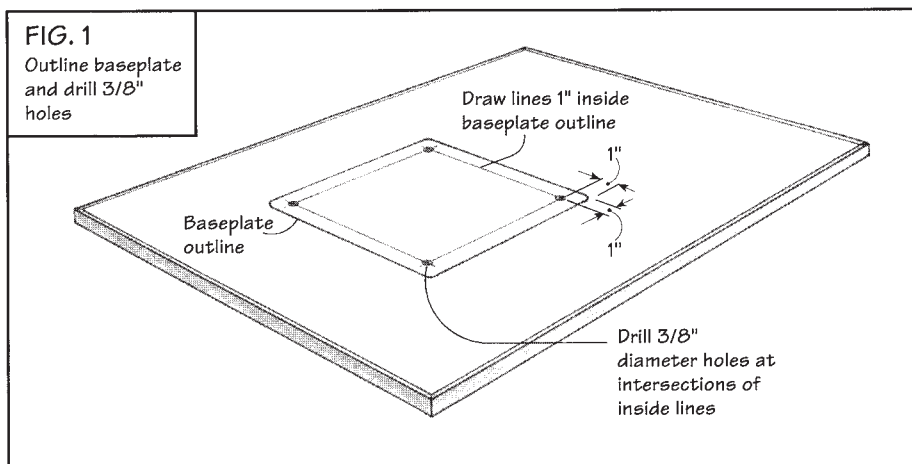

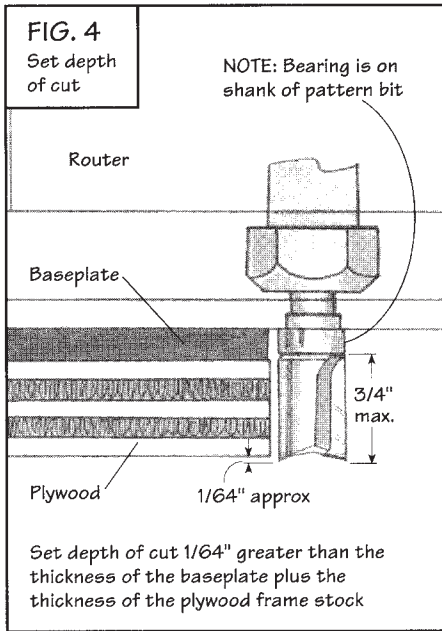

easier to make the baseplate flush with the table top by using masking tape as shim stock in a recess cut too deep than to try cutting a perfect recess.

7 Place the router on the table top with the bearing against the inside edge of the plywood frame and move the router clockwise around the frame to rout the initial groove. Then with the bearing against the larger piece of plywood, move the router counterclockwise to widen the groove cut on the first pass. Fig. 5.

8 You can now remove the plywood pieces and using a jigsaw, cut out the raised portion of the table top inside the groove. See Fig. 6.

9 You'll need to file or belt sand the corners of your baseplate to match the radius left by the pattern bit. As a finishing touch, file or sand a chamfer or radius on the bottom of your table around the opening. I've cut my knuckle on this spot many times when loosening a tight collet nut. Fig. 7.

TIP Before mounting your router to the baseplate you'll need to remove the existing sub-base on the router. Use the sub-base as a pattern to lay out the mounting hole locations on the baseplate. Be sure to think about access to your router's controls, spindle lock and collet when mounted in your table before drilling the holes.

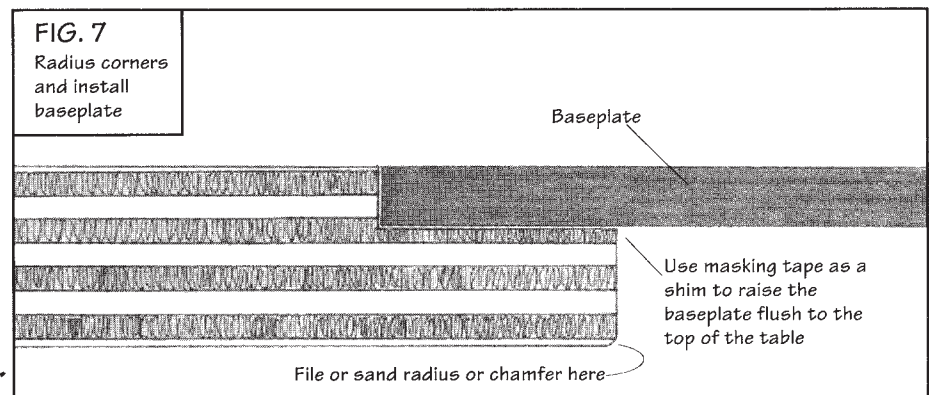
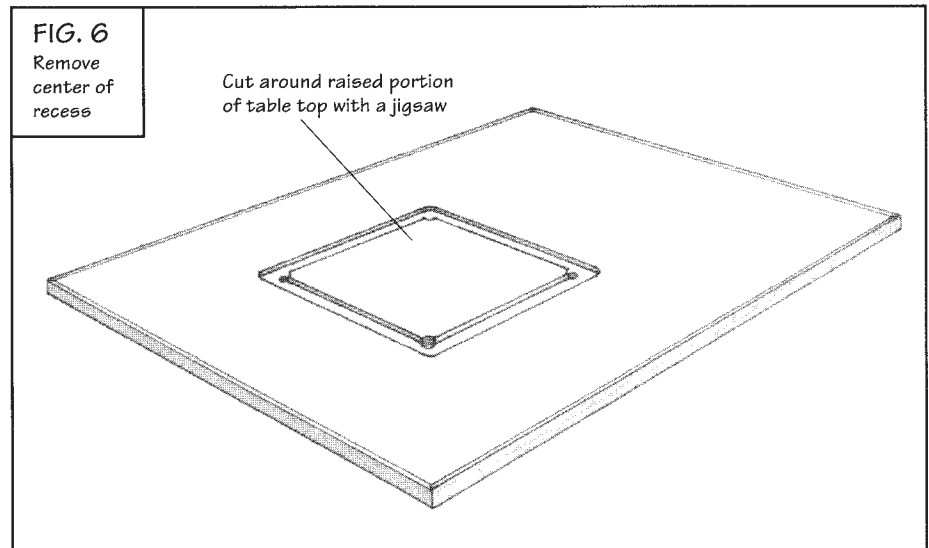
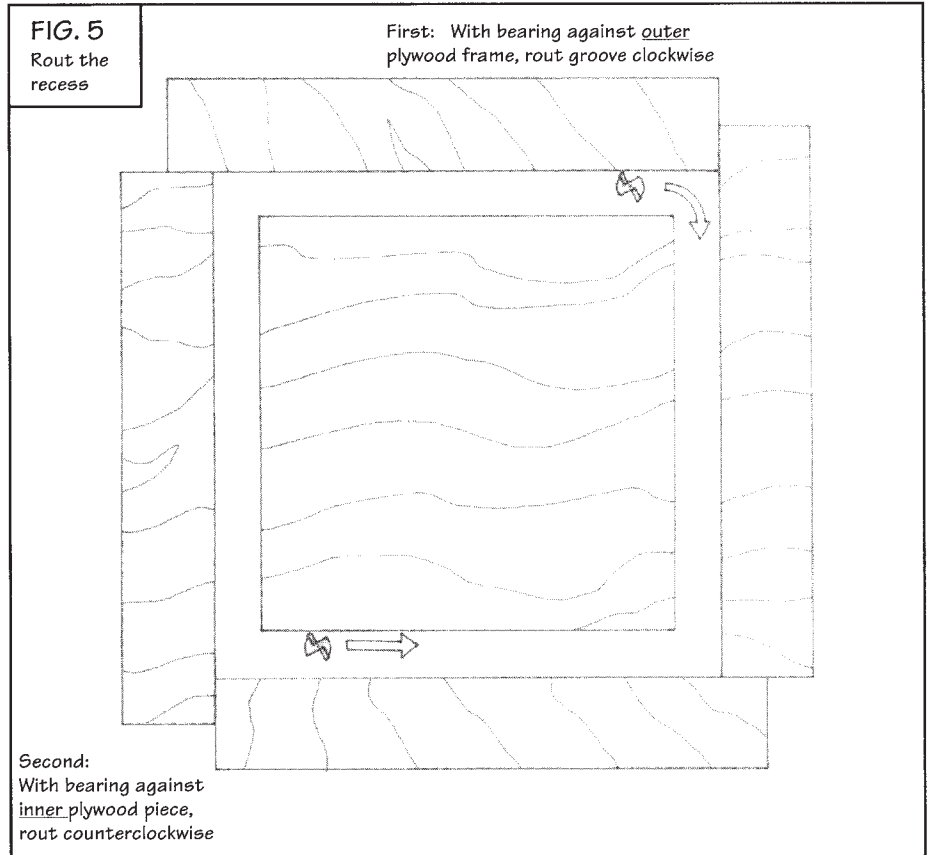

INCRA® JIG Base Clamping System

We've always shown the plywood mounting base for the INCRA JIG clamped to the router table using two C-clamps. The main advantage of using the C-clamps is that they provide instant mobility for your INCRA system should you decide to use it at your table saw or drill press. The problem I ran into with the C-clamps is probably unique. I have two router tables that I ship to various locations when conducting INCRA JIG workshops, and three more router tables in the shop. Since you can never have enough clamps in the shop, the last thing I want to do is tie up ten C-clamps holding INCRA JIGs down. The drawing at right represents a simple alternative requiring only a couple of carriage bolts, washers, and clamping knobs similar to the clamping knob used on the original INCRA JIG.

Note: (In order to use your INCRA JIG to set up for the cuts, you'll need to make a temporary base) Remember the $\frac{3}{4}$ " plywood base should be 8" wide and the length should match the front to back distance on your router table.

1 Install a $\frac{3}{8}$ " straight bit in your router table, set the depth of cut to $\frac{3}{8}$ " and the fence to blade distance at $2\frac{5}{16}$ ". Set infeed and outfeed stops as described on pages 32-33 using the dimensions shown in Fig. 1. After making the first cut, flip the board end for end with the same edge facing the outfeed stop and repeat the cut. Raise the depth of cut to $\frac{5}{8}$ " and repeat the cuts. Now raise the bit so that it will cut through the $\frac{3}{4}$ " plywood. **Caution:** Use a rubber soled push block and make sure the push block is about $3\frac{1}{2}$ " away from the fence.

2 Remove your INCRA JIG from the temporary base and attach to the new base. Fig. 1 shows the edge of the base that faces the cutter. To locate the position for drilling the $\frac{3}{8}$ " holes in your router table, open the INCRA JIG to its fullest extension and position the front face of the fence about $\frac{1}{2}$ " beyond the center of your router collet. Mark the drill centers in the middle of the $\frac{3}{8}$ " wide x 4" long slot on each end of the base. See Fig. 2. Drill the holes then press in the carriage bolts from the bottom. When you clamp the base down using the two clamping knobs the carriage bolts will seat themselves.

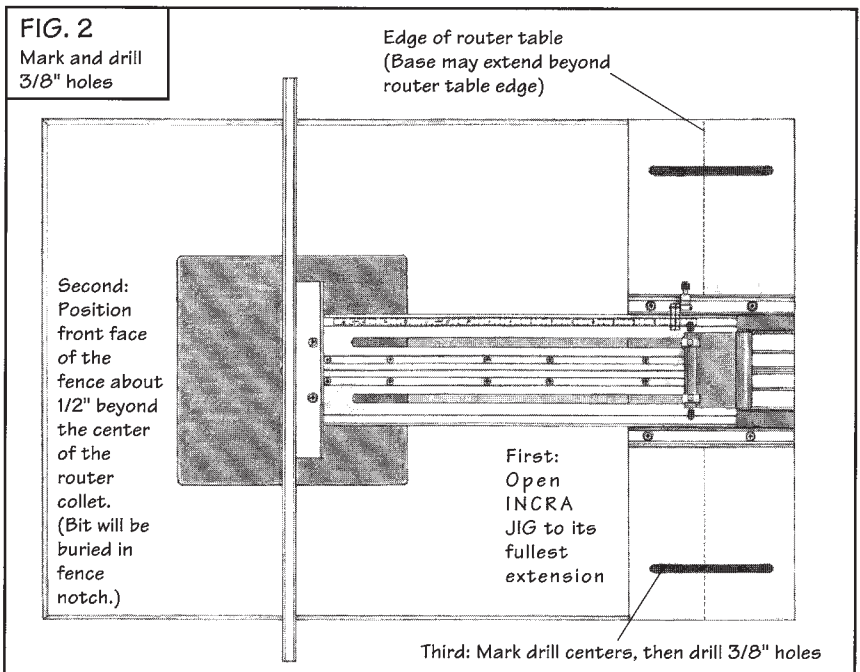
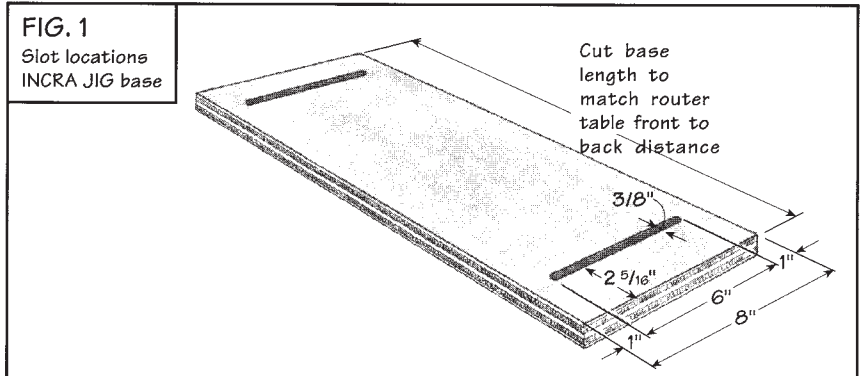
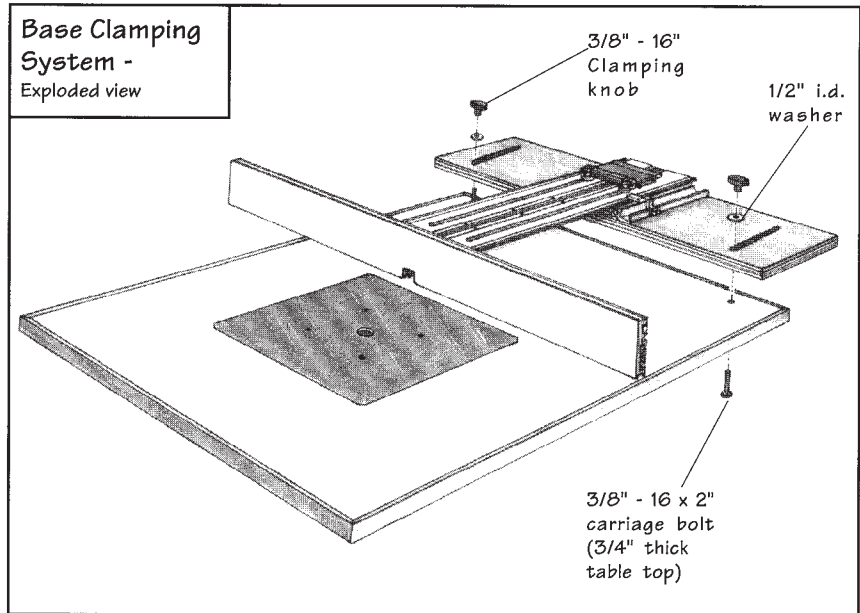

III

TECHNIQUES

Beginning with a discussion of the two most important fence alignment processes, “centering” and “zeroing”, the sections to follow address a variety of useful techniques. You’ll find charts to help you with selecting and understanding the relationship between stock thickness, router bits and templates. There are accurate formulas for use in determining stock length when producing various corner joinery. Box making techniques include: how to line boxes with leather, adding compartments and lift out trays, and a hinge mortising template for the INCRA wooden hinge. You’ll also find plans for a vertical holding jig which can be used at your table saw for making raised panel cuts. The plans include two auxiliary face plates for cutting tenons and splined miters.

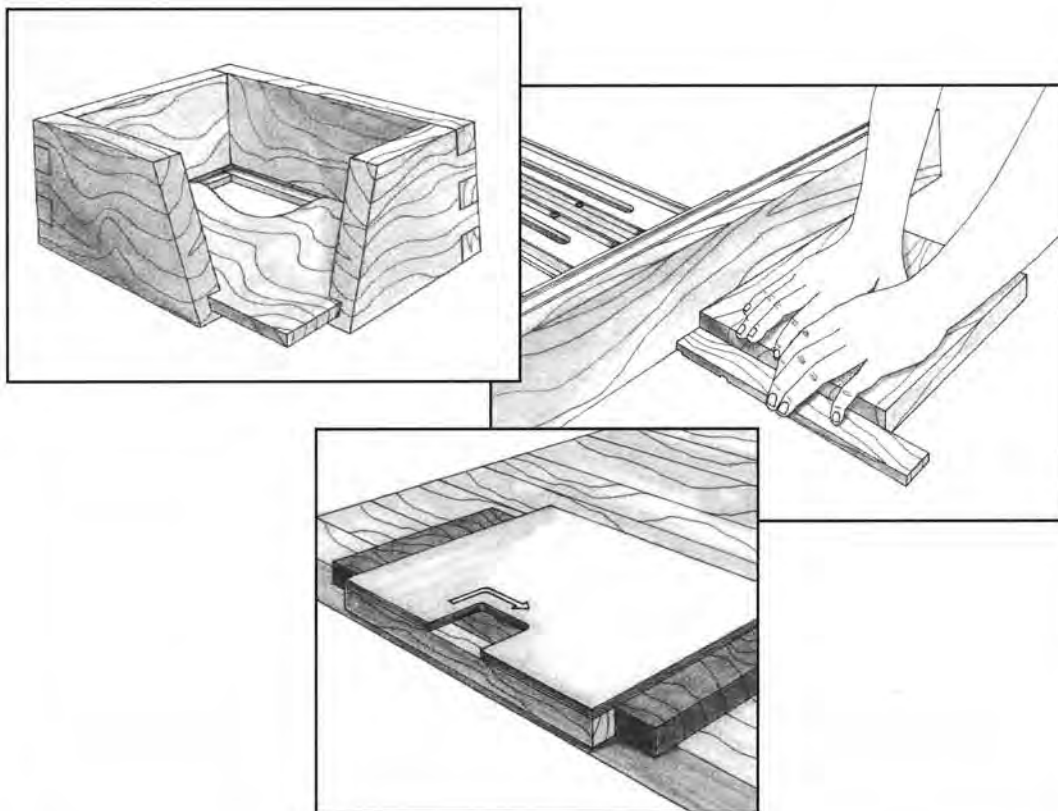

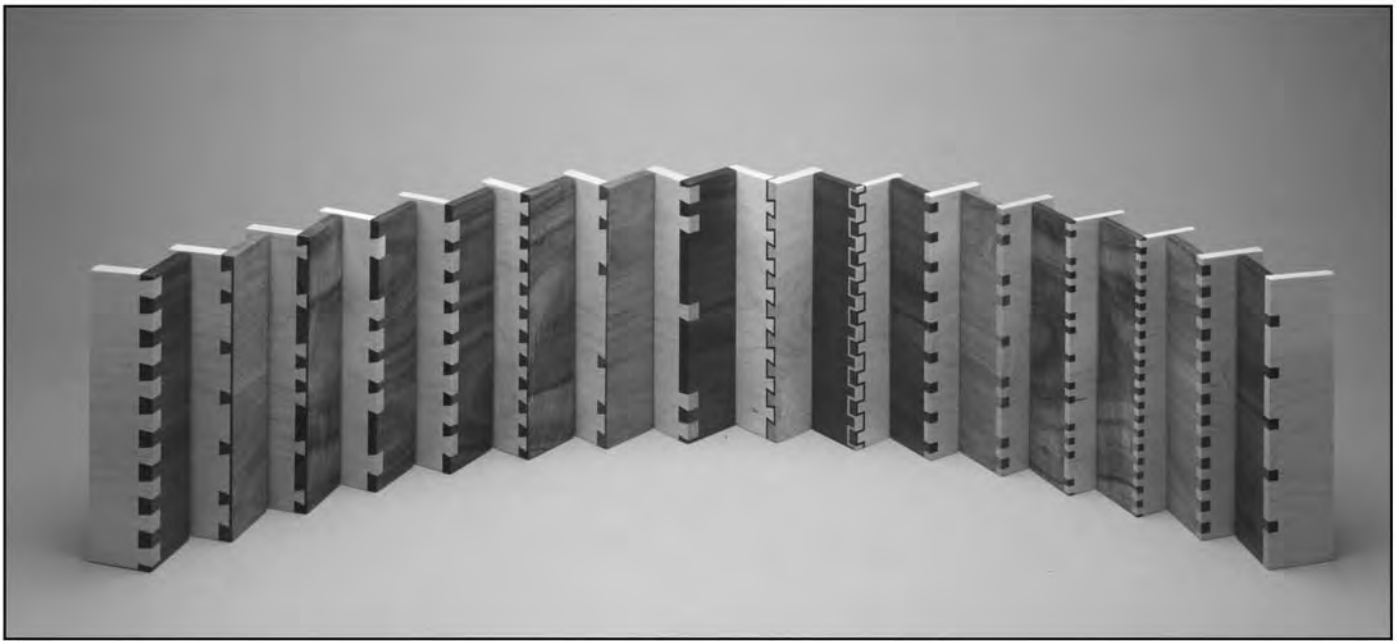

Centering and Zeroing

Centering

Certainly one of the most important steps in producing any fine joinery is laying out the joint symmetrically. A symmetrical joint will always have pins of equal width on both ends, and one of the two pieces that make up the joint will always have a cut in the exact center of the stock width. See Fig. 1. Placing this "center cut" in the center of your stock width is where the process known as centering comes in.

Centering is a method by which a groove or dado can be placed in the center of any width of stock to within a few thousandths of an inch. Once this center position is located, the INCRA positioning racks along with the INCRA Templates or the $\frac{1}{32}$ " scale are used to ensure that all subsequent cuts are placed with respect to the center of the stock width. The method requires no mathematics and with a little practice, it can be done without any measuring devices. When used in conjunction with INCRA Templates, centering will allow you to produce perfectly symmetrical joinery. The technique lends itself to many applications in this book, from drilling a perfectly centered hole pattern on the dominoes shown on pages 98-105, to cutting a series of centered stopped grooves on the trivet shown on pages 88-91. Let's take a step-by-step look at centering.

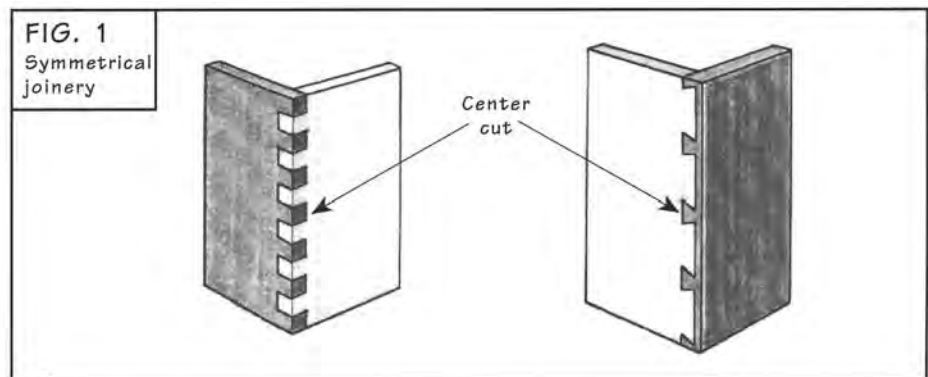

1 Install router bit and set depth of cut

For each centering operation, begin by installing the router bit called for by the plans.

For any dovetail joint, set the depth of cut as described on pages 2-3 of the Master Reference Guide. Make the test cuts as described in step 2 then adjust as necessary to achieve the desired fit.

Each of the projects in this book requiring joinery will specify the template necessary to set the depth of cut. For non-joinery applications, set the depth of cut as specified by the plans. Of course, not all centering operations are performed at the router table as you will see in the domino plans, shown on pages 98-105, where you will be centering on both the domino's length and width using a drill bit at your drill press.

2 Choose "center cut" and install template

For your convenience, we have pre-selected a "center cut" for each of the centering applications in this book requiring a template or the $\frac{1}{32}$ " scale. You will find this suggested "center cut" described in the set of plans for the project you have chosen. Install the template in your INCRA JIG, then slide the INCRA JIG to position the "center cut" on the template directly under the hairline cursor. Lock the clamp in place. (For the original 8" INCRA JIG, position the end of the top half directly over the "center cut" and tighten the clamping knob.) Once the INCRA JIG is set to the suggested "center cut", the cam clamp or clamping knob will remain locked throughout the entire centering process.

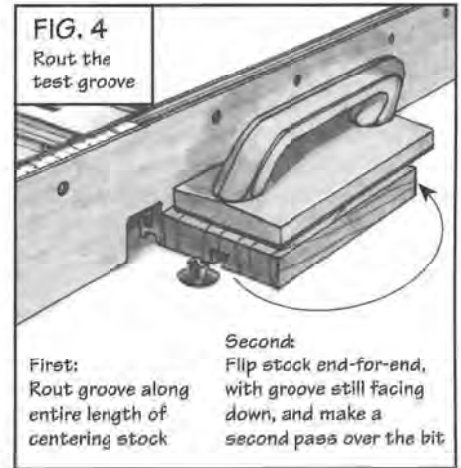
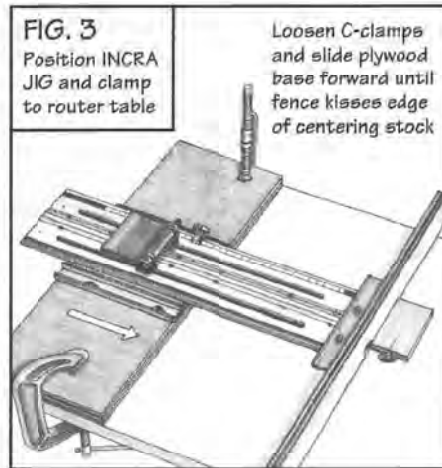
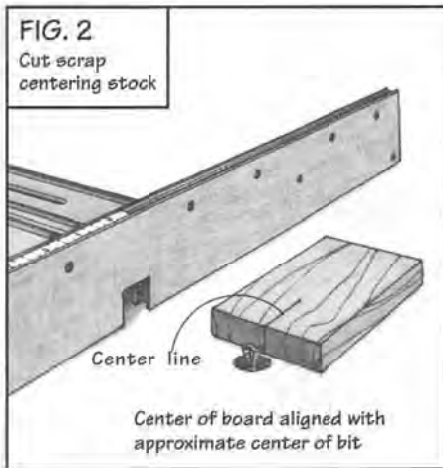

3 Cut a piece of scrap centering stock

Cut a piece of scrap $3/4$ " stock to exactly the same width as the stock you wish to center on. For instance, if you want to produce a centered corner joint on a $2\ 5/8$ " wide board, you'll need a scrap of $3/4$ " stock that is also $2\ 5/8$ " wide. Cut the length of the scrap to a minimum of 5" long. If the piece you are centering on is wider than 5", cut the scrap stock's length to match the width. Now mark the center of the width on one end of the scrap stock and place the board face down on the router table. Align the mark on the board with the approximate center of the router bit. See Fig. 2.

4 Position INCRA JIG and clamp to router table

Loosen the C-clamps that secure the plywood base to your router table and advance the entire INCRA unit (plywood base and INCRA JIG) to position the fence adjacent to the centering stock on the router table. See

Fig. 3. Make sure the center mark on the board is still aligned with the approximate center of the bit. Tighten the C-clamps to secure the plywood base to the table.

Remember: The INCRA JIG should still be locked to a template reading directly over the pre-selected center cut.

5 Rout the test groove

Turn on the router and, with a good rubber soled push block, cut a groove along the entire length of the centering stock. See Fig. 4. Now turn the stock end-for-end with the groove still face down, and make a second pass over the bit. This second pass should widen the groove slightly. Make sure you have turned the stock end-for-end (which places the center mark at the back of the board) before making the second pass.

6 Adjust INCRA fence position to establish a perfect center

With the router unplugged, position the

bit at its widest cut angle as viewed from the infeed side of the router table. Place the centering stock against the fence with the bit just inside the test groove cut in the previous step. When viewed from the infeed side, there should be a small gap between the edge of the bit and one side of the groove. See Fig. 5. The gap might be on the left or the right side of the bit, depending on the initial position of the INCRA JIG plywood base.

To find the perfect center, the fence position must be adjusted so that the bit is located in the middle of the test groove. To do this, loosen one of the two C-clamps that secure the INCRA JIG plywood base to your table. With the INCRA JIG still locked in to the pre-selected "center cut", tap the plywood base either toward or away from the bit so that, with the centering stock against the fence, the bit is centered in the test groove. See Fig. 6. Now tighten the C-clamp. You have now positioned your INCRA JIG so that the selected "center cut" will be placed in the exact center of the stock width you are using.

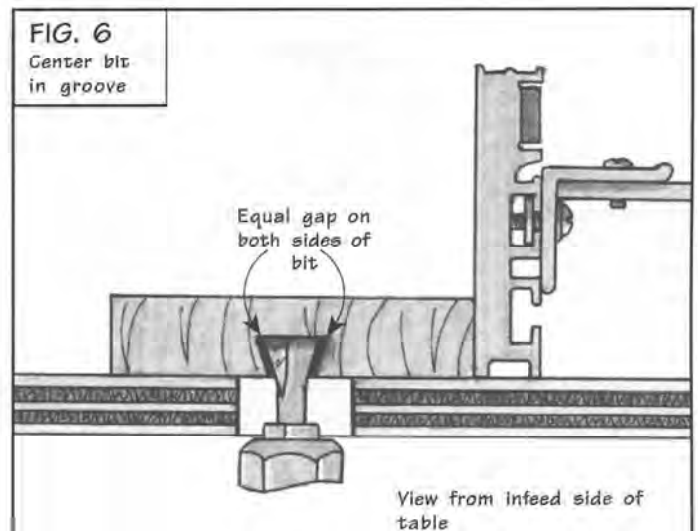
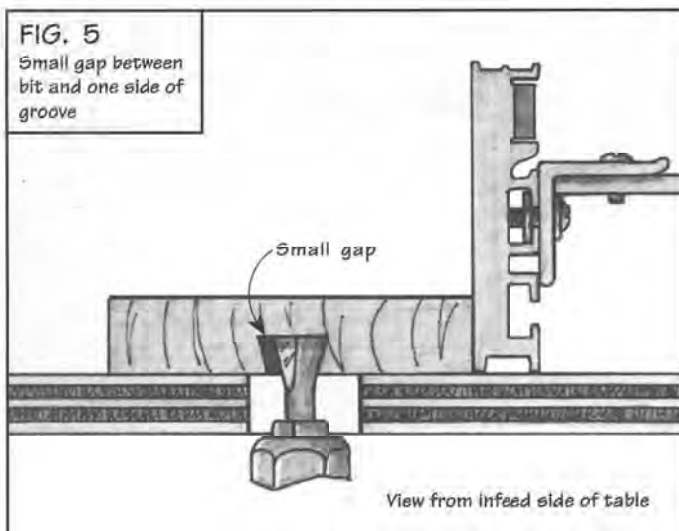

Centering using the INCRA Mike™

If you own the INCRA Mike micro positioner, you can usually avoid the tapping procedure by simply "dialing in" the exact amount of fence adjustment needed to center the bit perfectly in the groove. In fact, I have found that if I install the "center cut" on the template under the hairline cursor after the centering process is complete, the plywood base on my INCRA JIG Pro does not have to be moved at all. For instance, if in Fig. 7 the gap between the bit and the edge of the groove is about $1/8"$, I release the cam clamp to move the fence back $1/16"$, then lock the cam clamp. Any remaining fine tuning of the fence position can be done using the INCRA Mike. See Fig. 8. Once the center position is found, I install the template, sliding it in the scale slot until the selected "center cut" is positioned directly under the hairline cursor.



With the INCRA Mike micro positioner there's no need to tap the base. Simply dial in the exact amount needed to center the bit in the groove.

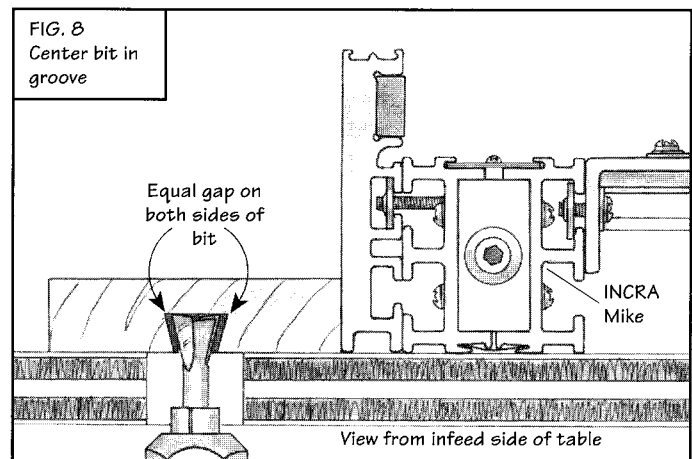
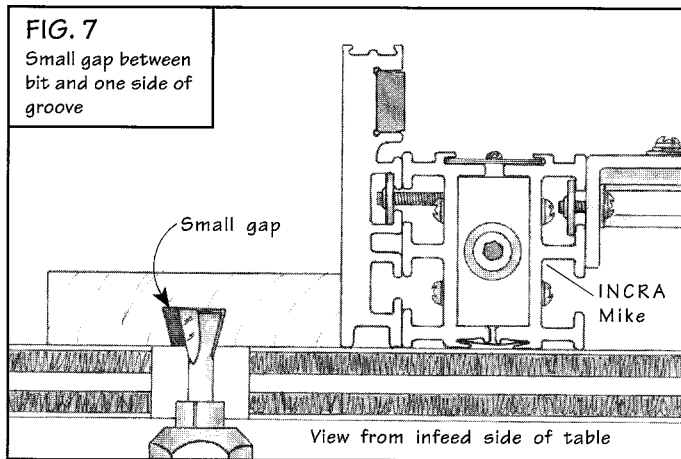

Zeroing

Several of the projects in this book require that you first "zero" your fence to the edge of a bit before making a series of cuts. To set the fence to bit distance equal to zero, open your INCRA JIG to a scale reading of 0" and lock the cam clamp or clamping knob in place. With the router turned off and unplugged, sight down the fence as shown in Fig. 9 and tap the plywood base to move the fence toward the bit. With each tap, the gap between the fence and the cutting wing of the bit will get smaller. Continue tapping carefully until one last tap causes the gap to disappear. When this happens, the bit will be "zero" distance from the fence. Check to make sure that the bit is approximately centered in the fence notch, then clamp the plywood base to your table with two C-clamps. You have now positioned your fence so that all of your cuts will be made relative to the edge of your stock. (Example: By setting your INCRA JIG to a scale reading of 1" and making a cut, you will produce a groove 1" from the edge of your stock.)

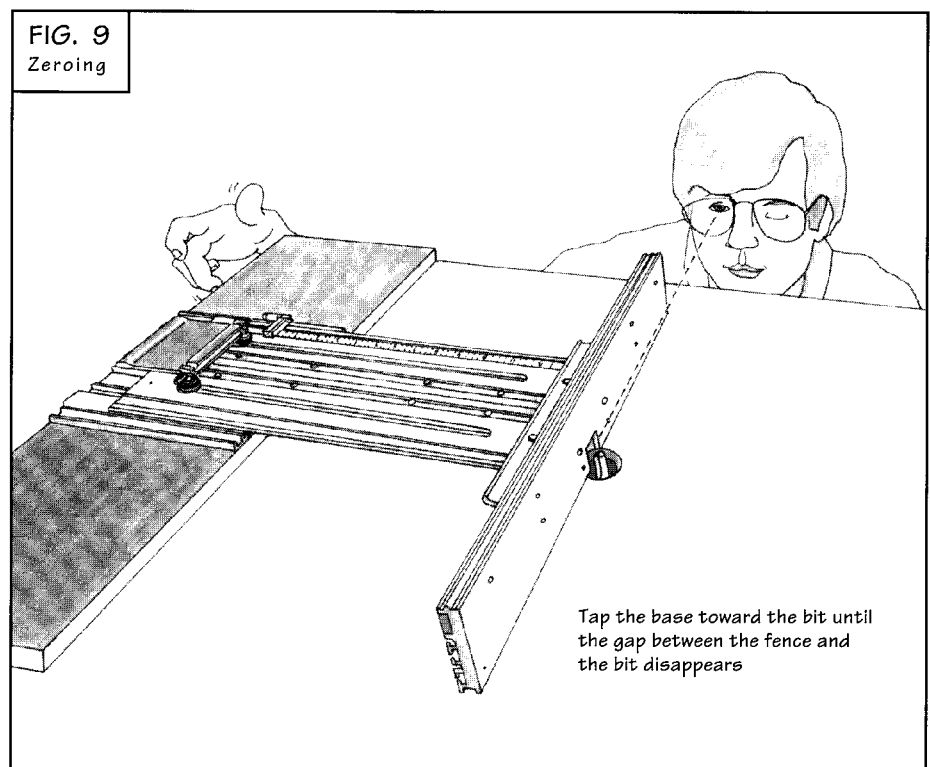

Stock Thickness, Router Bit and Template Selection

Two of the most asked questions about using INCRA JIG for joinery are, "What stock thickness should I use with this template?" and "What template should I use for this thickness of stock?" These are tough questions. Not because I don't have an answer - I do - but it is only my opinion, and not the only answer.

For instance, someone asks, "What template do I use to cut half-blind dovetails in $\frac{3}{8}$ " stock?" Well, there are four different bits which could be used for the task, one of which I think would be too small. Of the remaining three dovetail bits, there are 15 different templates to choose from and each of these templates produces a different pattern. I would probably inquire as to which of the three router bits the woodworker owns to narrow the field and then base my answer on the width of the stock he wanted to join. See what I mean?

You'll notice that in answering the question I began by determining which router bits would do the job, then based my final decision on which pattern (template) would look the best on the stock width. On the next page, you'll find some charts to help with router bit and template selection, but first let's review the basic relationship between specific joinery and stock thickness.

Box Joints

The thickness of the stock must be equal to or slightly less than the depth of cut. Keep in mind, however, that you should never cut any deeper than the diameter of your bit in any single pass. Therefore, in order to cut a $\frac{3}{4}$ " deep groove with a $\frac{3}{8}$ " straight bit, it would be necessary to make two or more passes, raising the bit after each cut until the desired depth is achieved.

Half-Blind Dovetails

The thickness of the stock must be at least $\frac{1}{16}$ " greater than the depth of cut.

Through Dovetails

The thickness of the stock must be equal to or slightly less than the depth of cut.

With these ground rules in mind, the charts on page 26 offer my suggestions for stock thickness and template options for each of the router bits for which INCRA templates are produced. After determining the router bit you will use, look at the full-sized plans in your template books to select the pattern that looks the best.

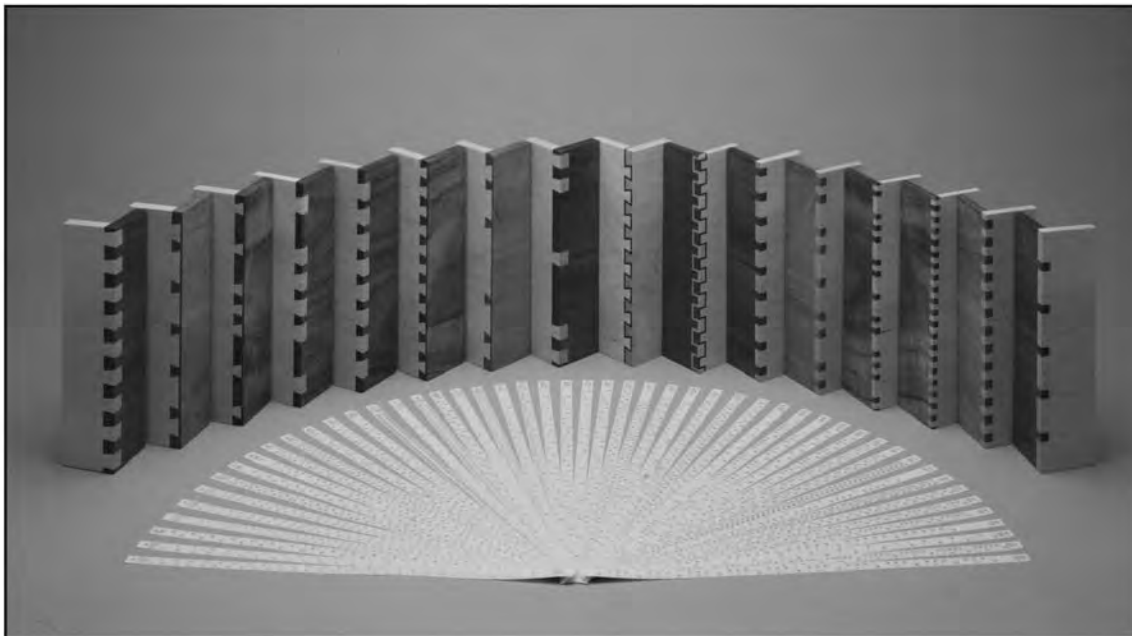

Genuine INCRA Templates can be used with a wide variety of router bits and stock thicknesses to produce many varied and unique joints, like the ones shown here.

Box Joints

ROUTER BIT	STOCK THICKNESS	TEMPLATE OPTIONS
1/8" Straight	1/8"	BOXA
3/16" Straight	3/16"	BOXB, BOXC
1/4" Straight	1/4"	BOX4, BOX5, BOXD BOXE, BOXF
3/8" Straight	3/8"	BOX1, BOX2, BOX3 BOXG, BOXH, BOXI DDBOX1

Note: The numerical templates (DOV1, DOV2, etc.) are found in the Official INCRA JIG Handbook and Templates. The alphabetical templates (DOVA, DOVB, etc.) are contained in the INCRA Master Template Library. The INCRA Double-Double Box Joint templates (DDBOX1) are found in The Complete INCRA JIG Video and in the INCRA Master Template Library.

Dovetail Joints

ROUTER BIT	STOCK THICKNESS		TEMPLATE OPTIONS
	Half-blind Dovetails,** INCRA Double Dovetail, INCRA Cornerpost Double Dovetail	Through Dovetail***	
1/4"-7.5° Dovetail	3/8"	1/4"	DOV8, DOVA, DOVB, DOVC DOVD, IDDA*
5/16"-9° Dovetail	1/4" to 3/8"	3/16"	DOV7, DOVE, DOVF
3/8"-9° Dovetail	3/8"	1/4"	DOV5, DOV6, DOVG, DOVH, DOVI, IDD2*, IDDB*, IDDC*
1/2"-14° Dovetail	3/8" to 1/2"	1/4"	DOV1, DOV2, DOV3, DOV4, DOVJ, DOVK, DOVL, DOVM, IDD1*, IDDD*, IDDE*
1/2"-14° Dovetail	1/2"	3/8"	DOVN, DOVO, DOVP, DOVQ
17/32"-14° Dovetail	1/2"	3/8"	DOV1, DOV2, DOV3, DOV4, DOVJ, DOVK, DOVL, DOVM, IDD1*, IDDD*, IDDE*
5/8"-7° Dovetail	3/4"	1/2"	DOVR, IDDF*
5/8"-7° Dovetail	1"	3/4"	DOV10, DOVS
3/4"-7° Dovetail	3/4"	1/2"	DOVT
3/4"-7° Dovetail	1"	3/4"	DOV9, DOVU

* INCRA Double Dovetail Template - for use in making the INCRA Double Dovetail or the INCRA Cornerpost Double Dovetail.

** Remember, half-blind dovetails, including the INCRA Double Dovetail and the INCRA Cornerpost Double Dovetail, can be cut in any stock thickness at least 1/16" greater than the depth of cut. Using the dimension given will yield pleasing dovetail proportions, but you are by no means limited to these recommendations.

*** The stock thicknesses shown for through dovetails are approximate. It is necessary to first set the depth of cut for your dovetail bit as described on pages 2 - 3 of the Master Reference Guide. Once the depth of cut is set, use a stock thickness that is equal to or slightly less than your depth of cut.

Boxes Made to Order - Calculating Stock Length for Joinery

As you begin your exploration into the strength and beauty of joinery, no doubt the simplest and most economical method is to start with small boxes. Don't worry about the dimensions of the box. Concentrate instead on the joinery technique itself. After the joinery is complete, make a bottom and top to fit the box. By working with random stock lengths (4 boards of equal length or 2 boards of one length and 2 of another), the emphasis will be on the joinery, while the finished box, no matter what size, will be useful.

Eventually however you will want to produce a box, drawer, or case with a specific inside or outside dimension. For instance, you've made a cabinet and want to make drawers to fit the openings, or you want to make a box inside a box inside a box. In the formulas to follow you'll see that the basic joinery (box joints, half-blind dovetails and through dovetails) follows standardized rules. Whether hand cutting or machine cutting your joinery, these rules remain unchanged.

The Variables

Whenever determining the length of the individual pieces that go into the construction of a box, you'll need to know three things: the stock thickness, the depth of cut for your router bit, and, of course, the desired outside or inside dimensions of the box to be built. The chart on page 26 will help you with router bit and stock thickness selection.

Install the router bit in your router table and set the depth of cut. For box joints the depth of cut should be set equal to the thickness of your stock for ease in sizing. For half-blind and through dovetails, you'll need to set the depth of cut as described on pages 21-23 of *The Official INCRA JIG Handbook and Templates*. Two methods are described for setting depth of cut, the sliding dovetail method and the right angle fixture method. I prefer the right angle fixture method. Whichever method you use, the important thing to remember is to always use the equally spaced dovetail template to set the depth of cut. Once the depth of cut is set, you can change to any template which has the same router bit and depth of cut requirements.

Once you know your stock thickness and depth of cut, you can design your box and its dimensions one of two ways - from the outside in or from the inside out. If you want to make a drawer to fit an opening in a cabinet, you'll want to start with the outside dimensions. But if you want to make a snug fitting box to hold a particular object like that old Monopoly® game board and pieces, you'll want to start with inside dimensions. For each of the joinery types to follow you'll find the formulas to work with either the desired outside or inside measurement.



The Playing Card Box shown here is an example of a box whose size must be determined by the inside dimensions.

Box Joints and Through Dovetails

Each of the opposing pair of sides is calculated using the same formula:

Side length = Outside dimension

OR

Inside dimension + (2 x depth of cut)

Note: In order for these formulas to work accurately it is important that the thickness of your stock be equal to the depth of cut you have set for your router bit.

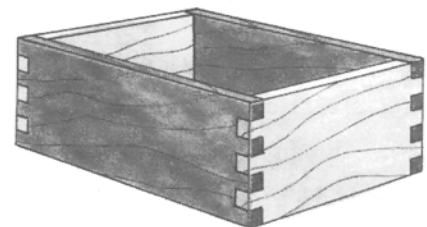

Box Joints

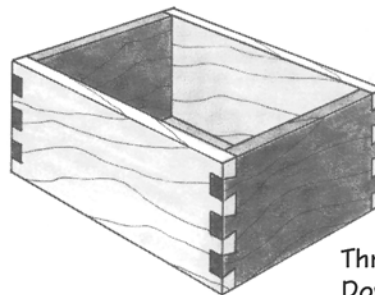

Through
Dovetails

Half-blind Dovetails

The pin and tail section lengths are each calculated a little differently.

Pin length = Outside dimension

OR

Inside dimension + (2 x stock thickness)

Tail length = Outside dimension - (2 x stock thickness)
+ (2 x depth of cut)

OR

Inside dimension + (2 x depth of cut)

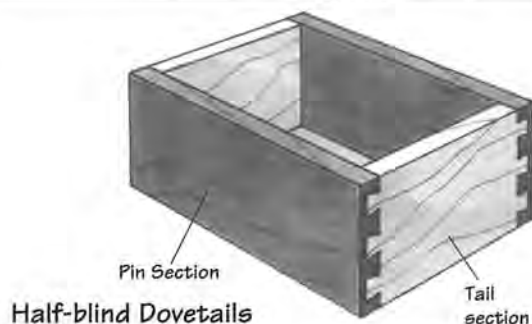

INCRA® Double Joinery

INCRA double joinery requires certain modifications to the basic formulas above to account for the extra piece of wood (trim section) added to the joint. What you are determining through these formulas is the length of the sides before the trim section and/or cornerpost are added.

INCRA® Double Dovetail™

An INCRA Double Dovetail is, in essence, a half-blind dovetail. As such, the pin and tail section lengths are each calculated a little differently.

Pin length = Outside dimension

OR

Inside dimension + (2 x stock thickness)

Tail length = Outside dimension - (2 x stock thickness) - $\frac{3}{16}$ "*
+ (2 x depth of cut)

OR

Inside dimension - $\frac{5}{16}$ "* + (2 x depth of cut)

* If using template IDDF, which requires a $\frac{3}{8}$ "-7° dovetail bit, change $\frac{3}{16}$ " to $\frac{1}{4}$ ".

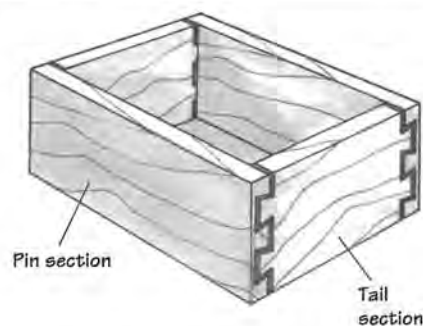

INCRA® Cornerpost Dovetail™ and Cornerpost Eagletail™

Each of the opposing pair of sides is calculated using the same formula:

Side length = Outside dimension - (2 x stock thickness)
+ (2 x depth of cut)

OR

Inside dimension + (2 x depth of cut)

INCRA
Cornerpost
Eagletail

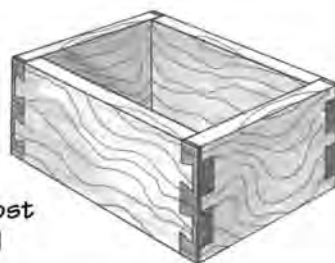

INCRA
Cornerpost
Dovetail

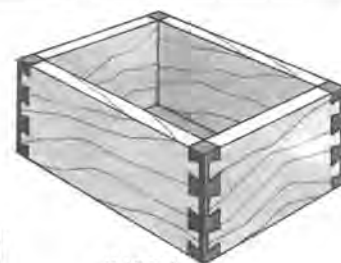

INCRA® Cornerpost Double Dovetail™

Each of the opposing pair of sides is calculated using the same formula:

$$\text{Side length} = \text{Outside dimension} - (2 \times \text{stock thickness}) - \frac{3}{16}''^* \\ + (2 \times \text{depth of cut})$$

OR

$$\text{Inside dimension} - \frac{3}{16}''^* + (2 \times \text{depth of cut})$$

* If using template IDDF which requires a $\frac{5}{8}''$ 7° dovetail bit, change $\frac{3}{16}''$ to $\frac{1}{4}''$.

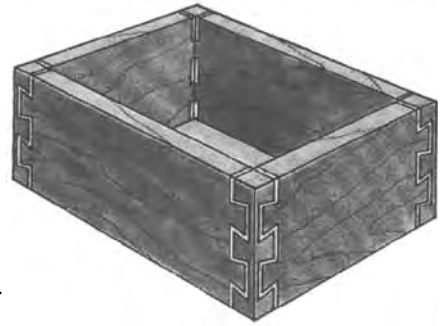

INCRA Cornerpost Double Dovetail

INCRA® Double-Double Box Joint™ and Double-Double Through Dovetail™

Each of the opposing pair of sides is calculated using the same formula:

$$\text{Side length} = \text{Outside dimension} - \frac{3}{16}'' \\ \text{OR}$$

$$\text{Inside dimension} - \frac{3}{16}'' + (2 \times \text{depth of cut})$$

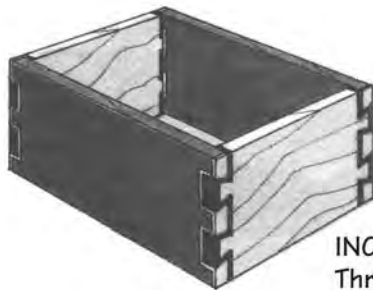

INCRA Double-Double
Through Dovetail

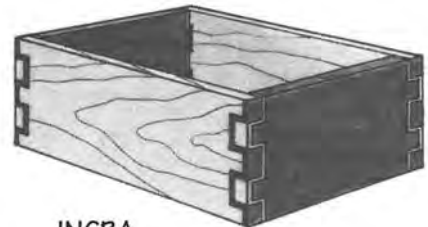

INCRA
Double-Double Box Joint

Installing Box Bottoms - Stopped Mortises

Using two INCRA Stops in conjunction with your INCRA JIG and INCRA Fence System can produce some very interesting results. Just look at the **Train Whistle** on pages 74-77 or the Trivets shown on pages 88-91. Each of these projects requires a series of accurately stopped grooves or mortises and, although installing a box bottom generally only requires a single stopped groove in two of the sides, all of these projects share a common technique for setting the infeed and outfeed INCRA Stop positions.

Pages 8 and 9 of your INCRA Fence System owner's manual cover several different methods for setting your stop positions for a variety of cutting operations. I have found that a slight modification to one of these methods makes the technique quite easy to remember. In fact, I use this technique for every INCRA Stop setup in my shop. Before we get too far, however, let's discuss some box bottom basics.

There are several ways to install a box bottom. You could simply glue a panel to the bottom edge of the four sides, Fig. 1, or rabbet the bottom panel so that it fits into the opening in the bottom panel of the box, Fig. 2. Quite often you will see the bottom of the box sides rabbeted to accept the bottom panel, Fig. 3. All of these methods will work well if the bottom panel is from a dimensionally stable material such as plywood. If you prefer to use hardwood, these methods all fall short in that they don't allow for wood movement in the panel.

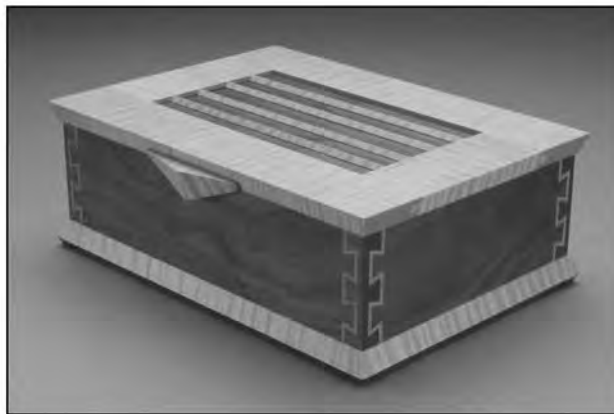

Like the other boxes in this book, the **Trinket Box** and **Jewelry Box** shown here have a "captured" bottom panel to allow for wood movement.

FIG. 1

Panel glued to bottom edge of box sides

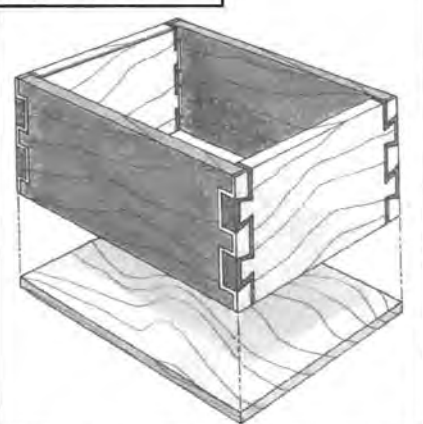

FIG. 2

Rabbeted bottom

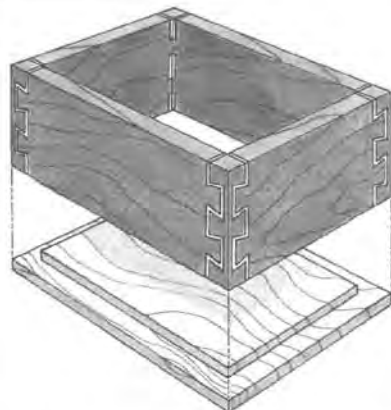
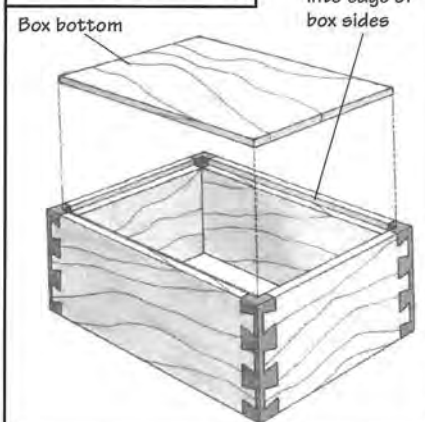

FIG. 3

Panel fits into rabbets cut into edge of box sides



The "Captured" Bottom Panel

FIG. 4
Cut away view

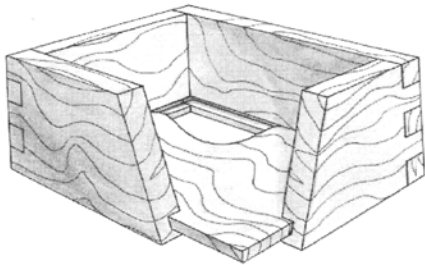

Bottom panel is "captured" in grooves cut in box sides

Probably the best method is to cut grooves into the sides of the box to accept the bottom panel, Fig. 4. Once the box is glued up, the bottom becomes "captured" within these grooves. This method has two advantages: First, the grooves and the panel can be cut to allow for wood movement. This means you can use a solid wood bottom if you wish, instead of plywood. Second, there are no exposed glue joints between the sides of the box and the box bottom.

Stopped Grooves, or Not?

For through dovetails and box joints two of the sides will always require stopped grooves, and depending on where the grooves are located, all four sides may need stopped cuts. By locating the grooves for the bottom panel so that they are placed within one of the grooves cut in the joinery, only two of the sides will need stopped cuts, Fig. 5. If you cannot locate the grooves for the bottom to coincide with the joinery grooves on two of the sides, then it will be necessary to stop the cuts on all four sides, Fig. 5a.

For half-blind dovetails the pin section will always require stopped grooves unless the grooves are located to coincide with the grooves cut in the joinery, Figs. 6 and 6a. The tail sections do not require stopped cuts.

Note: If you are placing the grooves for your bottom panel to coincide with grooves cut for the joinery (Figs. 5 and 6) it is important that the diameter of the grooving bit be less than the narrowest portion of the joinery groove and that the depth of cut of the grooving bit does not exceed the depth of cut used in cutting the joinery.

FIG. 5
Box joints and through dovetails

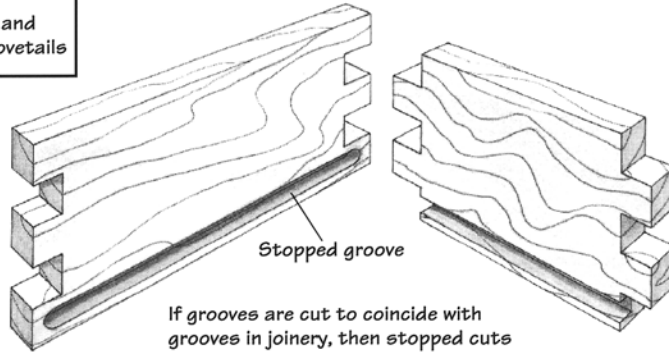

If grooves are cut to coincide with grooves in joinery, then stopped cuts are only required on two sides

FIG. 5a

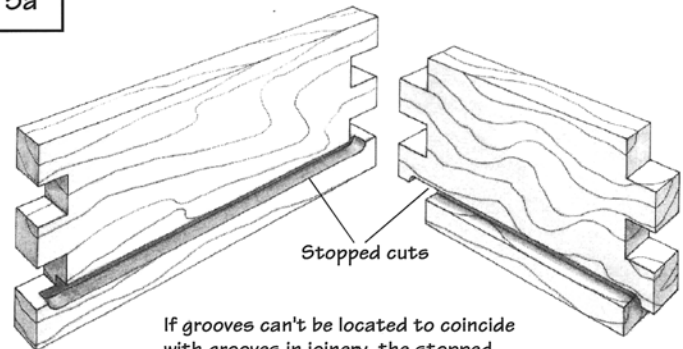

If grooves can't be located to coincide with grooves in joinery, the stopped cuts must be made on all four sides

FIG. 6
Half-blind dovetails

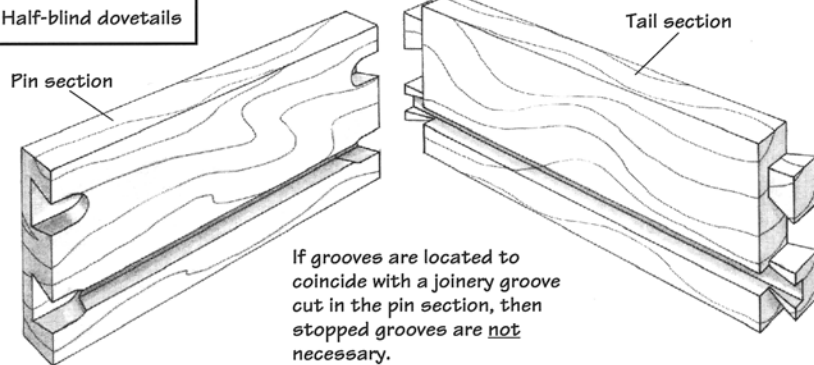

If grooves are located to coincide with a joinery groove cut in the pin section, then stopped grooves are not necessary.

FIG 6a

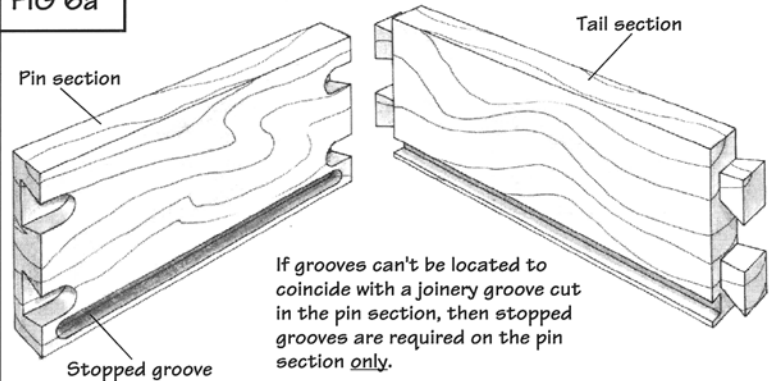

If grooves can't be located to coincide with a joinery groove cut in the pin section, then stopped grooves are required on the pin section only.

The Method

Whenever you wish to set up infeed and outfeed stops to cut a stopped groove or mortise you'll first want to determine three dimensions:

- (A) Distance from front end of board to the beginning of the groove
- (B) Distance from the back end of board to the end of the groove
- (C) Length of the board

For all of the boxes in this book (A) and (B) are $\frac{3}{16}$ ". In fact, I also set the $\frac{1}{4}$ " straight bit to a $\frac{3}{16}$ " depth of cut and the fence to bit distance is set at $\frac{3}{16}$ ". This grouping of $\frac{3}{16}$ " measurements works well for smaller boxes and makes the setup quite easy to recall when needed. If your box dimensions exceed 8" x 10", you'll need to increase the depth of cut to allow for increased expansion and contraction of the bottom panel unless, of course, you use plywood for the panel.

FIG. 7
Calculating stop positions

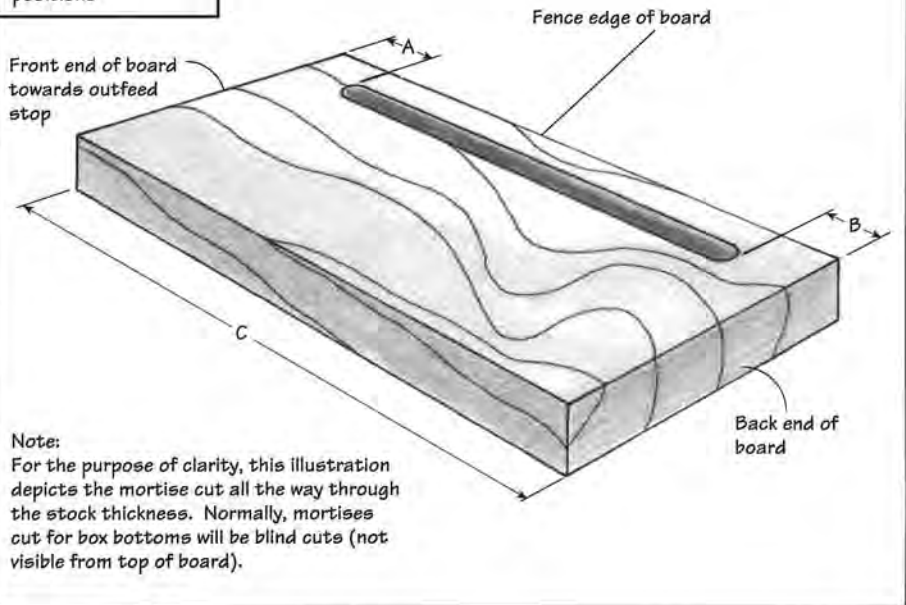

Set the Outfeed Stop

1 After installing the bit you wish to use, set the fence to bit distance at about 1". Place a square cut piece of scrap stock against the fence with the end of the board against the infeed side of the bit. Turn the bit to find the high spot.

2 Next, lock an INCRA Stop to the fence on the outfeed side of the bit with the nylon stop screw as close as possible to the end of the board. Adjust the position of the nylon screw until both the screw and the bit contact the end of the board.

3 Now slide the scale on your Fence System to align dimension (B) on the scale with the end of the INCRA Stop nearest the bit.

Note: The "Zero" end of the scale should be facing the infeed end of fence.

4 Move the INCRA Stop away from the bit to the dimension on the scale that corresponds to the length (C) of the stock you will be cutting. (See Fig. 8)

For instance, after setting the scale to read $\frac{3}{16}$ " at the end of the INCRA Stop, if your board is 5" long, move the INCRA Stop to 5" on the scale and lock in place. The position of the outfeed stop always controls the distance from the end of the groove to the back end of the board. Using this method, if you wished to cut a groove that was open on the front end of the board but stopped $\frac{3}{16}$ " from the back end on a 6" board all you would have to do is move the stop to 6" on the scale after the initial setup. If you change to a 7" board, set the stop to 7", etc.

FIG. 8
Outfeed stop setup

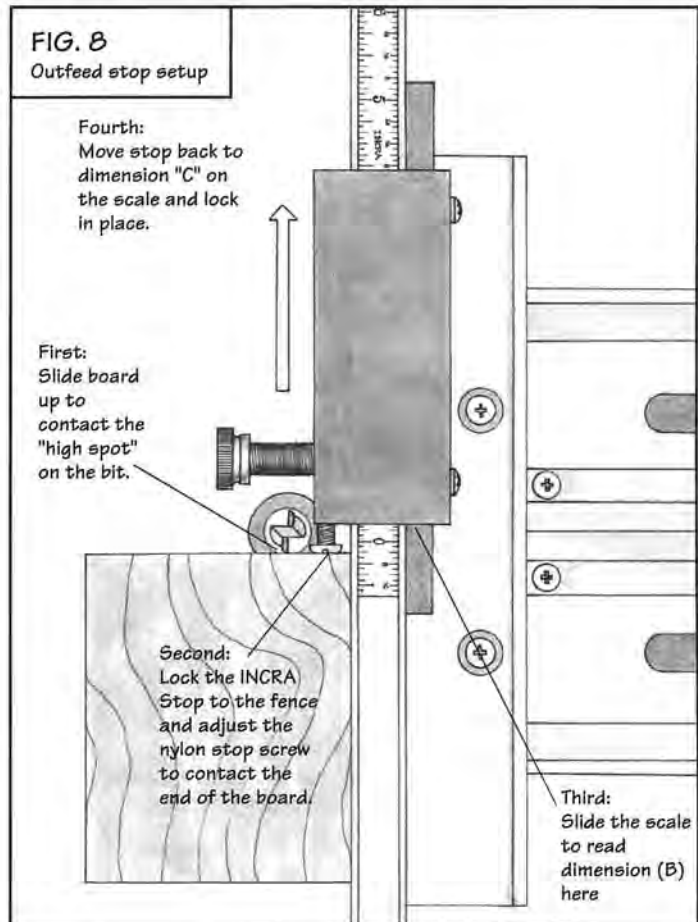

Set the Infeed Stop

- 1** Setting the infeed stop is done in exactly the same way that you set the outfeed stop. Begin by sliding the square cut scrap of stock up to the outfeed side of the bit. Again, make sure the high spot on the bit is in contact with the board.
- 2** Lock a second INCRA Stop to the fence on the infeed side of the bit with the nylon stop screw as close as possible to the end of the board. Adjust the position of the nylon screw until both the screw and the bit contact the end of the board.
- 3** Reverse the direction of the scale in your fence so that the "zero" on the scale faces the outfeed end of the fence.
- 4** Slide the scale on your Fence System to align dimension (A) on the scale with the end of the INCRA Stop nearest the bit.
- 5** Move the INCRA Stop away from the bit to the dimension on the scale that corresponds to the length (C) of the stock to be cut. (See Fig. 9.)

You can now set the fence to bit distance ($\frac{3}{16}$ " for all boxes in this book) and cut the stopped grooves for your box bottoms. The neat things about this technique are that the only time you'll need to pick up a ruler is to measure the length of the board being cut, and no math is necessary. Whenever cutting a stopped groove, always start with the back end of the stock against the infeed stop and carefully lower the stock onto the spinning bit (Fig. 10). Then push the board forward until the front end of the board contacts the outfeed stop, being careful not to force the board against the outfeed stop. Use a slow, steady feed rate and let the bit do the cutting. After making the cut, I prefer to slide the board back to the infeed stop to clean out the groove.

TIP To make the cutting operation super safe, attach a small gate handle (available at your local hardware store) to a scrap of $\frac{3}{4}$ " x 3" x 6" stock, see Fig. 11. You could also bandsaw the handle shape out of a scrap of wood. This push block can now be temporarily attached to the stock you are cutting using double-sided tape and used as an aid in lowering the stock onto the spinning bit and lifting it off after the cut is complete. Make sure the push block does not interfere with your stock's contact with the fence or either of the INCRA Stops.

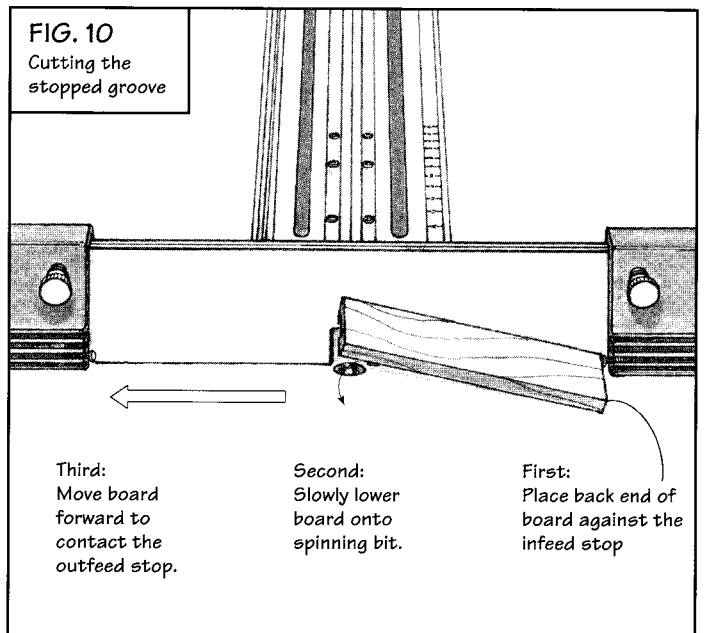
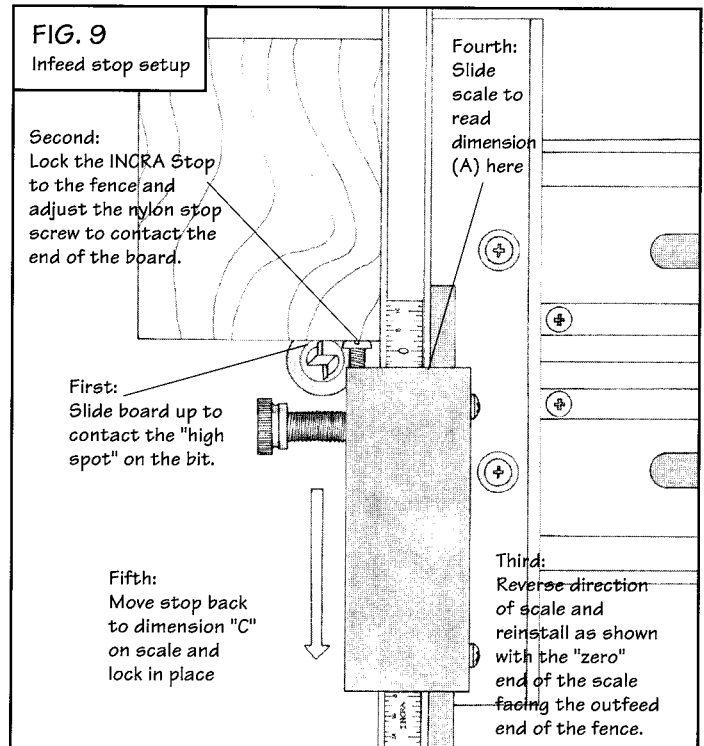
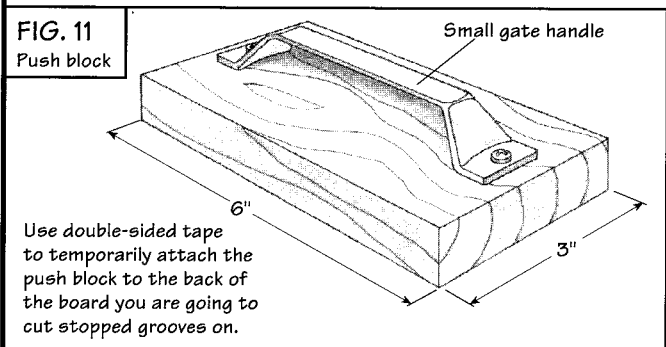

The Bottom Panel

After cutting the grooves on all four sides of your box, cut the bottom to fit. The boxes in this book all use a bottom panel that is $\frac{5}{16}$ " wider and longer than the inside dimensions of the box, so if the inside of your box measures 5" x 7" cut the bottom panel to $5\frac{5}{16}$ " x $7\frac{5}{16}$ ". If you live in a particularly humid region of the country, increase your depth of cut to $\frac{1}{4}$ " when cutting the grooves and cut the bottom panel $\frac{3}{8}$ " wider and longer than the inside dimensions of the box.

Lining with Leather

I'll never forget my first few attempts at lining boxes with leather. The boxes were complete and they looked good. There they sat, next to a can of 3MTM Spray Mount adhesive and a large uncut piece of leather. The task seemed easy in theory - cut the leather to the proper size, spray the piece with adhesive and drop it in place in the box. In practice, I found the task a frustrating mess. First the leather stuck to the sides of the box on the way down. I pulled it loose and continued my descent. Finally the leather met the bottom. I let go of the edge and began to press the piece into place. To my dismay, the piece wasn't centered properly. "Well, I'll just slide it into place," I thought. **NOT!** When 3MTM Spray Mount sticks, it really sticks. It took some effort on my part to pull the leather out of the box. I took a deep breath and decided to try again. That's when I discovered the piece of leather was now about an inch longer than it was originally. The adhesive coated leather had stretched when I pulled it out of the box. There had to be a better way.



Lining with leather, as we've done with the jewelry box shown above, adds a beautiful finishing touch to your boxes.

A Better Way

1 Measure the inside dimensions of the box or compartment that you wish to line with leather, then subtract $1/32$ " from the length and width. Cut a piece of $1/4$ " plywood to this size.

Example:

If the inside of your box measures 6" x 9", cut the $1/4$ " plywood to 5- $31/32$ " x 8- $31/32$ ".

2 Glue a scrap block of wood to the piece of plywood to act as a handle. Fig. 1. The size of the plywood should be adjusted as necessary so that when it is set just inside the top rim of the box and released, it floats to the bottom of the box without binding.

FIG. 1
Cut $1/4$ " plywood to fit inside box

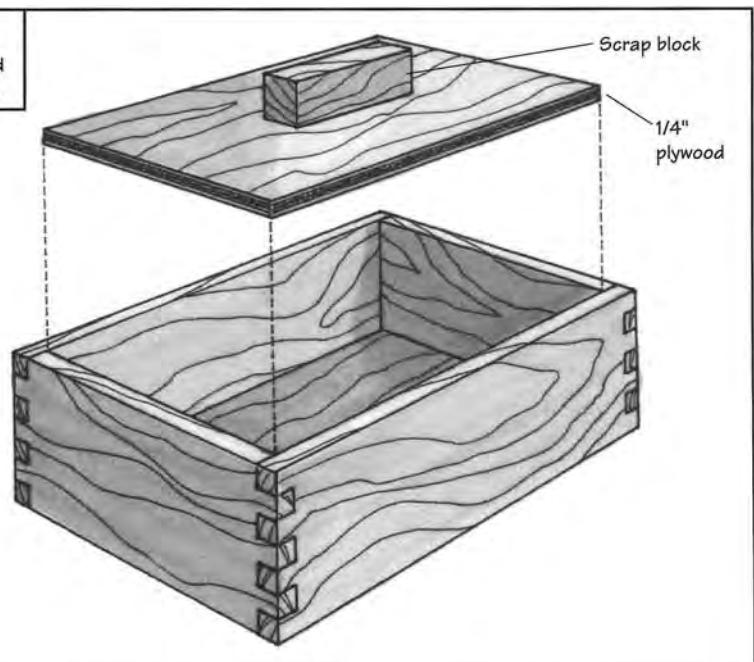

3 Spray a very light coat of adhesive on the face of the plywood piece. After spraying, press the adhesive side of the panel down on a cotton towel several times. This further decreases the holding power of the adhesive so that it will just barely hold a scrap of leather when stuck to it.

4 Now press the plywood down on your piece of leather and, using a sharp X-acto® knife, cut around the edges of the piece of plywood. Make sure you cut all the way through the leather before lifting the plywood. Fig. 2.

5 Carefully lift the plywood panel with the leather attached to its face and wrap a piece of masking tape all the way around the edges of the plywood. The tape should also overlap the edges of the leather. Fig. 3.

6 Spray a generous coat of adhesive on the surface of the leather. (When working with any spray adhesive, always make sure that your work area has sufficient ventilation to prevent hazards from fumes.) I usually place the plywood piece inside a cardboard box when spraying the adhesive to avoid getting glue on everything else in my shop. See Fig. 4. Lean the plywood on a scrap of wood or the back of the box.

7 Remove the masking tape from the edges of the plywood panel. This leaves clean, glue-free edges on the panel. Now simply set the panel inside the top rim of your box and press the leather down to the bottom. Pull up on the handle attached to the plywood and the panel should easily separate from the leather, leaving a precisely and cleanly placed liner in your box. I usually press the leather in place again with a small scrap block of wood to ensure good adhesion. You can also use the scrap to scoot the edges of the leather right up to the walls of your box if any gap lines exist.

So there you have it, the plywood piece acts as both a pattern to cut the leather and as a holding device to handle the otherwise elastic and very sticky material with ease. If you are making the same size box, you can use the panel over and over again, and it can always be cut down to a smaller size if you want to use it for a smaller box.

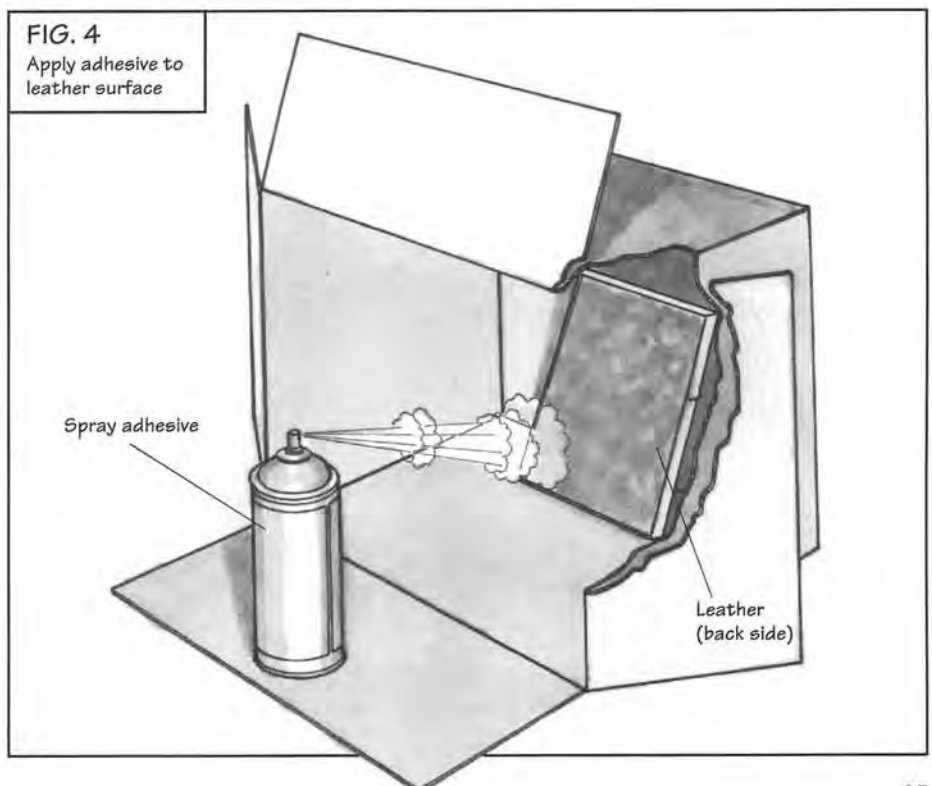
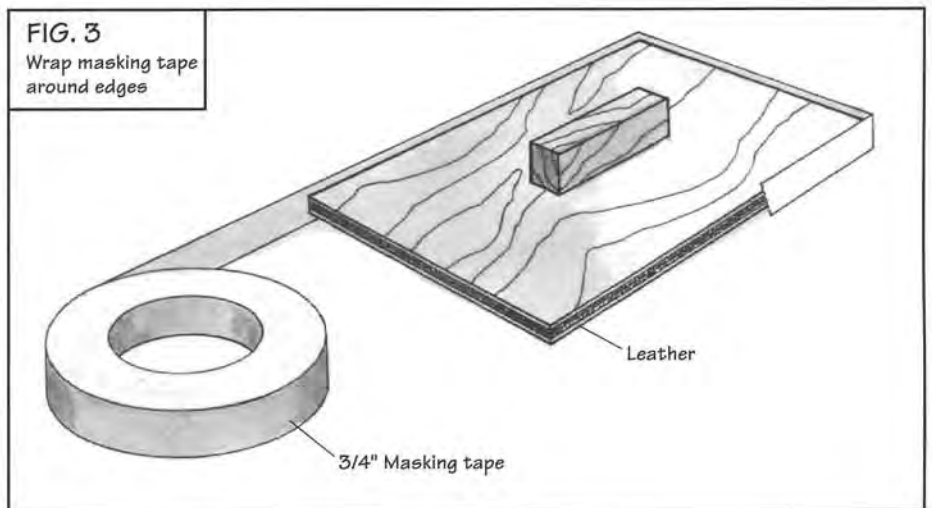
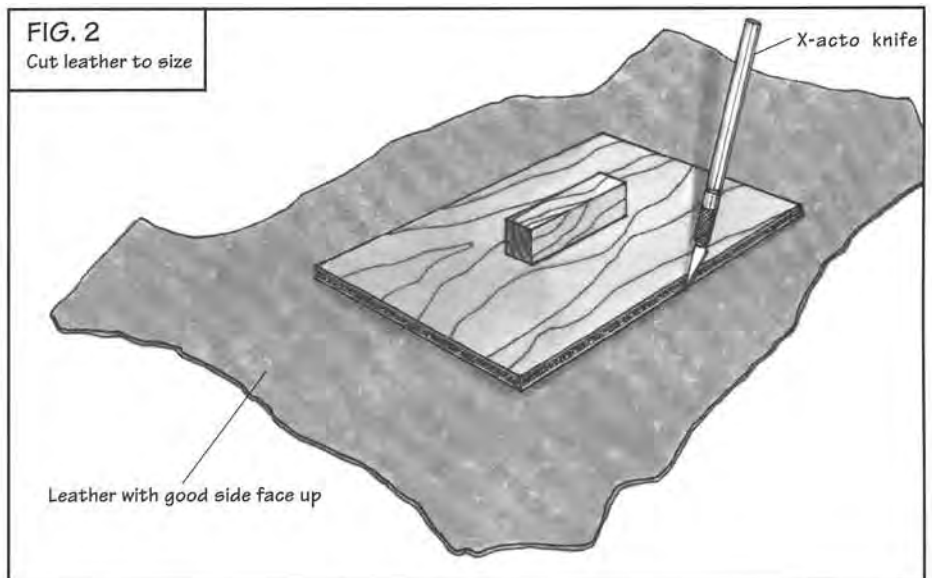

Compartments and Lift Out Trays

This section describes a technique you can use to install dividers and a lift out tray in your jewelry box, but the method could be used for any number of projects from shadow boxes to shoji screens. Rather than using the common edge-cut half lap joint at the divider intersections, I prefer a series of rabbets and dados using the INCRA JIG to position the cuts at the router table. The method is quite easy and, as with any INCRA JIG operation, is always repeatable.



Design

When designing the layout for section dividers in a box, begin by thinking what the box might be used for. Different uses call for different sized compartments. One easy way to build a compartment design is to draw the interior dimensions of your box full scale on a sheet of paper. Then, using horizontal and vertical lines, subdivide the space into a grid of equal sized units as shown in Fig. 1. Now, to make this equal pattern a little more interesting, erase a few of the connecting lines. Fig. 2. This is where the box's intended use comes into play. Create larger spaces as necessary, but avoid inside corners in the interior space. Fig. 3. This method will always produce a visually pleasing geometric pattern with each of the larger spaces being a multiple of the smaller unit.

Required Bits

1/4" straight bit



SEE ALSO

Trinket Box	132
Jewelry Box	138

Designing compartment patterns

FIG. 1

Draw a grid of equal units to fit within your box dimensions

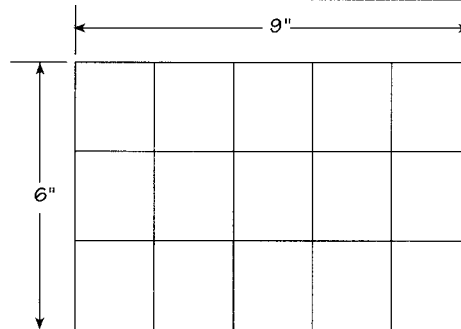

FIG. 2

Erase a few of the connecting lines to add variety

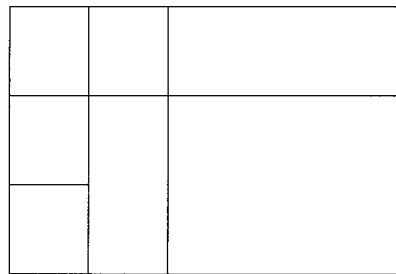
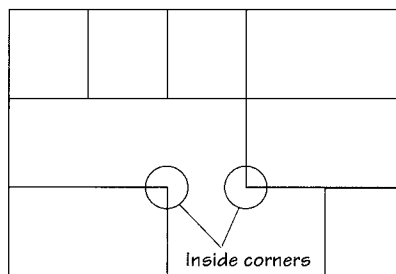
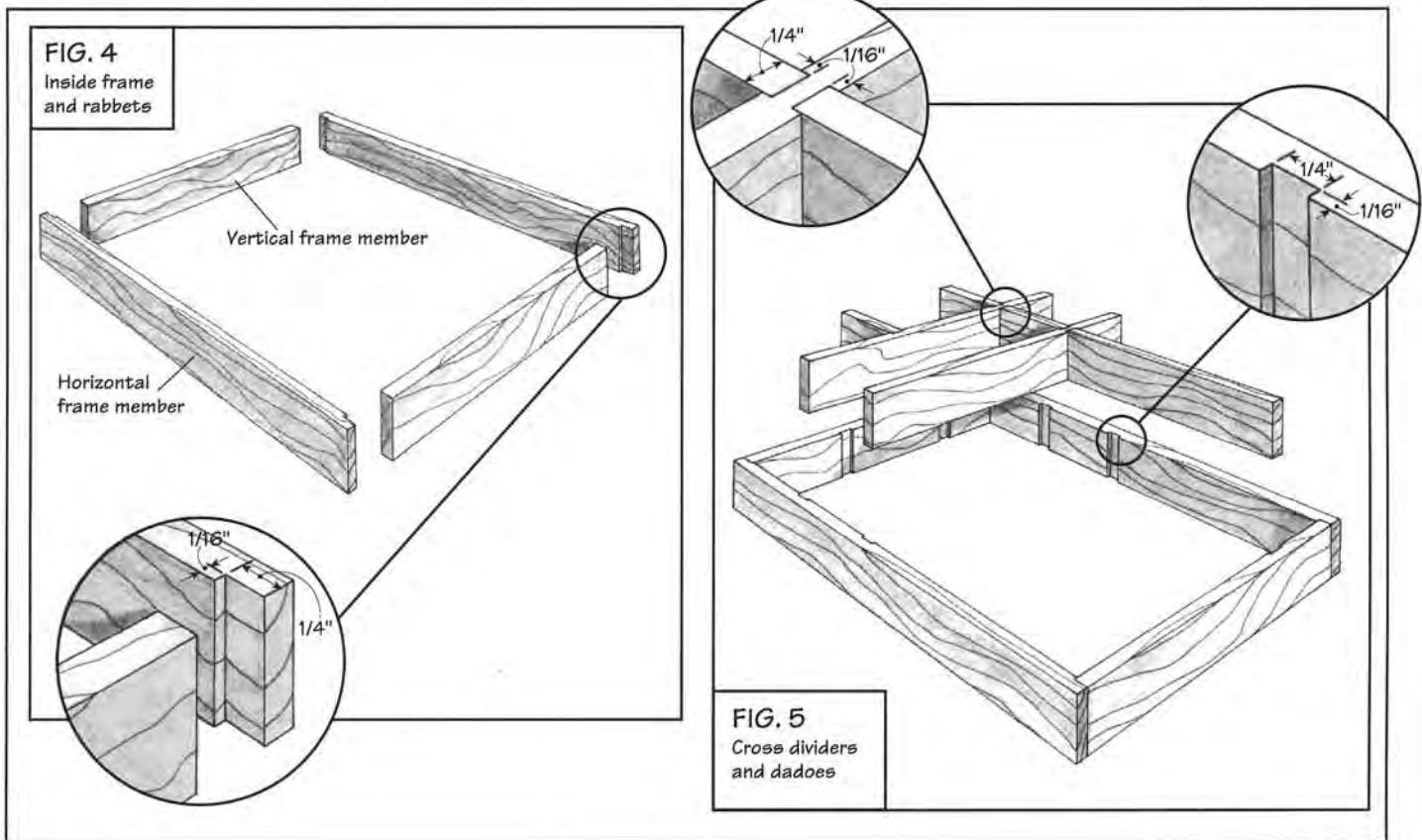

FIG. 3

Avoid inside corners





Joinery and Cut Placement

I start my box compartments with an inside frame. The frame is cut to fit the box using $\frac{1}{4}$ " thick x 1" wide stock. Instead of using mitered corners which requires tilting the saw blade, or a miter cutting jig, I prefer to rabbet the corners. Fig. 4. The cross dividers are added next by using dados cut in the frame and cross dividers where necessary. See Fig. 5.

All of these rabbets and dados are cut at the router table using the INCRA JIG to precisely place the cuts. After laying out the grid design, I use a little math to determine the necessary INCRA JIG positions. If you are not big on math, the best way to determine the INCRA JIG settings is to do a full scale drawing of the grid pattern including the thickness of the dividers. You can then take measurements directly from the drawing.

The technique to follow details the method I use to safely cut these tiny dados and rabbets at the router table. The grid pattern shown in Fig. 2 represents a design I use quite often, so I'll give the measurements used to cut this pattern for the **Trinket** and **Jewelry Box** projects in this book. Before making your dividers, see the Design Tip on page 40 for an idea on dressing up your box compartments. In the description to follow, I will refer to the dividers that parallel the length of your box as horizontal and those that run from the front to the back of your box as vertical.

Router Table Setup

1 Make an auxiliary fence to mount to your INCRA Fence. A piece of scrap $\frac{3}{4}$ " plywood or hardwood, 3" x 28", will do fine. DO NOT cut a notch for the bit recess when making the auxiliary fence. I simply attach the auxiliary fence to my INCRA Fence using a few pieces of double sided tape, but you could drill and counterbore the auxiliary fence to match the pre-drilled mounting holes on your INCRA Fence, then attach it with (2) #10-24 x $1\frac{1}{2}$ " pan head machine screws with washers and hex nuts. See page 107 (**Business Card Case**) for drill and counterbore locations. After attaching the auxiliary fence to your INCRA Fence, install a $\frac{1}{4}$ " straight bit in the router table and "zero" the fence to the edge of the bit. Fig. 6. Slide the scale in your INCRA JIG to position 0" on the scale directly under the cursor.

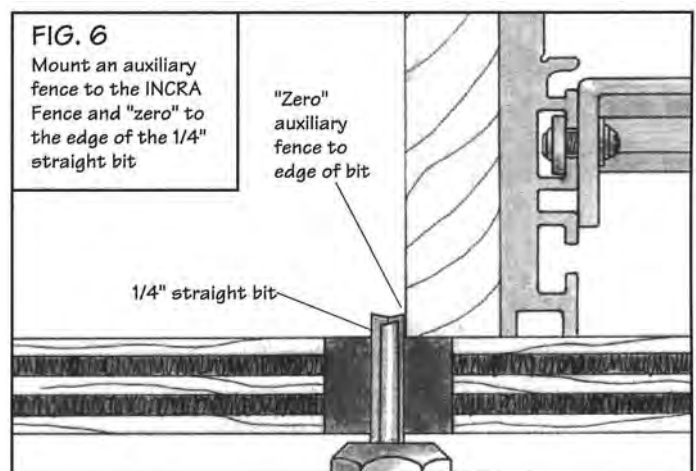

Prepare the Divider Stock

2 Move your INCRA JIG to 1" on the scale and set the depth of cut to $\frac{1}{4}$ ". Cut a test groove in a piece of scrap stock. Take this test groove block with you to use as a thickness gauge if you are buying the $\frac{1}{4}$ " stock that makes up the dividers. You'll need a piece 5" x 24" that yields a tight fit in the test block. I usually resaw a piece of $\frac{3}{4}$ " x 2 $\frac{1}{2}$ " x 24" stock at the bandsaw into two pieces, each slightly less than $\frac{3}{8}$ " thick, then plane the pieces down to a tight fit in the test groove. Sanding will ease the fit later on.

3 Rip the stock to (4) 1" wide strips.

4 Cut the two horizontal frame members to fit the inside of your box's length. Sneak up on the length of these two pieces for a perfect fit.

5 To cut the various rabbets and dadoes on the horizontal frame members as well as the vertical dividers, you'll need a square cut scrap of $\frac{3}{4}$ " plywood or hardwood 8" x 8" square. It is important that the corners of this piece be square since it will be used as a miter gauge to hold the

dividers perpendicular to the fence during the rabbet or dado cuts, as shown in Fig. 7. **Caution:** Keep your hands clearly away from the path of the router bit's cut. When using this method to cut the various dadoes and rabbets, use a forward feed direction only, cutting the dado the length of the backing board. **DO NOT PULL THE STOCK BACK OVER THE BIT AFTER COMPLETING THE CUT.**

6 Set the router bit depth of cut to $\frac{1}{16}$ ". Set your INCRA JIG to 0" on the scale and, using the backing board cut above, cut the rabbets on both ends of the horizontal dividers. Now set your INCRA JIG to 2" and rout a dado on one end of both boards. (If you are cutting a decorative divider as described in the Design Tip on page 40, make sure that the dadoes are placed so that when the dividers are installed the dadoes are opposite each other.) With the same end of the dividers against the fence, set your INCRA JIG to 4" and cut a second dado on each divider. See Fig. 8. The dado cut placement of 2" and 4" will work for both the **Trinket Box** and **Jewelry Box** designs. In fact, this 0", 2", 4" cut placement looks good in any box from 8" to 12" in length.

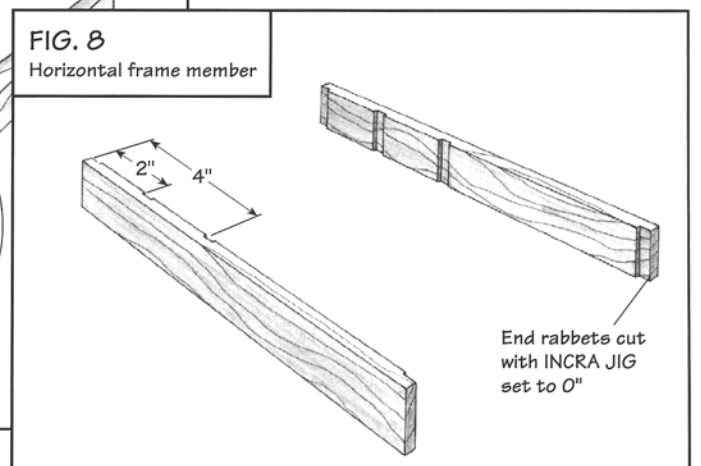
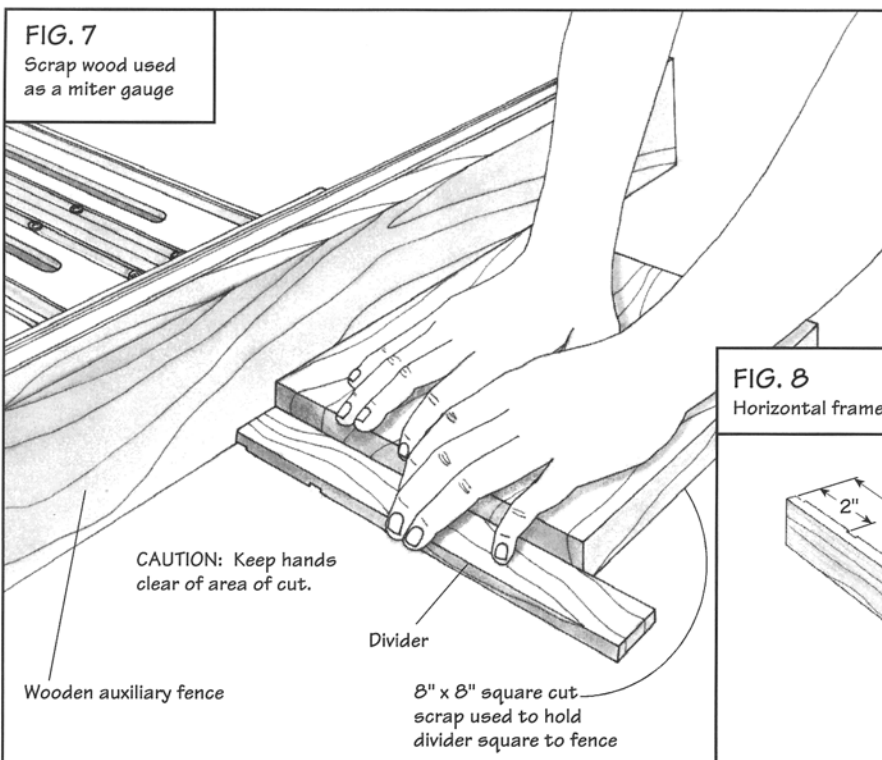
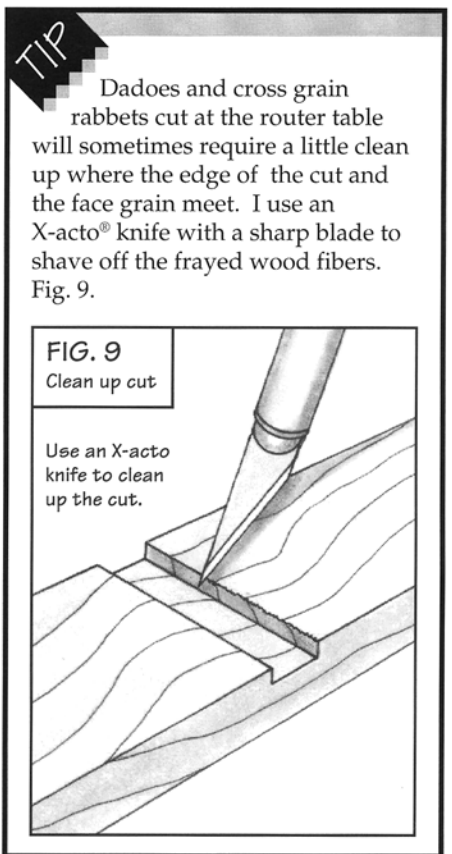

7 Install the two horizontal frame members in your box and cut the two vertical frame members and the two vertical cross pieces to fit. The placement of the dadoes in the vertical pieces requires a little math. I'll describe the formula I use, then give the resulting answers to use for the **Trinket Box** and **Jewelry Box** designs.

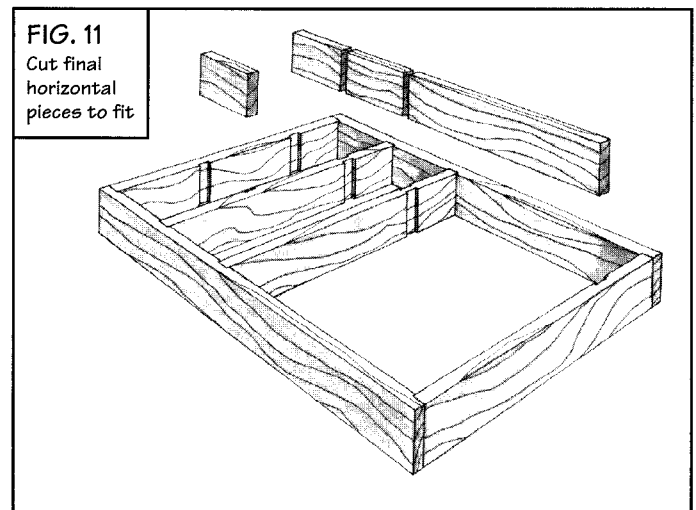
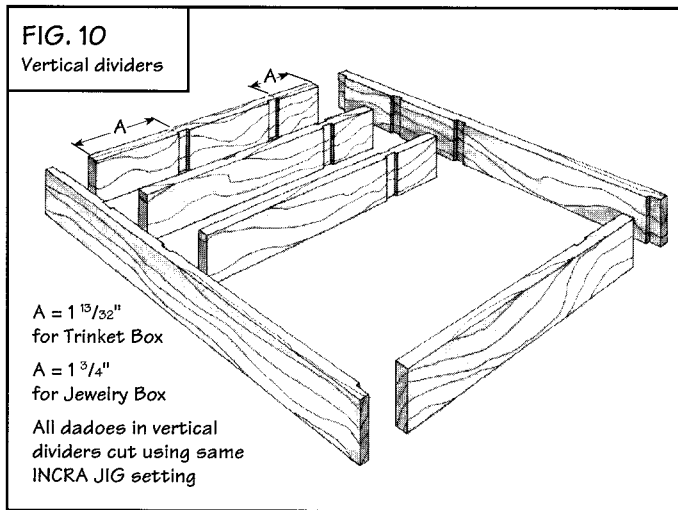

As you can see in Fig. 10, each vertical divider needs a different number of dados. It's a good idea to mark the pieces to ensure proper dado placement. The nice thing is that the fence to bit distance is the same for each and every cut. Here's how I determine the fence to bit distance: First, subtract the combined thickness of the four horizontal dividers from the inside width (front to back) of the box. Divide the answer by 3. (Dimensional calculators are very handy

for this.) Now add $1/16$ ". Since INGRA JIG moves in $1/32$ " steps, if the answer is in 64ths, I round up to the nearest 32nd.

For the **Trinket Box** the fence to bit distance is $1^{13/32}$ ".

For the **Jewelry Box** the fence to bit distance is $1^{3/4}$ ".

8 Set your INGRA JIG to the appropriate scale setting for the box you have made and make

the cuts shown in Fig. 10 on the vertical dividers.

9 You can now cut the four remaining horizontal cross pieces to fit. Fig. 11.

10 Lightly sand and finish the dividers. If you intend to install leather in your box bottom as described on pages 34-35, do so before permanently installing the dividers.

Lift Out Tray

The lift out tray sits on top of the horizontal frame members beneath it. The tray is designed so that the center horizontal divider is aligned with one of the horizontal dividers in the compartments below. The overall width of the tray is dimensioned so that when the tray is slid all the way to the left of the **Trinket Box** or **Jewelry Box** the sides of the tray are aligned with the vertical dividers below. The tray is basically a small box with rabbeted joinery and two captured bottom panels.

Here's How

1 With the auxiliary fence still mounted to your INGRA Fence, set your $1/4$ " straight bit to a $1/8$ " depth of cut.

2 Cut the pieces to length as shown in the Exploded View. The long sides need to be cut $1/32$ " shorter than the width of your box so that the tray slides easily from left to right without binding between the front and back of the box.

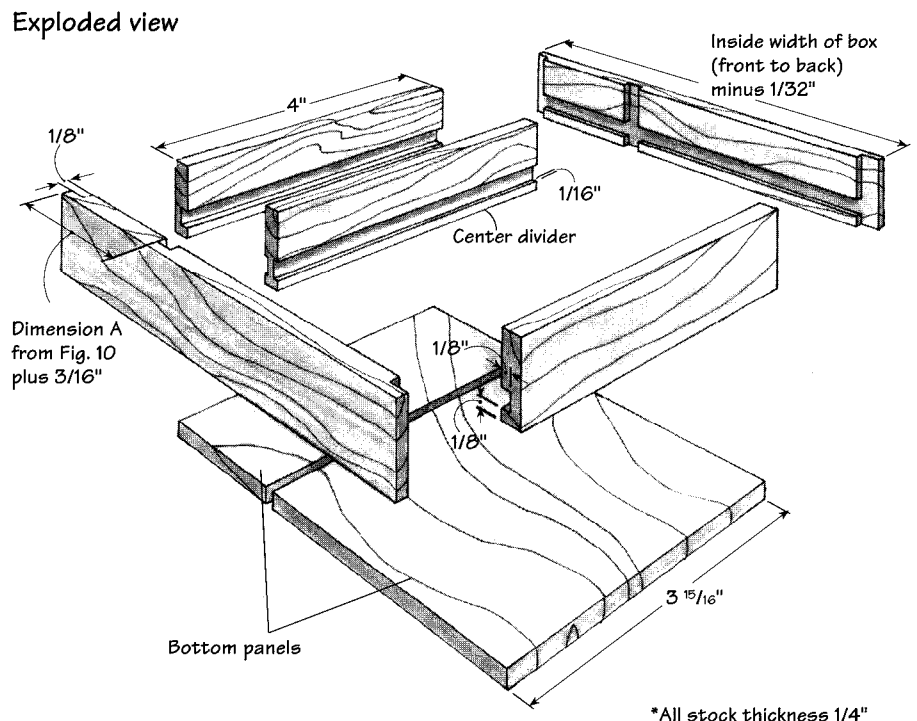

3 Set your INCRA JIG to 0" and cut the rabbets on both ends of the two longer sides. Use the backing board method as described in Step 5 on page 38.

4 Cut the two opposing dadoes in the longer sides. If you are making the tray for the **Trinket Box**, set your INCRA JIG to $1\frac{19}{32}$ ". If you are making the tray for the **Jewelry Box** design, set your INCRA JIG to $1\frac{15}{16}$ ".

5 Set your INCRA JIG to $\frac{1}{8}$ " on the scale and cut the grooves for the bottom panel in the four sides of the tray. Be sure to use a rubber soled push block for this operation. **DO NOT** cut grooves in the center divider yet.

6 Lower the depth of cut to $\frac{1}{16}$ " and with the INCRA JIG still set to $\frac{1}{8}$ ", rout the grooves for the bottom panel on both sides of the center divider. Again, be sure to use a rubber soled push block.

7 Cut the $\frac{1}{4}$ " thick bottom panel to $3\frac{15}{16}$ " wide. Use the same color stock that was used for your box bottom. To determine the length (with the grain) of each of the two panels, dry assemble the tray and cut each panel's length to $\frac{5}{32}$ " greater than dimensions A and B shown in Fig. 12.

8 Sand the pieces before gluing up the tray.

FIG. 12
Bottom panel size

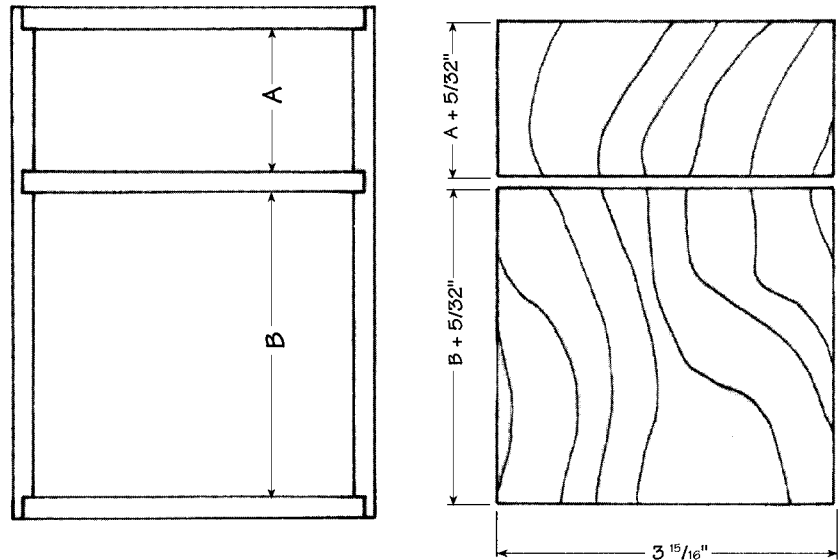

9 If you wish to line the lift out tray's compartments with leather, use the technique described on pages 34-35, making a separate pattern for each compartment.

Design Tip

To give your section dividers and lift out tray a dramatic touch that really dresses up your box interior, add a $\frac{3}{32}$ " strip of contrasting color wood to the top of each of the dividers. See photo on page 36. I use the same color wood for this strip that I used in the trim section of my box joinery. Of course, adding this strip of wood to one divider at a time is much too tedious, so to save time, I begin my section dividers with a lamination. See Fig. 13. Starting with $\frac{3}{4}$ " stock, cut the pieces to the dimensions shown on the right side of the drawing and glue them up. When the glue dries, joint one face, then resaw the lamination at the bandsaw to yield two pieces, each a little less than $\frac{3}{8}$ " thick. These can now be planed down to $\frac{1}{4}$ ". The 1" wide strips for the dividers are then ripped from the stock.

FIG. 13
Lamination for section dividers and tray

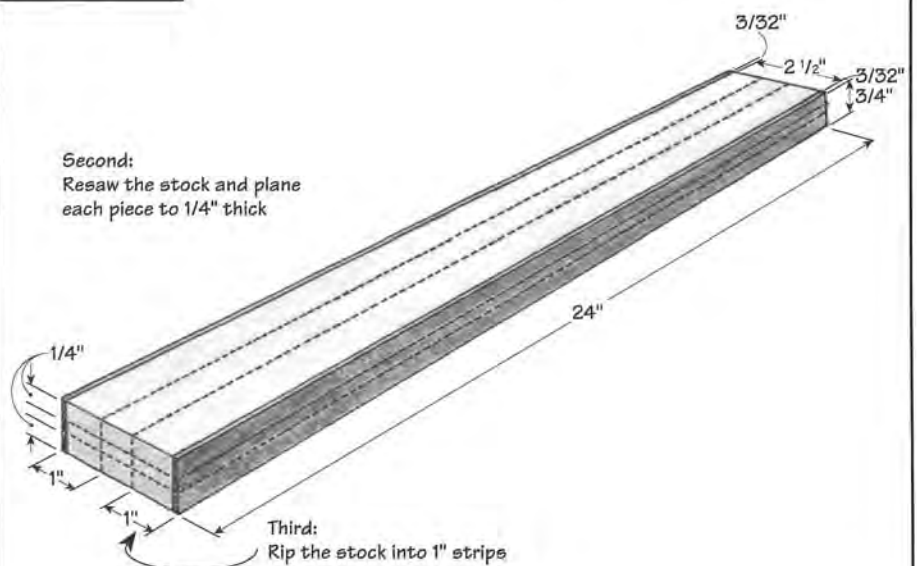

Strip Laminations

If you own a thickness planer, one of the easiest and most satisfying ways to decorate a box is through the use of strip laminations. They can look simple like the five piece lamination used in the **Playing Card Box** tops shown here, or they can look complex like the 34 piece lamination for the **Cutting Board** shown on page 82. Strip laminations can be used to create dramatic visual effects, and with the positioning accuracy of the INCRA JIG at the table saw, the overall width of a lamination can be controlled precisely, making it easy to align details in the top with details in the corner joinery as shown in the **Domino Box** on page 129.



Strip laminations, like the one shown on the **Playing Card Box** above, are a beautiful and easy way to decorate your projects.

The Tools

- **Thickness Planer** - used to surface the faces of the lamination after glue up.
- **Table Saw with INCRA Fence System** - used to position and cut the stock into strips.
- **Light Duty Bar Clamps** - you'll need at least 5 or 6 clamps.
- **Zero Clearance Throat Plate for the Table Saw** - With a zero clearance throat plate there is no gap between the saw blade and the slot in the throat plate, Fig. 1. This keeps the thin strips from getting pulled by the saw blade into the saw, which can be a very unpredictable and dangerous situation.
- **Quality Carbide Tipped Blade** - The ability to cut a thin strip at the saw and go straight to glue-up without a secondary operation to smooth the strip is often a function of the quality saw blade. My favorite blade is a Forrest 40 tooth combination blade with a $\frac{1}{8}$ " kerf. It gives me the smooth cuts necessary to produce an "invisible" glue line. There are many other comparable blades as well.

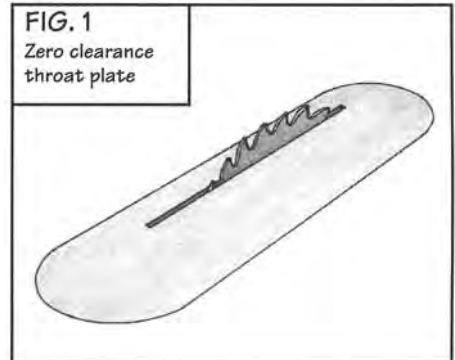

Cutting Thin Strips

1 Let's say I want to create a lamination with (4) $\frac{1}{32}$ " strips of dark wood, (3) $\frac{3}{8}$ " strips of light wood and (2) 2" wide border strips. See Fig. 2. For safety, I always cut the strips from a wide board, about 5" wide or wider. At the table saw, set the fence to blade distance at $\frac{1}{32}$ " less than the width of the stock you are cutting and trim the outside edge of the board. See Fig. 3. Always lightly trim the outside edge before cutting the first strip to ensure the first strip will be the proper dimension. If cutting the $\frac{1}{32}$ " strips first, advance the fence toward the blade $\frac{1}{32}$ " plus the width of the saw kerf. My blade has a $\frac{1}{8}$ " kerf, so in order to cut $\frac{1}{32}$ " strips,

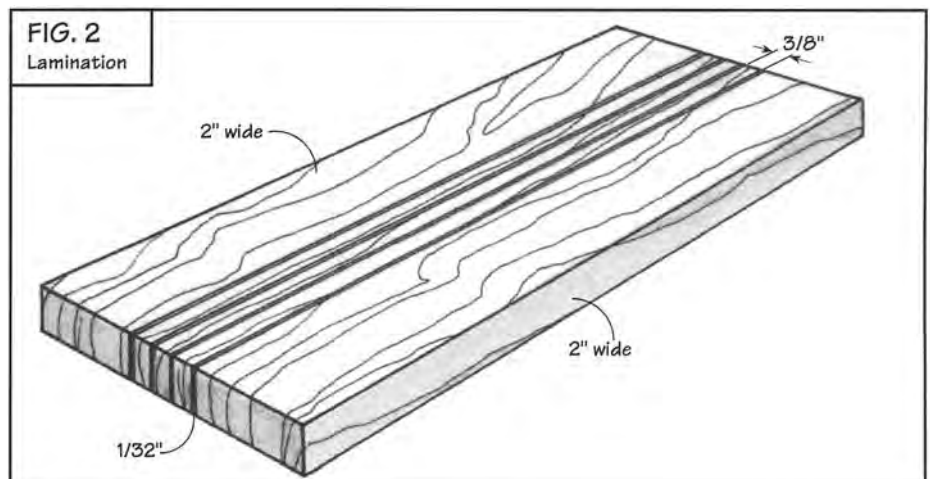

I advance the fence $\frac{1}{32}$ " plus $\frac{1}{8}$ " and make the cut. The strip will be cut off of the left (or outside) edge of the board. See Fig. 4.

Caution: When cutting very thin strips it is **required** that you first install a zero clearance throat plate in your table saw. (See Fig. 1 page 41.) This keeps the thin strips from getting pulled down into your saw. **After each cut, turn off the saw and allow the blade to come to a complete stop before moving the cut off strip away from the saw blade.**

2 The same process is used to cut the $\frac{3}{8}$ " strips. First trim $\frac{1}{32}$ " off the left edge of the stock.

Advance the fence $\frac{3}{8}$ " plus the width of the saw kerf. The precise positioning of INCRA JIG guarantees consistent strip width.

Orient the Pieces

3 After cutting the $\frac{3}{8}$ " strips and the 2" border strips, dry assemble the lamination. It is at this time that you should arrange all the pieces in the lamination for proper edge grain alignment. Fig. 5a shows *improper* edge grain alignment. On piece 1 the edge grain arcs downward toward the front edge of the board and on piece 2 the edge grain arcs upward. If these two pieces were joined as shown and then run through the thickness planer, one of the two pieces would surely have some tearout as a result of planing against the grain.

4 For smooth planing, orient all the pieces in the lamination so that the edge grain arcs the same direction toward the front. Fig 5b.

Glue-up

5 Now stack the properly oriented pieces vertically in front of you as shown in Fig 6. Remove the top piece, turn it upside down and place it in front of the stack. Apply a thin bead of yellow woodworker's glue on this piece as well as the piece on top of the stack. Spread the glue evenly on each piece using a thin strip of scrap wood. Don't worry about glue runoff. Remove the top piece from the stack, turning it upside down and set it on top of the piece in front of the stack. Repeat this process until all of the pieces are glued. Work as quickly as possible to avoid the glue drying prematurely.

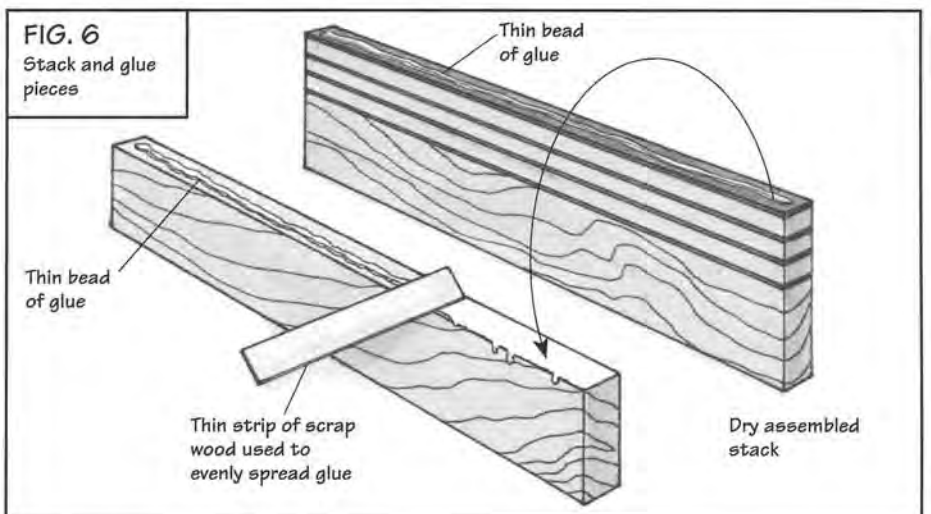
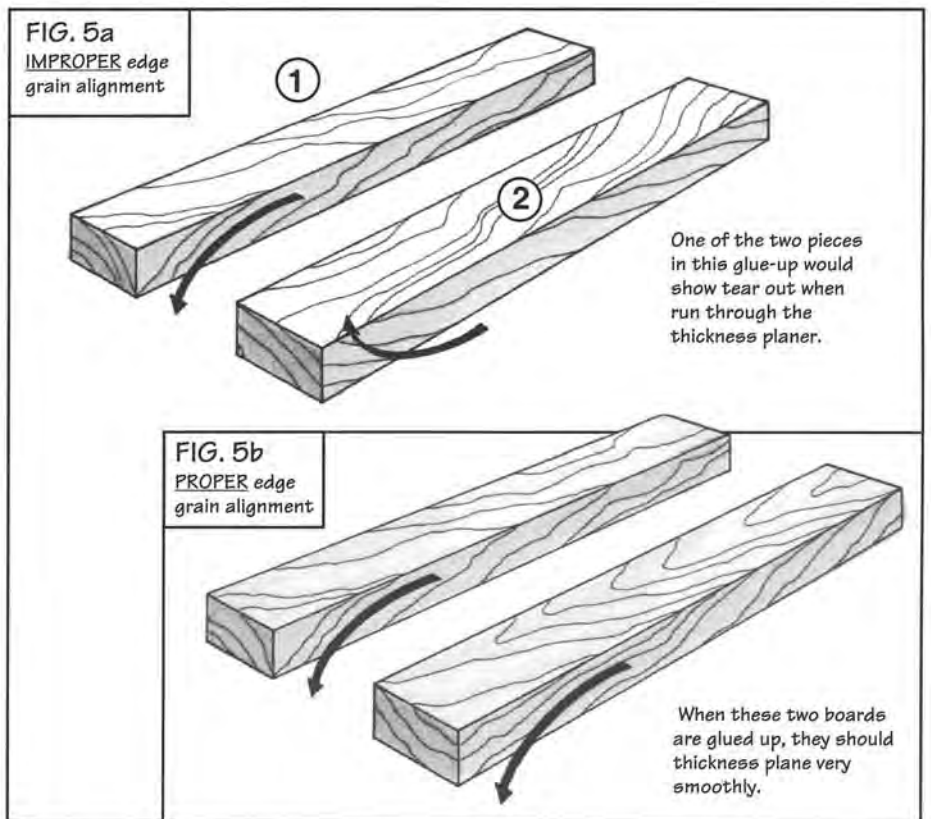
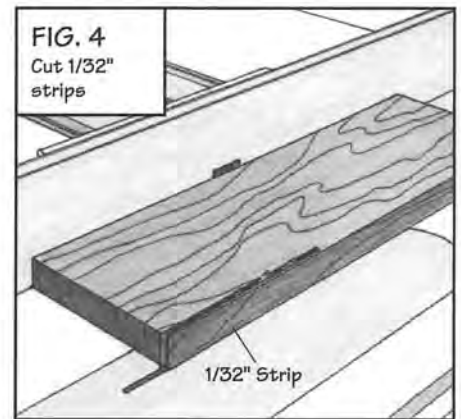
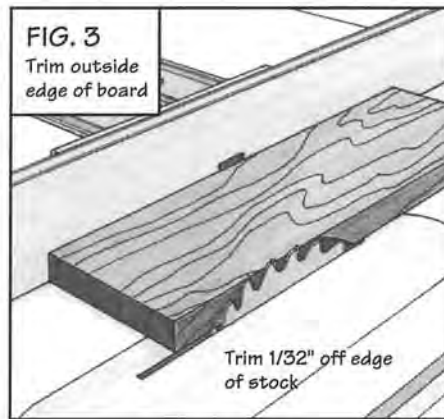

Clamping

6 Lay the lamination on a piece of wax paper or cardboard on a flat surface and slide the pieces to align the face flush if necessary. Apply the clamps from the center outward using only light pressure until all clamps are in place, then tighten. To avoid marks left by the clamps, place a strip of scrap stock between the clamps and the lamination. Space the clamps 4" or 5" apart. Some misalignment will occur during tightening and it may be necessary to loosen a clamp or two to realign, but remember this, "DON'T SWEAT THE SMALL STUFF". If the misalignment is only $\frac{1}{32}$ " or so, don't fight it; you can surface plane the defects out later. If the lamination cups during clamping, apply a few clamps on one side of the lamination, flip it over and apply the remaining clamps on the opposite side. This should equalize the clamping pressure and yield a fairly flat panel. You can wipe off the glue that squeezes out if you like, but it's not absolutely necessary. For best results, allow the lamination to dry overnight.

Surface Plane

7 Use a paint scraper to remove the excess glue squeezed out during clamping, then lay the lamination on a flat surface and check for twist. One face is usually flatter than the other. If you have a jointer, joint this surface smooth first. Otherwise, this flat side should be fed face down through the thickness planer so that the planer will surface the opposite side first. Unless you are surfacing to a specific thickness, plane the pieces until both faces are smooth, and no more.

Keep it simple at first. Don't overwhelm yourself with a 20 piece lamination on your first attempt. Further, don't make the lamination 10 feet long. Make several shorter laminations instead - variety is the spice of life. I seldom make a lamination any longer than 24". The shorter lamination may only provide one or two tops, but it allows ample time to assemble the strips before the glue sets. Make the laminations about 4" longer than the necessary finished length. The extra length makes up for any planer snipe that might occur during surfacing. If your planer does not snipe the ends, this extra 4" is not necessary. Have Fun!

A Word of Caution

Most thickness planer manuals recommend a minimum length for safe surfacing - mine says 12". If you desire a shorter lamination, cut the two outside "border strips" to the minimum length as recommended by your planer manual. The internal strips can be shorter. See Fig. 7. The ends of the border strips can be cut off after surfacing.

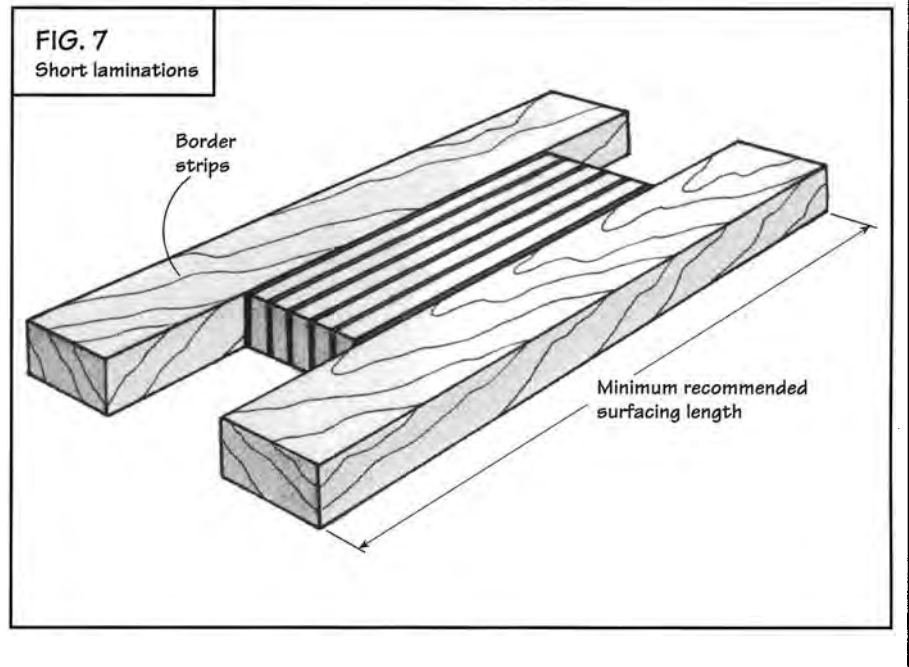

Hinge Mortising Template

Cutting mortises for the INCRA wooden hinge had always been a tense operation for me. The common method involved outlining the hinge positions on the box and lid, routing the majority of the waste with a hand-held router and then chiseling out the remainder to the outline. A single slip of the router or chisel could ruin an otherwise flawless jewelry box. Even after cutting about 100 or so hinge mortises, I found the time required to cut the last mortise was about the same as the time required for the first. So I was quite overjoyed when I discovered a method for template routing the mortises.

The template routing method still requires layout of the hinge locations and the use of a hand-held router, but this time the router has a guide bushing attached. The guide bushing follows the edge of a plywood template to precisely dimension the hinge mortise, and the template is fitted with a fence for accurate positioning. This time-saving technique has made hinge mortising a worry free operation that is both accurate and repeatable. Try it and I think you'll agree.

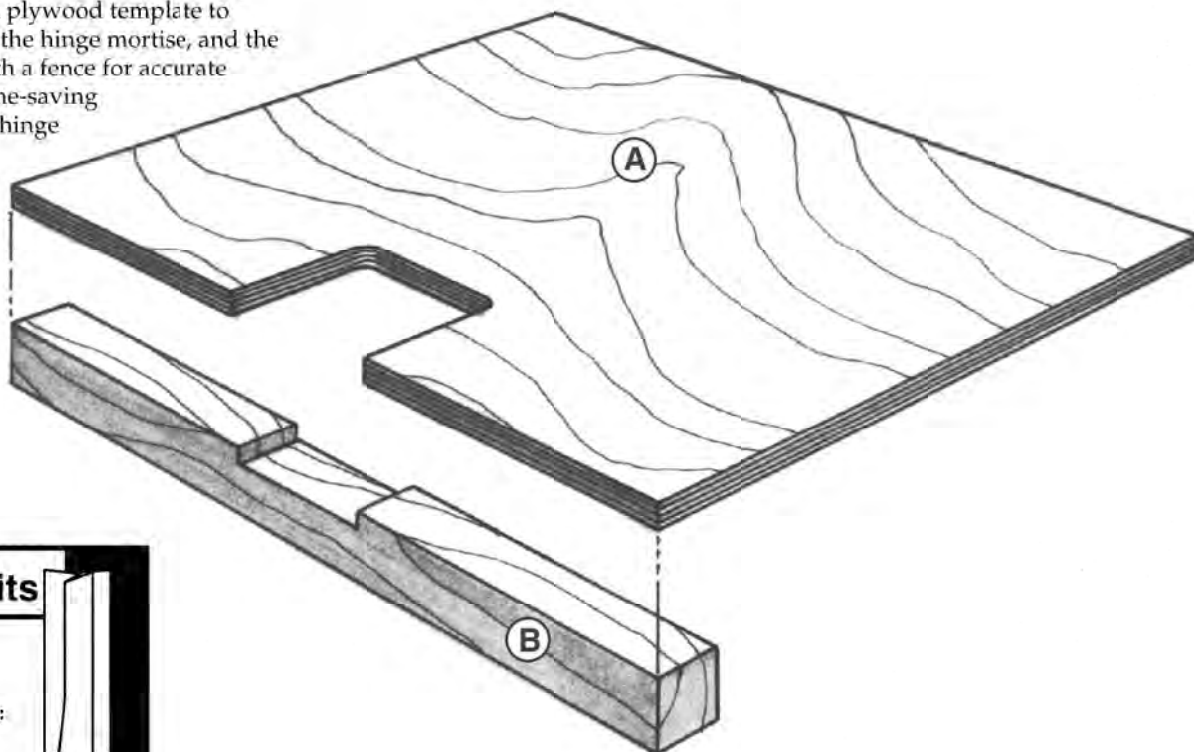

Required Bits

To make template:
1/2" flush trim bit

To use the template:
1/2" guide bushing
1/4" straight bit

SEE ALSO

Trinket Box 132

Jewelry Box 138

Materials List		T	x	W	x	L	Material
A	Template	1/4"		8"		10"	Baltic birch plywood
B	Fence	3/4"		3/4"		10"	Hard maple

3/4" x 3 1/2" x 10" Hard maple

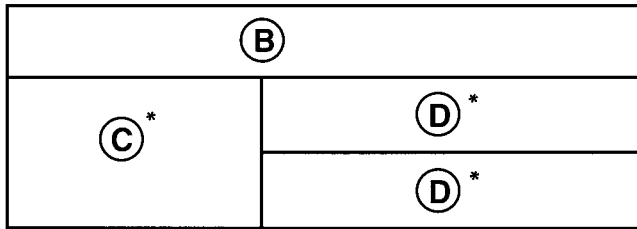

* Pieces C and D are used to make primary template. (See Step 1 for dimensions.)

Cutting Diagram

1/4" x 8" x 10" Baltic birch plywood

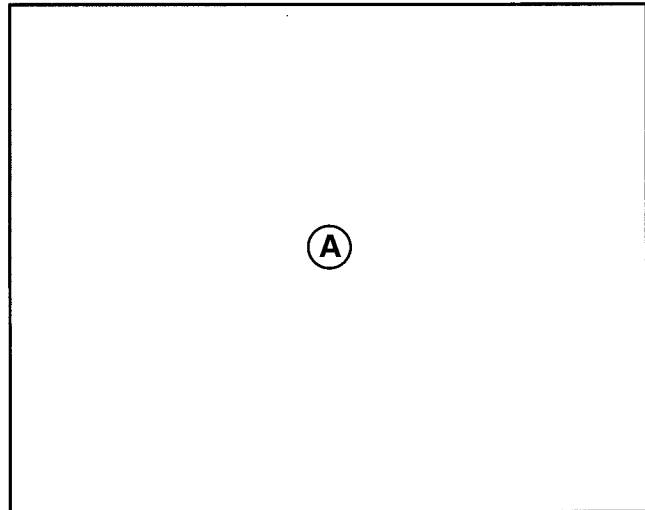

Making the Template

The Primary Template

1 The cutout in the plywood template must be accurately dimensioned and placed. The dimensions will be controlled through the use of a very simple primary template. See Fig. 1. To make the primary template, cut the 3/4" hard maple stock to the dimensions shown in the drawing. Set the primary template on a flat surface and clamp the three pieces together. No need for glue.

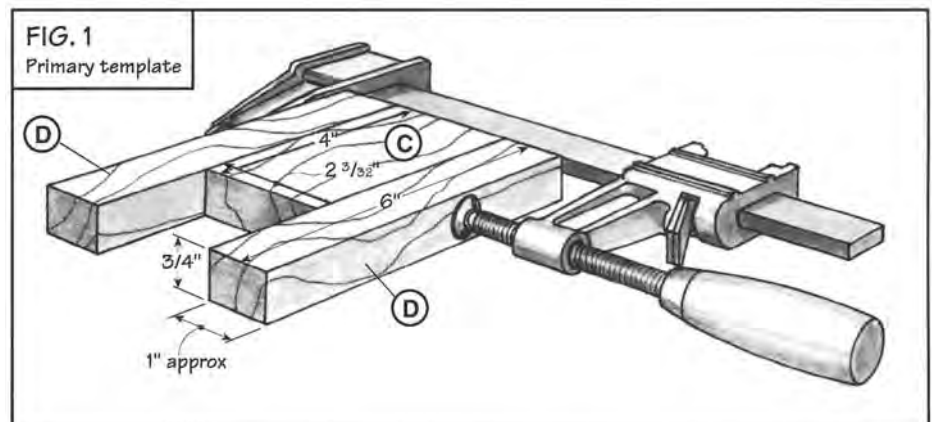

TIP

The primary template shown is dimensioned to create a cutout in your plywood template that, when used with a 1/2" o.d. guide bushing and a 1/4" straight bit, will cut hinge mortises for the 1 27/32" length of the INCRA wooden hinge. If you would like to make the hinge mortising template for use with another router bit/guide bushing combination or a different hinge length, the only change you'll need to make in the primary template is the width of the center piece (C). The width of the center piece should be equal to the hinge length plus two times the offset between the router bit and guide bushing. The offset is the distance from the edge of the bit to the outside of the guide bushing (Fig. 2) or, put another way, the offset is found by subtracting the diameter of the bit from the outside diameter of the guide bushing, then dividing the answer by two.

FIG. 2

The offset between the router bit and guide bushing

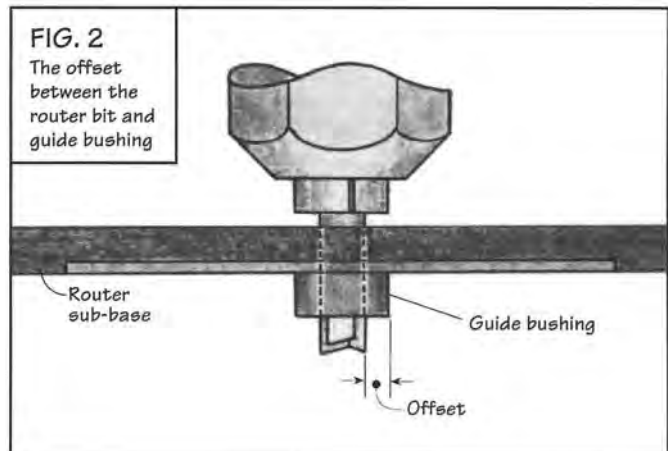

FIG. 3

Attach primary template to plywood

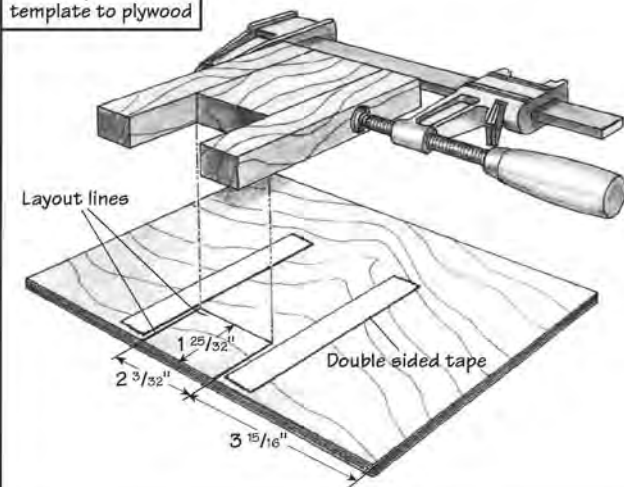

FIG. 4

Rout template cutout

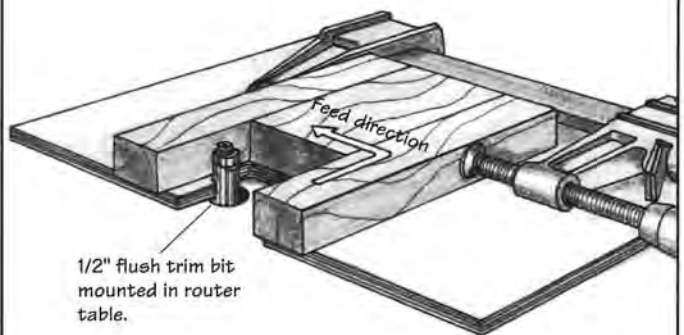
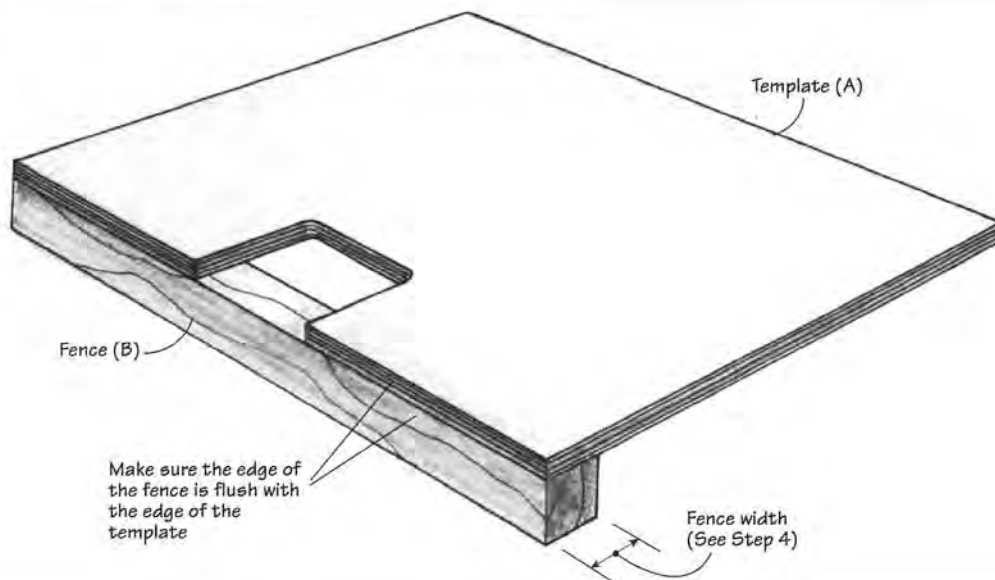

FIG. 5

Glue fence to template



Template Cutout

2 Attach the primary template to your Baltic birch plywood using double-sided tape. To help in aligning the primary template, mark layout lines on your plywood as shown in Fig. 3. Your INCRE GAUGE can be very helpful in accurately placing these layout lines.

3 Install a $\frac{1}{2}$ " flush trim bit in your router table and, taking small scallop-shaped bites, rout out the plywood cutout. You'll want to rout out the majority of the interior waste first, then with the bearing on the flush trim bit riding on the primary template, rout the perimeter. Fig. 4.

4 Glue the $\frac{3}{4}$ " x $\frac{3}{4}$ " x 10" fence (B) to your plywood template. Make sure that the edge of the fence is flush with the edge of the plywood, Fig. 5.

Note: If you are making this hinge mortising template for the lid design shown for the **Jewelry Box** on pages 138-148, you'll want the fence to be $\frac{9}{16}$ " wide instead of $\frac{3}{4}$ ".

5 The last step to produce your hinge mortising template is a test cut. Using double-sided tape, attach a piece of scrap stock to the top of your workbench. Allow the stock to overhang the edge of the workbench by about 1" or so. Now, using double-

sided tape, attach the mortising template to the stock with the fence on the template against the overhanging edge of the stock, Fig. 6. Install a $\frac{1}{2}$ " o.d. guide bushing in your router with a $\frac{1}{4}$ " straight bit and set the depth of cut to the thickness of the plywood template plus the thickness of one hinge leaf. See Fig. 6a. If you are making this template for mortising the INCRE wooden hinge and you are using $\frac{1}{4}$ " thick plywood as specified, then your depth of cut will be $\frac{7}{16}$ ".

Using a clockwise feed direction, rout out the perimeter of the hinge mortise with the guide bushing against the template cutout, then rout out the interior waste. Insert one of your

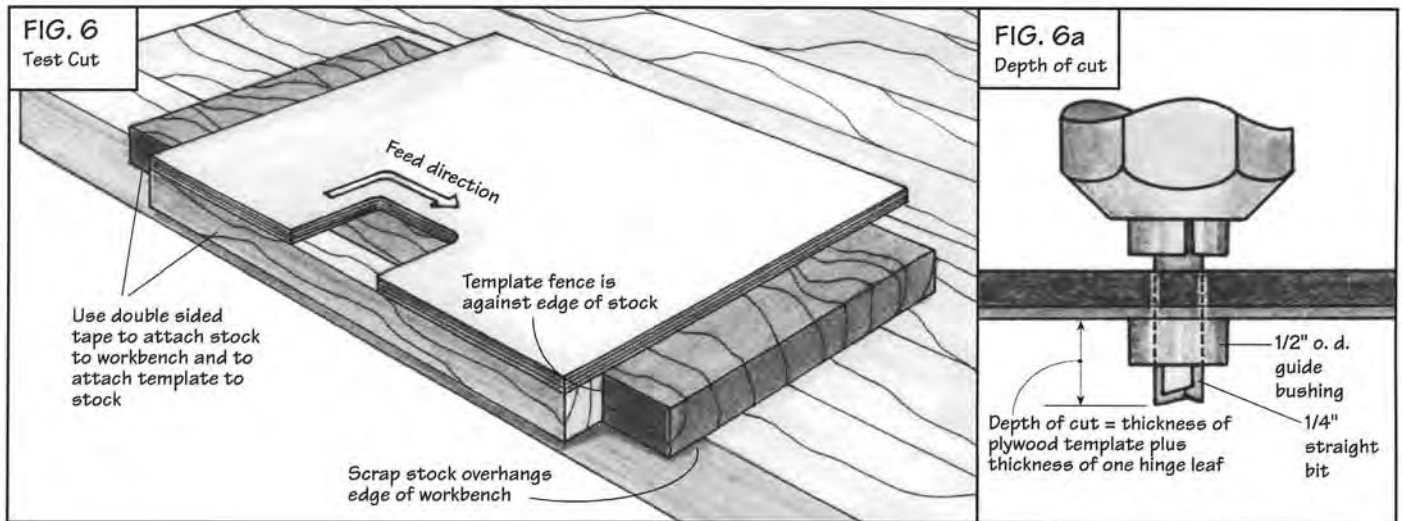

wooden hinges into the mortise you've cut to check the depth. The mortise depth should match the thickness of the hinge leaf. Increase or decrease the depth of cut as necessary. You'll notice after the test cut that a $\frac{3}{16}$ " deep dado has been cut across the fence, Fig. 7. The edges of this dado can be used when positioning the template for the cuts. Simply outline the hinge positions on your box and lid, then attach the template with double-sided tape, making sure to align the edges of the dado with the location marks. Rout the lid mortises first, then use the same template to rout the mortises for the box. To prevent splintering when routing the box mortises, use a strong double-sided tape (see Glossary) to attach a backing board to the inside face of the box back.

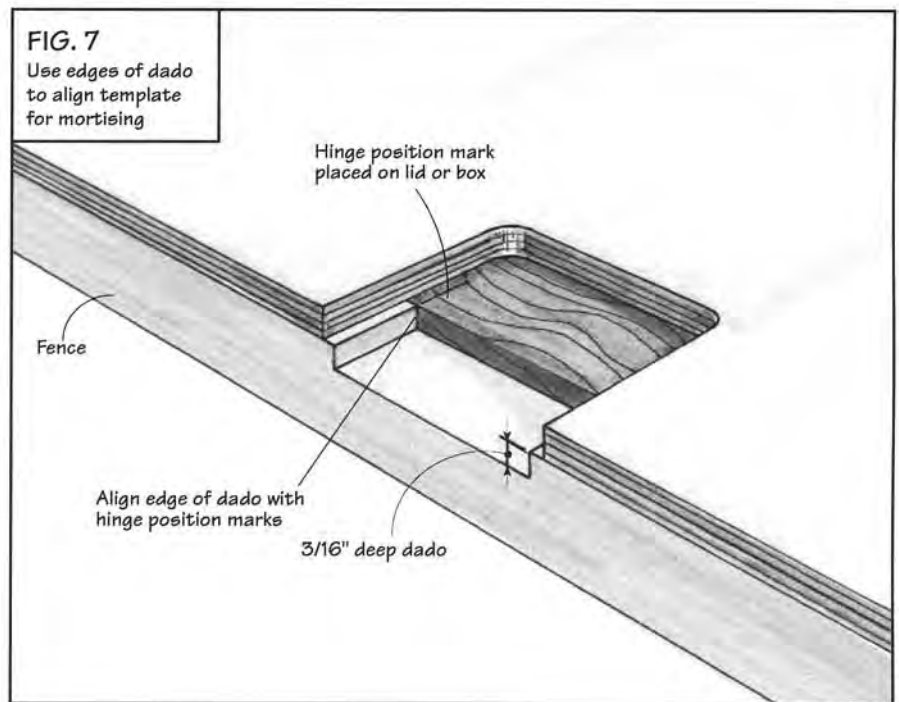
**TIP**

This same mortising template can be used to rout the mortises for the lift handles described for the **Trinket Box** (pages 132-136) and the **Jewelry Box** (pages 138-148). Make the lift handle first and then outline its position centered on the length of your box lid. Align the left hand edge of the dado on the mortising template with the left hand position mark and rout out the waste, then move the template to align the right hand edge of the dado with the right hand position mark and cut again.

A Final Note

The mortise left by this mortising template will have rounded corners with a $\frac{1}{8}$ " radius. You can chisel them square if you like, but I find it much easier to round the corners of the hinges instead. To do this, I sand three intersecting flat spots on the corner of the hinge (see Fig. 8), rather than trying to truly "round" the corner.

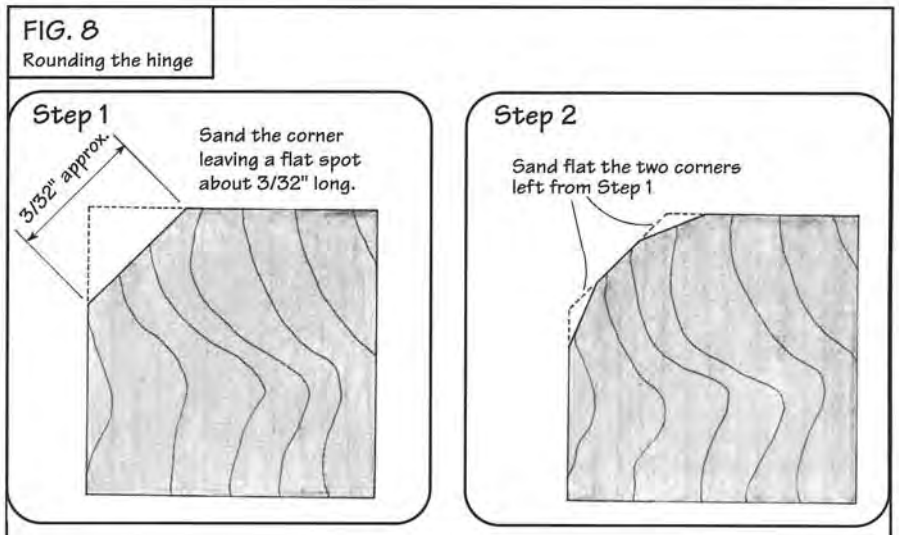

Vertical Holding/Tenoning Jig

Several of the box lids in this book feature raised panel cuts. These angled cuts add visual interest to an otherwise rectangular box design. Of the many methods for cutting raised panels, the technique I prefer uses what is commonly known as a tenoning jig to hold the lid panel perpendicular to the table saw surface, see Fig. 1.

The tenoning jig is often used to hold long stock on end when cutting tenons at the table saw. The jig usually has a miter bar attached to its base to guide the stock through the cut, and the position of the vertical portion of the jig can be adjusted closer to or farther away from the blade. It was not until I made my own tenoning jig using a right angle fixture, a Miter Slider, and some scrap plywood that I recognized the full value of this device. It is much more than just an aid in cutting tenons. In fact, I like to think of it as a vertical holding jig, a name which implies more than tenon cutting. With a few simple attachments, this fixture can be used to cut tenons, raised panels, and splined miters. Following the plans, I'll detail the technique I use when making the raised panel cuts for the boxes in this book.

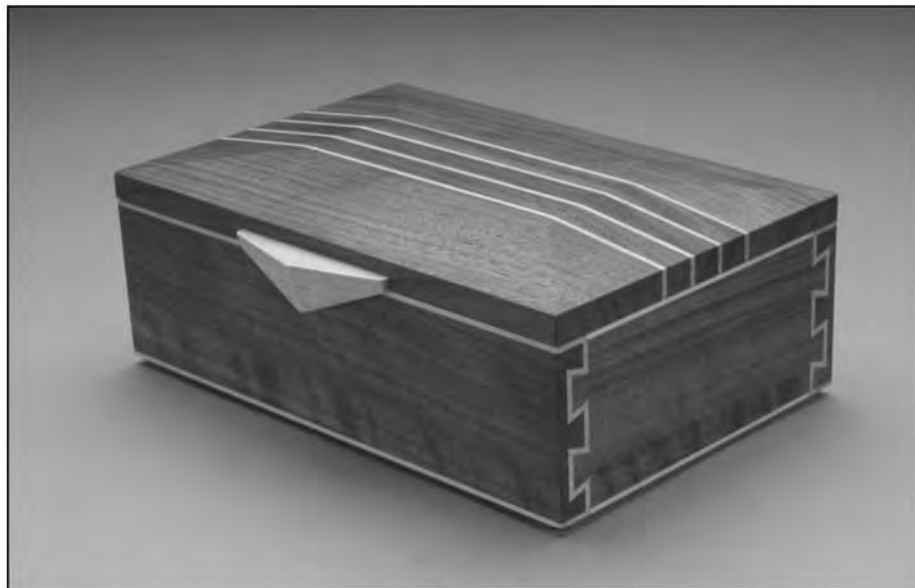

The raised panel cuts on the Trinket Box shown here were made using the vertical holding/tenoning jig.

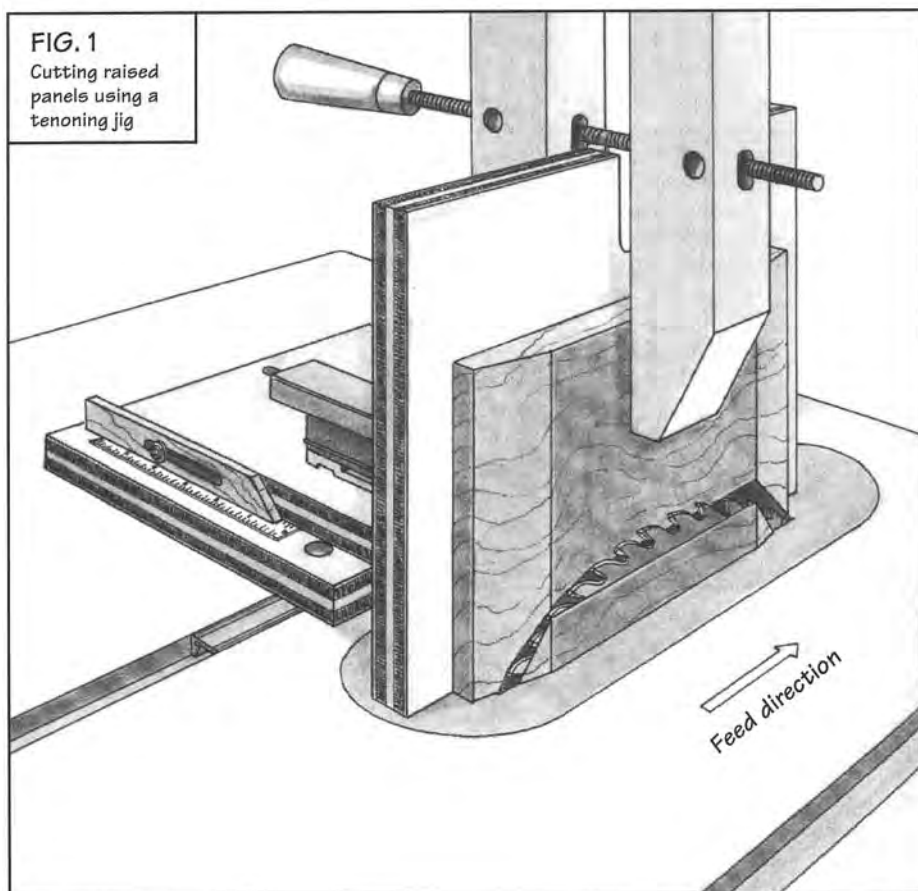

SEE ALSO

Decorative Playing Card Box	119
Decorative Domino Box	129
Trinket Box	132

Materials List	T	W	L	Material
A Base	3/4"	9"	9"	Plywood
B Top	3/4"	7"	9"	Plywood
C Runners	1/2"	1/2"	9"	Hardwood or plywood
D Scale marker	3/4"	5"	6-1/2"*	Hardwood
E Face plate	3/4"	9"	11"	Plywood

*Oversize blank, see Step 3.

Hardware Required

- (1) INCR A Right Angle Fixture
- (1) INCR A Miter Slider and mounting hardware
- (1) 3/8"-16 x 1 1/2" carriage bolt
- (1) 3/8" flat washer
- (1) 3/8"-16 T-knob
- (2) #8 x 1" pan head phillips wood screw
- (7) #8 x 3/4" pan head phillips wood screw
- (1) 6" scale

Required Bits

- 1/4" straight bit
- 3/8" straight bit
- 1/2" straight bit

Exploded view

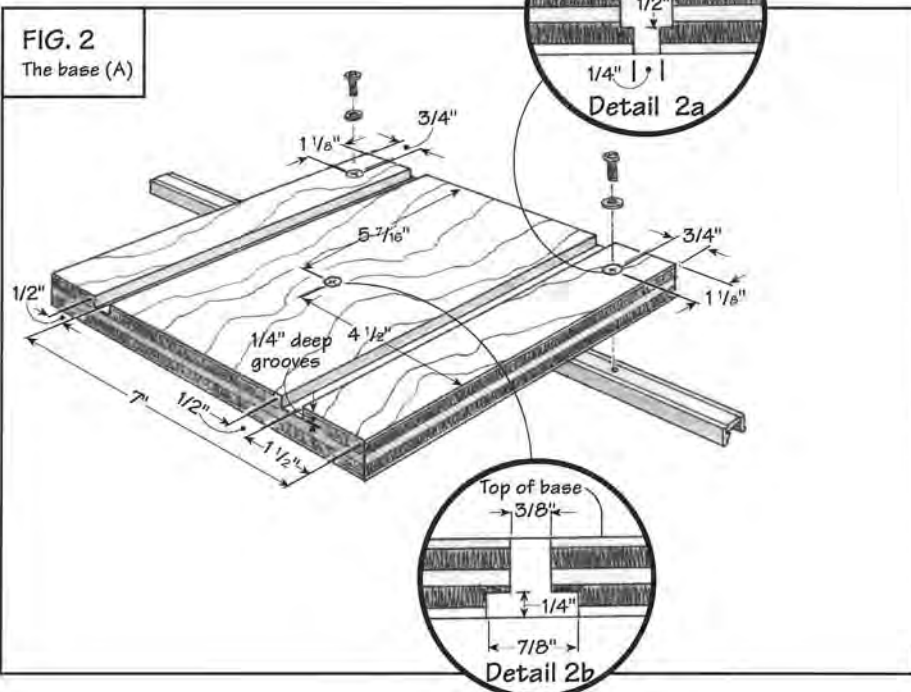
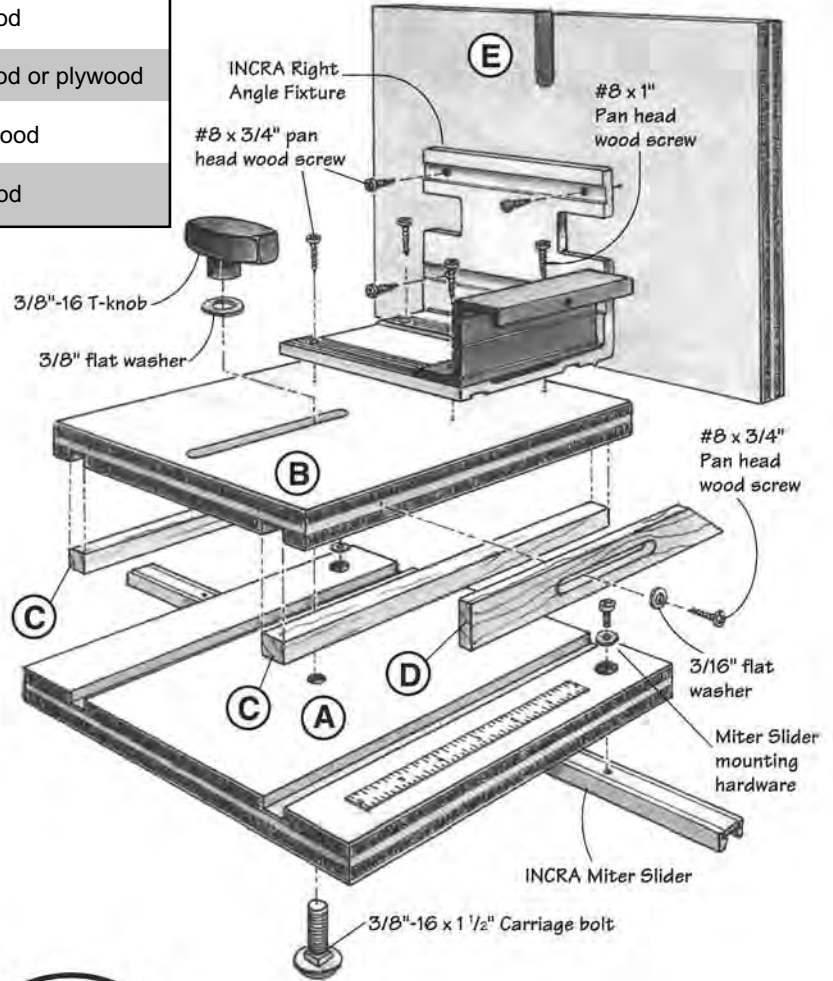

1 At the table saw, cut the plywood base (A) and top (B) to the indicated dimensions. Install a 1/2" straight bit in your router table and set the depth of cut to 1/4". "Zero" the fence to the edge of the bit and slide the scale to read 0" under the cursor. Set your INCR A JIG to 1 1/2" and cut the first groove on the base (A). To avoid splintering, cut with the grain of the top ply. Now set your INCR A JIG to 7" and, with the same edge of the base against the fence, cut the second groove, Fig. 2. At your drill press, drill the various hole/counterbore combinations shown in Details 2a and 2b. Your INCR A GAUGE is "Taylor" made for laying out the drill centers. Adjust the INCR A Miter Slider to fit the left hand miter slot at your table saw, then, using the supplied hardware, attach the Miter Slider to the base.

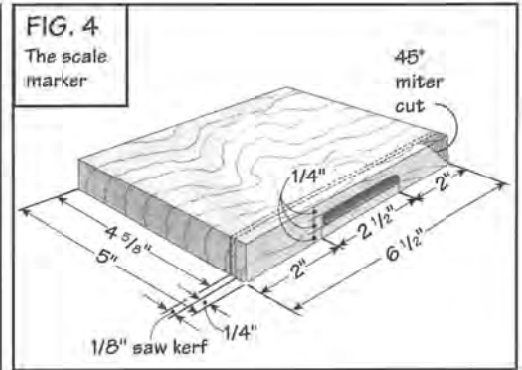
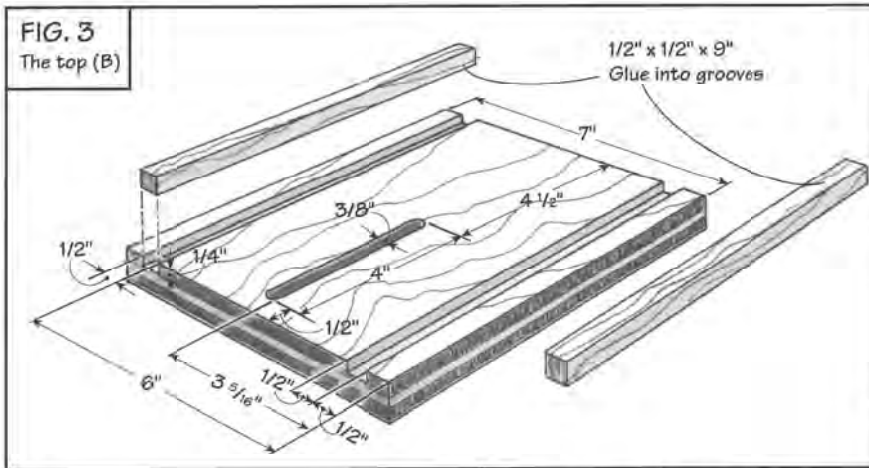

2 Cut the grooves for the top (B), again using the $\frac{1}{2}$ " straight bit and a $\frac{1}{4}$ " depth of cut. Set your INCRA JIG to $\frac{1}{2}$ " to cut the first groove (with the grain of the top ply). Then, with the same edge of the top against the fence, move your INCRA JIG to 6" and cut the second groove. Remove the $\frac{1}{2}$ " straight bit and install a $\frac{3}{8}$ " straight bit. "Zero" the fence to the edge of your bit and slide the scale to read 0" under the cursor. Set up infeed and outfeed INCRA Stops to cut the stopped groove shown in Fig. 3. Use the dimensions shown to set the stop positions as described on pages 32-33. The fence to bit distance will be set to $3 \frac{5}{16}$ " before making the cuts. Use several light passes, increasing the depth of cut after each pass to cut through the thickness of the top. **Caution:** Make sure to use a rubber soled push block and keep the push block clear of the area of the through cut.

Now, cut the two $\frac{1}{2}$ " x $\frac{1}{2}$ " x 9" wooden runners and glue into the grooves cut in the top.

3 To make the scale marker, cut a stopped groove on the edge of a $\frac{3}{4}$ " x 5" wide x $6 \frac{1}{2}$ " long piece of hardwood. Again, use the dimensions shown in Fig. 4 and the technique described on pages 32-33 to set up the

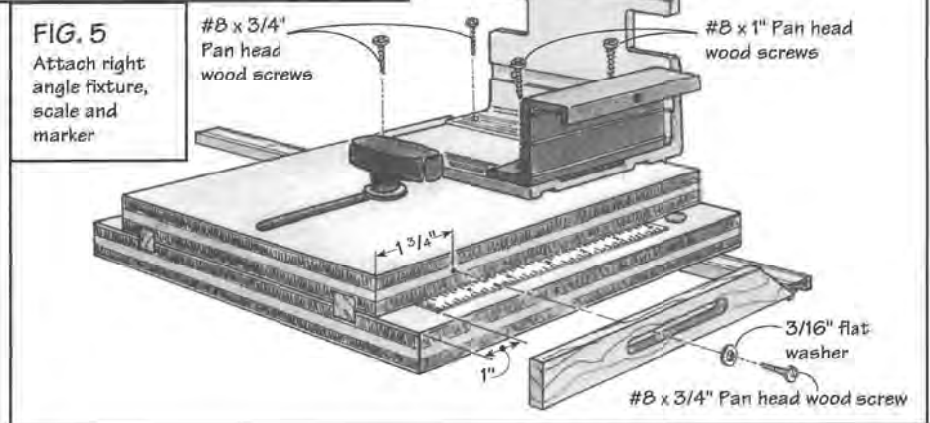

infeed and outfeed stops. Using a $\frac{1}{4}$ " straight bit with a $\frac{3}{16}$ " depth of cut and a $\frac{1}{4}$ " fence to bit distance, cut the groove. Increase the depth of cut to $\frac{5}{16}$ " and repeat the cut. At the table saw, set the fence to blade distance at $4 \frac{5}{8}$ " and rip the stock with the groove facing away from the fence. This will yield the $\frac{1}{4}$ " thick scale marker. Miter cut the end as shown in the drawing.

4 Lock the top to the base using the carriage bolt, washer, and T-knob. Then, using the hardware as shown in Fig 5, attach the INCRA Right Angle Fixture to the top of your vertical holding jig. Use double-sided tape to attach a 6" scale to the base, then attach the scale marker to the edge of the top.

5 Fig. 6 shows three faceplates that can be attached to the vertical face of the right angle fixture for various cutting operations. Each of the faceplates is made from a piece of $\frac{3}{4}$ " x 9" x 11" plywood with hardwood attachments. Use (4) #8 x $\frac{3}{4}$ " wood screws through the back of the right angle fixture to attach the faceplates. Be sure to check the faceplate for squareness to your table saw surface before using the jig. Adjust by placing paper shims or masking tape between the right angle fixture and the back of the faceplate. The faceplate should also be adjusted parallel to the saw blade. Loosen the Miter Slider mounting screws to adjust for parallel.

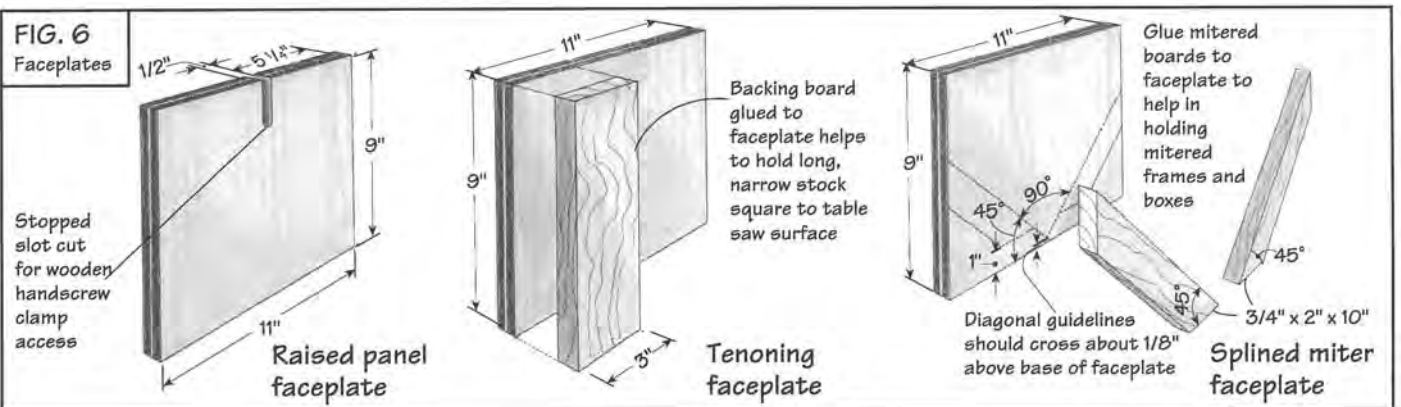

Cutting Raised Panels with Your Vertical Holding Jig

1 Attach the raised panel faceplate shown in Fig. 6 and, with the Miter Slider on your vertical holding jig engaged in the left hand miter slot* in your table saw, loosen the T-knob and slide the top half of the jig up to meet the saw blade. At this position, slide your scale marker to read 0" on the scale, Fig. 1. Now, as you move the faceplate away from the blade, the scale marker will give a direct readout of the distance from the faceplate to the blade.

* If your table saw blade tilts to the left, move the right angle fixture handle and scale to the opposite side of the jig and use the right hand miter slot.

2 For lid panels 6" x 9" or larger, raise the sawblade 2 1/2" and tilt the blade 8° from vertical, Fig. 2. For small lids like the **Playing Card Box** on pages 119-122 or the **Domino Box** on

pages 129-131, never raise the blade more than half of the smaller of the length or width dimension. I raised the blade only about 1 1/4" for each of these projects.

3 Clamp the lid panel to the face of the vertical holding fixture using a wooden handscrew clamp as shown in Fig. 3. To avoid tearout, you'll always want to cut the ends of the panel first (across the grain), so place the end grain of the lid against the table. Now loosen the T-knob on the fixture and slide the faceplate until the box lid contacts the saw blade. Note the scale marker position on the scale.

Caution: Make sure that the wooden handscrew clamp will clear the blade before making any cuts.

4 Advance the top half of the vertical holding jig 1/8" closer to the saw blade. Lock the T-knob

and make the cut. After the cut, examine the lid panel. If you desire a wider cut, advance the upper half of the jig 1/32" closer to the blade and repeat the cut. Continue this trial and error process until you achieve the cut width you desire.

5 Now rotate the lid panel end for end and cut the opposite end of your lid panel. Then rotate the panel to make the remaining side cuts, Fig. 4.

Note: If your raised panel cuts are not meeting at the corners of your box lid, first check to make sure the faceplate is parallel to the saw blade. To adjust for parallel, loosen the Miter Slider mounting screws and correct the faceplate angle, then re-tighten the mounting screws. If this does not correct the problem, check to make sure your blade is parallel to the miter slot in your table saw.

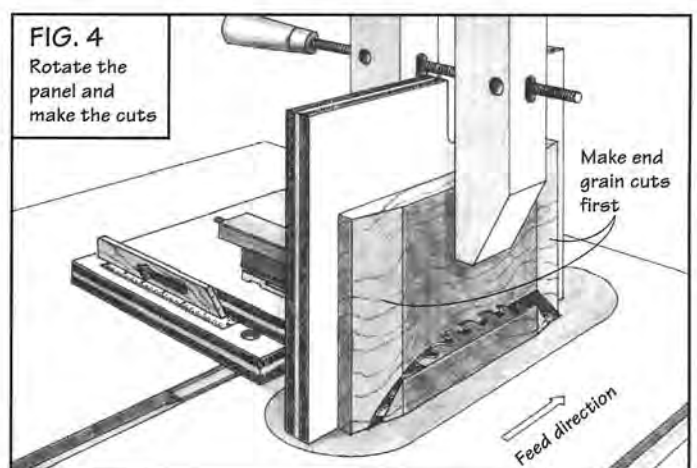
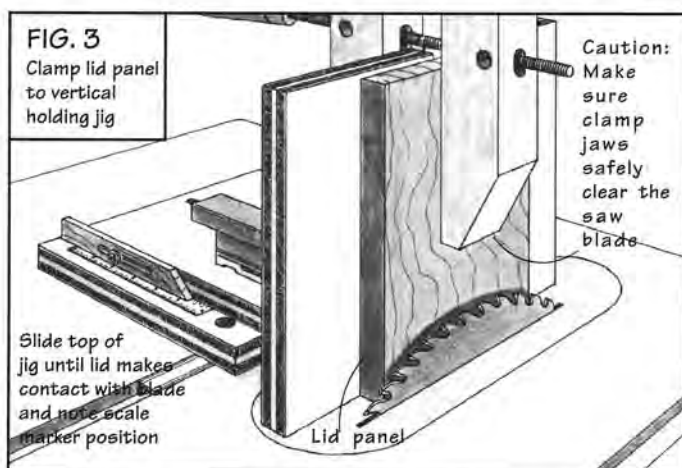
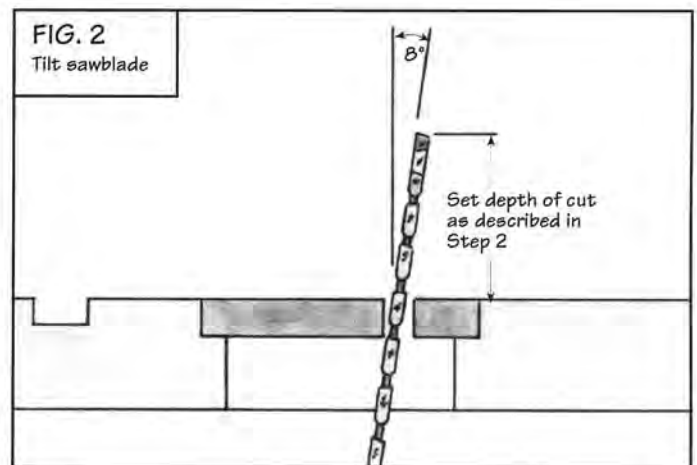
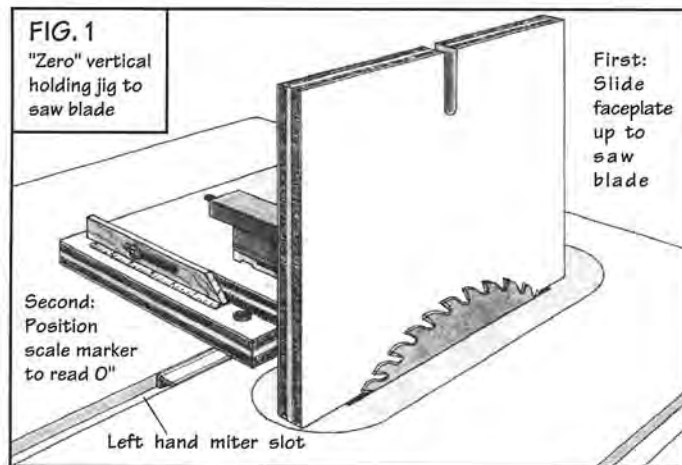

IV

INCRA

JOINERY

In the few years since its first appearance in woodworking shops around the world, INCRA JIG has quickly established itself as one of the finest and most versatile joinery systems available. With it, box joints can be cut with any combination of pin and groove spacing imaginable. Half-blind and through dovetails can be quickly and accurately produced using the preprinted INCRA templates. By customizing the patterns as described on page 17 of the Master Reference Guide, you can create an unlimited number of joint patterns. Indeed, with joinery regarded by many as the measure of a woodworker's skill, it is not surprising that a tool offering such flexibility should do well. But box joints, half-blind and through dovetails were just the beginning.

Along with the traditional joinery, INCRA JIG also ushered in a new genre of woodworking joints, the decorative double joinery. The beautiful INCRA Double Dovetail and the spectacular INCRA Double-Double Box Joint were first, and as you'll see in the sections to follow, they'll not be the last. Two of the four new joints to follow, the Double-Double Through Dovetail and the Cornerpost Eagletail, are made using the templates included with this book. The other two decorative joints, the Cornerpost Dovetail and the Cornerpost Double Dovetail, can be made with any INCRA dovetail or double dovetail template using the techniques described. You'll also read about a new approach to making many of these double joints that doesn't require a thickness planer.

Included with each new joint discussion is a helpful chart and paragraph headed "Formula for Success". Here you'll find suggested templates, stock thickness, stock width, and the appropriate "center out" to use in the centering process. These suggestions, when used with the step-by-step descriptions for cutting the joints, will have you well on your way to creating your own INCRA masterpiece.

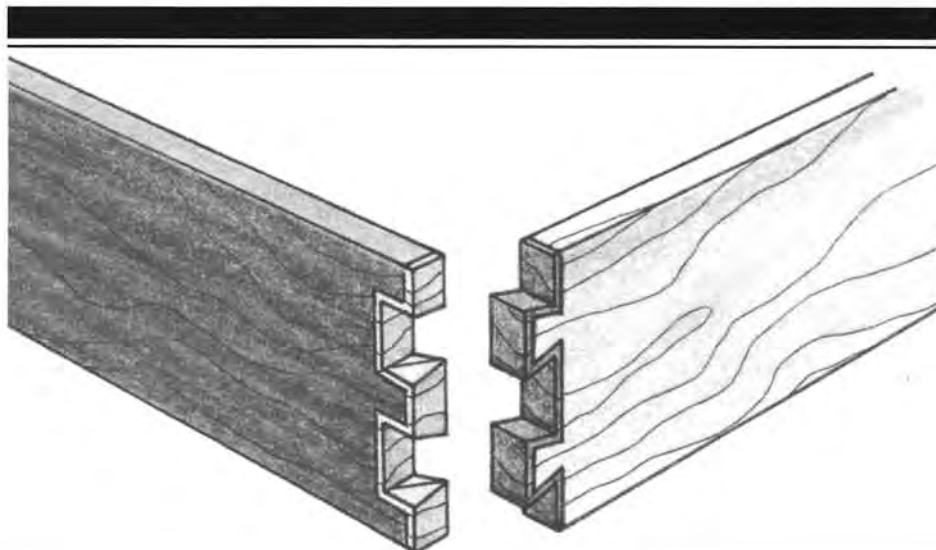

INCRA® Double Joinery Without a Thickness Planer

With the exception of the Double-Double Through Dovetail shown on pages 55-61, all of the INCRA double joints can be made without a thickness planer. In fact, having made several hundred of these double joints, it is the method of choice for me. Follow along as I describe the basic principle, then if you wish to try out the technique on a specific example, see the **Decorative Playing Card Box** on pages 119-122 and the **Trinket Box** on pages 132-136.

The method described in *The Original INCRA JIG Handbook and Templates* requires the trim section (referred to in the Handbook as the "center piece") to be planed to a thickness equal to $\frac{3}{32}$ " greater than the depth of cut. This is true for all of the INCRA double joinery with the exception of template IDDF from the INCRA Master Template Library, which has a trim section thickness equal to the depth of cut plus $\frac{1}{8}$ ". After gluing the trim sections to the mating tail or box joint section, you are left with a piece that resembles one of the drawings in Fig. 1. But what if you have no thickness planer? It was quite by accident that I discovered the answer.

I was working on a series of 13 jewelry boxes featuring the Double-Double Box Joint and was running short of time to complete them. In my haste, I cut the trim section pieces to length and



Nearly all of the INCRA double joints can be made without using a thickness planer, including the INCRA Double-Double Box Joint and the INCRA Double Dovetail shown here.

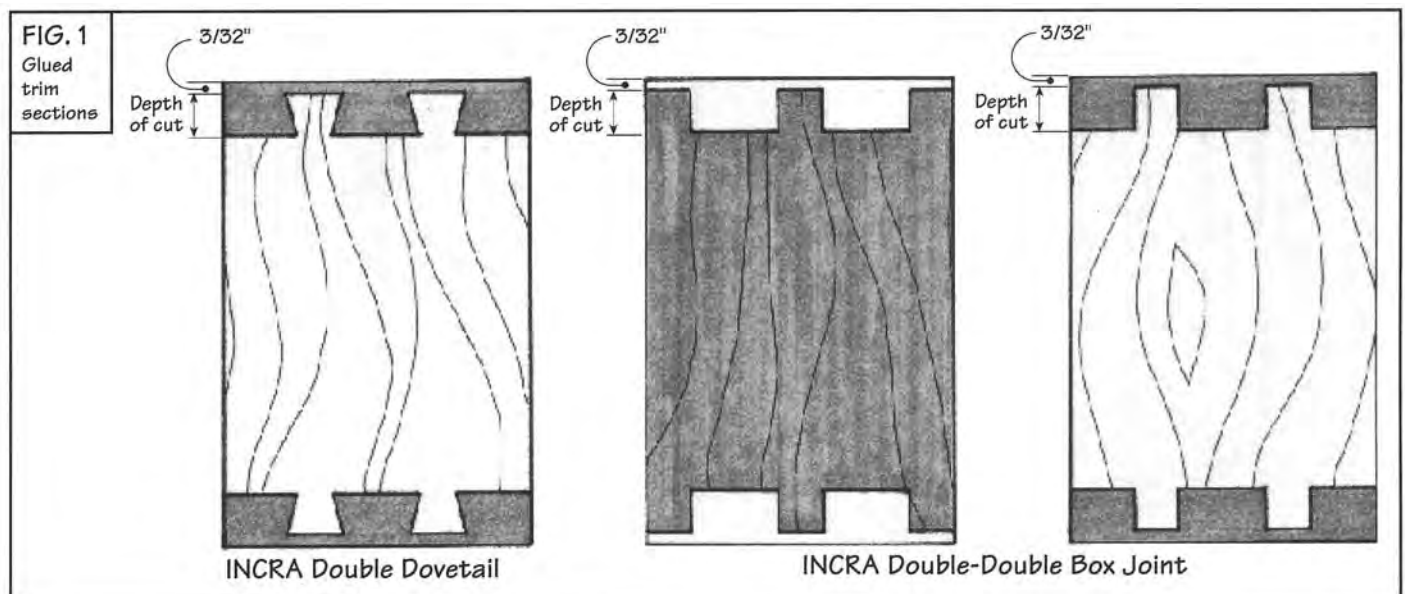

width and made the initial grooves along their length at the router table. It was not until I began gluing the trim sections to the mating box joint sections that I discovered my mistake. I had forgotten to thickness plane the trim section stock before cutting the grooves. All of my trim section pieces were $\frac{3}{4}$ " thick! I had no reserve stock, and the thought of the time and money wasted to remake the pieces was too much to bear. This is the solution I came up with:

1 Glue the $\frac{3}{4}$ " thick trim section pieces to the box sides as shown in Fig. 2. Allow the glue to set for about one hour then belt sand the trim sections flush with the faces of the box sides. With a sharp pencil place a mark on the trim section $\frac{3}{32}$ " from the outermost glue joint, see detail Fig. 2.

2 Now at the table saw using a sliding crosscut box as shown in Fig. 3, or a miter gauge with an auxiliary fence as shown in Fig. 4, cut the ends of each piece to the mark. Sneak up on each cut so that you don't cut inside the mark. When you are finished cutting both ends of each piece they should look like the examples shown in Fig. 1.

3 Using the technique above, you can simply buy $\frac{1}{2}$ " or $\frac{3}{8}$ " thick stock for the box sides (I use $\frac{1}{2}$ " stock for most boxes featuring the INCRA Double Dovetail, and $\frac{3}{8}$ " stock for the INCRA Double-Double Box Joint). For the trim sections, any contrasting stock about $\frac{3}{4}$ " thick will do.

FIG. 2
Mark trim section

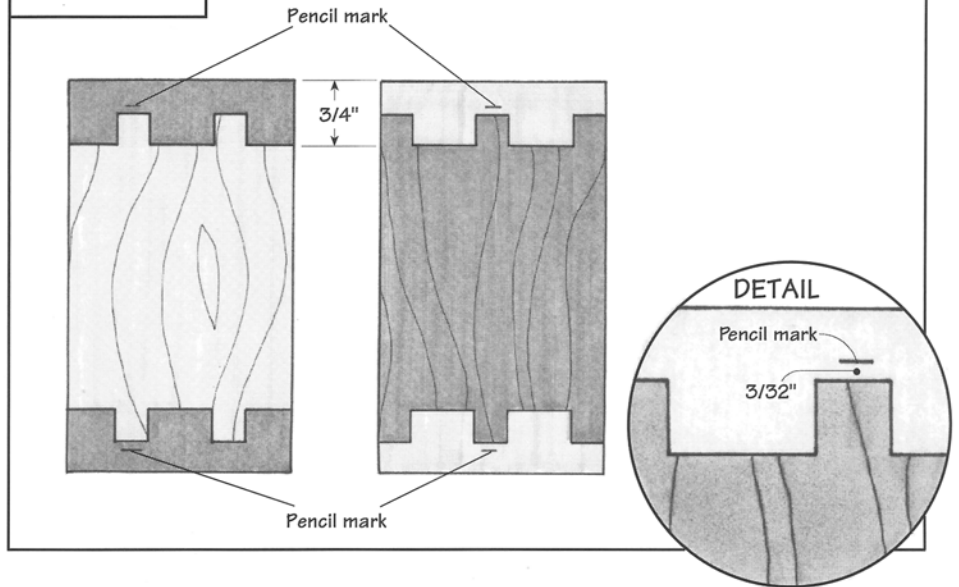

FIG. 3
Cut off ends -
Crosscut box

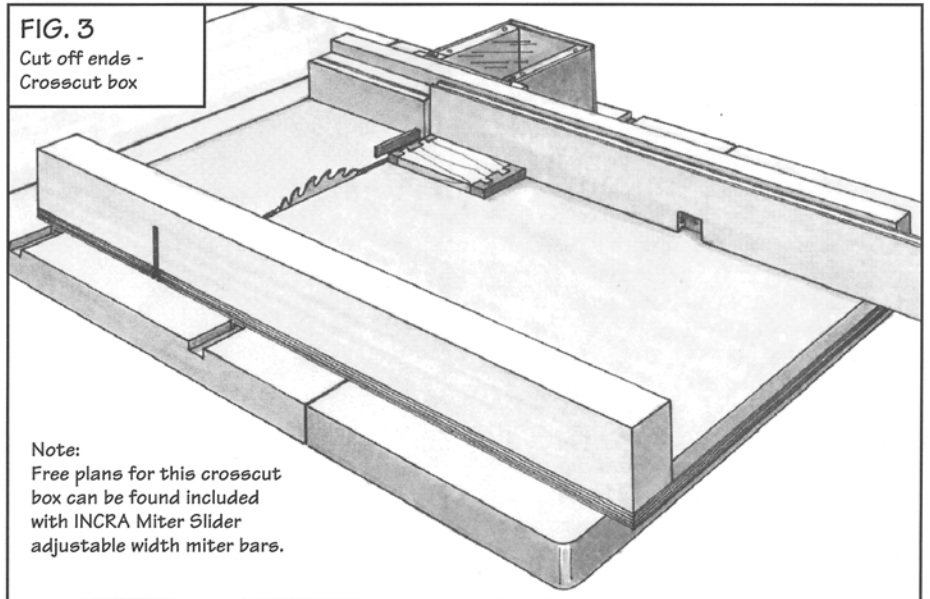
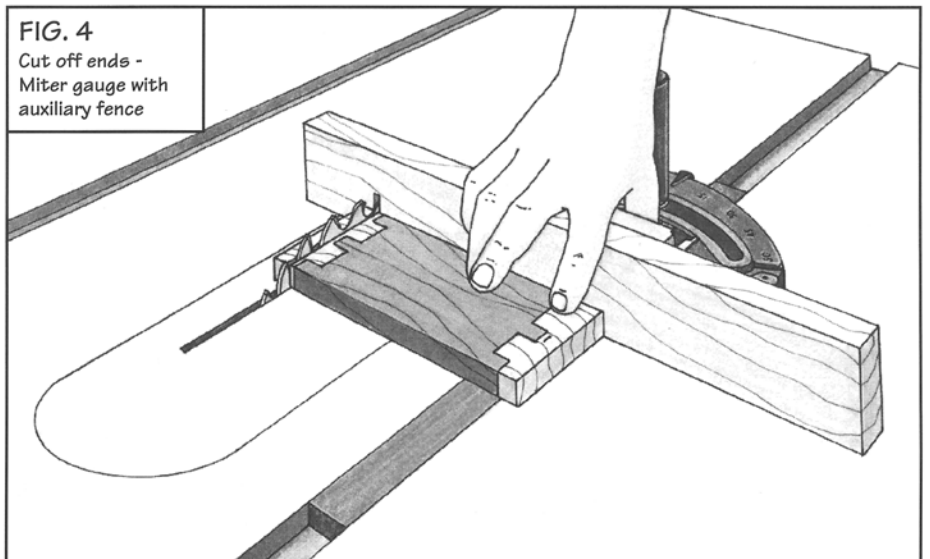

FIG. 4
Cut off ends -
Miter gauge with
auxiliary fence



INCRA® Double-Double Through Dovetail™



The Double-Double Through Dovetail is the first in the collection of INCRA double joinery to require the use of two router bits - a dovetail and a straight bit. In this respect, it may be deemed the most complex of the decorative joints. Once you have mastered it, you should consider yourself a certified INCRA "PRO"! In many respects, this joint is similar to the Double-Double Box Joint. If you have not yet made the Double-Double Box Joint, it would be a good idea to review the discussion of this joint in the Master Reference Guide. Also review the section of the video covering through dovetails. Throughout this section, you will be using the Double-Double Through Dovetail templates labeled **ONE** and **TWO** that are supplied with this book. You should also refer to the full-sized plans for this joint on page 61 at the end of this section.

Let's begin by analyzing the exploded view of the Double-Double Through Dovetail in Fig. 1 and Fig. 2. As you can see, the joinery begins with the addition of a trim section to the ends of the two pieces in the joint. The piece on the left half of each drawing is joined to a trim section with variably spaced box joints cut with a straight bit. The piece on the right half of each drawing is joined to a trim section with a variably spaced dovetail joint cut with the dovetail bit.

In the final series of cuts shown in Fig. 2, a dovetail bit is used to join together the two sides. The "D" cuts are very straightforward, as shown in Fig. 14 on page 59. The "C" cuts are made as shown in Fig. 16. This is also shown in The Complete INCRA JIG Video in the section describing pin cuts for through dovetails.

Now that you've seen the essence of this fascinating new joint, let's look at it step-by-step.

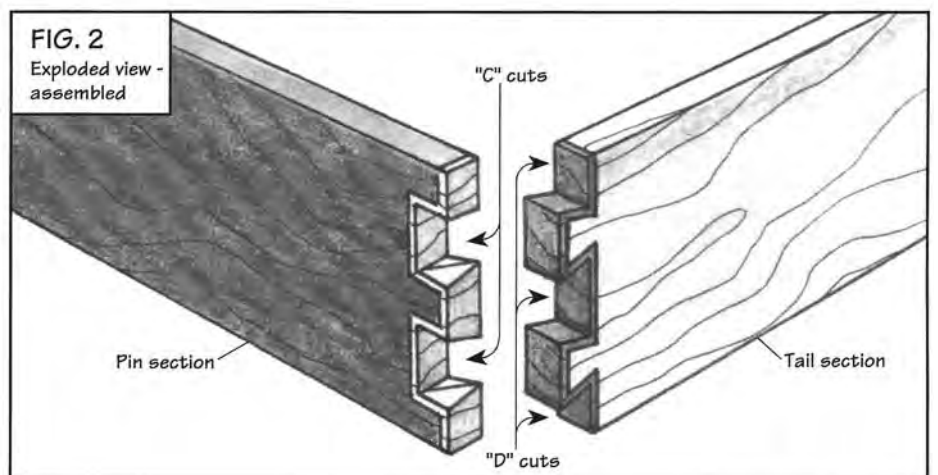
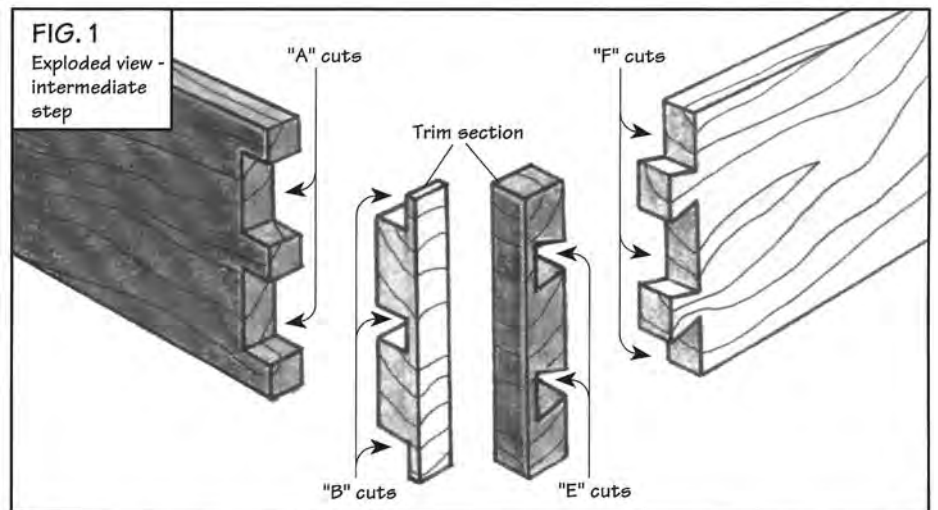

Required Bits

1/2" - 14° dovetail

3/8" straight bit

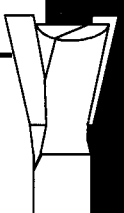

SEE ALSO	
Centering	22
Boxes Made to Order	27

Design Tip

Color Arrangement:

In Fig. 2 on page 55, the light dovetail side of the piece has a dark trim section while the dark box jointed side has a light trim section. This is a pleasing arrangement, but don't limit yourself. With four pieces of wood in the corner joint, each could be a different color.

Or, you might try making all four sides blond and the two trim sections each a different color.

Use your imagination!

Stock Dimensions

You will need seven pieces of wood to make a box with this corner joint. Four pieces for the front/back and sides, one piece for the box joint trim section, one piece for the dovetail trim section, and one piece for the "centering" process. Here are a few rules regarding the width, thickness, and length of the pieces:

WIDTH

All seven pieces must be of equal width (see the "Formula for Success" chart on page 60 for a few suggested stock widths and corresponding "center" cuts to use when making this joint)

THICKNESS

Front/Back and Sides - These pieces must be equal in thickness to the depth of cut for your dovetail bit.

Box joint trim section - $\frac{3}{4}$ "

Dovetail trim section - $\frac{3}{4}$ "

"Centering" board - $\frac{3}{4}$ "

LENGTH

Front/Back and Sides - The front/back pieces should be of equal length. The side pieces should be of equal length.

Note: For more information on cutting the front/back and side pieces to length to produce a specific size box when using the Double-Double Through Dovetail joint, see page 29.

Box joint trim section - 6"

Dovetail trim section - 6"

"Centering" board - 5"

Determine Dovetail Bit Depth of Cut

When you begin actually cutting the wood for this joint, you will start with the straight bit cuts ("A" and "B" cuts), however, the depth of cut for the straight bit must match the depth of cut used with the dovetail bit in cutting the "C" through "F" cuts. Since every dovetail bit produces a slightly different depth of cut for a given spacing, it is very important that you determine the depth of cut for your dovetail bit before installing the straight bit for the "A" and "B" cuts. It is also important to know your dovetail bit depth of cut first because the stock thickness for the Double-Double Through Dovetail must be equal to the depth of cut.

To set the depth of cut, install a $\frac{1}{2}$ "-14° dovetail bit in your router table and set the bit depth using the method described on pages 2-3 of the Master Reference Guide. (Also shown here in Figs. 3 and 4.) For this method you will make two side by side dovetail cuts across the end grain of two boards clamped to your right angle fixture. (Fig. 3) The two cuts must be $\frac{13}{16}$ " apart and the bit must be partially recessed in the notch in your fence for the first cut.

Cut locations 2F and 3F on Template TWO are $\frac{13}{16}$ " apart if you would like to use it to help in setting the depth of cut. Remember: After making the two cuts, test the fit as shown in Fig. 4 and use the rule "Heighten to tighten, lower to loosen" to adjust the bit height. After adjusting, repeat the two cuts on the uncut ends of the two boards and again check the fit. Adjust and recut as necessary until you achieve a close fit between the two pieces. Mark the cuts with the good fit. These marked cuts on the scrap boards can now be used as a height gauge for setting your straight bit depth of cut and later for resetting the dovetail bit depth of cut. The scrap can also be used as a thickness gauge when you plane down the stock for the sides of your box.

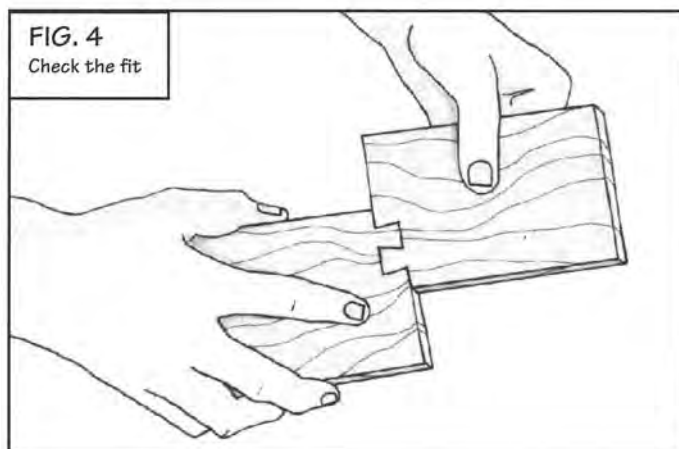
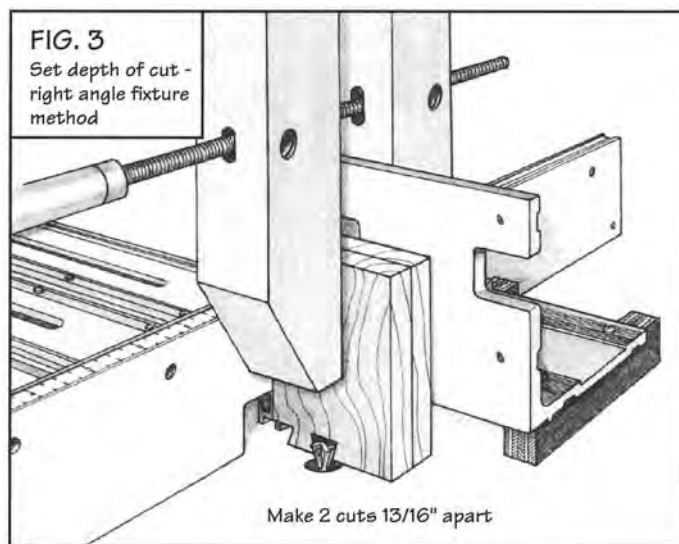

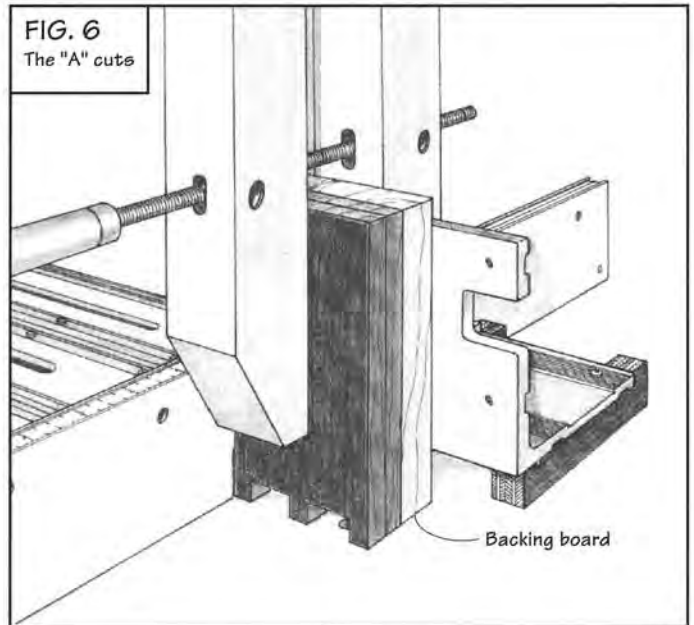
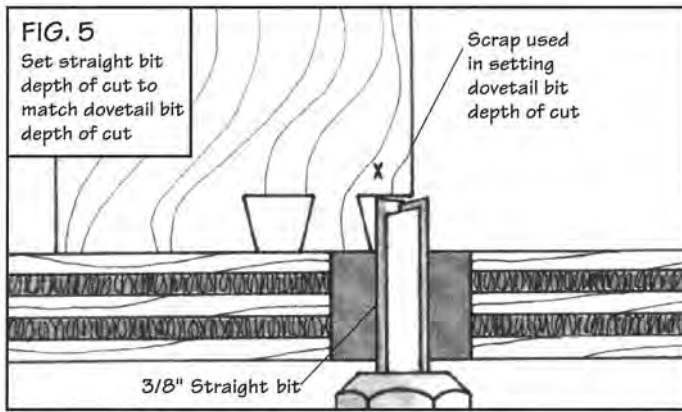

Cutting the Joint

1 Remove the dovetail bit and install a $\frac{3}{8}$ " straight bit in your router table. Set the straight bit depth of cut to match the depth of cut of the dovetail bit. Use the marked cut on one of the scrap pieces retained in setting the dovetail bit depth of cut as a gauge to help. Fig. 5.

2 Install Template ONE in your INCRA JIG with the arrow on the template pointing away from the fence. Depending on your stock width, lock your INCRA JIG to cut 8A or 3B and "center" using the centering board. (See the "Formula for Success" chart on page 60 for several suggested stock widths and the corresponding "center" cut.)

3 Clamp either the sides or the front/back pieces to the right angle fixture with a backing board as shown in Fig. 6 and make the "A" cuts. Before removing the pieces from the right angle fixture, mark the "fence" edge of the two pieces with a pencil. Now repeat the "A" cuts on the opposite ends of the boards, being sure to place the "fence" edge adjacent to the fence before clamping to the right angle fixture.

4 Make the mating "B" cuts along the length of the box joint trim section as shown in Fig. 7. Be sure to use a rubber soled push block for this operation. When making the cuts on the inside edge of the stock always start with a light $\frac{1}{32}$ " scoring pass and move to the final groove width in several side by side passes. On the outside edge of the board, start with a $\frac{1}{32}$ " pull-cut as described in "Rabbeting the Outside Edge" on page 9. Then work your way back to the "B" cut on the template in several light $\frac{1}{16}$ " pull-cut passes.

5 At the table saw, using a crosscut box or a miter gauge with an auxiliary fence, crosscut four pieces from the box joint trim section. See Fig. 8. Each piece should be about $\frac{1}{32}$ " longer than the thickness of the sides cut in Step 3 to allow for belt sanding flush in Step 11. Glue the trim pieces to the ends of the sides cut in Step 3 and set aside, Fig. 13.

6 Release the cam clamp and slide your INCRA JIG carriage to position the hairline cursor directly over the "Align" mark on Template ONE. Lock the cam clamp in place, then remove Template ONE. Slide Template TWO into the scale slot with the arrow on the template pointing away from the fence and position the template with the "Align" mark directly under the hairline cursor. This positions Template TWO so that the remaining cuts will be aligned with those on Template ONE.

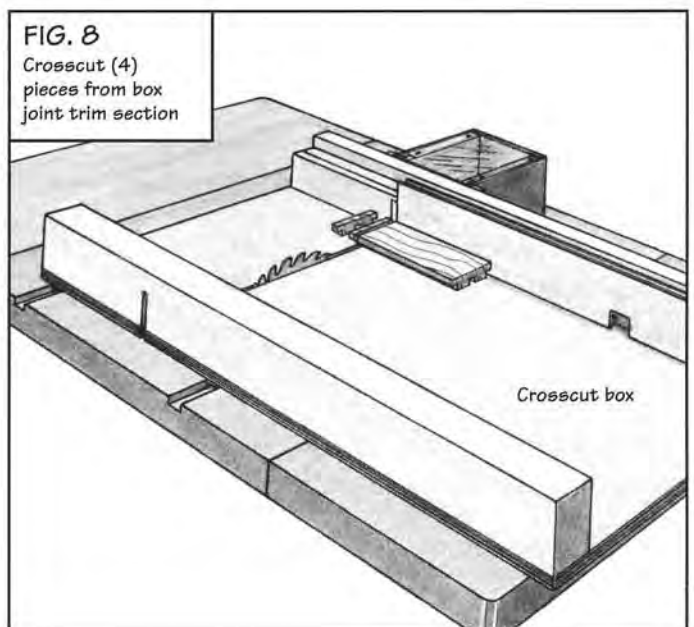
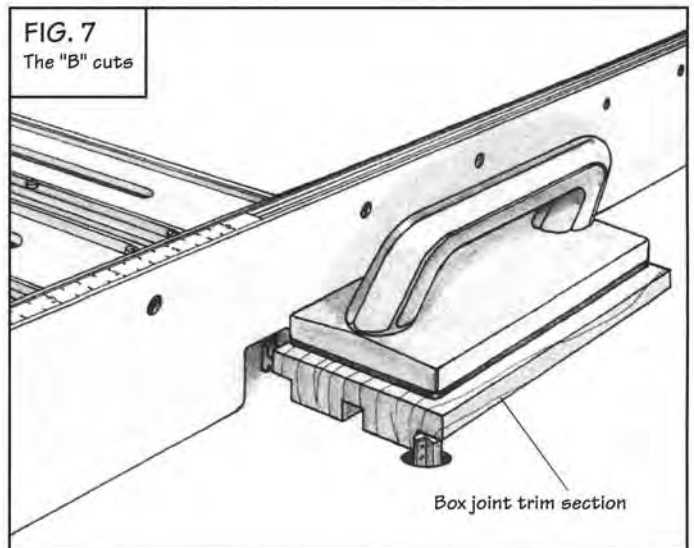

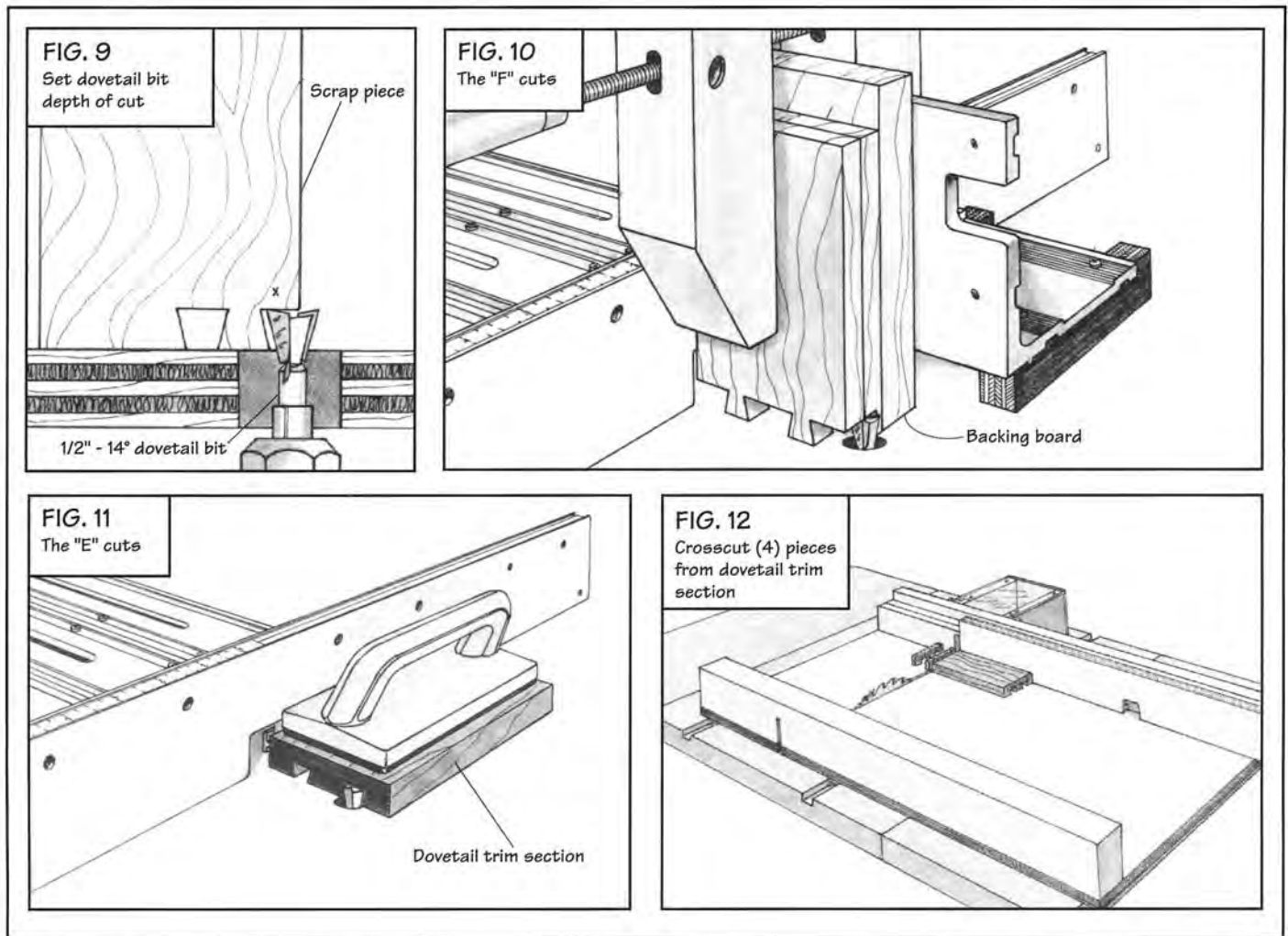

7 Remove the straight bit and re-install the 1/2" - 14° dovetail bit in the router table. Set the bit height again using the marked cut on one of the scrap pieces retained in setting the depth of cut earlier, Fig. 9.

8 Clamp the remaining two sides to the right angle fixture with a backing board as shown in Fig. 10 and make the "F" cuts. Before removing the boards from the right angle fixture, mark the "fence edge" of the pieces with a pencil. Now repeat the "F" cuts on the opposite ends of the boards making sure to place the "fence edge" adjacent to the fence before clamping to the right angle fixture.

9 Cut the mating "E" cuts along the entire length of the dovetail trim section as shown in Fig. 11. Be sure to use a rubber soled push block for this operation.

10 At the table saw, using a crosscut box or a miter gauge with an auxiliary fence, crosscut four pieces from the dovetail trim section. See Fig. 12. Each piece should be about 1/32" longer than the thickness of the sides or front/back pieces cut in Step 8. Glue the trim pieces to the ends of the sides cut in Step 8 and set aside, Fig. 13.

11 After the glue has set (allow about 1 hour), belt sand the trim pieces flush with the faces of the front/back and side pieces (all four). At the table saw cut off the ends of each piece to 3/32" from the outermost glue joint. See Fig. 13.

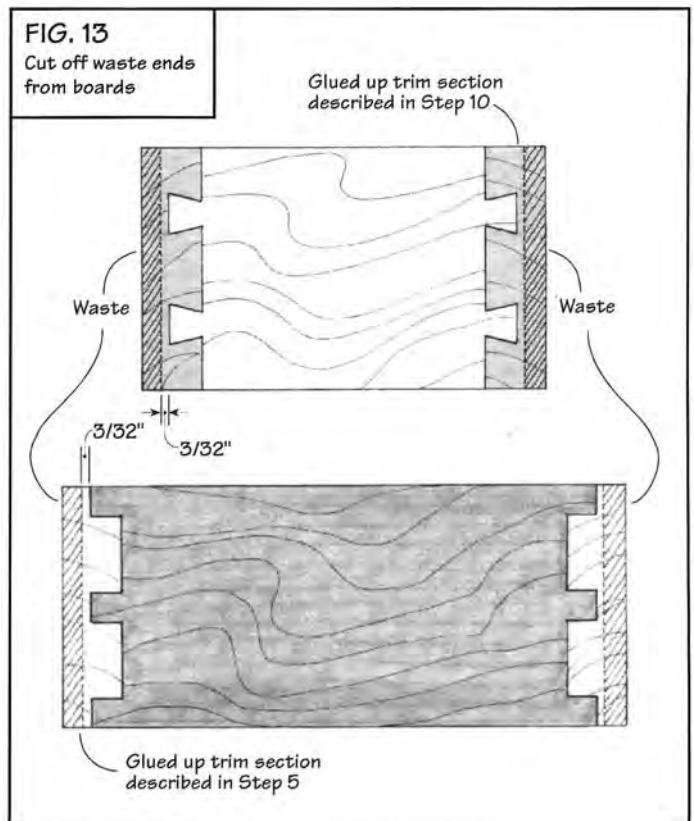

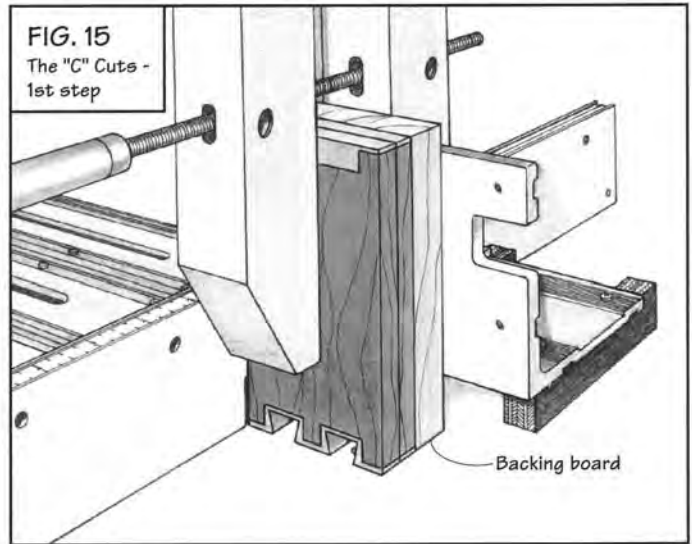
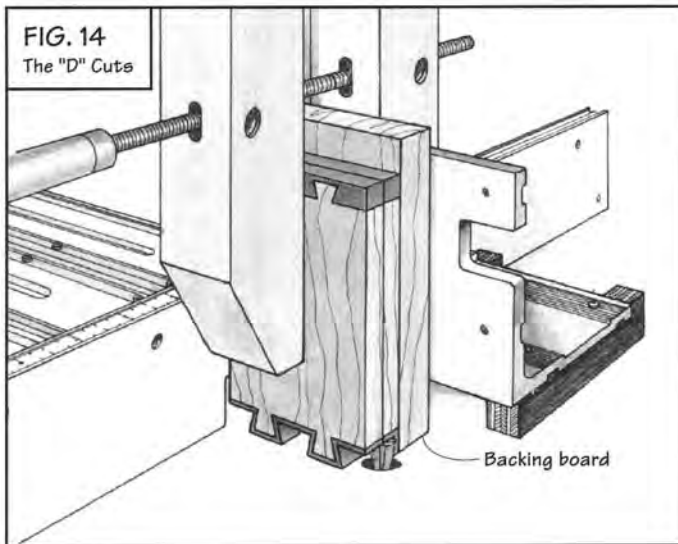

Now that you have added the trim pieces to all four front/back and side pieces, the "C" and "D" cuts will be used to cut a through dovetail.

The "D" cuts will be made on the tail pieces (the two dovetailed boards) and the "C" cuts will be used for the pins (the box jointed boards).

12 Place the dovetailed boards glued up in Step 10 on the right angle fixture with a backing board as shown in Fig. 14 and make the "D" cuts on both ends of the pieces. Be sure to place the "fence edge" of the boards adjacent to the fence before clamping to the right angle fixture.

13 Place the box jointed boards glued up in Step 5 on the right angle fixture with a backing board as shown in Fig. 15 and make the "C" cuts on both ends of the pieces. Be sure to place the "fence edge" of the boards adjacent to the fence before clamping to the right angle fixture.

14 Remove the box-jointed boards from the right angle fixture and, with the boards face down on the table, re-cut the "C" cuts as shown in Fig. 16. You'll need to set up an outfeed INCRA Stop to stop the cut before the arc of the dovetail bit touches the flat surface left by the cuts in Step 13. See Fig. 16a. The nylon stop screw on the INCRA stop will need to be in the lowest position and you'll need to cut the head of the screw off. At each "C" location on the template make the cuts on both ends of each board keeping the same face down on the table for all of the cuts.

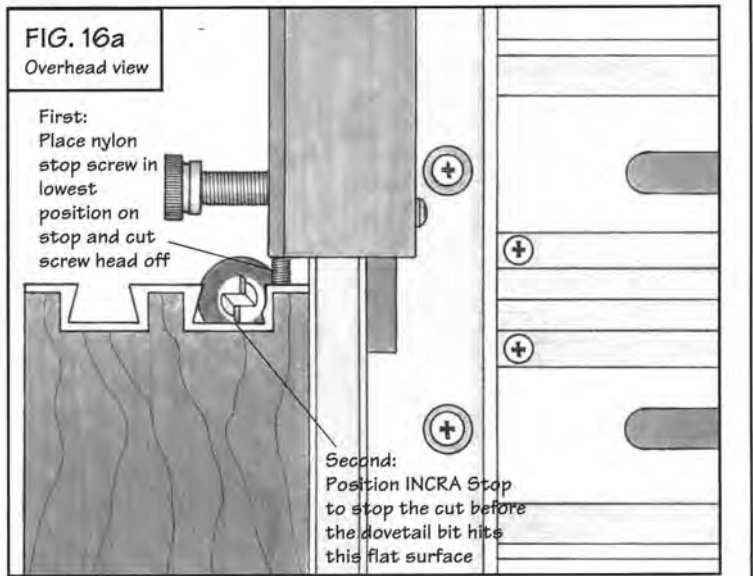
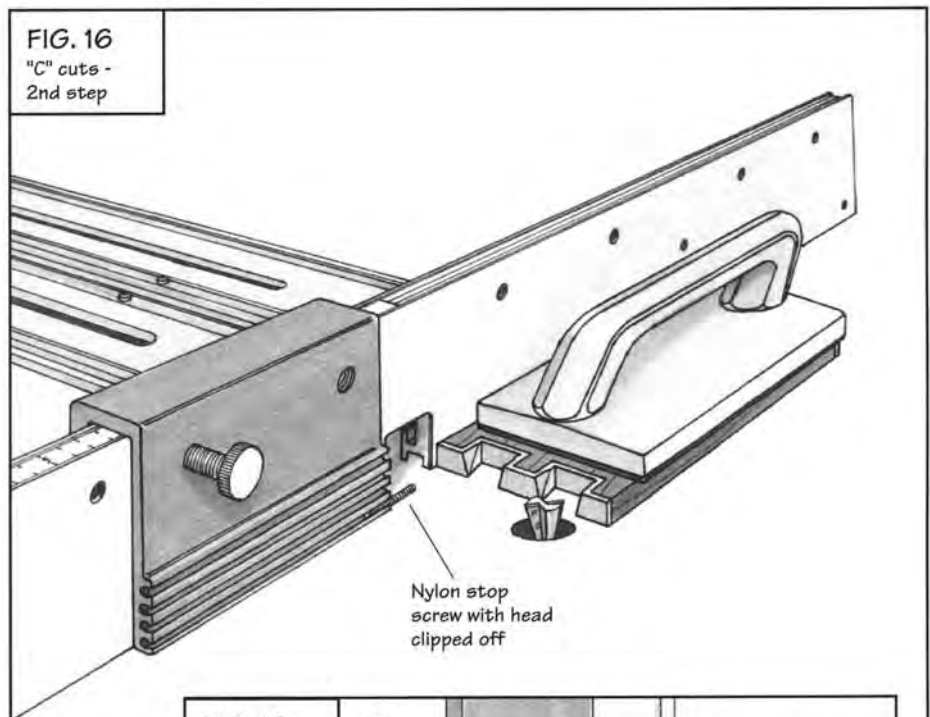

15 As you can see in Fig. 17, the cuts completed in Step 14 will leave a very small triangle of wood just outside the cutting arc of the dovetail bit. The final step to producing the Double-Double Through Dovetail is to remove this small piece of wood. This is easily accomplished by whittling off the triangle with a sharp pocket knife or chisel. Follow the cut created by the bit in Step 14 and cut straight back to the corner. The finished piece should look like the drawing in Fig. 17a.

16 You can now assemble your box. See pages 30-33 for techniques you can use to install a bottom in your box.

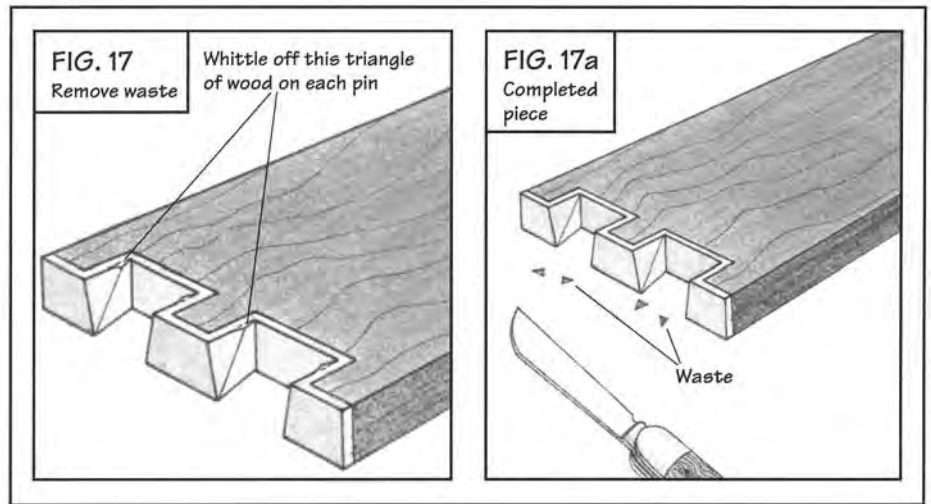

Formula for Success - INCRA Double-Double Through Dovetail

Here are some suggested stock widths and appropriate "center" cuts that you can use with the Double-Double Through Dovetail templates. These suggestions represent a positive entry point into this fascinating new joint and are by no means the only stock widths you can use.

Template - Double-Double Through Dovetail	
Stock Width	"Center" Cut
1-11/16"	8A
3"	3B
4-5/16"	8A
5-5/8"	3B

Interesting Variations

Box Joints and INCRA® Double Dovetails™

The templates for the Double-Double Through Dovetail were designed to serve triple duty. Used together following the technique previously described, they will produce the Double-Double Through Dovetail, but the templates can be used individually to produce other joints. Template ONE can be used to make a variably spaced box joint using a $\frac{3}{8}$ " straight bit. See Fig. 18. Template TWO can be used with a $\frac{1}{2}$ "-14° dovetail bit to produce an INCRA Double Dovetail, Fig. 19, or by following the technique described on pages 65-67, it can be used in making the Cornerpost Double Dovetail, Fig. 20. But that's not all! Pages 69-71 describe techniques for making another new joint using the Double-Double Through Dovetail templates - the INCRA Cornerpost Eagletail™.

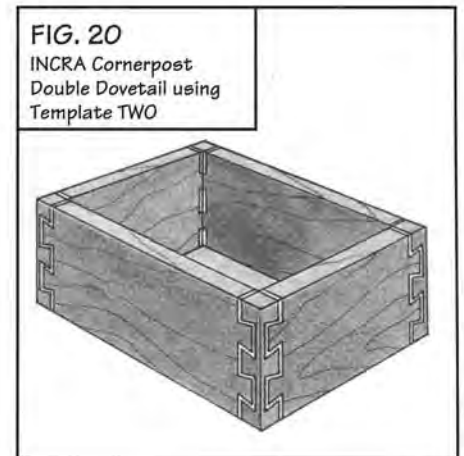
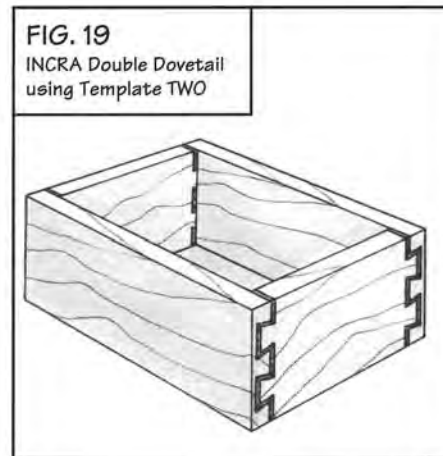
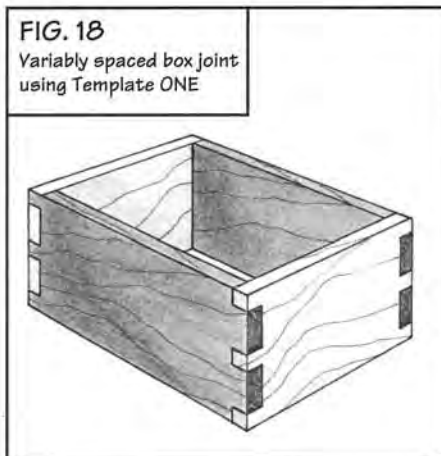

**INCRA®
DOUBLE-DOUBLE THROUGH DOVETAIL™**

INCRA DOUBLE-DOUBLE THROUGH DOVETAIL	5B	12A	11A	10A	4B	9A	8A	7A	3B	6A	ALIGN 5A	4A	2B	3A	2A	1A	1B	ONE
--------------------------------------------	----	-----	-----	-----	----	----	----	----	----	----	-------------	----	----	----	----	----	----	-----

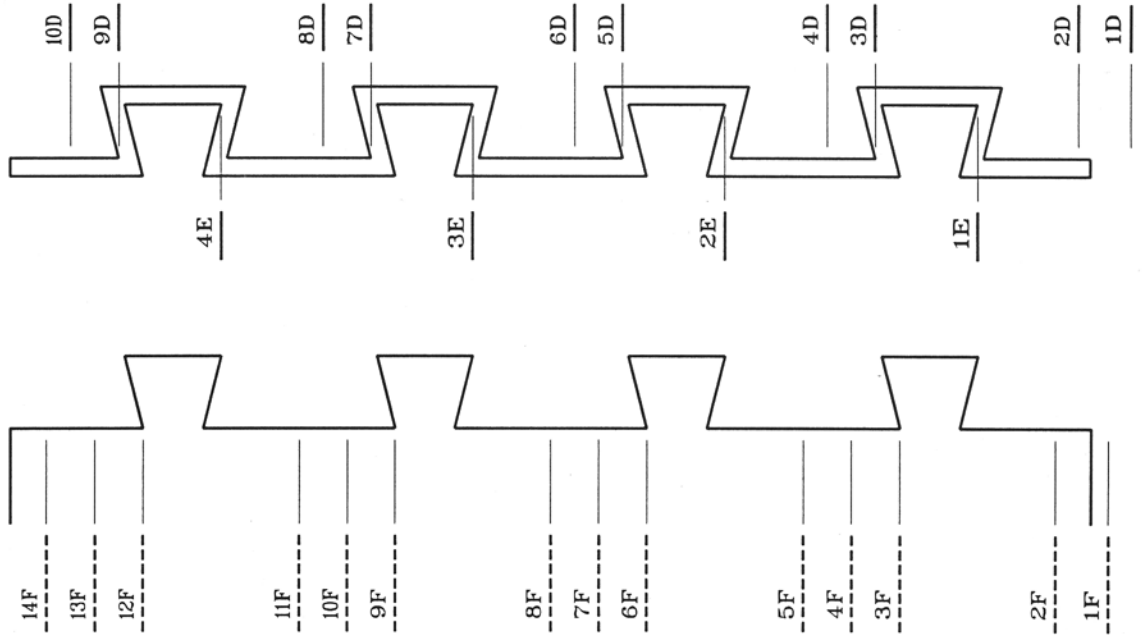
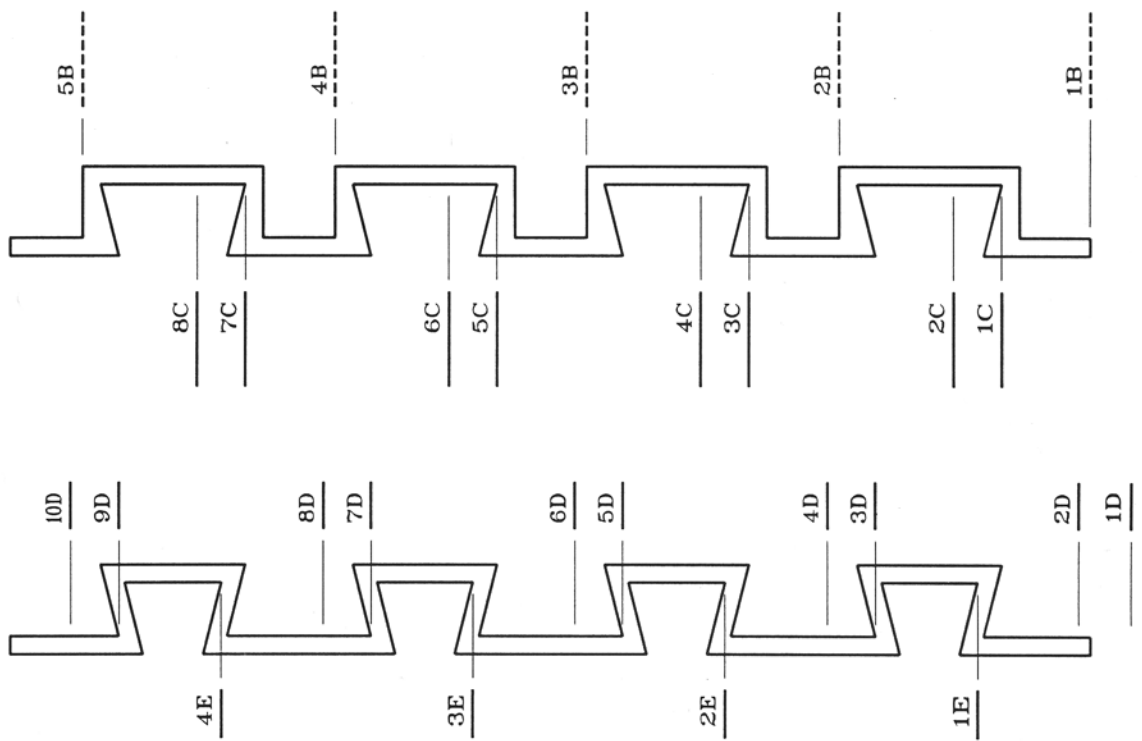
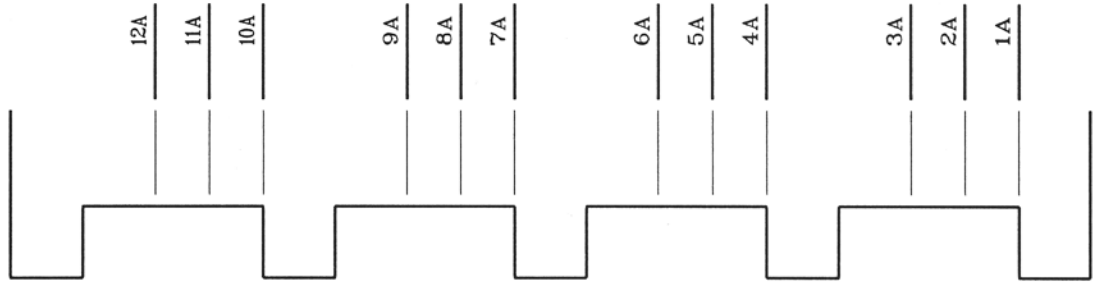

INCRA DOUBLE-DOUBLE THROUGH DOVETAIL	14F	10D	13F	9D	12F	8C	7C	4E	11F	8D	10F	7D	9F	3E	5C	6C	8F	6D	7F	5D	6F	ALIGN 4C	2E	3C	5F	4D	4F	3D	3F	2C	1E	1C	2F	2D	1F	1D	TWO
--------------------------------------------	-----	-----	-----	----	-----	----	----	----	-----	----	-----	----	----	----	----	----	----	----	----	----	----	-------------	----	----	----	----	----	----	----	----	----	----	----	----	----	----	-----

INCRA® Cornerpost Dovetail™

This decorative joint is very similar in construction to the INCRA Double Dovetail in that it requires a trim section that is cut and glued on in the same manner. The differences between this joint and the Double Dovetail appear in the final series of cuts used to join the side with the trim section to the remaining side.

I think the finished piece is quite dramatic. It is a very versatile joint that can be made with any of the standard dovetail templates using common stock thicknesses. Give it a try - you'll enjoy the results.

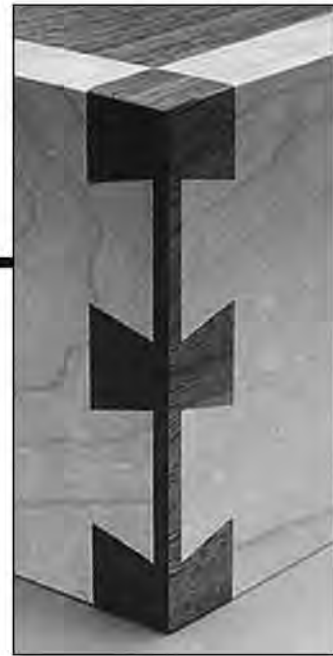

Initial Setup

1 Choose the dovetail template you wish to use and the corresponding dovetail bit. Install the dovetail bit in your router and set the depth of cut as described on pages 2-3 of the Master Reference Guide.

2 You will need six pieces of wood to make a box with this joint. Four pieces for the front/back and sides, one piece for the corner post section, and one piece for the "centering" process. Here are some rules regarding the width, thickness and length of the pieces:

WIDTH

All six pieces must be of equal width.

THICKNESS

Front/Back and Sides - These pieces must be at least $\frac{1}{16}$ " greater in thickness than the depth of cut set in Step 1 above. (For more information on selecting side stock thickness, see the chart on page 26.)

Cornerpost section - Must be equal in thickness to the front/back and sides.

"Centering" board - A piece of scrap stock $\frac{3}{4}$ " thick for all templates except DOV9 and DOVU. These two templates require a 1" thick board for centering.

LENGTH

Front/Back and Sides - The front/back pieces should be of equal length. The sides should both be of equal length.

Note: For more information on cutting the front/back and sides to length in order to produce a specific size box with Cornerpost Dovetail joinery see page 28.

Cornerpost section - 9" minimum when using templates DOV9, DOV10, DOVR, DOVS, DOVT, DOVU.* For all other templates the minimum length is 6".*

"Centering" board - 5" minimum*

* If the width of your stock exceeds this minimum, cut the length to match the width.

3 Choose a "center" cut on the template and, using the centering board, "center" your INCRA JIG using the method described on pages 22-24. In this joint the cornerposts are the pin sections. Remember the pin sections of any dovetails cut with INCRA JIG will always have a partial pin (solid wood)

on the inside and outside edges. Accordingly, the tail sections will always have open grooves on the inside and outside edges. See Fig. 1. When choosing a "center" cut, use the full-size diagram in your template book to ensure the appropriate cuts. Also, see the "Formula for Success" section on page 64 for some suggested stock widths, "center" cuts, and corresponding pin and tail designations for use with the DOV1 and DOVJ Templates.

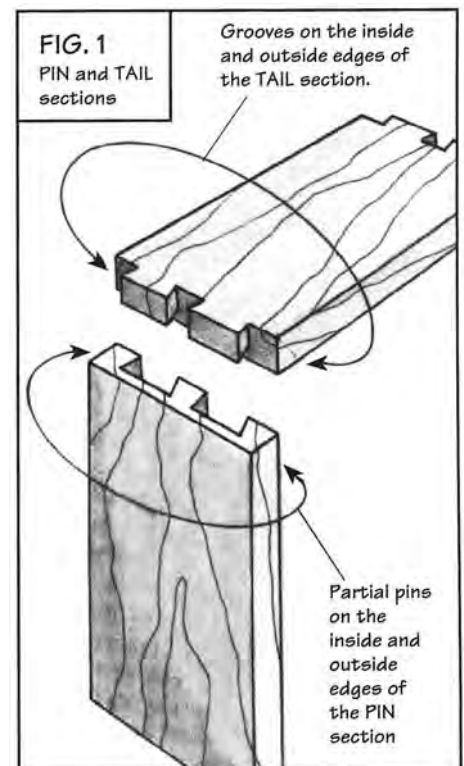

SEE ALSO

Centering	22
Stock Thickness, Router Bit and Template Selection	25
Boxes Made to Order	27

Cutting the Tail Sections

4 Cut a dovetail-shaped rabbet on both ends of either the sides or the front/back pieces. **ONLY TWO OF THE FOUR PIECES NEED THIS RABBET!** Cut a light scoring pass ($1/32$ ") and then two or three light subsequent passes, moving the fence back for each pass, until you have reached the rabbet width required for the template chosen. (Fig. 2.)

5 Place the front/back and the side pieces on the right angle fixture as shown in Fig. 3. Starting with a light scoring pass, make the tail series of cuts.

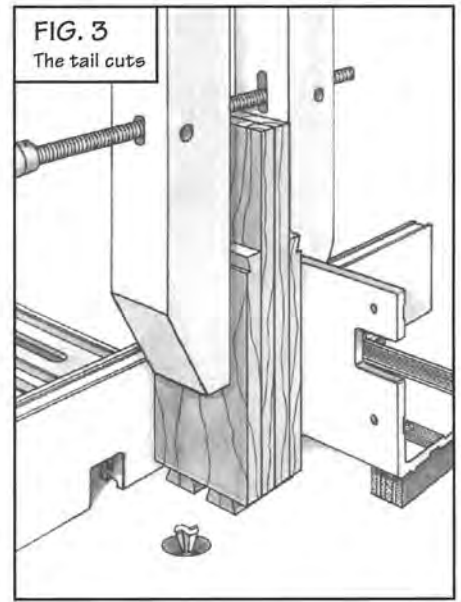

Cutting the Cornerpost Sections

6 Make the pin cuts along the length of the cornerpost section starting with the outside groove and moving in toward the fence. However, whenever a groove is wider than the bit, always cut the inside of each groove first, and then the outside, to avoid grabbing. Be sure to use a rubber soled push block. Fig. 4.

7 At the table saw using a sliding crosscut box or a miter gauge with an auxiliary fence, crosscut four pieces from the cornerpost section.

See Fig. 5. Each piece should be about $1/32$ " longer than the thickness of the side stock to allow for flush belt sanding in Step 9.

8 Glue the cornerpost pieces to both ends of the two non-rabbeted side or front/back pieces. Fig. 6. Allow to dry about one hour.

9 Belt sand the cornerpost sections flush with the faces of the two side or front/back pieces.

10 The two pieces with the cornerpost sections attached can now be cut as standard pin sections to mate with the two rabbeted pieces. Position an INCRA Stop on the outfeed side of the fence with the nylon screw as close as possible to the bit. Again make the pin cuts, this time with the stock face down on the table, Fig. 7. Be sure to use a rubber soled push block. Dry assemble the box and adjust the length of these last pin cuts as necessary by moving the INCRA Stop away from the bit. Recut if needed.

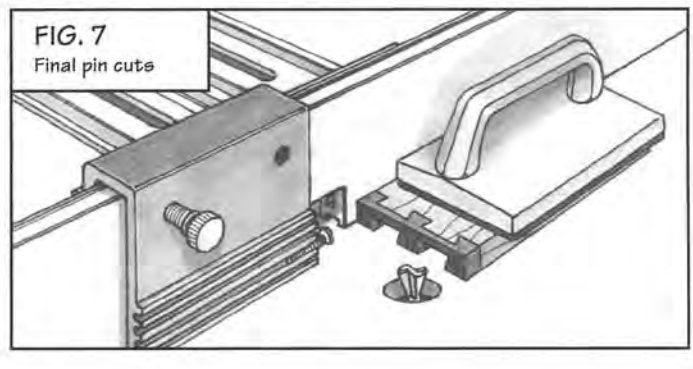
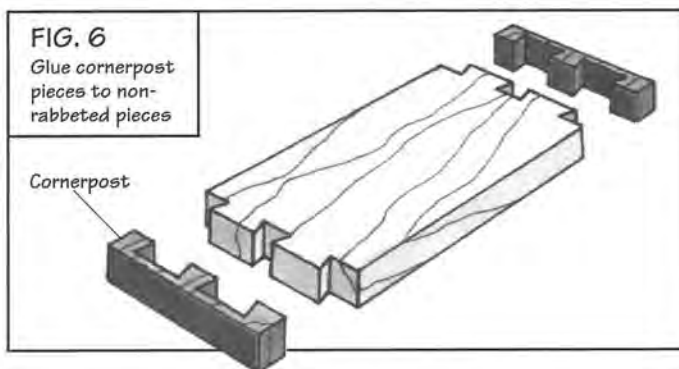
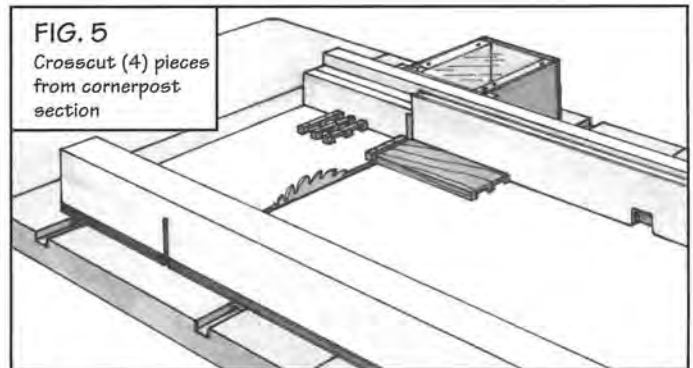
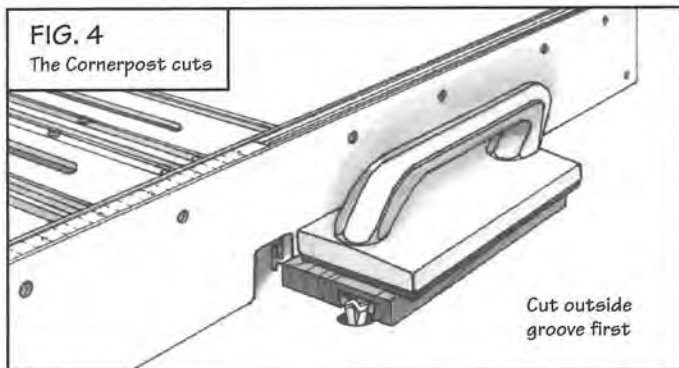

Formula for Success - INCRA Cornerpost Dovetail

Here are some suggested stock widths, "center" cuts, and the corresponding pin and tail cuts that you can use with the DOV1 or DOVJ templates. These two templates require the use of a $1/2"$ or $17/32"$ 14° dovetail bit. The suggestions are intended to present a positive starting point for use with the Cornerpost Dovetail technique and are by no means the only stock widths you can use, nor are these the only templates. Remember, **any** template that can be used to produce a half-blind dovetail can also be used to produce a cornerpost dovetail. There are literally hundreds of stock width and pattern combinations. Stock that is $1/2"$ thick will work well for either bit; however, you could also use $3/8"$ thick stock if you are using the $1/2"$ 14° bit.

TEMPLATE - DOV1

Stock Width	"Center" Cut	Tail Cuts	Pin Cuts
2-7/8"	5B	A	B
3-3/4"	5B	B	A
4-5/8"	5B	A	B
5-1/2"	5B	B	A
6-3/8"	5B	A	B
7-1/4"	5B	B	A

FIG. 8
Cornerpost Dovetail

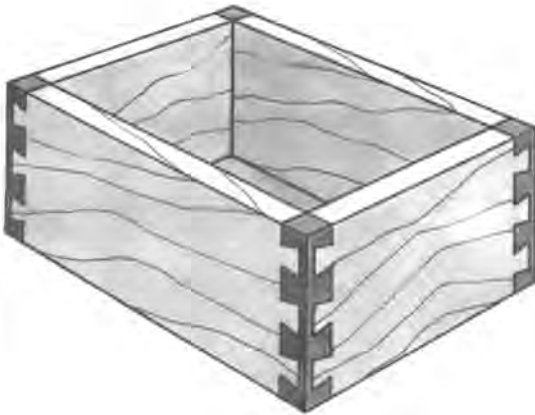

TEMPLATE - DOVJ

Stock Width	"Center" Cut	Tail Cuts	Pin Cuts
2-7/8"	10B	A	B
3-3/4"	10B	B	A
4-5/8"	10B	A	B
5-1/2"	10B	B	A
6-3/8"	10B	A	B
7-1/4"	10B	B	A
8-1/8"	10B	A	B
9"	10B	B	A

INCRA® Cornerpost Double Dovetail™

Here's an attractive variation of the Cornerpost Dovetail that can be made using any of the INCRA Double Dovetail templates. It transforms the beautiful Double Dovetail into a decorative joint visible from all four sides of the box.

The sides of this joint begin with the addition of a trim section just as in the Double Dovetail. The cornerpost is then added to two of the sides and the final cuts are made. Those of you who are already making the Double Dovetail will find this joint quite easy. If you would like to see a specific application of this corner joint, it is the featured joinery for the **Jewelry Box** project shown on pages 138-148.

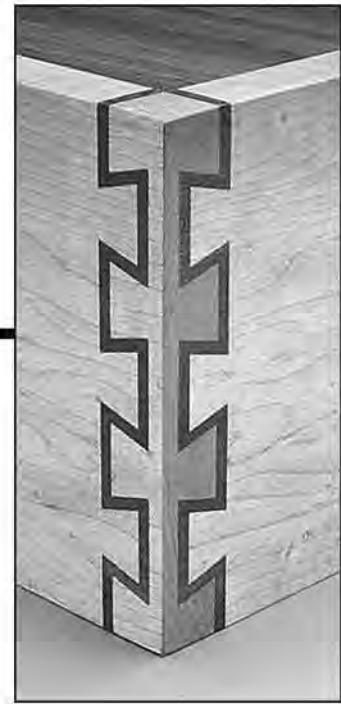

Initial Setup

1 Choose the Double Dovetail template you wish to use and the corresponding dovetail bit. Install the dovetail bit in your router and set the depth of cut as described on pages 2-3 of the Master Reference Guide.

2 You will need seven pieces of wood to make a box with this joint. Four pieces for the front/back and sides, one piece for the cornerpost section, one piece for the trim section, and one piece for the "centering" process. Here are a few rules regarding the width, thickness and length of the pieces:

WIDTH

All seven pieces must be of equal width

THICKNESS

Front/Back and Sides - These pieces

must be at least $\frac{1}{16}$ " **greater** in thickness than the depth of cut set in Step 1. (For more information on selecting side stock thickness, see the chart on page 26.)

Trim section - $\frac{3}{4}$ "

Cornerpost Section - Equal in thickness to the front/back and sides

"Centering" board - $\frac{3}{4}$ " (scrap stock)

LENGTH

Front/Back and Sides - The front/back pieces should be of equal length. The two side pieces should be of equal length.

Note: For more information on cutting the front/back and sides to produce a specific size box when using the Cornerpost Double Dovetail joint, see page 29.

Trim section - Using templates IDD1, IDD2, IDDA, IDDB, IDDC, IDDD, IDD3 - 9" minimum*

Using template IDDF ($\frac{5}{8}$ "-7° dovetail bit) - 11" minimum

Cornerpost section - Using templates IDD1, IDD2, IDDA, IDDB, IDDC, IDDD, IDDE - 6" minimum*

Using template IDDF ($\frac{5}{8}$ "-7° dovetail bit) - 8" minimum*

Centering board - 5" minimum*

*If the width of your stock exceeds this minimum, cut the length to match the width.

Design Tip

COLOR

Here are a few color contrast suggestions you can use when making this joint:

- 1** Front/Back & Sides - use a light colored wood (maple, birch, ash)
Cornerpost Section - same as above
Trim Section - use a dark colored wood (walnut, cherry or one of the many dark exotics)
See photo above.
- 2** Front/Back & Sides - use a dark colored wood (walnut, cherry or one of the many dark exotics)
Cornerpost Section - same as above
Trim Section - use a light colored wood (maple, birch, ash)
See Jewelry Box photo on page 138.
- 3** In each of the above examples, the cornerpost is from the same species as the front/back and sides. What about the introduction of a third species for the cornerpost? You could then use this third color wood in the lid frame to bring it all together.

SEE ALSO

Centering	22
Boxes Made to Order	27
Stock Thickness, Router Bit and Template Selection	25
Double Joinery Without a Surface Planer	53
Jewelry Box	138

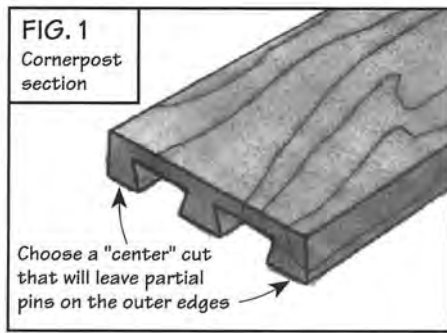

3 "Center" using one of the INCRA Double Dovetail templates. The cornerpost section will be the pin cuts (the "D" cuts on the template). Make sure that your center cut will leave the cornerpost section with partial pins (solid stock) on the outer edges when cut. See Fig. 1 and Fig. 8. Use the full-scale plans in your template book to help with "center" cut selection. Also see the "Formula for Success" on page 68 for some suggested "center" cuts and stock widths for use with the IDD1 and IDDD templates.

4 Place all four front/back and side pieces with a backing board on the right angle fixture and make the "A" cuts on both ends. (See Fig. 2.) Before removing the pieces from the right angle fixture, mark the sides of all pieces where they touch the fence.

5 Make the "B" cuts along the length of the trim section stock. (See Fig. 3.) Be sure to use a rubber soled push block for these cuts.

6 At the table saw, using a crosscut box or a miter gauge with an auxiliary fence, crosscut eight pieces from the trim section. Each piece should be slightly longer than the thickness of the front/back and side stock. See Fig. 4.

7 Glue the trim section pieces to both ends of the front/back and side pieces and allow to dry for about an hour. All four boards will have trim pieces on both ends.

8 Belt sand the trim sections flush with the faces of the front/back and side pieces.

9 Since the trim sections were cut from $\frac{3}{4}$ " stock, place a mark on the trim section $\frac{3}{32}$ " from the outermost glue joint. See Fig. 5. Using the crosscut box at the table saw, cut each of the ends off to the mark. (For more on this technique see "Double Joinery Without a Thickness Planer" on pages 53-54.)

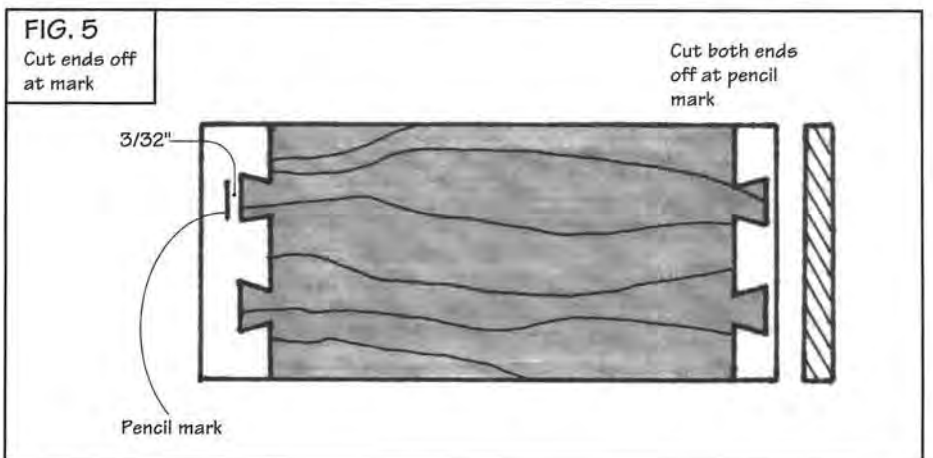
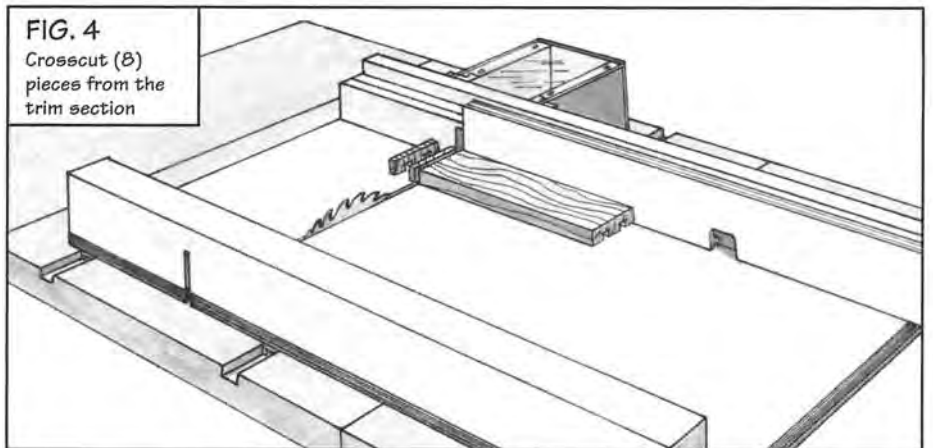
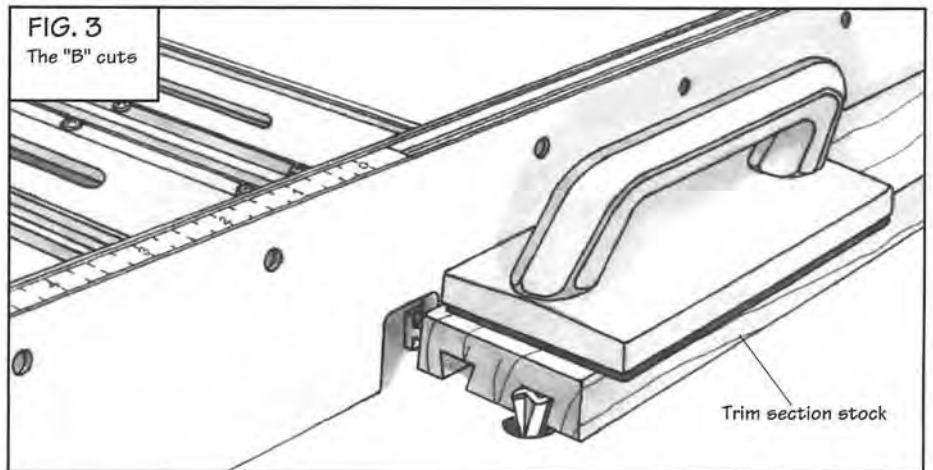
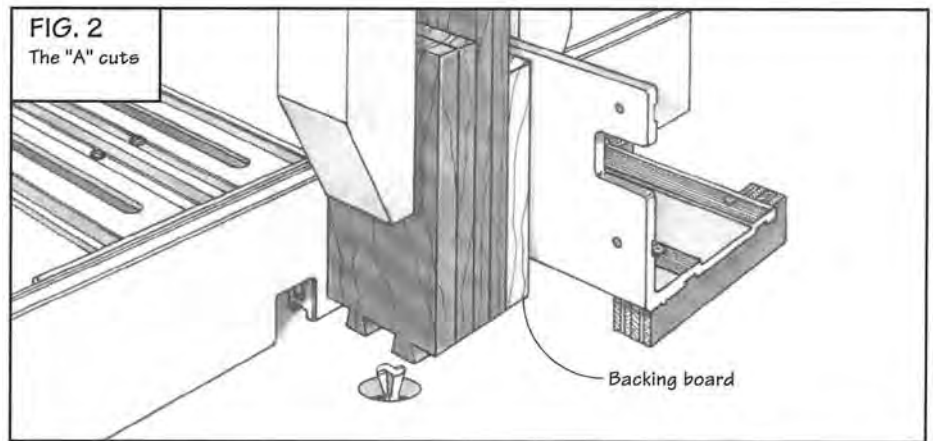

10 Cut a dovetail shaped rabbet on both ends of either the sides or the front/back pieces. **ONLY TWO OF THE FOUR PIECES NEED THIS RABBET!** Cut a light scoring pass ($\frac{1}{32}$ ") and then two or three light subsequent passes, moving the fence back for each pass until you have reached the rabbet width required for the template chosen. (Fig. 6.)

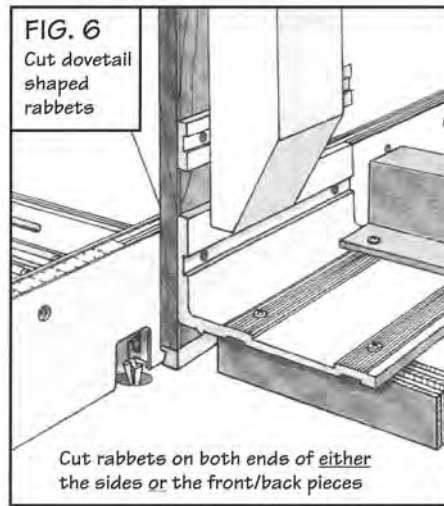

11 Place the front/back and the side pieces on the right angle fixture as shown in Fig. 7. Make sure the "fence edge" marked in Step 4 is placed adjacent to the fence. Starting with a light scoring pass, make the "C" cuts.

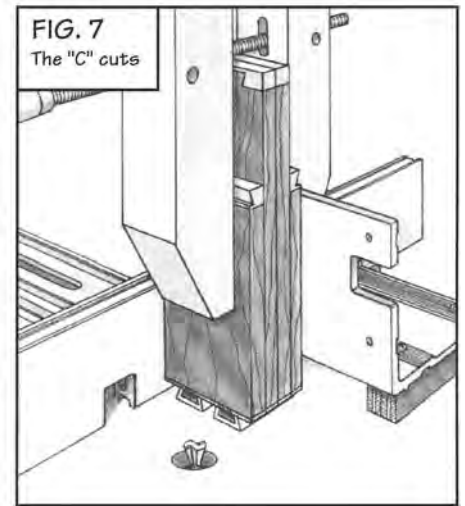

Adding the Cornerpost Section

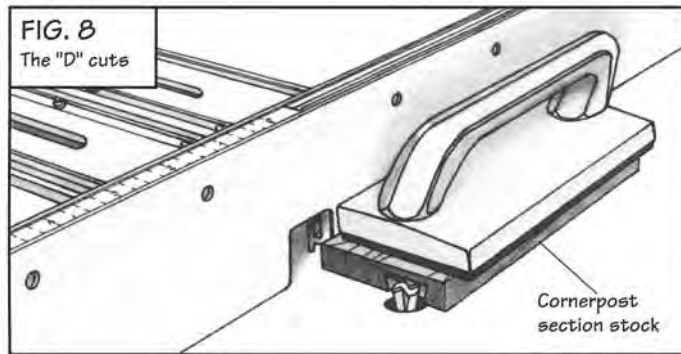

12 Make the "D" cuts along the length of the cornerpost section starting with the outside groove and moving in toward the fence. See Fig. 8. Again, make sure to use a rubber soled push block.

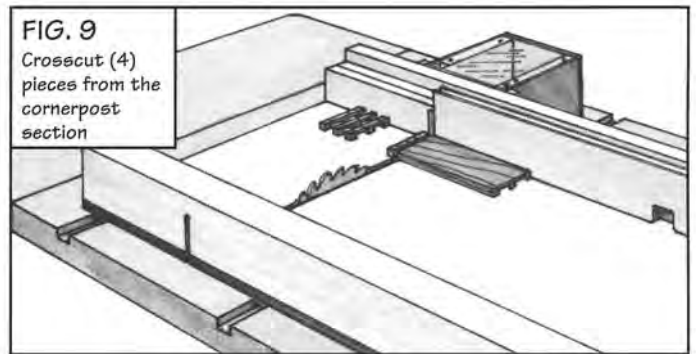

13 At the table saw, crosscut four pieces from the cornerpost section. Each piece should be just slightly longer than the thickness of the front/back and side pieces. (See Fig. 9.)

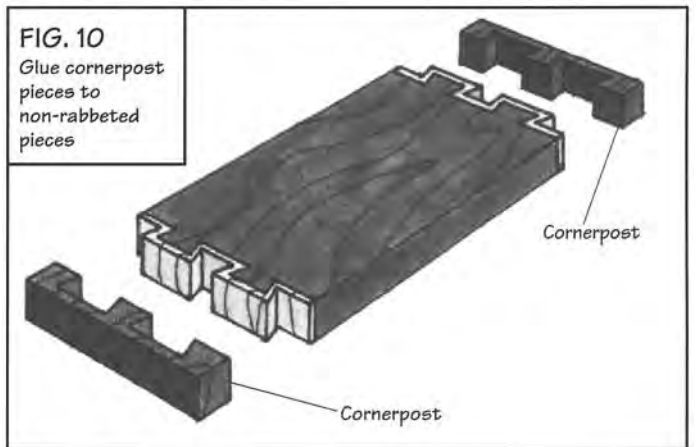

14 Glue the cornerpost pieces to both ends of the two non-rabbeted side or front/back pieces. See Fig. 10. Allow to dry for about one hour.

15 Belt sand the cornerpost sections flush with the faces of the two side or front/back pieces.

16 The two pieces with the cornerpost sections attached can now be cut as standard pin sections to mate with the two rabbeted pieces. Position an INCRA Stop on the outfeed side of the fence with the nylon screw as close as possible to the edge of the bit. This will produce a cut that is a little too short. Make the "D" cuts on both ends of the two pieces as shown in Fig. 11. Check the fit with the tail sections. Move the INCRA Stop away from the bit to lengthen the pin cuts as necessary for a flush fit.

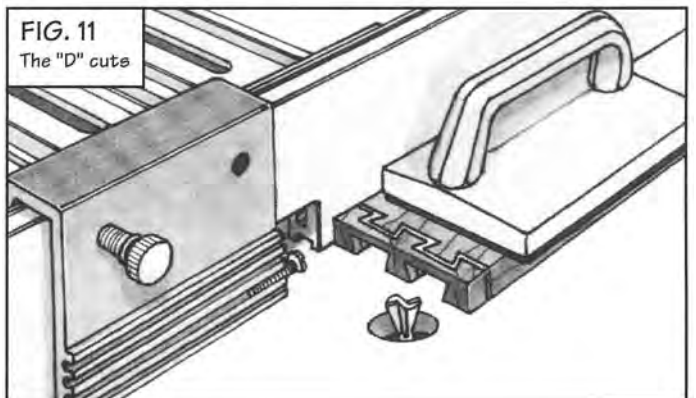

Formula for Success - Cornerpost Double Dovetail™

Here are some suggested stock widths and appropriate "center" cuts that you can use with the IDD1 or IDDD templates. You'll need a $\frac{1}{2}$ " or $\frac{17}{32}$ " 14° dovetail bit for use with these templates. The suggestions represent a positive entry point into this fascinating new joint and are by no means the only stock widths you can use, nor are these the only templates. As you learn more about your INCRA JIG and its capabilities, you'll find that there are hundreds of pattern and stock width combinations at your disposal. The templates mentioned will work on any stock thickness of $\frac{1}{2}$ " or greater, but I think it looks best on $\frac{1}{2}$ " stock.

TEMPLATE - IDD1

Stock Width	"Center" Cut
2-5/8"	4C
3-3/4"	3B
4-7/8"	4C
6"	3B

TEMPLATE - IDDD

Stock Width	"Center" Cut
2-5/8"	8C
3-3/4"	7B
4-7/8"	8C
6"	7B
7-1/8"	8C
8-1/4"	7B

FIG. 12
INCRA Cornerpost
Double Dovetail

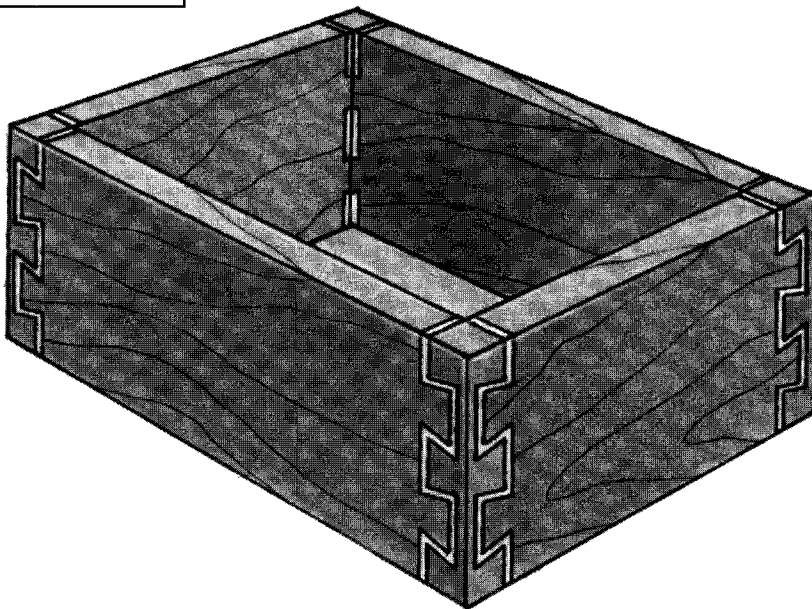

INCRA® Cornerpost Eagletail™

Fig. 1 shows a unique variation on the Cornerpost Dovetail (shown on pages 62-64) that uses cuts A, B, C and D on the Double-Double Through Dovetail templates. You'll need six pieces of wood to make a box featuring this joint. Four pieces for the front/back and sides, one piece for the cornerpost section, and one piece for the "centering" process. Here are some rules regarding the width, thickness and length of the pieces:

WIDTH

All six pieces must be of **equal** width. (See the chart on page 70 for a few suggested stock widths and corresponding "center" cuts for use in making this joint.)

THICKNESS

Front/Back and Sides - These pieces must be at least $\frac{1}{16}$ " **greater** in thickness than your dovetail bit's depth of cut. $\frac{1}{2}$ " to $\frac{5}{8}$ " stock should work fine.

Cornerpost section (box joint trim section) - must be **Equal** in thickness to the front/back and sides.

Centering board - $\frac{3}{4}$ "

LENGTH

Front/Back and Sides - The front/back pieces should be of equal length. The sides should be of equal length.

Note: For more information on cutting the front/back and sides to length in order to produce a specific size box when using the Cornerpost Eagletail joint, see page 28.

Cornerpost section (box joint trim section) - 6"

"Centering" board - 5"

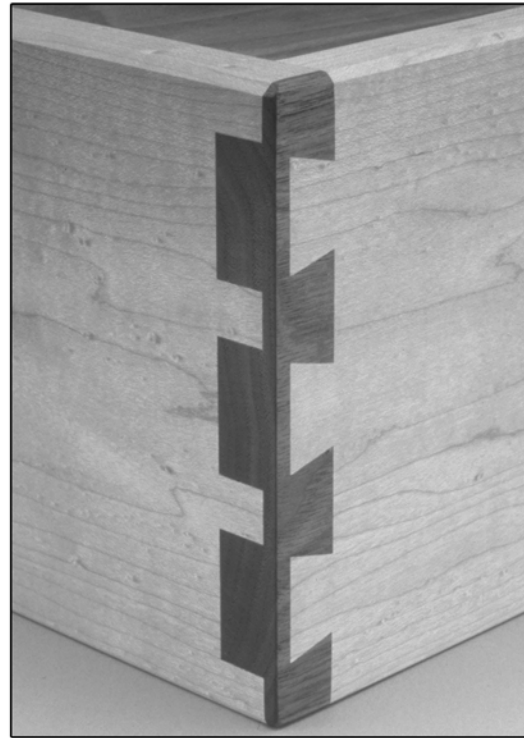
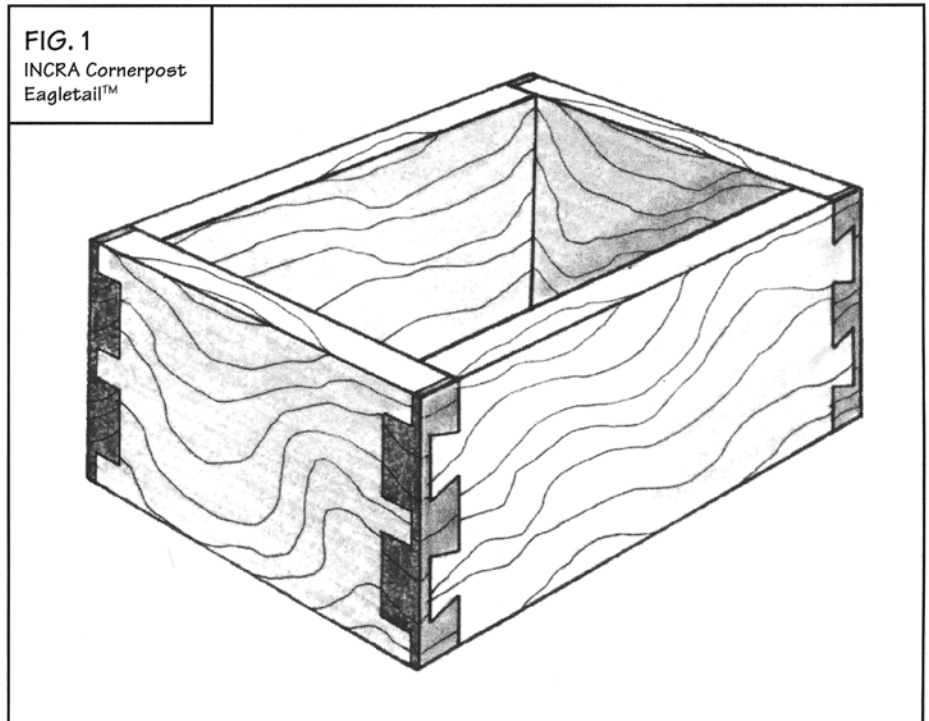

FIG. 1
INCRA Cornerpost
Eagletail™



SEE ALSO

Centering	
Boxes Made to Order	27
INCRA Double-Double Through Dovetail	55
INCRA Cornerpost Dovetail	62

Required Bits

$\frac{1}{2}$ " - 14° dovetail
 $\frac{3}{8}$ " straight bit



Cutting the Joint

- 1** Follow the instructions shown on page 56 for determining your dovetail bit depth of cut; then follow Steps 1 through 7 in the **INCRA Double-Double Through Dovetail** section on pages 57-58.
- 2** After the glue has set on the two box jointed sides, sand the cornerpost flush with the faces of the boards. It is not necessary to cut off the ends of the box jointed pieces.
- 3** Cut a dovetail-shaped rabbet on both ends of the remaining two uncut sides as shown in Fig. 2. Start with a light $1/32$ " scoring pass and then make three subsequent passes, each time moving the fence back $1/16$ " for a total rabbet width of $7/32$ ".
- 4** Clamp the two rabbeted boards to the right angle fixture as shown in Fig. 3 and, beginning with a light $1/32$ " scoring pass, make the "D" cuts.
- 5** The two pieces with the cornerpost sections attached can now be cut as standard pin sections to mate with the two rabbeted tail sections. Position an INCRA Stop on the outfeed side of the fence with the nylon screw as close as possible to the router bit. With the stock face down on the table as shown in Fig. 4, make the stopped "C" cuts. Be sure to use a rubber soled push block. Dry assemble the box and check the fit. If the tails don't fit flush with the ends of the pin sections, lengthen the pin cuts by moving the INCRA Stop away from the bit and re-cut as necessary.
- 6** You can now assemble your box. See pages 30-33 for techniques you can use to install a bottom in your Cornerpost Eagletail box.

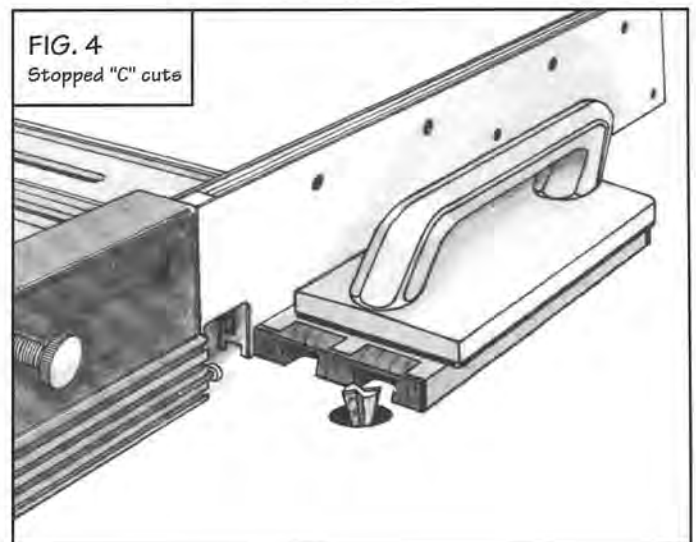
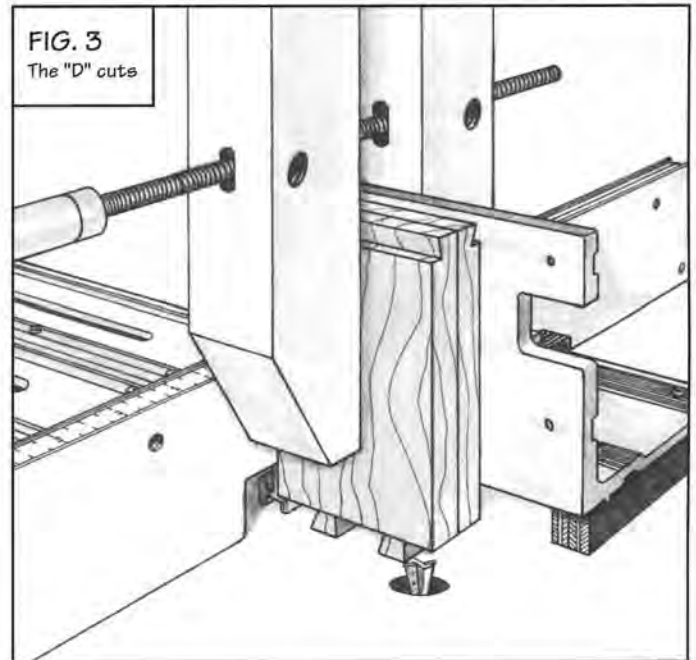
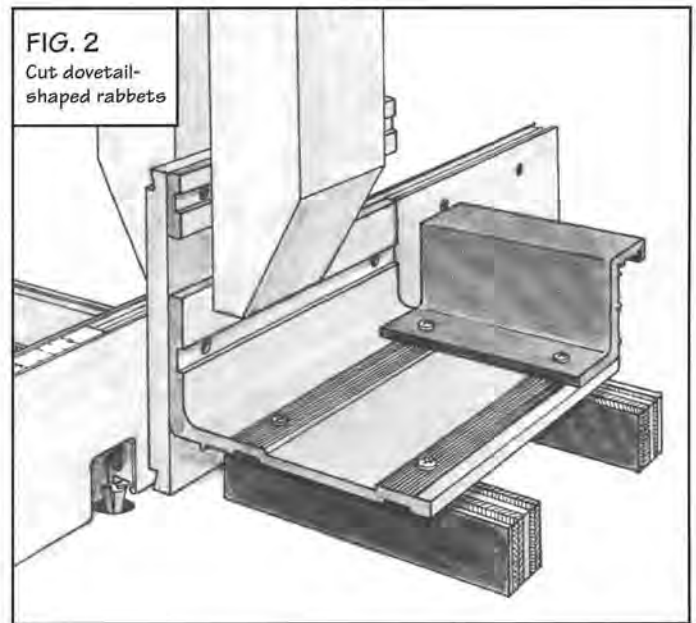

Formula for Success - INCRA Cornerpost Eagletail™

Here are some suggested stock widths and appropriate "center" cuts that you can use for the Cornerpost Eagletail joint. These suggestions represent a positive entry point into this fascinating new joint and are by no means the only stock widths you can use.

Template - Double-Double Through Dovetail	
Stock Width	"Center" Cut
1-11/16"	8A
3"	3B
4-5/16"	8A
5-5/8"	3B

INCRA[®] CORNERPOST EAGLETAIL™

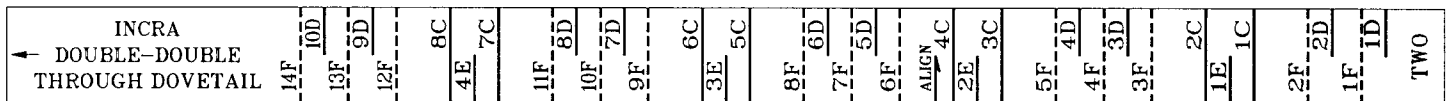
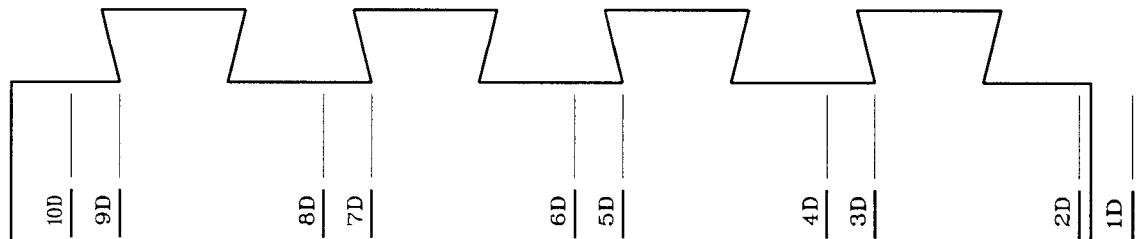
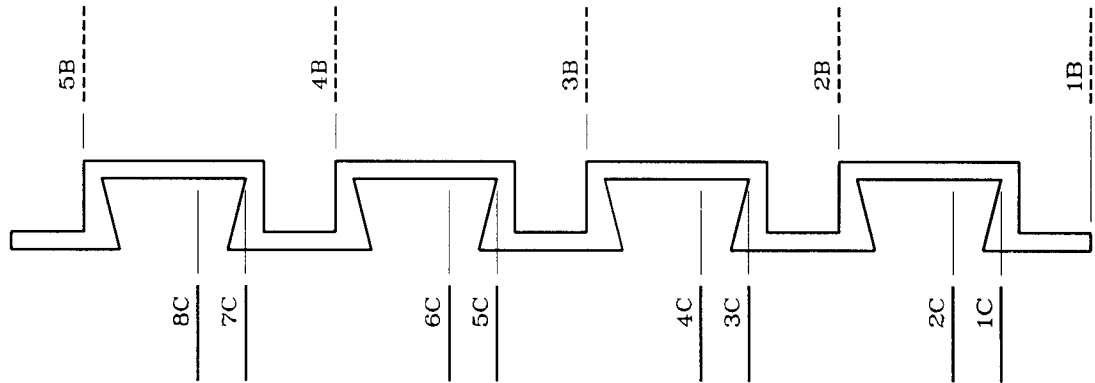
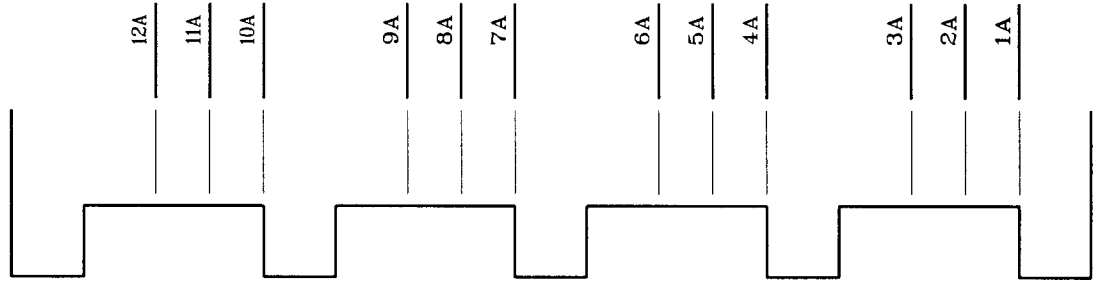
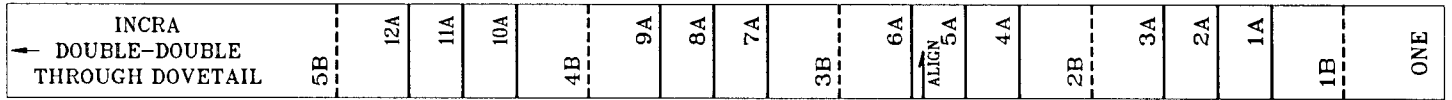

NOTE: THE INCRA CORNERPOST EAGLETAIL USES THE SAME TEMPLATES AS THE INCRA DOUBLE-DOUBLE THROUGH DOVETAIL.

IV

INCRA

JOINERY

In the few years since its first appearance in woodworking shops around the world, INCRA JIG has quickly established itself as one of the finest and most versatile joinery systems available. With it, box joints can be cut with any combination of pin and groove spacing imaginable. Half-blind and through dovetails can be quickly and accurately produced using the preprinted INCRA templates. By customizing the patterns as described on page 17 of the Master Reference Guide, you can create an unlimited number of joint patterns. Indeed, with joinery regarded by many as the measure of a woodworker's skill, it is not surprising that a tool offering such flexibility should do well. But box joints, half-blind and through dovetails were just the beginning.

Along with the traditional joinery, INCRA JIG also ushered in a new genre of woodworking joints, the decorative double joinery. The beautiful INCRA Double Dovetail and the spectacular INCRA Double-Double Box Joint were first, and as you'll see in the sections to follow, they'll not be the last. Two of the four new joints to follow, the Double-Double Through Dovetail and the Cornerpost Eagletail, are made using the templates included with this book. The other two decorative joints, the Cornerpost Dovetail and the Cornerpost Double Dovetail, can be made with any INCRA dovetail or double dovetail template using the techniques described. You'll also read about a new approach to making many of these double joints that doesn't require a thickness planer.

Included with each new joint discussion is a helpful chart and paragraph headed "Formula for Success". Here you'll find suggested templates, stock thickness, stock width, and the appropriate "center out" to use in the centering process. These suggestions, when used with the step-by-step descriptions for cutting the joints, will have you well on your way to creating your own INCRA masterpiece.

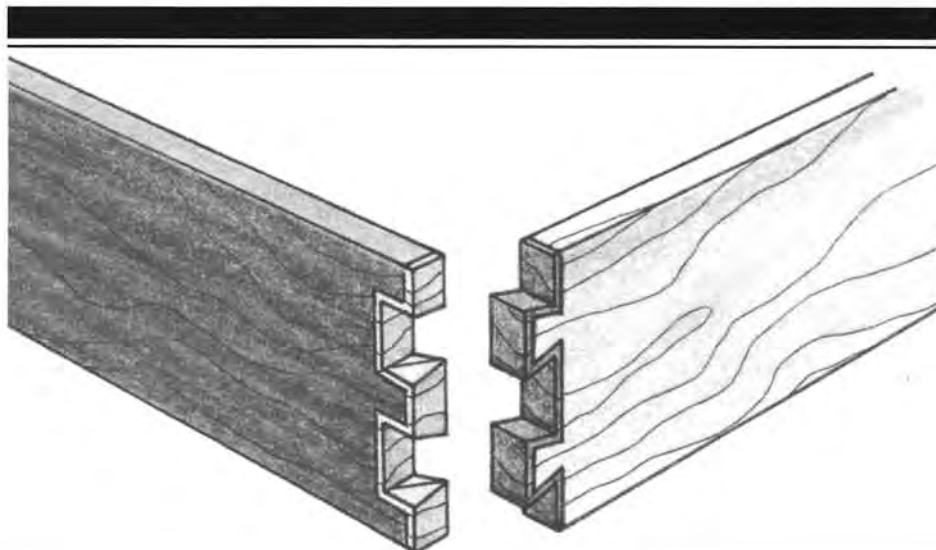

INCRA® Double Joinery Without a Thickness Planer

With the exception of the Double-Double Through Dovetail shown on pages 55-61, all of the INCRA double joints can be made without a thickness planer. In fact, having made several hundred of these double joints, it is the method of choice for me. Follow along as I describe the basic principle, then if you wish to try out the technique on a specific example, see the **Decorative Playing Card Box** on pages 119-122 and the **Trinket Box** on pages 132-136.

The method described in *The Original INCRA JIG Handbook and Templates* requires the trim section (referred to in the Handbook as the "center piece") to be planed to a thickness equal to $\frac{3}{32}$ " greater than the depth of cut. This is true for all of the INCRA double joinery with the exception of template IDDF from the INCRA Master Template Library, which has a trim section thickness equal to the depth of cut plus $\frac{1}{8}$ ". After gluing the trim sections to the mating tail or box joint section, you are left with a piece that resembles one of the drawings in Fig. 1. But what if you have no thickness planer? It was quite by accident that I discovered the answer.

I was working on a series of 13 jewelry boxes featuring the Double-Double Box Joint and was running short of time to complete them. In my haste, I cut the trim section pieces to length and



Nearly all of the INCRA double joints can be made without using a thickness planer, including the INCRA Double-Double Box Joint and the INCRA Double Dovetail shown here.

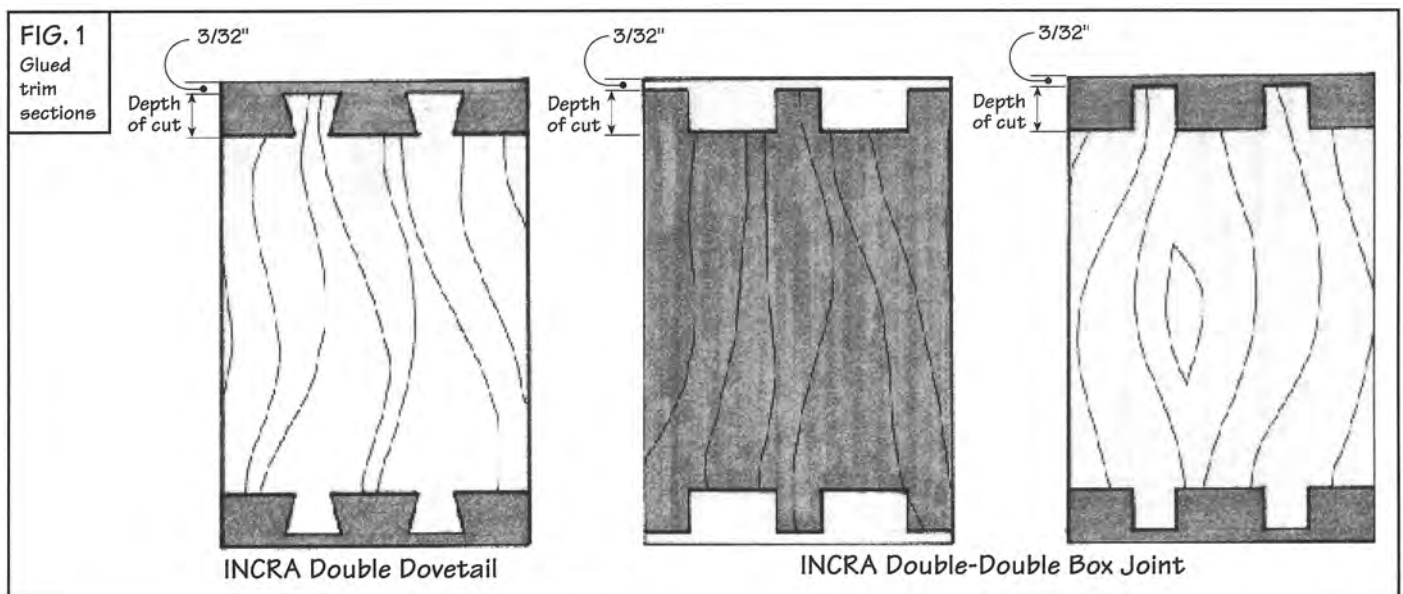

width and made the initial grooves along their length at the router table. It was not until I began gluing the trim sections to the mating box joint sections that I discovered my mistake. I had forgotten to thickness plane the trim section stock before cutting the grooves. All of my trim section pieces were $\frac{3}{4}$ " thick! I had no reserve stock, and the thought of the time and money wasted to remake the pieces was too much to bear. This is the solution I came up with:

1 Glue the $\frac{3}{4}$ " thick trim section pieces to the box sides as shown in Fig. 2. Allow the glue to set for about one hour then belt sand the trim sections flush with the faces of the box sides. With a sharp pencil place a mark on the trim section $\frac{3}{32}$ " from the outermost glue joint, see detail Fig. 2.

2 Now at the table saw using a sliding crosscut box as shown in Fig. 3, or a miter gauge with an auxiliary fence as shown in Fig. 4, cut the ends of each piece to the mark. Sneak up on each cut so that you don't cut inside the mark. When you are finished cutting both ends of each piece they should look like the examples shown in Fig. 1.

3 Using the technique above, you can simply buy $\frac{1}{2}$ " or $\frac{3}{8}$ " thick stock for the box sides (I use $\frac{1}{2}$ " stock for most boxes featuring the INCRA Double Dovetail, and $\frac{3}{8}$ " stock for the INCRA Double-Double Box Joint). For the trim sections, any contrasting stock about $\frac{3}{4}$ " thick will do.

FIG. 2
Mark trim section

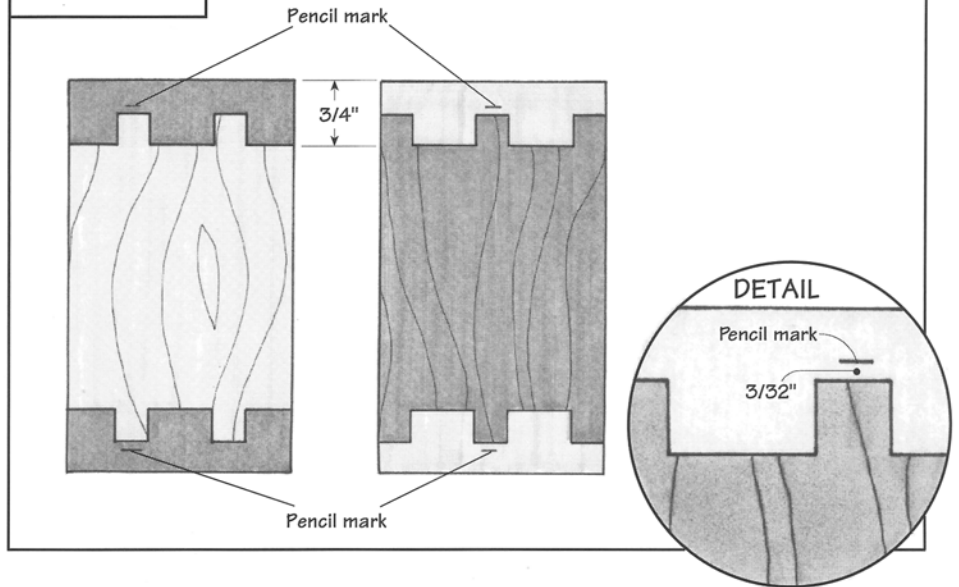

FIG. 3
Cut off ends -
Crosscut box

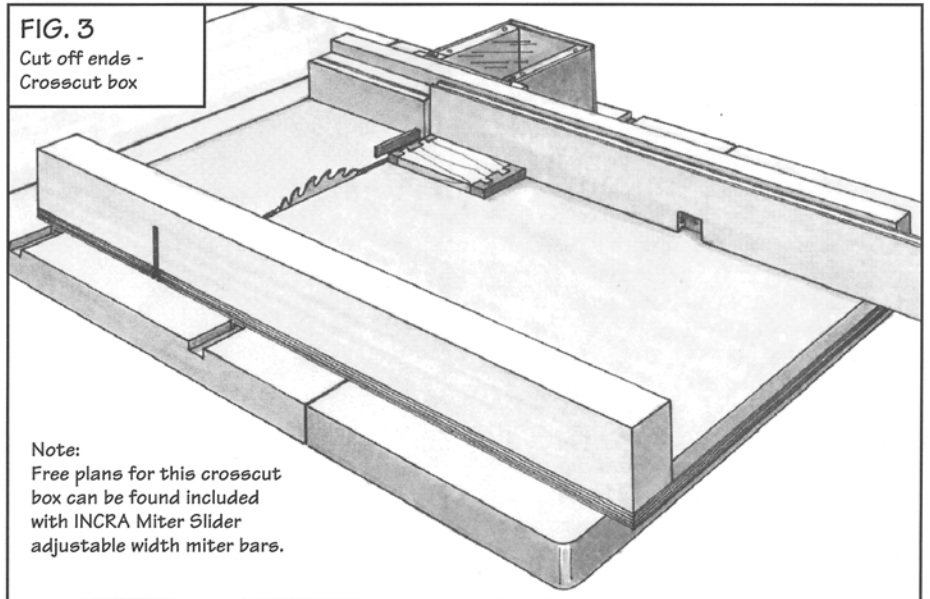
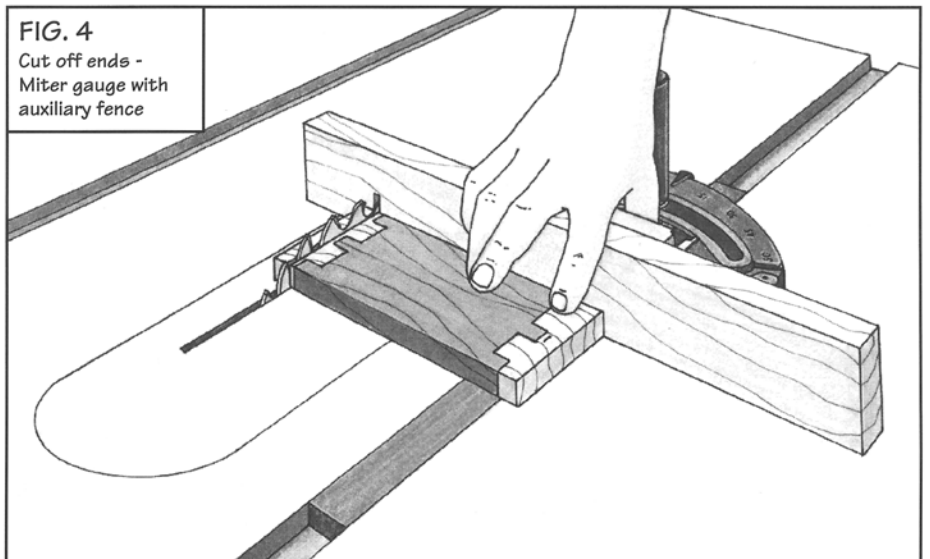

FIG. 4
Cut off ends -
Miter gauge with
auxiliary fence



INCRA® Double-Double Through Dovetail™



The Double-Double Through Dovetail is the first in the collection of INCRA double joinery to require the use of two router bits - a dovetail and a straight bit. In this respect, it may be deemed the most complex of the decorative joints. Once you have mastered it, you should consider yourself a certified INCRA "PRO"! In many respects, this joint is similar to the Double-Double Box Joint. If you have not yet made the Double-Double Box Joint, it would be a good idea to review the discussion of this joint in the Master Reference Guide. Also review the section of the video covering through dovetails. Throughout this section, you will be using the Double-Double Through Dovetail templates labeled **ONE** and **TWO** that are supplied with this book. You should also refer to the full-sized plans for this joint on page 61 at the end of this section.

Let's begin by analyzing the exploded view of the Double-Double Through Dovetail in Fig. 1 and Fig. 2. As you can see, the joinery begins with the addition of a trim section to the ends of the two pieces in the joint. The piece on the left half of each drawing is joined to a trim section with variably spaced box joints cut with a straight bit. The piece on the right half of each drawing is joined to a trim section with a variably spaced dovetail joint cut with the dovetail bit.

In the final series of cuts shown in Fig. 2, a dovetail bit is used to join together the two sides. The "D" cuts are very straightforward, as shown in Fig. 14 on page 59. The "C" cuts are made as shown in Fig. 16. This is also shown in The Complete INCRA JIG Video in the section describing pin cuts for through dovetails.

Now that you've seen the essence of this fascinating new joint, let's look at it step-by-step.

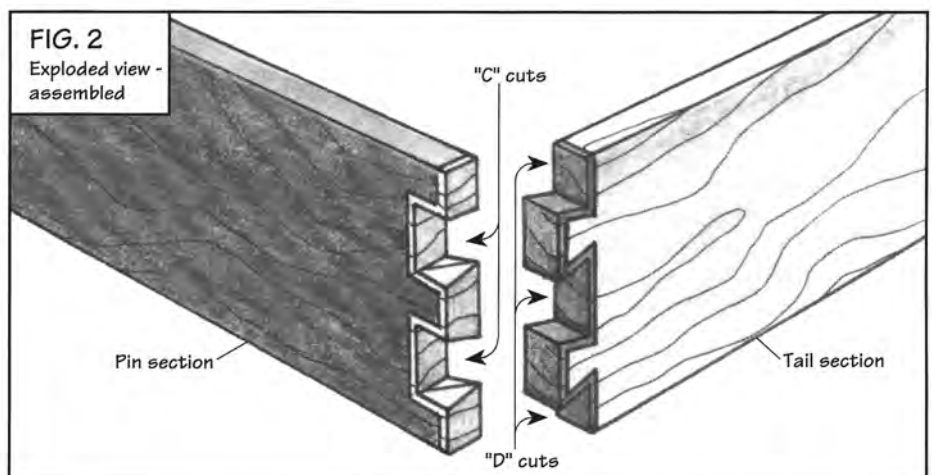
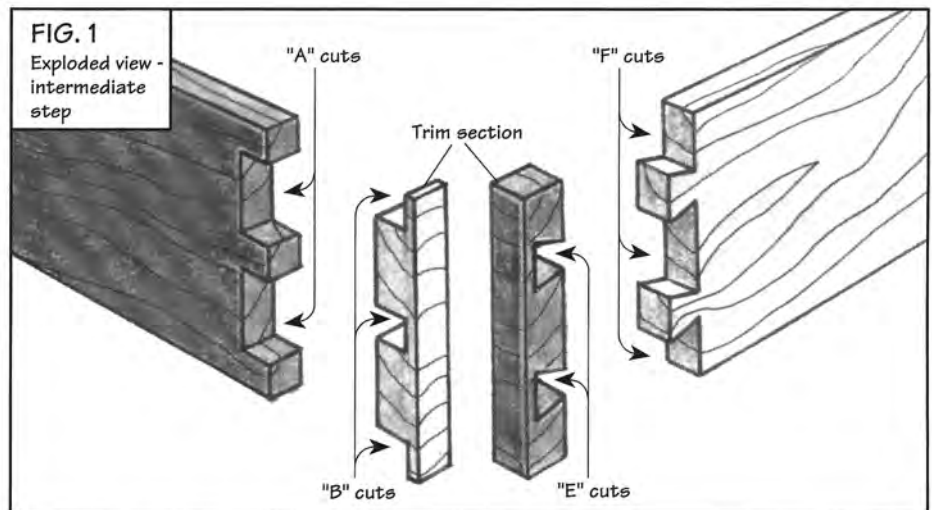

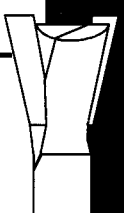
Required Bits	
1/2" - 14° dovetail	
3/8" straight bit	

SEE ALSO	
Centering	22
Boxes Made to Order	27

Design Tip

Color Arrangement:

In Fig. 2 on page 55, the light dovetail side of the piece has a dark trim section while the dark box jointed side has a light trim section. This is a pleasing arrangement, but don't limit yourself. With four pieces of wood in the corner joint, each could be a different color.

Or, you might try making all four sides blond and the two trim sections each a different color.

Use your imagination!

Stock Dimensions

You will need seven pieces of wood to make a box with this corner joint. Four pieces for the front/back and sides, one piece for the box joint trim section, one piece for the dovetail trim section, and one piece for the "centering" process. Here are a few rules regarding the width, thickness, and length of the pieces:

WIDTH

All seven pieces must be of equal width (see the "Formula for Success" chart on page 60 for a few suggested stock widths and corresponding "center" cuts to use when making this joint)

THICKNESS

Front/Back and Sides - These pieces must be equal in thickness to the depth of cut for your dovetail bit.

Box joint trim section - $3/4"$

Dovetail trim section - $3/4"$

"Centering" board - $3/4"$

LENGTH

Front/Back and Sides - The front/back pieces should be of equal length. The side pieces should be of equal length.

Note: For more information on cutting the front/back and side pieces to length to produce a specific size box when using the Double-Double Through Dovetail joint, see page 29.

Box joint trim section - 6"

Dovetail trim section - 6"

"Centering" board - 5"

Determine Dovetail Bit Depth of Cut

When you begin actually cutting the wood for this joint, you will start with the straight bit cuts ("A" and "B" cuts), however, the depth of cut for the straight bit must match the depth of cut used with the dovetail bit in cutting the "C" through "F" cuts. Since every dovetail bit produces a slightly different depth of cut for a given spacing, it is very important that you determine the depth of cut for your dovetail bit before installing the straight bit for the "A" and "B" cuts. It is also important to know your dovetail bit depth of cut first because the stock thickness for the Double-Double Through Dovetail must be equal to the depth of cut.

To set the depth of cut, install a $1/2"$ - 14° dovetail bit in your router table and set the bit depth using the method described on pages 2-3 of the Master Reference Guide. (Also shown here in Figs. 3 and 4.) For this method you will make two side by side dovetail cuts across the end grain of two boards clamped to your right angle fixture. (Fig. 3) The two cuts must be $13/16"$ apart and the bit must be partially recessed in the notch in your fence for the first cut.

Cut locations 2F and 3F on Template TWO are $13/16"$ apart if you would like to use it to help in setting the depth of cut. Remember: After making the two cuts, test the fit as shown in Fig. 4 and use the rule "Heighten to tighten, lower to loosen" to adjust the bit height. After adjusting, repeat the two cuts on the uncut ends of the two boards and again check the fit. Adjust and recut as necessary until you achieve a close fit between the two pieces. Mark the cuts with the good fit. These marked cuts on the scrap boards can now be used as a height gauge for setting your straight bit depth of cut and later for resetting the dovetail bit depth of cut. The scrap can also be used as a thickness gauge when you plane down the stock for the sides of your box.

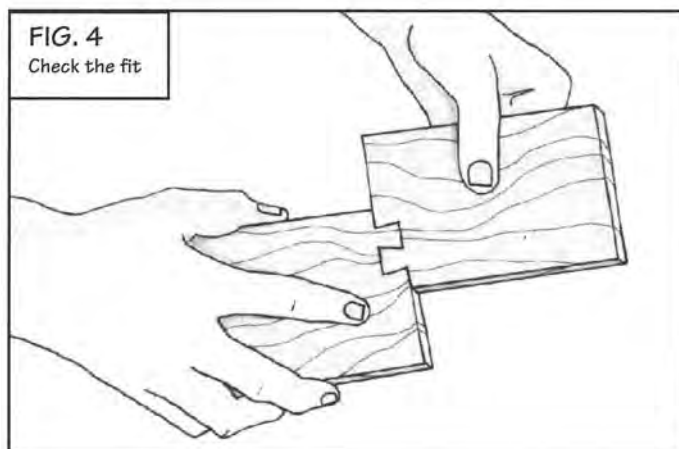
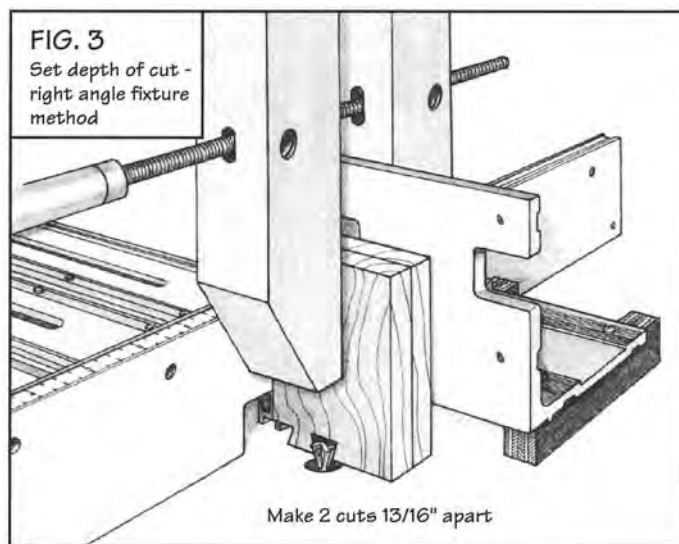

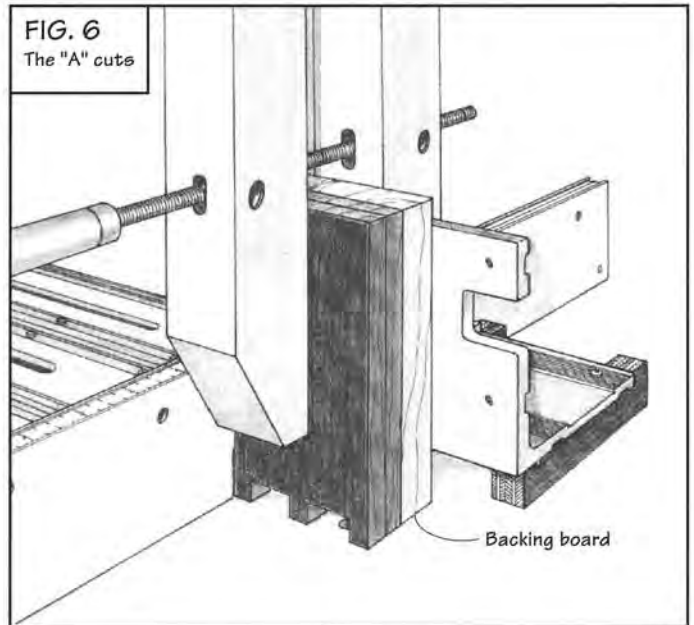
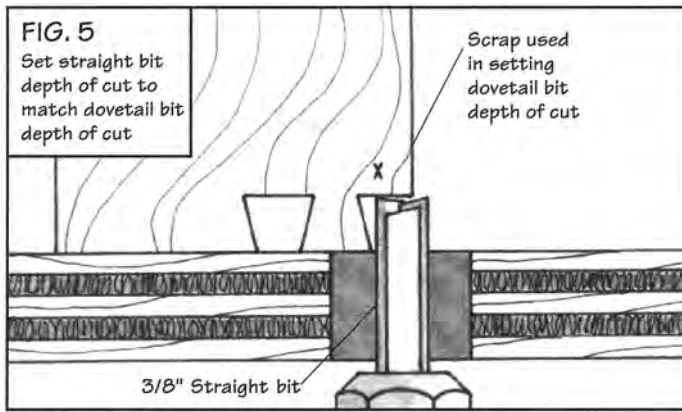

Cutting the Joint

1 Remove the dovetail bit and install a $\frac{3}{8}$ " straight bit in your router table. Set the straight bit depth of cut to match the depth of cut of the dovetail bit. Use the marked cut on one of the scrap pieces retained in setting the dovetail bit depth of cut as a gauge to help. Fig. 5.

2 Install Template ONE in your INCRA JIG with the arrow on the template pointing away from the fence. Depending on your stock width, lock your INCRA JIG to cut 8A or 3B and "center" using the centering board. (See the "Formula for Success" chart on page 60 for several suggested stock widths and the corresponding "center" cut.)

3 Clamp either the sides or the front/back pieces to the right angle fixture with a backing board as shown in Fig. 6 and make the "A" cuts. Before removing the pieces from the right angle fixture, mark the "fence" edge of the two pieces with a pencil. Now repeat the "A" cuts on the opposite ends of the boards, being sure to place the "fence" edge adjacent to the fence before clamping to the right angle fixture.

4 Make the mating "B" cuts along the length of the box joint trim section as shown in Fig. 7. Be sure to use a rubber soled push block for this operation. When making the cuts on the inside edge of the stock always start with a light $\frac{1}{32}$ " scoring pass and move to the final groove width in several side by side passes. On the outside edge of the board, start with a $\frac{1}{32}$ " pull-cut as described in "Rabbeting the Outside Edge" on page 9. Then work your way back to the "B" cut on the template in several light $\frac{1}{16}$ " pull-cut passes.

5 At the table saw, using a crosscut box or a miter gauge with an auxiliary fence, crosscut four pieces from the box joint trim section. See Fig. 8. Each piece should be about $\frac{1}{32}$ " longer than the thickness of the sides cut in Step 3 to allow for belt sanding flush in Step 11. Glue the trim pieces to the ends of the sides cut in Step 3 and set aside, Fig. 13.

6 Release the cam clamp and slide your INCRA JIG carriage to position the hairline cursor directly over the "Align" mark on Template ONE. Lock the cam clamp in place, then remove Template ONE. Slide Template TWO into the scale slot with the arrow on the template pointing away from the fence and position the template with the "Align" mark directly under the hairline cursor. This positions Template TWO so that the remaining cuts will be aligned with those on Template ONE.

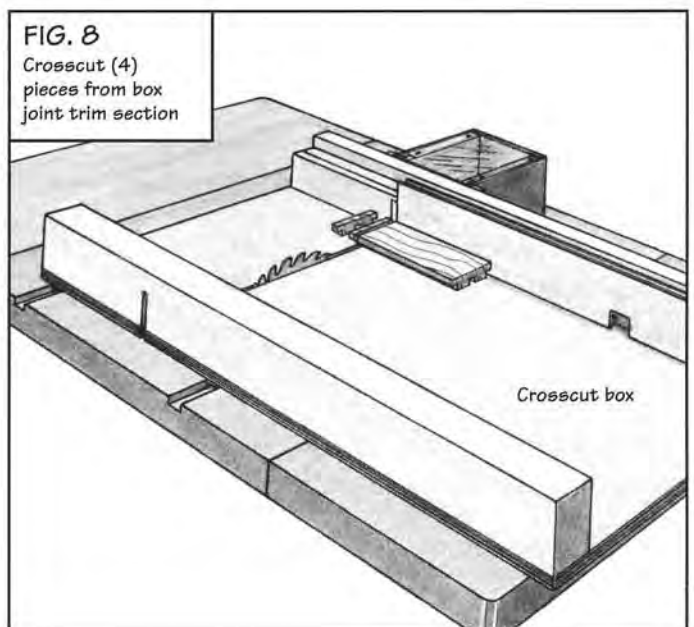
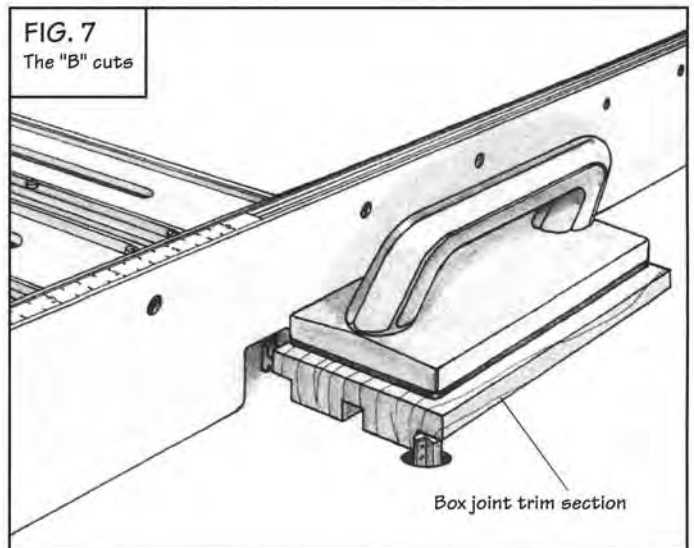

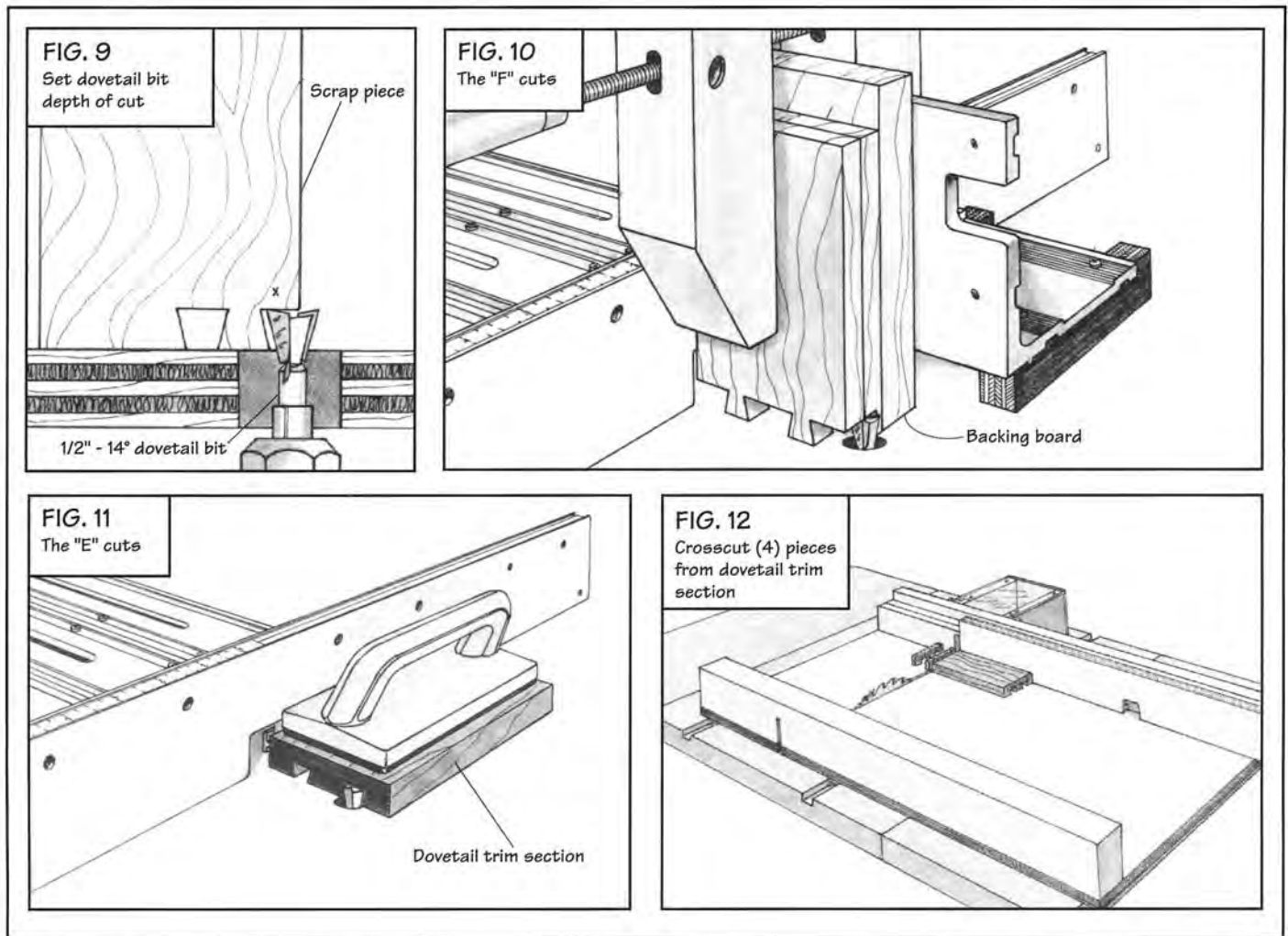

7 Remove the straight bit and re-install the 1/2" - 14° dovetail bit in the router table. Set the bit height again using the marked cut on one of the scrap pieces retained in setting the depth of cut earlier, Fig. 9.

8 Clamp the remaining two sides to the right angle fixture with a backing board as shown in Fig. 10 and make the "F" cuts. Before removing the boards from the right angle fixture, mark the "fence edge" of the pieces with a pencil. Now repeat the "F" cuts on the opposite ends of the boards making sure to place the "fence edge" adjacent to the fence before clamping to the right angle fixture.

9 Cut the mating "E" cuts along the entire length of the dovetail trim section as shown in Fig. 11. Be sure to use a rubber soled push block for this operation.

10 At the table saw, using a crosscut box or a miter gauge with an auxiliary fence, crosscut four pieces from the dovetail trim section. See Fig. 12. Each piece should be about 1/32" longer than the thickness of the sides or front/back pieces cut in Step 8. Glue the trim pieces to the ends of the sides cut in Step 8 and set aside, Fig. 13.

11 After the glue has set (allow about 1 hour), belt sand the trim pieces flush with the faces of the front/back and side pieces (all four). At the table saw cut off the ends of each piece to 3/32" from the outermost glue joint. See Fig. 13.

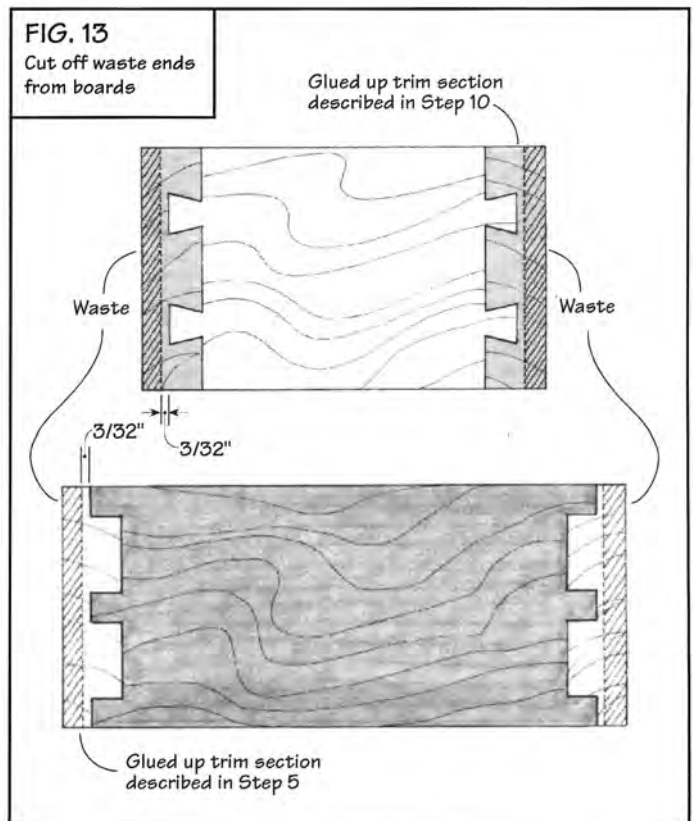

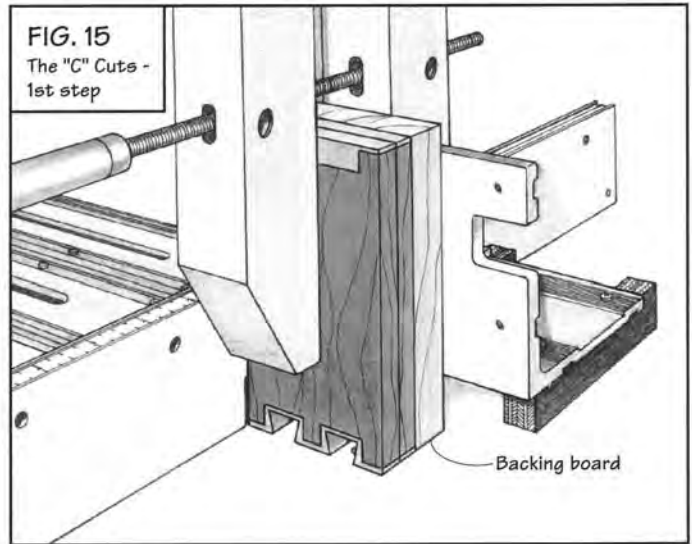
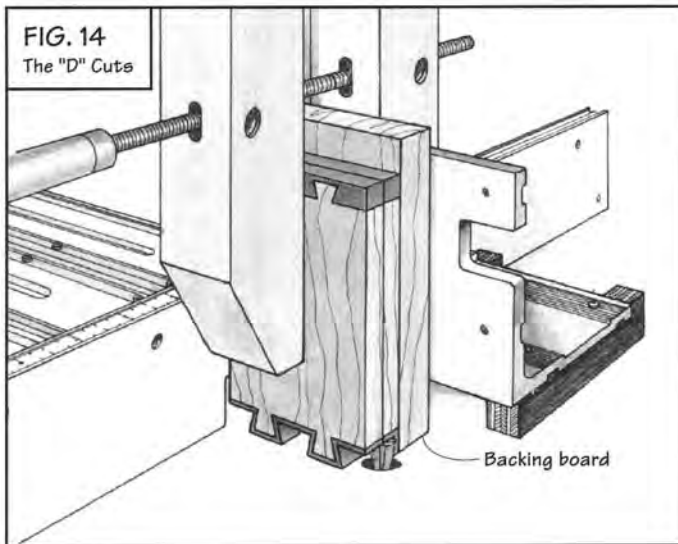

Now that you have added the trim pieces to all four front/back and side pieces, the "C" and "D" cuts will be used to cut a through dovetail.

The "D" cuts will be made on the tail pieces (the two dovetailed boards) and the "C" cuts will be used for the pins (the box jointed boards).

12 Place the dovetailed boards glued up in Step 10 on the right angle fixture with a backing board as shown in Fig. 14 and make the "D" cuts on both ends of the pieces. Be sure to place the "fence edge" of the boards adjacent to the fence before clamping to the right angle fixture.

13 Place the box jointed boards glued up in Step 5 on the right angle fixture with a backing board as shown in Fig. 15 and make the "C" cuts on both ends of the pieces. Be sure to place the "fence edge" of the boards adjacent to the fence before clamping to the right angle fixture.

14 Remove the box-jointed boards from the right angle fixture and, with the boards face down on the table, re-cut the "C" cuts as shown in Fig. 16. You'll need to set up an outfeed INCRA Stop to stop the cut before the arc of the dovetail bit touches the flat surface left by the cuts in Step 13. See Fig. 16a. The nylon stop screw on the INCRA stop will need to be in the lowest position and you'll need to cut the head of the screw off. At each "C" location on the template make the cuts on both ends of each board keeping the same face down on the table for all of the cuts.

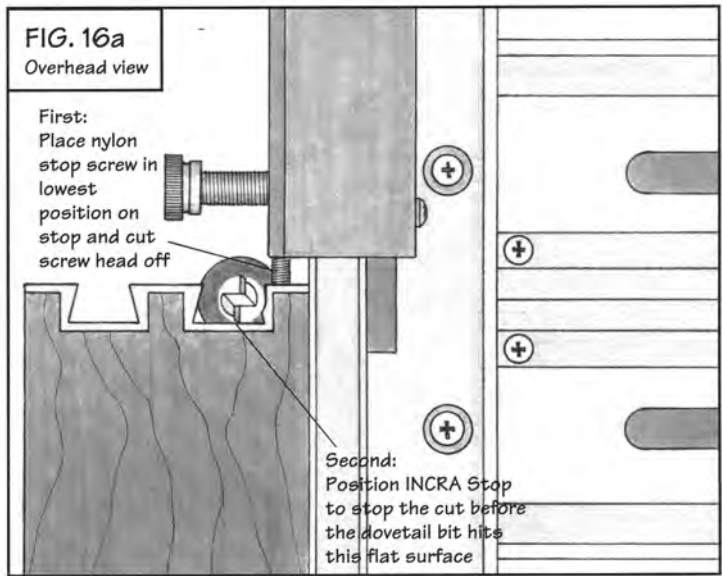
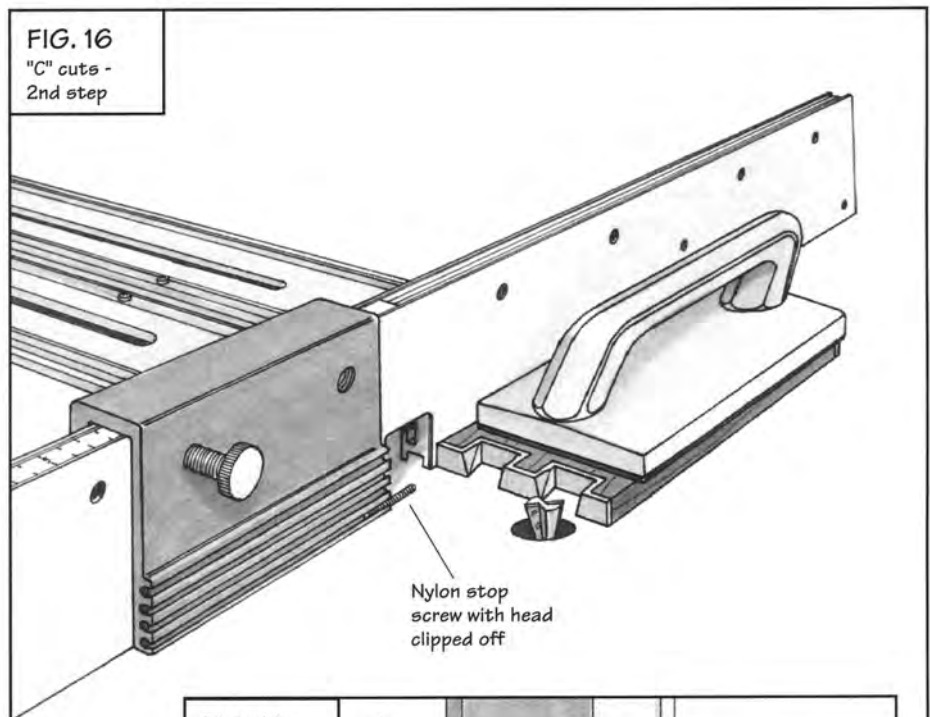

15 As you can see in Fig. 17, the cuts completed in Step 14 will leave a very small triangle of wood just outside the cutting arc of the dovetail bit. The final step to producing the Double-Double Through Dovetail is to remove this small piece of wood. This is easily accomplished by whittling off the triangle with a sharp pocket knife or chisel. Follow the cut created by the bit in Step 14 and cut straight back to the corner. The finished piece should look like the drawing in Fig. 17a.

16 You can now assemble your box. See pages 30-33 for techniques you can use to install a bottom in your box.

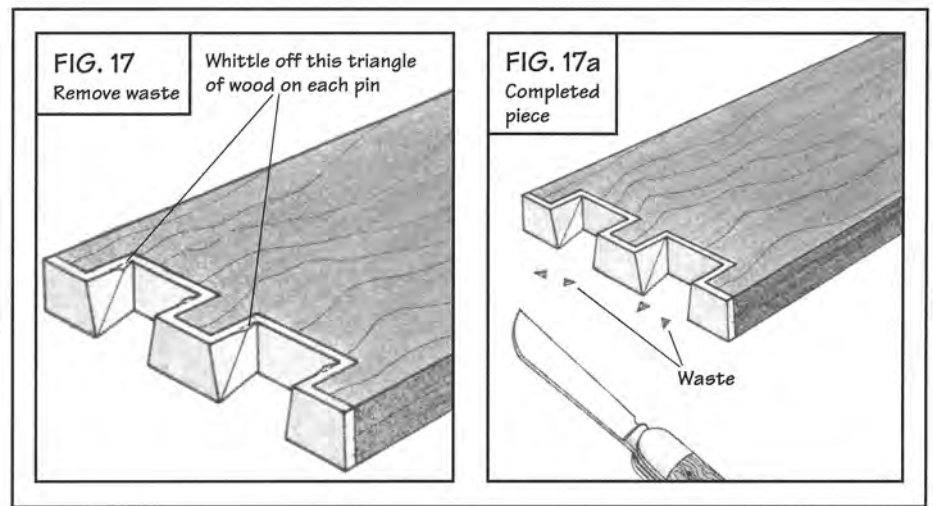

Formula for Success - INCRA Double-Double Through Dovetail

Here are some suggested stock widths and appropriate "center" cuts that you can use with the Double-Double Through Dovetail templates. These suggestions represent a positive entry point into this fascinating new joint and are by no means the only stock widths you can use.

Template - Double-Double Through Dovetail	
Stock Width	"Center" Cut
1-11/16"	8A
3"	3B
4-5/16"	8A
5-5/8"	3B

Interesting Variations

Box Joints and INCRA[®] Double Dovetails[™]

The templates for the Double-Double Through Dovetail were designed to serve triple duty. Used together following the technique previously described, they will produce the Double-Double Through Dovetail, but the templates can be used individually to produce other joints. Template ONE can be used to make a variably spaced box joint using a $\frac{3}{8}$ " straight bit. See Fig. 18. Template TWO can be used with a $\frac{1}{2}$ "-14° dovetail bit to produce an INCRA Double Dovetail, Fig. 19, or by following the technique described on pages 65-67, it can be used in making the Cornerpost Double Dovetail, Fig. 20. But that's not all! Pages 69-71 describe techniques for making another new joint using the Double-Double Through Dovetail templates - the INCRA Cornerpost Eagletail[™].

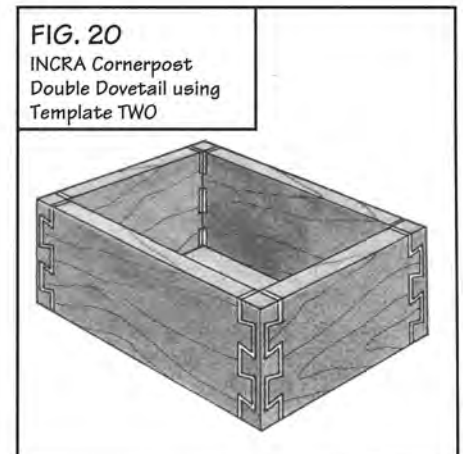
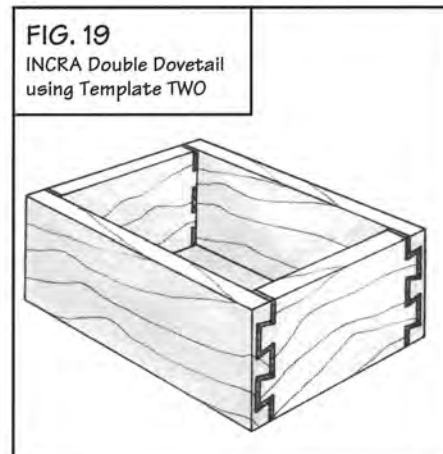
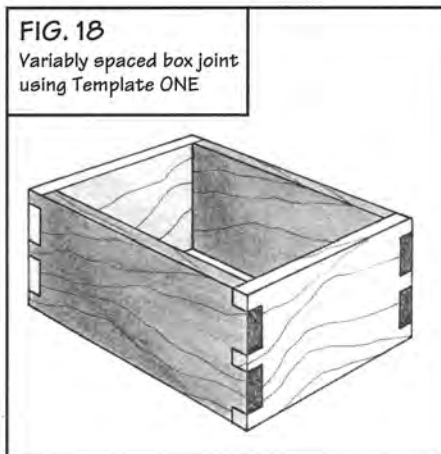

**INCRA®
DOUBLE-DOUBLE THROUGH DOVETAIL™**

INCRA DOUBLE-DOUBLE THROUGH DOVETAIL	5B	12A	11A	10A	4B	9A	8A	7A	3B	6A	ALIGN 5A	4A	2B	3A	2A	1A	1B	ONE
--------------------------------------------	----	-----	-----	-----	----	----	----	----	----	----	-------------	----	----	----	----	----	----	-----

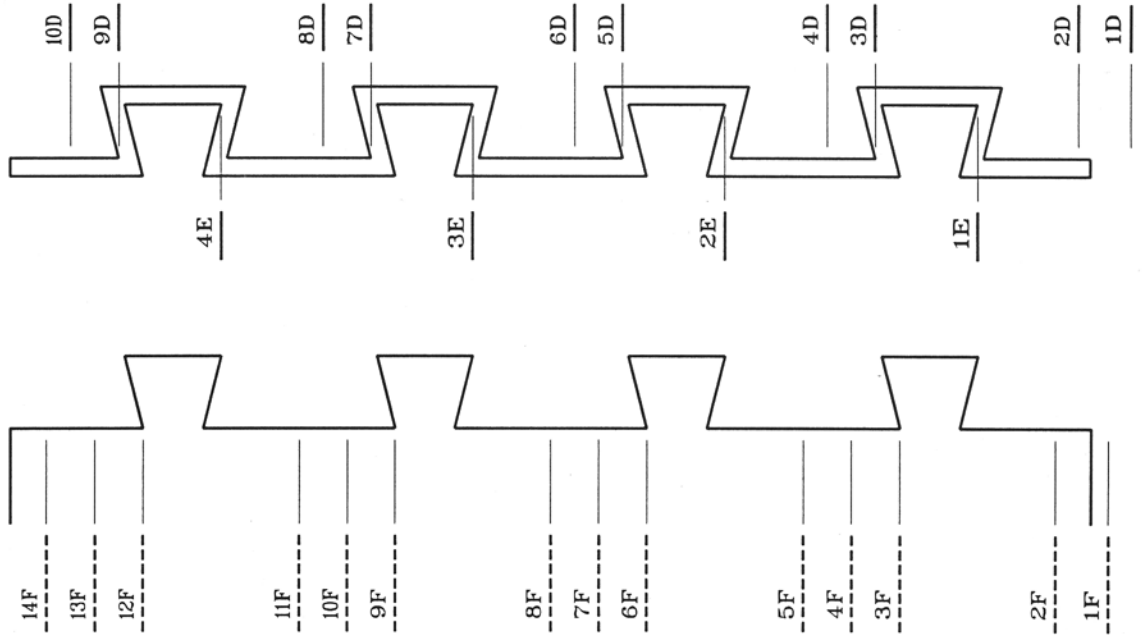
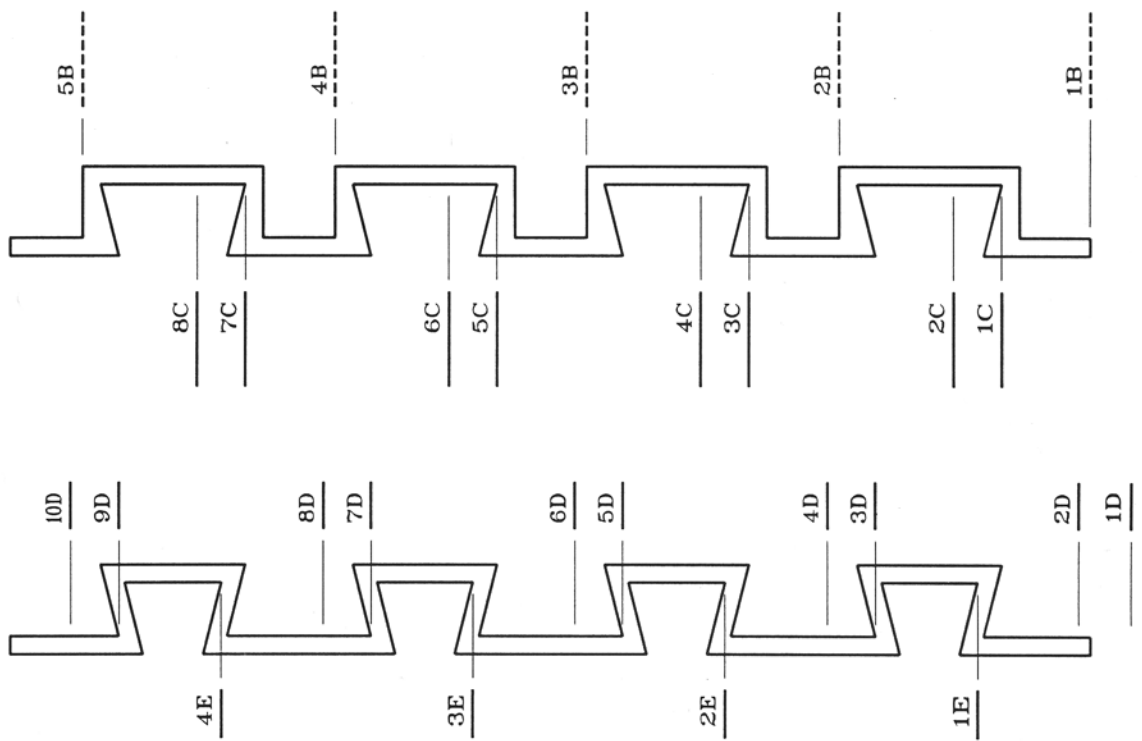
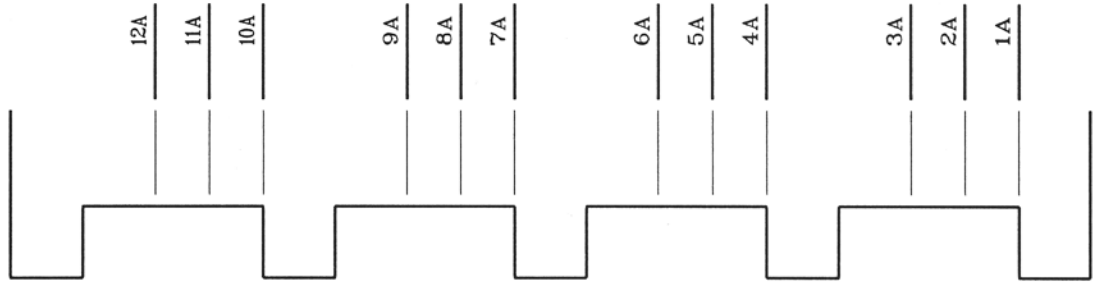

INCRA DOUBLE-DOUBLE THROUGH DOVETAIL	14F	10D	13F	9D	12F	8C	4E	7C	11F	8D	10F	7D	9F	3E	6C	5C	8F	6D	7F	5D	6F	ALIGN 4C	2E	3C	5F	4D	4F	3D	3F	2C	1E	1C	2F	2D	1F	1D	TWO
--------------------------------------------	-----	-----	-----	----	-----	----	----	----	-----	----	-----	----	----	----	----	----	----	----	----	----	----	-------------	----	----	----	----	----	----	----	----	----	----	----	----	----	----	-----

INCRA® Cornerpost Dovetail™

This decorative joint is very similar in construction to the INCRA Double Dovetail in that it requires a trim section that is cut and glued on in the same manner. The differences between this joint and the Double Dovetail appear in the final series of cuts used to join the side with the trim section to the remaining side.

I think the finished piece is quite dramatic. It is a very versatile joint that can be made with any of the standard dovetail templates using common stock thicknesses. Give it a try - you'll enjoy the results.

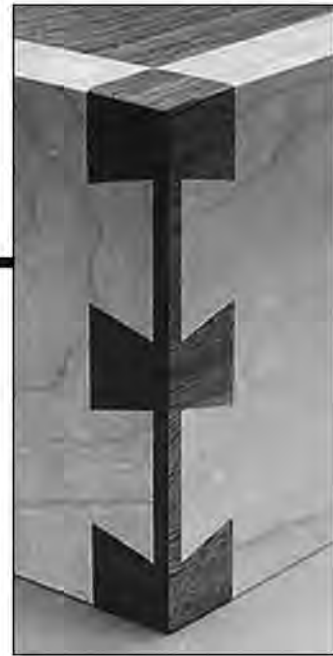

Initial Setup

1 Choose the dovetail template you wish to use and the corresponding dovetail bit. Install the dovetail bit in your router and set the depth of cut as described on pages 2-3 of the Master Reference Guide.

2 You will need six pieces of wood to make a box with this joint. Four pieces for the front/back and sides, one piece for the corner post section, and one piece for the "centering" process. Here are some rules regarding the width, thickness and length of the pieces:

WIDTH

All six pieces must be of equal width.

THICKNESS

Front/Back and Sides - These pieces must be at least $\frac{1}{16}$ " greater in thickness than the depth of cut set in Step 1 above. (For more information on selecting side stock thickness, see the chart on page 26.)

Cornerpost section - Must be equal in thickness to the front/back and sides.

"Centering" board - A piece of scrap stock $\frac{3}{4}$ " thick for all templates except DOV9 and DOVU. These two templates require a 1" thick board for centering.

LENGTH

Front/Back and Sides - The front/back pieces should be of equal length. The sides should both be of equal length.

Note: For more information on cutting the front/back and sides to length in order to produce a specific size box with Cornerpost Dovetail joinery see page 28.

Cornerpost section - 9" minimum when using templates DOV9, DOV10, DOVR, DOVS, DOVT, DOVU.* For all other templates the minimum length is 6".*

"Centering" board - 5" minimum*

* If the width of your stock exceeds this minimum, cut the length to match the width.

3 Choose a "center" cut on the template and, using the centering board, "center" your INCRA JIG using the method described on pages 22-24. In this joint the cornerposts are the pin sections. Remember the pin sections of any dovetails cut with INCRA JIG will always have a partial pin (solid wood)

on the inside and outside edges. Accordingly, the tail sections will always have open grooves on the inside and outside edges. See Fig. 1. When choosing a "center" cut, use the full-size diagram in your template book to ensure the appropriate cuts. Also, see the "Formula for Success" section on page 64 for some suggested stock widths, "center" cuts, and corresponding pin and tail designations for use with the DOV1 and DOVJ Templates.

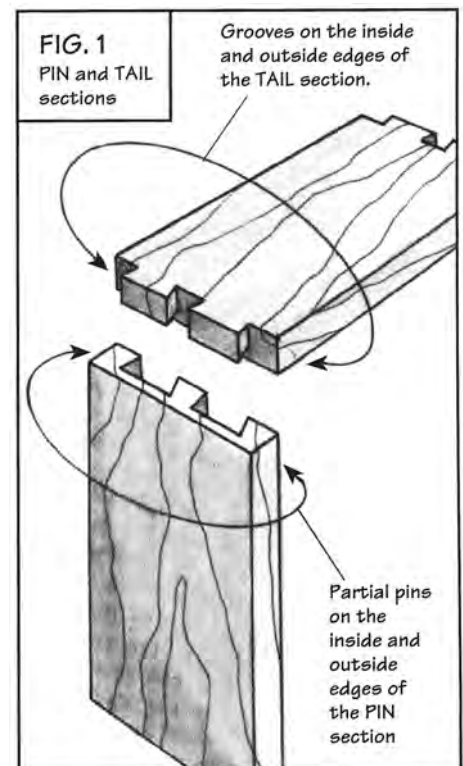

SEE ALSO

Centering	22
Stock Thickness, Router Bit and Template Selection	25
Boxes Made to Order	27

Cutting the Tail Sections

4 Cut a dovetail-shaped rabbet on both ends of either the sides or the front/back pieces. **ONLY TWO OF THE FOUR PIECES NEED THIS RABBET!** Cut a light scoring pass ($1/32$ ") and then two or three light subsequent passes, moving the fence back for each pass, until you have reached the rabbet width required for the template chosen. (Fig. 2.)

5 Place the front/back and the side pieces on the right angle fixture as shown in Fig. 3. Starting with a light scoring pass, make the tail series of cuts.

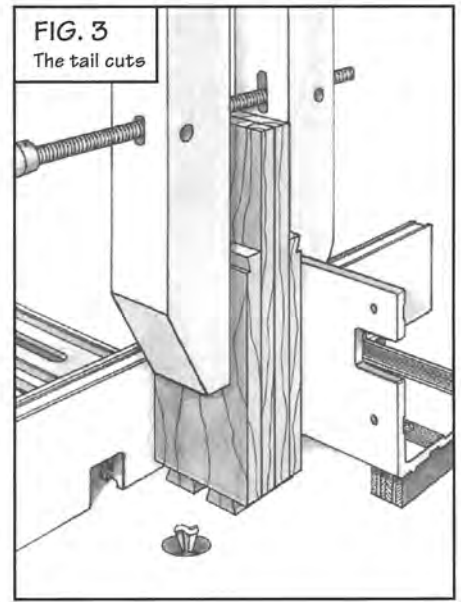

Cutting the Cornerpost Sections

6 Make the pin cuts along the length of the cornerpost section starting with the outside groove and moving in toward the fence. However, whenever a groove is wider than the bit, always cut the inside of each groove first, and then the outside, to avoid grabbing. Be sure to use a rubber soled push block. Fig. 4.

7 At the table saw using a sliding crosscut box or a miter gauge with an auxiliary fence, crosscut four pieces from the cornerpost section.

See Fig. 5. Each piece should be about $1/32$ " longer than the thickness of the side stock to allow for flush belt sanding in Step 9.

8 Glue the cornerpost pieces to both ends of the two non-rabbeted side or front/back pieces. Fig. 6. Allow to dry about one hour.

9 Belt sand the cornerpost sections flush with the faces of the two side or front/back pieces.

10 The two pieces with the cornerpost sections attached can now be cut as standard pin sections to mate with the two rabbeted pieces. Position an INCRA Stop on the outfeed side of the fence with the nylon screw as close as possible to the bit. Again make the pin cuts, this time with the stock face down on the table, Fig. 7. Be sure to use a rubber soled push block. Dry assemble the box and adjust the length of these last pin cuts as necessary by moving the INCRA Stop away from the bit. Recut if needed.

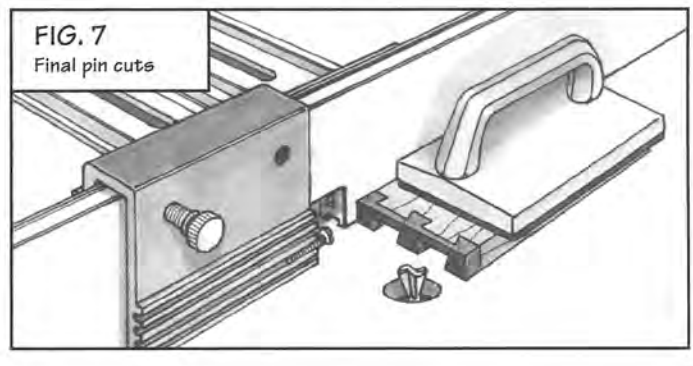
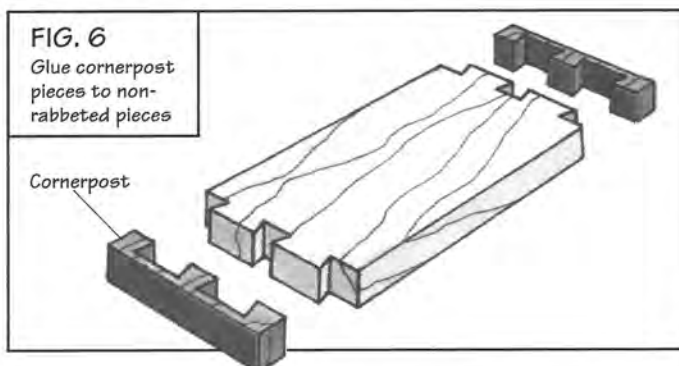
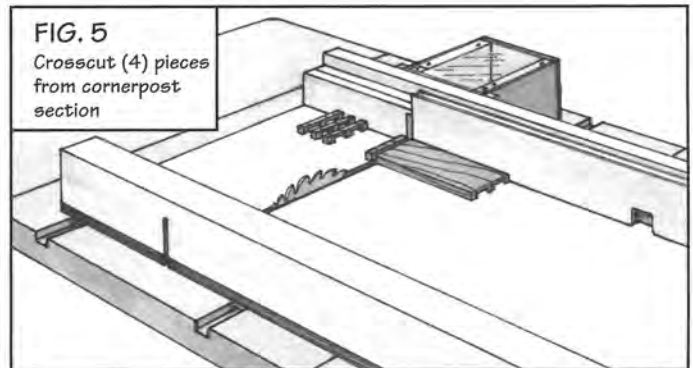
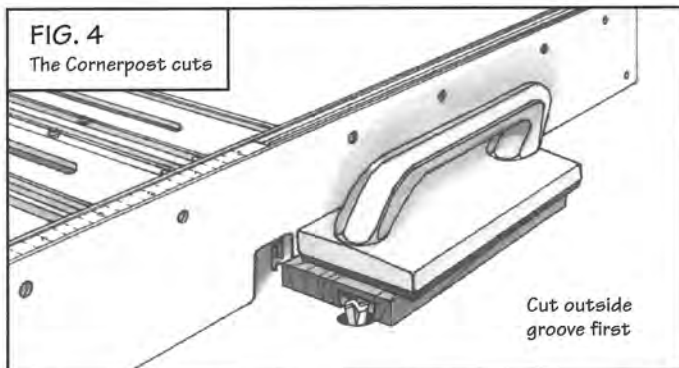

Formula for Success - INCRA Cornerpost Dovetail

Here are some suggested stock widths, "center" cuts, and the corresponding pin and tail cuts that you can use with the DOV1 or DOVJ templates. These two templates require the use of a $1/2$ " or $17/32$ " 14° dovetail bit. The suggestions are intended to present a positive starting point for use with the Cornerpost Dovetail technique and are by no means the only stock widths you can use, nor are these the only templates. Remember, **any** template that can be used to produce a half-blind dovetail can also be used to produce a cornerpost dovetail. There are literally hundreds of stock width and pattern combinations. Stock that is $1/2$ " thick will work well for either bit; however, you could also use $3/8$ " thick stock if you are using the $1/2$ " 14° bit.

TEMPLATE - DOV1

Stock Width	"Center" Cut	Tail Cuts	Pin Cuts
2-7/8"	5B	A	B
3-3/4"	5B	B	A
4-5/8"	5B	A	B
5-1/2"	5B	B	A
6-3/8"	5B	A	B
7-1/4"	5B	B	A

FIG. 8
Cornerpost Dovetail

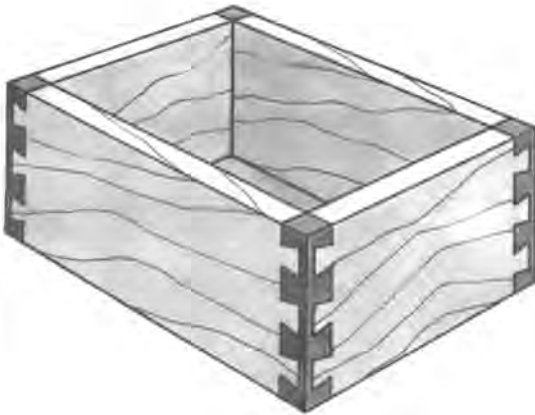

TEMPLATE - DOVJ

Stock Width	"Center" Cut	Tail Cuts	Pin Cuts
2-7/8"	10B	A	B
3-3/4"	10B	B	A
4-5/8"	10B	A	B
5-1/2"	10B	B	A
6-3/8"	10B	A	B
7-1/4"	10B	B	A
8-1/8"	10B	A	B
9"	10B	B	A

INCRA® Cornerpost Double Dovetail™

Here's an attractive variation of the Cornerpost Dovetail that can be made using any of the INCRA Double Dovetail templates. It transforms the beautiful Double Dovetail into a decorative joint visible from all four sides of the box.

The sides of this joint begin with the addition of a trim section just as in the Double Dovetail. The cornerpost is then added to two of the sides and the final cuts are made. Those of you who are already making the Double Dovetail will find this joint quite easy. If you would like to see a specific application of this corner joint, it is the featured joinery for the **Jewelry Box** project shown on pages 138-148.



Initial Setup

1 Choose the Double Dovetail template you wish to use and the corresponding dovetail bit. Install the dovetail bit in your router and set the depth of cut as described on pages 2-3 of the Master Reference Guide.

2 You will need seven pieces of wood to make a box with this joint. Four pieces for the front/back and sides, one piece for the cornerpost section, one piece for the trim section, and one piece for the "centering" process. Here are a few rules regarding the width, thickness and length of the pieces:

WIDTH

All seven pieces must be of equal width

THICKNESS

Front/Back and Sides - These pieces

must be at least $\frac{1}{16}$ " **greater** in thickness than the depth of cut set in Step 1. (For more information on selecting side stock thickness, see the chart on page 26.)

Trim section - $\frac{3}{4}$ "

Cornerpost Section - Equal in thickness to the front/back and sides

"Centering" board - $\frac{3}{4}$ " (scrap stock)

LENGTH

Front/Back and Sides - The front/back pieces should be of equal length. The two side pieces should be of equal length.

Note: For more information on cutting the front/back and sides to produce a specific size box when using the Cornerpost Double Dovetail joint, see page 29.

Trim section - Using templates IDD1, IDD2, IDDA, IDDB, IDDC, IDDD, IDD3 - 9" minimum*

Using template IDDF ($\frac{5}{8}$ "-7° dovetail bit) - 11" minimum

Cornerpost section - Using templates IDD1, IDD2, IDDA, IDDB, IDDC, IDDD, IDDE - 6" minimum*

Using template IDDF ($\frac{5}{8}$ "-7° dovetail bit) - 8" minimum*

Centering board - 5" minimum*

*If the width of your stock exceeds this minimum, cut the length to match the width.

Design Tip

COLOR

Here are a few color contrast suggestions you can use when making this joint:

- 1** Front/Back & Sides - use a light colored wood (maple, birch, ash)
Cornerpost Section - same as above
Trim Section - use a dark colored wood (walnut, cherry or one of the many dark exotics)
See photo above.
- 2** Front/Back & Sides - use a dark colored wood (walnut, cherry or one of the many dark exotics)
Cornerpost Section - same as above
Trim Section - use a light colored wood (maple, birch, ash)
See Jewelry Box photo on page 138.
- 3** In each of the above examples, the cornerpost is from the same species as the front/back and sides. What about the introduction of a third species for the cornerpost? You could then use this third color wood in the lid frame to bring it all together.

SEE ALSO

Centering	22
Boxes Made to Order	27
Stock Thickness, Router Bit and Template Selection	25
Double Joinery Without a Surface Planer	53
Jewelry Box	138

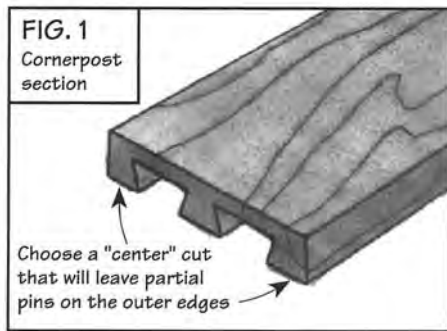

3 "Center" using one of the INCRA Double Dovetail templates. The cornerpost section will be the pin cuts (the "D" cuts on the template). Make sure that your center cut will leave the cornerpost section with partial pins (solid stock) on the outer edges when cut. See Fig. 1 and Fig. 8. Use the full-scale plans in your template book to help with "center" cut selection. Also see the "Formula for Success" on page 68 for some suggested "center" cuts and stock widths for use with the IDD1 and IDDD templates.

4 Place all four front/back and side pieces with a backing board on the right angle fixture and make the "A" cuts on both ends. (See Fig. 2.) Before removing the pieces from the right angle fixture, mark the sides of all pieces where they touch the fence.

5 Make the "B" cuts along the length of the trim section stock. (See Fig. 3.) Be sure to use a rubber soled push block for these cuts.

6 At the table saw, using a crosscut box or a miter gauge with an auxiliary fence, crosscut eight pieces from the trim section. Each piece should be slightly longer than the thickness of the front/back and side stock. See Fig. 4.

7 Glue the trim section pieces to both ends of the front/back and side pieces and allow to dry for about an hour. All four boards will have trim pieces on both ends.

8 Belt sand the trim sections flush with the faces of the front/back and side pieces.

9 Since the trim sections were cut from $\frac{3}{4}$ " stock, place a mark on the trim section $\frac{3}{32}$ " from the outermost glue joint. See Fig. 5. Using the crosscut box at the table saw, cut each of the ends off to the mark. (For more on this technique see "Double Joinery Without a Thickness Planer" on pages 53-54.)

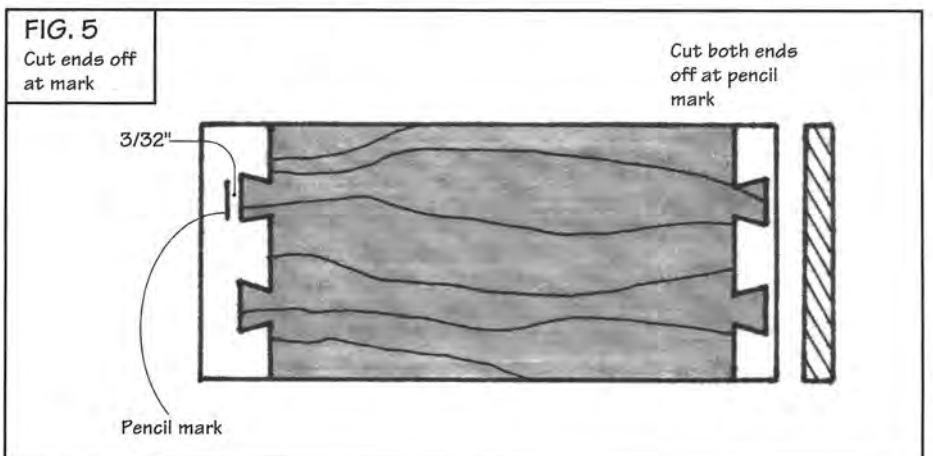
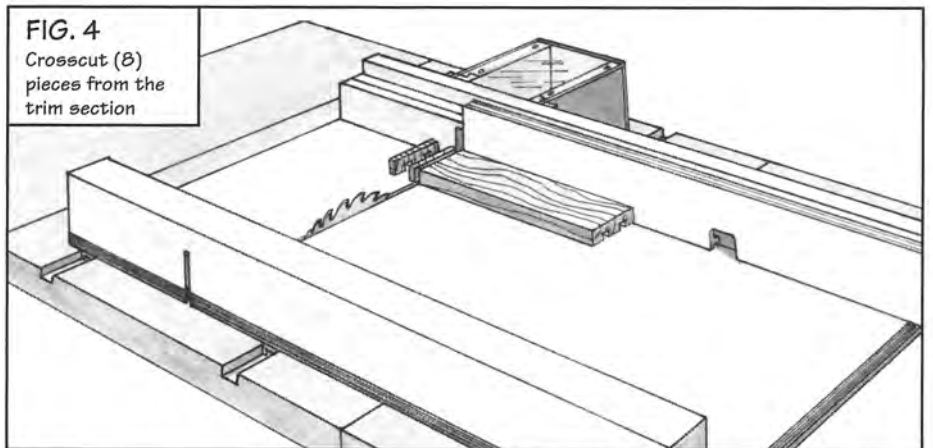
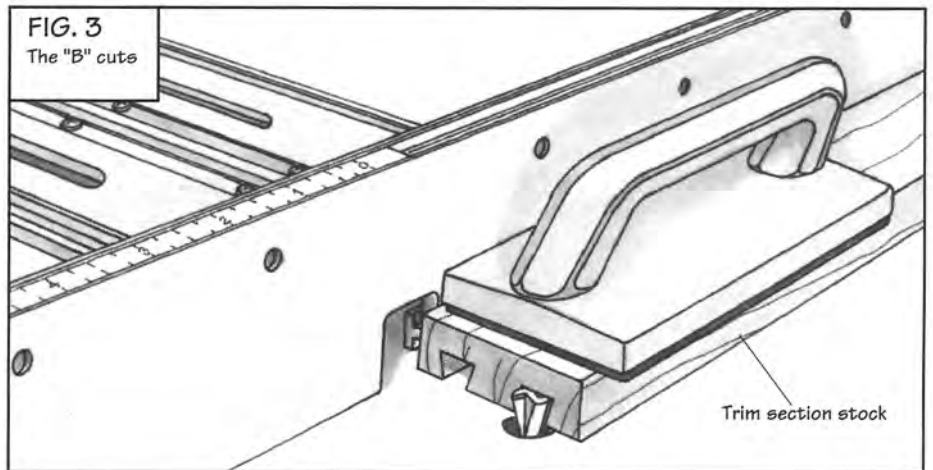
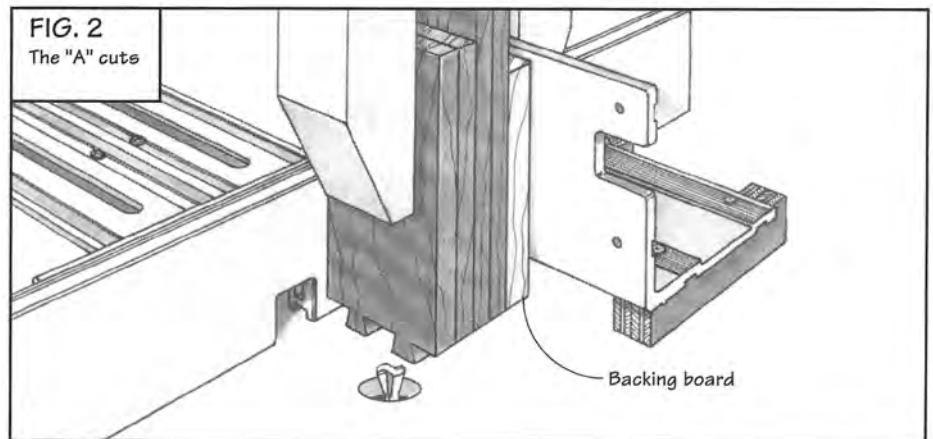

10 Cut a dovetail shaped rabbet on both ends of either the sides or the front/back pieces. **ONLY TWO OF THE FOUR PIECES NEED THIS RABBET!** Cut a light scoring pass ($1/32$ ") and then two or three light subsequent passes, moving the fence back for each pass until you have reached the rabbet width required for the template chosen. (Fig. 6.)

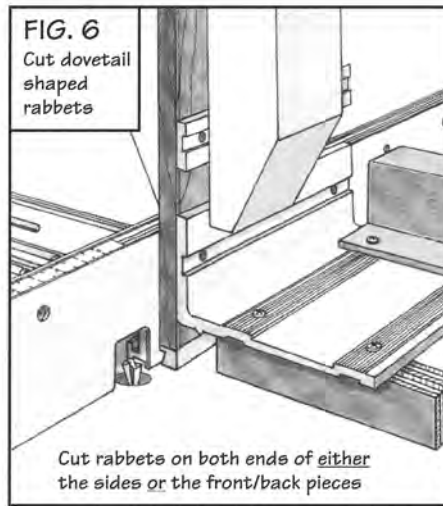

11 Place the front/back and the side pieces on the right angle fixture as shown in Fig. 7. Make sure the "fence edge" marked in Step 4 is placed adjacent to the fence. Starting with a light scoring pass, make the "C" cuts.

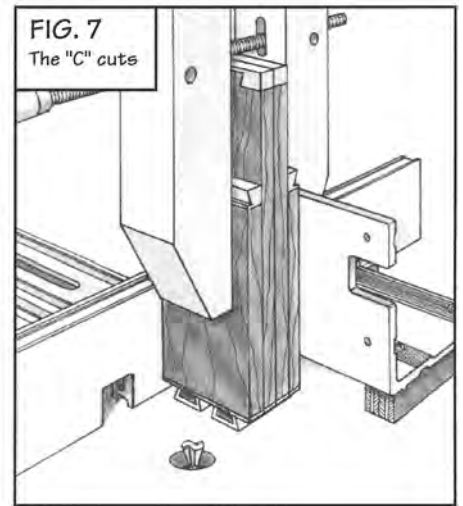

Adding the Cornerpost Section

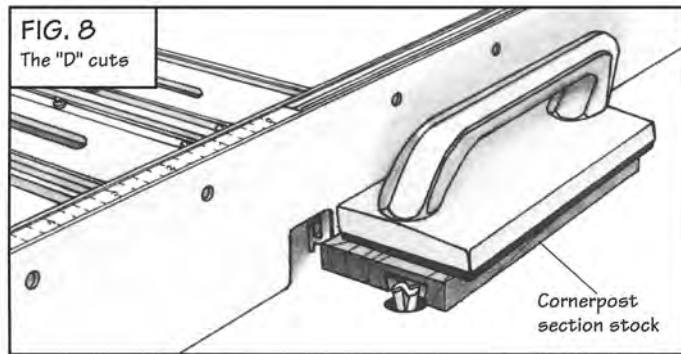

12 Make the "D" cuts along the length of the cornerpost section starting with the outside groove and moving in toward the fence. See Fig. 8. Again, make sure to use a rubber soled push block.

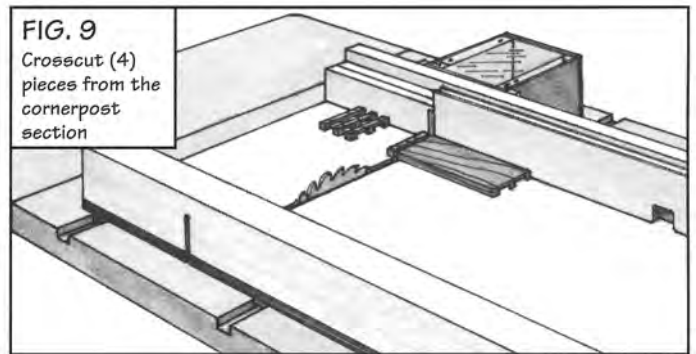

13 At the table saw, crosscut four pieces from the cornerpost section. Each piece should be just slightly longer than the thickness of the front/back and side pieces. (See Fig. 9.)

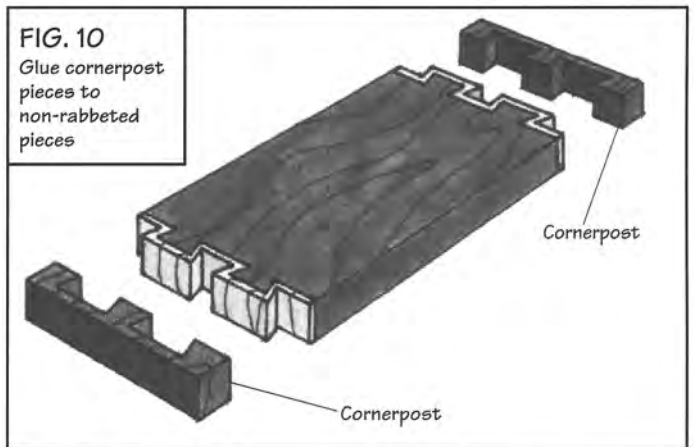

14 Glue the cornerpost pieces to both ends of the two non-rabbeted side or front/back pieces. See Fig. 10. Allow to dry for about one hour.

15 Belt sand the cornerpost sections flush with the faces of the two side or front/back pieces.

16 The two pieces with the cornerpost sections attached can now be cut as standard pin sections to mate with the two rabbeted pieces. Position an INCRA Stop on the outfeed side of the fence with the nylon screw as close as possible to the edge of the bit. This will produce a cut that is a little too short. Make the "D" cuts on both ends of the two pieces as shown in Fig. 11. Check the fit with the tail sections. Move the INCRA Stop away from the bit to lengthen the pin cuts as necessary for a flush fit.

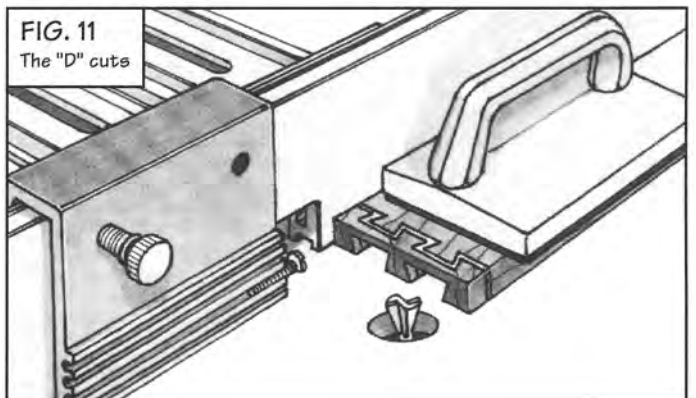

Formula for Success - Cornerpost Double Dovetail™

Here are some suggested stock widths and appropriate "center" cuts that you can use with the IDD1 or IDDD templates. You'll need a $\frac{1}{2}$ " or $\frac{17}{32}$ " 14° dovetail bit for use with these templates. The suggestions represent a positive entry point into this fascinating new joint and are by no means the only stock widths you can use, nor are these the only templates. As you learn more about your INCRA JIG and its capabilities, you'll find that there are hundreds of pattern and stock width combinations at your disposal. The templates mentioned will work on any stock thickness of $\frac{1}{2}$ " or greater, but I think it looks best on $\frac{1}{2}$ " stock.

TEMPLATE - IDD1

Stock Width	"Center" Cut
2-5/8"	4C
3-3/4"	3B
4-7/8"	4C
6"	3B

TEMPLATE - IDDD

Stock Width	"Center" Cut
2-5/8"	8C
3-3/4"	7B
4-7/8"	8C
6"	7B
7-1/8"	8C
8-1/4"	7B

FIG. 12
INCRA Cornerpost
Double Dovetail

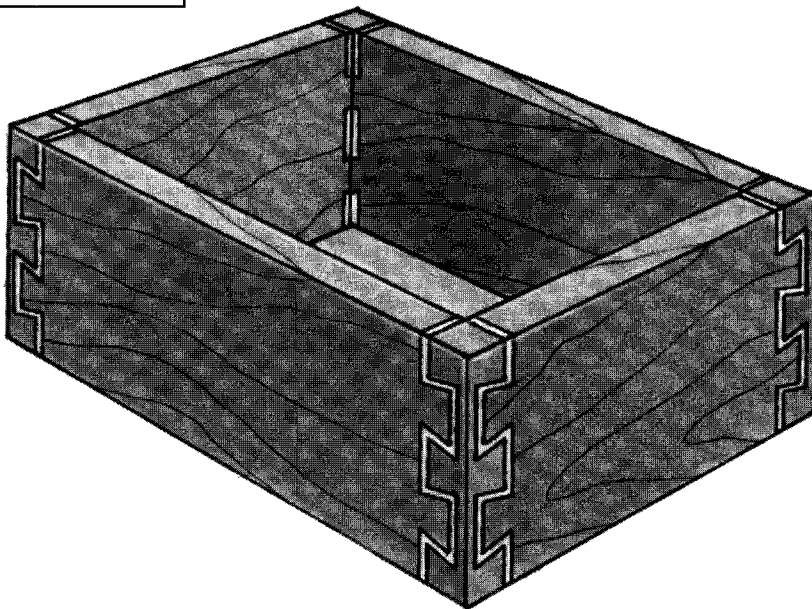

INCRA® Cornerpost Eagletail™

Fig. 1 shows a unique variation on the Cornerpost Dovetail (shown on pages 62-64) that uses cuts A, B, C and D on the Double-Double Through Dovetail templates. You'll need six pieces of wood to make a box featuring this joint. Four pieces for the front/back and sides, one piece for the cornerpost section, and one piece for the "centering" process. Here are some rules regarding the width, thickness and length of the pieces:

WIDTH

All six pieces must be of **equal** width. (See the chart on page 70 for a few suggested stock widths and corresponding "center" cuts for use in making this joint.)

THICKNESS

Front/Back and Sides - These pieces must be at least $\frac{1}{16}$ " **greater** in thickness than your dovetail bit's depth of cut. $\frac{1}{2}$ " to $\frac{5}{8}$ " stock should work fine.

Cornerpost section (box joint trim section) - must be **Equal** in thickness to the front/back and sides.

Centering board - $\frac{3}{4}$ "

LENGTH

Front/Back and Sides - The front/back pieces should be of equal length. The sides should be of equal length.

Note: For more information on cutting the front/back and sides to length in order to produce a specific size box when using the Cornerpost Eagletail joint, see page 28.

Cornerpost section (box joint trim section) - 6"

"Centering" board - 5"

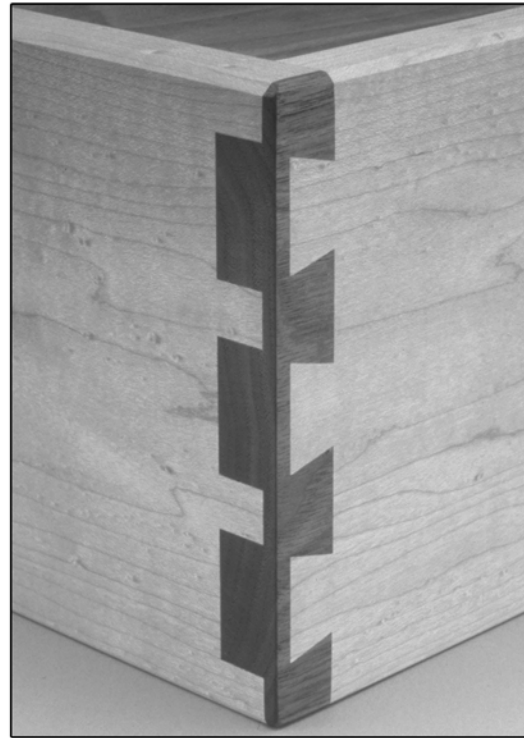
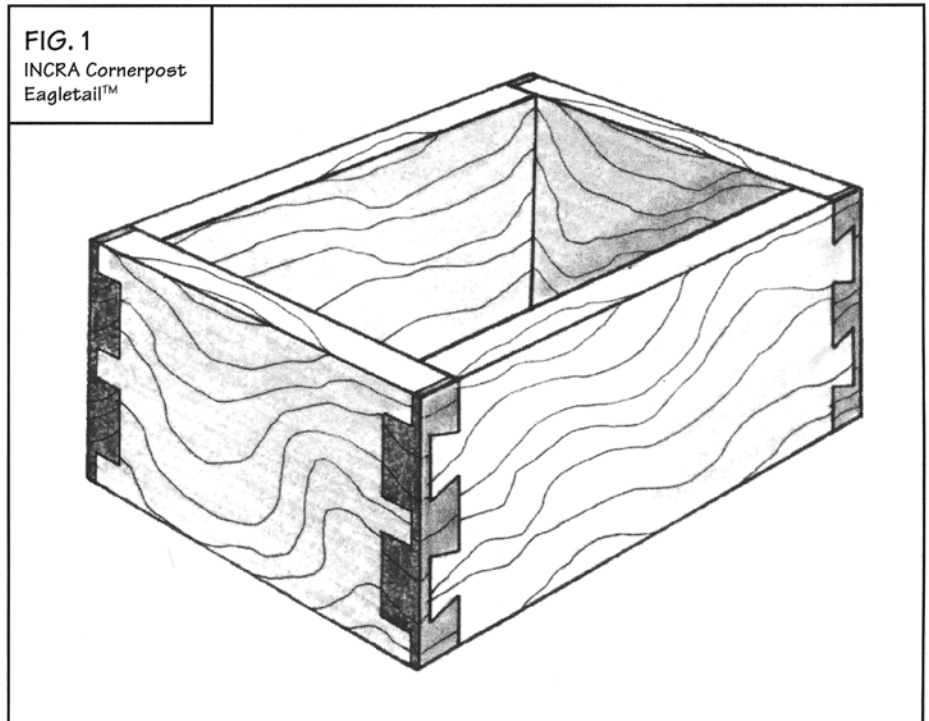

FIG. 1
INCRA Cornerpost
Eagletail™



SEE ALSO

Centering	
Boxes Made to Order	27
INCRA Double-Double Through Dovetail	55
INCRA Cornerpost Dovetail	62

Required Bits

$\frac{1}{2}$ " - 14° dovetail
 $\frac{3}{8}$ " straight bit



Cutting the Joint

- 1** Follow the instructions shown on page 56 for determining your dovetail bit depth of cut; then follow Steps 1 through 7 in the **INCRA Double-Double Through Dovetail** section on pages 57-58.
- 2** After the glue has set on the two box jointed sides, sand the cornerpost flush with the faces of the boards. It is not necessary to cut off the ends of the box jointed pieces.
- 3** Cut a dovetail-shaped rabbet on both ends of the remaining two uncut sides as shown in Fig. 2. Start with a light $1/32$ " scoring pass and then make three subsequent passes, each time moving the fence back $1/16$ " for a total rabbet width of $7/32$ ".
- 4** Clamp the two rabbeted boards to the right angle fixture as shown in Fig. 3 and, beginning with a light $1/32$ " scoring pass, make the "D" cuts.
- 5** The two pieces with the cornerpost sections attached can now be cut as standard pin sections to mate with the two rabbeted tail sections. Position an INCRA Stop on the outfeed side of the fence with the nylon screw as close as possible to the router bit. With the stock face down on the table as shown in Fig. 4, make the stopped "C" cuts. Be sure to use a rubber soled push block. Dry assemble the box and check the fit. If the tails don't fit flush with the ends of the pin sections, lengthen the pin cuts by moving the INCRA Stop away from the bit and re-cut as necessary.
- 6** You can now assemble your box. See pages 30-33 for techniques you can use to install a bottom in your Cornerpost Eagletail box.

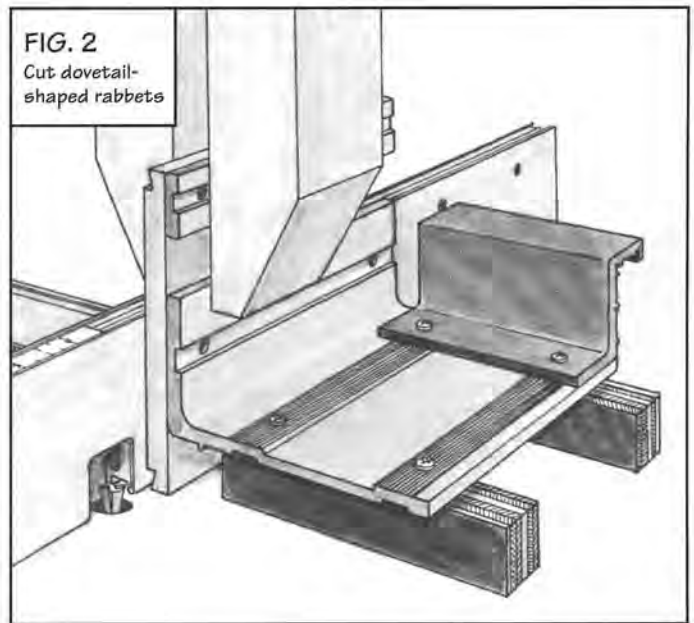

FIG. 2
Cut dovetail-shaped rabbets

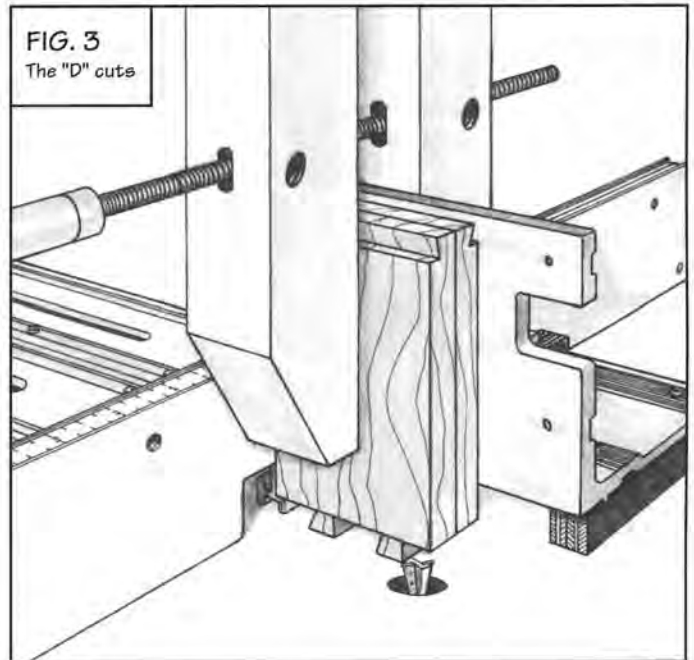

FIG. 3
The "D" cuts

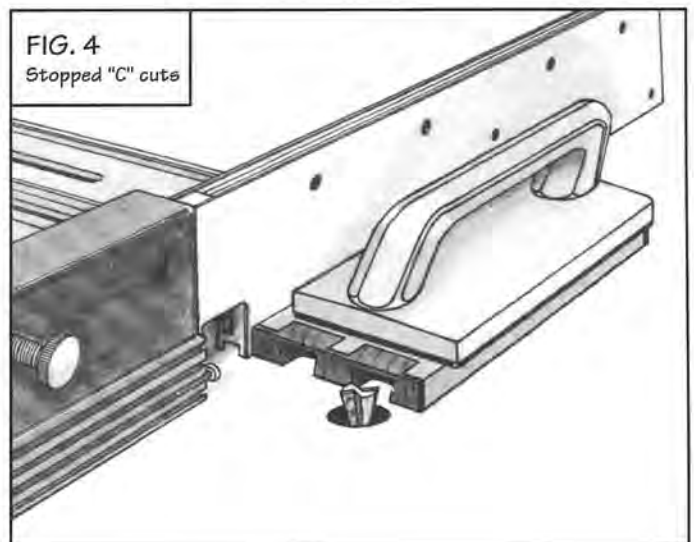

FIG. 4
Stopped "C" cuts

Formula for Success - INCRA Cornerpost Eagletail™

Here are some suggested stock widths and appropriate "center" cuts that you can use for the Cornerpost Eagletail joint. These suggestions represent a positive entry point into this fascinating new joint and are by no means the only stock widths you can use.

Template - Double-Double Through Dovetail	
Stock Width	"Center" Cut
1-11/16"	8A
3"	3B
4-5/16"	8A
5-5/8"	3B

INCRA[®] CORNERPOST EAGLETAIL™

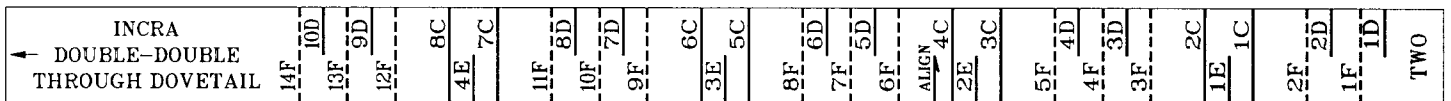
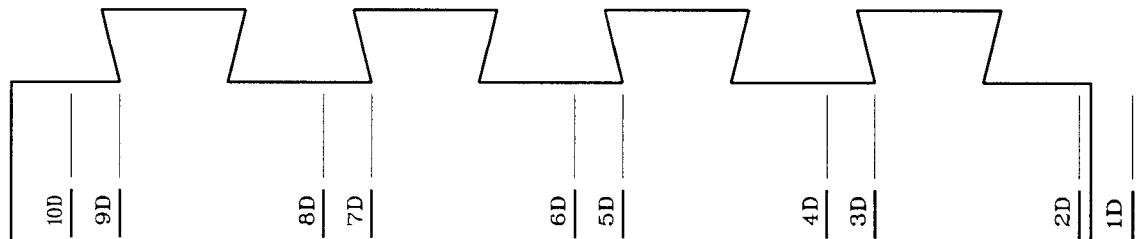
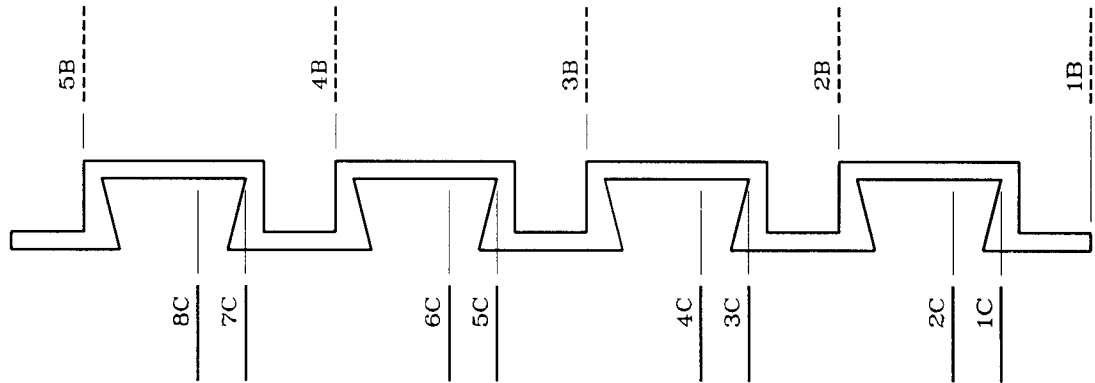
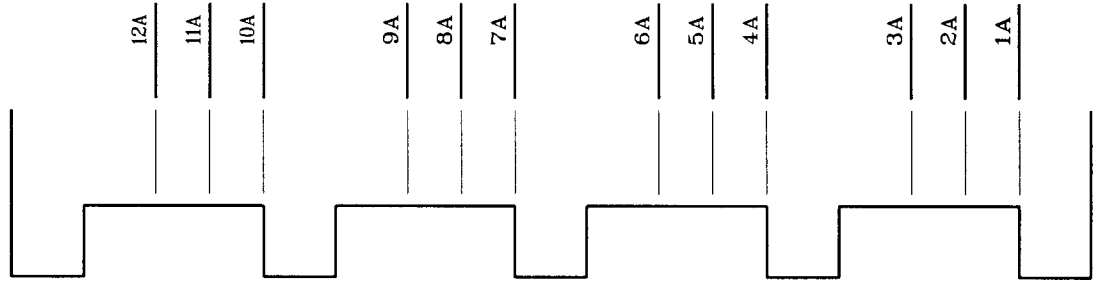
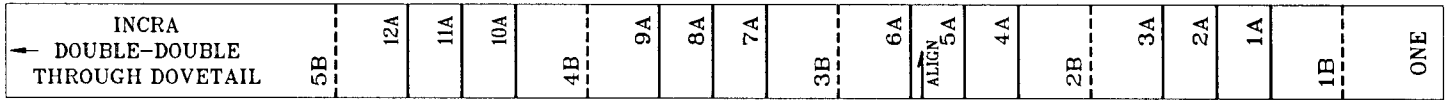

NOTE: THE INCRA CORNERPOST EAGLETAIL USES THE SAME TEMPLATES AS THE INCRA DOUBLE-DOUBLE THROUGH DOVETAIL.