



Plans from Shopsmith's Web Magazine





2000 Archive

GRANDFATHER CLOCK



The overall height of the clock is just slightly taller than the height of a typical door (about 6-feet, 8-inches). That way, it'll be a little shorter than a classic 7-foot clock, but will still look good in a typical American home with 8-foot ceilings.



You will need about 30 board feet of lumber to build the clock., but buy about 30% more than what you'll actually need to cover for bad wood, extra pieces for making set-ups and, of course, mistakes.

Take the time to draw full-size profile details on all the turnings and moldings. I'm sure these will change slightly as you do the actual milling and turning, but at least you know what you're aiming at.

The Hood Assembly

The three basic units for the clock: the Hood, the Waist and the Base. Start with the Hood, first make the sides and the dial face frame, which is a little challenging. Grain direction will make this arched piece fragile, so don't cut the arch, yet. Cut joinery, dry assembled frame and set it in grooves between the two sides to get the width for the scroll board and the size of the hood base.

Cut the spindle stock. Dowel all the pieces together dry: the scroll board and sides to the spindle stock to make the scroll board assembly. No gluing yet. No turning yet. The spindles and finials will come from the same size stock, so cut them at the same time. Use a carbide-tipped blade for sizing cuts. Reserve a hollow-ground blade for the joinery that will come later.

The scroll board and base are done with the unturned spindle and finial stock blocked in between them for position. Now, you can figure some rough lengths: dimensions of the lower hood moldings. This is definitely a challenging project! A lot of final fitting. Some really tight tolerances. Use a rabbeting plane to fit and clean up the rabbets on the door.

Cut the sound ports on the hood sides with a scroll saw piercing cut. Then use a hand-held router to form the edge and hand-carve the inside corners to make them look as if they are mitered.

Start the lathe work. Work from the end of the spindle toward the middle — large diameters first, then small ones — less chatter and "whipping" that way. Mark and turn a piece of scrap first — that gives you a full-size model and a three-dimensional, mental image of what you was wanting on the cherry stock. By the time you are done turning the four spindles, you will have the pattern memorized.

Sand on all four spindles came after you are done turning the fourth one. If you make a small mistake on the last spindle, go back, adjust the others, then sand them all at once.



Do not drill the ends for the joinery of the spindles to the finials, yet. That would make it real hard to get them back on the lathe for the final sanding and finishing to come later.

Start from the bottom of the hood and worked your way up. From the simplest to the more difficult. From the "cream" of the stock reserved at the very beginning for the thinner, more delicate moldings, start to mill the moldings you want. Avoid trying to use "curly", figured stock. It looks great, but anything less than straight-grained wood can be very difficult to work on the molder or shaper.

In all the milling, try to use reasonably large pieces of stock ("blanks") so that forming an edge on it would be as safe as possible. The more "gripper" you have the better. After running the blanks through the molder or shaper, cut the molding away from the edges of the blanks.

The door frame molding is real delicate. Cut the contour of the door frame in a wide board, then use a shaper with rub collars and a starter pin in your table insert — no fence. The board is extra long so you can cut all the molding you will need. After shaping, resaw the board and belt-sand the back side. Then cut the molding off with your bandsaw and smooth the top side of the arched molding on a disc sander at a slow speed, using a fine grit paper.

For the gooseneck molding and its matching sides, start with the sides. That way, you can machine the 1-5/8-inch x 1-5/8-inch stock with molding knives . . . cut the cove on the table saw then hand-carve the cove in the gooseneck portion to match.

The gooseneck molding on the top of the hood is a very big challenge. you end up gluing up the stock like stairsteps, then hand carve the curved cove with a 1-inch lathe gouge (see Figure 1). Shape the outer edges on the shaper first, glue the pieces together, then dive in on the handwork.



Gooseneck portion of the scroll board molding requires handwork. A sharp, 1-inch lathe gouge can do the job.

Figure 1

After milling all the molding, set it aside. Final sand and finish the spindles and finials. To protect the areas that will need to take glue, apply masking tape. Then, drill the holes in the ends of them.



Glue together the scroll board, spindles, sides and also the base. After sanding, get the measurements for the moldings. Use an enlarged, shop-made miter gauge extension to cut the miters on the arched door molding (see Figure 2 below).



A tall, oversized miter gauge extension helped a lot when cutting the arched molding.

Figure 2

The same miter gauge extension with a nail placed strategically in it helps to hold the gooseneck molding while you cut the miters in it. Use the disc sander to achieve the final fit on all the miters. Here again, a rabbeting plane comes in handy to final form the corners after gluing the miters. Even though it's part of a classic technique to use brads or small nails to attach the moldings, use glue alone.

Get the knife hinge, pull and catch for the door. Hang the door so it swings hinged from the right (called a left-hand door).

The Grandfather Clock Hood Assembly

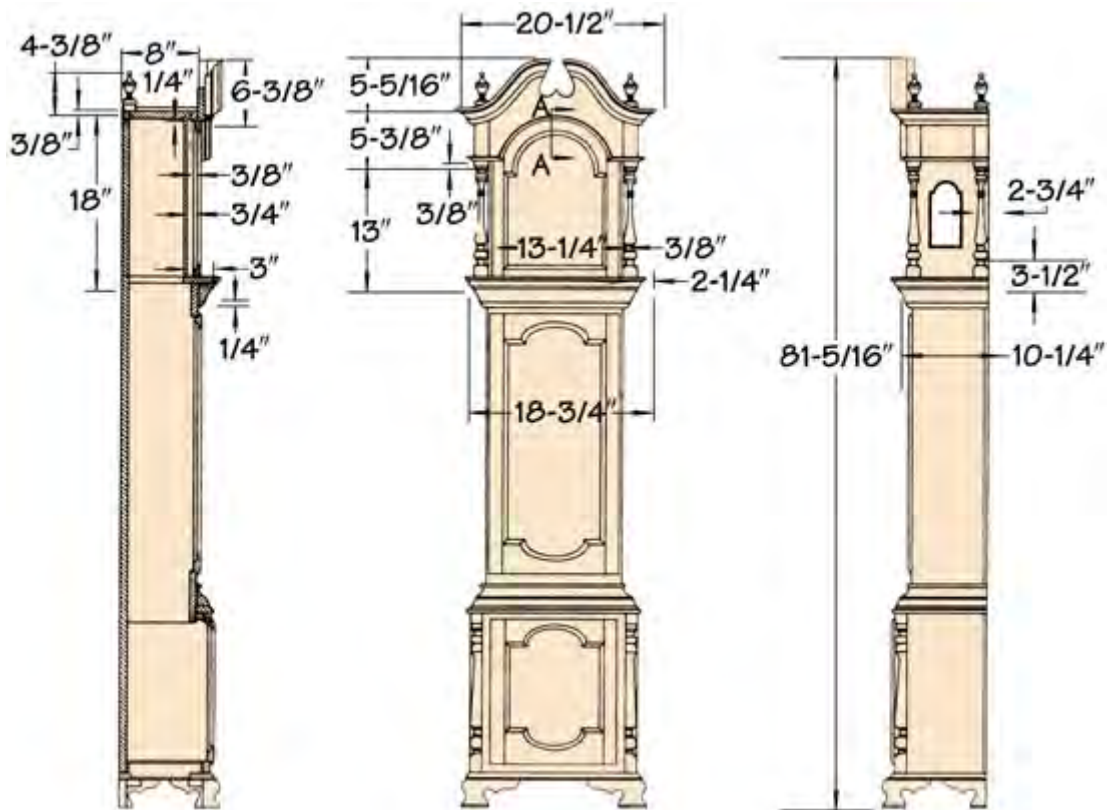

The Grandfather Clock Dial Frame

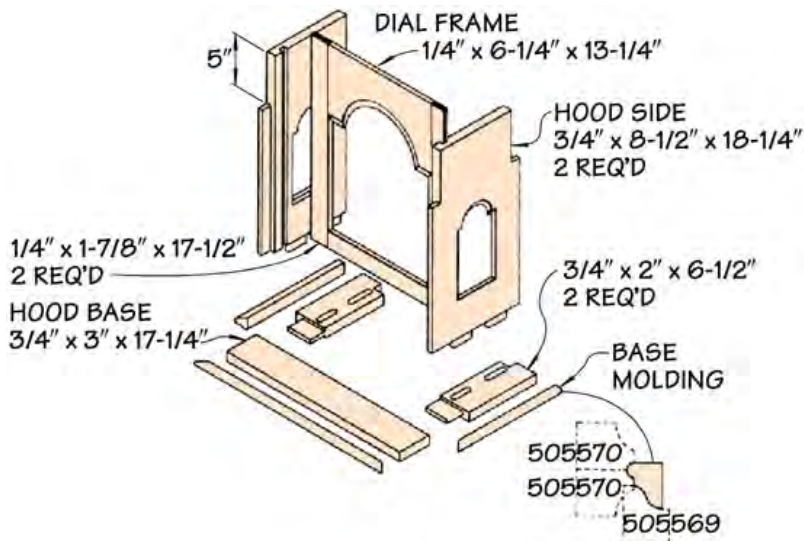

The Grandfather Clock Finial and Spindle Pattern

1 SQUARE = 1/4"

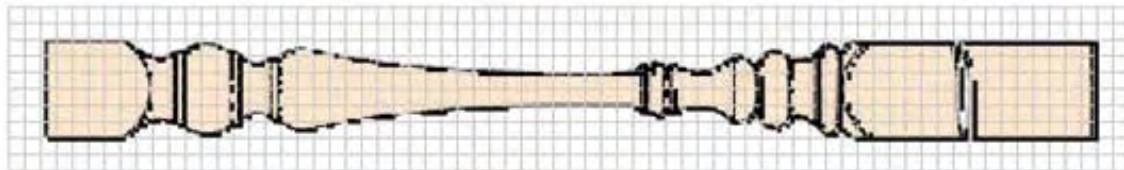
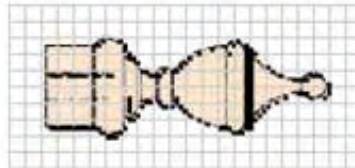

The Grandfather Clock Arch Pattern

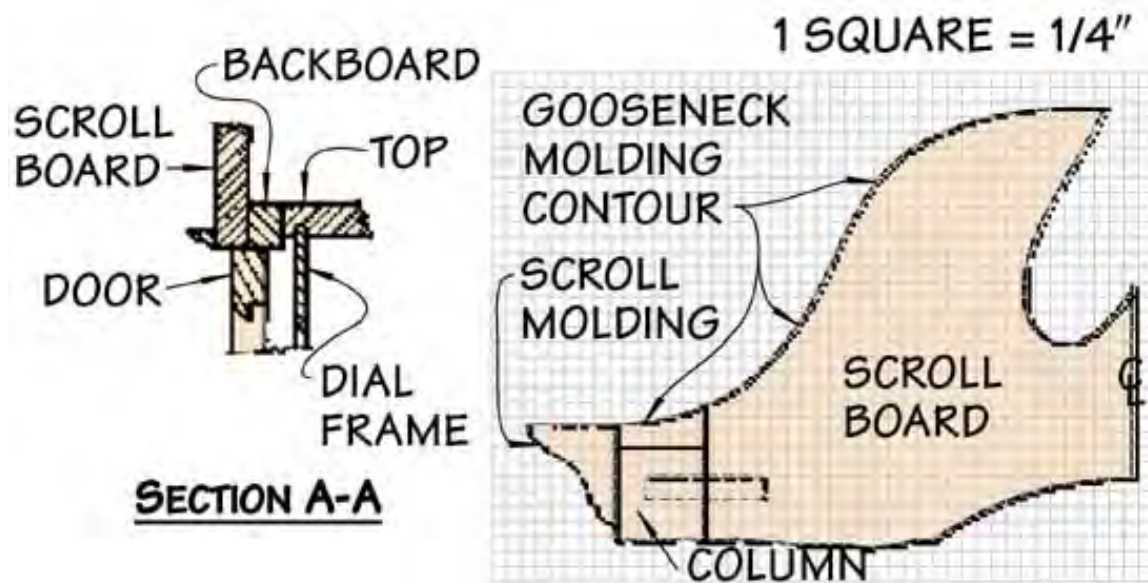

The Grandfather Clock Arch Assembly

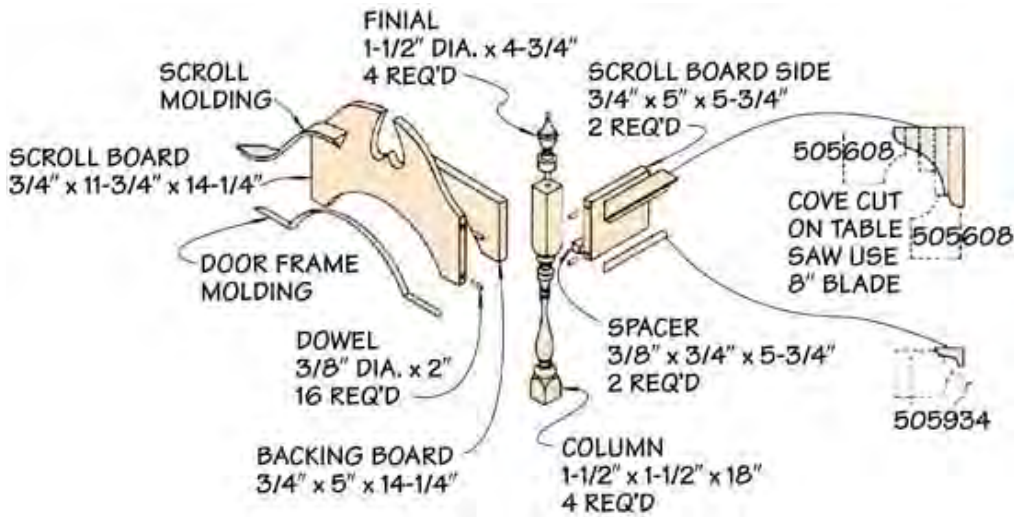

The Grandfather Clock Door Joint Layout

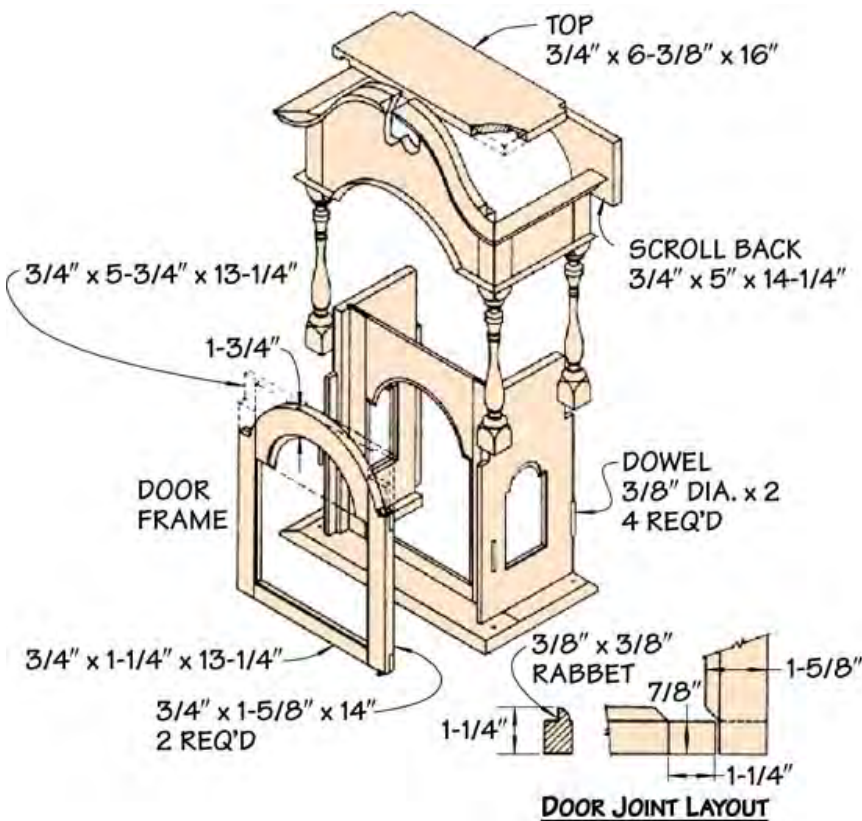



The Waist Assembly

Review and re-work the drawings for the Waist Assembly. The way the Hood turns out may change a few of the dimensions on this part.

This section is basically going to be a long box with a door and molding on the top and bottom. Sort of like a "curio cabinet", sitting between the Hood and the Base Assemblies.

First task: Choose some of the best, most attractive wild cherry stock for the sides of the Waist. Don't want to do any gluing-up on these pieces.

The major challenge of the Waist is going to be the upper and lower moldings. These pieces form important transition points in the flow of the clock's overall lines. They're not there just to "fancy it up". Try to balance the design of this one-piece upper Waist molding with the Hood moldings. You are not looking for a mirror image — just a complimentary balance.

No problem drawing this out on paper. Now, all you have to do is get the wood to look like the drawings! Shouldn't be too difficult. First, all of the moldings must look balanced: starting with a bead on the lower Hood molding and ending with another bead on the lower Waist molding. In-between, the coves will form an attractive, sweeping transition. Each cove must start at a certain point and end at a certain point...it'll take some pretty precise table saw coving on each of them. Once you've figured out the technique for the upper molding, the lower molding should be a breeze.

Chose the stock to use for the molding blanks. No burls or other figuring on them. As straight-grained as possible. Size these down...then make some test blanks of poplar...the exact same size. Practice the table saw cove cuts on these first. After that, run them over the molder.

For safety, position the fence so that the blade pulls the stock into the fence rather than away from it. Add a safety guide block on the saw table. It's job is to keep the blank from slipping away from the fence and down into the blade (see Figure 3). Use push blocks throughout the whole cutting operation. Be extra careful because you have to remove the upper saw guard for this operation.



Cove cutting on the table saw. Note use of fence and guide block to keep stock positioned correctly. Use push block for added safety.

Figure 3

Finish the upper molding. Carefully sand to remove the saw and molder knife cut marks. Don't lose the hard edges of the transition points at the beginning and end of the cove — these steps help define the lines of the clock. Use a wood cylinder padded with tissue paper under coarse Garnet sandpaper. No sense getting them sanded extremely smooth — before you get to the final sanding of the whole clock, the wood grain on all the separate pieces will have to be raised again due to temperature and humidity changes.

Cut the miters and made sure they all look good. Do not glue them up, yet. The overall dimensions of the carcass they fit onto won't be known until you actually do the final sanding.

The lower molding is a three-piece affair. If it were only one piece, the upper bead would get in the way of making the cove. The contours of this lower molding will hide the glue joints. When you get around to gluing-up the miters on the moldings, you will discover you don't need to clamp them. Just hold them by hand for about a minute to make sure the aliphatic resin glue made a good bond between the two pieces of wood. Then, simply set them aside to let them dry completely. There is plenty of "set" between the pieces to keep the joint tight.

Next, make the upper and lower rails for the Waist. Since the construction of the doors for the Waist and the Base will be about the same, hold off on making the Waist door for right now and make them both together when you make the door for the Base.

The Grandfather Clock Waist Assembly

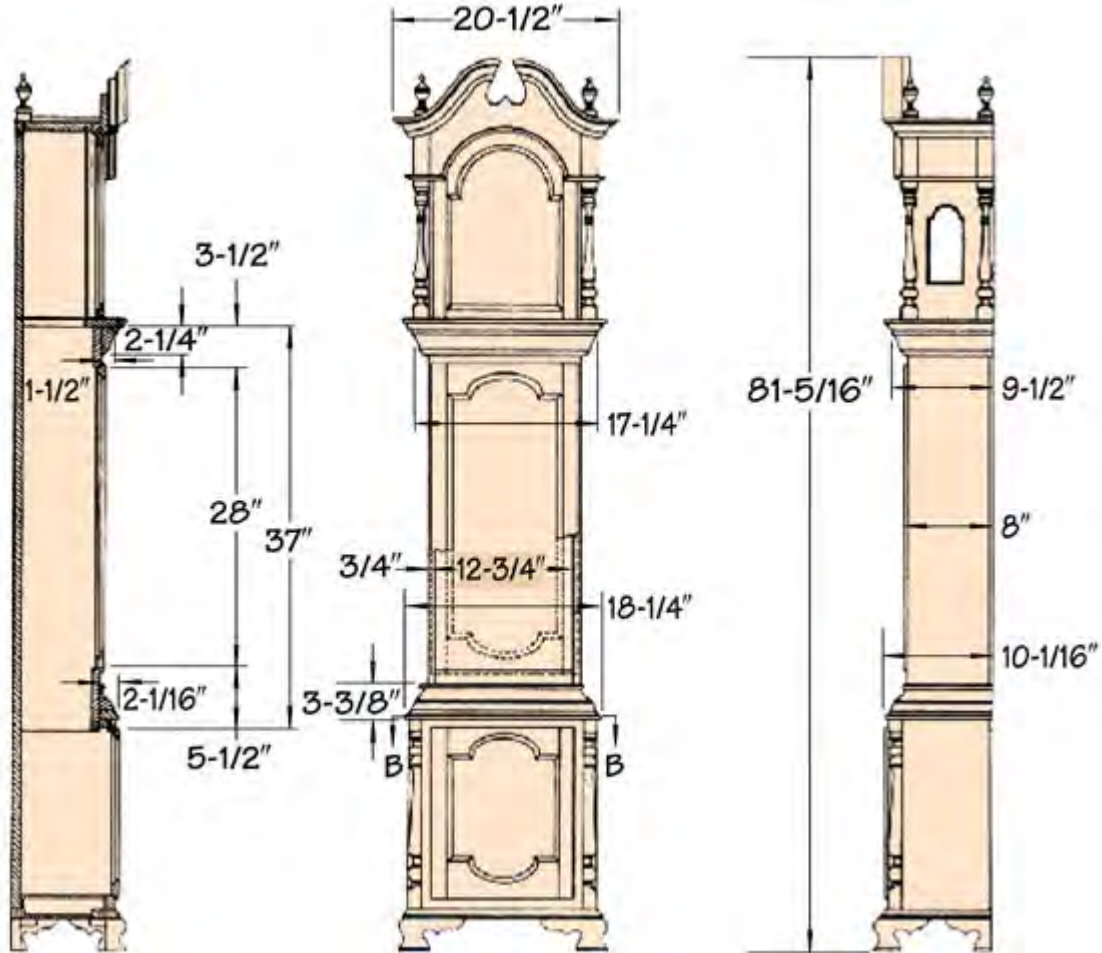

The Grandfather Clock Corner Detail

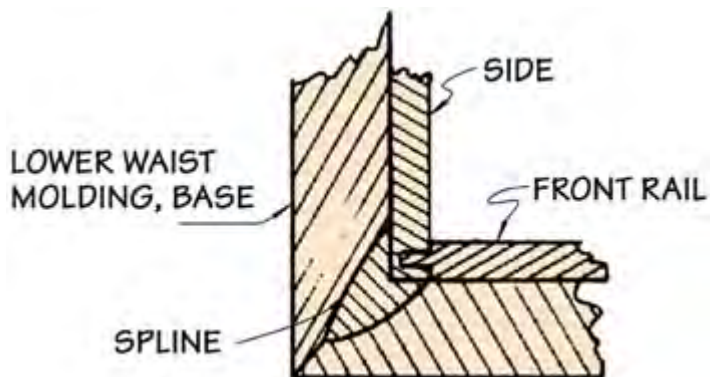

The Grandfather Clock Molding Detail

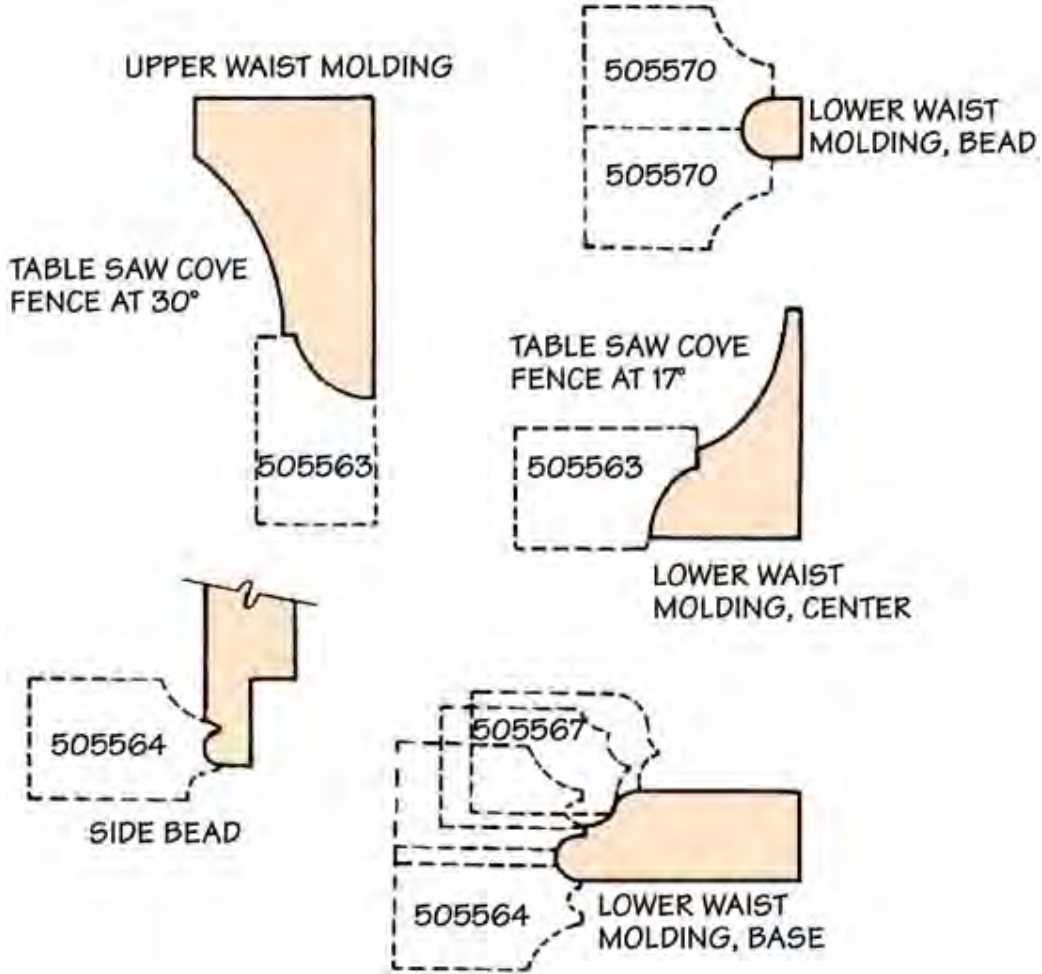

The Grandfather Clock Waist Assembly

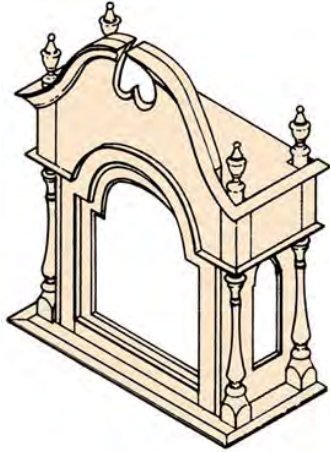

The Grandfather Clock Waist Assembly

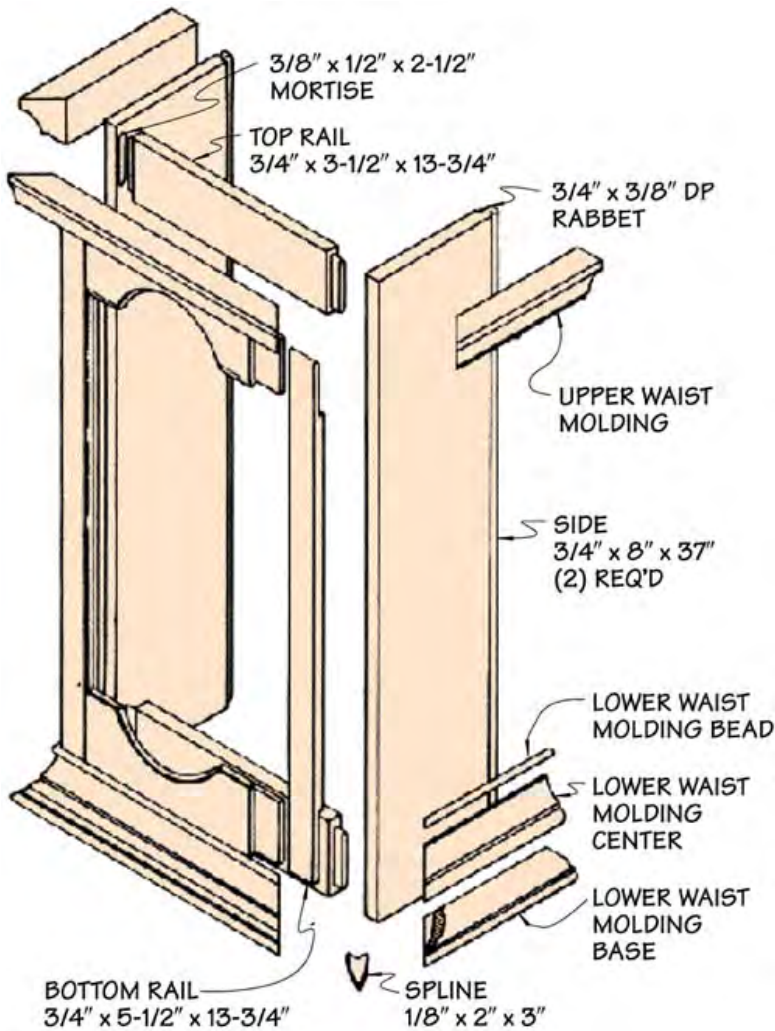



Base Assembly

You want the Base to reflect the same kind of caring craftsmanship. So, take your time, make small adjustments, plan how you would let this Base Assembly balance out the tall case."

Start by selecting clear, clean wood for the sides of the Base carcass, get the width from the lower base molding, less the split column. Looking ahead to the panel fit in the Base door, set aside some "interesting" wood -- a piece you can resaw down to expose a beautiful book-matched grain pattern, and some sap pockets. This should add a lot of "character" to the panel.

The front of the frame for the Base carcass is mortised & tenoned together. you can do it with dowels, but you want to use a more classic technique. Beneath the lower rail is what looks like a piece of Ogee molding. In reality, it's a frame that supports the whole clock, distributing its weight evenly onto the feet, underneath.

This allows you to make a hidden compartment by installing a false bottom in the base. Make this molded frame with a blind spline (see Figure 1) to reinforce the corners. Put it all together and glue it up, then mold the edge.

From Hood to Base, the doors on the Clock use the same, simple lap joints at the corners. Use miters to join the thumbnail molding at the corners. The vertical line of the doors continues from the top to the bottom of the clock, so the overall length of the door rails is set for you by the width of the Hood door.

For the Waist and Base doors, the bottom rail is wider than the top rail, lending a balanced look to the door. The Base door stiles are 1/4-inch wider than the Waist door stiles. This adds a little "bulk" to the base. The width of the vertical front frame stiles will be dictated by the size of the split turnings you use for decorating the Base . . . and by the width of the door opening. That's why you need to design these turnings before you get very far into building the Base. You want them to look something like the columns on the Hood -- not exact duplicates, though. That will make them too "busy".

When you get around to doing the doors, do a mini-production run on them. It saves set-up time. Cut the elliptical contours of the top and bottom rails, then drum-sand the sawn edges first. Next, cut the thumbnail on the inside edge of the door frame. Use the Shaper because of the curved half-ellipse (see Figure 4).

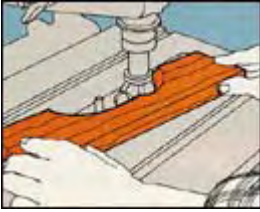

Forming the thumbnail molding on a door rail. Elliptical shape requires use of the Shaper with starter pin and rub collars for this operation.

Figure 4

The bracket feet look pretty fancy -- and take some time -- but really isn't difficult to make. Don't make them as four separate pieces, but as a box that's cove-cut around the perimeter. After this, the box is cut apart and the Bandsaw is used to do the scroll work. The left, front and right sides of the box are made of 1-3/4-inch thick stock . . . the back of 3/4-inch stock. The two front corners are spline-mitered (see Figure 3), but once they're coved and contoured, they look like there's no joint at all.

Use a wooden template to maintain the pattern on the matching feet. The tight curves cause you to have to use relief cuts on the Bandsaw to ease them to completion. Use a rabbeting plane to help smooth the outside curves on the feet. Some Drum Sanders are small enough to fit a number of the tight curves of the bracket design, but few are long enough for the really thick stock. So, use small files and sandpaper wrapped around small dowel rods for these.

You want two quarter columns to ease the front corners of the Base. These split turnings are made from a single 2-3/4-inch turning blank. Glue it up so the glue line wouldn't show once the piece was cut apart on the Bandsaw. Use woodworker's glue and allowed plenty of time for setup/drying. While it is drying, practice turning previously drawn design on a piece of 4 X 4 pine.

The oversized blank leaves you enough margin to split the single turning on the Bandsaw, then remove the saw marks by using the Jointer. Use the Jointer as well to backcut the quarter-columns so that you get good contact all along the front edges.

These split turnings were the last cuts for the clock construction -- except for the back piece.

Last of the construction . . . the back. It's to be 3/4-inch veneered plywood. It'll not only support the entire weight of the clockworks, but also act as a sounding board for the chimes that will be attached to it.

Finally, put the entire case together -- from top to bottom -- to check for final fit. And though it seems like you are almost done with the clock, the final sanding and finishing is yet to come.



Sanding the moldings is a real challenge. Take careful care to keep the corners sharp and clean, with well-defined lines. Start sanding with 80-grit Garnet paper, then move on to 100-grit . . . ending up with 150-grit.

Work in stages, sanding and finishing the Hood first, then the Waist and Base. When you get to the final sanding, apply a coat of oil finish, then work it in with 220-grit, silicon carbide, wet/dry sandpaper. As you rub out the finish, the oil and sawdust mixed to make a paste that fills the wood grain nicely.

Finish the inside of the Clock as well as the outside. Use the same number of coats of finish to help prevent warpage that can result from finishing only one side. Finish up with a high quality paste wax for a really hard finish. Rub the wax in with #0000 steel wool, then buff it out with a soft cloth. Three coats will do the trick.

The Grandfather Clock Base Assembly

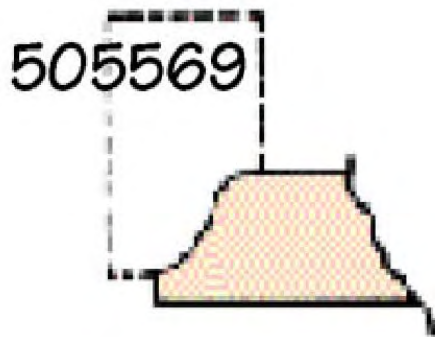
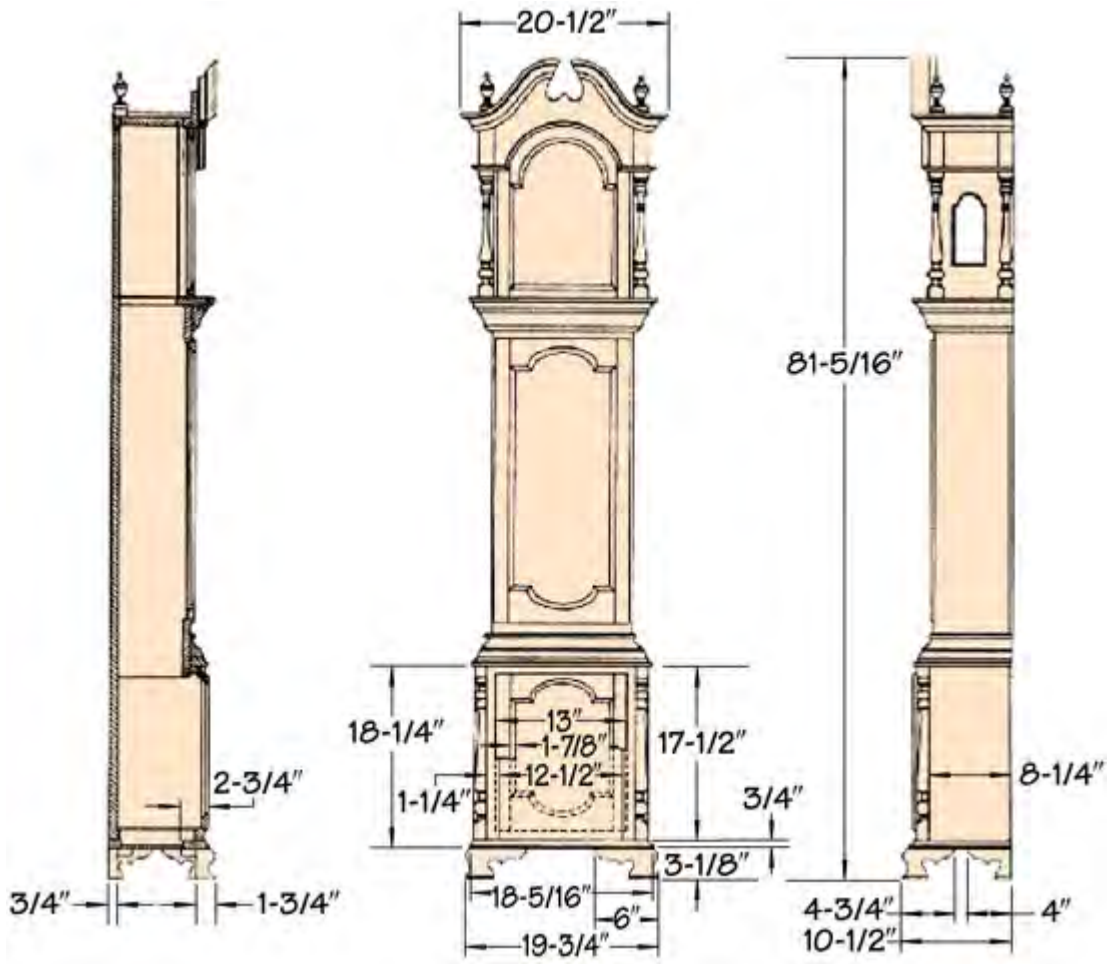

BASE MOLDING

The Grandfather Clock Base Assembly

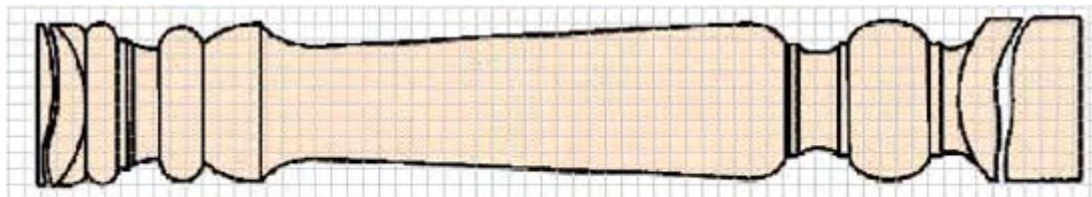
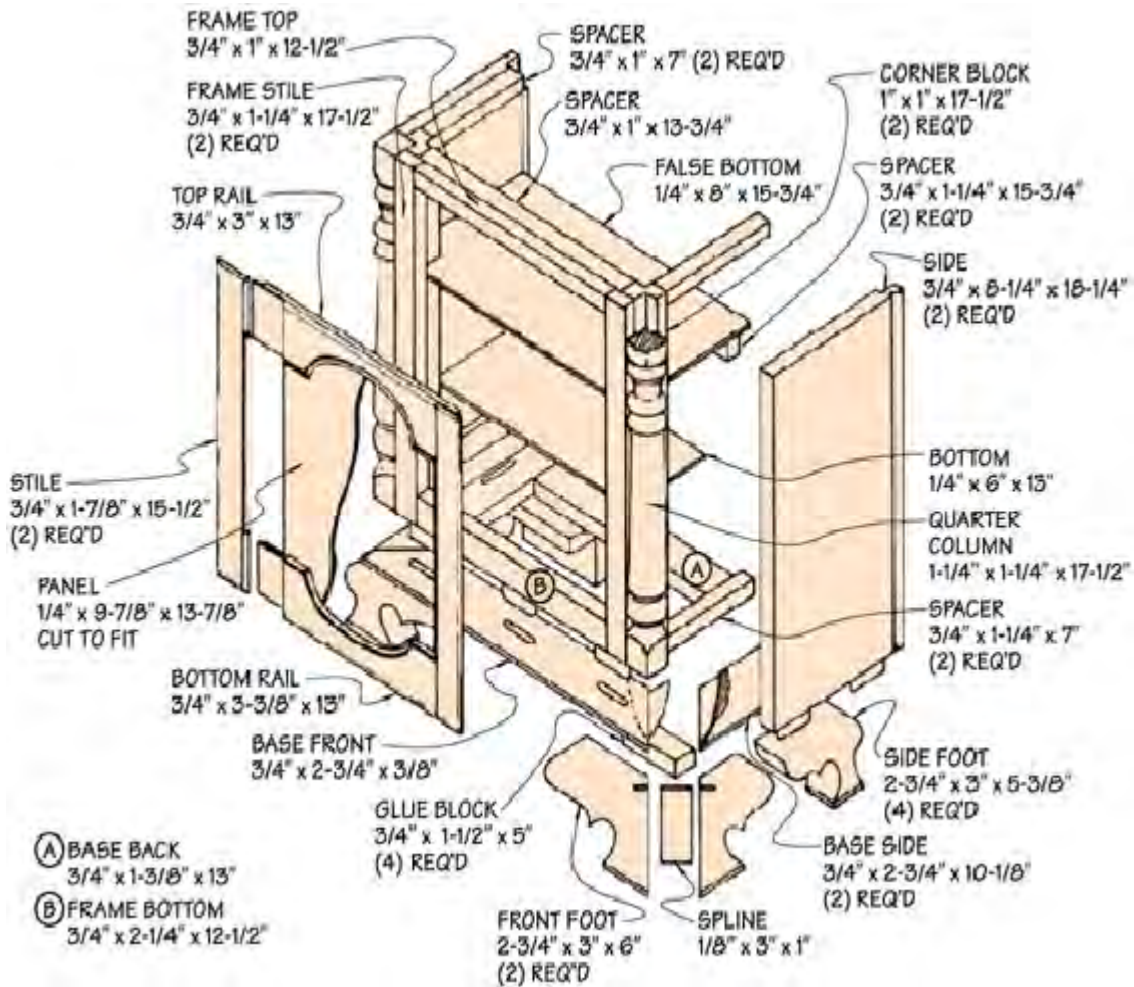

QUARTER COLUMN PROFILE – 1 SQUARE = 1/4"

The Grandfather Clock Base Assembly

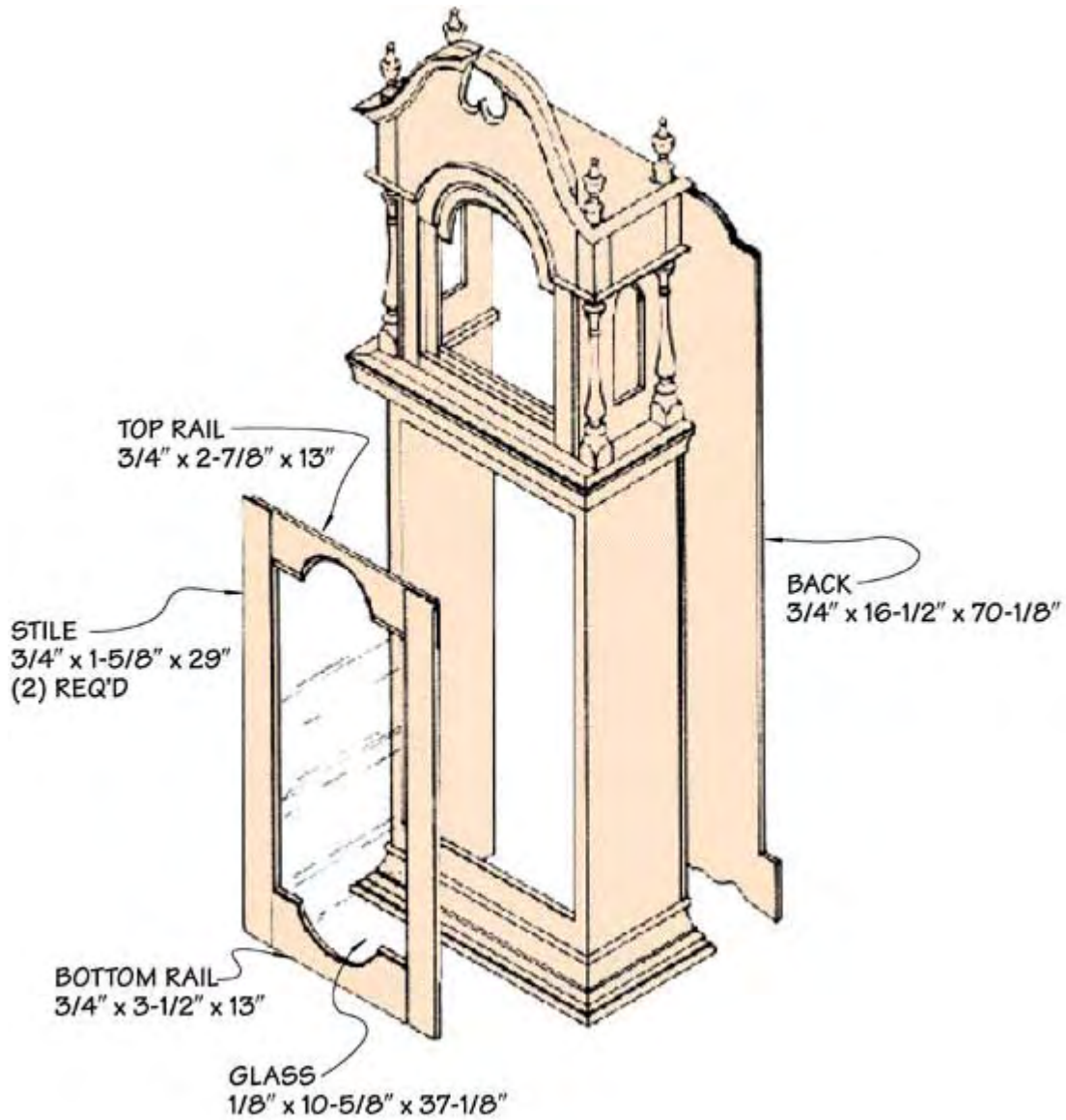

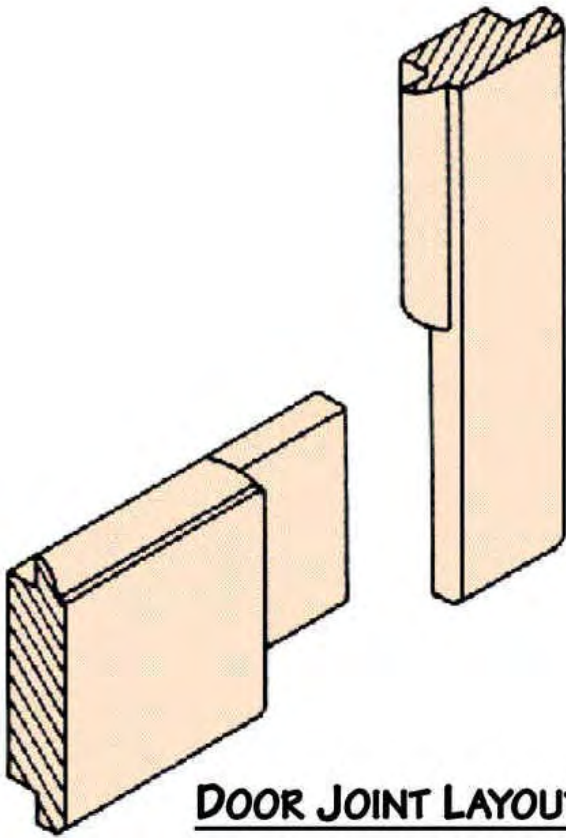

DOOR JOINT LAYOUT

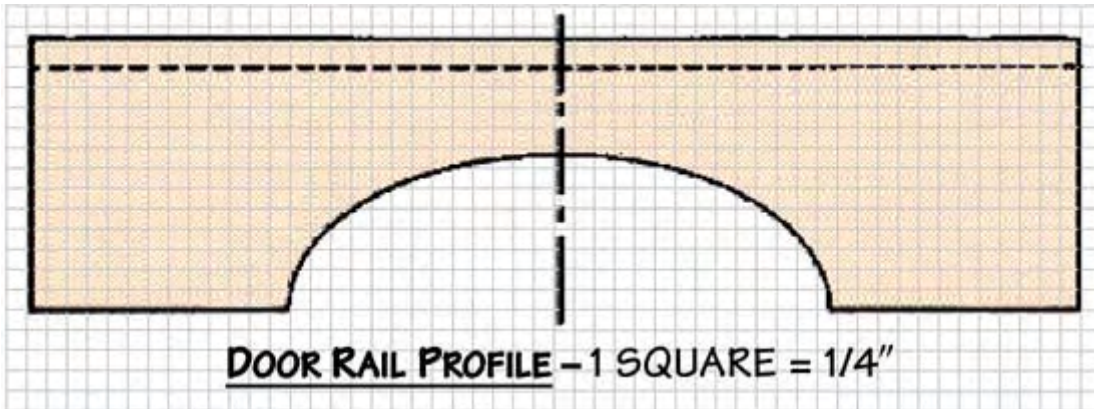

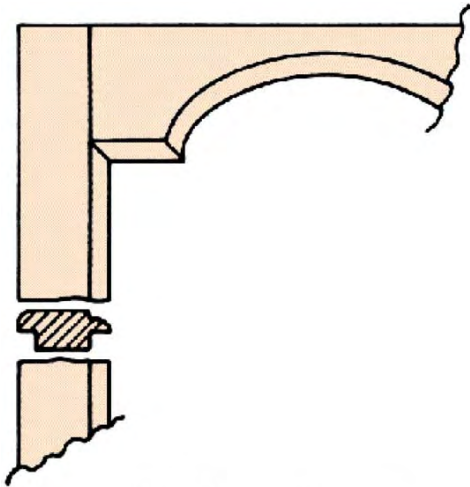

DOOR STILE PROFILE

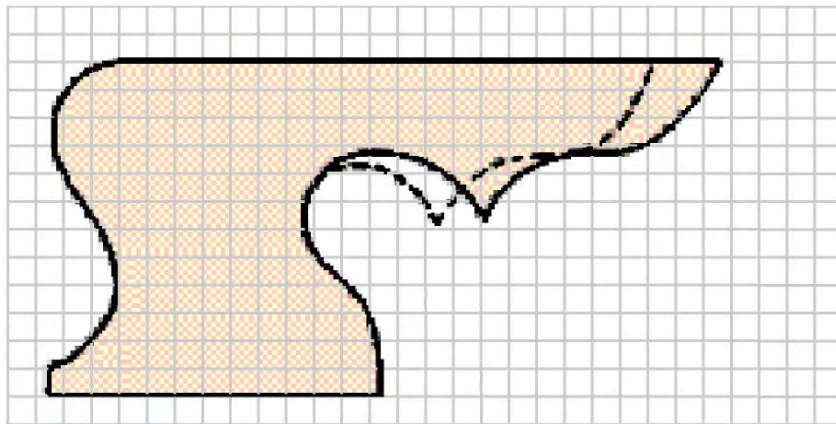

FOOT PROFILE - 1 SQUARE = 1/4"

“Get A Ball” Out of Your Woodworking

A Great “Build-It-In-A-Weekend” Gift or Desktop Accent Piece



One of the greatest things about having a woodworking shop is this: When you get an idea for a project (no matter how “goofy” it may seem), you can go into the shop and “have at it”! And the best part of all is that a woodworking shop is not only a great place to build a project . . . it’s a fantastic place for stimulating ideas, as well! Don’t you just love woodworking?

MARK V owner Troy Todd found this situation to be true for him, as well, when he created this unique, whimsical **Wooden Gumball Machine**.

Here’s how to make one (refer to the [assembly drawing](#) for all part references):

1. Cut out the stock. Follow the list of materials at the end of the article. For best results, we suggest you use a hardwood such as cherry or maple. Cut the round discs (A thru E) using your bandsaw or scroll saw and mark the center of each piece clearly.

2. Drill a 1/4-inch hole in the centers of parts A through E. Mark the part letters on pieces B through E. Now, make the simple [clamping jig](#) shown in Figure 1 from a 3/4-inch x 8-inch piece of stock and a 1/4-inch-20 x 3-inch pivot bolt.

Next, stack discs B, C and D over the pivot bolt on the jig with disc B on the bottom. Lay the jig flat on the surface of your MARK V Drill Press Table, with the stacked discs clamped in position with 1/4-inch-20 nut and washer so they won’t rotate.

Locate a point 3/4-inch in from the center of your discs and drill a 5/8-inch diameter hole. Set your drill press stop to drill all the way through discs D and C . . . but only half-way through disc B. Drill your 5/8-inch hole.

3. Rout the slide lever slot on disc C by first marking off the 2-3/4-inch arc on the edge of the disc. Tilt your MARK V’s table 90-degrees so its surface is parallel with the machine’s way tubes, then clamp the jig to the table surface as shown in Figure 1 . . . so the point of your drill bit is in exact left-right alignment with the centerline of your pivot bolt.

Mount disc C over the pivot bolt and drill a 1/4-inch diameter by 1-inch deep hole at each end of your drawn arc. Next, use your MARK V’s Router Attachment with a 1/4-inch Bit to rout a 1-inch deep groove, connecting the two 1/4-inch holes you just drilled.

Caution: Do this in shallow, 1/8-inch deep passes to ensure the smoothest slot.



4. Cut out the center of disc C with a 2-1/2-inch hole saw or scroll saw. While you're at it, also cut out the center of the body piece (E) and set piece E aside.

Now, take the center (scrap) stock you just cut out of disc C and clamp it down over the jig pivot bolt. Drill a 1/4-inch diameter x 3/4-inch deep hole at the centerline for the slide lever, next to the 5/8-inch vertical hole as shown in Figure 2.

5. Chamfer the 5/8-inch diameter holes on discs C & D. Use your Drill Press with a 1-inch countersink bit. Also locate and create a countersink "dimple" on piece A to catch the gum ball as it exits the hole in the side of disc B.

6. Drill a 5/8-inch diameter hole for the gum return on disc B. Use your MARK V in Horizontal Boring mode, with the jig clamped to the table surface as shown in Figure 3. Tilt the table 5-degrees so your bit exits through the surface of the disc as it approaches the center.

7. Assemble the machine by first gluing and clamping disc B to disc A with the center pin (F) glued into place. Line up the gum return on disc B with the countersunk gumball catch "dimple" you created in disc A in [Step #5](#) on the previous page.

Next, you'll need to carefully locate disc C before gluing. First, drop the scrap piece out of the center of disc C over the center pin (F). Next, drop the outer ring of disc C (with the edge groove) into place. Align the 5/8-inch holes in discs B & C and insert the slide lever (G) into the 1/4" hole in the edge of disc C (see Figure 4).

Adjust the outside (C) ring so the lever is at the left-hand end of the slot. Use a pencil to mark the outside of the ring and the glued-up assembly. Now, hold the ring in place with your hand while you check the side-to-side movement of the lever. Remove the slide lever (G) and glue the outer ring into place, being careful not to get any glue on the inside (C) disc.

Once the glue has set up, move the slide lever all the way to the right of the slot. Locate the position of disc D by aligning the 5/8-inch holes. Now, glue disc D into place . . . then attach disc E with glue. Clamp the entire base assembly, and allow the glue to set up for 24 hours.

8. Turn the base assembly by mounting it to your 3-3/4-inch diameter Lathe Faceplate. Turn the top (E) first, creating a recess that's the same diameter and approximate depth as the lid of a small mouth canning (Mason) jar. Begin by using a parting tool to establish your dimensions, then a roundnose chisel to complete all the contours. Sand the entire piece while it's still mounted on the Lathe.

9. Finishing touches. Make the slide lever knob (H) by first drilling a 1/4-inch diameter by 1/2-inch deep hole in one end. Hold the knob with pliers as you drill it. Glue the lever

into the knob and allow it to dry. Next, mount the slide lever assembly (pieces G & H) in your Drill Chuck and “turn” the piece using files or sandpaper. Glue the lever assembly into place.

10. Apply salad bowl finish or paste wax, fill with gumballs and enjoy!

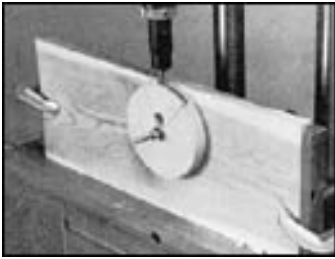

Figure 1

Routing the slot for the lever with the Shopsmith Router attachment and a [special clamping jig](#).

Figure 2

Clamp the center disc (scrap from Ring C) to the jig and drill the slide lever hole.



Figure 3

Tilt the table 5-degrees and drill the gum return with the Horizontal Boring Machine.

Figure 4

Aligning the parts for gluing.



1/4" x 3" STOVE BOLT
(NUT AND WASHER
NOT SHOWN)

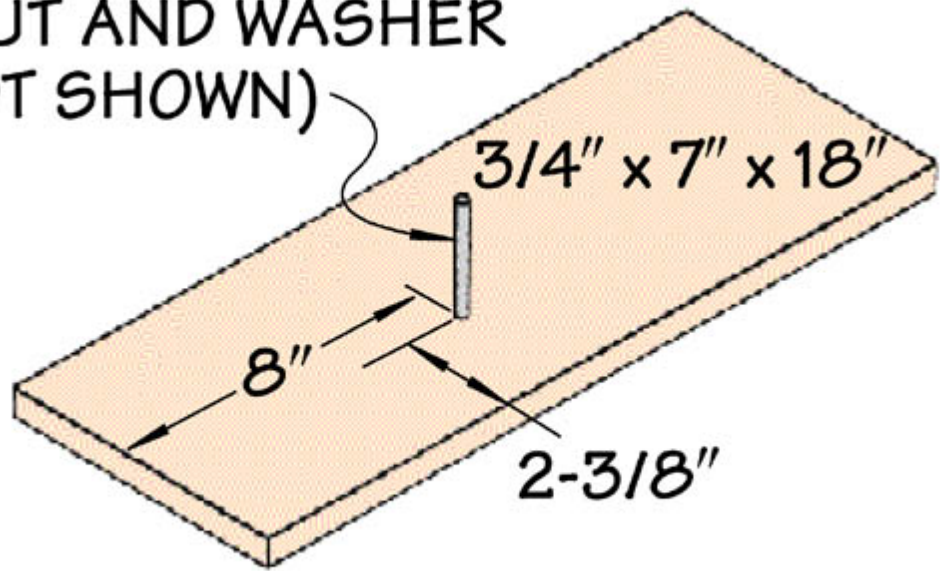

CLAMPING JIG

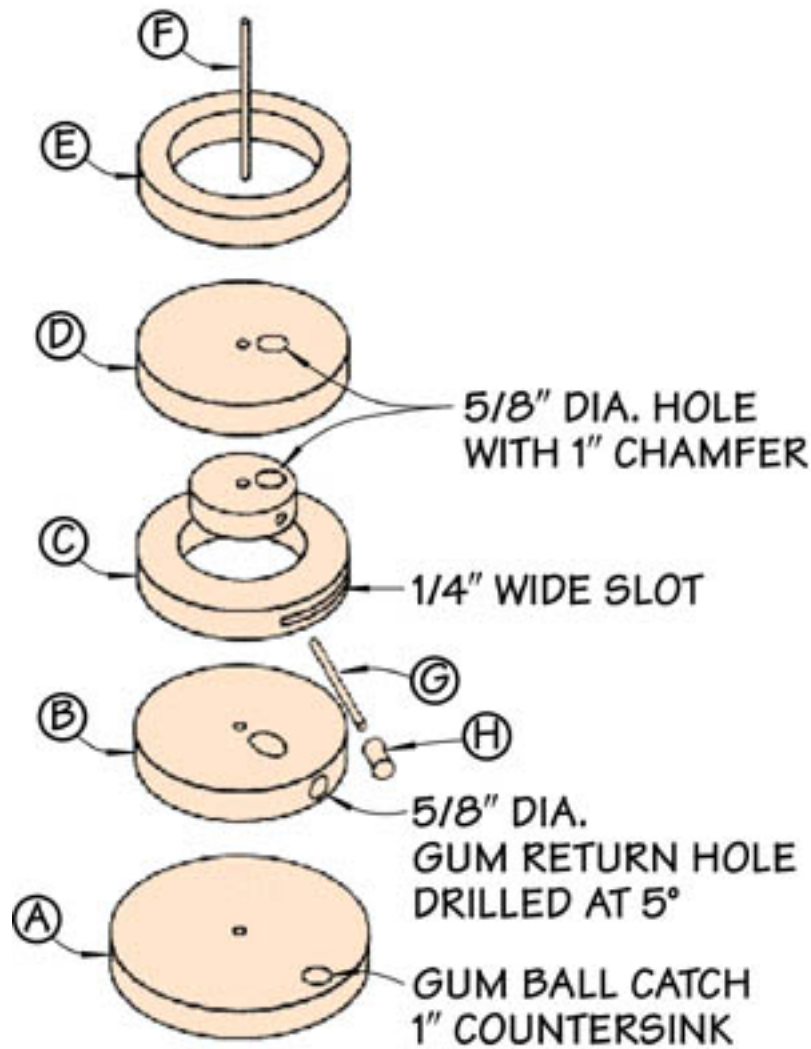

List of Materials

(finished dimensions in inches)

- A Base Disc 6-1/4 dia. x 3/4
- B Body Disc 4-3/4 dia. x 3/4
- C Body Ring 4-3/4 dia. x 3/4
- D Body Disc 4-3/4 dia. x 3/4
- E Top Ring 4-3/4 dia. x 3/4
- F Center Pin 1/4 dia. x 4 dowel pin
- G Slide Lever Pin . . 1/4 dia. x 2-1/2 dowel pin
- H Slide Lever Knob . . 3/4 dia x 3/4 dowel pin

GUM BALL MACHINE ASSEMBLY



Step 3: Cut out your workpieces, making them 10-1/2-inch by 4-1/2-inch by the thickness of your choice. Align a stack of workpieces and attach them temporarily together using double-stick carpet tape (available at any hardware store or home center). Be sure to keep the height of your glued-up stack within the throat depth limitations of your Scroll Saw or Bandsaw.

Step 4: Trace your patterns onto the top workpiece in your stack

Step 5: Cut out your four stacks of puppet parts (two feet a body and a head). Take your time. Forcing the saw to cut faster than it wants will adversely affect the quality of the parts you get, creating a lot more sanding work for you.

Step 6: Drill the yarn/control string holes, using a 1/4-inch diameter bit for the clothesline that attaches the head and feet to the body (5 holes) — and a 1/16-inch diameter bit for connecting the two ends of one control stick to the head and the body with monofilament.

Step 7: Smooth all edges, using sandpaper. Don't try to do this with your router. The pieces are too small to be held safely.

Step 8: Apply a non-toxic finish, such as a salad bowl finish or non-toxic paints.

Step 9: Assemble the puppet, by gluing the ends of ordinary 1/4-inch diameter clothesline into the two feet (pass one end through the lower body hole, first, of course) and the two holes you drilled in the edges of the head and body. DO NOT glue the clothesline to the body, at the point where it passes through.

Step 10: Attach the control lines to small 1/16-inch diameter holes drilled in the ends of two 8-inch long x 3/4-inch wide x 1/4-inch to 3/8-inch thick control handles. Drill a 1/16-inch diameter hole near the far ends of the two handles. Next, cut four pieces of 36-inch long monofilament fishing line. Attach one end of each line to the control handle ends by tying them through or gluing them to the 1/16-inch holes. Attach the opposite ends of the lines on the left/right control handle to the feet by tying them snugly to the clothesline ends where they glue into the feet. Attach the remaining two lines to the small, 1/16-inch diameter holes in the body and the head.

Step 11: Assemble the control handle by connecting the two control handles to each other in the middle with a screw or bolt. Some people claim to achieve better puppet control when the connection between the two handles is left a little loose.

Step 12: Enjoy!

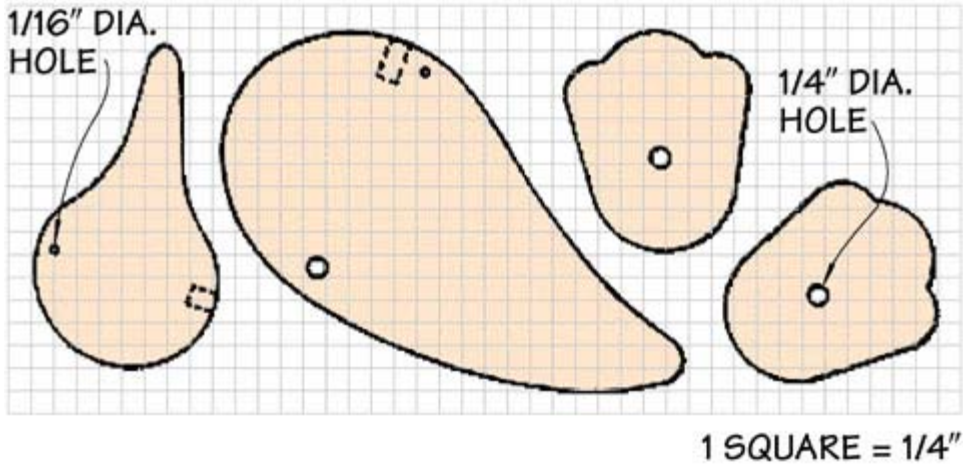

TOY CRANE

Here's an easy-to-make working crane that's destined to get plenty of hours of play time



Making a toy that operates with cranks, wheels, pivots and strings gives a woodworker the feeling that he can compete successfully with the big-time toy-makers. This is especially evident when the child a toy is intended for gets hour-after-hour of good playtime out of it.

This crane is a great project that's certain to provide lots of fun...not only for the child who plays with it...but for the woodworker who builds it, as well.

When completed, the cab will rotate a full 360-degrees -- the boom will raise and lower -- and the hook will go up and down. Added to these features is a simple "push/pull" locking mechanism on the boom and hook cranks. And although this may look like a complicated toy to build, it's really quite easy.

I used clear pine stock, hardwood dowels and yellow woodworker's glue for the basic construction. All the wheels were made with hole saws and arranged on the crane to give the illusion of being a tracked (bulldozer or tank-like) vehicle.

STEP 1:

Cut all the parts to size according to the list of materials — except for the cab sides (F), which will be cut out in Step 3, below. Use a 1-3/8-inch hole saw to cut out the large, 1-1/4-inch wheels (B); a 1-1/8-inch hole saw to cut out the smaller 1-inch wheels (C) plus an extra for the cab pivot pin lock (T); and a 1-5/8-inch hole saw to cut out the 1-1/2-inch crank wheels (P).

NOTE: If you can't locate these exact size hole saws, you can use a larger diameter saw to cut them out, then mount them on your drill press and file or sand them down to the smaller sizes you need. The 7/8-inch diameter



cab pivot pin lock (T) is made by sanding or filing-down an extra disc that's been cut out with your 1-1/8-inch diameter hole saw.

STEP 2:

Make the chassis (A) by first laying out and drilling the 5/16-inch diameter axle holes. Then, use a bandsaw to cut the 30-degree bevels on the ends. Drill the 1-inch diameter by 1-inch deep hole for the cab pivot pin lock (T).

STEP 3:

Make the cab by first drawing all the contours and locating the holes for the cab sides (F) on a piece of 3/4-inch stock. Drill the 3/8-inch holes for the wheel axles (Q). Cut out the side design on the bandsaw or scroll saw. Resaw this piece on the bandsaw to get the two (approximate) 3/8-inch thick cab sides. Don't drill the 1/4-inch diameter crank lock holes yet. We'll do this later.

Next, drill the 3/8-inch diameter by 1/2-inch deep hole in the bottom of the cab floor (G) for the cab pivot pin (S). Screw two small screw-eyes into the cab rear panel (H). Glue the cab sides (F), cab floor (G), and cab rear panel (H) together. When gluing the sides in place, temporarily slip (do not glue) one or two 3/8-inch dowels through the crank axle holes for alignment. Do not glue the roof on at this time.

STEP 4:

Make the cab roof (J) and counterweight (U). Round the top and side edges of the roof on your belt or disc sander. Then, drill the 1/2-inch hole for the exhaust stack (V). Glue the stack into position and install the 1/4-inch screw-eye. Set the roof aside.

Round the rear outside edges of the counterweight (U) and glue and clamp it to the cab assembly.

STEP 5:

Make the crank assemblies. Using a 3/8-inch diameter drill bit, enlarge the 1/4-inch diameter holes in the crank wheels (P) that were left by your hole saw's pilot drill. Drill the offset 1/4-inch diameter holes in each crank wheel for the crank wheel handles. Slide each of these crank wheels onto the 3/8-inch diameter crank axles (but don't glue them yet).

With a 1/4-inch drill bit mounted in a portable electric drill, insert the bit through the crank wheel handle hole you just drilled and use it as a guide to

THE DANCING DUCK



Few will argue that puppets have been favorite toys of children for a long time. Perhaps that's because they can be easily made to look and act just as silly as we all often feel. Kids can entertain themselves for hours on end with these stimulating toys . . . and when they're demonstrated with enthusiasm at craft fairs and flea markets, few toys will outsell them!

Using a technique called "Pad-Sawing" (cutting out a stack of identical parts at the same time), your Shoppersmith Scroll Saw or Bandsaw will make easy work of spitting out Dancin' Ducks-- that quickly turn into dollar bills.

Here's how to do it, using about 10-1/2-inch of 4-1/2-inch wide by 3/8-inch, 1/2-inch or 3/4-inch thick stock for each puppet. .We like the 3/4-inch thick model, but you can make it out of virtually any thickness of lumber you like. .Of course, the thinner the puppets, the more you'll be able to cut out at once . . . although the added weight of the thicker 3/4-inch puppets seems to make them work a little better.

Step 1: Transfer the pattern from the drawing onto sheets of 1/4-inch grid paper, glued to a piece of 1/8-inch hardboard or heavyweight (non-corrugated) cardboard.

Step 2: Cut out the templates using your scrollsaw or bandsaw.



drill a series of four half-deep holes at approximate 90-degree intervals in the rotation of each crank handle. During assembly, be sure to put the cranks on the right side for right-handers...or the left side for left-handers. Drill the 1/8-inch diameter string holes in the crank axles (Q) (see figure 1). Sand the axles so they move freely where they pass through the cab mounting holes. Don't sand the very ends of the axles where they go into the crank wheels. You'll need a tight fit, here.

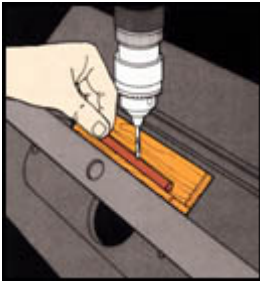

Use wood backup when drilling the 1/8-inch holes in the crank axles.

Assemble and mount the crank wheels (P) , crank handles (R) and crank axles (Q) with glue so each end of each axle is flush with the outer surface of a crank wheel. When assembled, there must be enough "play" to allow the assemblies to move side-to-side so the boom and hook positions can be locked and unlocked by engaging the protruding ends of the crank handles (R) in the holes you drilled in the cab side. Remember that the crank/axle with a single string hole goes in the top forward position on the cab.

IMPORTANT: When gluing crank handles (R) into crank wheels (P) , be sure the handles each protrude about 3/16-inch beyond the back side of their crank wheels. These protruding handle pins are engaged in the half-deep 1/4-inch holes you drilled in the cab side, acting as stops to hold the boom and hook in position during play

STEP 6:

Make the cab pivot lock assembly by drilling a 3/8-inch diameter hole in the cab pivot pin lock (T), then gluing the cab pivot pin (S) into (T).

Now, drill a 7/16-inch hole in the center of platform (E). Once the pivot lock assembly above has dried, drop the pivot pin lock (T) with pin (S) attached and protruding through platform (E) into the 1-inch x 1-inch hole you drilled in the chassis (A), in Step 2.

Spread glue on the chassis (A)...(being careful not to get any glue near the center pivot pin area)...and glue the platform (E) to the chassis (A).



STEP 7:

Make the crane boom (K) by first drilling the holes according to the drawing. There are nine 3/4-inch "lightening" holes, a 7/16-inch hole at the base for the anchor pin (N) and two 1/8-inch cable run holes. Drill the 1/8-inch holes in the hook cable guides (M). Cut out the boom using the bandsaw or scroll saw and sand smooth. Glue the hook cable guides (M) into place and set aside to dry.

Drill the 3/8-inch boom mounting holes in the boom supports (L). Line up these holes with the ones in the cab sides (M) using the crane anchor pin (N) and glue the supports into place. Keep the glue away from the holes, because once the supports have had a chance to set up, you'll have to remove the anchor pin to slip the boom into position between these two supports.

Now, mount the boom into the cab assembly by gluing the crane anchor pin (N) into place.

NOTE: Be careful not to get any glue in the center area of the anchor pin where the boom pivots on it.

Sand the axles (D) where they pass through the chassis (A) and then glue the wheels (B & C) into place.

STEP 8:

Stringing the boom. Begin by cutting a 30-inch length of twisted nylon cord and tying a knot in one end. Singe the end of the cord with the knot using a match or a lighter to prevent the knot from loosening. String the boom cable line through one of the holes in the bottom/rear crank axle. Pass this through one of the screw-eyes in the cab rear, then through the 1/8-inch hole that runs side-to-side near the tip of the boom. Now, bring this same cord back down through the other screw eye in the cab back...then into the other hole in the bottom/rear crank axle.

When the boom is in its horizontal-most position, pinch the line up against the crank axle hole. Now, raise the boom to a full vertical position and tie a knot where you're pinching it. The line should be taut when the boom is dropped back to the horizontal position. Adjust the knot if the line's too loose. Raise the boom, pull out the line and singe this end of your knot . . . just as you did the other.

STEP 9:

Stringing the hook assembly. Start by pinching one end of the small S-Hook around two 1/2-inch washers. Set this aside. Cut a 36-inch length of cord, tie a knot in one end and singe it as you did the other. Pass the line through the hole in the top/forward crank axle, then through the screw-eye in the roof (remember...the roof is still loose at this point).

Now, pass the line through the two cable guides (M) on the top surface of the boom and down through the 1/8-inch hole that runs top-to-bottom through the very tip of the boom. Tie this end of the line to the S-Hook. Hold the roof in place while you raise and lower the hook using the crank. If everything works properly, glue the roof in place.

Overall Assembly

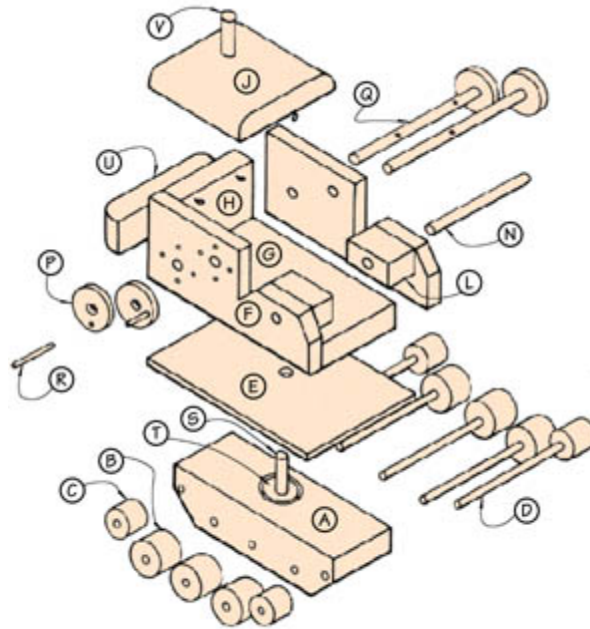

CRANE ASSEMBLY

(RECOMMENDED FOR AGES 5 AND UP)



List of Materials

(finished dimensions in inches)

- A** Chassis 1-1/2 x 2-1/4 x 6
- B** Main Wheels (6) 1-1/4 dia. x 3/4
- C** Secondary Wheels (4) 1 dia. x 3/4
- D** Wheel Axles (5) 1/4 dia. x 4-1/8
- E** Platform 1/4 x 4 x 6
- F** Cab Sides (2) 3/8 x 2-3/4 x 5-3/4
- G** Cab Floor 3/4 x 3 x 5
- H** Cab Rear Panel 3/4 x 3 x 2-3/4
- J** Cab Roof 3/4 x 3-1/4 x 3-3/4
- K** Crane Boom 3/4 x 1-1/2 x 13
- L** Crane Boom Supports (2) 3/4 x 1-1/2 x 1-1/8
- M** Crane Hook Cable Guides 1/4 x 3/4 x 1
- N** Crane Anchoring Pin 3/8 dia. x 3-3/4
- P** Crank Wheels (4) 1-1/2 dia. x 3/8
- Q** Crank Axles (2) 3/8 dia. x 4-7/8
- R** Crank Handles (2) 1/4 dia. x 1-1/2
- S** Cab Pivot Pin 3/8 dia. x 1-1/2
- T** Cab Pivot Pin Lock 7/8 dia. x 3/4
- U** Counterweight 3/4 x 1 x 3-3/4
- V** Exhaust Stack 1/2 dia. x 2

Miscellaneous

- 1/4" Screw Eyes (3)
- 1/2" Flat washers (2)
- S-Hook
- #18 Twisted Nylon Cord

Chassis Layout

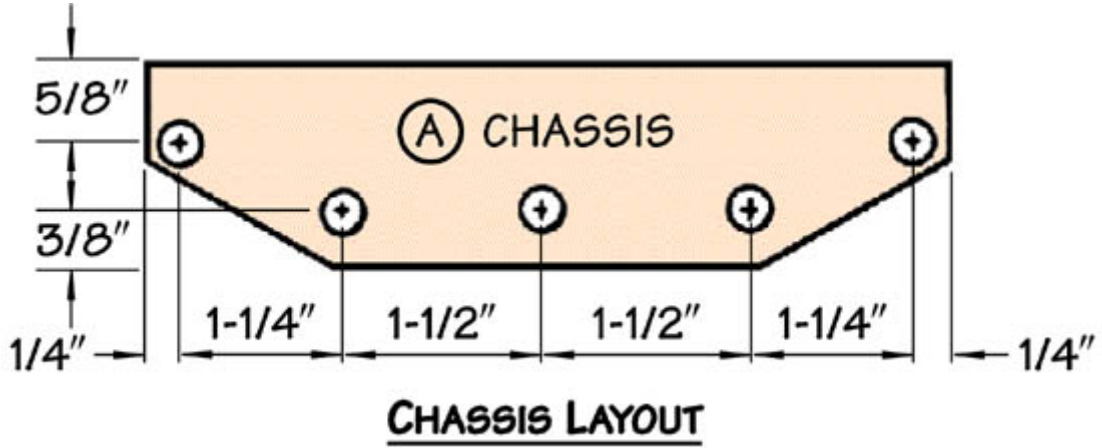

Side Layout

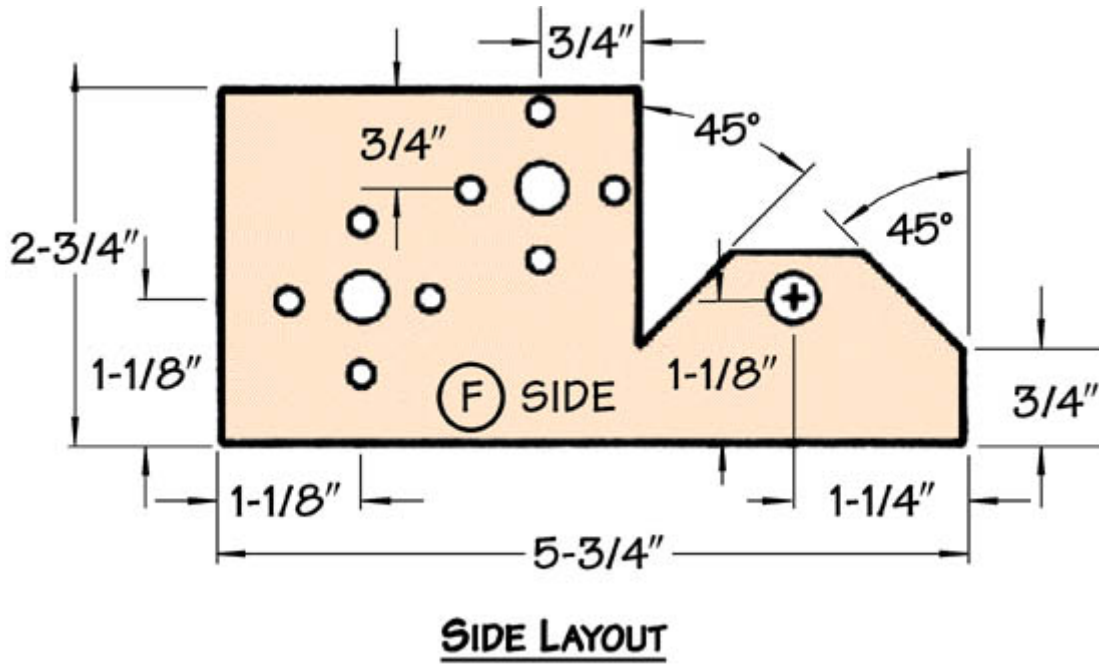

Boom Layout

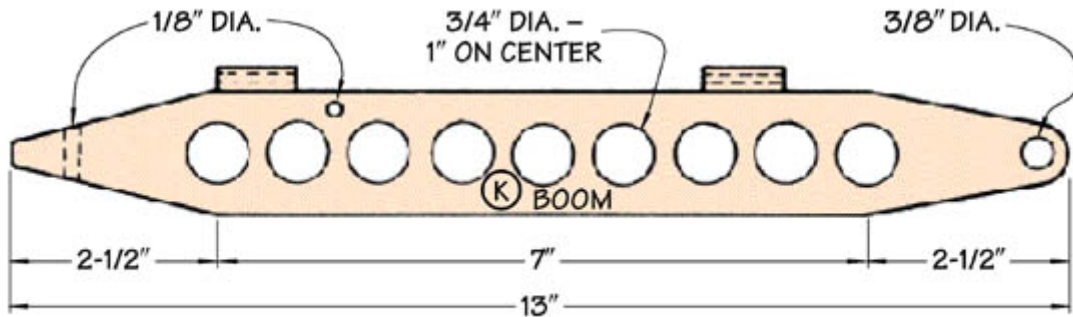

BOOM LAYOUT

Overall Dimensions

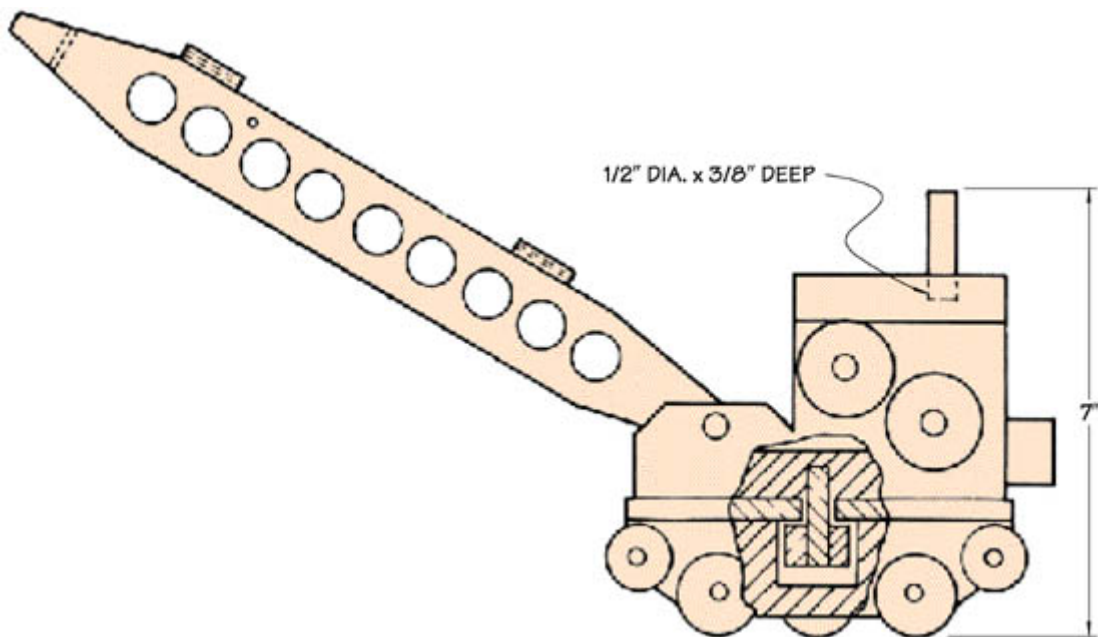

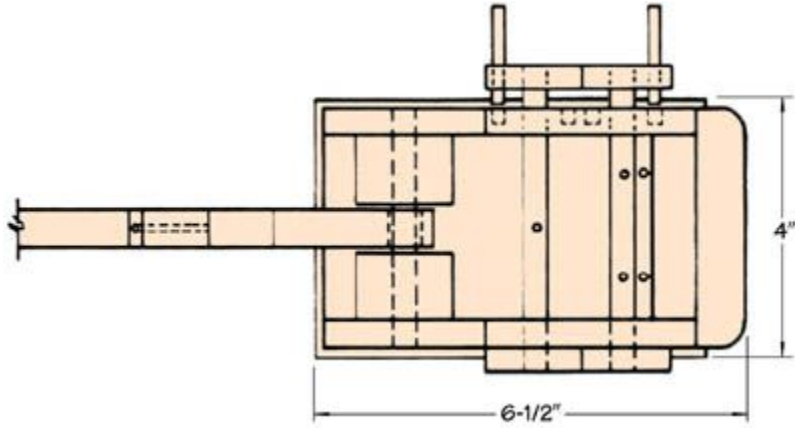

HAND-TURNED WOODEN CHESS PIECES



A larger-than-life set that could sell for big dollars, depending on the woods you use. A little larger than most standard chess pieces, this set is still a great fit for any chessboard with typical 2-inch squares. As any chess player knows, with the exception of the Knight, most chess pieces could be turned easily on a lathe...making a fantastic project for practicing your spindle turning techniques.

Now, thanks to some pretty ingenious thinking, you can turn the entire set on the lathe, including the Knight! Our turned Knight was created by using an offset turning technique; much like the one used for turning cabriole legs for furniture.

Step 1: Start by choosing a couple of contrasting hardwoods to turn them from. Walnut & Maple, Pear & Wenge, Beech & Ebony, Holly & Cocobolo, the list is limitless. Due to heavy handling of chess pieces, unless you're planning to apply a hard cover coat such as polyurethane or varnish, closed grain woods are usually better than open grained woods. The more highly figured and striking the pieces look, the more they'll be worth to your customers.

Print out the patterns -- they are at 100% of size (each square should = 1/4-inch). If you'd like to make a smaller and/or a larger set, just reduce or enlarge your printout accordingly.

Turn the Kings, Queens, Bishops, Rooks and Pawns according to the patterns. You can create a set of long templates (or patterns for duplicator-turned pieces), each designed to turn rows of multiple pieces

Step 2: When you're ready for the Knights, mount your stock on center and first turn just the base and part of the head (see [Figure 1](#)). Then, set the



head end of your stock 3/8-inch off-center (see [Figure 2](#)) on the tailstock end. Turn the neck of the Knight (see [Figure 3](#)). While the piece is still mounted off-center, sand the neck smooth.

Move the Knight back on-center and finish turning the head, stopping just before cutting the piece free (see [Figure 4](#)). Now, sand the rest of the piece.

Step 3: Once you've finished with the turning, a little hand sawing and "carving" will be needed for the King's cross, Queen's crown, Bishop's miter and Rook's parapet.

For weighting, we suggest that you drill a 1/2-inch diameter hole, 3/4-inch deep in the bottom of each Chess Piece. Fill these holes to within 1/4-inch of the surface with small lead shot (from a sporting goods store or gun shop). Then, using a 1/2-inch Plug Cutter, make a 1/4-inch thick plug for each Chess Piece.

Step 4: Glue the plugs in position, sand off flush and apply a moisture-resistant finish. Glue felt circles under the weighted bases.

As for boards, there are many types, readily-available from a variety of sources. Practically everyone has a Chess/Checker board of some type. If not, they should have no difficulty finding one at retail, in a catalog or on the web.

Suggested retail price: Depends on whether you're planning to sell at flea markets or at "higher-class" (perhaps even juried) arts and crafts shows. Other determining factors include the fact that this set is a bit larger than a standard chess set...and, of course, the species of wood you use to make the pieces and how highly figured and beautiful they are when completed. Taking these factors into consideration, we would estimate the potential retail for each set to be in the \$200 to \$350 neighborhood.

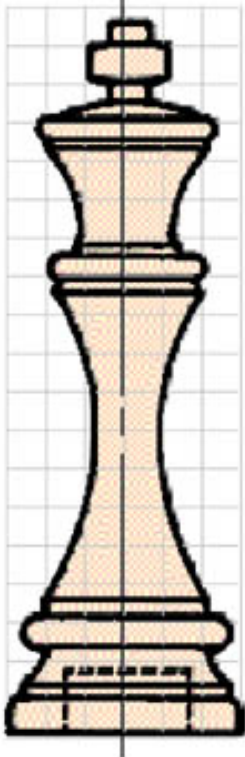

KING

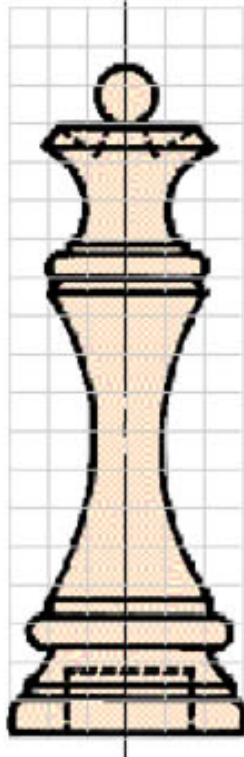

QUEEN

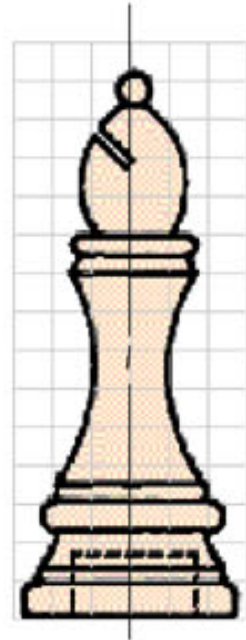

BISHOP

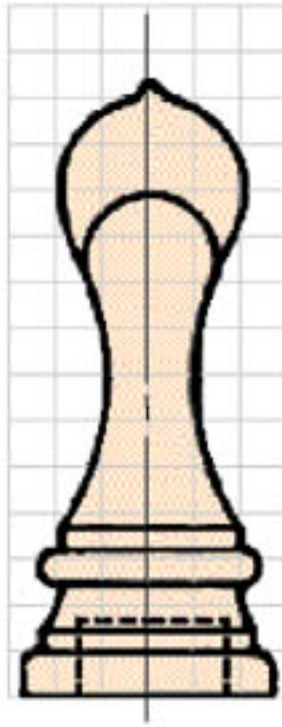
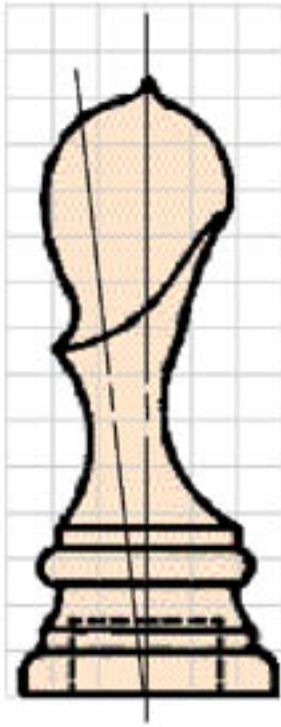

KNIGHT

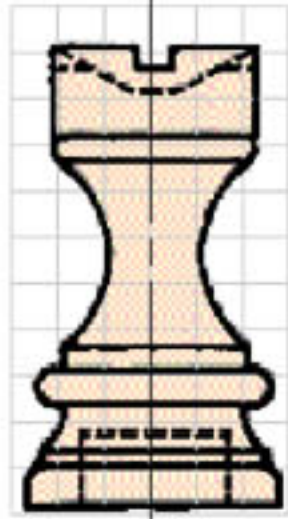
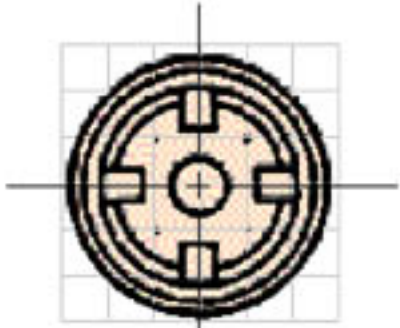

ROOK

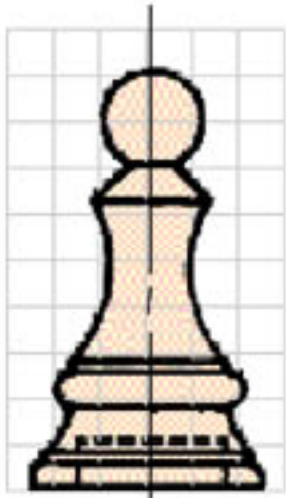

PAWN

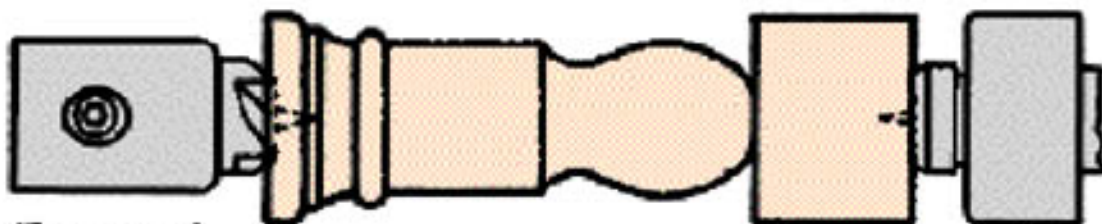

FIGURE 1

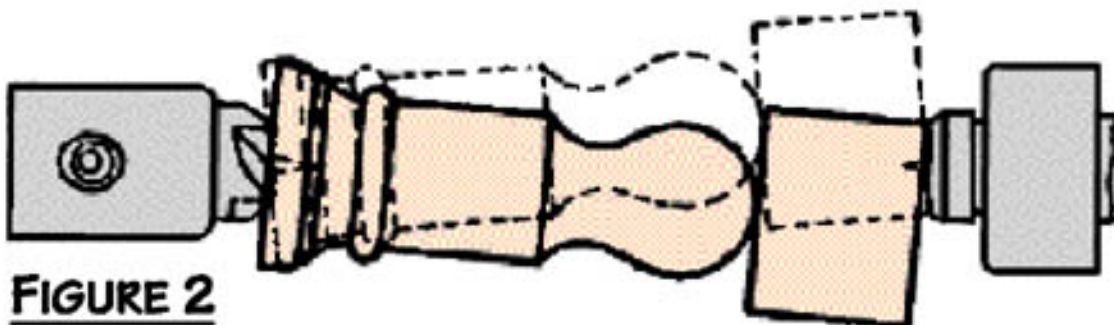

FIGURE 2

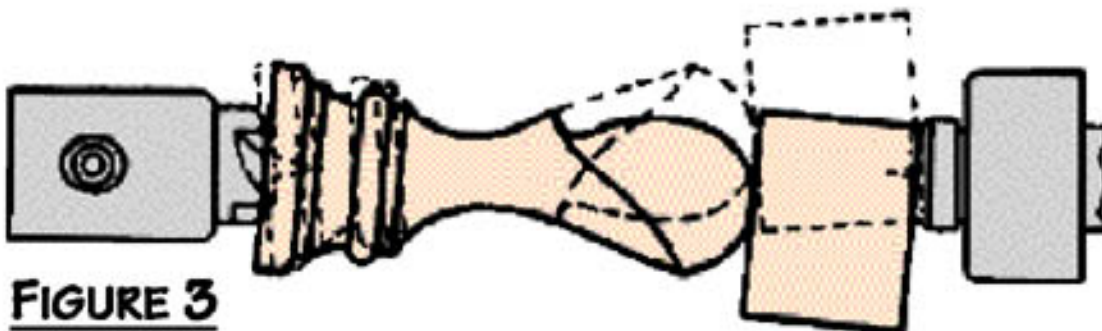

FIGURE 3

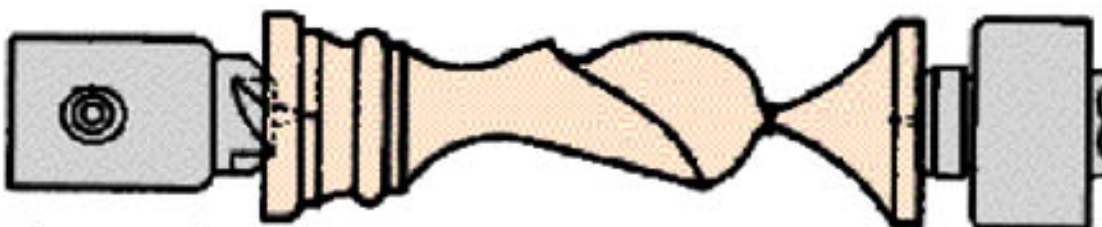

FIGURE 4



2001 Archive



PORCH SWING-1

You'll never find a Porch Swing of this quality at retail !It's built to last a lifetime — all in a single weekend



Spring is almost upon us. Soon, our thoughts will turn to outdoor activities . . . barbecues on the deck or patio . . . a dip in the pool (if we're fortunate enough to have one)...back yard get-togethers . . . gardening . . . cutting the grass . . . let's stop here, while we're ahead!

Yes, just as sure as there are lots of "fun" things to do outside in the Spring and Summer, there are also those yard-related chores that we must all attend to. And what better place to sit down and enjoy a relaxing evening after the day's activities than on your own

This one's a real "beauty" -- and by following the plans we've included here, you can make this Swing yourself easily and quickly in about a week-end. When you've finished, you'll have a Porch Swing to rival any of the old "classics" you could hope to find at an antique shop, garage sale or flea market. And the best part of all is that you will have built it yourself ! Before we get started, here are a couple of important points for consideration:

STEP 1: Plane your stock for the three back supports (B), three bottom supports (C) and 21 slats (A) to the desired thickness. Our guidelines call for 7/8-inch, 7/8-inch and 5/8-inch, respectively. Remember, you may choose to make these parts thicker if you are lengthening the swing or using lumber that may not be as strong as oak.

STEP 2: Cut the back supports (B), bottom supports (C) and slats (A) to size/length, according to the List of Materials.

STEP 3: Using your bandsaw or scroll saw, cut out the contours for the back and bottom supports (B & C). For best results, use the pad sawing technique with double-faced tape to cut multiples of the same profile at the same time.



STEP 4: Using your drum sander, sand all the support profiles (B & C) while they're still taped together.

STEP 5: Again . . . while they're still taped together . . . drill 3/8-inch diameter holes at the locations indicated in the support pattern.

STEP 6: Untape the back and bottom supports (B & C) and assemble them with carriage bolts, washers and nuts. Tighten securely (see Support Assembly).

STEP 7: Mount one slat (A) to the flats on the front edges of two of your bottom supports (C) — and another slat (A) to the flats on the top edges of two of your back supports (B).

NOTE: Be sure to allow EXACTLY 1-1/2-INCHES of overhang on each end of your slats. Use your #8 x 1-1/2-inch wood screws, pilot-drilling and countersinking all screw holes in your slats, as well as your bottom and back supports, prior to assembly.

STEP 8: Place your center assembled support (or two, if you're lengthening the swing) so it's spaced evenly between the two side supports and attach the support to the two slats using 1-1/2-inch wood screws.

STEP 9: Using a couple of 1/4-inch thick pieces of hardboard or plywood as spacers, mount the remainder of the slats (A) to the back and bottom supports using 1-1/2-inch wood screws on each end and in the middle.

STEP 10: Plane the stock for the arm rests (D), arm braces (E) and arm posts (F).

STEP 11: Cut the arm rests (D), arm braces (E) and arm posts (F) to size, according to the List of Materials.

STEP 12: Again, using your bandsaw or scrollsaw, cut the contours for the arm rests (D) and sand smooth using your drum sander .

STEP 13: Bore a 3/8-inch diameter hole, 2-inches from the top ends of the front arm posts (F) . . . and another hole 1-1/8-inch from the bottom ends of the front arm posts (F).

STEP 14: Using your 1-1/2-inch wood screws, attach the arm braces (E) to each side of the tops of the arm posts (F) as shown in the End View.

STEP 15: Remove any slats (A) which may be located at the points where the arm assemblies connect to the bottom and back supports of the swing.



STEP 16: Using clamps, temporarily mount the arm posts (F) to the outsides of the bottom and back supports, as shown.

STEP 17: With four clamps holding the posts (F) in position, bore your 3/8-inch diameter mounting holes through the arm supports and the bottom supports. Secure with carriage bolts, washers and nuts.

STEP 19: Attach the back ends of the arm rests (D) to the outsides of the two back supports, using two 1-1/2-inch wood screws (counterbored, if necessary) on each arm end.

STEP 20: Cut the slats you removed previously so they fit around the backs of the arm rests (D) and the arm posts (F). Replace the slats and screw them back into position.

STEP 21: Attach the eye bolts as indicated.

NOTE: When tightened, the eyes should be positioned vertically so the closed portions of their loops are at the top.

STEP 22: Finish with polyurethane or the finish of your choice.

STEP 23: Hang securely with chain and enjoy!

List of Materials

(finished dimensions in inches)

A	Slats (21)	3/8 x 1-1/2 x 52
B	Back Supports (3)	7/8 x 2-1/2 x 19-1/4
C	Bottom Supports (3)	..	7/8 x 2-1/2 x 19-1/4
D	Arm Rests (2)	3/4 x 4 x 23-1/2
E	Arm Braces (4)	3/4 x 1-1/2 x 13
F	Arm Posts (4)	7/8 x 1-1/2 x 9-1/2

Hardware

(all dimensions in inches)

	Eye Bolts (2) – Heavy Gauge	3/8 x 4
	Carriage Bolts (10)	3/8 x 2-1/2
	Washers (14) – To fit Carriage Bolts	3/8
	Nuts (14) – To fit Carriage Bolts	3/8
	Brass Wood Screws (68)	#8 x 1-1/4
	Brass Wood Screws (6)	#8 x 1
	Heavy-Gauge Chain	25 feet

End View Assembly

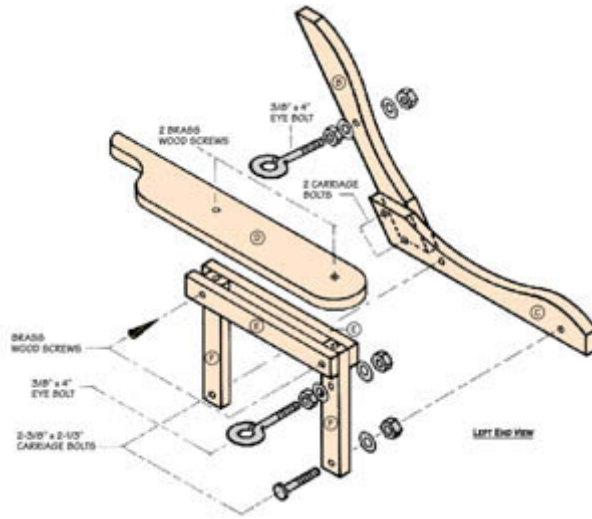

Arm Rest Pattern

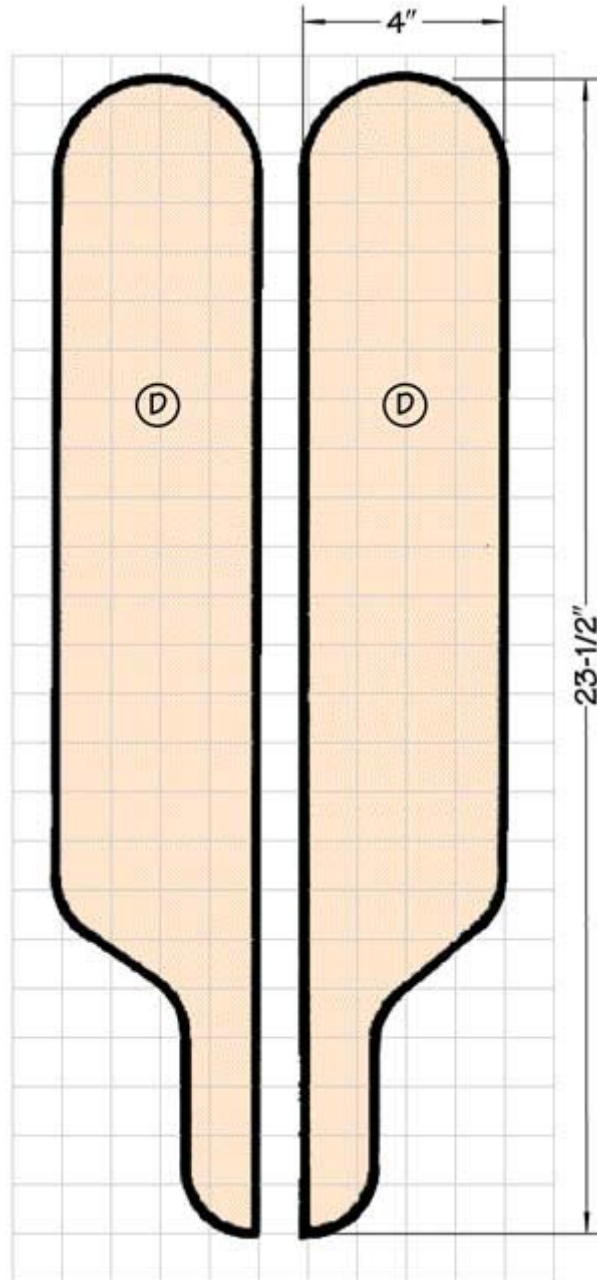

ARM RESTS – 1 square equals 1 inch

Bottom Support Pattern

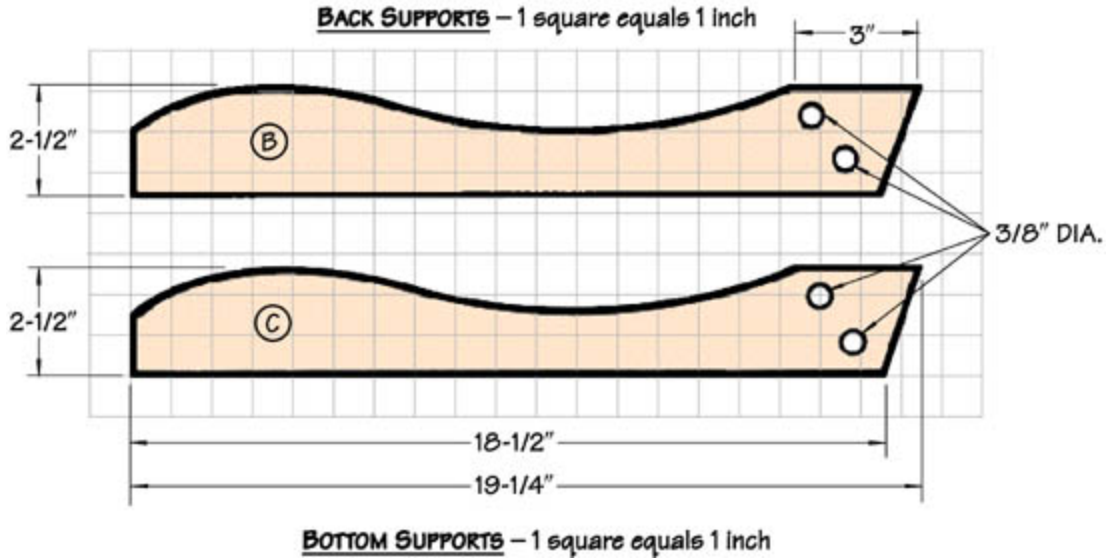

Support Assembly and Pattern

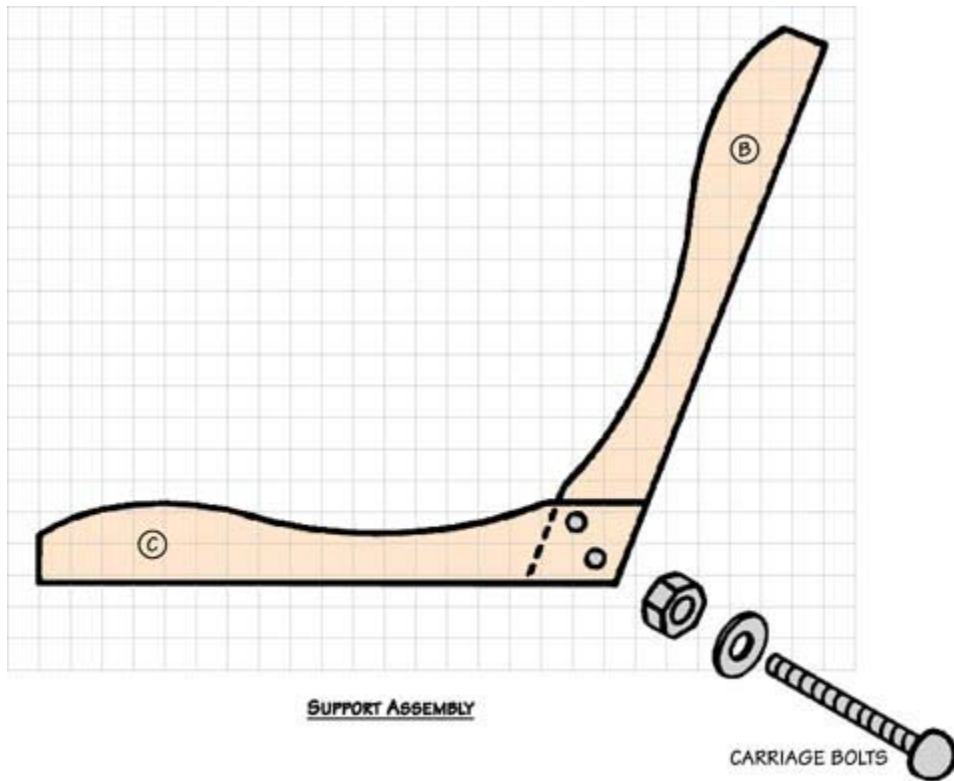

Assembled Swing

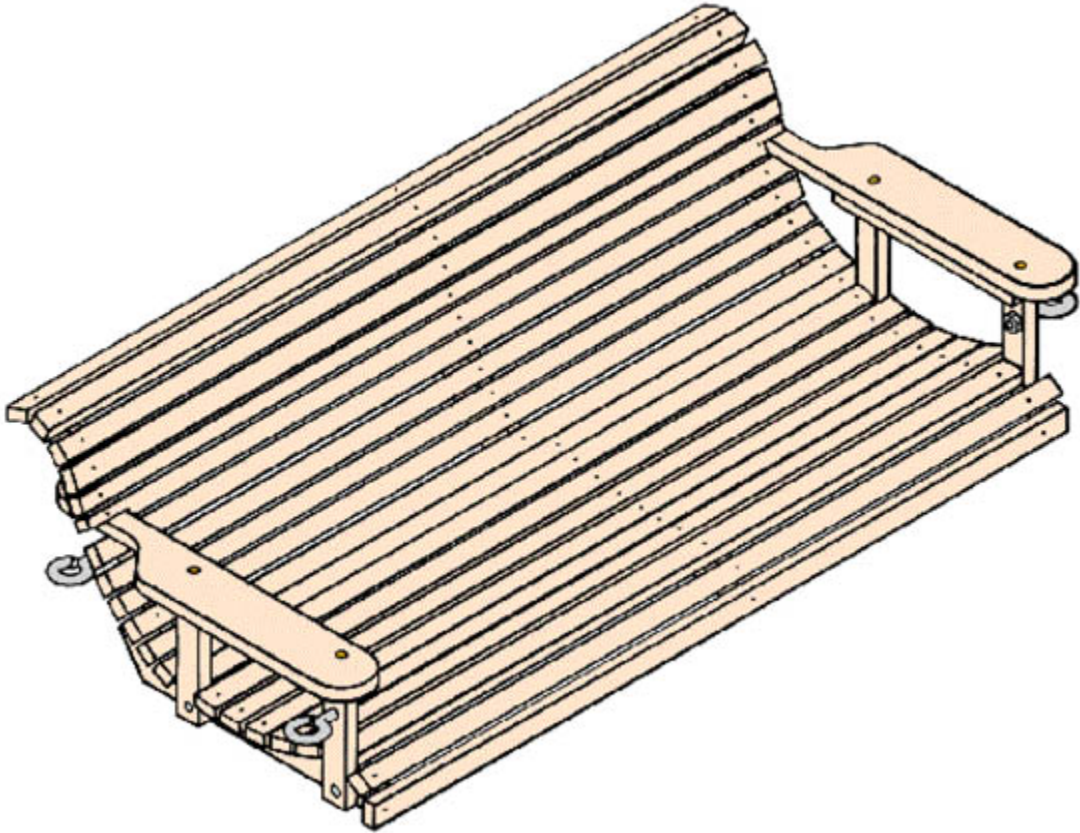

ROLL-AROUND BARBECUE CART



This easy-to-build Barbecue Cart will solve both of those problems for you. First, it comes complete with two spacious drawers, a condiment organizer, a utensil holder, a slide-out cutting board/shelf and plenty of space for all the cooking "stuff" you'll be needing. The laminate-covered top offers plenty of space for food preparation and "staging" . . . it's conveniently portable . . . plus . . . it's attractive enough to fit in, no matter where you may choose to store it between cook-outs.

We made our example from red oak with a white laminate-covered top and lower shelf. If you're planning to leave the table outside, be sure to choose a weatherproof wood like red cedar , redwood or cypress for the basic construction and use waterproof glue and brass screws to put everything together.

1. First, cut all workpieces to size, following the dimensions outlined in the *List of Materials*.

NOTE: Be sure to allow all glued-up sub-assemblies to dry completely for 24 hours before putting them together with other sub-assemblies.

2. Using your drill press, drill (16) 3/8-inch diameter by 9/16-inch deep dowel holes in pieces B, C and D, and glue the facing assembly together, using 3/8-inch diameter by 1-inch long dowel pins as shown in Figure 1.

3. Use your dado set-up or bandsaw to cut a 10-7/16-inch wide by 1-9/16-inch deep notch in the left side of the base assembly (F) to accommodate the pull-out shelf/cutting board, which will be installed later. See Figure 2.

4. Drill (50) 3/8-inch diameter by 9/16-inch deep dowel holes in pieces A, E,



F and G as shown in Figure 2. Assemble all pieces together (including the facing sub-assembly you made in step #2, above) using 3/8-inch diameter by 1-inch long dowel pins.

5. Mount cleats (L) to the insides of the four legs (G) as shown in Figure 4, using 3/8-inch diameter x 1-inch long dowel pins. Position them 7-1/4 inches down from the tops of the legs (G) or sides (F).

6. Cut 1/4-inch by 3/8-inch deep tongue & groove joints in the web frame stiles and rails (pieces H, I and J), as shown in Figure 3.

7. Glue-up the web frame assembly as shown in Figure 3.

8. Mount the web frame assembly to the top surfaces of the cleats you glued into position in step #5, above, using four 1-1/4-inch x #8 wood screws. See Figures 3 & 4

9. Cut the dado and rabbet joints in the drawer fronts and backs (parts W) and the drawer sides (parts V), as shown in Figure 5.

10. Cut the 1-inch wide by 1/4-inch deep notches in the drawer fronts/backs (parts W) (see Figure 5). These notches will slide on the drawer runners (parts K, Figure 3) when assembled.

11. Using glue, assemble the drawer sides (V) front/back (W) and bottom (X), as shown in Figure 5.

12. Using the drawer assemblies you made in step 11, above as guides, glue the drawer runners (K) to the web frame assembly as shown in Figure 3. Be sure the drawers slide smoothly in and out before leaving the runners to dry.

13. Using a router or belt sander, round-over the edges of the false drawer fronts (Y).

14. Glue the false drawer fronts (Y) to the fronts of the drawer assemblies (See Figure 5).

15. Construct the shelf support assembly (M, N, O, P, R in Figure 6) using 1-1/4" x #6 wood screws.

TIP: Drill pilot holes for screws first to ease the assembly process.

16. Mount the completed shelf support assembly (Figure 6) to the base assembly (Figure 2), using 1-1/4-inch x #8 wood screws. See Figures 6 & 7.



- 17.** Drill a 1/4-inch diameter by 1/2-inch deep hole, in a centered position, approximately 1/2-inch in from the back edge of the slide-out cutting board/shelf (part Q). Be sure this hole is in the TOP surface of the board. This protruding dowel will serve as a stop to keep shelf from pulling out completely. We'll glue this stop into position later.
- 18.** Cut the miters for the bottom shelf front, back and side rails (parts S & T). See Figure 8.
- 19.** Assemble the bottom shelf with 3/8-inch diameter x 1-inch long dowel pins and glue. **NOTE:** Be sure to apply a liberal coat of glue around all edges of the top (U) to prevent any moisture or spills from seeping into the laminate substrate. If you're planning to leave your Cart outdoors, use waterproof glue. See Figure 8.
- 20.** Attach the bottom shelf assembly you made in step 19 to the four legs (G) using 1-1/4-inch x #8 wood screws. We suggest that the shelf be positioned about 10-inch or so up from the bottoms of the legs. It's your choice. See Figure 9.
- 21.** Cut the miters for the front, back and side rails (AA & BB) of the Cart to assembly (See Figure 10). Next, cut out the utensil holder (CC) and condiment holder (DD) pieces. See Figure 10.
- 22.** Using glue and 3/8-inch diameter x 1-inch dowels, put the top assembly together (Z, AA, BB). **NOTE:** Be sure to apply a liberal coat of glue around all edges of the top (Z) to prevent any moisture or spills from seeping into the laminate substrate. If you're planning to leave your Cart outdoors, use waterproof glue. See Figure 10.
- 23.** Mount the top assembly to the base assembly, using 1-1/4-inch x #8 wood screws. See Figure 11.
- 24.** Mount the utensil holder (CC) to the side of the top assembly using two 1-1/4-inch x #8 wood screws. See Figure 10.
- 25.** Round the edges of the condiment holder using a belt sander or router and mount it to the laminate top with four 1-1/4-inch x #6 wood screws. See Figure 10. If you prefer, counterbore the screw holes and fill them with wooden plugs.
- 26.** Finish sand the entire Cart. Be careful not to scuff your laminate surfaces in the process.



27. Apply a stain, oil or other finish of your choice.
28. Install the slide-out cutting board/shelf (Q) and glue the 1/4-inch dowel pin into position as a stop.
29. Mount the pulls of your choice on the drawers and slide-out shelf.
30. Mount the casters
31. Enjoy

List of Materials

(finished dimensions in inches)

Facing Assembly – Figure 1

- A Stiles (2) 3/4 x 1-1/2 x 8
- B Stile-Middle (1) 3/4 x 1-1/2 x 4-1/4
- C Top Rail (1) 3/4 x 2-1/4 x 17
- D Bottom Rail (1) 3/4 x 1-1/2 x 17

Base Assembly – Figure 2

- E Back 3/4 x 8 x 20
- F Sides (2) 3/4 x 8 x 14-1/2
- G Legs (4) 2 x 2 x 38

Web Frame Assembly – Figures 3 & 4

- H Stiles (2) 3/4 x 2-1/2 x 17
- I Rails (2) 3/4 x 2-1/2 x 15-3/4
- J Stile-Middle (1) 3/4 x 2-1/2 x 12-3/4
- K Drawer Runners (2) 1/4 x 1 x 16
- L Cleats (2) 3/4 x 2-1/2 x 16-7/8

Shelf Support Assembly – Figures 6 & 7

- M Sides (2) 3/4 x 1-5/8 x 22-1/4
- N Back Brace (1) 3/4 x 1-5/8 x 12-3/4
- O Front Brace (1) 3/4 x 3/4 x 12-3/4
- P Guides (2) 3/4 x 1-1/4 x 10-3/4
- Q Slide-Out Shelf (1) 11/16 x 10-3/8 x 11-1/16
- R Bottom-Hardboard (1) .. 1/8 x 14-1/2 x 11

Bottom Shelf Assembly – Figures 8 & 9

- S Front/Back Rails (2) 3/4 x 1-1/2 x 20
- T Side Rails (2) 3/4 x 1-1/2 x 18-1/2
- U Top-Laminate (1) 3/4 x 17 x 18-1/2

Drawer Assembly – Figure 5

- V Sides (4) 5/8 x 4-1/16 x 16
- W Fronts/Backs (4) 5/8 x 4-1/16 x 6-7/8
- X Bottoms (2) 1/4 x 6-3/4 x 15-1/8
- Y False Fronts (2) 3/8 x 5 x 8-1/2

Top Assembly – Figure 10

- Z Top-Laminate (1) 3/4 x 17 x 18-1/2
- AA Side Rails (2) 3/4 x 1-1/2 x 20-1/4
- BB Front/Back Rails (2) .. 3/4 x 1-1/2 x 25-3/4

Accessory Add-Ons

- CC Utensil Holder (1) 3/4 x 2 x 17-5/8
- DD Condiments Holder 3/4 x 4 x 18

Hardware

- 1-1/4-inch x #8 Wood Screws (20)
- 1-1/4-inch x #6 Wood Screws (14)
- Wooden Screw Plugs – Optional (4)
- 1-inch x 3/8-inch Dowel Pins (62)
- 1-inch x 1/4-inch Dowel Pins (1)
- Drawer Pulls (2)
- Sliding Shelf Pull (1)
- Casters (4)

Fig. 1 – Facing Assembly Detail

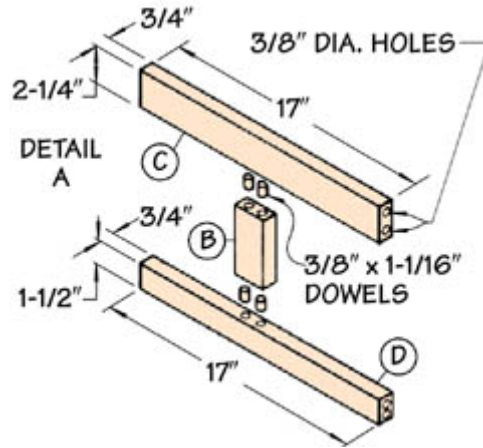

Fig 2 – Facing Assembly Detail

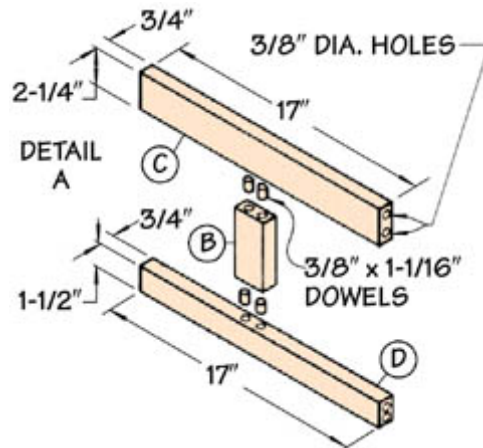

Fig 3 – Bottom Web Assembly Detail

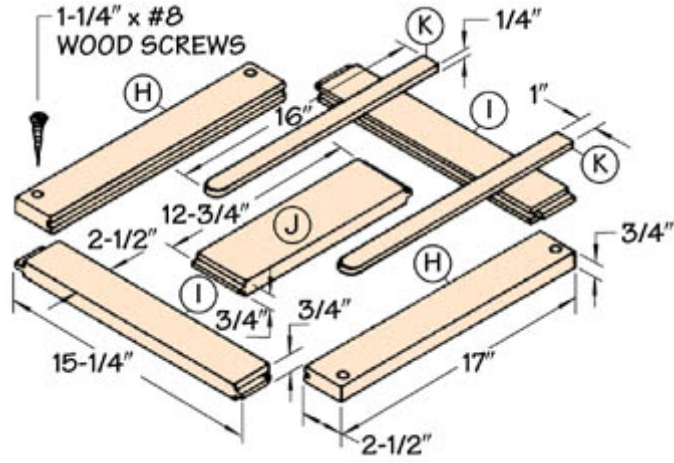

Fig 4 - Bottom Web Frame

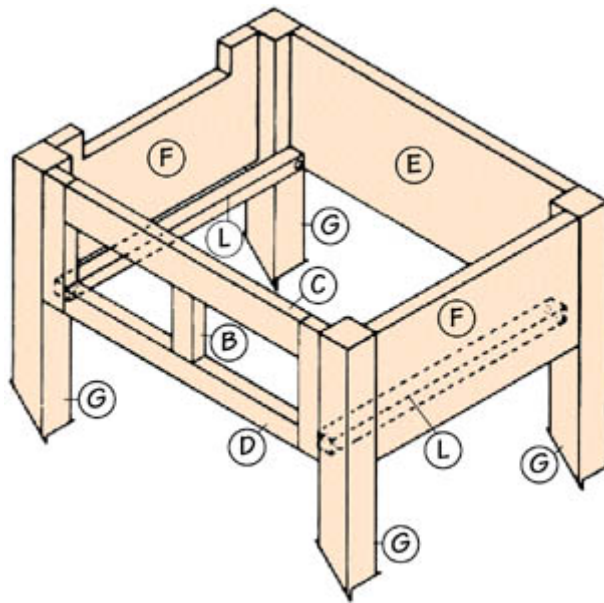

Fig 5 - Drawers

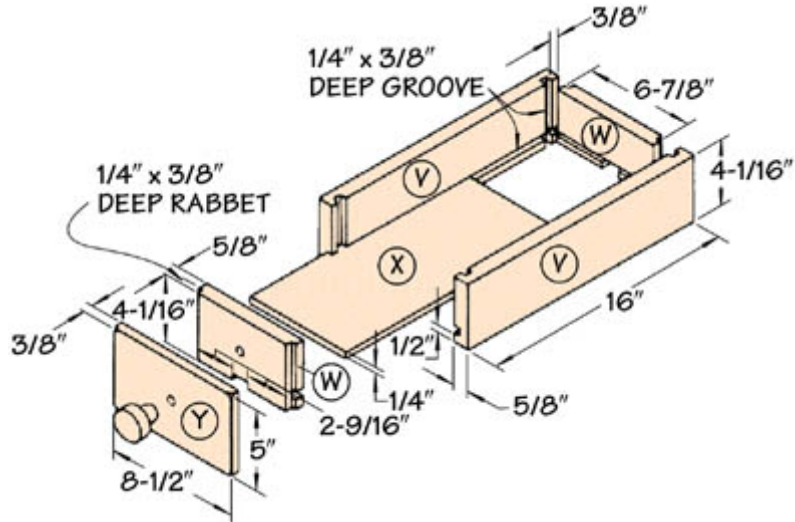

Fig 6 – Shelf Support Detail

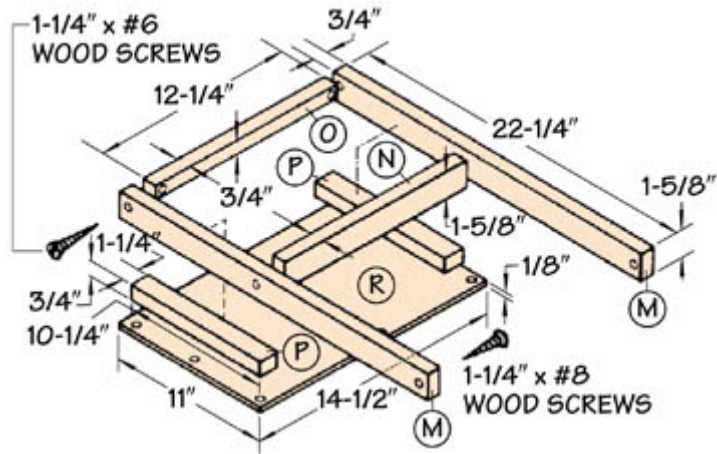

Fig 7 – Shelf Support Assembly

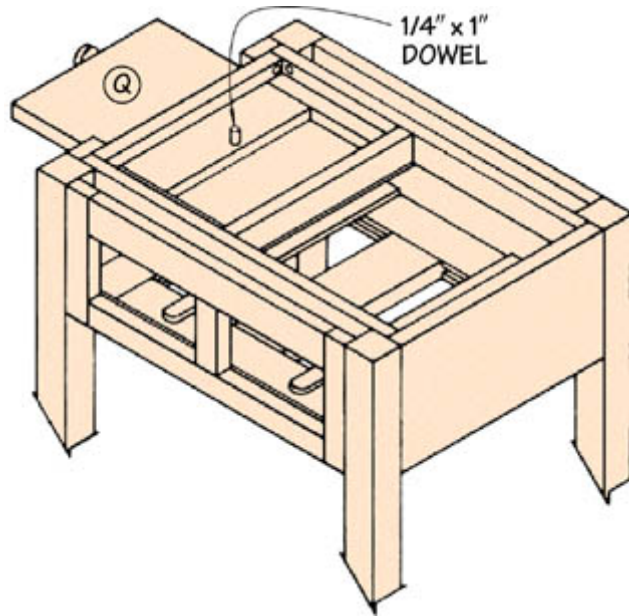

Fig 8 – Bottom Shelf Detail

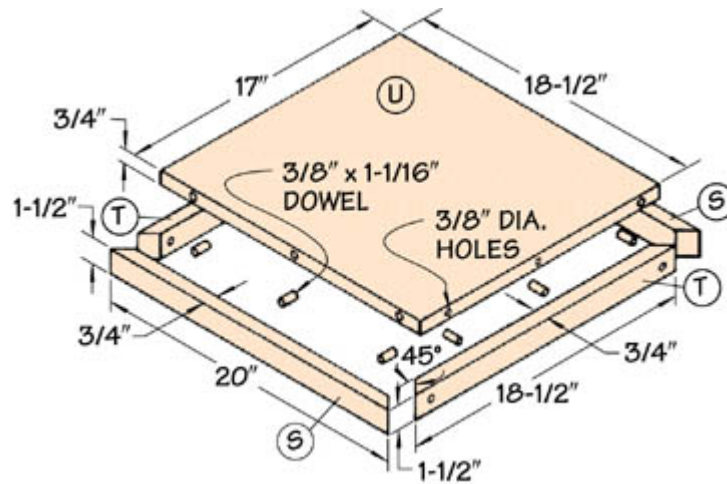

Fig 9 – Bottom shelf Assembly

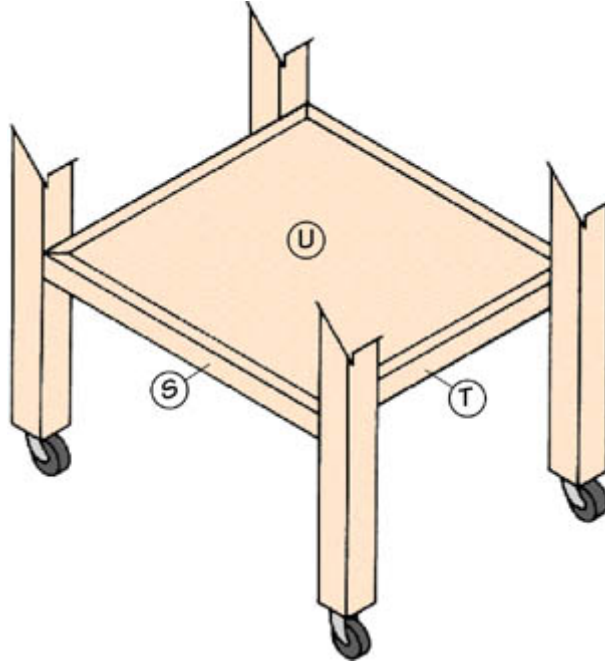

Fig 10 – Top Detail

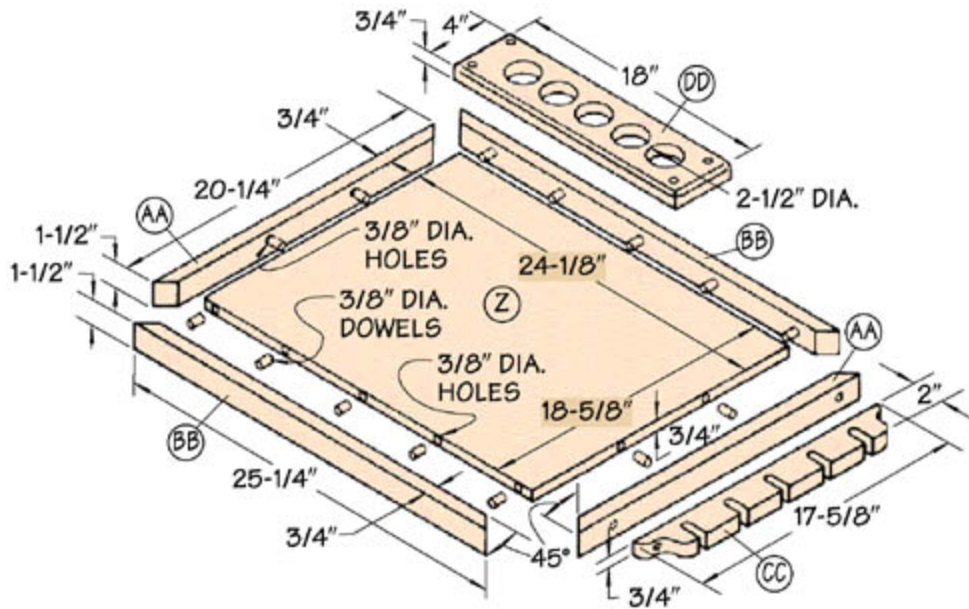
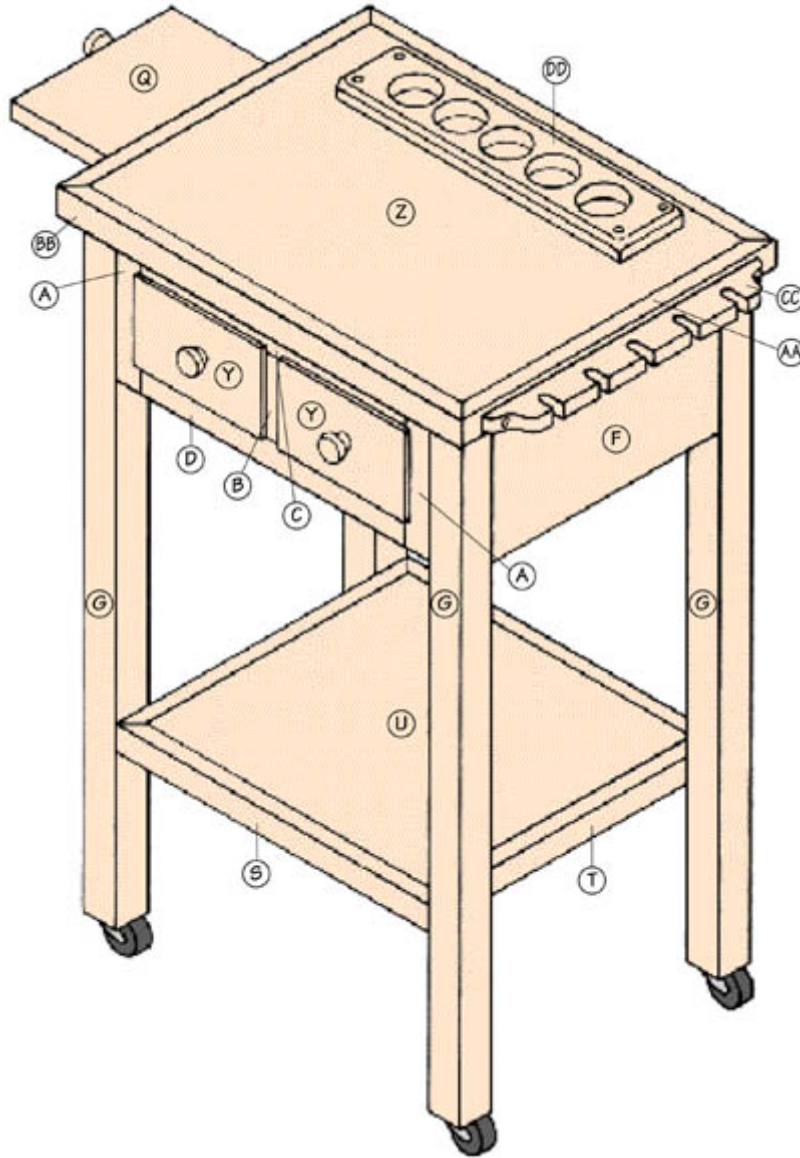

Fig 11 –Final Assembly



PATIO DECK TABLE

Build one or a set of these handy little tables in a single weekend



Here's an interesting example of a project that's not only quick and easy to build . . . it also provides an excellent opportunity for you to experiment with furniture design. Why? Because of its extremely simple construction. For example, the table shown here is a 20-1/2-inches square end table design. However, it could just as easily be a 36-inches long x 16-inches high cocktail table . . . or a 30-inches high x 36-inches square dining table . . . or any combination of dimensions you may need.

By merely altering the width, length or number of top slat boards, you can create your own different and unique top configurations. Changing leg heights will give you low tables for end tables, cocktail tables or plant stands -- or higher tables for food preparation, dining or potting your plants. Make the legs and side rails of heavier lumber and you can create sturdy, comfortable benches for patio or deck seating. The options are virtually endless.

This project will also show you (in case you don't already know) how the simplest machine set-ups can make quick work of repetitive operations. Whenever you build a project like this, it just makes good sense to think about building more than one . . . providing you have a use for multiples, of course. Once you've set your table saw rip fence to cut 2-1/2-inches wide slats, it's just about as easy to cut twenty-eight of them as it is to cut seven. Once you've configured a miter-gauge or outboard-mounted cut-off stop, crosscutting fifty 20-inches long slats takes just a bit longer than cutting twenty-five of them.

We used weather-resistant, rough sawn Western red cedar for our example table. Other great woods for outdoor use include pressure-treated lumbers (read their warnings about use around food), cypress, redwood and teak. Be sure to use a glue that's designed for weatherproof, outdoor use for all your joints.



1. Set your table saw rip fence to 2-1/2-inches and rip the stock required for the seven table top slats (A), according to the List of Materials.
2. Move your rip fence to 2-inches and rip the stock required for the four side rails (B).
3. Adjust your fence again to 1-1/2-inches and rip the stock for the four legs (C).
4. Using simple cut-off stops, crosscut your stock to length for the top slats (A), side rails (B) and legs (C), according to the list of materials.

TIP: If you're planning to make a table with components that are 24-inches long or shorter, Shopsmith's optional adjustable Extension Face attaches quickly to your Miter Gauge to provide added efficiency and precision when cutting duplicate workpieces.

5. Tilt your saw table (or arbor) to 45-degrees and cut the mitered corners for the ends of the side rails (see detail A).
6. While at a 45-degrees tilt, adjust your saw's depth-of-cut and cut the saw kerfs for the splines that are used to reinforce the mitered corners (see detail A).
7. Carefully measure the width of the kerfs you just cut so you can make the splines (D) that glue into them as thick as your kerfs are wide.
8. Using your drill press set-up, bore the 3/8-inch holes in the ends of the top slats (A) and the sides of the side rails (B), where they attach to the legs (C).
9. Dry assemble and clamp the side rails (B) together. Be careful to maintain squareness during assembly. Once you're confident of a proper fit, apply glue to the mitered ends, insert the corner splines and clamp the assembly together.
10. Using a dado blade, cut the half-lap joints on two sides of each leg top (see detail A). Make them 2-inches high x 3/4-inch deep to accept your side rails.
11. Glue and clamp the legs (C) into the four corners of the side rail assembly, as shown. Be sure everything is square.



12. Once the glue has dried, use the dowel holes you drilled in the rail sides as guides while you bore the other half of your reinforcing dowel hole in the leg tops with a 3/8-inch bit and portable drill.

13. Glue and clamp the top slats (A) to the side rails (B), using 1/2-inch wide spacer blocks at each end to keep everything square and even during assembly. Once each slat is clamped firmly, move your spacers to the next position and install the next slat.

14. Once the slats have dried in position, remove the clamps. Using the dowel holes drilled in the slat ends as guides, bore the reinforcing dowel holes in the top edges of the rails with a 3/8-inch bit in your portable drill.

15. Sand smooth and apply a finish, if you prefer. Remember that although outdoor woods usually require no finish, spar varnish or exterior grade polyurethane will provide added protection and longevity.

List of Materials

(finished dimensions in inches)

A	Table Top Slats (7) – Red Cedar	5/8 x 2-1/2 x 20-1/2
B	Side Rails (4) – Red Cedar	3/4 x 2 x 20-1/2
C	Legs (4) – Red Cedar	1-1/2 x 1-1/2 x 15-3/8
D	Splines (4) – Oak	1/4 x 3/4 x 2
E	Dowels (36) – Oak	3/8 diameter x 1-1/2

Top View

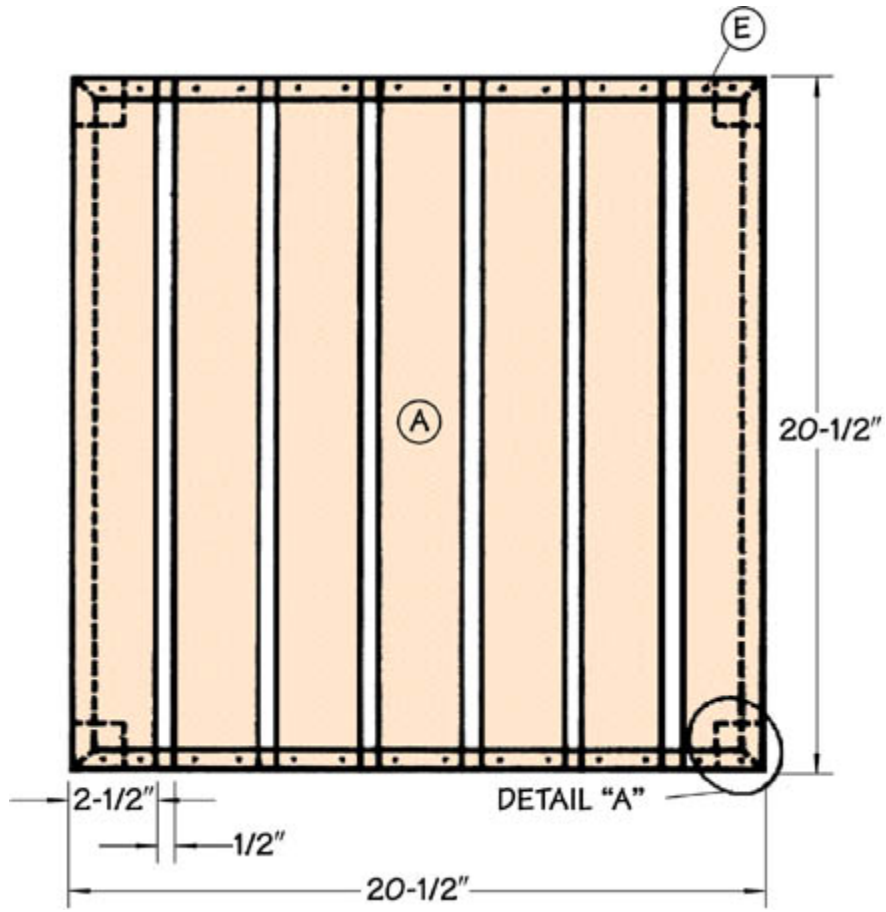

Front View

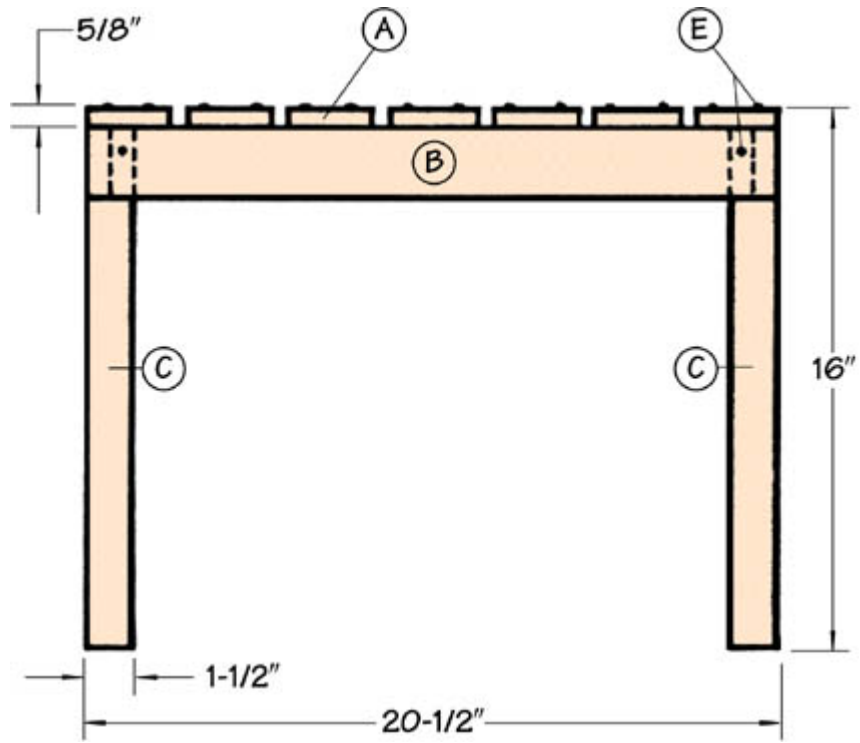

Detail A

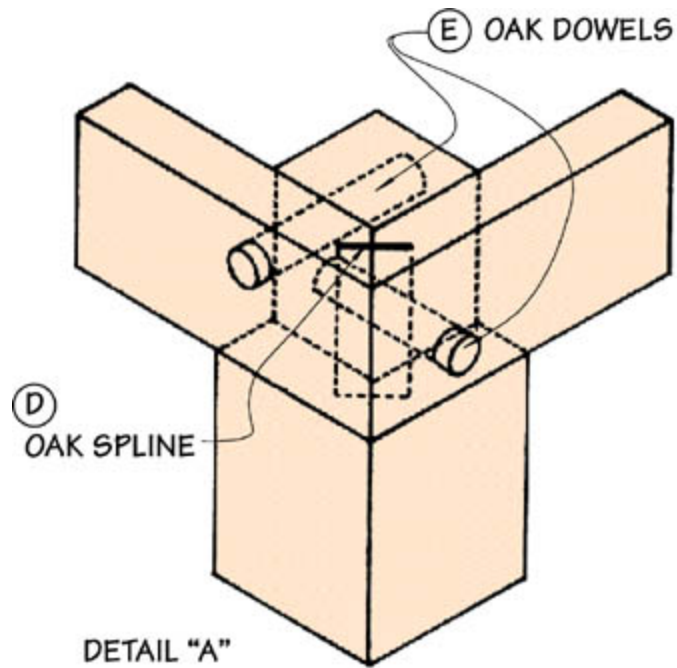

CURIO CABINET



Here's a project that makes a perfect "showplace" for your collections and other treasured items. It's also one that's excellent for learning how to use a variety of your versatile MARK V accessories.

Note: This plan is from Shopsmith, so it will reference Shopsmith parts.

We chose walnut for our cabinet, but any hardwood will work quite nicely. Its doors, sides and upper & lower backs are frame-and-panel construction, made using Shopsmith's Cabinet Set Shaper Cutters. The mirrored back and see-through glass shelves provide an excellent all-around view of the treasured items on display.

We started by cutting all the stiles (A,B,C) and rails (D,E,F,G) to size, as listed in the Bill of Materials. Go ahead and cut them to exact size now, as this will make it easier to clamp and glue them together later. Do be aware, however, that doing so means you'll have to be careful when you mill them on the shaper, since you will have no margin for error.

While you're cutting things out, make an extra 2-inch wide rail and stile to use as test pieces for setting-up your shaper cuts



Shaper Set-Up

With your shaper table set at waist height so you have optimum control, position your shaper fence and table so the shaper cutter clears your miter gauge by about 1/4-inch. Use a miter gauge stop rod or a wood dowel mounted in the stop rod holes of your miter gauge to set your shaper fence so it's parallel to the miter gauge slot, from one side of the table to the other and tighten the fence to the table surface.

Coping Cut Set-Up

Install one of the 3/8-inch coping cutters and the 1/4-inch (short) straight cutter on your arbor (The coping cutter is the cutter used to form the female half of your two-part joint on the ends of your door rails). Put your smallest rub collar on your arbor first -- then your coping cutter (its ogee edge UP towards the arbor setscrew) -- then the 1/4-inch (short-wing) straight cutter below it, followed by the next smallest rub collar, the arbor washer and (tightened) nut. Be sure the two cutters are oriented with their cutting wings offset from one another (not aligned) and both cutting in the proper direction.

Install the arbor (with cutters attached) to the MARK V's spindle. NOTE: Be sure the arbor "bottoms-out" completely on the spindle before tightening. Adjust the infeed and outfeed halves of your shaper fence (right-to-left) to leave a minimum opening for the cutter. Rotate the cutter by hand to check this clearance.

CAUTION: Be sure your machine is unplugged before doing this!

Next, install a 3-inch high x 3/4-inch thick wooden extension to your miter gauge face. It should be long enough that its end just touches the Shaping fence once it's been adjusted to its final setting. This extension will serve as a backup to prevent splintering and tear-out on the exit side of your cross-grain cuts at the ends of your rails.

Using a soft lead pencil, cover one end of your test piece with a dark pencil mark. Adjust your fences and quill to make a FULL PROFILE cut in the ends of your rails. When the adjustment is correct, the cutting tips of your 1/4-inch straight cutter should be EVEN with the face of your fence and the curve of the ogee shape on the coping cutter should leave a 1/32-inch step at the end of the rail. It should NOT create a knife-edge.

Check your set-up by making a short cut on the END of your RAIL test piece (NOT the stile). If it's correct, your coping cutter will form the desired profile



while the 1/4-inch cutter mounted next to it will barely brush against the end of your rail, “smearing” the pencil lead without removing it.

REMEMBER: You must be sure to create a full profile cut without reducing the overall length of your rail pieces. There is a very narrow margin for error here if you want your joints to fit tightly. You may have to make a few test passes to achieve the correct adjustment. The first couple of these passes may not even touch your workpiece. That's OK. It's important that you take as much time with this set-up as necessary to get as close to perfect as possible. Once you're confident of your set-up, use your Miter Gauge and Safety Grip to keep your hands out of harm's way as you make your cuts in the ENDS of all RAILS.

Sticking Cut Set-Up

Without changing your table or fence settings, remove the arbor (with the cutter attached) from the shaper spindle. Change to the sticking cutter. This is the cutter used to form the mating male half of your two-part joint.

Put your smallest rub collar on your arbor first -- then your 11/16-inch sticking cutter (its ogee edge DOWN and away from the arbor setscrew) -- then the 1/4-inch (long-wing) straight cutter below it, followed by the next smallest rub collar, the arbor washer and (tightened) nut. Be sure the two cutters are oriented with their cutting wings offset from one another (not aligned) and both cutting in the proper direction.

Install the cutter on the spindle, being sure the arbor “bottoms-out”, as it did when you installed the coping cutter. Rotate the cutter by hand to once again verify all clearances to the fence and table. Adjust your vertical quill setting so the top surface of your 1/4-inch cutter is exactly even with the top surface of the tongue left on the end of test rail you cut earlier.

Next, install the quill-mounted feather board guard and the table-mounted feather board that came with your Shaper/Drum Sander Fence and adjust them so they hold your 2-inch wide test rail firmly against the table surface and the fence as you make your cut on the inside EDGE of your test RAIL.

Make your sticking cut on the inside EDGE of your 2-inches wide test STILE. Check the accuracy of your cut by matching-up the coping cut on the end of your test RAIL with the sticking cut you just made. Once you're satisfied that your cuts match-up, shape the inside EDGES of all rails and stiles, starting with the 2-inches wide pieces (A,B,C,D,F . . . then re-set your featherboard to shape the 2-3/4-inch wide pieces (E,G).



IMPORTANT NOTE: For more information about how to set-up and use our Complete Cabinet Set Shaper Cutters, visit the special article about these cutters in this issue of HandsOn!

Forming the Rabbets

Using your table saw with a Combination Blade and a Zero Clearance Table Insert, cut away the small 1/8-inch or so square scrap from the inside edges of all frame stiles and rails to create the 3/8-inch x 1/4-inch glass rabbets (see Section A-A). Take your time and be very careful when making your set-up for this cut, as any error here will affect the fit of all frame members.

Now, locate and drill the holes for the dowels used to hold the corners of the rails and stiles together, then locate and drill the holes for your glass shelf pins. Glue and assemble each frame, taking care to clamp them square, with end and edge surfaces flush. Remember that you cut these to exact size earlier, so you should have no extra stock to sand off, once assembled.

Next, set up and cut the 60-degree bevels on the sides of the frames. Remember that the back frames are cut at 60-degrees to the face side while the others are cut at 60-degrees to the back side. Now, locate, drill and countersink the screw holes used to assemble both back frames.

Using hardwood veneered plywood, make the cabinet base (K) and shelf (L). As an option, you could glue-up solid hardwood stock to make these pieces. Whichever option you choose, be sure to build them a little oversized. Once the glue has dried, use your jointer to true-up the back edge of each piece so it's straight and square. Cut the 60-degree angled edges, then rip and joint them to their finished size.

Milling the Moldings

The two small drawings labeled "Shaper Profile M" and "Shaper Profile N" show you how to set up your cutters to form the molding profiles. To make the base molding (N) and the shelf molding (M), start with a "blank" piece of 3/4-inch stock, about 4-1/4-inches wide and 40-inches to 42-inches long. As you did with the rail and stile pieces above, cut an extra piece of 3/4-inch x 4-1/4-inch stock for use as a test piece in making your set-ups. Make it about 12-inches to 18-inches long.

Starting with your test piece, make your set-ups to cut the shelf molding profile (N) on one edge of this stock. Use the Ogee Shaper Cutter (505932) and the Flute & Quarter-Round Shaper cutter (505934) to form the desired profile. Once you're satisfied with the profile on your test piece, cut the profile on the "real" piece.



Now, make your set-ups to cut the base molding profile (M) on the other edge of your test piece, using the same two cutters. As before, once you're satisfied with the profile on your test piece, cut the profile on the "real" piece. Once your two edge profiles are cut, rip the shelf molding (M) off to about 1-1/32-inches . . . and the base molding to its finished size of 3-inches. There's no need to make the base moldings oversize so you can joint them super-smooth since their straight edges sit on the floor and won't be seen anyway.

Use Shopsmith's Conical Sanding Disk (555477) or a hand plane to shave off the "proud" 1/32-inch and bring your 1-inch molding to its finished size.

Cut and fit these moldings as shown in the drawings. The short 1/4-inch dowels shown in the drawing are used to hold the shelf moldings to the shelf edges during glue-up. These are optional as you should be able to hold their position without them. Add glue blocks (V) behind the base moldings (N) for more support.

Locate and drill holes through the base (K) and shelf (L) for the 1/4-inch dowels used to position the frames. Hold each frame member in position and insert a 1/4-inch brad point drill bit through the hole in the base (K) and tap gently to mark the location of each dowel hole in the frame. Do this on frames to base (K), bottom frames to shelf (L), and shelf to glass frames. These dowels position the frames for assembly with screws. Cut and fit parts (Q,R) for the door opening spacer.

Making the Coved Top Moldings

Next, cut your stock to make the top cove moldings (P). The coved surface for this molding is cut with the table saw. See the Table Saw section of Power Tool Woodworking for Everyone (555069) for the proper cove cutting technique.

After you cut the cove in your molding, cut the 45-degree bevels on the FRONT side of your molding. Start by using a pencil to draw the desired 45-degree bevels on each end of your coved molding stock. Tilt your saw table to 45-degrees and place the COVED FACE of your molding on the saw table surface with one edge against the rip fence surface. Adjust your fence to make the bevel cut on one edge. Flip your stock end-for-end and make the identical cut on the opposite edge of your stock.

Now, turn your stock over so the FLAT BACK side is against the table surface and repeat the procedures outlined above, making the 45-degree cuts on the BACK side of your molding strip.



Cut and fit the top cove molding (P). Cut one of these miters with the table set at 90-degrees and the miter gauge at 60-degrees to the left in the left table slot. Cut its mate with the miter gauge at 60-degrees to the right in the right table slot. Cut both with the 45-degree back edges of the molding against the miter gauge and the table. Glue and fasten these to the top frame with screws.

Cut and fit parts (S,T) for the top frame. Spline the front miter joints (see Spline Detail Drawing). Cut the 1/4-inch x 1/4-inch rabbet on the top inside edges for the 1/4-inch hardboard top panel (U).

NOTE: Before assembling and gluing the top of the cabinet, make a cardboard pattern for the glass shelves. Your local glass shop will need this pattern to make the shelves for you. Be sure there's a 1/8-inch clearance around the perimeter of each glass shelf.

Now, assemble the top cabinet frame and attach it to the cabinet.

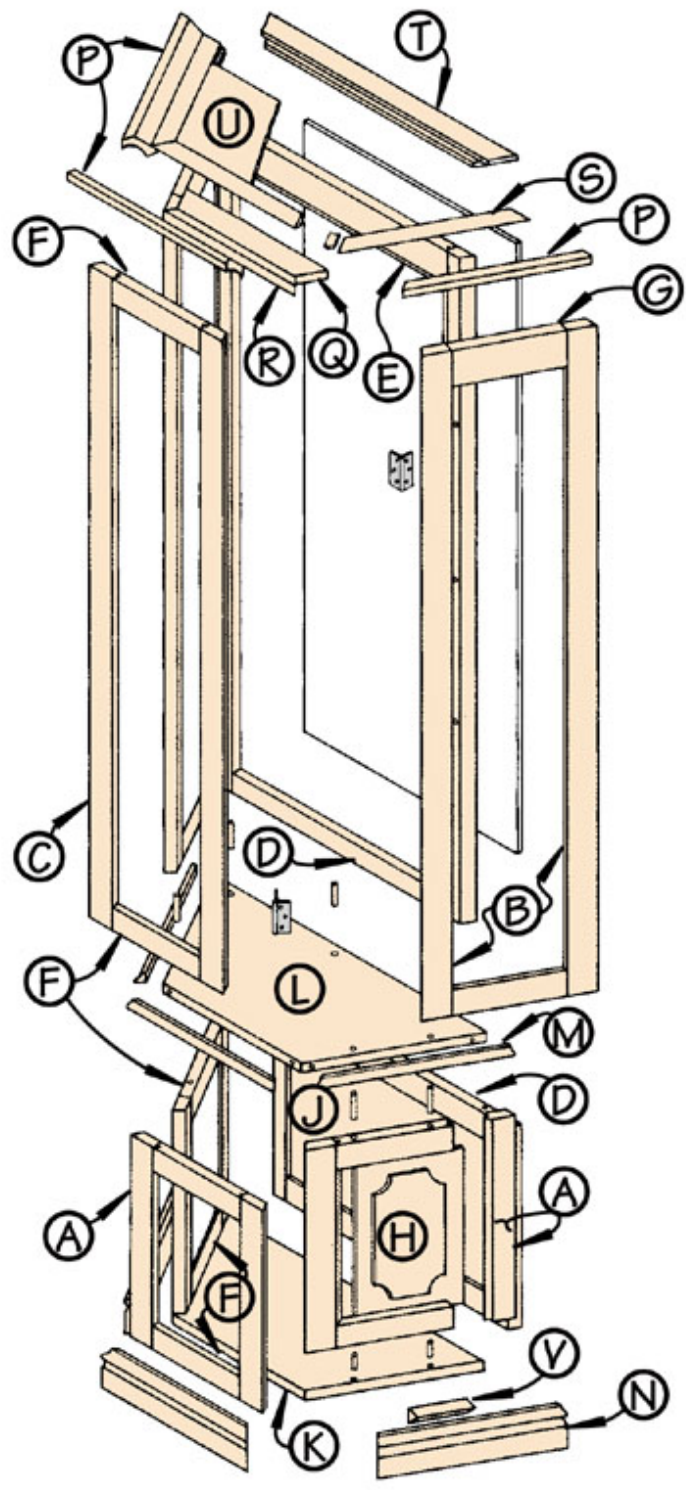

CABINET ASSEMBLY

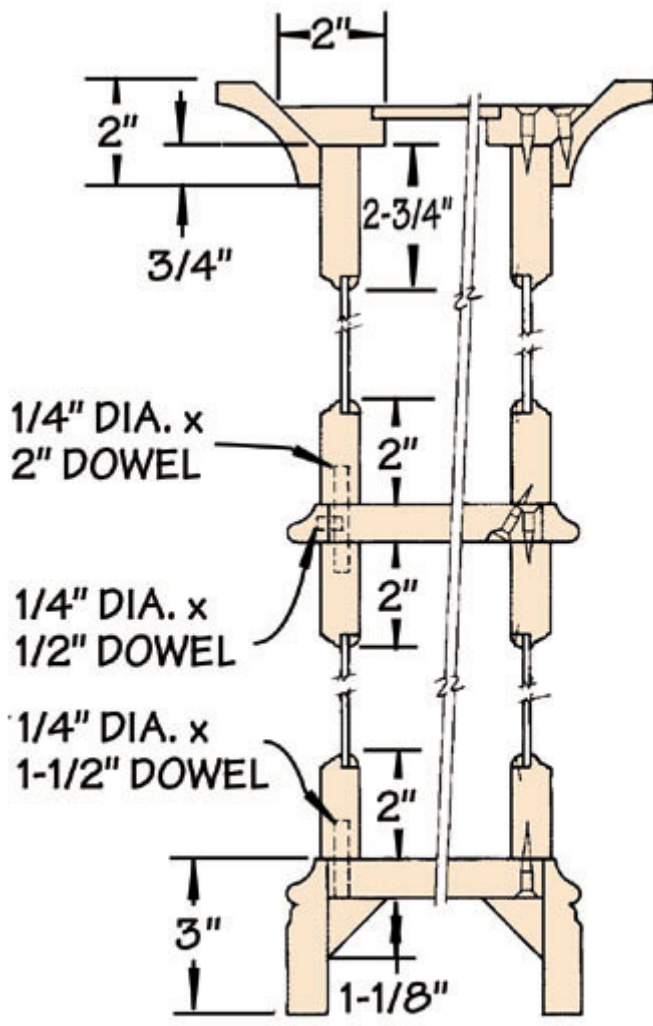

CONSTRUCTION DETAIL

#5 x 1/2" SCREW

1/4" WASHER

1/4" DIA. x 1-1/2" LG
DOWEL

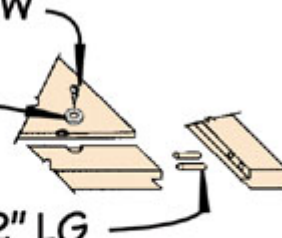

CORNER DETAIL

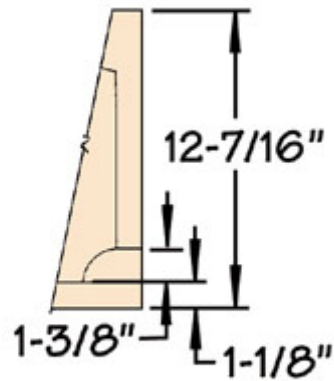

DOOR PANEL LAYOUT

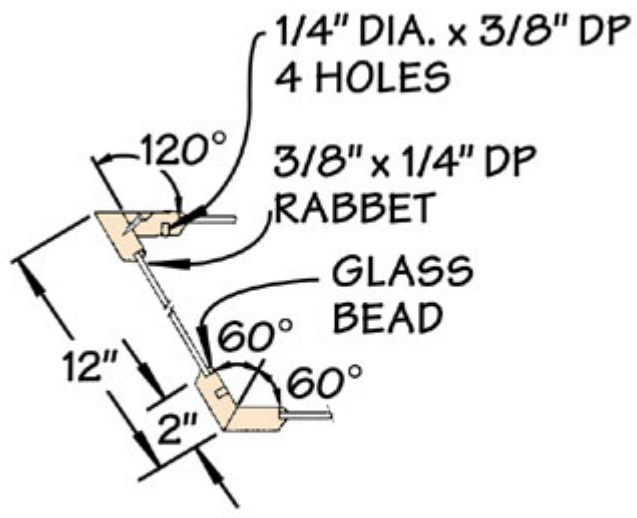

SECTION A-A

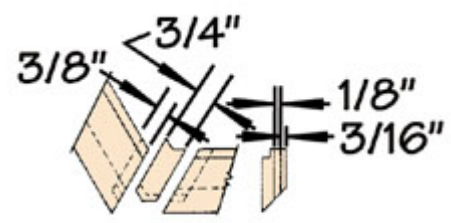
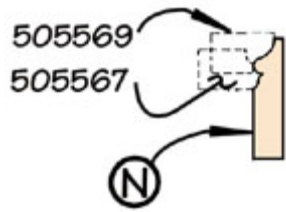
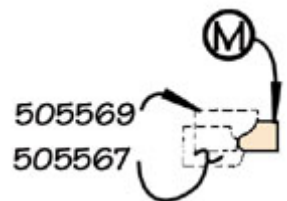

SPLINE DETAIL

POT HOLDING GARDEN PLANTER

A Lightweight, Easy-To-Move Planter For Your Deck Or Patio



Made to hold 10-inch or 12-inch clay pots, this planter lets you remove your plants for easy re-location or switch from plant-to-plant without digging or making a mess !

Looking to dress up your deck, patio or front porch with some greenery, but don't want to hire a landscape designer or pay the hefty retail prices stores want for wooden planters?

This handsome redwood planter (or even a few of them) is just what you've been wanting. PLUS -- Since your plants will be growing in your choice of 10-inch or 12-inch clay pots, suspended from the top of the planter, (you can alter the dimensions to hold much larger pots, if you like), you can remove your plants and move the lightweight planters from location to location without soiling your deck . . . or change the plants you have on display without having to re-pot them.

Step 1: Buy your pots. It's best to purchase the pots you're planning to use before you start work. Measure the height and outside diameter of the pot's lip, at the top. You'll be using these dimensions frequently once you get started on construction. We recommend that you purchase natural, un-



glazed terra cotta pots, since they allow the roots of your plants to “breathe” efficiently.

At the lumberyard: The dimensions included in this plan are for a 10-inch or 12-inch pot, but you can make a planter to hold any size pot you like. You'll just have to adjust your other planter dimensions accordingly. For our planter, you'll need two 8-foot 2 x 4's, one 4-foot 1 x 10 and four 8-foot 1 x 4's (for a 10-inch pot). If you're planning to use a 12-inch pot, you'll need four 8-foot 1 x 6's instead of 1 x 4's.

We made our planter out of redwood. But Western Red Cedar or Cypress are a couple of other great choices, since they're also well suited to outdoors use. You'll also need to buy the hardware listed in the Bill of Materials.

Step 2: Making top and bottom frames. Start by crosscutting the 2 x 4's into eight pieces for the top frame (X) and the bottom frame (Y). The lengths of the four “B” boards (two for the top frame X and two for the bottom frame Y -- See Frame Sides Detail) are determined by adding 3-1/2-inches to the outside diameter of the pot's mouth). The lengths of the four “A” boards (two for the top frame X and two for the bottom frame Y -- See Frame Sides Detail) are determined by adding 1-1/2-inches to the outside diameter of the pot's mouth.

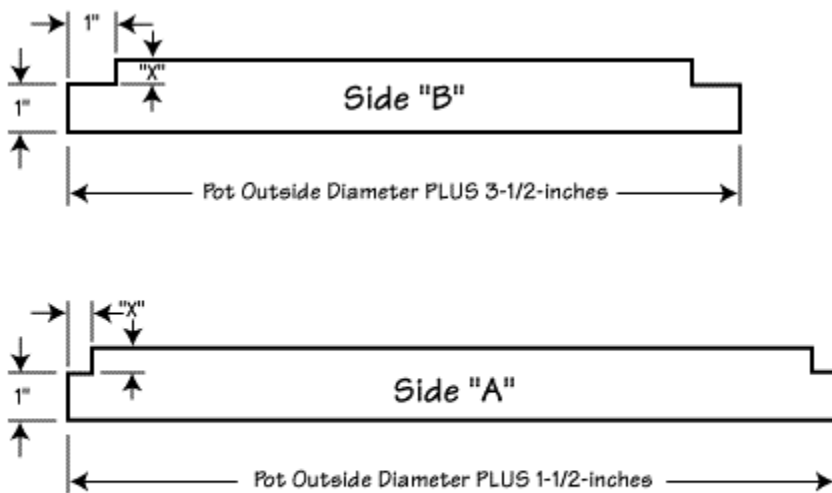

"X" Dimension = Actual Board Thickness Minus 1"
(Approximately 1/2" for standard 2 x 4)

Next, use a router or table saw to cut the rabbets into the ends of the (A & B) pieces as shown by the Corner Detail drawing. The depths of your cuts should be equal to your board's actual thickness minus 1-inch (See Frame Sides Detail).

Step 3: Cutting the sides, top support and cover. If you're making a planter for a 10-inch pot, rip your 1 x 4's (side pieces - C) to a width of 3-5/16-inches. If you're using a 12" pot, rip your 1 x 6's (side pieces - C) to a width of 3-3/4". These ripped boards will be used to make the planter sides (C) and pot support (D).

To make the sides (C), crosscut your ripped boards into 16 identical pieces that are equal to the overall height of your pot plus 4-3/4-inches. For the pot support (D), cut two pieces that are equal to the outside diameter of the pot's mouth plus 3-1/2-inches.

To make the potholder top, crosscut two 1 x 10 pieces to a length that's equal to the outside diameter of your pot's mouth plus 3-1/2-inches. Now, find the center point of each piece at its very edge (See Top Cut-Out Detail). This center point will mark the outer edge of your semi-circle. To calculate the radius of the semi-circle you'll be cutting, subtract 1-inch from the outside diameter of your pot's mouth and divide that figure by two. Draw a semi-circle of that radius on each of your two top pieces and use your band saw, scroll saw or sabre saw to cut out the centers of each board.

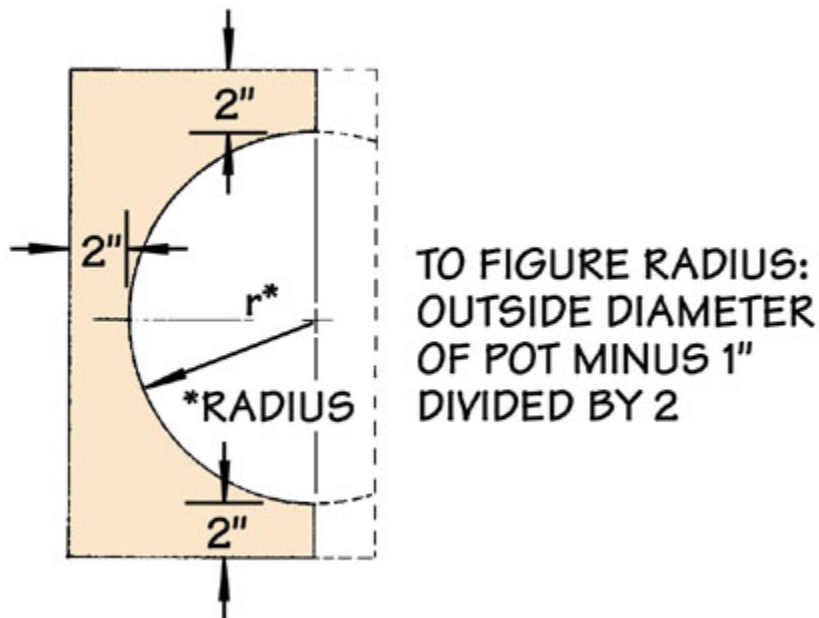

Once you've cut out the centers, cut off the two open edges of each board so its width is one-half its height (See Top Cut-Out Detail)

Step 4: Assembly. To assemble the top frame (X) and the bottom frame (Y), drill two pilot holes (above one another) at each of the corners where

the "B" and "A" frame sides meet (See Corner Detail) and screw them together.

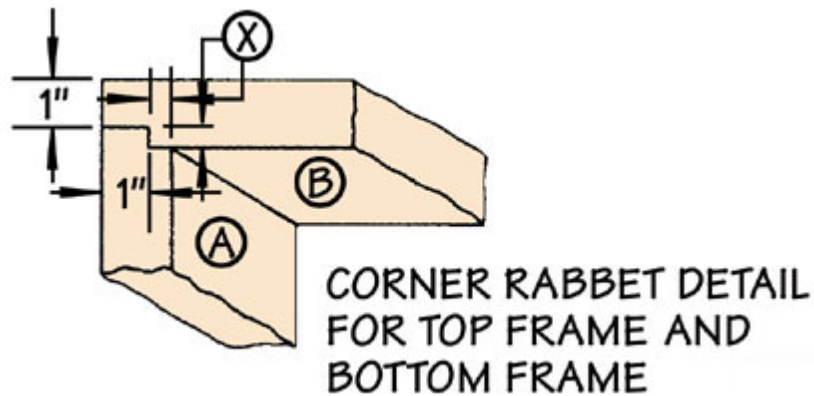

Next, drill two small nail pilot holes in each end of the two pot supports (D) and nail them in an approximate centered position to the "A" pieces of the bottom frame (Y), leaving a 1-inch gap between the boards.

Sand the rough edges of the side pieces (C) and cover (E). Drill four small nail pilot holes in each side piece (C). Position them with two holes 3" down from the top and two more holes 1-1/2-inches up from the bottom of each piece.

Nail the side pieces (C) onto the top frame (X) and bottom frame (Y) so that the bottom of each piece is 1" up from the bottom of the bottom frame (Y), and 1-1/4-inches above the top of the top frame (X). Space the sides (C) evenly, leaving a slight gap at each end, as well as even gaps between each piece. For the best fit, rasp or sand the cover pieces (E).

Ideally, your pot should be supported on its bottom and not by its lip. For that reason (and since pot dimensions will vary), you may have to lay small scrap blocks across the two pot supports (D) to raise your pot slightly in the planter so it is not supported by its lip.

Step 5: Finish the planter. Although all of the recommended woods are highly durable when used outdoors, you might wish to finish your planter(s) with a transparent, penetrating oil stain, formulated for exterior use.

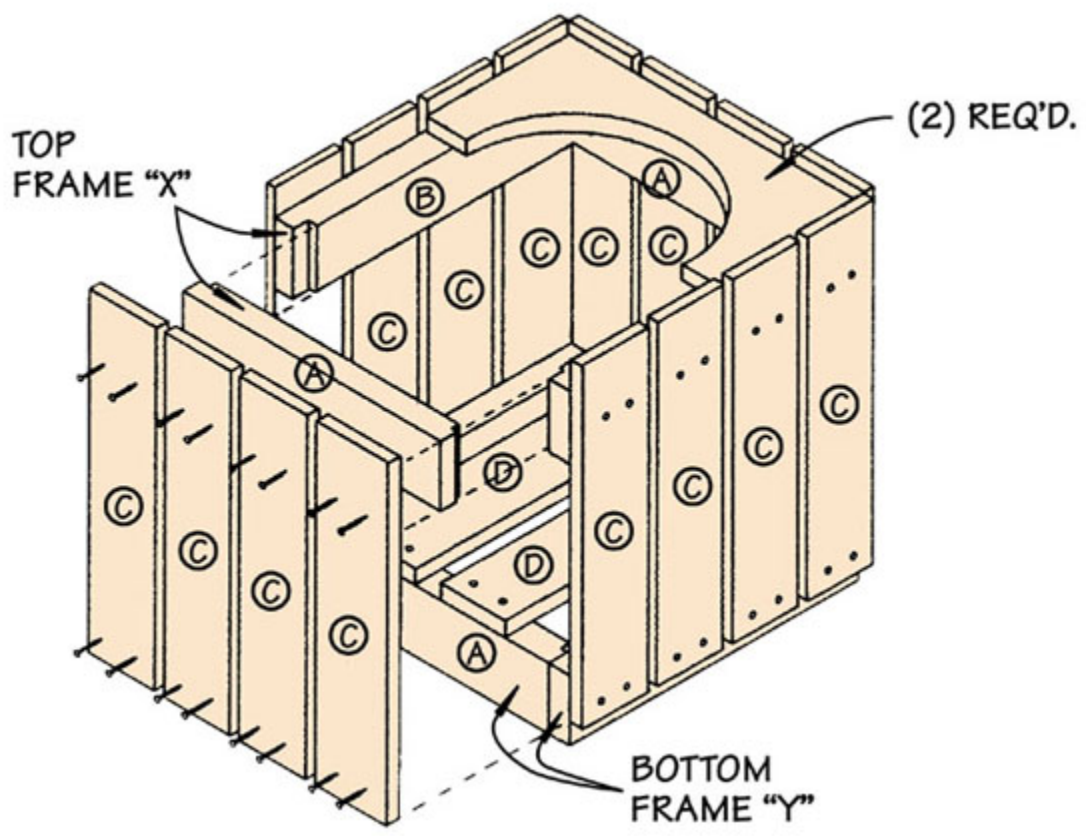



List of Materials

(finished dimensions in inches)

Garden Pot Dimensions*

	10-Inch Pot	12-Inch Pot
Outside Diameter – Pot Mouth	10-1/8	12-1/4
Pot Height	13-1/2	14-1/4
Cover Radius	4-9/16	5-5/8

Component Dimensions

A Frame Sides (4)	1-1/2 x 3-1/4 x 11-5/8	1-1/2 x 3-1/4 x 13-3/4
B Frame Sides (4)	1-1/2 x 3-1/4 x 13-5/8	1-1/2 x 3-1/4 x 15-3/4
C Side Pieces (16)	3/4 x 3-1/4 x 18-1/4	3/4 x 3-1/4 x 19
D Pot Supports (2)	3/4 x 3-1/4 x 13-5/8	3/4 x 3-1/4 x 15-3/4
E Cover Inserts (2)	3/4 x 9-1/8 x 18-1/4	3/4 x 9-1/2 x 19

Hardware

#12 x 2-1/2 Flathead Wood Screws (Stainless or Brass)	16
6d Galvanized Nails	1/2 pound

***NOTE:** All dimensions are based on two, standard, red clay, terra cotta pots purchased at a local nursery supply house. These pots have the mouth diameters and pot heights indicated here. If the dimensions of your pots vary significantly from these, the dimensions for your workpieces will have to vary accordingly, based on the instructions.

BUTCHER BLOCK/MICROWAVE OVEN TABLE



Just a generation or so ago, butcher blocks were as common in kitchens as ice boxes and wood-fired stoves. But, in the 40's, 50's and 60's, modern kitchens started to get smaller. Out of necessity, these big, bulky blocks were replaced by space-saving, countertop cutting boards. And although today's newer homes seem to be getting larger and larger (many have kitchens with enough space to park the family sport utility vehicle), there are still a lot of folks living in older homes with limited space. If this describes your kitchen, this special Table is for you.

The simple design of this Table returns the classic butcher block to the kitchen...and gives today's most common, high-tech appliance -- the microwave oven -- a convenient, out-of-the-way place of its own. Or, if you prefer, you can build your table with our "storage option" which includes a slide-out drawer and "cubbyholes" for cookbooks, dishes, small appliances, etc.

Add casters to create a convenient, portable cutting surface, extra counter space or even a roll-around patio barbecue cart. Double or triple the size of the top and add an extra set of center support legs to turn it into a garden cart or even an extra workbench for the shop. The modifications and applications are limited only by your imagination.

GETTING STARTED

The lumber requirements for the project as shown here include 11'-6" of 2" x 2" stock, 27 board feet of 3/4" thick stock and another 27 board feet of 1/4" thick plywood. If you've decided to make the storage unit that sits in the microwave area on the lower shelf, you'll also need a half-sheet of 1/2" thick



plywood. Start by cutting all your stock to size. The 2x2's (actually 1-3/4" x 1-3/4") should be cut to exact length, while all the 3/4" stock should be cut 1/16" over actual width, then jointed to their exact width. The stock for the sides and back of the drawer should be resawed on the bandsaw, then jointed or planed to the final 1/2" thickness. With the stock at its finished thickness and width, all the pieces should be crosscut to their finished length.

NOTE: Since all microwave ovens are not the same size, be sure to measure your oven, check it against the measurements included here and alter the sizes of any pieces as required to accommodate the oven.

THE LEG & RAIL ASSEMBLY

Before cutting the legs (A), decide whether or not you want to add casters to make your Table mobile. If so, be sure to make the legs 2" shorter than called for in the plans or your table will be too high...then drill a hole in the bottom of each leg to receive the caster shaft or its drive-in, metal "receiver".

Next, drill and counterbore the holes in the legs (A) for the screw shanks where the top & bottom side rails (B,C)...top & bottom front and back rails (E,F)...and shelf (G) attach to them. NOTE: If you're making the stand to hold a microwave oven, be sure to position the lower shelf (G) 4" lower than indicated in the plan to accommodate the height of the oven. Again, be sure to measure your oven before deciding where to position the shelf.

If you're making the table with a lower storage unit instead, be sure to attach the two drawer guide strips (D) to the top side rails (B) with counter-bored wood screws before putting the two leg assemblies together. See the drawer guide detail drawing.

Use a 1/8" drill to bore screw pilot holes in the ends of all rails (B,C,E,F) and assemble the side rails (B,C) to the legs (A) using 1-3/4" #8 flathead wood screws (Y). Cover the screw heads with dowel buttons or plugs (Z).

THE BASE ASSEMBLY

Put the base assembly together by connecting the two leg & rail assemblies with the top back (E) and bottom front & back (E) rails, using 1-3/4" #8 flathead wood screws. As before, cover the screw heads with glue-in dowel buttons or plugs.

Build the shelf (G) by gluing individual pieces of 3/4" stock edge-to-edge to create a piece that's 22" x 27-3/4". Once the glue has dried, hand sand or



belt sand the shelf to a smooth surface, then notch-out the corners of the shelf to fit snugly inside your legs, resting on top of the lower side (C) and lower front and back (E) rails. Position the shelf (G) on top of these rails (C,F) and use a 1/8" bit to drill the screw pilot holes in the edges of the shelf (G).

THE DRAWER

The drawer slides in and out on two guides (D) that fit into mating grooves on the drawer sides (K). Use a dado blade setup to cut a 3/16" deep x 3/4" wide groove in each drawer side (K), as shown in the drawer drawing. These grooves will slip over the drawer guides.

Cut the remaining joinery in the various drawer components as shown in the drawing. Use your Shopsmith Router or Dado setup to form a 1/2" deep x 1/2" wide vertical rabbet in each end of the drawer front (H) -- and a 1/4" deep x 1/2" wide vertical dado in each drawer side (K) to accept the drawer back (J). Then cut a 1/4" wide x 1/4" deep groove all the way around the bottom insides of the drawer sides (K), front (H) and back (J) to accept the 1/4" plywood drawer bottom (L).

Drill and countersink holes in the drawer sides (K) for attaching the front and back, as shown. Drill a screw hole in the drawer front (H) for the drawer pull (AA). Assemble the drawer pieces with glue and 1-1/4" #6 flathead wood screws (X).

NOTE: Do not glue the bottom in place.

THE KNIFE BLOCK

The knife slots in the knife block (M) are formed by cutting corresponding grooves in the two mating knife block pieces prior to assembly. We have provided some example sizes for the groove widths and overall size of the block. However, we recommend that you measure the widths of the knives you plan to slip into the block and adjust the groove widths as well as the overall size of your knife block to accommodate your knives. Cut each groove to a depth of 1/8", giving you a 1/4" wide slot, then glue the two pieces face-to-face with the grooves aligned. Mount the knife block to one of the side rails (B) with a 5/8" thick spacer block (N) to compensate for the rail set-back.

THE BUTCHER BLOCK TOP

The top (P) is reinforced and its individual pieces aligned with threaded metal rods (S). After cutting the appropriate number of top pieces (P), use your



drill press to bore a series of mating holes in each to accept your 3/8" threaded rods (S). See [Fig. 1](#).

IMPORTANT: Use a 1" diameter bit to drill larger holes in the two outer-most pieces of your butcher block. These holes will fit over the nuts (U) and washers (T) that are used on each end of your threaded rods.

Assemble the top pieces using waterproof carpenter's glue, epoxy or two-part resorcinol glue. Be sure the pieces are aligned properly before tightening the threaded rods to pull everything together. Be careful not to over-tighten, as this could starve the glue joints. Next, drill and counterbore the screw holes, as well as the holes for the 1" diameter dowel handle in the two top facings (Q). Attach the facings to the assembled butcher block top (P) with 1-1/4" #6 flathead wood screws (X). Use dowel plugs or buttons (W) to cover the screw heads. Using a belt sander, smooth the butcher block top (P) and top facings (Q). Glue the handle (R) into position.

FINAL ASSEMBLY

Transfer the screw holes in the edge of the rails (B) to the bottom of the butcher block top (P). Drill the screw holes, but wait to assemble the butcher block to the side rails until after you have finished the stand to match the décor of your kitchen. Be sure to use a non-toxic [salad bowl finish](#), [non-toxic oil finish](#), or Beeswax Salad Bowl Finish on the butcher block top. The remainder of the stand can be finished with any grease and water resistant finish such as polyurethane or lacquer.

Finally, using 1-3/4" #8 flathead wood screws (Y), assemble the butcher block top (P) and two facings (Q) to the rails (B).

THE OPTIONAL STORAGE UNIT

If you're not planning to use the lower shelf to hold a microwave oven, you can make good use of the space with this optional storage unit.

From a piece of 1/2" thick plywood,, cut all pieces to size, according to the [Bill of Materials](#). Use your dado set-up to cut the joinery, as shown in the storage unit drawings. Sand all pieces smooth and assemble them using glue and 1" #18 wire brads (BB). Use nailset to countersink the brad head, then fill them with wood putty that matches the finish you're planning to use. Cover the edges of the plywood with veneer tape or thin, solid wood strips and finish the storage unit to match the remainder of the table.



LIST OF MATERIALS

(finished dimensions in inches)

A	Leg (4)	1-3/4 x 1-3/4 x 34
B	Upper end rail (2)	3/4 x 4 x 18-3/4
C	Lower end rail (2)	3/4 x 2-1/2 x 18-3/4
D	Drawer guide (2)	5/8 x 3/4 x 19-1/2
E	Upper back rail	3/4 x 4 x 24-3/4
F	Lower back rail & front rail (2)	3/4 x 2-1/2 x 24-3/4
G	Shelf	3/4 x 22 x 27-3/4
H	Drawer front	3/4 x 4 x 24-5/8
J	Drawer back	1/2 x 3-1/2 x 24-1/8
K	Drawer sides (2)	1/2 x 3-1/2 x 18
L	Drawer bottom	1/4 x 17-1/2 x 24-1/8 (plywood)
M	Knife block (2)	3/4 x 6 x 9
N	Knife block Spacer	5/8 x 5 x 4
P	Butcher block top pieces (28)	3/4 x 2 x 28-1/2
Q	Top facing (2)	3/4 x 2 x 32-1/2
R	Handle dowel	1 dia. x 22-1/2 long

HARDWARE

S	Threaded rods (4)	3/8 dia. (16 pitch) x 21 long
T	Washers (8)	3/8 I.D.
U	Nuts (8)	3/8 - 16 pitch
V	Flathead wood screws (36)	1-1/2 x #8
W	Dowel plugs (20)	3/8 dia.
X	Flathead wood screws (14)	1-1/4 x #6
Y	Flathead wood screws (32)	1-3/4 x #8
Z	Dowel buttons (32)	3/8 dia.
AA	Drawer pull	

OPTIONAL STORAGE UNIT

BB	Wire brads (1 oz)	1 - #18
CC	Top & bottom (2)	1/2 x 16-3/4 x 23-1/2 (plywood)
DD	Sides (2)	1/2 x 11-1/2 x 17 (plywood)
EE	Back	1/2 x 11-1/2 x 23-1/2

		(plywood)
FF	Vertical divider	1/2 x 7 x 16-3/4 (plywood)
GG	Veneer tape (3)	1/2 x 23
HH	Veneer tape (2)	1/2 x 11-1/2
JJ	Veneer tape (2)	1/2 x 17
KK	Veneer tape	1/2 x 7

Table Assembly

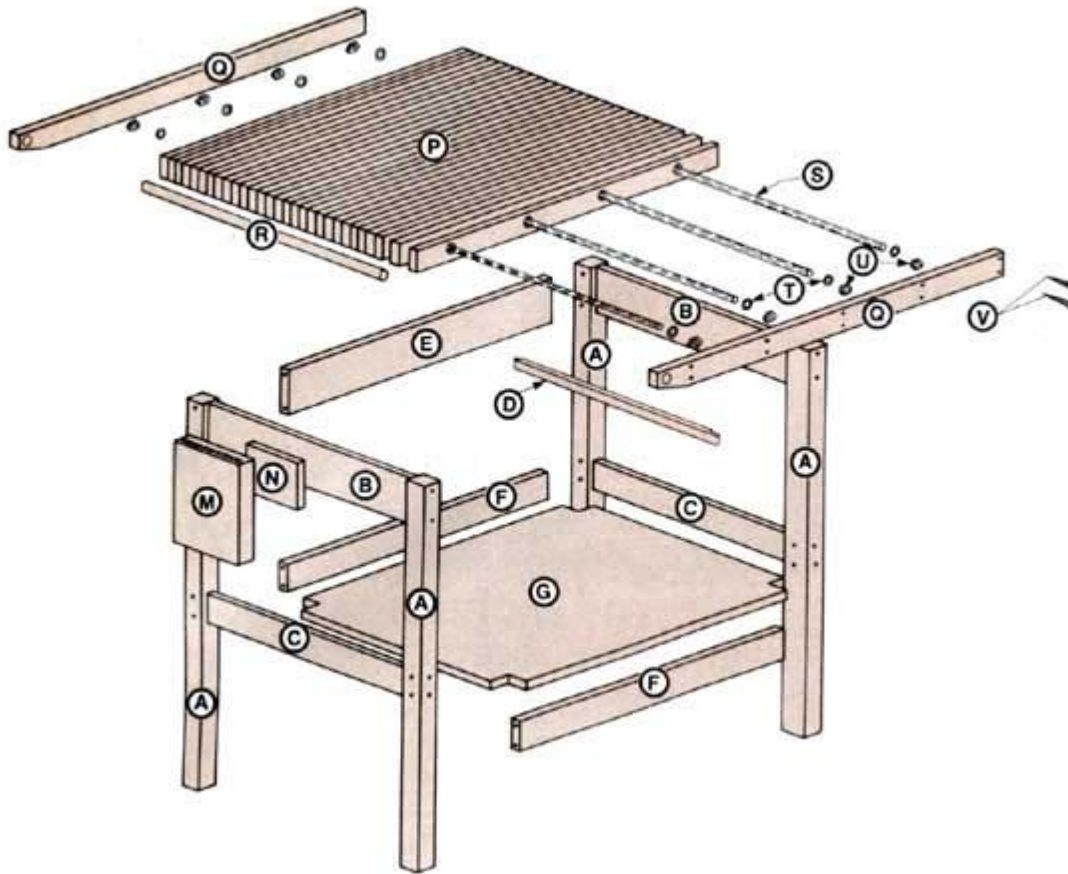

Leg and Rail Assembly

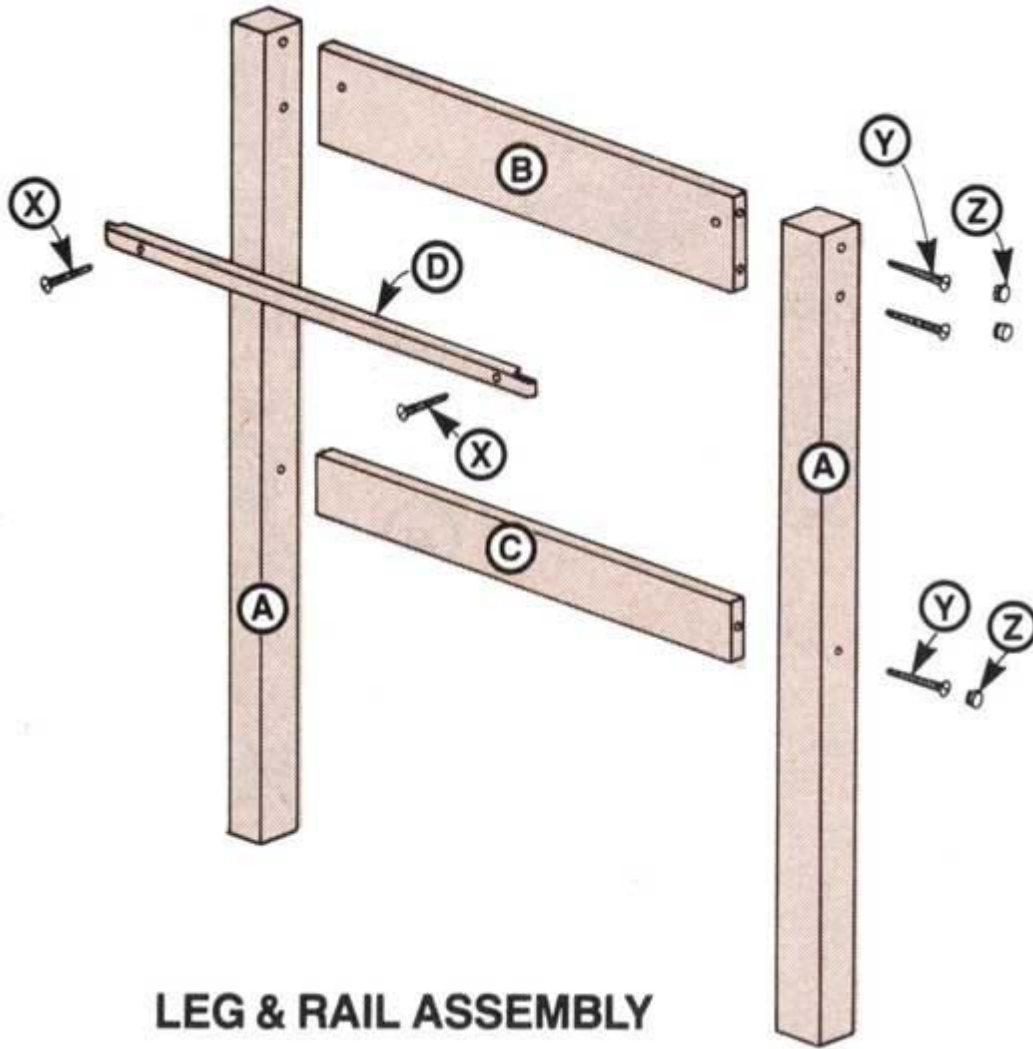

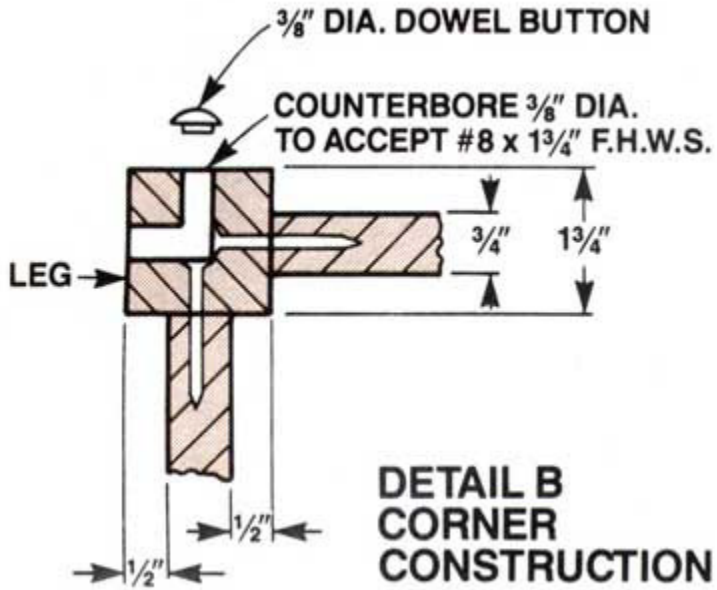

Base Assembly

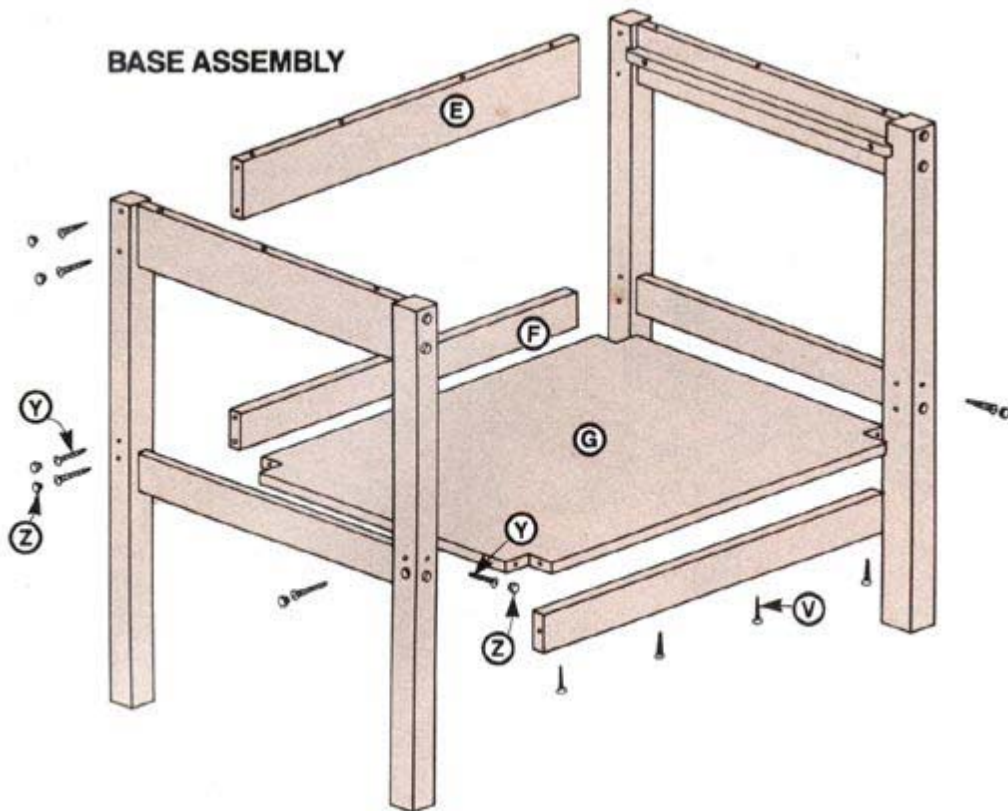

Drawer Assembly

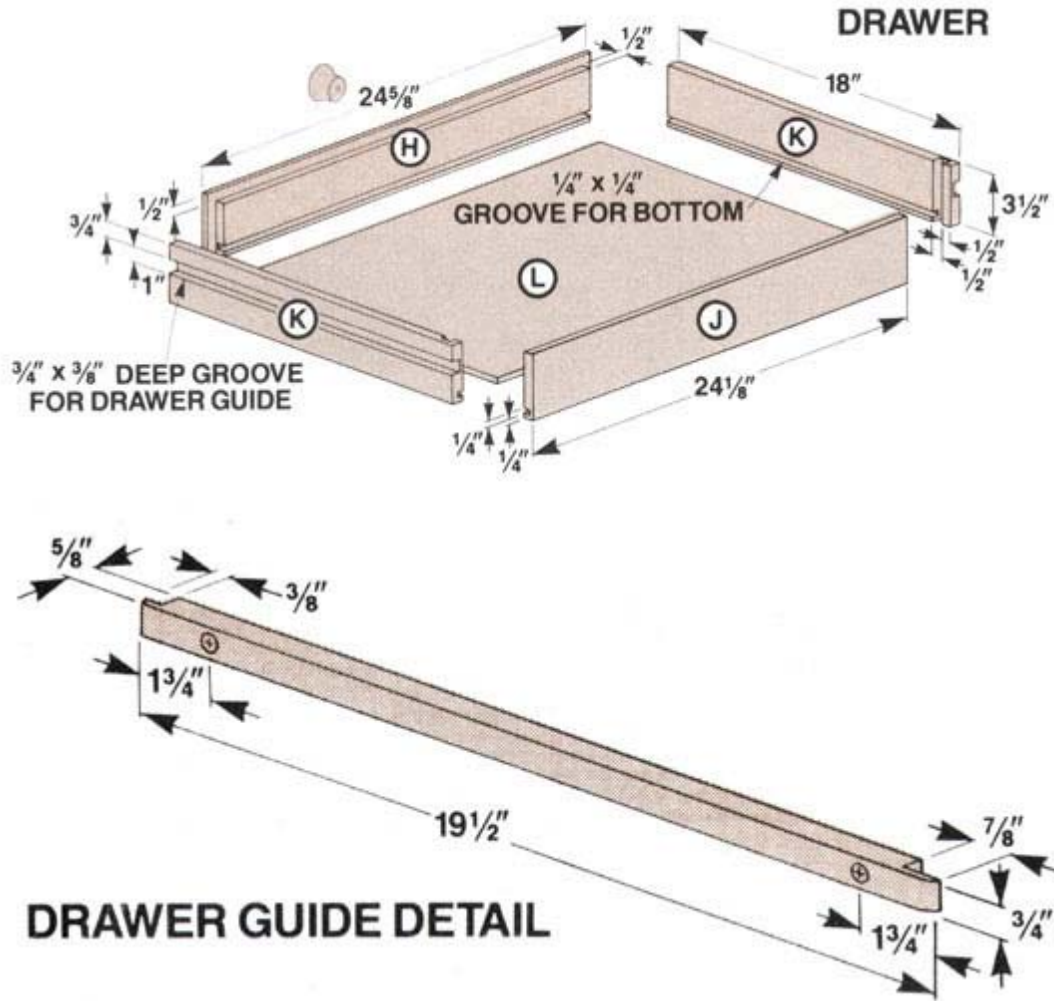

Drawer and Knife Block Assembly

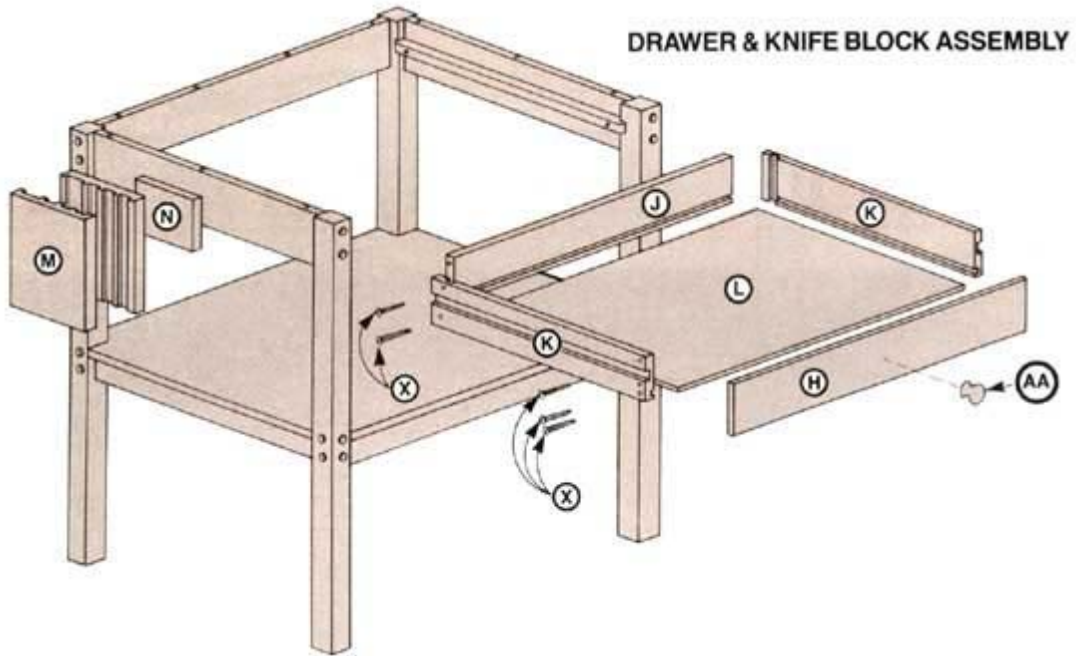

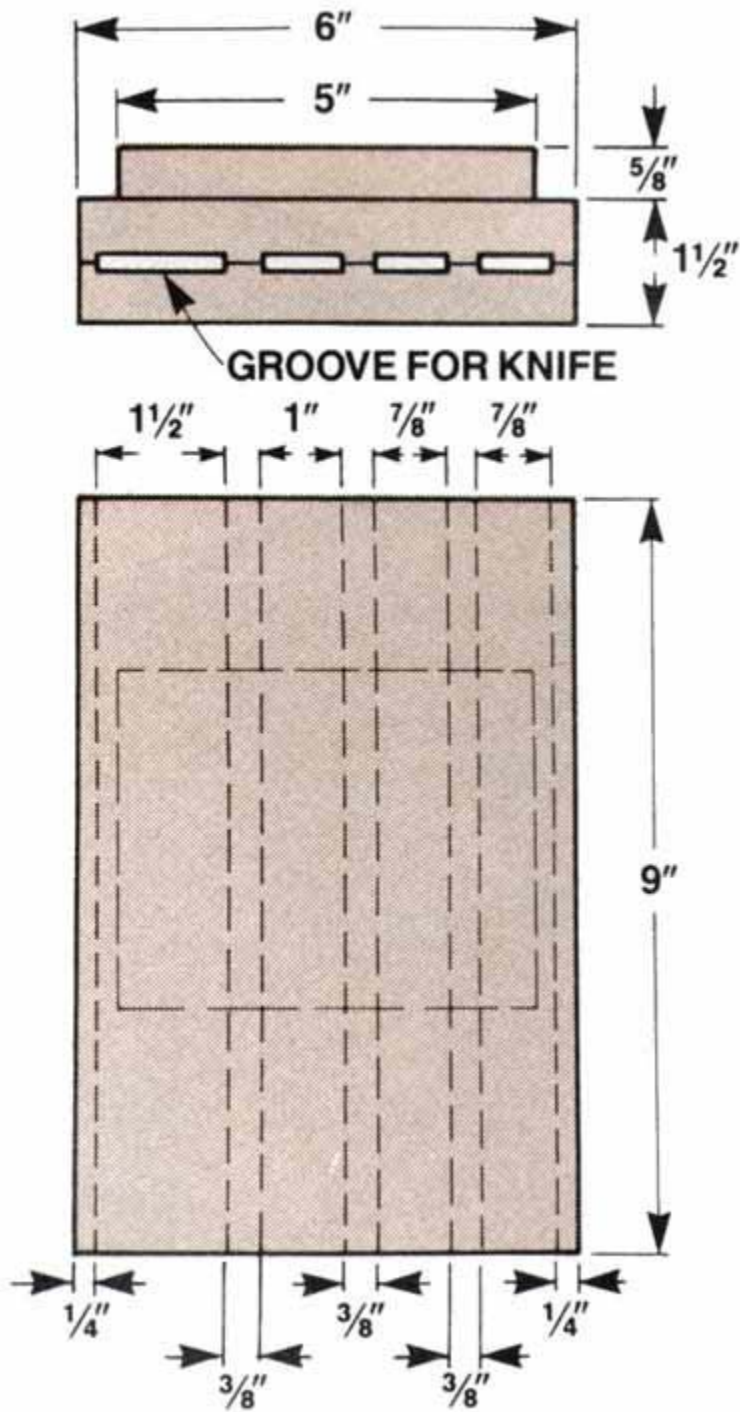

Butcher Block Top Assembly

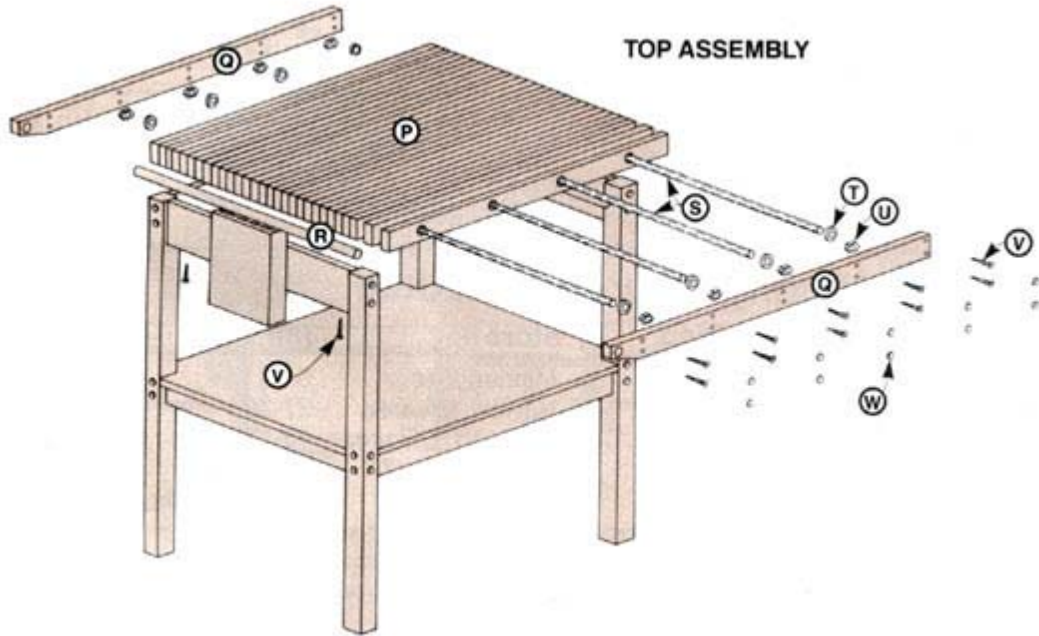
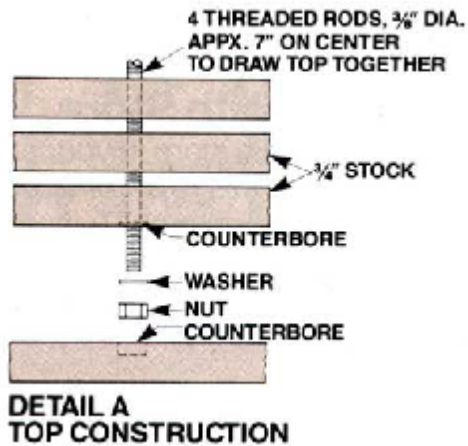
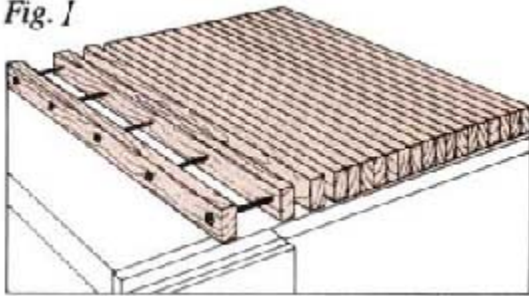
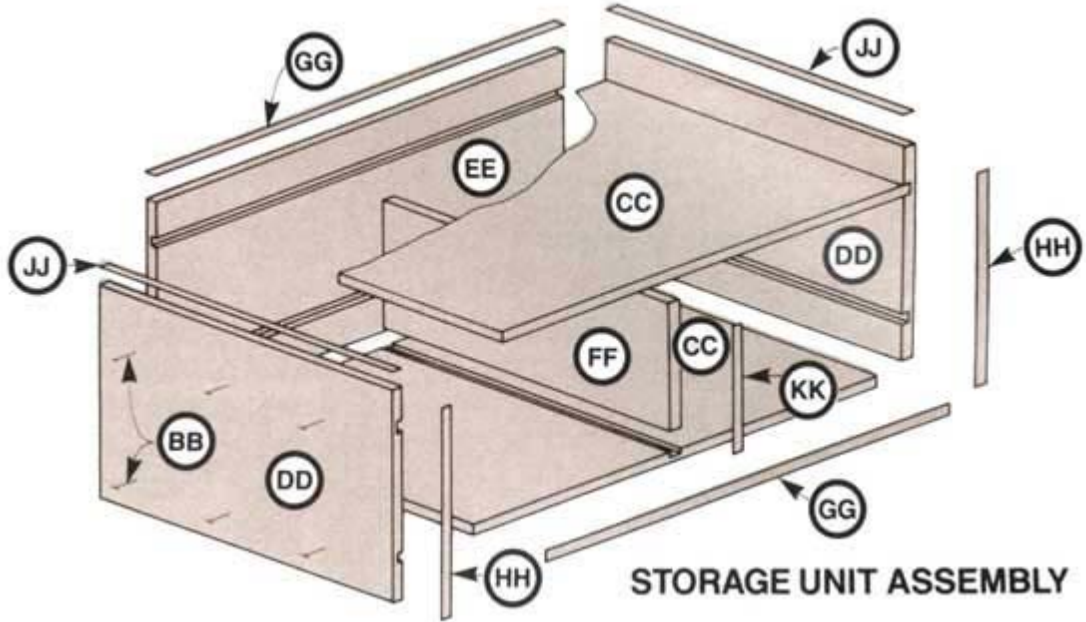

Fig. 1



Storage Unit Assembly



ASSEMBLE WITH 1" - #18 BRADS

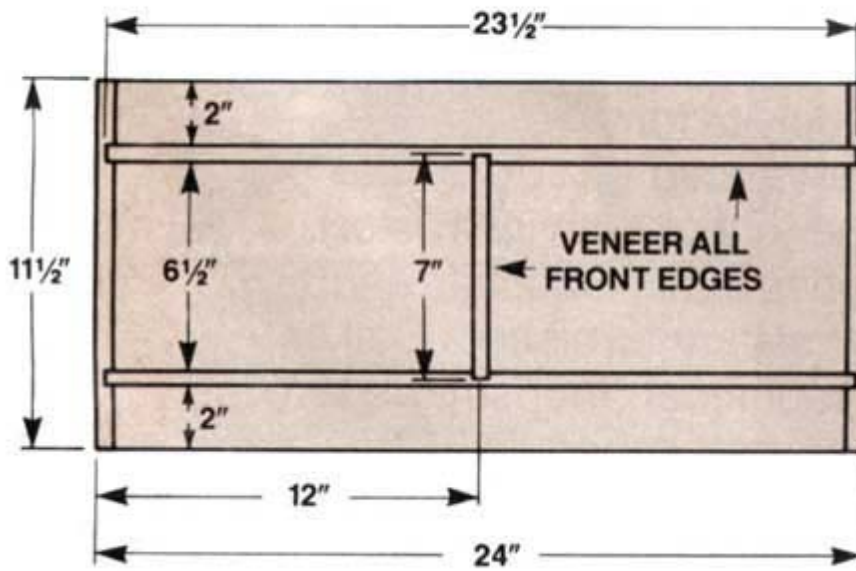

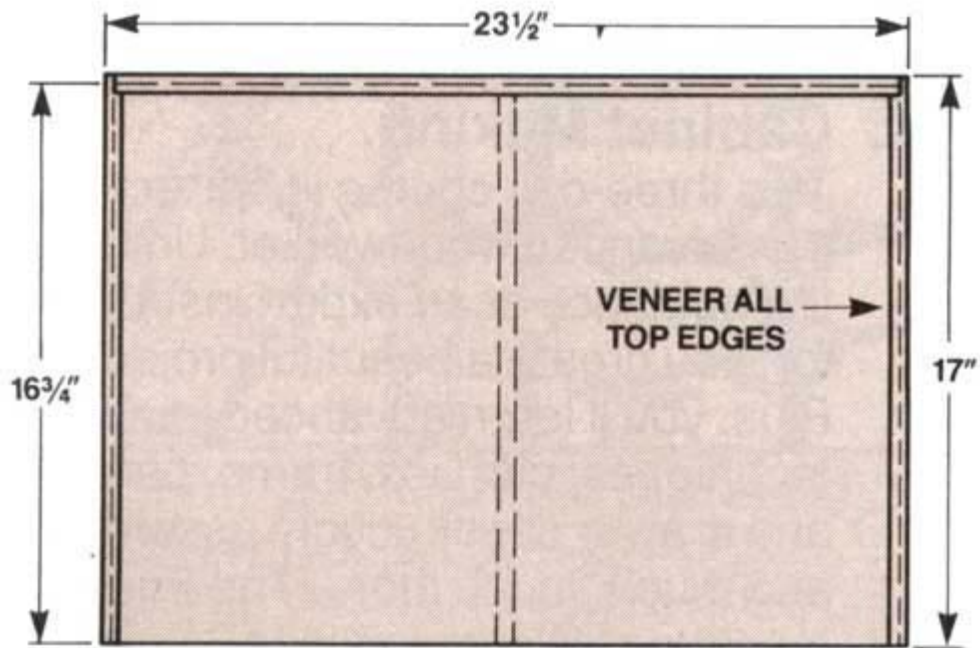

STORAGE UNIT (OPTIONAL)

Stand Layout

STAND LAYOUT

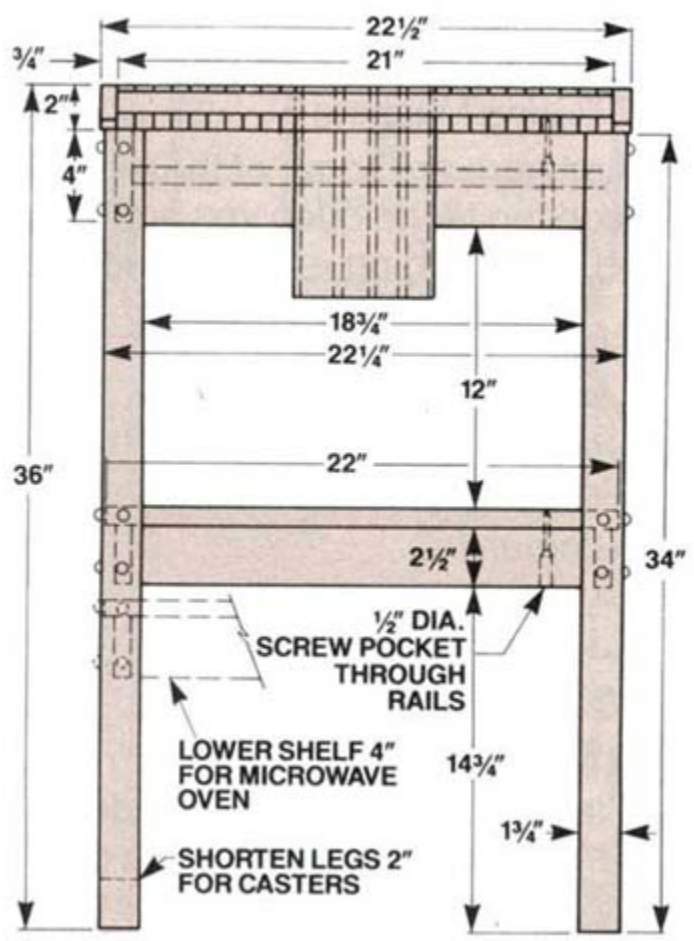

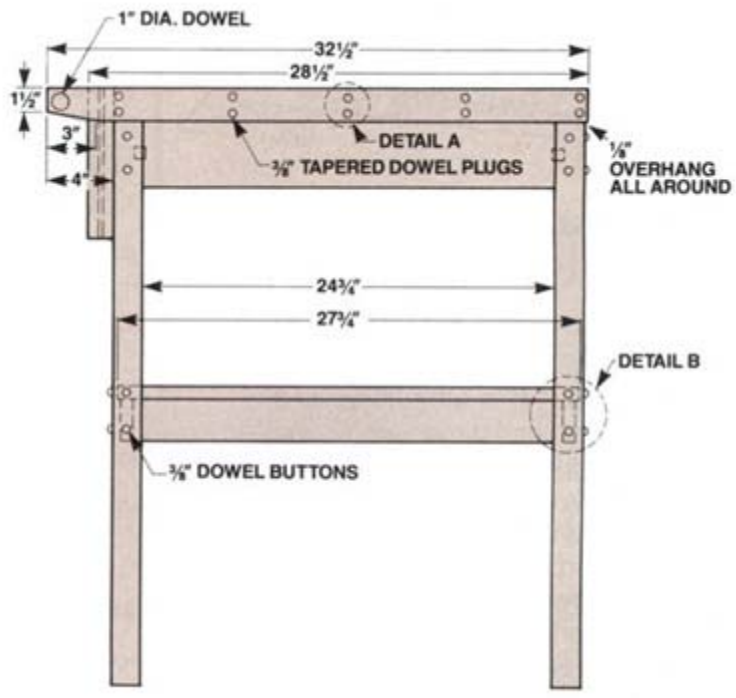

INTERLOCKING LOGS

An easy-to-build project with strong appeal to craft show buyers and Holiday gift recipients alike.



We started with 1" X 4" X 4' stock that actually measured 3/4" x 3-1/2" x 4'. Lay out the logs for crosscutting and notching according to the plans.

CAUTION: It's best to start by cutting your dado notches across wider pieces of stock, then ripping the logs off to the 3/4" x 3/4" dimension since short, narrow pieces are difficult to hold while notching and doing so will increase your risk of personal injury. Once you've notched your logs, you can cut the pieces off to the lengths. Use a dado blade set-up to cut the 3/4" wide x 3/16" deep connecting notches. Make your dado cuts in one side of the log, then flip it over and make the opposing notches in the other side. A miter gauge indexing fixture will make the job go faster. Don't forget to leave space for your saw kerfs.

Once you've made all your connecting notch cuts, set up your rip fence and rip off your individual logs to their 3/4" widths. Use a pushing device to keep your hands out of harm's way during the ripping process. Next, with a 1/4" & 1/2" Combination Quarter-Round Cutter round-over the edges of your ripped log lengths. Use a feather board for safer handling. Crosscut your logs to length.

Use a band saw to re-saw stock for the 1/8" thick roof planks. While your band saw is set up, re-saw a few different sized logs in half (top-to-bottom). These logs with flat, un-notched bottoms are great for the bases of cabins and similar structures. Next, cut out your roof trusses (different length trusses can be made to match-up with different length logs). These trusses can be made to be the same lengths as some of your logs...or longer to extend out beyond the edges of your structures. Just be sure the lengths of



their angled sides are made to match-up with the widths of your roof planks. Notch a few chimneys to match the angles of your different roof truss tops.

Finally, stain your logs and roof pieces using a mixture of food colors, then apply a non-toxic cover finish such as our salad bowl finish, non-toxic oil finish, or Beeswax Salad Bowl Finish.

Bill of Materials...

1-notch log	3/4 x 3/4 / 1-1/2
2-notch log	3/4 x 3/4 / 4-1/2
3-notch log	3/4 x 3/4 / 7-1/2
4-notch log	3/4 x 3/4 / 10-1/2
5-notch log	3/4 x 3/4 / 13-1/2
6-notch log	3/4 x 3/4 / 16-1/2
Other lengths	add 3" per notch
Roof Trusses	3/4 x 1-3/4 x 6
Chimney	3/4 x 1-3/8 x 1-3/8
Roof Slats	1/8 x 3/4 x (variable lengths)

For generations, children have enjoyed playing with interlocking logs to build log cabins, barns, fences and similar structures. These simple toys give many children their first taste of how to be creative, while keeping them occupied for hours on end. This simple Interlocking Log project can be built with scrap wood that might otherwise go to waste. We've included drawings for four different sized logs (having one to four notches)...but you can easily make 5-notch, 6-notch or even 8-notch logs and larger roof trusses, if you like for those really big buildings. We used 3/4" poplar for our logs, but any soft wood that doesn't splinter easily such as pine, fir or spruce would work just as well.

Roof and Chimney

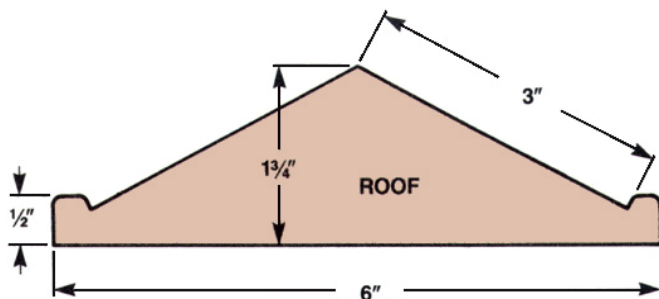

Logs

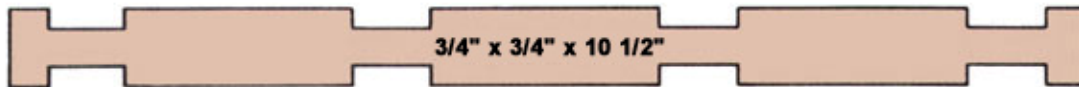
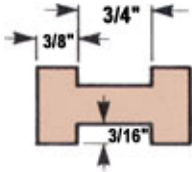

RECIPE BOX-1



Remember the last time you (or the Chief Cook in YOUR house) went looking for a favorite recipe and either couldn't find it...or when you did, it was illegibly smeared with food that you dribbled all over it the last time it was laying on the countertop while you were fixing a meal ? Here's a simple recipe box that will give you 3" x 5" recipe cards a home...with a special saw-kerf card-holder notch in the top to display the recipe you're using and protect it from messy spills. Designed to sit on the countertop or hang on the wall it's quick and easy to make...and practical as it can be.

Start by resawing your stock to the required 3/8" and 1/8" thicknesses with your bandsaw, then smoothing the pieces with your thickness planer, belt sander or jointer. Next, rip all the stock to the required widths and crosscut the various pieces to length, according to the Bill of Materials.

Set your miter gauge to 20 degrees and cut the angled tops of the side pieces (A). Next, set your saw blade to cut a 1/8" wide x 3/16" deep through dado cut, 1/2" up from the bottom of each side (A). Now, tilt your saw table to 20 degrees and bevel the front and back edges of the lid (D), as shown in the drawing. While your table is tilted, adjust your saw blade so it protrudes just 3/16" above the table surface, set your rip fence and cut the card-holding groove in the top surface of the lid (D).



Use your bandsaw or scroll saw to cut the arched contours in the front (C) and back (B), then use your drum sander. Drill the 1/4" diameter hanging hole in the top center of the back (B).

Glue and clamp pieces A, B, C and E together. Cut notches in the back edge of the lid (D) to accept one leaf of the small brass hinges. Apply the finish of your choice. Screw one leaf of each hinge to the lid (D)...then hold the lid in position as you mark and screw the other leaf of each hinge to the back (B).

BILL OF MATERIALS - Recipe Box
(finished dimensions in inches)

A	Sides (2)	3/8 x 3 x 5
B	Back	3/8 x 5-7/8 x 6-1/2
C	Front	3/8 x 5-7/8 x 4
D	Lid	3/8 x 4 x 5-7/8
E	Bottom	1/8 x 3 x 5-1/2

HARDWARE

Hinges	3/4 x 5/8
--------	-----------

Assembly Plans

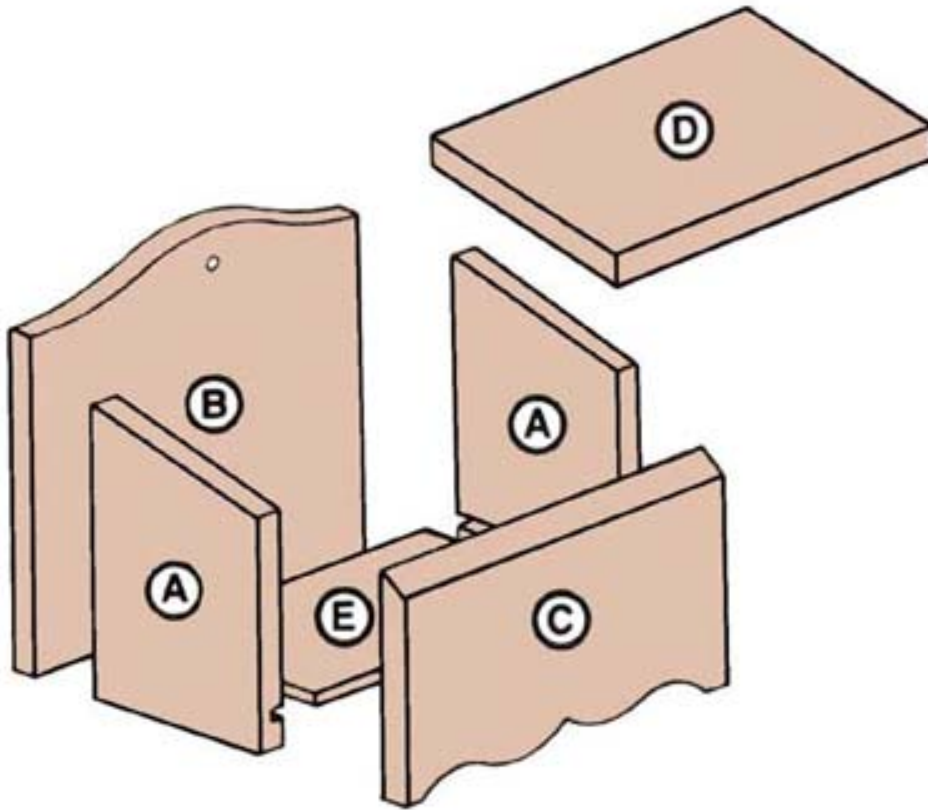

Front View

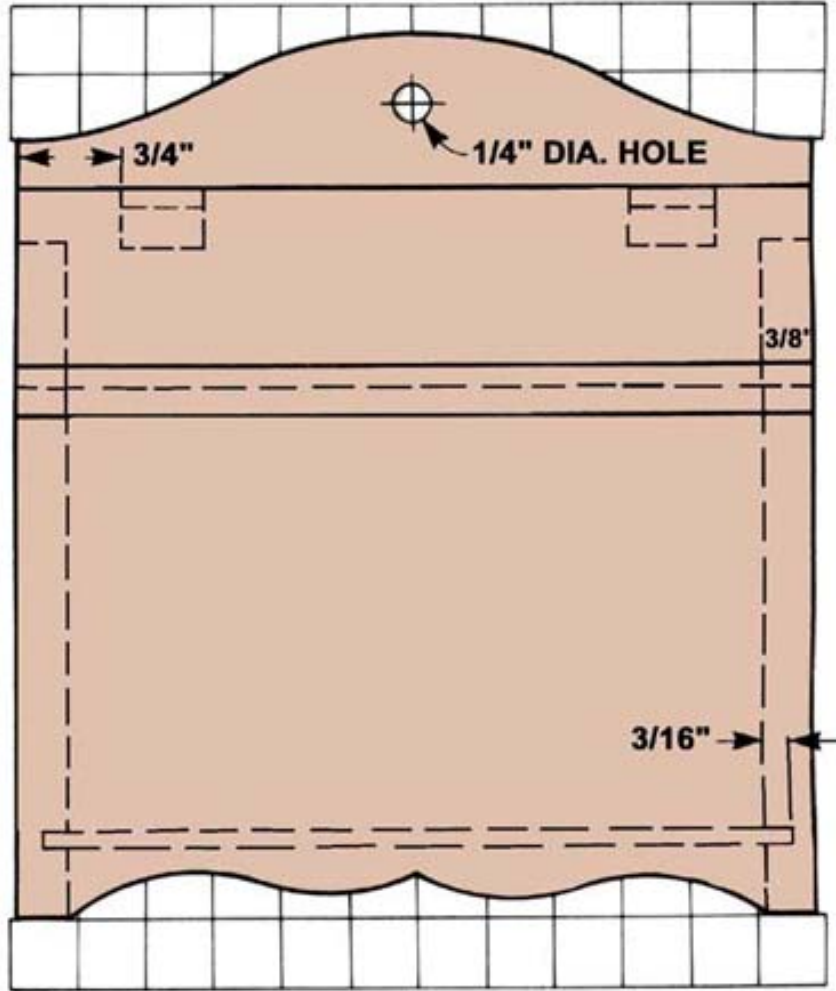

1 SQUARE = 1/2"

Side View

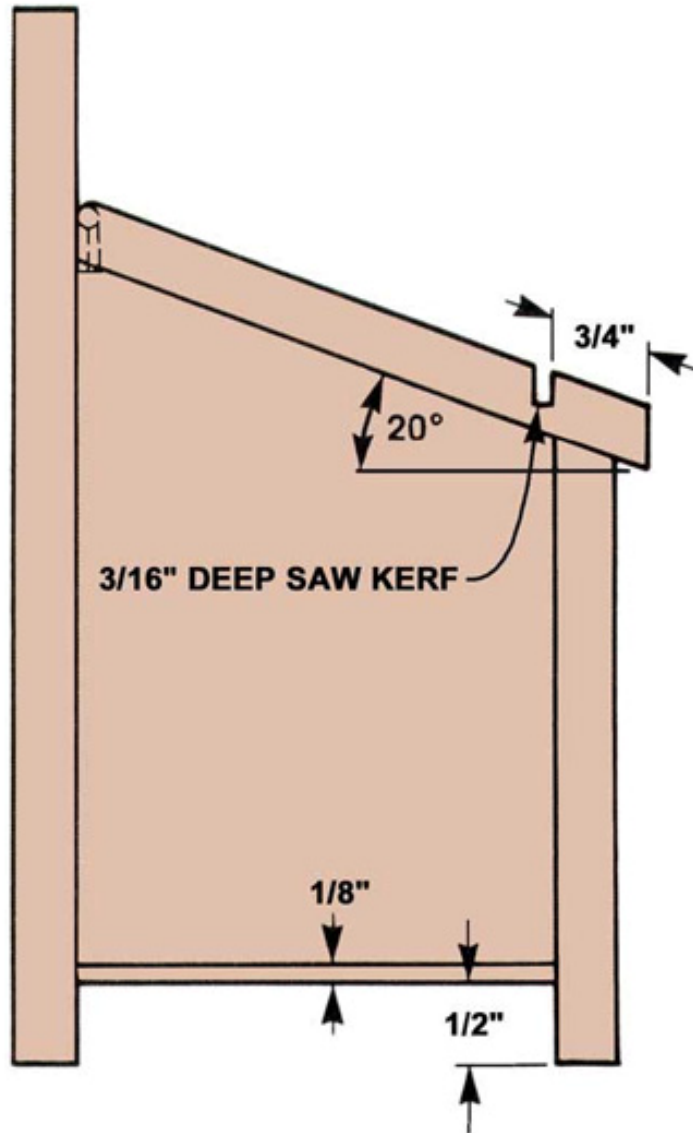

The Colonial Dry Sink

Recalling the earlier days and simpler ways of life -- in Colonial America



In early America, long before the days of shower massages and whirlpool tubs, the dry sink was as commonplace and functional as any fully plumbed sink in a modern, American home. Used with a pottery basin and pitcher, it offered a recessed well on top to prevent the water from splashing out while washing or shaving. And although its original purpose has been made obsolete by modern-day plumbing, there's still a place for this attractive piece of furniture in our homes.

The techniques used to build this project are simple enough, even for beginning woodworkers who are willing to take their time and move step-by-step through the various techniques. There's nothing particularly complicated here. The majority of the components (including the drawer fronts) are assembled with dowels and the raised panel doors feature simple joinery, as well. When you've finished, you'll have a handsome piece of furniture that will make a great addition to virtually any room of the house.

THE FACE FRAME & CARCASE

We built our example out of maple, but clear (or knotty) pine or even cherry would make a beautiful piece, as well. Start by cutting out the stiles and rails (A,B,C,D,E) used in the face frame. Making this assembly first will speed-up the construction of the entire cabinet. Using the horizontal boring mode on your Shopsmith MARK V, drill the required 3/8" dowel holes in the stiles and rails as shown in the carcass assembly drawing. Glue and clamp these



together, being careful to keep them square during assembly. As an alternative (to doweling), these stiles and rails could be assembled using a biscuit joiner and small, #0 biscuits.

Set this assembly aside and glue up the stock for the sides (E), bottom (G) and top (H). As an alternative, you may wish to make the bottom (G) out of veneered plywood. Once they've dried, sand their surfaces smooth. Next, use a dado blade set-up or your jointer to cut the 3/4" wide x 3/8" deep dados in the sides (E) that will be used to hold the bottom (G) in position...then cut the 1/4" x 3/8" rabbets in the backs of the side pieces (E) that will accept the 1/4" plywood cabinet back.

Assemble the completed face frame assembly (A,B,C,D,E), bottom (G) and sides (E) using dowels (as shown) or biscuits. Clamp all pieces and check for squareness. Cut the braces (J) and top cleat strip (K) to length and mount them with #10 x 1-1/2" flathead wood screws. Counterbore the mounting screw holes for the braces (J) so you can plug them later with dowel plugs. Cut the drawer guides (Q,R,S,T) to size and mount these to the carcass with screws and glue.

THE BASE & TOP

To make the base pieces (L,M), start by ripping your stock to 5" widths, then miter the ends (vertically) to a 45-degree angle in preparation for assembly. Be sure to cut your stock a little longer than necessary to allow yourself room for minor adjustments. Remember, you can always use your disc sander to remove a little stock, if necessary...but it's tough (if not almost impossible) to ADD stock to a board that you've cut too short!

Using your bandsaw or scroll saw, cut the curved contours that will form the "feet" of your dry sink. You'll notice that we've made the radius of these curves just slightly greater than the radius of the Shopsmith Drum Sander to ease the sanding process. Shape the top edges of these pieces with a Bead Molding or Shaper cutter...or a 3/8" Round-Over Router bit. Attach the cleat strips (N,P) to the base pieces (L,M), then assemble the base with counterbored screws. Turn the carcass on its back and mount the base assembly (L,M) to it with screws.

Cut the top (H) to size and round over its front and two side edges (do NOT shape the back edge), using the same procedure (and cutters) you used for the top edges of the base. Cut all the required pieces for the splash board (V,W,X) and the splash board shelf (Y). Bevel the bottom edge of the front piece to 20 degrees and cut the angle on the front edges of the side pieces (W) to match. Using your bandsaw or scroll saw, cut the contoured shapes on the four splash board parts (W,X,Y). Using the same procedure (and



cutters) you used for the top edges of the base assembly, shape the front edge of the splash board shelf (Y). Assemble all the parts of this section together with counterbored screws and glue. Attach the splash board assembly to the top (H), using flathead wood screws (screw up from the bottom) and glue. Screw the entire top section (with splash board attached) to the carcass, through the top brace (J) and front cleat strip (K).

THE DOORS & DRAWERS

You're now ready to fit the drawers and doors to the cabinet. Remember that the drawer fronts and doors will be 3/4" wider and 3/4" higher than the openings for them in order to leave a 3/8" lip all the way around their edges. Start by cutting the door stiles (Z) and door rails (AA) to length, according to the Bill of Materials. Be sure to double-check your measurements with your door openings before you make any cuts. With your dado blade set-up, cut the required grooves in the stiles (Z) and rails (AA) that you'll need to put the door frames together. Then cut the tenons on the ends of the rails (AA). A Tenoning Jig will make this job much easier.

Next, tilt your saw table to 15 degrees and cut the bevel for your raised panel doors (BB). **NOTE:** We recommend using a shop-made jig or Shopsmith's Auxiliary Fence to perform this operation more safely. Relieve the back of the door panels by cutting a small rabbet with your dado set as shown in the "Panel to Rail Detail" drawing. This is a "cut-to-fit" operation and you'll want to be sure to use push blocks for optimum safety. Remove just a little of the stock at a time and stop frequently to test the fit of the panel in the grooves. To prevent moisture from finding its way into your raised panels, apply whatever finish you're planning to use to your panels before you assemble them into the frame. Assemble the stiles (Z) and rails (AA) together with glue but **DO NOT** glue the panel into position. Friction will hold it in place quite nicely.

Now, cut the drawer fronts (CC) to size, then cut the rabbets on these and around the edges of the assembled doors. Set your Dado Blade and adjust your fence to make a cut 3/8" deep and 3/8" wide for the rabbets on the back sides of the door rails & stiles...and the top and bottom (back) edges of the drawer fronts. Then, move your fence out 1-1/8" to make the shoulder cuts for the 3/8" deep rabbets on the drawer ENDS. Next, move the fence back to 3/8" and adjust your depth-of-cut to 1-1/8" to make your final pass.

Next, rout a 1/4" wide by 1/4" deep groove in the drawer sides (DD) and fronts (CC) to hold the drawer bottoms (FF). Use your MARK V in the horizontal boring mode to drill the dowel holes in the drawer sides (DD) and fronts (CC). Since there is only a 3/8" clearance here and the dowels are specified to be 1/4" diameter, you'll have little room for error here....so



Measure Twice / Cut Once! Now, drill the dowel holes for the drawer backs (EE) and prepare to assemble the drawers. First, insert the drawer bottoms (FF) into place but don't glue them. A couple of brads in the bottom edge of the drawer backs will hold them in their place.

Finally, mount the back of your dry sink (U). Sand everything smooth, clean up any dust, and apply the finish of your choice. That's it !

LIST OF MATERIALS

(finished dimensions in inches)

A	Face stiles(2)	3/4 x 2 x 30-3/4
B	Face rail	3/4 x 2 x 33
C	Face center stile	3/4 x 2 x 25-3/4
D	Middle rails (2)	3/4 x 1-3/4 x 15-1/2
E	Bottom rail	3/4 x 3 x 33
F	Sides (2)	3/4 x 16-1/2 x 30-3/4
G	Bottom	3/4 x 16-1/2 x 36-3/4
H	Top	3/4 x 18-1/4 x 39
J	Braces (2)	3/4 x 2 x 35-1/2
K	Top cleat strip	3/4 x 3/4 x 35-1/2
L	Base front	3/4 x 5 x 38-1/2
M	Base sides (2)	3/4 x 5 x 18
N	Cleat strips (2)	3/4 x 3/4 x 16-1/2
P	Cleat strip	3/4 x 3/4 x 34
Q	Drawer guides (2)	3/4 x 1-1/4 x 15-1/2
R	Drawer guides (2)	3/4 x 1-3/4 x 15-1/2
S	Guide	3/4 x 2 x 15-1/2
T	Guide	3/4 x 3 x 15-1/2
U	Back	1/4 x 36-1/4 x 28
V	Splash board back	3/4 x 5 x 35-1/2
W	Splash board sides (2)	3/4 x 5 x 17-3/4
X	Splash board front	3/4 x 3-1/2 x 37
Y	Splash board shelf	3/4 x 3-1/4 x 38
Z	Door stiles (4)	3/4 x 2 x 20-1/4
AA	Door rails (4)	3/4 x 2 x 13
BB	Door panels (2)	3/4 x 12-3/4 x 17



CC	Drawer fronts (2)	3/4 x 5-1/4 x 16-1/4
DD	Drawer sides (4)	3/4 x 4-7/16 x 16
EE	Drawer backs (2)	3/4 x 3-15/16 x 13-15/16
FF	Drawer bottoms (2)	1/4 x 14-11/16 x 16

MISCELLANEOUS

(20)	1/4" dia. x 1-1/2" long dowels
(30)	3/8" dia. x 1-1/2" long dowels
(100 approx.)	#10 x 1-1/2" flat head wood screws
(2 pairs)	Recessed cabinet hinges
(4)	1-1/4" dia. knobs
(12)	1/2" dowel buttons

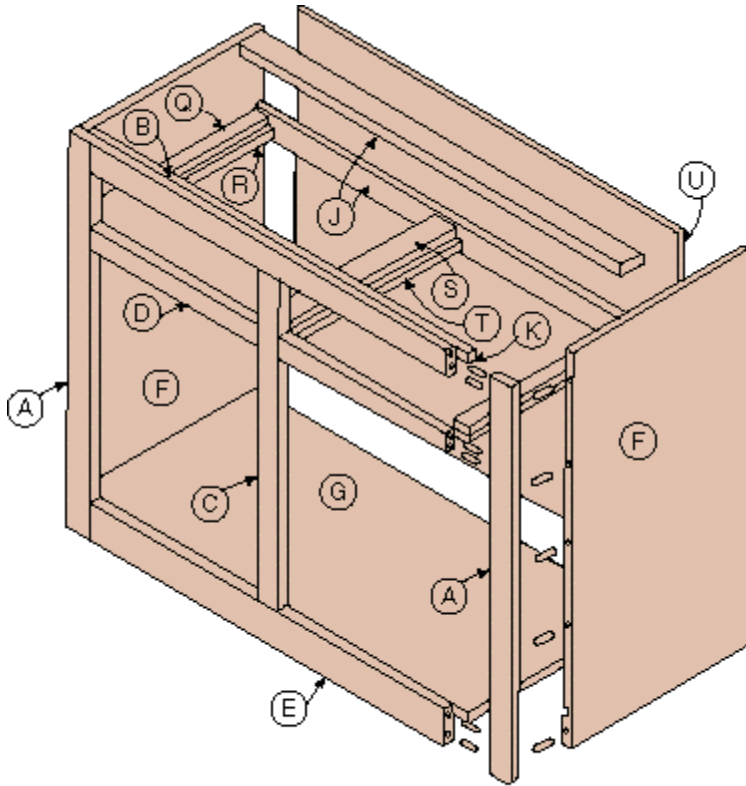

CARCASE ASSEMBLY

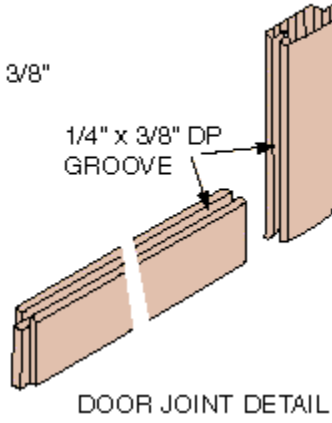
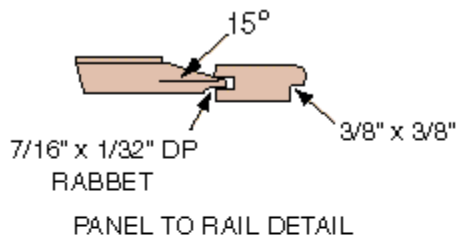

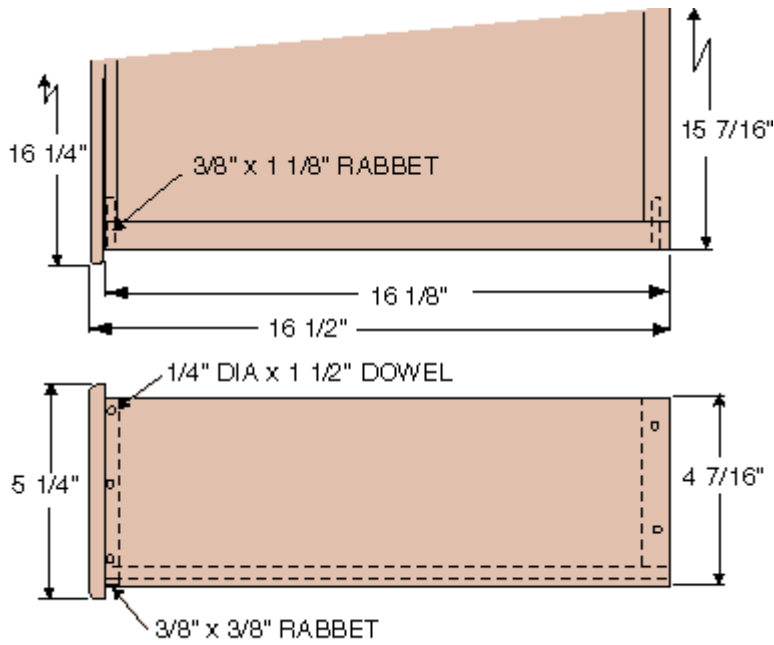

DRAWER LAYOUT

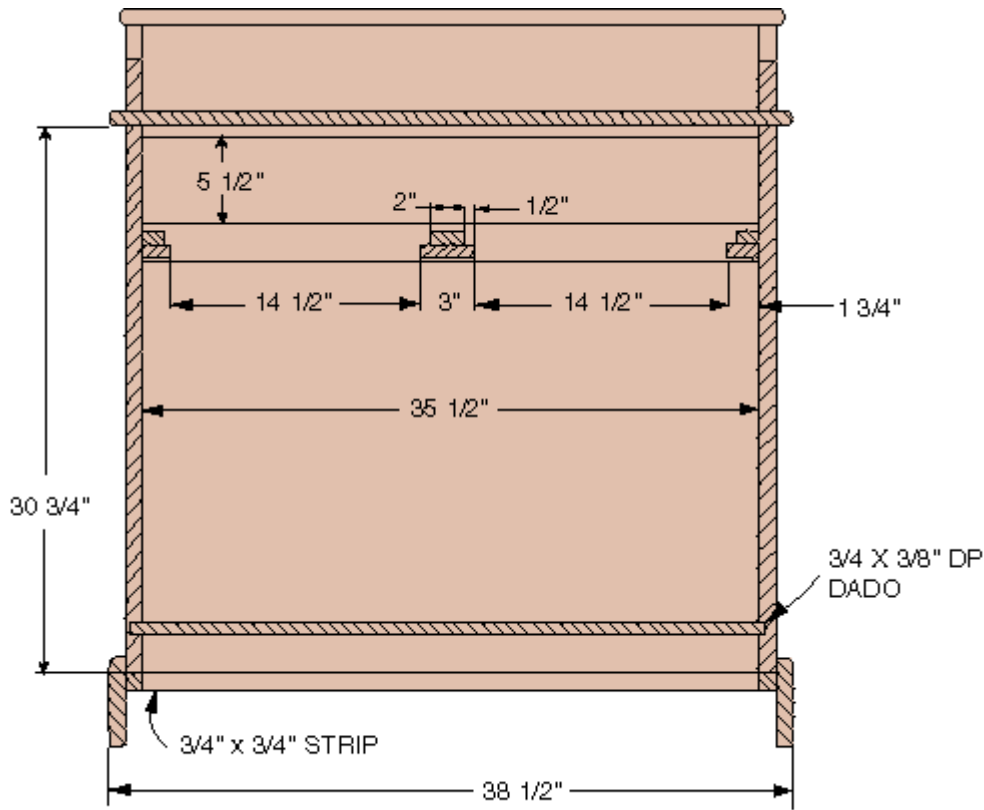

SECTIONAL LAYOUT

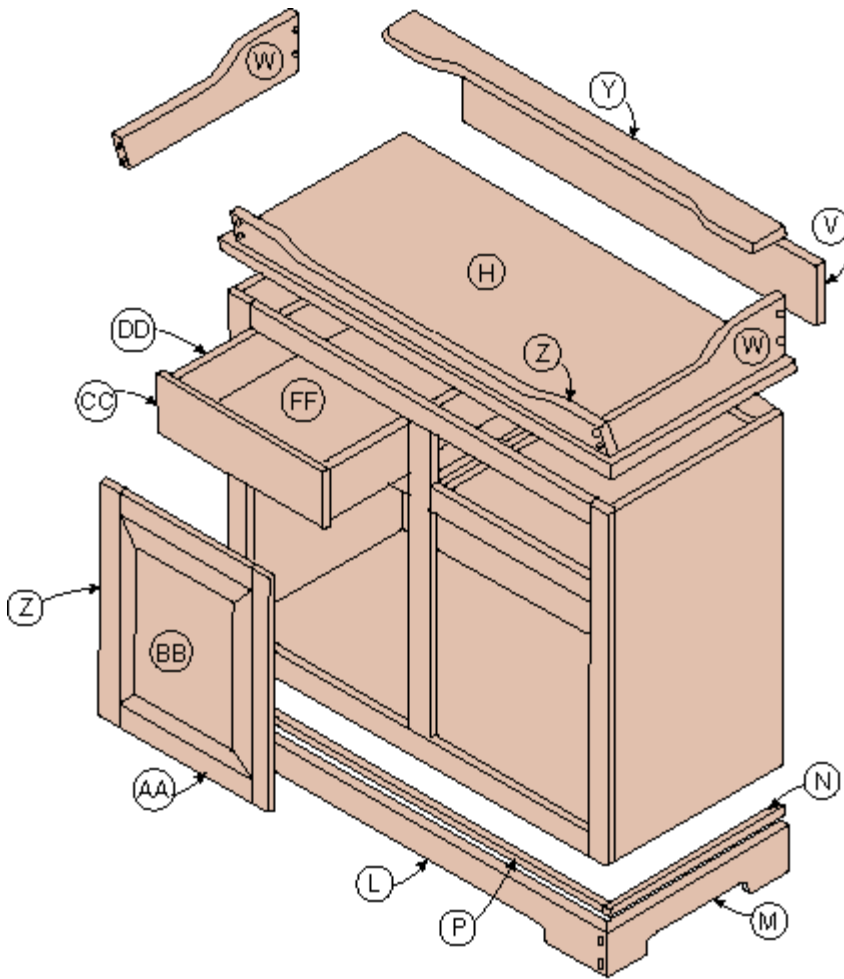

FINAL ASSEMBLY



THE HANGING WALL DESK

Here's a multi-purpose kitchen Information Center that the entire family will find usefull...and it's fast and easy to build, too!



One of the most-often used "appliances" in a modern kitchen is the phone. And whether it's a corded or cordless model, many kitchens have limited counter space...making wall-mounting the best (or only) alternative. This solves the problem of where to place the phone, but it often leaves no convenient space for the phone book or for jotting down messages. That's where this handy, easy-to-build desk comes in. It not only gives you the space you need for jotting down phone messages...it can also be a terrific, out-of-the-way spot for laying an open cookbook (without fear of dribbling tomato sauce or gravy on it) while you're cooking, storing your recipe cards or a host of other applications. So, with all that said, let's get started.

We used maple for our desk, but any hardwood will do, keeping in mind that if you have some hard-pressing writers in the family, super-soft woods such as pine or poplar could take and hold a permanent impression of the messages written on their surfaces.

SIZING NOTE: Check the size of your phone book before cutting your pieces to size. Some of the dimensions may have to be adjusted to accommodate the phone book from your area. Also, you may choose to adjust the depth and width of the small drawer to hold common 3" x 5" recipe cards. Doing this, of course, will affect the size of the phone book compartment, as well (and perhaps the overall size of the desk). Start by using your bandsaw to resaw the stock you'll need to make the 1/2" thick bottom, shelf and drawer components (G,H,J,K,L,M). Then, glue-up these pieces of stock, cut them to size and run them through your thickness planer to bring them to a consistent thickness. Next, glue up the wood you'll need to make the balance of the larger components (A,B,E) and cut them to size.



NOTE: For the two sides, we started with a single piece of stock, 3/4" x 10" x 20-3/4"...set our table saw's miter gauge to 65 degrees...and cut diagonally across the middle to create our two sides with minimum waste.

Now, set up your dado blades to cut the 1/2" wide x 3/8" deep dadoes in the sides (A) that will accept the bottom and shelf. Cut the same size (1/2" x 3/8") groove and rabbet in the back to accept the 1/2" thick shelf (H) and desk bottom (G). Using the same 1/2" dado set-up, re-adjust your table saw's depth-of-cut to 1/4" and cut the dadoes in the top surface of the bottom (G) and the bottom surface of the shelf (H) to accept the drawer partition (J).

Re-set your dado blade for a 3/4" wide cut and create a 3/8" deep stop rabbet in the sides (A) to accept the 3/4" thick back (E). This rabbet cut should stop at the bottom of the desk bottom (G). Use a chisel to square the end of your cut.

Using your bandsaw or scroll saw, cut the bottom profiles for the sides (A), then drum sand the edges smooth.

Tilt your saw table to 25 degrees and use your rip fence as a guide (see Fig 1.) to cut the beveled top edge of the back (E). Without changing your table tilt, re-set your rip fence to cut the same 25 degree bevels on the top edge of the front (F) -- and the front edge of the top strip (C).

Assemble and glue the partition (J) to the shelf (H) and bottom (G). Glue and clamp the sides (A) to the shelf and the bottom. Glue and assemble the back (E), front (F) and top strip (C) into position. Cut and assemble the stock for the drawer. Finish sand the entire project and apply the finish of your choice. Attach the top to the top strip with hinges and enjoy.

Desk Assembly

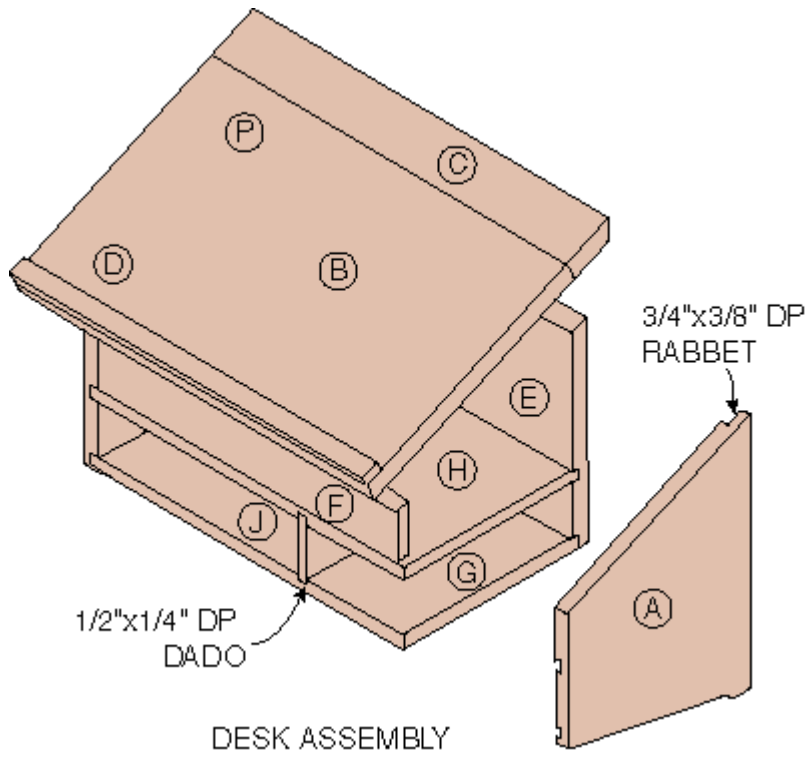

Desk Layout

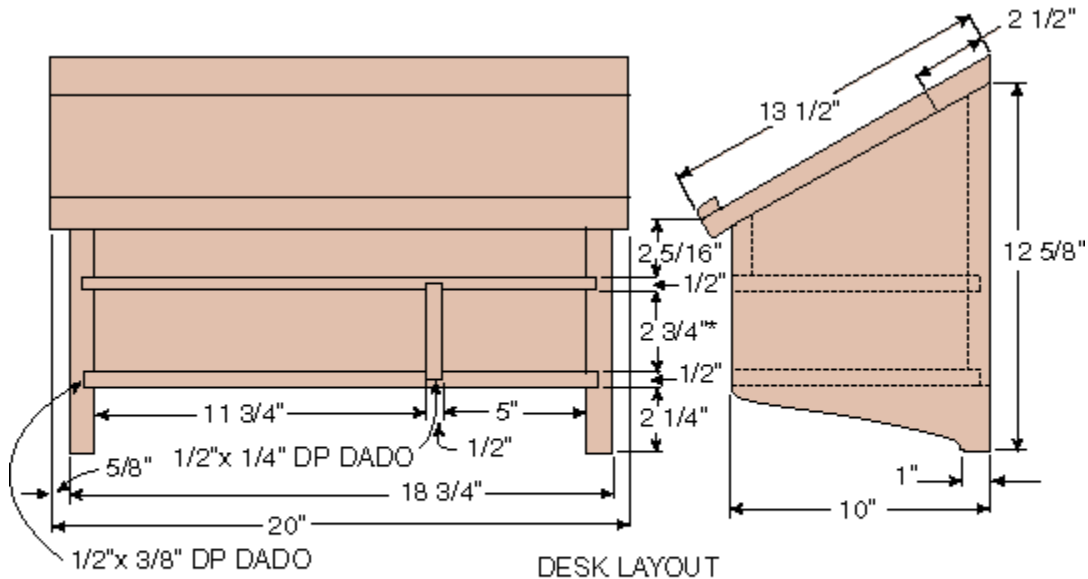

*You may need to vary this dimension to fit your phone book. Adjust other dimensions accordingly.

Drawer Layout

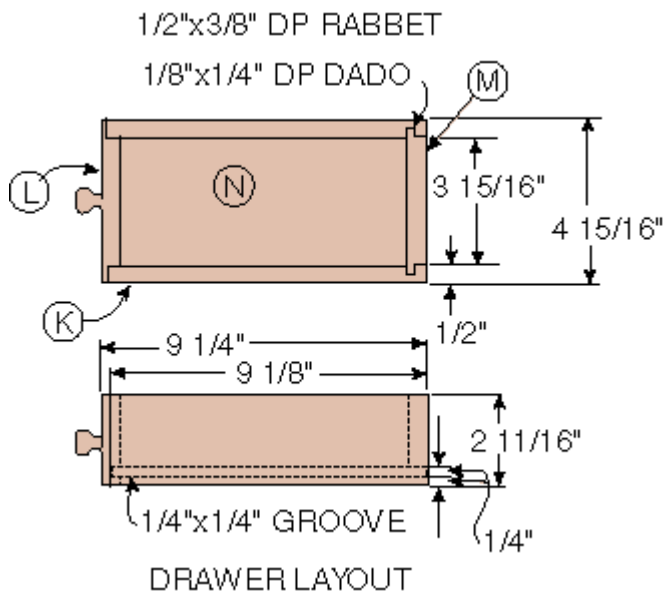



LIST OF OF MATERIALS
(finished dimensions in inches)

A	Sides (2)	3/4 x 10 x 12-5/8
B	Top	3/4 x 11 x 20
C	Top strip	3/4 x 2-1/2 x 20
D	Ledge	3/8 x 3/4 x 20
E	Back	3/4 x 10-3/8 x 18
F	Front	3/4 x 2-5/16 x 17-1/4
G	Bottom	1/2 x 9-5/8 x 18
H	Shelf	1/2 x 9-5/8 x 18
J	Partition	1/2 x 3-1/4 x 9-1/4
K	Drawer sides (2)	1/2 x 2-11/16 x 9-1/8
L	Drawer front	1/2 x 2-11/16 x 4-15/16
M	Drawer back	1/2 x 2-3/16 x 4-7/16
N	Drawer bottom	1/4 x 4-7/16 x 9

HARDWARE

P Butt hinges (2)

CLASSIC ROCKING HORSE



Making a child's toy can be a lot of fun. The hours spent cutting, sanding, assembling and finishing a toy are richly rewarded by the happiness shown on a child's face when he or she receives that toy. There's little else to compare with it.

For generations, one of the most popular of all children's toys has been the rocking horse. Little buckaroos and buckarettas love to climb in the saddle and ride the living room range, looking for strays and chasing the bad guys.

The easy-to-follow plans presented here will help you create this family heirloom in about 12 hours and have it ready to occupy its treasured space under your family tree this Holiday season.

Step 1: Getting Started

The first step is to make your full-size patterns. There are two ways you can accomplish this. The first is to follow the drawings provided and make full-scale patterns for parts A through H. Begin by drawing 1" grids on pieces of cardboard or artist's board and then duplicate your drawings onto this larger grid. The optional method involves going to a local copy center and enlarging the patterns provided here by using a large format, roll-fed copy machine. These machines typically enlarge up to 400% in a single pass, so you'll have to make multiple passes to get to the desired dimensions.

Once you've drawn (or copied) your patterns, cut them out and trace them onto a 6-foot and 8-foot length of 2" x 12" stock (we used yellow pine). Work around any knots or defects in the wood and for maximum strength, be sure to follow the grain direction indicated by the arrows on the drawings.



Next, cut your stock into manageable sized pieces before attempting to cut out the final shapes with your bandsaw, saber saw or scroll saw. The saddle (G) can be made from your choice of 2" x 12" stock, then shaped....or from 3/4" stock (H - not shown) and then upholstered (see Step 11).

Cut the braces (J) to size and chamfer the edges using your Table Saw, Disc Sander or Jointer.

Step 2: Drill the holes

Drill the holes for the handle, eyes and tail where noted in the drawings. Drill the alignment holes in parts B,C,D,E & F, as shown. Locate these holes very carefully since they will be used to align the various parts of the horse during assembly. Drill the holes for the legs (parts B & C) from the back, being sure not to drill all the way through the stock to their front sides.

Step 3: Sand all contoured parts

Sand all contoured parts using your disc and drum sanders. Tape the two rockers (A) together with double-faced tape and pad sand them together at the same time to be certain their contours are identical.

Step 4: Use the Shaper

Use the shaper with a Tongue Cutter to create the 1/4" deep groove in the back of the head (E) that will accept the rug yarn mane.

Step 5: Mark the outside edges

Mark the outside edges of parts B,C,D,E & G and round them over on the shaper using a 1/4" quarter-round cutter -- or with your router and a rounding-over bit. Do not round the front edges of the neck where it meets with the body...or the straight, vertical edge at the rear of piece E, since these edges must be square when assembled.

Step 6: Assemble the main body

Use pieces of 3/8" dowel rod to align the parts when gluing and clamping, but DO NOT glue the dowels in place yet. If you prefer, the body can also be assembled with #10 x 2-1/2" flathead wood screws. Sand the body assembly on the disc sander so all the parts are flush.



Step 7: Mount the legs

Align the legs with 3/8" dowel rods that extend through the body and into the legs on both sides. Disassemble, then glue and clamp the legs into place with the dowel rods. The legs can also be assembled without the glue by using #10 x 2-1/2" flathead wood screws. This approach allows you to disassemble the finished rocking horse for shipping or storage, if necessary. The screws can be covered with stain or paint later.

Step 8: Center the front and rear braces

Center the front and rear braces (J) on the feet and attach with two #10 x 2" flathead wood screws driven up through the braces and into the soles of each foot. Place the horse with the two attached braces on the rockers. Make certain the horse is sitting level on the rockers by sliding it back and forth until the body is parallel with the floor. Fasten the front and rear braces to the rockers using #10 x 1-1/2" flathead wood screws. Attach the remaining three braces (J) to the rockers using #10 x 1-1/2" flathead wood screws. Round off the sharp edges of the rockers at this point, being sure they remain fairly square for maximum stability.

Step 9: Attach the saddle

The 3/4" thick upholstered saddle board (H) is attached with #10 x 1-1/2" flathead wood screws. If you choose the 1-1/2" thick solid wood saddle (G), it is attached with 3/8" dowels and glue. Determine the locations for the three saddle mounting holes on the bottom of the saddle and drive a small brad into the center of each hole location, leaving about 1/2" of the brad protruding. Snip the heads off these brads using wire cutters. Turn the saddle over and set it carefully in position on the horse body. Lightly tap the top of the saddle with your hand or fist to transfer the hole centers to the horse body. Turn the saddle over and pull the brads out. Drill three 3/8" blind holes in the bottom of the wood saddle (G) and the top of the horse body at the indicated locations. Dowel and glue the saddle to the body. Place a weight on the seat or clamp it firmly into position while the seat dries to assure good adhesion.

Step 10: Apply the stain or finish

Apply the stain or finish of your choice. For this project, one coat of stain and two coats of polyurethane varnish were used.



Step 11: (Optional) Upholster the saddle

Use your bandsaw to cut out and chamfer the top edge of a piece of 2" thick foam rubber. Then, cut the saddle covering out of leather, vinyl or cloth. Attach the front edge of the material to the front of the 3/4" thick saddle board using staples or decorative upholsterer's tacks. Pull the material back over the foam. Locate the back edge and insert an upholstery tack strip (available from upholstery shops) through the covering material. Fold the tack strip under the foam and pound the tacks by hitting the seat with a rubber mallet. Tack the sides of the covering material under the saddle and along the sides. Pleat the material as you go by folding it under and securing it with upholstery tacks or staples.

Step 12: The mane.

To make the horse's mane, use a skein of rug yarn and unloop it. Cut it into three equal parts, each about 14" long. Next, take a piece of 1/2" wide durable tape (reinforced duct tape, etc.) and lay it out on a flat surface with its sticky side up. Lay the yarn across the tape and press it down firmly to secure it. For additional strength, stitch the yarn onto the tape with a sewing machine. After the yarn is secured to the tape, glue the mane into the head groove. Use a small stick to force it into the groove. Several small pieces of wood can be used to wedge the mane in place while the glue dries.

Step 13: The tail.

The tail is made from a single skein of rug yarn, unlooped and cut. Wrap 2" of one end of this yarn with a section of yard and tie it securely. This will help the tail stand out from the body. Glue the tail into place.

Step 14: Eyes and ears.

The eyes can be found at most craft shops. The eyes used on this project have 1/4" stems and are glued into place with yellow woodworker's glue. Or, if you prefer, the eyes may simply be painted on.

To make the ears, cut four triangles out of soft leather or vinyl. Put two triangles face-to-face and stitch them together where indicated in the drawing. Turn them inside-out, fold the bottom corners together and attach them to the horse's head with small screws.



LIST OF MATERIALS

(finished dimensions in inches)

A	Rockers (2)	1-1/2 x 7 x 40-3/4
B	Front legs	1-1/2 x 5-5/8 x 19-1/8
C	Rear legs (2)	1-1/2 x 7-1/8 x 20-1/4
D	Sides (2)	1-1/2 x 9 x 21-3/8
E	Head	1-1/2 x 11 x 19-1/4
F	Rear body	1-1/2 x 8-3/4 x 13-3/4
G	Wooden saddle	1-1/2 x 10-1/2 x 8-1/2
H	Upholstered saddle (optional)	3/4 x 10-1/2 x 8-1/2
J	Braces (5)	3/4 x 3-1/2 x 14
K	Handle	3/4 dia. dowel x 9

MISCELLANEOUS

#10 x 1-1/2" flathead wood screws
#10 x 2" flathead wood screws
#10 x 2-1/2" flathead wood screws
3/8" dowel rod
Material for saddle covering
Rug yarn (2 skeins)
Leather or vinyl for the ears
Eyes (2)

Final Assembly

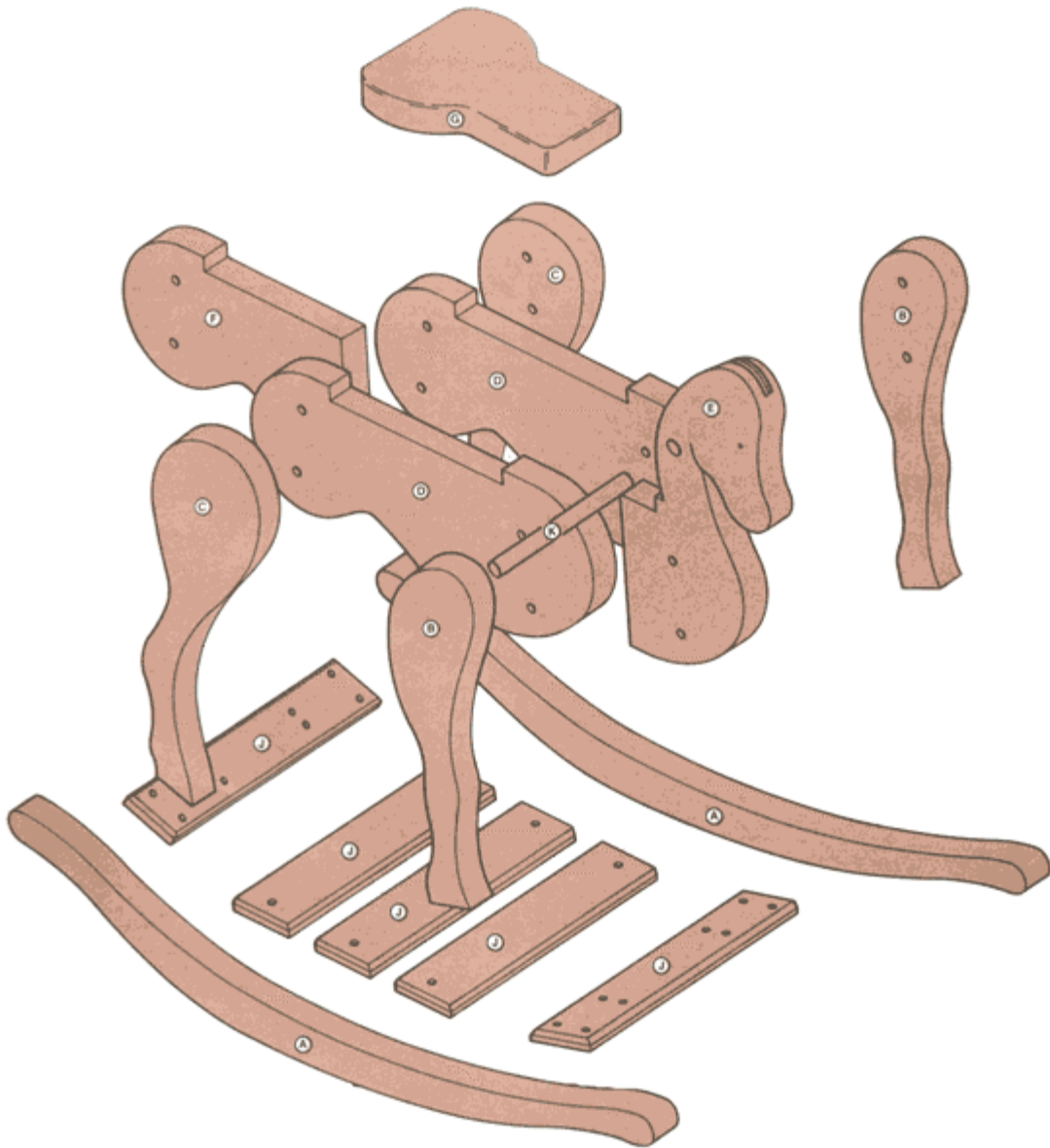

Head (E)

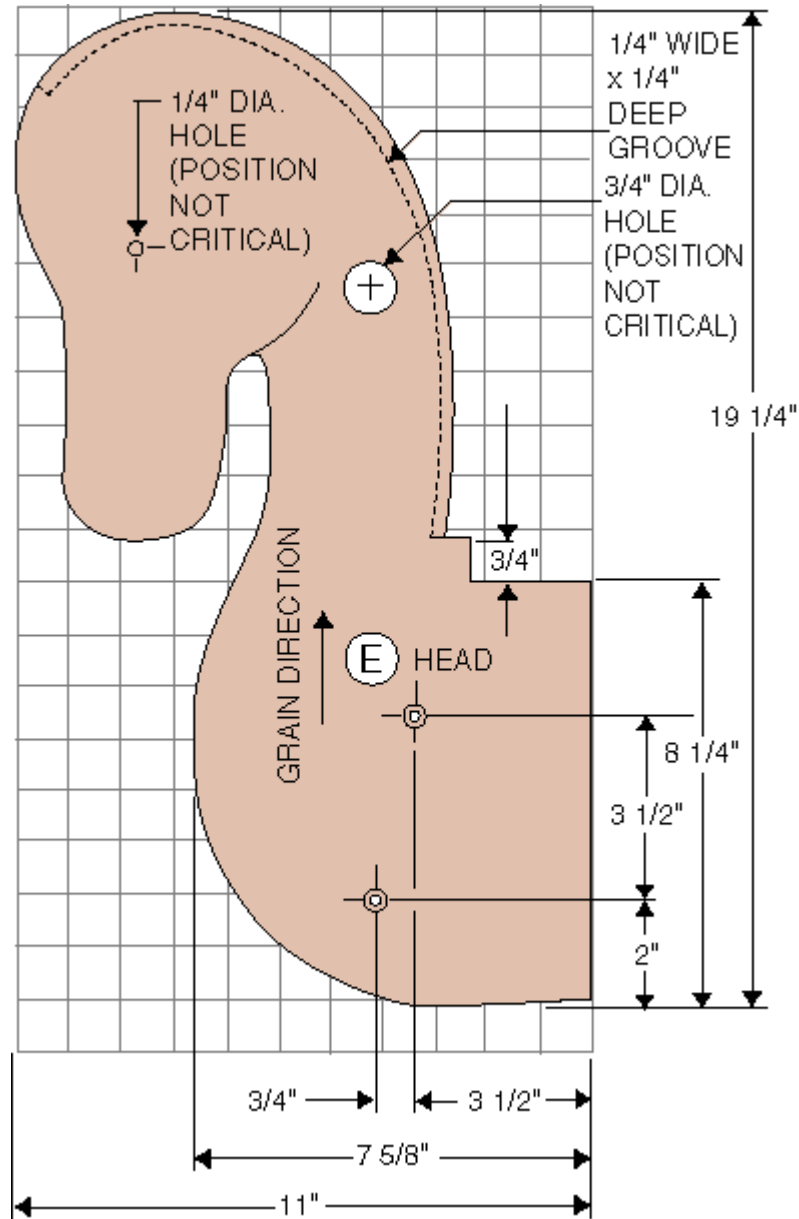

Sides (D)

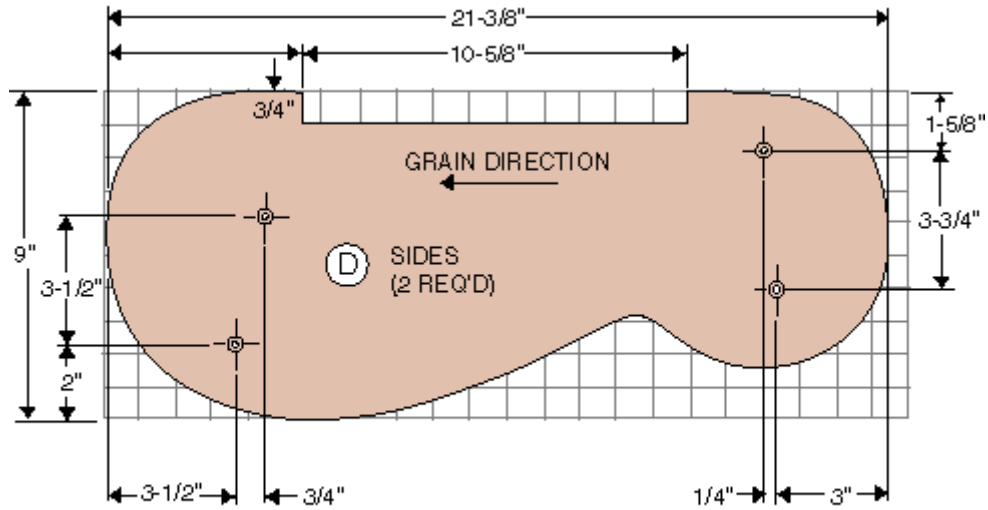

TIP: MAKE PATTERN FOR PART (D) FIRST AND TRANSFER HOLE ALIGNMENT POSITIONS TO OTHER PARTS.

Rear Body (F)

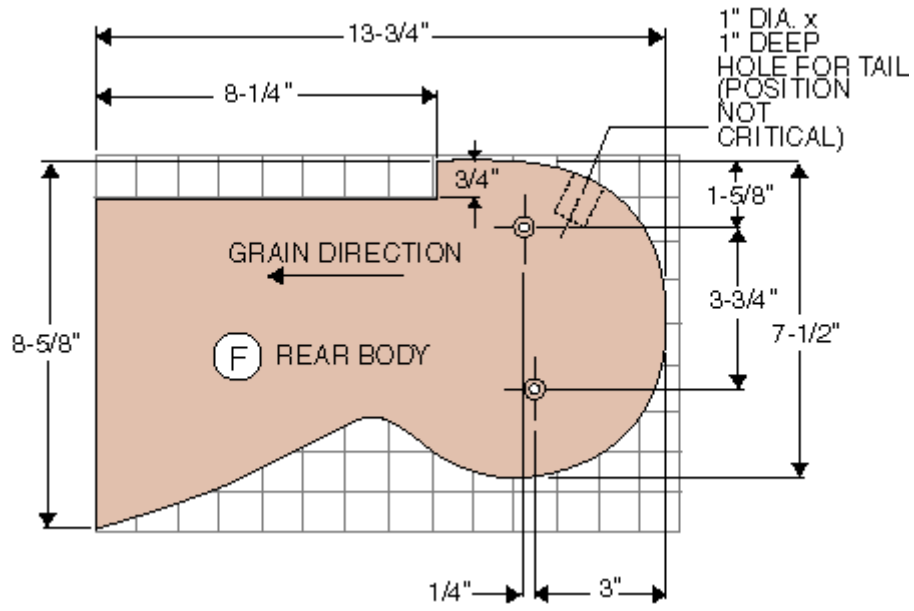

Saddle (G)

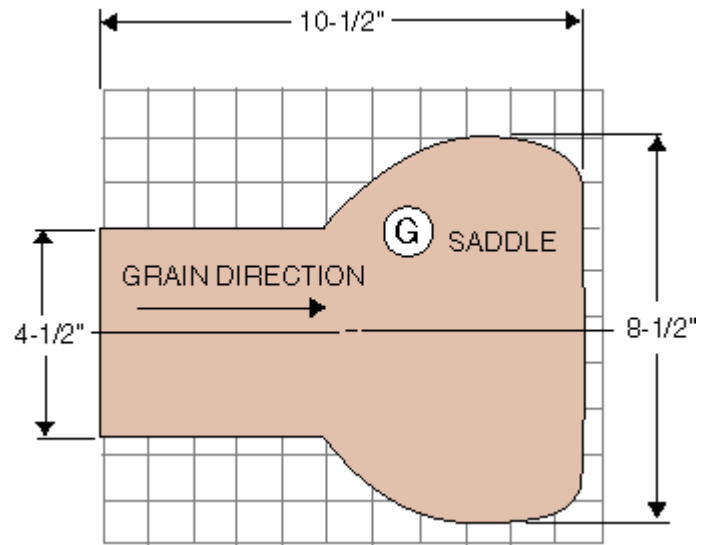

Front Leg (B)

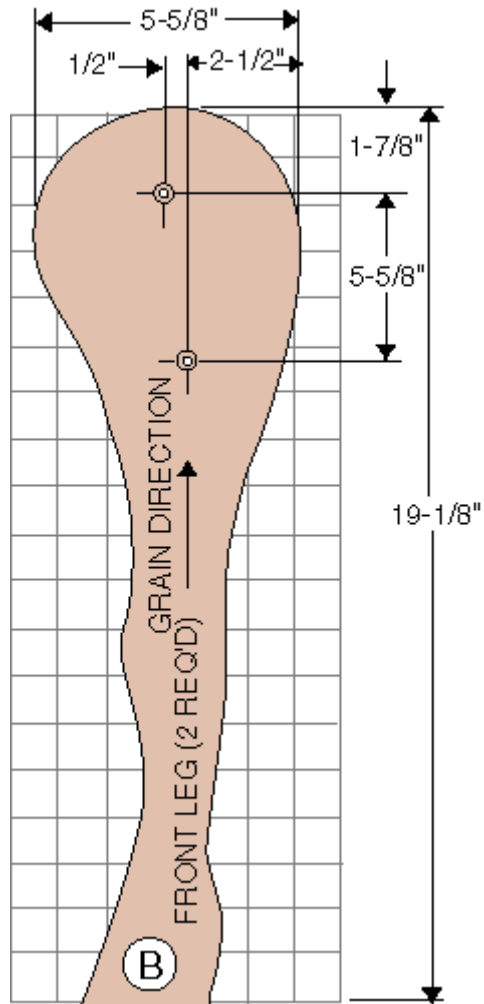

Rear Leg (C)

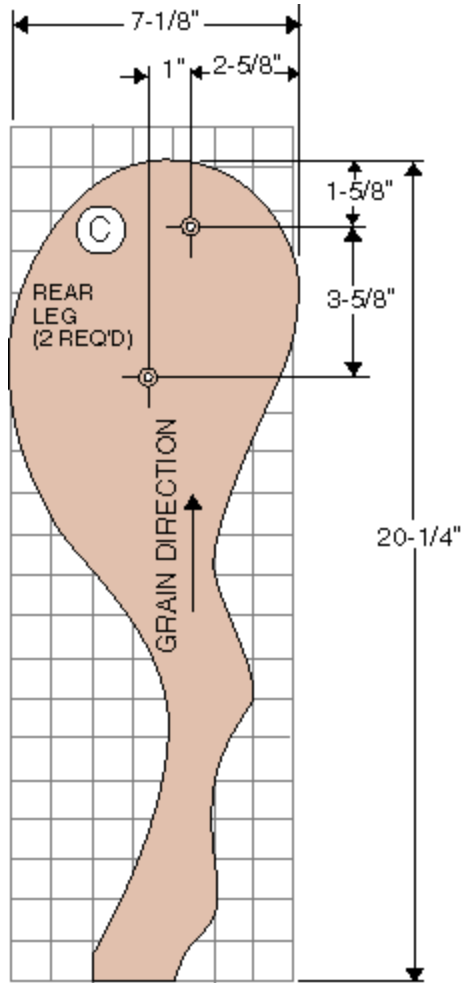

Brace (J)

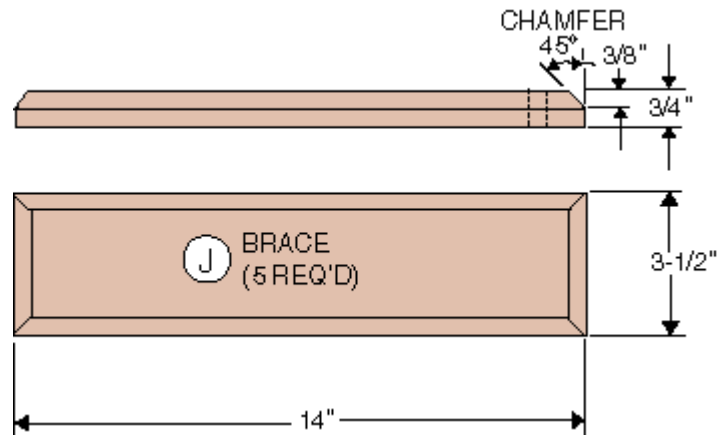

Rocker (A)

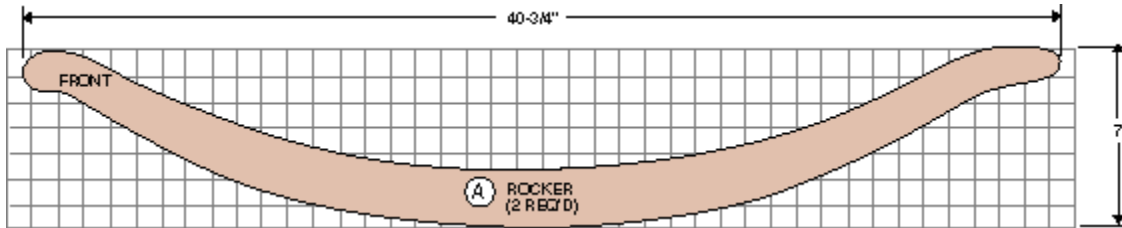

Ear Detail

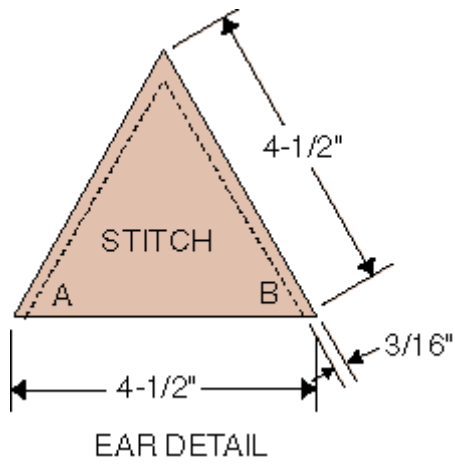

CHILD'S CHALKBOARD



All children love to draw and doodle. Crayons and/or markers on paper are a great choice...but errors made with these materials can be difficult or impossible to correct. On the other hand, colored chalks on a chalkboard like this can be a lot less frustrating...and that can make everything a lot more fun, too.

Just let these easy-to-follow plans guide you to the creation of a project that's handsome enough to display in any room of the house...and enjoyable enough that your favorite kid (or kids) will look forward to hours on end of self-entertainment. We made this one out of hard maple with contrasting cherry drawer sides. Both of these are durable woods that are a true joy to work with.

Building The Framework

Be sure to select stock that's of a consistent, 3/4" thickness. If you have difficulty doing so and own a thickness planer, be sure to plane the stock for the stiles and rails (A, B, C) to 3/4" and cut them to size, according to the [Bill Of Materials](#). If you are going to plane your own stock, joint one edge of these pieces first, then run them all through your planer at the same time. This way, you're certain to get the straightest, most consistently thickened stock possible. Note that the inner rail (C) is 1/2" wider than the other two rails (B).



Using your dado setup, cut the 2" long x 3/8" deep lap joints in the ends of the stiles (A) and rails (B), as shown. If you make these joints about 1/32" or less wider than the indicated 2", you can sand the joints off flush once you've assembled the framework.

CAUTION: Using the dado setup requires working without the upper saw guard. Be extremely careful when performing this operation.

Next, lay out and cut the mortises and tenons for attaching the inner rail (C) to the stiles (A). The tenons on each end of the inner rail (C) should be 1/4" thick by 2" long by 1/2" deep. Now, cut the mortises using your Shopsmith Hollow Chisel Mortising setup or your Router setup with a 1/4" straight bit. If you don't own either of these setups, you can drill your mortises out with a 1/4" brad point bit, then clean them up with a bevel-edged wood chisel. To keep the tenons from "bottoming-out", make the mortises just slightly deeper than the 1/2" tenons -- 9/16" is about right. Dry fit the frame assembly to be sure everything goes together properly.

Using your dado or router setup, cut a 1/4" deep by 3/8" wide rabbet along the inside back edges of the stiles (A), top rail (B) and inner rail (C) to accept your 1/4" thick chalkboard. NOTE: If you're using a purchased chalkboard that's thicker than 1/4", adjust your rabbet depth accordingly.

Glue and assemble the stiles (A), rails (B) and inner rail (C) to create the framework. Be sure to check carefully for squareness at all joints and set aside to dry.

Building The Drawer Box And Drawers

Once again, if you have a thickness planer, begin by planing all stock you plan to use for pieces D through J to the indicated 1/2". Next, joint and cut all the common widths for the drawer box and drawers, then cut all the pieces to length, according to the Bill Of Materials.

IMPORTANT: Since you'll be using finger lap construction for these pieces, it would be a good idea for you to rip the drawer box sides (G) to about 1/16" wider than indicated...and crosscut pieces D, E, H, I and J to about 1/16" longer than indicated. This will allow the fingers of your joints to protrude about 1/32" past their mating workpieces when assembled. These protruding fingers can then be sanded flush once the glue-up has dried.

Creating the finger joints can be accomplished with the aid of a special finger lap fixture...which can be used with your dado or router table setup. We used the dado setup to make our chalkboard. [Click here](#) to go to a special linked



article we've prepared to help you build and use the fixture you'll need to cut the joints for the chalkboard.

Configure your dado setup according to the instructions included in the linked article. In our case, you'll need to make a finger lap fixture for cutting 1/2" fingers, instead of the 3/8" fingers in the linked article. Be sure to cut each finger about 1/32" longer than 1/2" (or 17/32"). This will allow the ends to be sanded flush once everything is assembled. Start by cutting the joints for the drawer box top, bottom and sides (D, E & G)...then, cut the fingers for the drawer fronts, backs and sides (I, J & H).

Next, cut the 1/4" deep cross-grain dados in the drawer box top and bottom (D & E) to accept the drawer partitions (E). We used the dado setup to cut ours and for appearance purposes, made them "blind" in the front of the box. If you use this approach, you'll have to use your bandsaw or scroll saw to carefully remove the front edges of each partition so it fits into the blind dado. As an alternative, you could cut also these stopped grooves with your router and a 1/4" straight bit.

Sand the inside surfaces of all drawer box pieces and dry fit. When you're sure everything fits properly, disassemble the box, apply glue and clamp together. Check for squareness, wipe away any excess glue immediately with a damp cloth and set the box aside to dry.

Re-configure your dado setup to make a 1/4" wide x 1/4" deep cut and rout the grooves 1/4" up from the inside bottoms of the drawer fronts (I), backs (J) and sides (H) to hold the drawer bottoms (K). IMPORTANT: Be careful to stop these grooves before they reach the fronts and backs of the drawer sides (H) or the drawer bottoms will show through when assembled. Again, as an alternative, these stopped grooves could also be cut with a router set-up and 1/4" straight bit.

Cut the drawer bottoms (K) to size from 1/4" birch or maple plywood...or hardboard (Masonite), if preferred. Test assemble all drawer pieces, disassemble, glue, clamp, check for squareness, wipe off any excess glue with a damp cloth and set aside to dry.

Once the assembled drawer box and drawers have dried completely, carefully sand all assemblies smooth and flush with a belt sander, then finish sand them with fine sandpaper. Be sure to remove any sharp edges or corners that could injure children.

Rout a 1/4" deep by 3/8" wide rabbet around the inside back of the frame to accept the chalkboard. Square the corners with a chisel.



The Chalkboard

Ready-made chalkboards are available through office supply and specialty stores, or, if you prefer, you can make your own by spraying tempered hardboard (Masonite) with a special chalkboard paint that's available at craft stores.

Assembly

Attach the completed drawer box assembly to the frame assembly with #8 x 1-1/4" wood screws. Drill pilot holes in the chalkboard and frame assembly to accept #6 x 5/8" wood screws but do not attach them at this time. Cut and glue the runners (L) to the bottoms of the drawers. These thin, 1/32" x 1/2" x 4-1/2" strips will make the drawers slide easier and give you an equally spaced gap around all drawers.

If you like, you can add the decorative apple and "ABC" appliques that are cut on your scroll saw from 1/4" plywood or Masonite. Paint them with a high gloss enamel, then use the same enamel to paint the matching drawer pulls. Finish the entire chalkboard project (not the actual chalkboard) with a coat of semi-gloss polyurethane. Mount the chalkboard into the frame, attach the appliques and insert the drawer pulls.

BILL OF MATERIALS

(finished dimensions in inches -- use maple, except where noted)

FRAME		
A	Stiles (2)	3/4 x 2 x 28
B	Rails (2)	3/4 x 2 x 36
C	Inner Rail (1)	3/4 x 2-1/2 x 33
DRAWER BOX		
D	Top (1)	1/2 x 5 x 36
E	Back	1/2 x 5 x 36
F	Partitions (2)	1/2 x 5 x 3-1/16
G	Sides (2)	1/2 x 5 x 3-9/16
DRAWERS		
H	Sides (6)	1/2 x 2-1/2 x 5
I	Fronts (3)	1/2 x 2-1/2 x 11-5/16
J	Backs (3)	1/2 x 2-1/2 x 11-5/16
K	Bottoms (3)	1/4 x 4-7/16 x 10-11/16

L	Runners (6)	1/32 x 1/2 x 4-1/2
---	-------------	--------------------

HARDWARE

- Chalkboard (1) 1/4 x 21-1/8 x 32-5/8
- Wooden Drawer Pulls (3)
- #8 x 1-1/4" Flathead Wood Screws (5)
- #6 x 5/8" Wood Screws (8)

Drawer Layout

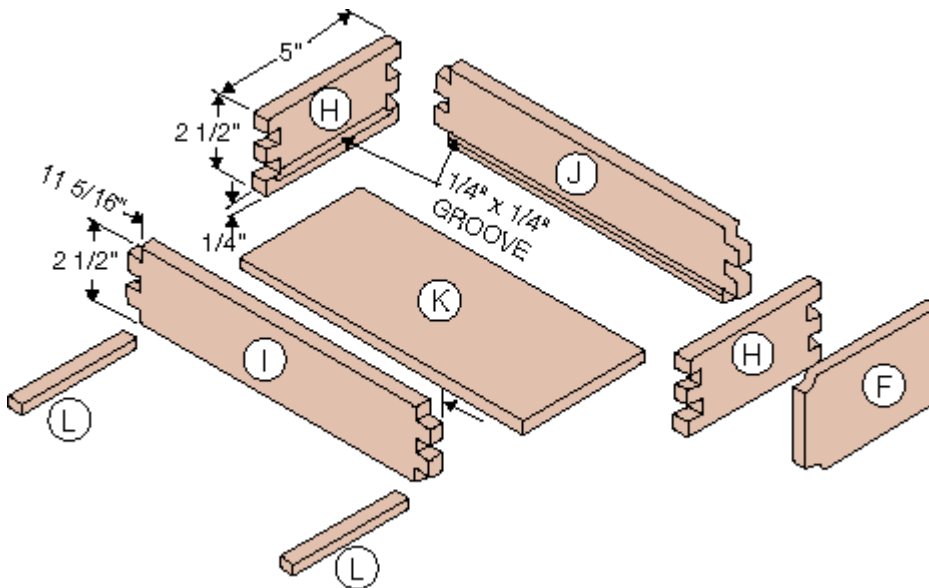

Drawer Box Layout

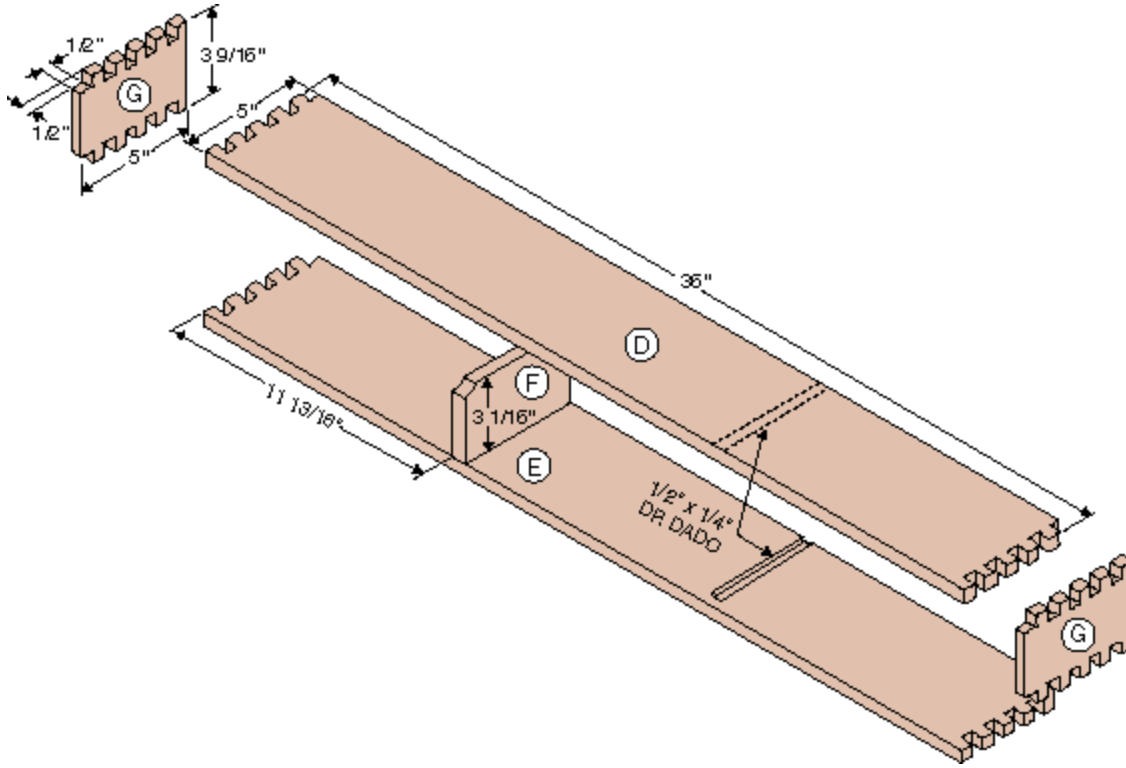

Frame Layout

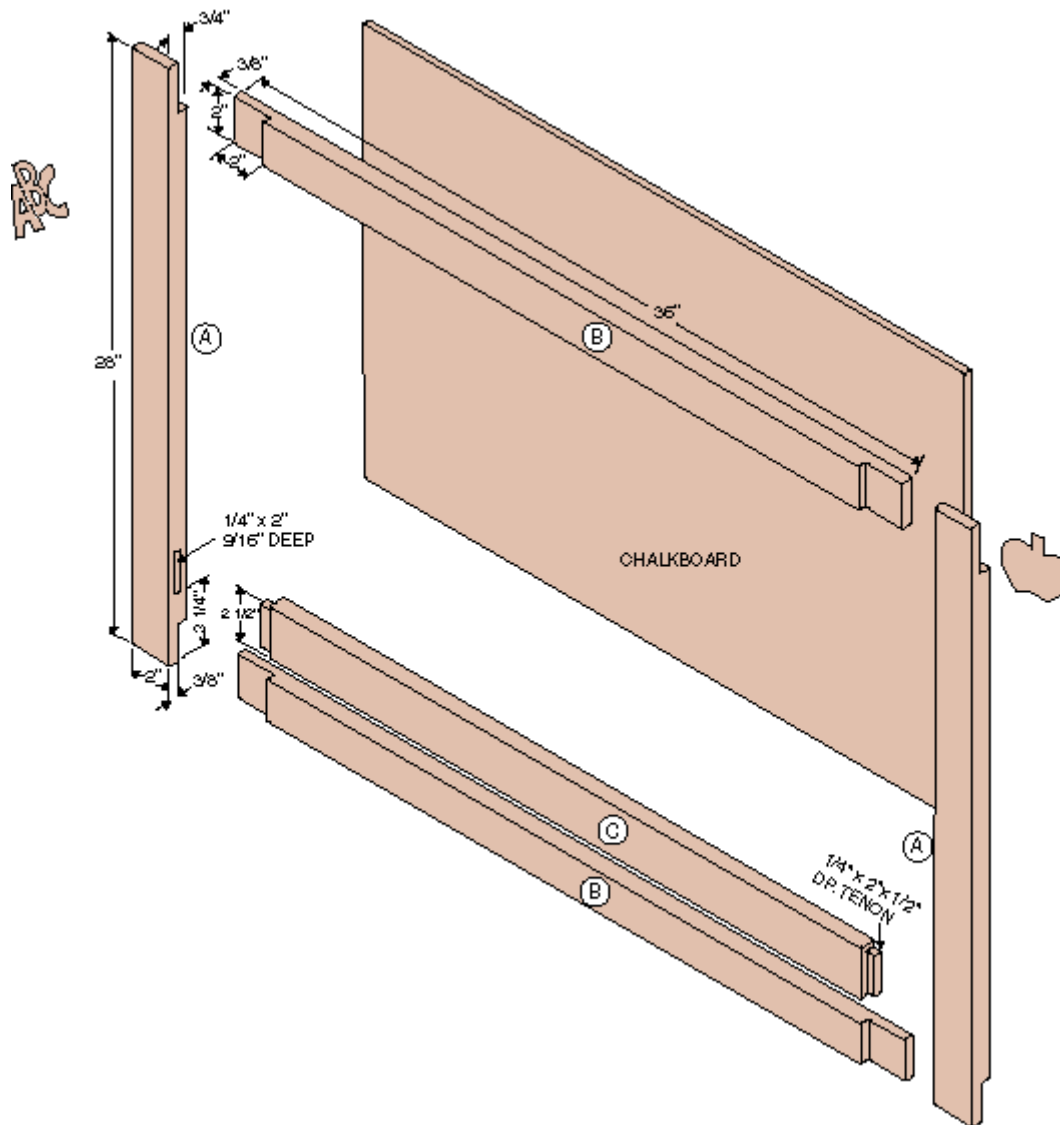

Decoration Layout

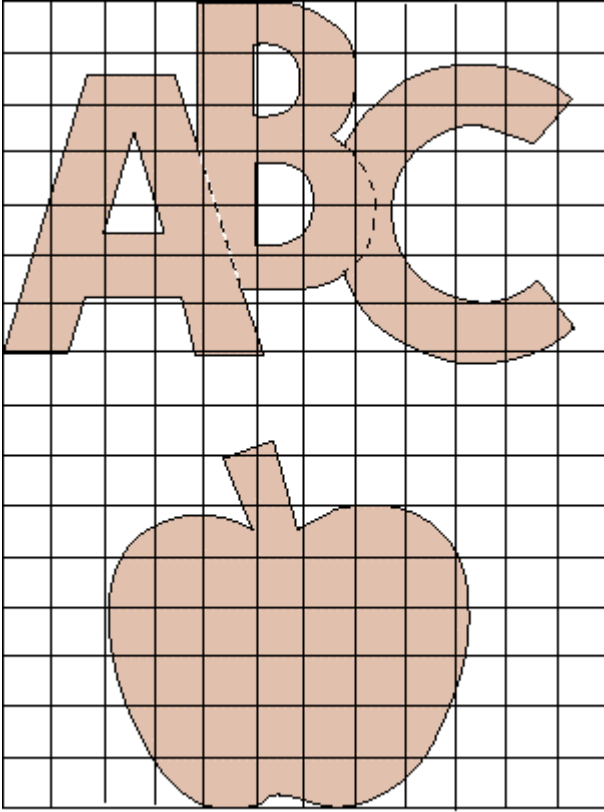

1 GRID SQUARE = 1/2"

WINE RACK-1

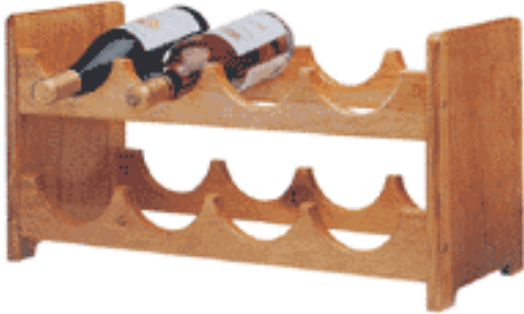

Creating The Components

Start by laying out the four rails on two pieces of stock (A) as shown in Fig 1. By following the procedure outlined here, you'll be able to get two rails from each piece of stock and save time in the process. Center four 4" diameter circles on the rail stock, leaving a 1/2" space between the circles. Use a hole saw, scroll saw or saber saw to cut out the circles.

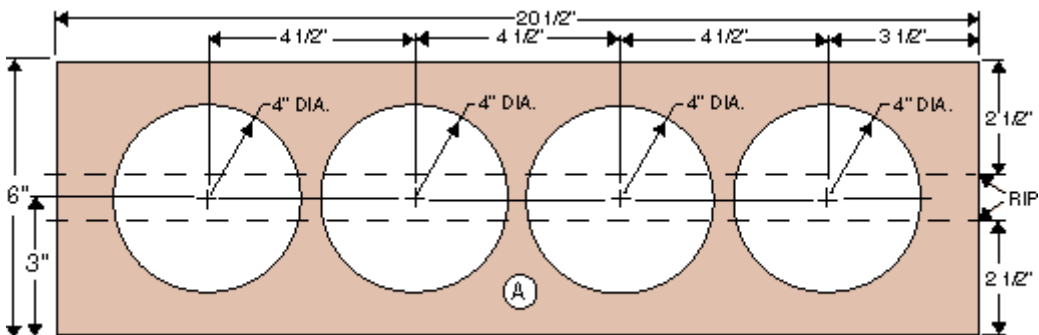

FIGURE 1

Use your Drum Sander to smooth the insides of your circular cut-outs. Set up your table saw or bandsaw rip fence to a width of 2-1/2". Rip cut one 2-1/2" rail from the rail stock. Then turn the same piece of rail stock and rip the second rail from it. Repeat the procedure on the other piece of rail stock to get all four rails.

Cut the two ends (B), following the dimensions on the Bill of Materials. Use your bandsaw, scroll saw, saber saw or disc sander (with coarse paper) to form the 3/4" radii on both ends, as shown in Fig 2.

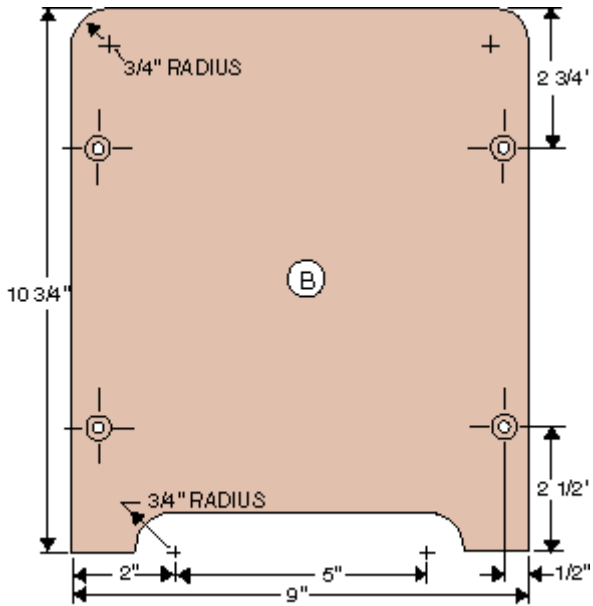

FIGURE 2

Next, using a router and a 1/4" round-over bit, shape all the edges of the rails (A), except for the ends. Use the same bit to shape all the edges of the ends (B), except the bottoms of the feet. Sand all pieces.

Assembly

Locate the positions for the #8 x 1-1/4" flathead wood screws in the ends (B) as shown in Fig 2. Use your drill press to bore a 3/8" diameter x 1/4" deep counterbore at each location. Dry assemble the rack together as shown and clamp it temporarily together using bar clamps or pipe clamps. Use your portable electric drill to bore a 1/8" diameter pilot hole through the sides (B) at the same location and into the middle of the ends of each rail (A).

Assemble the rack using glue and #8 x 1-1/4" flathead wood screws. Cover the screw heads using 3/8" diameter dowel plugs or buttons.

Final Touches

Finish with a stain (if you prefer) and a clear coat of polyurethane or salad bowl finish.

Final Assembly

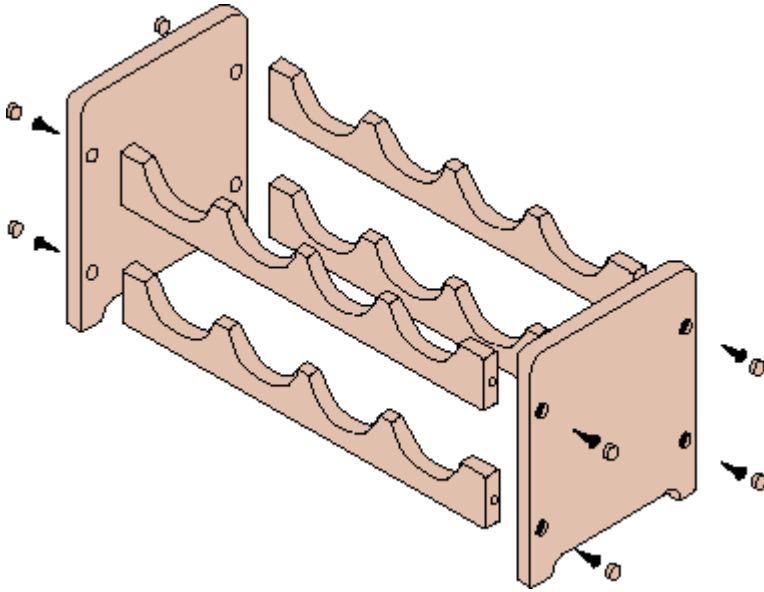

KITCHEN PASTA TOOLS



Here are three great kitchen tools that will take the work and guesswork out of pasta-making -- and serve-up some nice profits at shows and craft fairs, too! Mama Mia! These are some specky-spicy pasta toolios . . . and you don't have to be Italian to appreciate their timeless design, work-saving utility and money-making potential! So . . . who hasn't . . .

Made too much or too little pasta for an important meal?

Watched helplessly as a half-pound of cooked pasta slipped out of the spoon you were transferring it with into a pile on the kitchen floor?

Needed a place to cool a freshly-baked loaf of bread or quickly dry some home-made pasta or noodles ?

These three handsome kitchen tools are the answer. Plus, they're so fast and easy to make that you can afford to sell them at a price your customers will be quick to pay without a lot of thought (they're great "impulse winners") . . . and you'll still make a hefty profit in the bargain.



Spaghetti Measure



Making too much or too little spaghetti will cease to be a problem with this handy kitchen utensil. Just fill the one, two, three or four-serving holes with pasta to get the right amount, every time.

Start by making a stiff cardboard (or hardboard) template of the spaghetti measure pattern as drawn in the Spaghetti Measure Template. Be sure to drill 1/16-inch diameter center-marking holes at each of the five hole locations on your template.

Cut some 3/4-inch x 3-inch x 15-inch pieces of hardwood stock (we used cherry). Using the template you just made, trace the outside shape of the spaghetti measure onto your stock and mark your five hole centers.

Use your drill press and hole saws to bore the 7/8-inch, 1-1/8-inch, 1-1/2-inch and 1-3/4-inch holes in your stock. Don't forget to drill the small, 3/16-inch dia. hanging hole.

Once you've drilled all the holes, use your bandsaw to carefully cut the overall shape and your drum sander to smooth the outside edges. Then go back to your bandsaw to resaw your 3/4-inch stock into two workpieces, about 3/8-inch thick before running each through your thickness planer (or over your jointer) to smooth the surfaces.

Now, use your Router with a 1/4-inch Router Chuck and a bearing pilot, 1/4" round-over Router Bit to round-over the outside and inside edges.

Finishing

We recommend that you use a non-toxic Salad Bowl Finish or other non-toxic finish of your choice for this project.

Pricing

When made out of domestic hardwoods such as cherry, oak or maple, the measure and fork should bring between \$15 and \$20 as a pair and the cooling rack \$15 to \$20 by itself! Make them out of more exotic woods and they'll bring even more. In fact, why not offer a variety?

Spaghetti Measure Template

Actual Size

1 GRID SQUARE = 1/2"

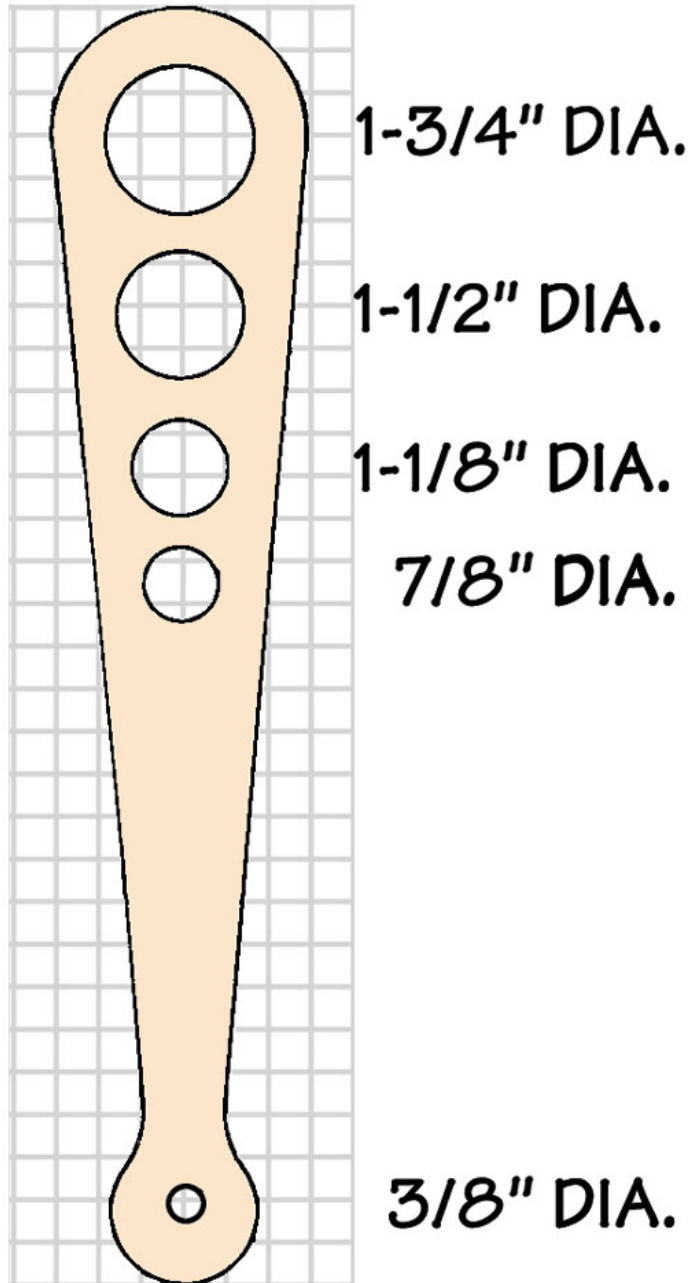



Pasta Fork



Most of us have already discovered that transferring pasta from the pot to the plate with a spoon (or even a cooking fork or pair of tongs) is a risky proposition, at best. Just when you think you've got a grip, you discover that you don't.

As with the Measure, start by making a stiff cardboard (or hardboard) template of the fork pattern as drawn in the Pasta Fork Template. Using the Pasta Fork Peg Template, drill 1/16-inch diameter center-marking holes at each of the 11 hole locations on your template.

There are two ways to make the fork. The first (and most efficient) is to start with a 5/4-inch thick piece of stock, drill all the holes, cut the outside shape, drum-sand them smooth, then resaw your stock to the 1/2-inch thickness before gluing dowels of a contrasting color into the 10 peg holes and sanding the pegs flush on the back side.

The second way is to cut your blanks to shape, drum sand them smooth, resaw them to thickness, then drill the peg holes in the business end of the forks to a depth of 1/4-inch so your dowels aren't visible on the back side.

Once you've chosen your approach and have completed the drilling, cutting-to-shape, sanding and resawing steps, use your Shopsmith Router Package with the 1/4-inch Router Chuck and a bearing pilot, 1/4" round-over Router Bit to round-over all edges. For the pegs, we suggest 1-1/2-inch long pieces, cut from a 1/4-inch dowel rod on the first (through) version -- or 1-1/4-inch long pieces for the second version where the pegs don't go all the way through. In both cases, be sure to use a waterproof glue.

Finishing

We recommend that you use a non-toxic Salad Bowl Finish or other non-toxic finish of your choice for this project.

Pricing

When made out of domestic hardwoods such as cherry, oak or maple, the measure and fork should bring between \$15 and \$20 as a pair and the cooling rack \$15 to \$20 by itself! Make them out of more exotic woods and they'll bring even more. In fact, why not offer a variety?

Pasta Fork Template

Actual Size

1 GRID SQUARE = 1/2"

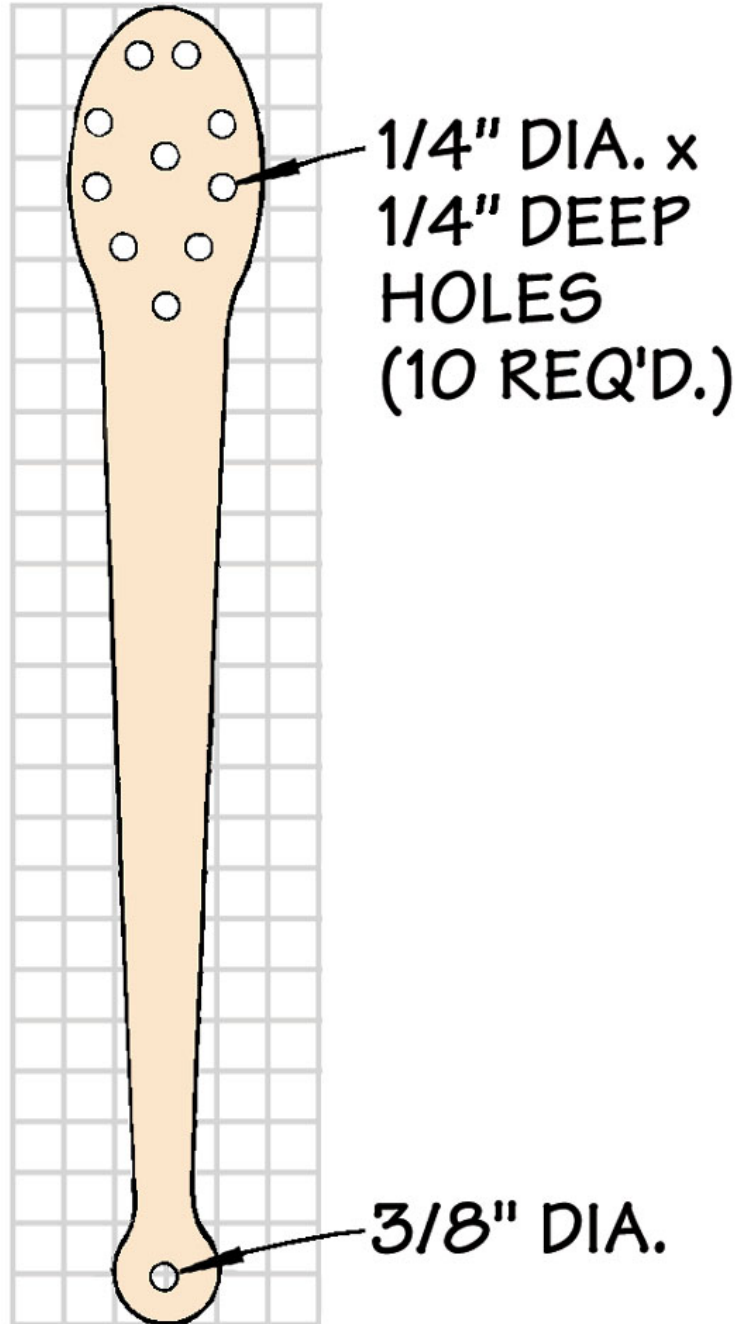

Pasta Fork Peg Template

Hole Pattern at left Actual Size

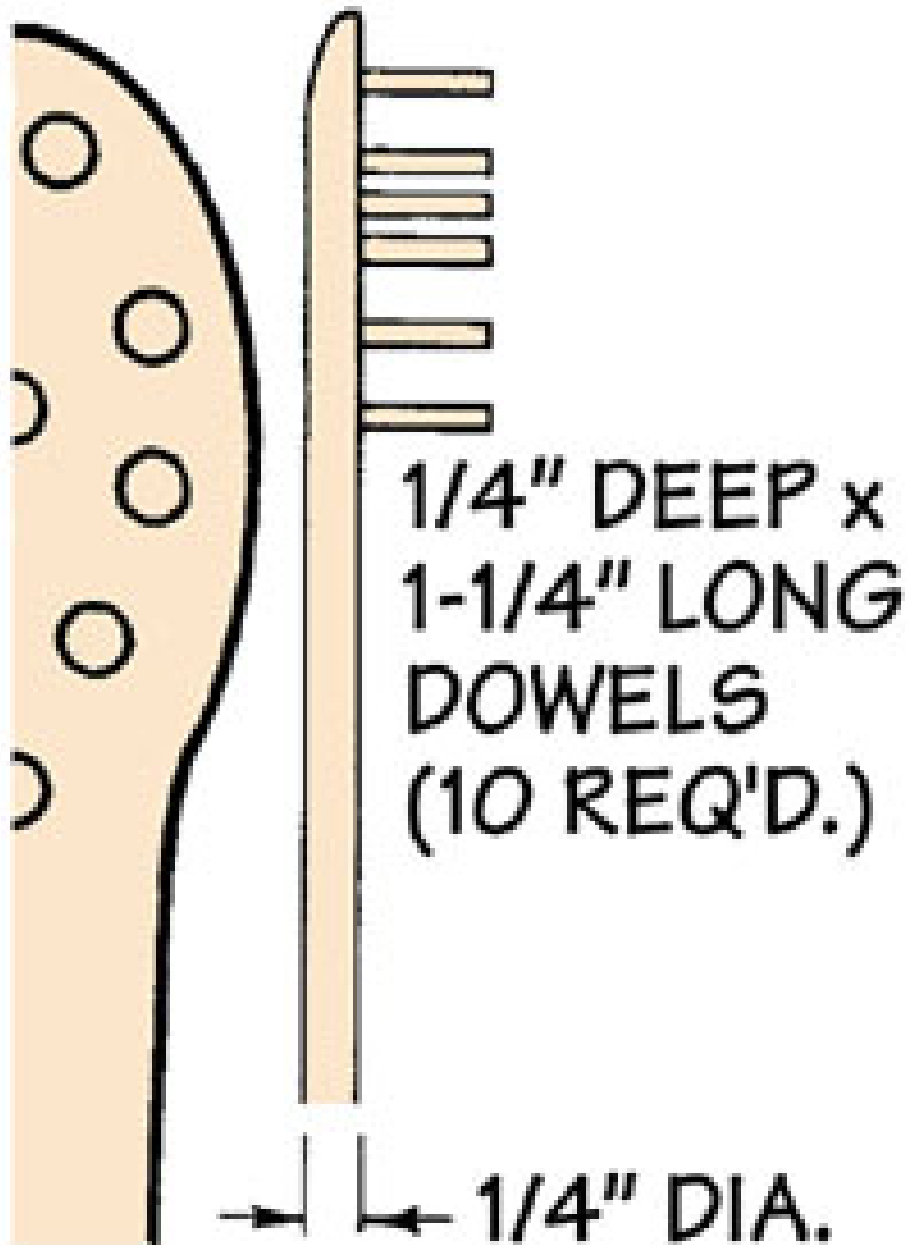



Cooling Racks



Few projects are easier to make than these Cooling/Drying Racks. Just two strips of wood, joined together by a series of dowels. Start with pieces of 3/4-inch thick stock, 8-inches or 16-inches long and ripped to 2-3/8-inches wide (this will make four 1/2-inch thick sides).

Set up your drill press with a 3/8-inch brad point bit. Lay a 2-inch to 3-inch wide piece of scrap stock on your drill press table surface, up against your rip fence. Attach a piece of masking tape to the face of your rip fence where it meets your scrap stock. Using a pencil, draw index marks on the tape that you'll use to position your stock for making each of the 16 (or 8) dowel holes.

Be sure your table and drill bit are perpendicular. Set your workpiece on edge and adjust your quill stop so it drills all the way through the 2-3/8-inch width of the stock and barely into your scrap stock. Drill all the holes as shown by the Assembly Drawing.

Once you've drilled all your holes, use your table saw (with appropriate push sticks, etc.) to slice off the 1/2-inch thick sides you'll be needing. Then, run them over the jointer to smooth the faces and sand all the edges smooth before gluing the dowels into position with a waterproof glue. Once the glue has dried, sand the dowels off flush.

Finishing

We recommend that you use a non-toxic Salad Bowl Finish or other non-toxic finish of your choice for this project.

Pricing

When made out of domestic hardwoods such as cherry, oak or maple, the measure and fork should bring between \$15 and \$20 as a pair and the cooling rack \$15 to \$20 by itself! Make them out of more exotic woods and they'll bring even more. In fact, why not offer a variety?

Cooling Rack

Assembly Drawing

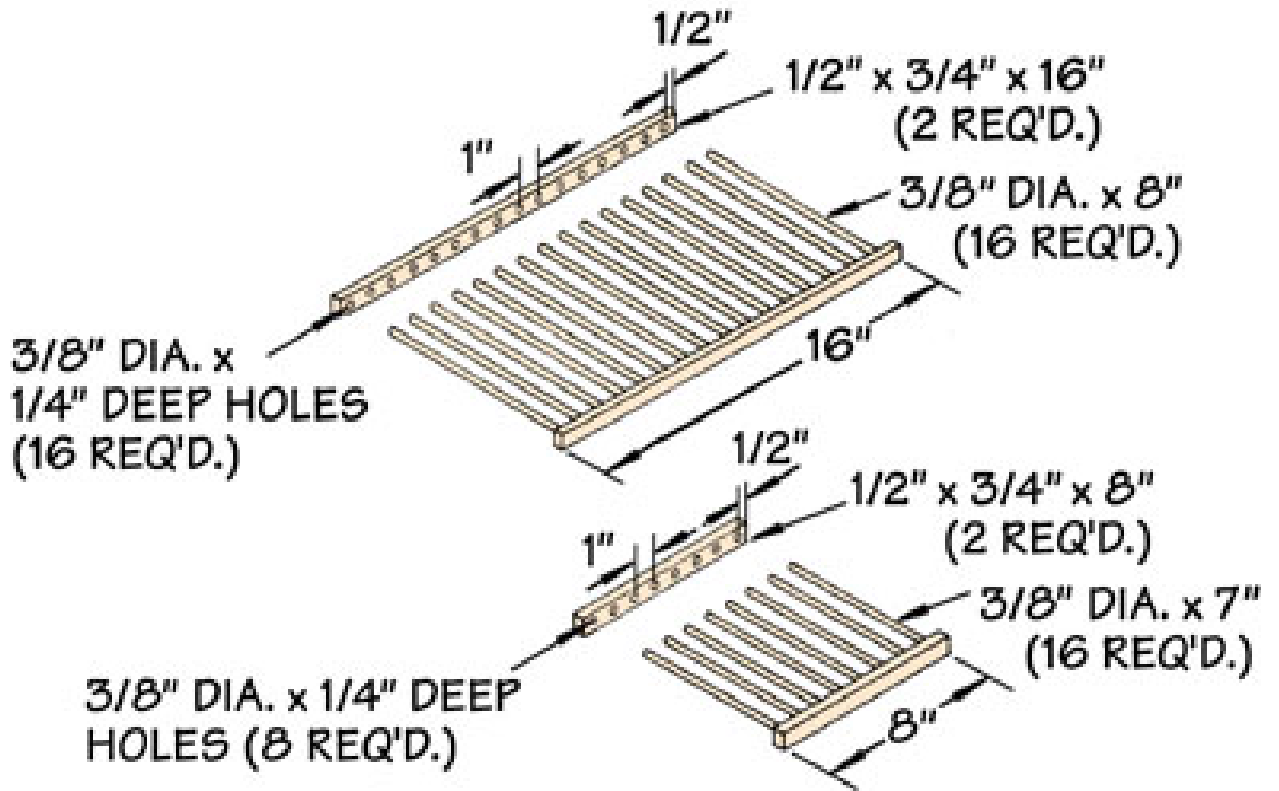

PECKING CHICKENS



Old-fashioned toys -- particularly animated ones -- have been delighting children of all ages for generations . . . and these Pecking Chickens are certainly no exception! Just swing the toy in a horizontal, rotary motion and watch in amazement as each of the four chickens pecks, in order, at the seeds in the center of the paddle. This animated action, coupled with the pecking sound it makes during play, makes this toy an easy sale at craft fairs, flea markets and art shows.

If you're making a quantity of these toys to sell (and you own a bandsaw), we recommend that you use a pad sawing technique, where you temporarily affix a stack of workpiece blanks together . . . saw out several parts at the same time . . . then separate them. Double-stick tape is the best choice for holding everything together nicely during cutting, then separating easily when you're finished.

1. Start by cutting out the paddle(s) with your bandsaw, scroll saw, sabre saw or coping saw.
2. If you're using a pad sawing technique, leave the pieces attached together while you use your drill press to bore the (8) holes in the paddle(s) according to the Paddle Layout.
3. Next, separate the paddles (if you're pad sawing more than one at a time) and use a countersink to bevel both the tops and bottoms of the 1/8-inch holes (not the 1/4-inch holes) in the paddle(s). This is done so the strings won't snag or wear thin from rubbing on the sharp hole edges.



4. Round over the sharp edges of the paddle(s) lightly with sandpaper.
 5. In the end grain of some 3/4-inch thick chicken body stock, cut a 1/4-inch wide x 5/16-inch deep saw kerf with your dado blade. This kerf will form the hinge in the body of the chickens that allows the head to pivot. Be sure to lay out the chicken bodies in a way that puts the kerfs at an angle, as shown in the Chicken Body Layout, so the chicken heads tilt forward slightly during play.
 6. If you're pad sawing multiples at the same time, attach your blank workpieces together and cut out the chicken bodies. Once sawn, separate the bodies and drill your 1/4-inch dowel holes in the bottoms.
 7. Next, cut out the chicken heads from 1/4-inch thick stock. Separate the heads (if pad sawing multiples) and drill the 1/16-inch diameter holes for the #18 brad hinge and the string, as shown in the Chicken and Head Assembly. The brad pivot hole is drilled all the way through from side-to-side -- while the string mounting hole is drilled only about 1/4-inch deep from back-to-front.
 8. Attach the strings to the heads by threading their ends into the head holes and gluing them in position with a toothpick wedge (broken off flush) to hold them firmly. Hinge each head to a body with a #18 brad. Be sure to allow enough room for the string to slide. You may have to sand the sides of the heads slightly before assembly so they pivot freely in the body kerf.
 9. Mount the chicken bodies to the paddle with 1/4-inch dowels.
 10. Feed the strings through the countersunk holes in the paddle(s) and fasten them to a bead, as shown, using a small wedge to hold them tightly in position.
- NOTE: Be sure all strings are the same length so they pull equally. Attach a weight (hardwood ball or lead fishing weight) to the bead.
11. Glue the seeds in the center of the paddle, close enough for the chickens to peck at, but not actually hit.
 12. Paint or apply an oil finish, as you prefer.

Suggested Retail Price: \$15 to \$20

The Pecking Chickens

Chicken Body & Head Assembly

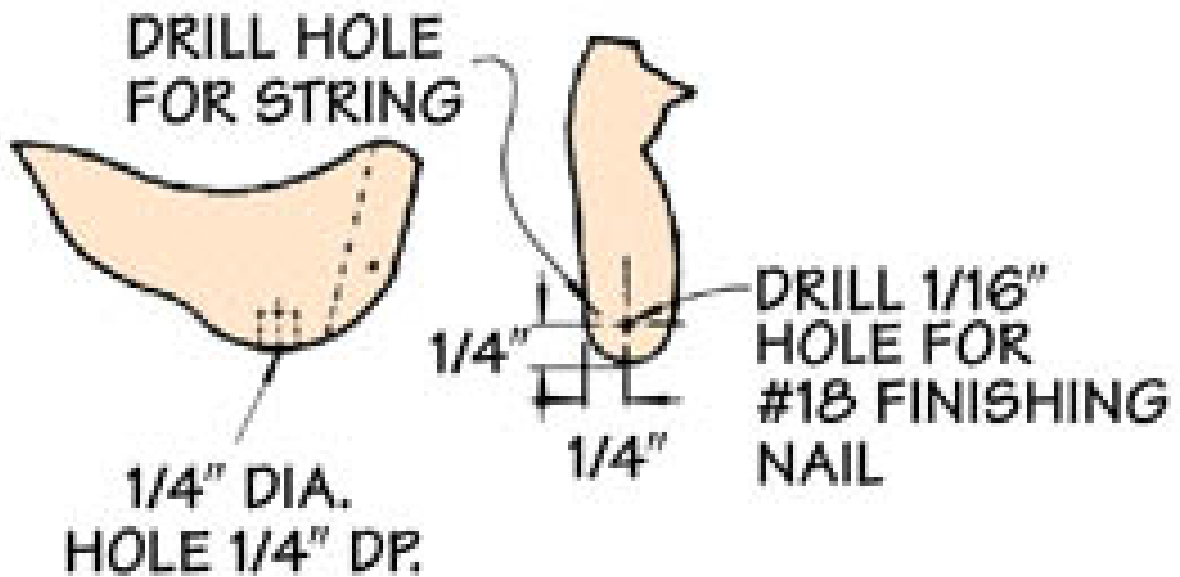

The Pecking Chickens

Chicken Body Layout

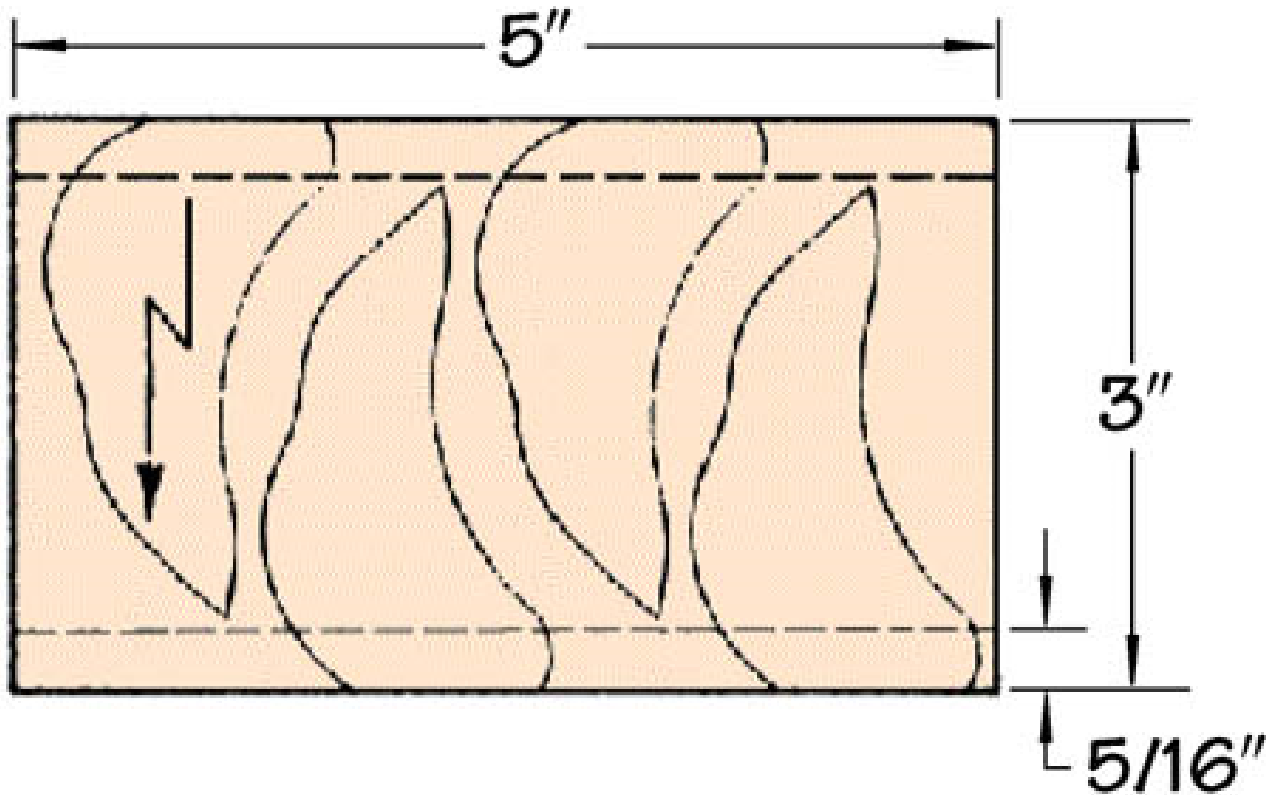

The Pecking Chickens

Paddle Layout

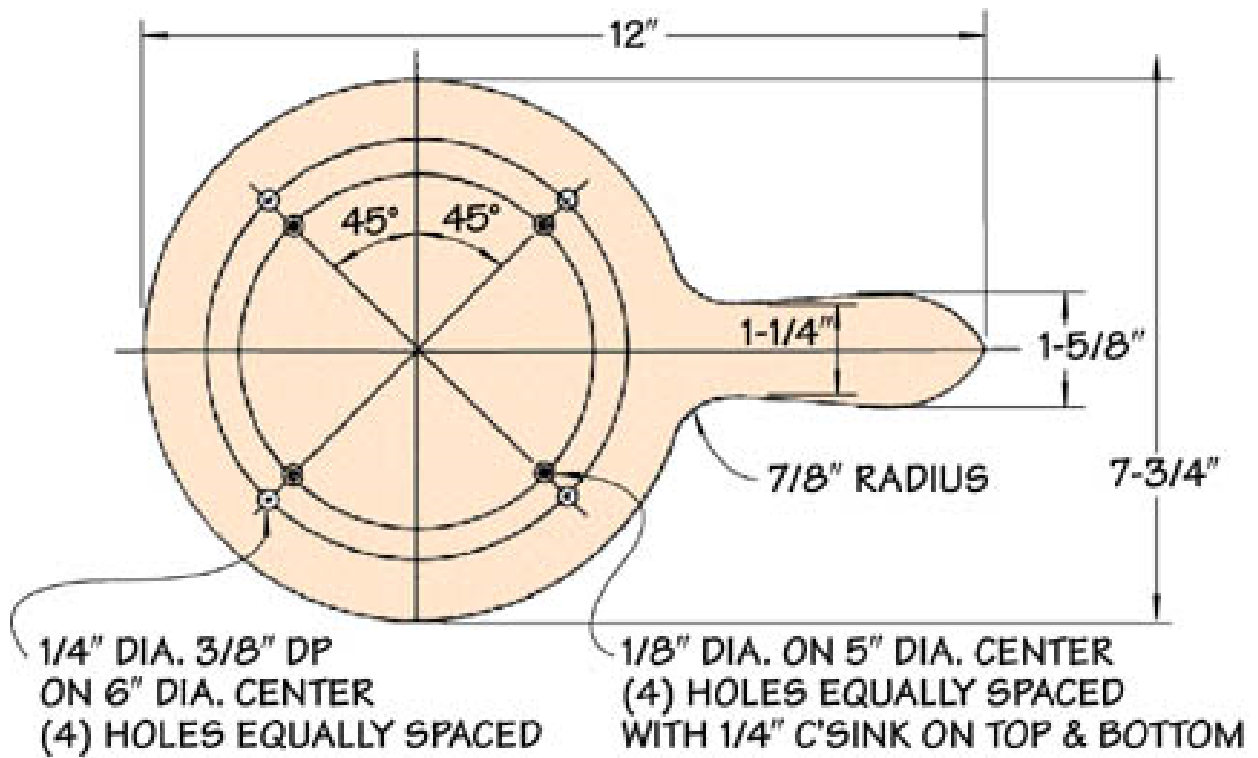

The Pecking Chickens

Final Assembly

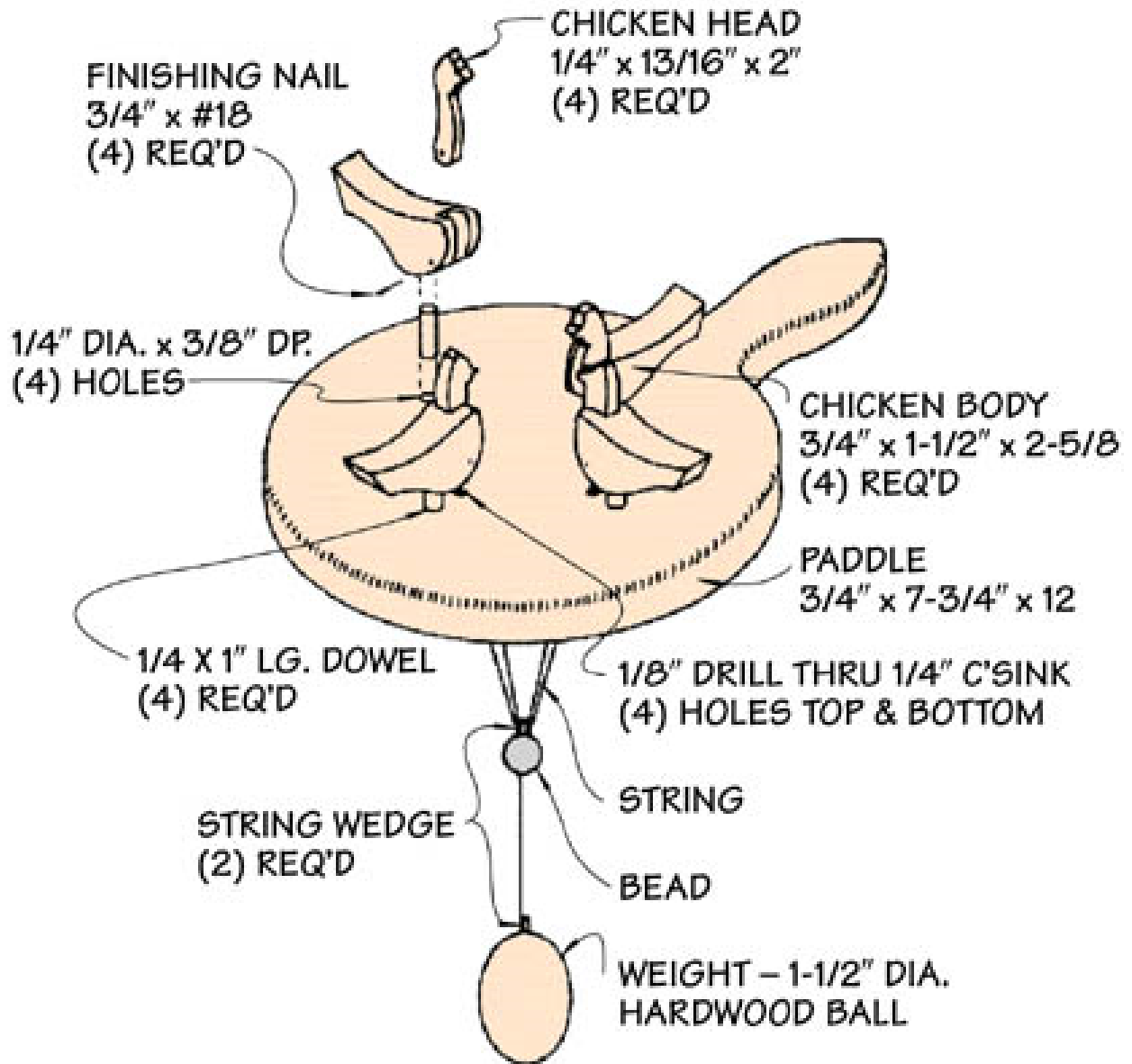

GOURMET BIRD FEEDER



Here's a large, unique designed feeder that's a pleasure to look at -- PLUS -- it gives visiting *lucky birds* their choice of four seeds!

If you're a lover of nature, you'd probably agree that the more species of birds you can get to visit a bird feeder in your yard, the happier you'll be. If that's the case, here's a uniquely designed feeder that you can load with up to four different types of seeds to bring a variety of birds within easy sight. Just match the birds you choose to attract with the seeds they prefer to eat. We've even provided a brief table of seed types at the end of this article to help you make the right choices.

How To Build It

Because it's so attractive and should last outdoors indefinitely without any type of finish, we built our Gourmet feeder out of redwood. However, any durable, weatherproof wood such as Western red cedar or cypress would also be fine...though we would not recommend the use of pressure-treated lumber, due to its toxicity. The main body of our feeder is made from 3/4" stock, while the windows (J) compartment dividers (K) and edging (M) are cut from 1/4" plexiglass or similar see-through plastic material.



Start by cutting the four end pieces (A,B), deflectors (C), bottom (D) and the roof rafter (E) to length. Follow the pattern in the drawings and use your bandsaw or scroll saw to form the shapes on the ends (A,B). Next, rout the 1/4" grooves in the end pieces (A) to accept the front and back windows (J). Drill the 1/2" dia. x 3/8" deep holes for the dowel perches (H) in the end pieces (A). Rout a 3/8" deep x 3/8" wide rabbet on the OUTSIDE TOP edges of the bottom end pieces (A) -- and the INSIDE BOTTOM edges of the top end pieces (B). These rabbets help to create a weatherproof seal when the feeder is assembled. You'll need to square the rabbets on the top end pieces (B) with a chisel.

Tilt your saw table to 45 degrees and cut the beveled edges of the deflectors (C) to form the pyramid-shape that will keep the seed moving down into the feeder. Use some small brass or copper brads and weatherproof glue to assemble these two pieces together, then attach the assembly to the bottom using brads. Adjust your saw table to a 30 degree tilt and bevel the top edge of the roof rafter (E).

Using five #8 x 1-1/4" brass, flathead wood screws on each end, attach the lower ends (A) to the bottom and ends of the deflectors, as shown in the drawing (DON'T insert the perches, yet). Slip the front and back windows (J) into the grooves in the end pieces (A). Attach the upper ends (B) to the roof rafter (E) with flathead wood screws and weatherproof glue and set the assembly aside.

Cut the remaining plastic parts (K,L,M) using your bandsaw or scroll saw. Drop the compartment dividers (K) into position in the feeder, spaced evenly along its length. Using a 1/8" plexiglass drill bit (They're available at most hardware stores and home centers and have a sharp pointed tip to prevent breakage when drilling plastics.), VERY CAREFULLY drill through the windows (J) and into the edges of the compartment dividers to a depth of about 9/32". Use three 1/2" x #4 brass roundhead wood screws to attach each window (J) to each side of the three compartment dividers (18 screws, total). Be very careful when tightening these screws to avoid breaking the plastic dividers (K).

Align the feed dividers (L) with the compartment dividers and carefully drill your 1/8" pilot holes through the 1/4" tab at the tops of the feed dividers (L) and into the windows (J). Attach the tops of the dividers to the windows (J) using six of the same small screws. Position an edging piece (M) on each side of the feeder. Drill four evenly spaced pilot holes through the bottoms of each edging piece (M) for screwing these pieces to the edges of the wooden bottom (D). Be careful not to drill into your wood so your screw tips will get a better grip. Next, drill a pilot hole through the edging pieces (M) and into the edges of the feed dividers (L) where these pieces meet. Using 6 more 1/2" x #4 brass roundhead screws, attach the edgings (M) to the feed dividers (L). Loosen the screws holding one of the lower ends (A) to the bottom (D), slip the perches into position and re-tighten.



The final step is to cut the 18 roof shingles (F). Tilt your table saw or bandsaw table to 7 degrees and carefully resaw the 2-1/8" wide x 3/4" thick pieces into the angles shingles as shown in the detail drawing. Overlap the shingles and fasten them to the upper ends (B) and roof rafter (E) with brass or copper brads. Tilt the table on your table saw to 30 degrees and cut the inside V on the edge of a wide board for the weather cap (G). Move your rip fence in toward the blade 1/2" and cut another V. Tack the cap (G) into place and attach window sash locks to the ends (A,B) to hold the top of the feeder to the bottom. Mount your feeder to a post...or hang it from a branch with a chain or cable through a screw-eye or eye bolt that's attached to the roof rafter (E).

Gourmet Bird Feeder

Layout View

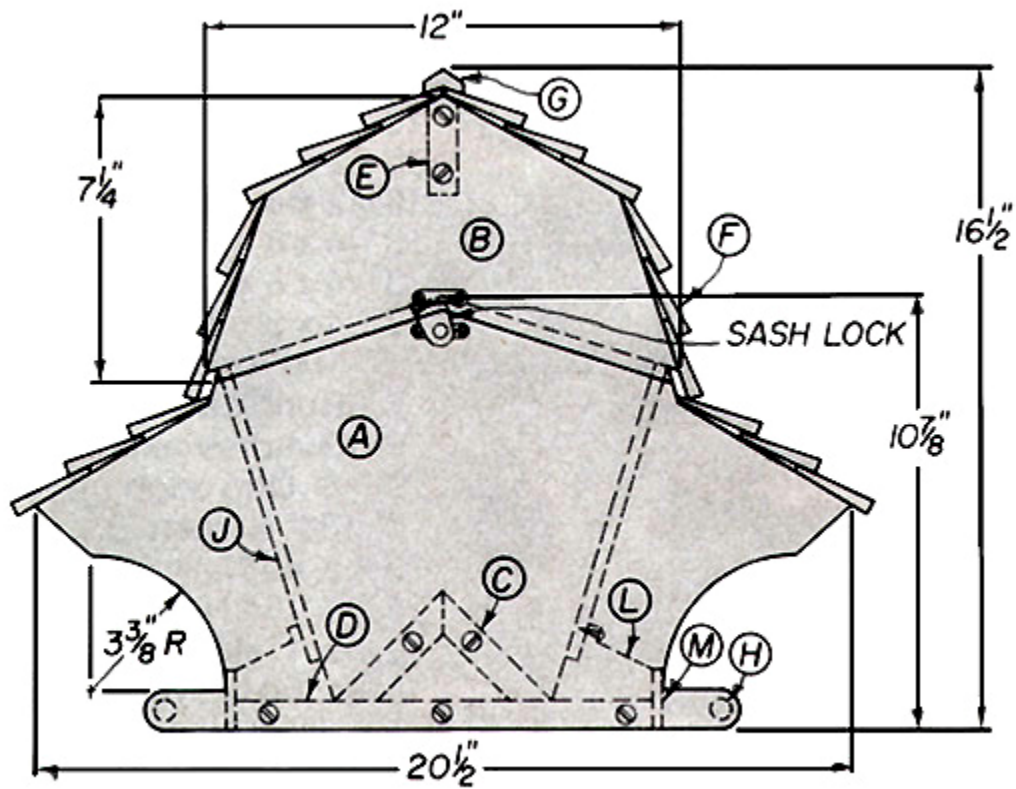

LAYOUT

Gourmet Bird Feeder

"A" View

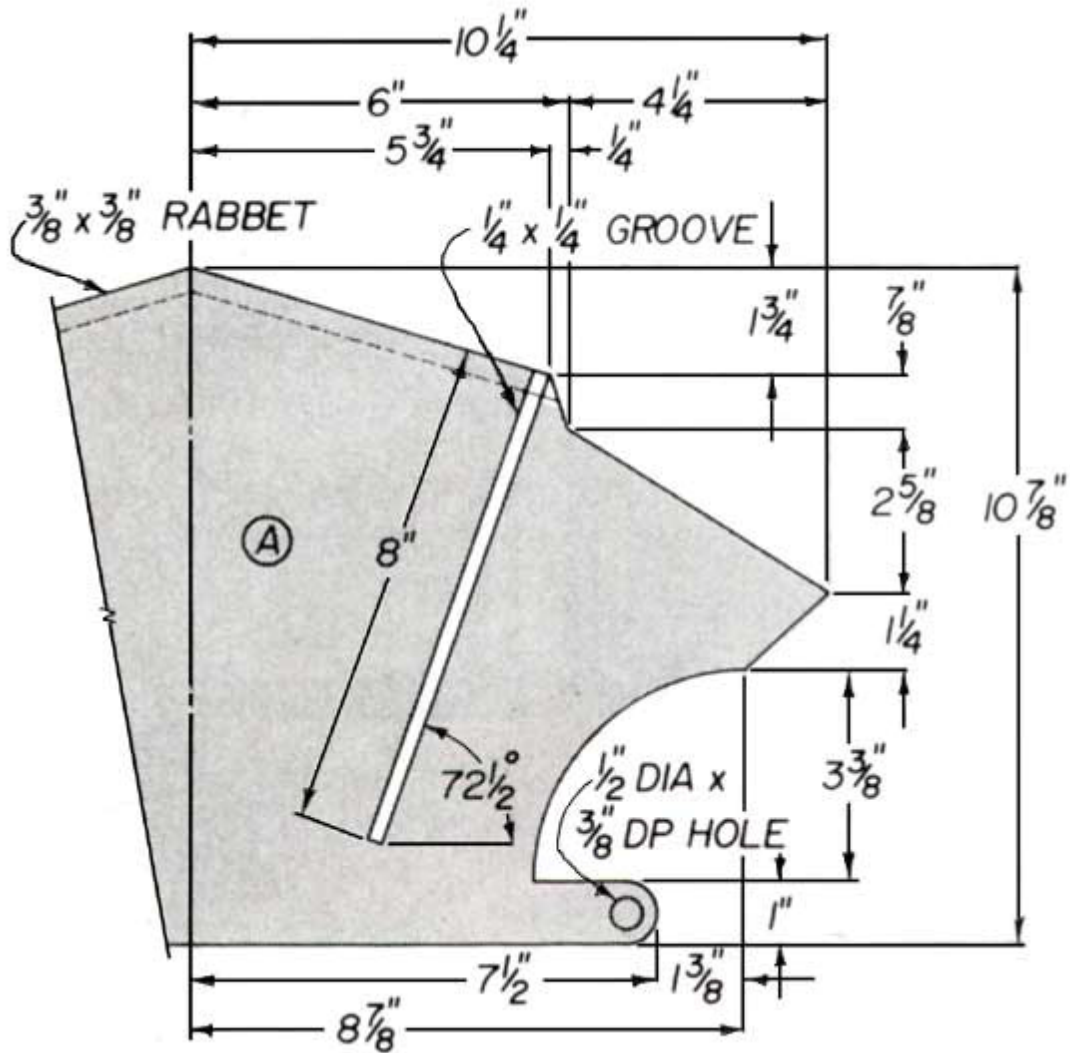

Gourmet Bird Feeder

"B" View

[List of Materials](#)

[Back to Instructions](#)

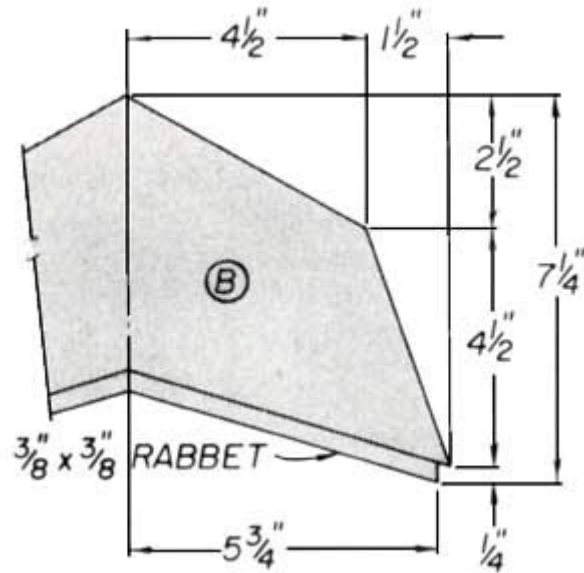

Gourmet Bird Feeder

"F" View

[List of Materials](#)

[Back to Instructions](#)

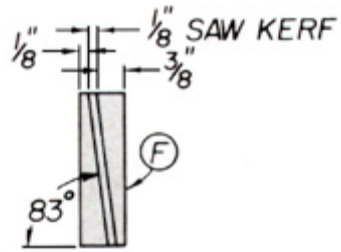

Gourmet Bird Feeder

"K" View

[List of Materials](#)
[Back to Instructions](#)

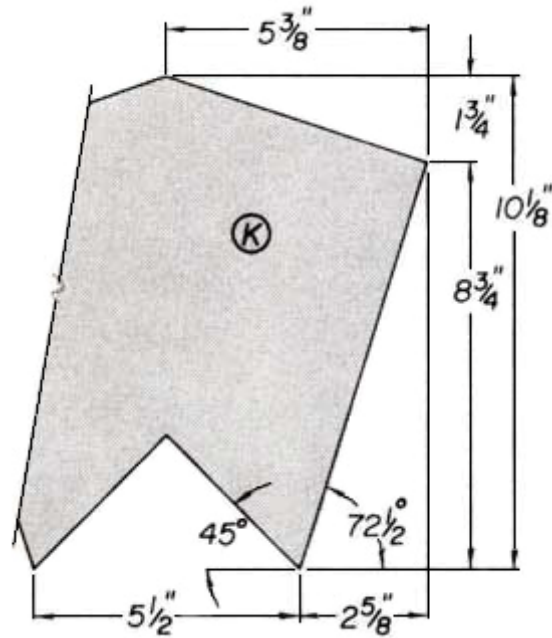

Gourmet Bird Feeder

"L" View

[List of Materials](#)

[Back to Instructions](#)

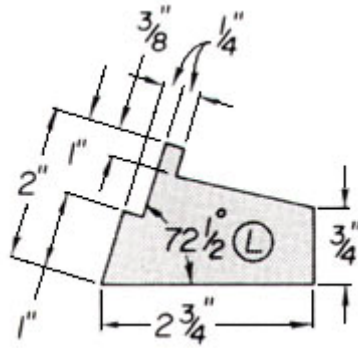



BILL OF MATERIALS
(finished dimensions in inches)

A	Lower ends (2)	3/4 x 10-7/8 x 20-1/2
B	Upper ends (2)	3/4 x 7-1/4 x 12
C	Deflectors (2)	3/4 x 3-7/8 x 22
D	Bottom	3/4 x 10-1/2 x 22
E	Roof rafter	3/4 x 2-1/2 x 22
F	Shingles (18)	3/8 x 2-1/8 x 27-1/2
G	Weather cap	1/2 x 3/4 x 27-1/2
H	Perches (2)	1/2 dowel - 22-3/4 long
J	Windows (2)	1/4 x 7-1/2 x 22-1/2 plastic
K	Compartment dividers (3)	1/4 x 10-1/8 x 10-3/4 plastic
L	Feed dividers (6)	1/4 x 1-7/8 x 2-3/4 plastic
M	Edging (2)	1/4 x 1-1/2 x 22 plastic

HARDWARE

- (14) #8 x 1-1/4" flathead, brass wood screws
- (38) #4 x 1/2" round head brass wood screws
- (56) 3/4" brass or copper brads
- (2) brass sash locks

SEED PREFERENCES OF DIFFERENT BIRDS

Black oil sunflower seeds	Blue jays, cardinals, chickadees, finches, grosbeaks, mourning doves, nuthatches
Cracked corn	Blue jays, cardinals, mourning doves, sparrows, starlings, woodpeckers
Thistle	Buntings, finches, redpolls, siskins
White millet	Blackbirds, cowbirds, grackles, juncos, sparrows, starlings



2002 Archive



THE WORKSHOP TOOLBOX

Nine drawers of storage in this 2-piece toolbox give you a place for everything

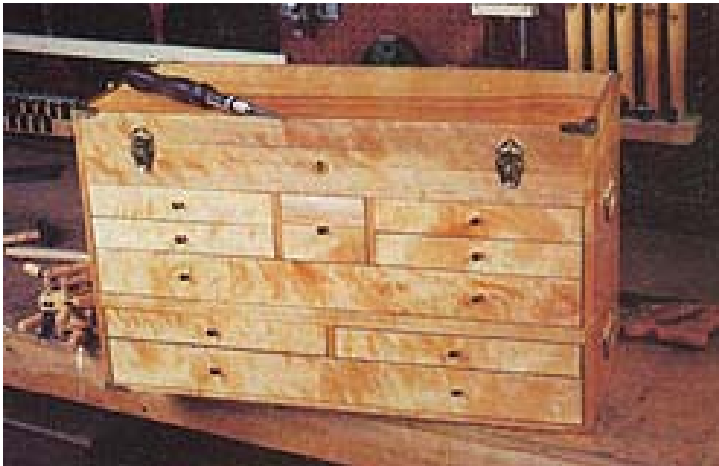

This workshop toolbox features a total of nine drawers to hold all types of hand tools and small accessories for your MARK V and portable electric tools. It's made in two sections...a top with a large upper compartment and six drawers, and a base with three drawers. Since it's a two-part project, you can either make the entire tool box all at once, or you can split the job into two sessions, building part now and part later.

We built our box out of solid birch and birch plywood. We used poplar for the drawer sides and backs and 1/8" pegboard for the drawer bottoms.

Step 1: If you have a thickness planer, start by gluing up a 12-1/2" wide by 42" long piece of stock for the box sides (A) and base sides (N). The extra width and length will give you enough stock to allow for your saw kerfs and for squaring-up your planed stock. Once the glue has dried, use a hand scraper or bench chisel to carefully remove any glue squeeze-out before planing the stock to its desired 1/2" thickness. Next, rip your stock to the final 12" width, then crosscut the pieces (A & N) to 12-3/16" and 6-1/16" (1/16" longer than their indicated finished lengths).

If you don't have a thickness planer, start by resawing your narrow pieces of stock to 9/16" thick. If you have a jointer, rip them to a dimension that's narrower than your jointer blades are wide, then make two 1/64" passes across each face, bringing the individual pieces to the desired 1/2" thickness. Next, rip the edges of your stock parallel, joint them on your jointer and glue them up to the 42" x 12-1/2" size, as described above. Use



a belt sander to carefully sand off any imperfections where the boards are joined. Next, rip your stock to the final 12" width, then crosscut the pieces (A & N) to 12-3/16" and 6-1/16" (1/16" longer than their indicated finished lengths).

Follow the same procedures outlined above to prepare the remaining pieces of thinned-down hardwood and poplar for the project, bringing each to the desired thickness.

Step 2: Cut all parts to size, according to the Bill of Materials by first ripping all stock to width, then crosscutting to length. Joint 1/32" off each end of pieces A & N to bring them to final dimension (See page 76 in Shopsmith's *Power Tool Woodworking for Everyone* textbook for the proper technique).

IMPORTANT NOTE: You will notice that the height of the box sides (as shown in the **BOX SIDE LAYOUT** drawing) is indicated as being 12-1/8" -- and the height of the finished box (as shown in the **FRONT LAYOUT** drawing) is shown as 12". Both of these dimensions are correct. The additional 1/8" is necessary to allow for the saw kerf when sawing lid from the box in step 17, below.

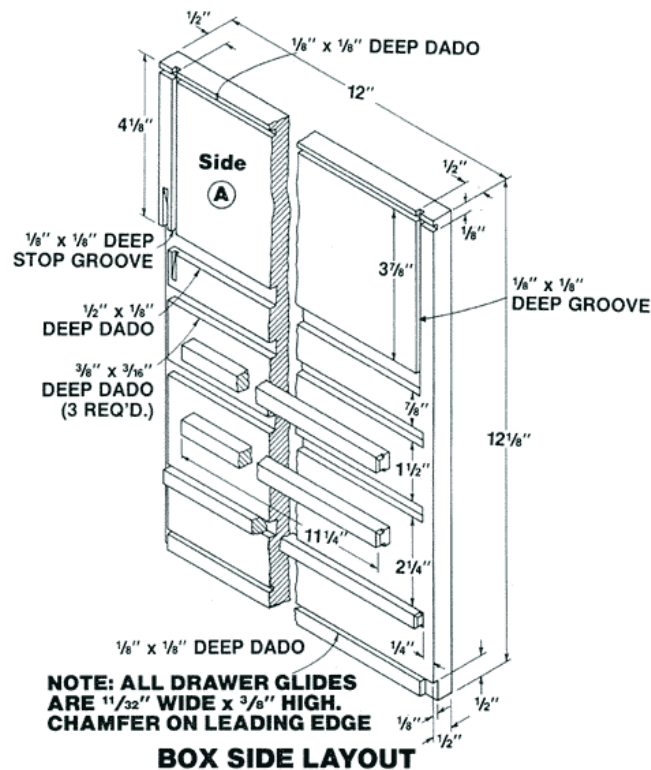

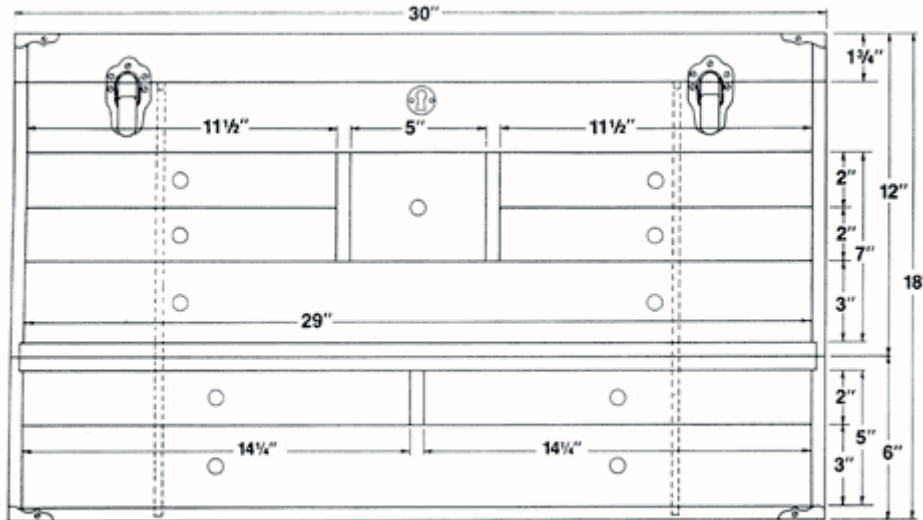

FRONT LAYOUT

Step 3: Cut the 3/8" wide by 3/16" deep stop dados for the drawer glides (F & R) in the sides (A & N), and partitions (J & T), using a 3/8" router bit in the MARK V Router set-up. See Fig. 1.

***NOTE:** Dados are cuts made across the grain of the wood -- Grooves are cuts made with the grain of the wood.*

Next, change to a 1/2" router bit and use the same set-up to rout the 1/2" wide by 1/8" deep stop dados in the sides (A) to accept the compartment bottom (G).

Step 4: Cut a 1/8" wide by 1/8" deep stop groove on the upper part of the sides (A). These grooves will accept the front and back faces (B & C). *Tip:* Use a table saw blade that makes a 1/8" wide kerf to cut these grooves. Chisel the bottom of the groove to depth for the front face (B) **See BOX SIDE LAYOUT** drawing for detail.

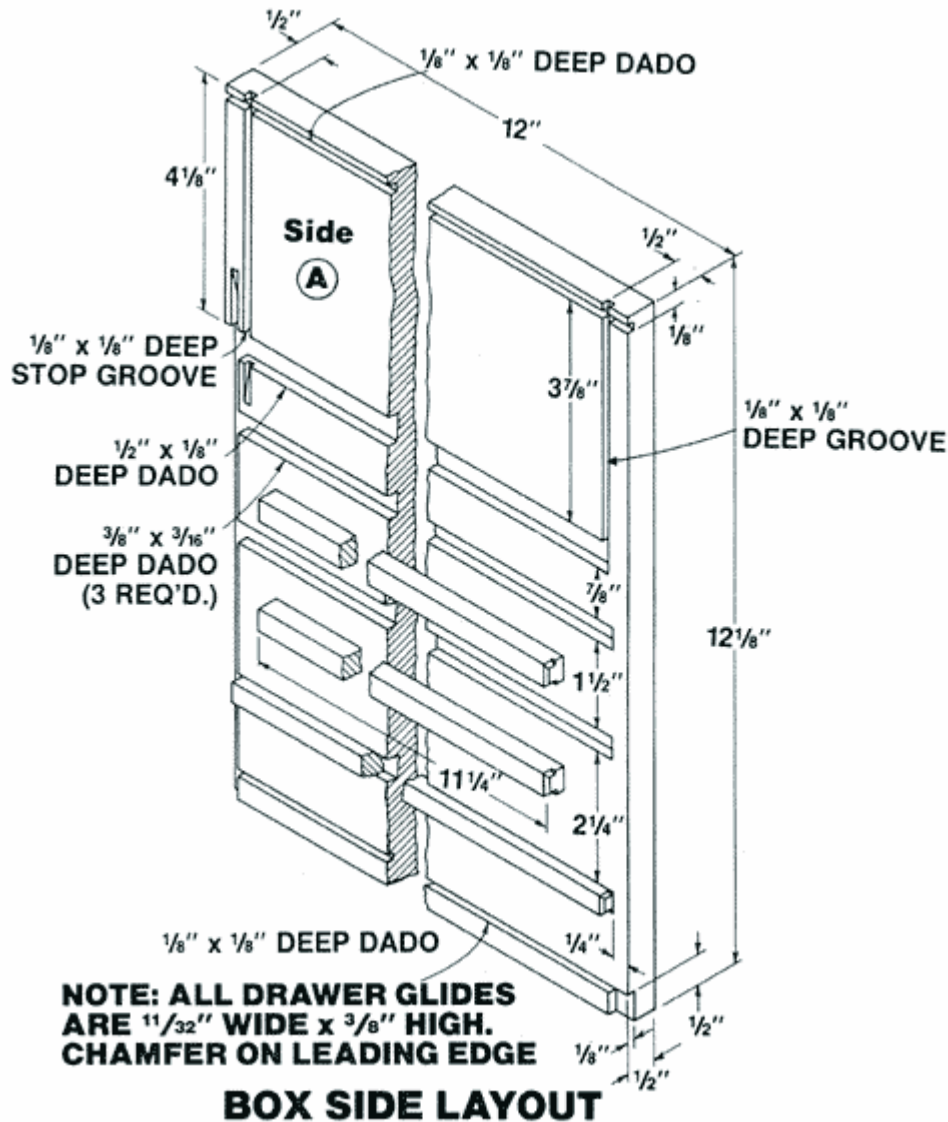

Cut the 1/8" wide by 1/8" deep dados for the tops and bottoms (H,K,S) in the sides (A & N). Cut the 1/8" wide by 1/8" deep grooves at the top and bottom of the front face (B) and the top only of the back face (C).

Cut the grooves in the backs of the sides (A & N) that will accept the (1/8" x 1/8") tongues on the ends of the backs (L & U). The grooves in the box sides (A) are stop grooves, while those in the base sides (N) run from end-to-end.

Complete the groove and rabbet joints in the back edges of the sides (A & N). See **BASE SIDE LAYOUT** drawing for detail.

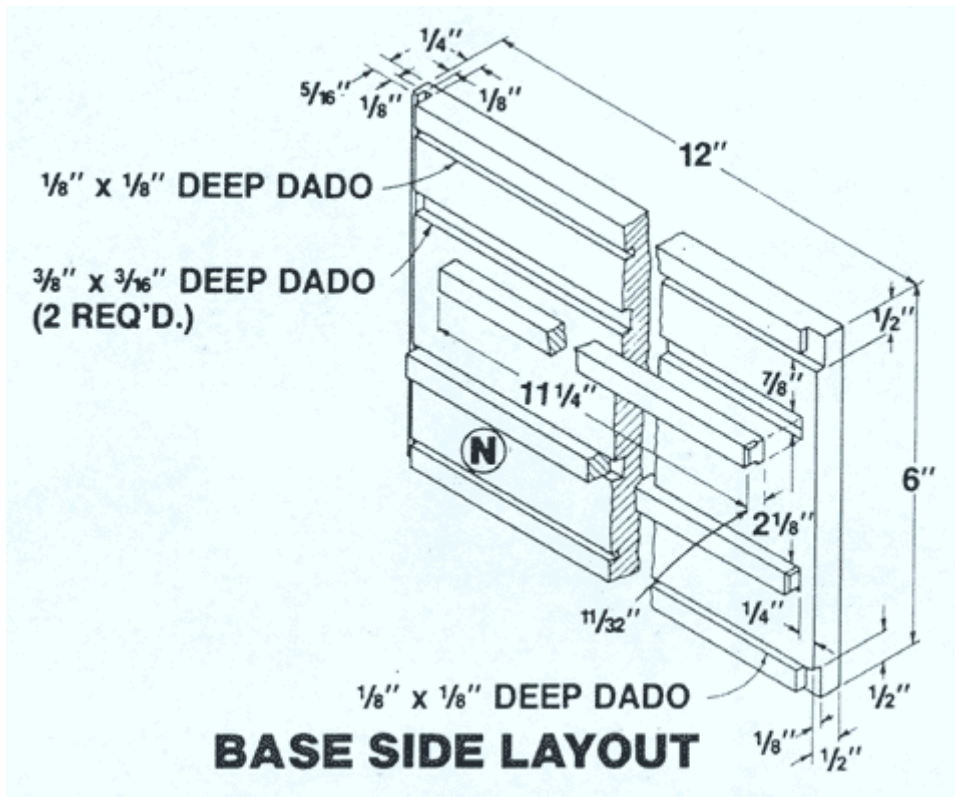

Step 5: Form the 1/8" by 1/8" tongues on the ends of parts B, C, H, L, S & U as shown in the exploded view. Next, form a 1/8" x 1/8" tongue along the front top edge of part G. Form a 1/8" x 1/8" tongue along the front and back bottom edges...and across the bottom edge of each end of part K.

Step 6: Cut 1/2" wide by 1/4" deep dadoes in the undersides of the compartment bottom (G) and the base top (S) to accept the drawer partitions (J & T). See **the DRAWER PARTITION LAYOUT** for details. Use your dado accessory to create these dadoes.

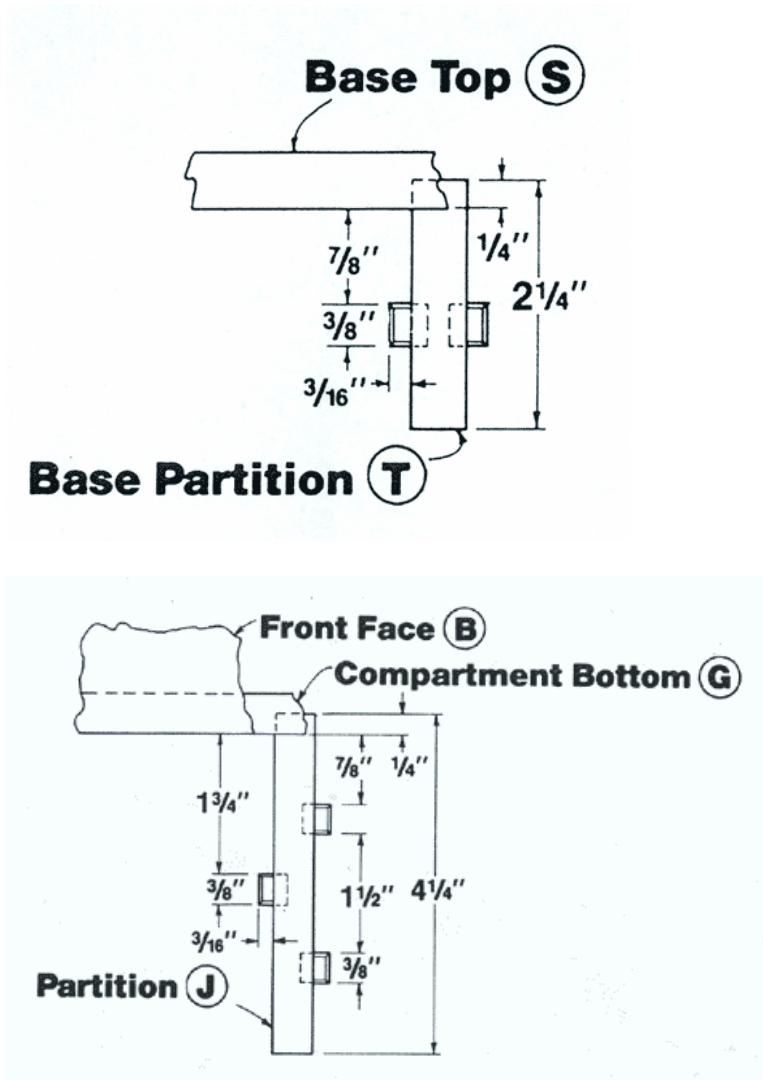

Step 7: Drill the box bottom (H) and base top (S), then counterbores to accept the T-Nut fasteners that will hold the main box to the base. To ensure proper alignment, clamp the two pieces together and drill both at the same time. A total of four T-Nuts will be required and each should be positioned about 2" in from the ends, fronts and backs of pieces H & S. Exact positioning is not critical, as long as all four holes align when drilled.

Drill the 1/4" by 2-3/4" deep locking rod holes in the front face (B) and the front trim pieces (E & P)...centered from front-to-back (**See FRONT LAYOUT and TYPICAL DRAWER CONSTRUCTION** drawings for detail). The holes in pieces B, E, & P must align perfectly so the locking rods can slide freely into position. You'll drill the mating holes in the drawer fronts later.



NOTE: The locking rod hole in the bottom front trim piece (P) should be a stop hole, going only half-way through piece P.

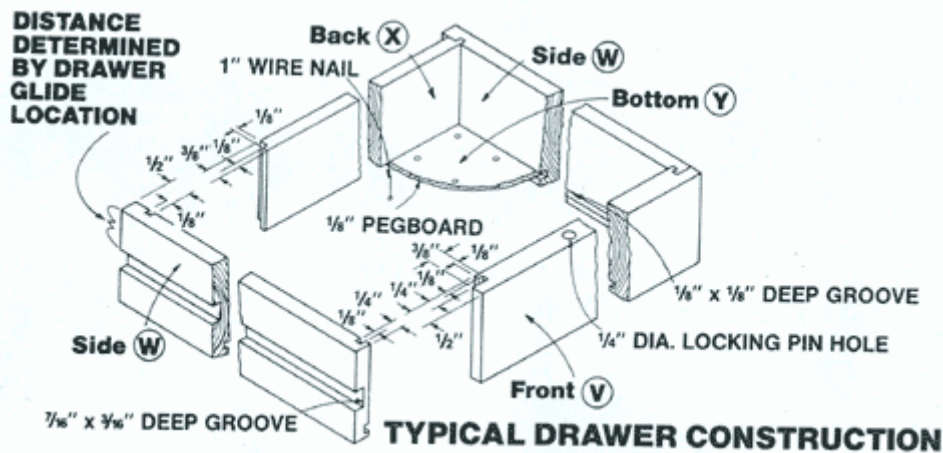

Step 8: Assemble drawer partitions by first gluing the trim pieces (D & Q) to the fronts of the partitions (J & T). Glue the trim pieces (E & P) to the fronts of pieces H & S. Sand all trim pieces flush with the plywood. Glue all of the drawer glides (F & R) into the partitions (J & T) and the sides (A & N), as shown in the drawings. Be careful to remove all excess glue squeeze-out.

Step 9: Chisel out the rabbets that will accept the trim strips (E & P) in the top and bottom of the base sides (N)...and in the bottom of the tool box sides (A). Chisel out the notches for the partitions (J & T) in the lower edge of the front face (B) and the front trim strip (P). **See PARTITION ASSEMBLY detail.**

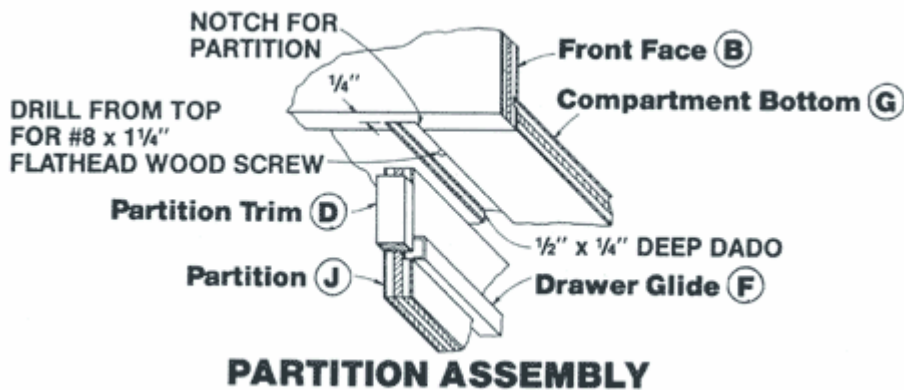

Step 10: Attach partition assemblies into the compartment bottom (G) and base top (S), using glue and #8 x 1-1/4" flathead wood screws. **See PARTITION ASSEMBLY detail.**

Step 11: Dry assemble the box. (NOTE: The lid will be cut from the box later) Working with the box upside-down, clamp the front and back faces (B & C) to the top (K)...then clamp the box sides (A) to this assembly. Slide the compartment bottom/partition assembly in from back -- and slide the bottom (H) in from the front.

Insert the back (L) from the bottom. Remove the clamps from the top to clamp the box sides (A) to the bottom (H). Turn the box right-side-up and check for squareness and fit.

For final assembly, allow the glue to set up on the top (K), front (B) and back (C) faces...then assemble the box sides (A) and bottom (H) to the top assembly before continuing with the assembly.

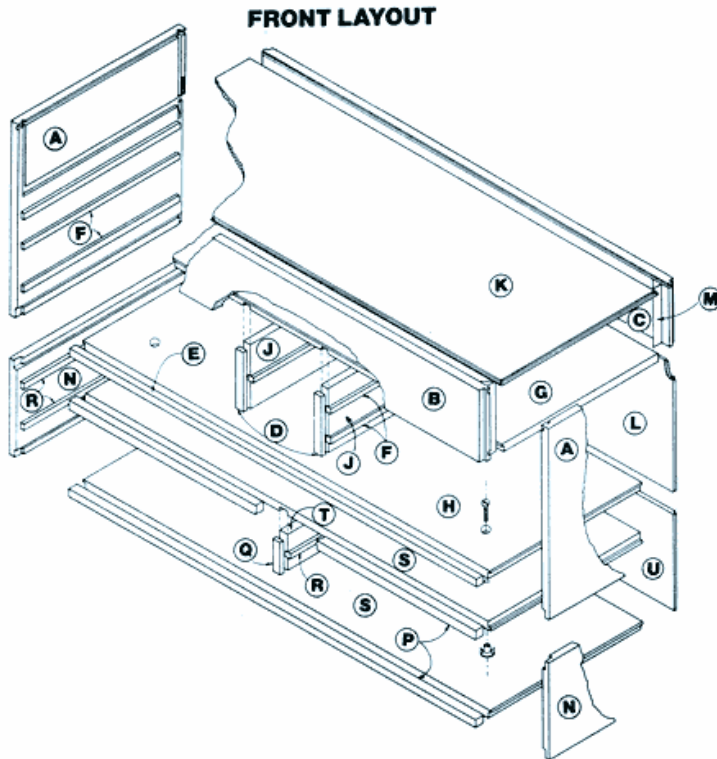

Glue the four glue blocks (M) into position in the upper compartment before sliding-in the partition assembly. Glue all parts in place.

Attach the back (L) to the partitions and bottom with glue and brads. Attaching the back in this fashion will help keep the box and partitions rigid.

Step 12: Dry assemble the base by clamping the base sides (N) to the base top and bottom pieces (S). Slide-in the back (U), then check for squareness and fit. Disassemble and install the Tee-Nuts in the top of the base (**See BOX TO BASE CONNECTION detail**).

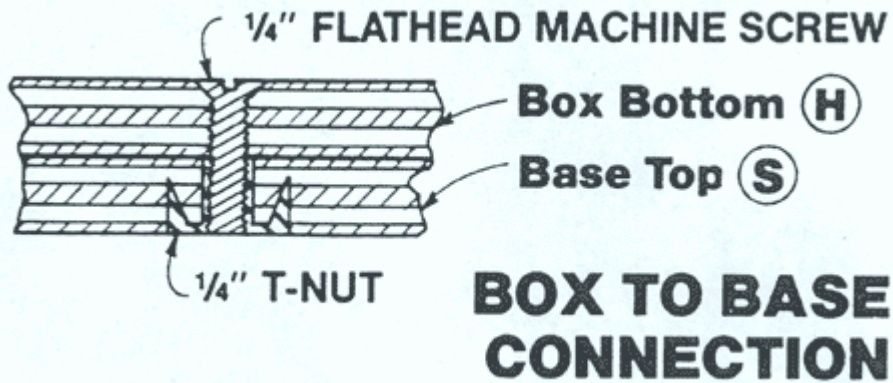

Reassemble with glue and attach the back (U) with glue and brads.

Step 13: Cut the drawer joinery. NOTE: refer to the TYPICAL DRAWER CONSTRUCTION drawing for more detail regarding the cuts made in this step.

Using a table saw blade that makes a 1/8" wide kerf and a tenon cutting attachment, stand each of the (9) drawer fronts (V) on end on your table saw and make a 3/8" deep by 1/8" wide cut, 1/8" in from the back edges at each end. **IMPORTANT:** Be sure to position a piece of scrap stock on the outfeed side of each cut to prevent splintering during the cut.

If you don't have a tenon cutting attachment, you can make this cut by using your table saw's rip fence to control the position of the cut. Again, back-up your drawer fronts with a piece of scrap stock on the outfeed side of each cut to prevent splintering during the cut...and use a feather board to hold your stock firmly against your rip fence while making these cuts.

Re-set your saw's depth-of-cut to 1/8" and cut the 1/8" wide vertical dadoes near the front and back (inside) ends of all (18) drawer sides (W).

Next, use your table saw's rip fence and a stop block to control your cut as you form the 1/8" x 1/8" tongues on each end of the front sides of your drawer fronts (V).

Now, re-set your saw's depth-of-cut to 1/4" and cut the 1/8" wide by 1/4" deep rabbets on the outside of each end of the (9) drawer backs (X).



Re-set your saw's depth-of-cut to 1/8" and cut the 1/8" wide grooves, up 1/8" from the bottoms of all (18) drawer sides (W) and all (9) drawer fronts (V). NOTE: Do NOT cut matching grooves at the bottom of the drawer backs (X).

Change to a dado blade setup and cut the 7/16" wide by 3/16" dados in the (18) drawer sides (W) for the drawer glides (F & R).

Step 14: Dry assemble the drawers upside-down by first clamping the drawer sides (W) to the drawer fronts (V) and backs (X)...while sliding the bottoms (Y) into position from the back. Check for squareness. For final assembly, follow the same steps except use glue in all corner joints (NOT the bottom).

Turn the drawers over. Slide the bottoms into the drawer side grooves from the back. Drive two or three 1" wire brads through the pegboard bottom and into the bottom of the drawer backs. Do not use glue. This will allow the bottoms to move...as well as providing for easy drawer bottom replacement if this should be necessary in the future.

Step 15: Sand the drawers to fit on a stationary belt sander (See Fig. 2), starting with the bottom drawer. Be sure to mark all drawers for location to ensure the best fit...and avoid getting them switched.

Step 16: Belt sand the top of the base and the bottom of the box. Fasten the box to the base with bolts and the Tee-Nut fasteners. Belt sand the top, sides, back and front (with the drawers in place). Be very careful not to sand through the veneer face of the top and the back. Round the edges very slightly -- and very carefully using a sanding block with very fine paper or a radius plane. Remove the drawers, then disassemble the box and base.

Step 17: Cut the lid from the box (See Fig. 3) on your table saw. A hollow-ground planer blade would produce the best results. Set your saw's depth-of-cut at 9/16". At this setting, you will cut through the 1/2" thick lumber, but not through the glue blocks. Finish the job (in the corners) using a hand saw, then smooth all sawn surfaces with a block plane or a sanding block with very fine sandpaper.

Step 18: Drill the 1/4" drawer lock holes in the drawer fronts. The 3/16" diameter rods will slip into these holes, securing the drawers shut. It's vital that all of these holes align perfectly with the holes you drilled earlier in pieces B, E & P in Step 7 above. The best way to do this is to start



with the top drawers and mark the hole locations by shutting the drawer and dropping your 1/4" drill bit down through the hole in the piece above it, marking the holes in the drawer front. Remove the bit and use your drill press (set at a PERFECT 90-degree vertical angle) to drill through the drawer front. Repeat this process for each set of drawers as you move towards the bottom.

Step 19: Mount the hardware. Clamp the top lid to the box and attach the hinges and latches.

Drop the 3/16" steel rods into the locking holes until they bottom out into the shallow holes in the bottom front trim piece (P). Mark them at about 1/2" to 9/16" above the top of the front face (B). Remove the rods and place the marked ends in a metal-jawed vise with the marks flush with the top of the vise jaws. Heat the rod ends with a propane torch to soften them and bend the ends over to a 90-degree angle, forming a short "L" on the end of each rod.

Using a small chisel or rat-tail rasp, cut a 1/4" to 3/8" deep by 1/4" wide notch on the INSIDE (or back side) only of the front face (B). The "L" ends of the rods will slip into these notches when they're dropped into the locking holes -- then the box lid will be shut and locked, holding the locking rods down, locking all drawers shut. It's important that these notches NOT be cut through the front of the front face (B).

Step 20: Final touches. Remove all hardware and finish sand the project inside and out. Apply the finish of your choice and enjoy.



LIST OF MATERIALS

(finished dimensions in inches) (ply = plywood -- hwd = hardwood -- pop = poplar -- peg = pegboard)

Top Box

- A Chest sides(2)(hwd) 1/2 x 12 x 12-1/8
- B Front face (1) (hwd) 1/2 x 4-5/8 x 29-1/4
- C Back face (1) (hwd) 1/2 x 4-1/8 x 29-1/4
- D Partition trim (2) (hwd) 1/4 x 1/2 x 4
- E Front Trim (1) (hwd) 1/2 x 1/2 x 29-1/4
- F Drawer glides (12)(hwd) 11/32 x 3/8 x 11-1/4
- G Compartment bottom (1) (ply) 1/2 x 11-3/8 x 29-1/4
- H Bottom (1) (ply) 1/2 x 11-1/4 x 29-1/4
- J Partitiions (2) (ply) 1/2 x 11-1/2 x 4-1/4
- K Top (1) (ply) 1/4 x 11-1/4 x 29-1/4
- L Back (1) (ply) 1/4 x 8-1/8 x 29-1/4
- M Glue blocks (4) (hwd) 1/2 x 1/2 x 3-7/8

Base

- N Sides(2)(hwd) 1/2 x 12 x 6
- P Front trim (2) (hwd) 1/2 x 1/2 x 29-1/4
- Q Partition trim (1) (hwd) 1/4 x 1/2 x 2
- R Drawer glides (6) (hwd) 11/32 x 3/8 x 11-1/4
- S Top & bottom (2) (ply) 1/2 x 11-1/4 x 29-1/4
- T Partition (1)(ply) 1/2 x 11-1/2 x 2-1/4
- U Back (1) (ply) 1/4 x 6 x 29-1/4

Drawer 1 (make 4)

- V Fronts (4)(hwd) 1/2 x 2 x 11-1/2
- W Sides (8) (pop) 3/8 x 2 x 11-1/2
- X Backs (4) (pop) 3/8 x 1-3/4 x 11
- Y Bottoms (4) (peg) 1/8 x 11x 11-1/4

Drawer 2 (make 1)

- V Fronts (1)(hwd) 1/2 x 4 x 5
- W Sides (2) (pop) 3/8 x 4 x 11-1/2
- X Backs (1) (pop) 3/8 x 3-3/4 x 4-1/2
- Y Bottoms (1) (peg) 1/8 x 4-1/2 x 11-1/4



Drawer 3 (make 2)

- V Fronts (2)(hwd) 1/2 x 2 x 14-1/4
- W Sides (4) (pop) 3/8 x 2 x 11-1/2
- X Backs (2) (pop) 3/8 x 1-3/4 x 13-3/4
- Y Bottoms (2) (peg) 1/8 x 13-3/4 x 11-1/4

Drawer 4 (make 2)

- V Fronts (2)(hwd) 1/2 x 3 x 29
- W Sides (4) (pop) 3/8 x 3 x 11-1/2
- X Backs (2) (pop) 3/8 x 2-3/4 x 28-1/2
- Y Bottoms (2) (peg) 1/8 x 28-1/2 x 11-1/4

HARDWARE

- 1/2" dia. Brass drawer pulls (11)
- Brass corner caps w/ screws (8)
- Brass drawbolt latches w/ screws (2)
- Box lock w/ screws & brass plate
- 14" lengths of brass sash chain w/ roundhead screws (2)
- 1/4" Tee-Nuts (4) 1/4" - 20 by 3/4" long flathead bolts (4)
- Brass hinges w/ screws (1 pair)
- Brass box handles (2 pair)
- 3/16" dia. by 36" long steel rod
- 5/8" wire brads
- 1" wire nails
- #8 x 1-1/4" flathead wood screws

CANDLE SCONCE



Here's an attractive, early American style wall sconce that's universal enough in its design to fit well with practically any home decor. Plus...you can sell them individually, or in pairs to grace both sides of a hall mirror, window, fireplace mantle or wall collage. We made ours from poplar with a walnut stain, but cherry, maple, oak, mahogany or virtually any hardwood will work fine for this project and look great when finished properly.

Begin by making the patterns for both the Back and Chimney Platform from pieces of 1/8" to 1/4" masonite or hardboard.

Cut out the shape for the Back pattern, using your bandsaw, scroll saw or sabre saw and sand the edges smooth with a small diameter drum sander. When making your pattern for the Chimney Platform, be sure to drill a small, 1/32" diameter through-hole at the centerpoint, where the Candle Cup will be mounted.

Trace the Back pattern onto your workpiece, cut out the Back and sand the edges smooth, as you did when making your pattern. If you have a bandsaw or scroll saw, you can pad saw multiple pieces at once (up to the cutting depth limits of your saw) by temporarily attaching them together with double-stick tape, then separating the individual Backs once you've cut them out.



Cut out the 4-1/2" x 5" blanks for the Chimney Platform. Use your Platform pattern to mark the center by inserting a small wire brad through the 1/32" hole and tapping it with a hammer. Using a pencil compass with a soft, #1 or #2 lead, clearly mark the position of the 3/16" deep circular groove that will hold your glass chimney (determine this diameter from the chimney you plan to use). Once you've drawn a dark, easy-to-see circle for your groove location, use a 1/8" diameter drill bit to bore a pilot hole all the way through the Platform stock at the circle centerpoint.

Mount the Chimney Platform blank to your lathe screw center from the back side, so your drawn circle is visible. Using a parting tool, cut a 3/16" deep by 3/16" wide groove in the face of the Chimney Platform. Use some very fine sandpaper to lightly sand off any burrs or rough edges around the groove before removing it from the screw center.

Remove the Platform from the lathe, cut the semi-circular outer shape and sand the edges smooth with your drum sander.

Mount a 2" length of 1-1/2" square stock to your lathe screw center and turn the candle cup.

Shape the edges of the Back and Chimney Platform using a router with a 1/4" rounding-over bit.

Attach the Chimney Platform to the Back with glue and two #10 x 1-1/2" wood screws. Attach the Candle Cup to the Chimney Platform with glue and a #8 x 1-1/4" wood screw. Apply the stain and finish of your choice.

Suggested retail price: \$25 to \$30 each -- \$40 to \$50 a pair

LIST OF MATERIALS

(finished dimensions in inches)

Desk Components	
Back(1)	3/4 x 6 x 30
Chimney platform (1)	3/4 x 4-1/2 x 5
Candle cup (1)	1-1/2 x 1-1/2 x 2
Miscellaneous	
Glass Chimney	
Flathead Wood Screws (1)	#8 x 1-1/4"
Flathead Wood Screws (2)	#10 x 1-1/2"

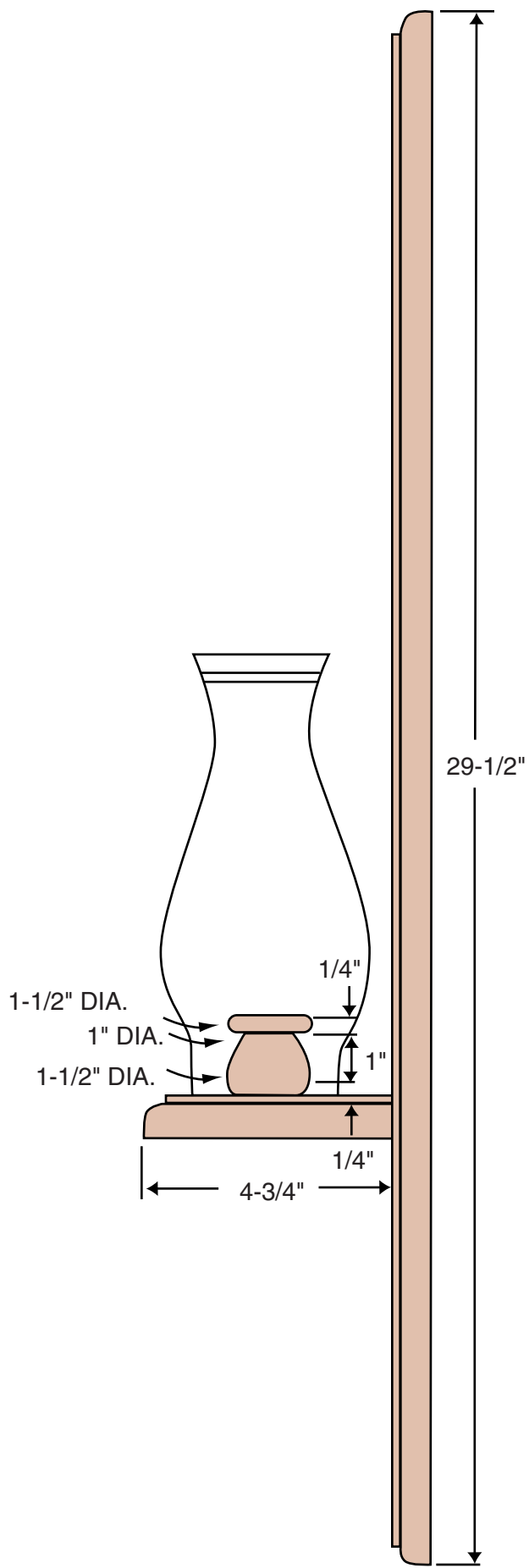

SIDE VIEW

1 GRID SQUARE = 1"

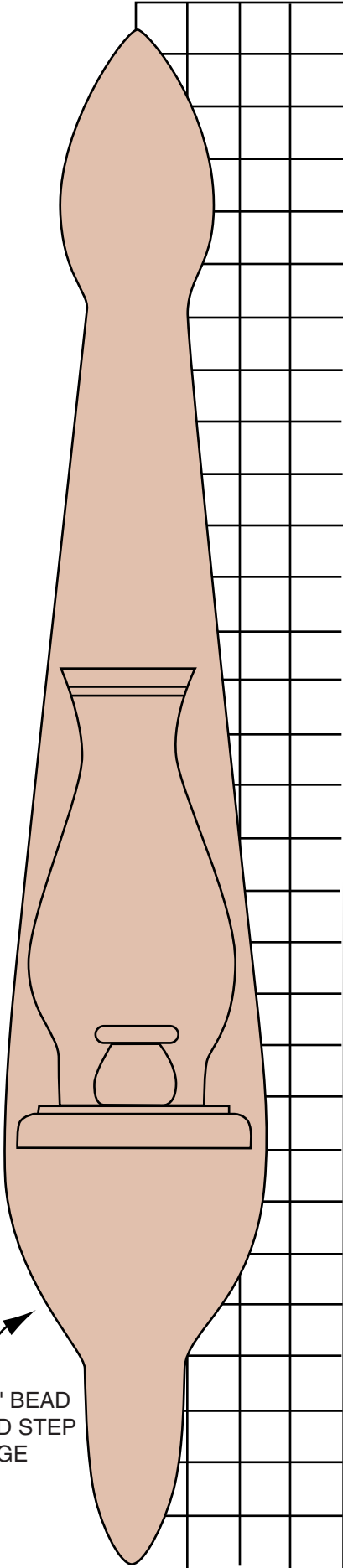

1/4" BEAD
AND STEP
EDGE

FRONT VIEW

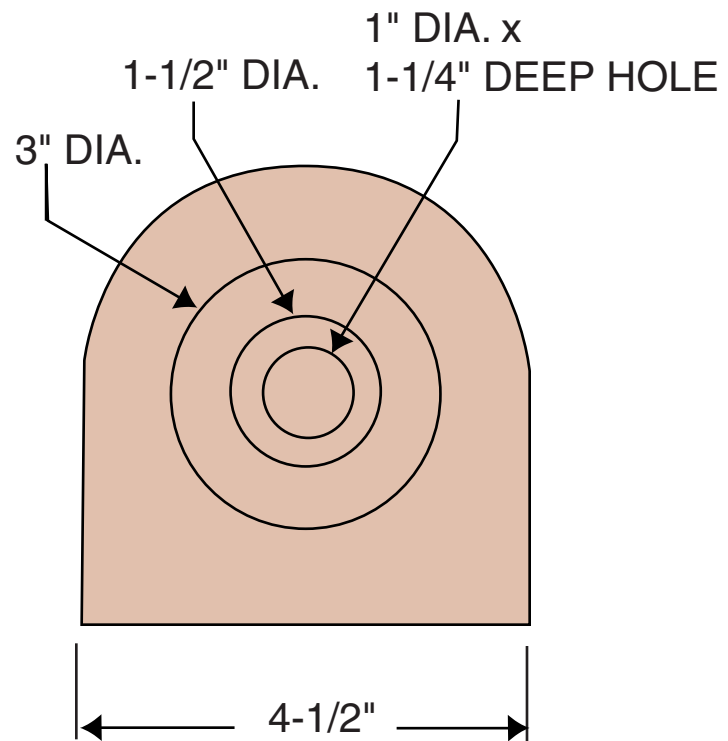

PLATFORM DETAIL

DESKTOP PENCIL HOLDER



Here's an attractive desktop accessory that you can make in no time at all and easily sell for up to \$15. Buyers can use them as intended for a pencil holder...or, with deeper and/or larger diameter holes, even to hold kitchen utensils. In fact, you can increase the overall dimensions of the Holder as you see fit, to serve a variety of purposes by simply using a 1-1/2" or 2" grid when drawing your pattern.

Start by transferring the pattern below to a piece of 1/8" or 1/4" masonite or hardboard. Drill a 1/32" through hole in your pattern at each hole centerpoint.

Glue up a 3" x 5" x 8" block of maple, cherry, oak or any hardwood you choose. If you like, you could even use alternating color hardwoods to create an unusual and attractive effect. Trace your pattern onto the top of your block and use a small wire brad and hammer to mark the hole centerpoints. Set your drill press to run at its slowest speed and bore your holes, using brad point bits and Forstner bits.

IMPORTANT: When using large diameter bits to drill these holes, be sure to retract your bit from the holes frequently to remove shavings and keep from burning your workpiece or bit. Overheating Forstner Bits can cause them to lose the temper in their steel and dull more rapidly.

For Pencil Holders, 3-1/2" deep holes are best. For kitchen utensils, 4-1/2" deep holes provide better support.

Next, cut the outer shape on your bandsaw, then sand all outer edges smooth using a drum sander. Since the project is higher than most drum sanders are long, you'll first have to sand with the top on your sander's table, then flip the project over and sand again with its bottom on your sander's table. As an alternative, you could sand the outer shape over the

drum end of your stationary belt sander. Bevel the top edges using a belt sander or disc sander, apply the stain and cover finish of your choice, glue a piece of felt to the bottom and head for the craft fairs!

Suggested retail price: Up to \$15 for pencil holders...up to \$20 for larger kitchen utensil holders.

Layout

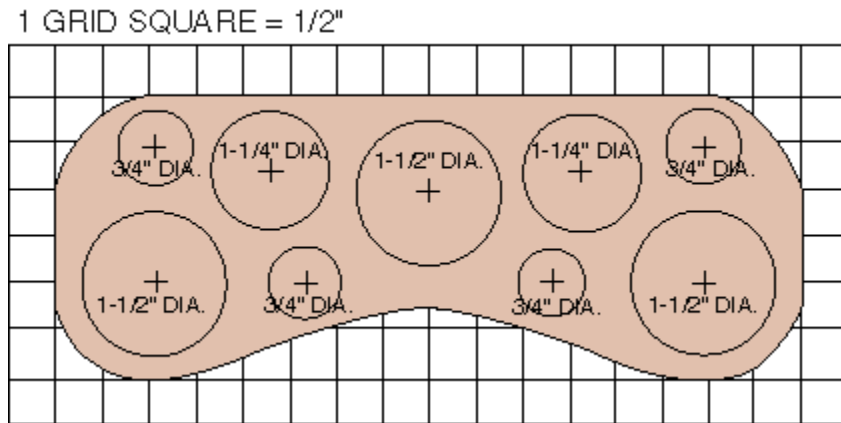

Side View

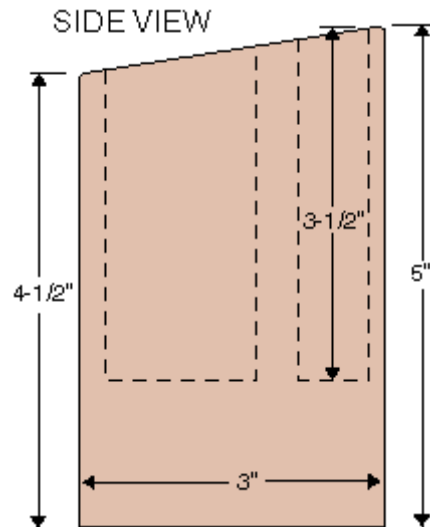

The Garden Bench



This attractive, slat-back Bench makes a perfect back yard spot for whiling away a beautiful Spring or Summer morning

If you've priced sturdy, well-designed outdoor furniture lately, you can probably guess how far ahead you'll be if you can build it yourself! Depending upon the wood used in its construction, a traditional, English-style bench like this one with mortise-and-tenon joinery could easily set you back over a thousand dollars! However, given a couple of weekends, you could craft a beautiful bench like this one at a fraction of that cost -- and enjoy it for years to come.

The bench shown here was made out of teak...an extremely attractive, weather-resistant wood that is probably the most durable of all outdoor woods, but unfortunately, is also very costly. Depending upon where you live, there are many other, less costly alternatives. In the Western United States, you might consider redwood, Western red cedar or white cedar. East of the Mississippi, cypress makes a good choice. And no matter where you live, there's always pressure-treated lumber, oak and similar hardwoods. Another "exotic" that is both attractive and durable is African Bubinga. Retailing for around \$10 a board foot, it has the dark brown appearance of rosewood at a fraction of the cost.

If you choose the most universally available pressure-treated option, it's best to purchase wider, thicker boards than you'll need, then rip, resaw and plane them down to their required dimensions. This way, you'll be eliminating any rough-sawn surfaces and end up with a much nicer looking bench in the end. Also, it's important to be sure all pressure-treated lumber is well dried and that it has been stored indoors, out of the weather. If not, don't buy it! Starting with wet pressure treated lumber can lead to twisting, warping and other problems that could easily ruin your project as it dries out.

Mortise-and-tenon joinery is used extensively in this project and makes for a project that's both attractive and durable. These plans are for a six-foot bench. However, you



could easily make a bench that's longer -- or shorter, and more chair-like, if you prefer. Just remember that if you're planning to make a longer bench, depending upon the wood you use, you may also have to increase the thickness of the seat boards to prevent breakage. This plan is easy to adapt to virtually any length.

Step 1: Cut all of your stock to size, according to the List of Materials...or the adjusted dimensions you prefer.

Step 2: Transfer the pattern for the back legs ([B](#)) to a piece of 4" x 6" stock...and the patterns for the back rail ([F](#)) and arm rests ([E](#)) to 2" x 6" material. Do not cut the contours at this time.

Step 3: Using a square, accurately mark the locations of the mortises and tenons on all parts.

Step 4: Cut all mortises in the front and back legs ([A](#), [B](#)). You can do this by boring a series of 1/2" diameter holes with your drill press, then squaring them up with a beveled-edged chisel. A better alternative is to use a [Hollow Chisel Mortising Attachment](#). This handy accessory will create precision mortises of the desired size in a single action, saving you time and effort. **NOTE:** Due to the length and bulk of the parts for this project, be sure to properly support your stock when cutting your mortises. If you're using a Model 510 MARK V or a unit equipped with the Pro Fence System upgrade, be sure to use your Floating Extension Table, Telescoping Legs and Connector Tubes to provide additional support. If you're using a Model 500 MARK V, a [Roller Support Stand](#) can be most helpful

Step 5: Using a 3/4" wide Dado set-up on your [Table Saw](#), cut the tenons on parts C, D, E, F, G, & J to fit your mortises. Again, due to the length and bulk of the parts for this project, be sure to properly support your stock with Extension Tables or a Roller Support Stand when cutting your tenons.

Step 6: Before removing your Dado Assembly, cut the 3/4" wide x 1/2" deep grooves in the upper and lower Back Rails ([F](#) & [G](#)).

Step 7: Using a Bandsaw, cut out the contours on the upper Back Rail ([F](#)), Legs ([B](#)), Seat Supports ([C](#)), Arm Rests ([E](#)) and Support Brackets ([L](#)). Use your 2-1/4" [Shopsmith Drum Sander Attachment](#) to remove all sawing marks from the edges of parts B, C, E, & F and the [Extra Long Drum Sanding Set](#) to smooth the smaller curves in the Support Brackets ([L](#)).

Step 8: Check the Arm Rests ([E](#)) for fit with the back legs ([B](#)) -- they should fit so they're parallel with the ground when the Bench is fully assembled. Use your Disc Sander to bevel the back ends of the Arm Rests so they fit flush with the sides of the Back Legs



(B). Next, drill the Arm Rests (E) and Back Legs (B) to accept 1/2" diameter x 3" long dowel pins.

Step 9: Assemble the sides one at a time. Be sure to use a weatherproof indoor/outdoor glue such as Franklin TiteBond® II and clamp all parts together firmly and set the glued-up assemblies aside while the glue sets up.

Step 10: Attach the Splats (H) and Splat Spacers (I) to the upper and lower Back Rails (F & G) with glue. It's best to lay the complete assembly flat on the floor or a benchtop while putting it together. Use your glue between the Splats and Spacers sparingly and pull everything together tightly from side-to-side with pipe clamps. Use [Bar Clamps](#) to pull the Upper Back Rail (F) and Lower Back Rail (G) together from top-to-bottom while the glue sets up. **IMPORTANT:** You'll have to move quickly when assembling this portion of the project. Having an assistant to help you is highly recommended.

Step 11: Once the Back Assembly has dried completely, remove the clamps and clean-up any glue squeeze-out before proceeding. Attach the Back Assembly and the Seat Stretcher (J) to the completed Side Assemblies with glue and pipe clamps. Set aside to dry.

Step 12: Use glue and 6d galvanized finish nails to attach the Brackets (L) to Front Legs (A) and Seat Stretcher (J), as shown.

Step 13: Use 8d galvanized finish nails or stainless steel wood screws to attach the Seat Boards (K) to the Seat Supports (C). Cut two 7/16" thick spacers and use them to guarantee even spacing between the Seat Boards during assembly. The front Seat Board will have to be cut to fit between the two Front Legs (A).

Step 14: Reinforce all joinery with two 10d galvanized finish nails per joint.

Step 15: Round off all edges with a rasp or coarse sandpaper, then finish sand the Bench thoroughly to remove all roughness and splinters prior to finishing.

Step 16: Apply the finish of your choice. Remember that although certain outdoor woods (redwood, cedar and pressure treated woods) don't necessarily have to be finished and will "weather" nicely over time, applying a finish will extend the usable life of all outdoor projects. Many such finishes combine attractive stains with a clear over-coat that provides a barrier against ultraviolet rays to ensure that your color remains consistent over long periods. Talk to the technicians at your local paint store or home center for finishing suggestions.

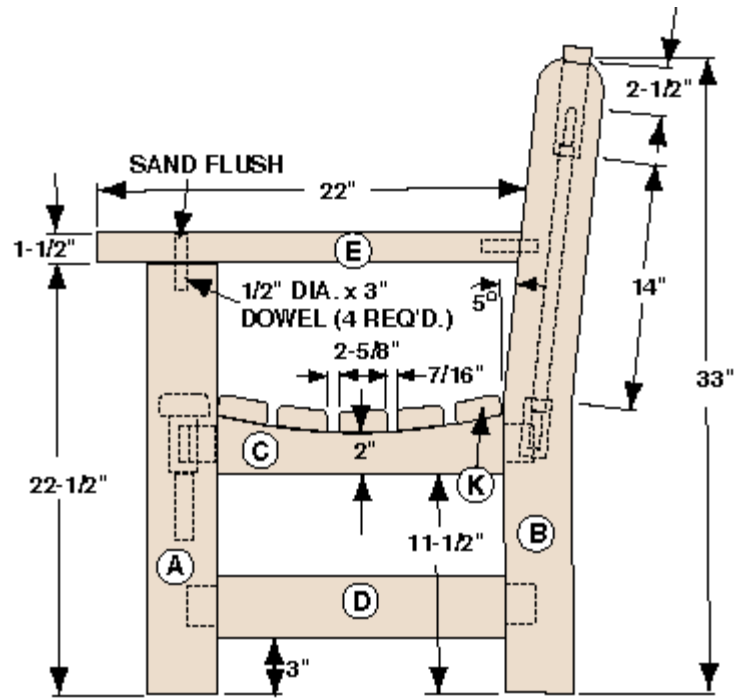

SIDE VIEW

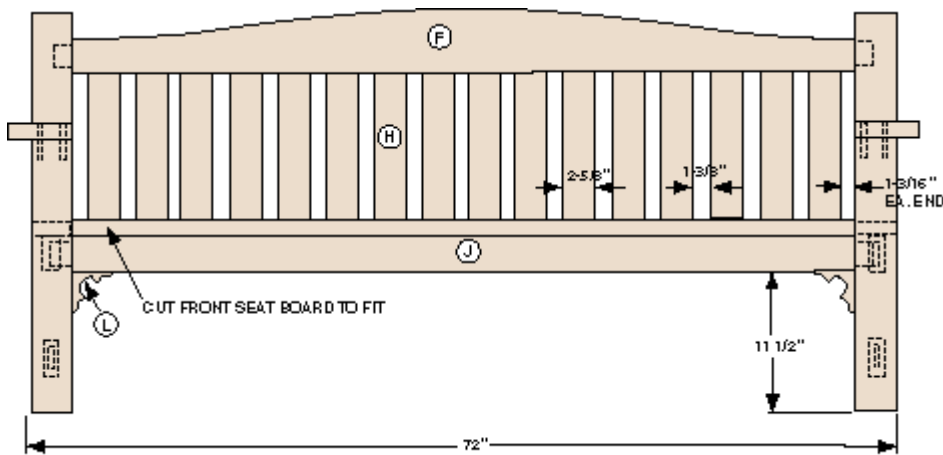

FRONT VIEW

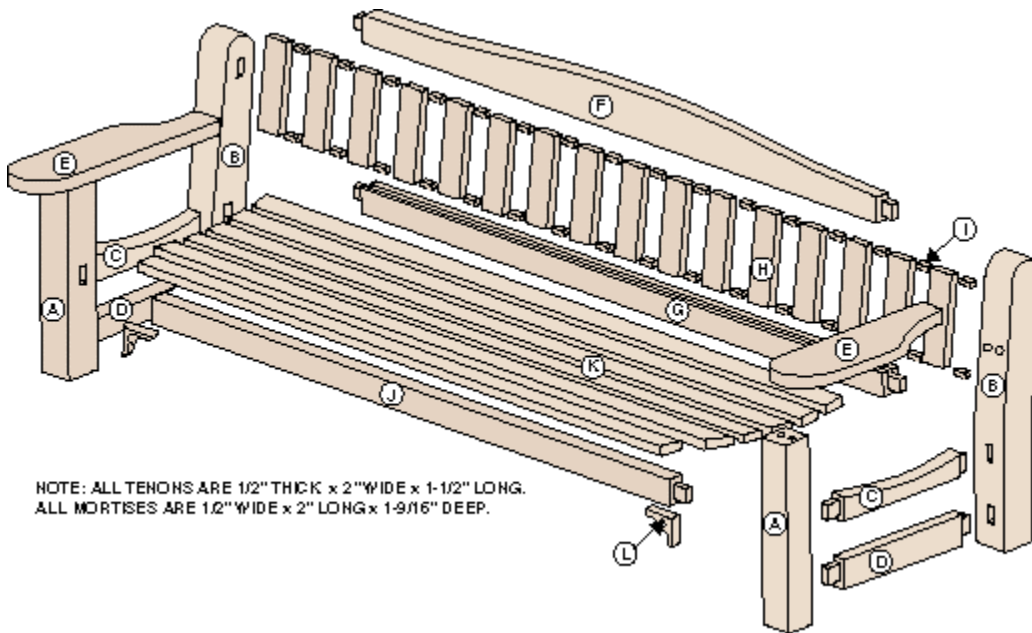

NOTE: ALL TENONS ARE 1/2" THICK x 2" WIDE x 1-1/2" LONG.
ALL MORTISES ARE 1/2" WIDE x 2" LONG x 1-9/16" DEEP.

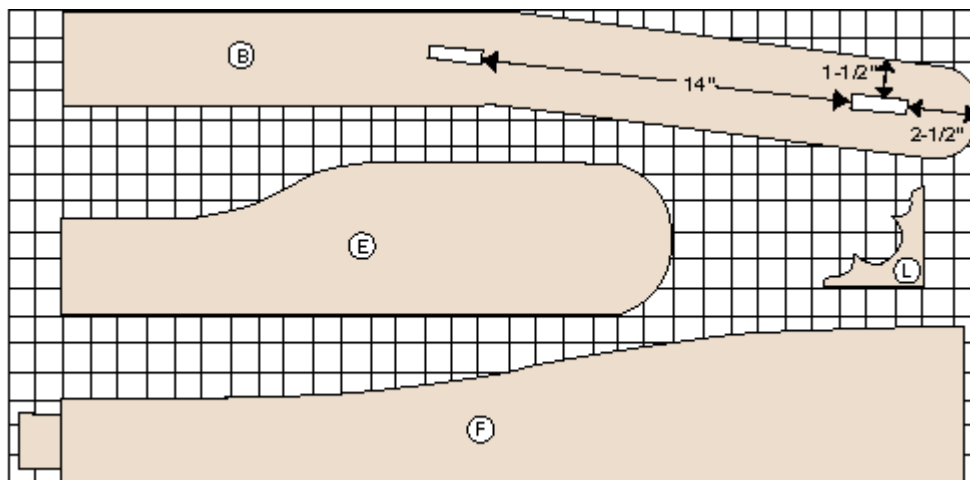

1 SQUARE = 1"



LIST OF MATERIALS
(finished dimensions in inches)

A	Front Legs (2)	3-1/2 x 3-1/2 x 22-1/2
B	Back Legs (2)	3-1/2 x 5-1/2 x 33
C	Seat Supports (2)	1-1/2 x 3 x 18
D	Leg Rails (2)	1-1/2 x 3 x 18
E	Arm Rests (2)	1-1/2 x 5-1/2 x 22
F	Upper Back Rail	1-1/2 x 5-1/2 x 68
G	Lower Back Rail	1-1/2 x 3 x 68
H	Splats (16)	3/4 x 2-5/8 x 14
I	Splats Spacers - center (30)	1/2 x 3/4 x 1-3/8
	Splat Spacers - ends (4)	1/2 x 3/4 x 1-3/16
J	Seat Stretcher	1-1/2 x 3 x 68
K	Seat Boards (6)	1-1/8 x 2-5/8 x 72
L	Brackets (2)	3/4 x 3-1/2 x 3-1/2
	Dowel Pins (8)	1/2 dia. x 3
	Stainless Steel Screws (12) or 8d Galvanized Finish Nails (12)	
	10d Galvanized Finish Nails (28)	
	6d Galvanized Finish Nails (4)	

TALL BOOKCASE



Here's a relatively simple-to-build bookcase that's sure to make an attractive addition to any room in your home. Designed to fill the space from floor-to-ceiling, it offers ten shelves and *cubbyholes* for books, decorator accents and audio/visual components, as you prefer. Our example features a swiveling, slide-out shelf for a compact TV set plus three adjustable shelves and an enclosed cabinet for storing audio/videotapes, compact discs or other items.

A FLEXIBLE DESIGN

The nice thing about this simple design is the fact that it can easily be modified to suit your specific needs. For example, if your room ceiling is lower than 8-feet, make the bookcase shorter. If you need more shelves for audio/visual components, simply add them. If you need a larger space for your television, just eliminate some of the bookshelves, make the cabinet deeper or adjust it accordingly. A few simple adjustments are all that's required to make this attractive bookcase just what you need.

Our example has been constructed in five separate units....the carcass or outer *frame* which is all A/A ("A" grade on both sides), 3/4" red oak veneer plywood; the face frame which is solid 3/4" red oak; the moldings; the cabinet door; and the TV shelf with hardware.

SAFETY NOTE: If you're using a Shopsmith MARK V to build this project, a helper will be handy (and much safer) for cutting the large plywood pieces. If a helper isn't available for one reason or another, we recommend that you



consider adding a Shopsmith Support Table and a Roller Stand or two to help you more safely control the large, cumbersome pieces.

So, let's get started.

1. Cut the plywood to size. Begin by ripping the plywood lengthwise into 16" wide (or your preferred width) strips. Once the pieces are ripped, crosscut them to length as shown in the List of Materials (or to the lengths you prefer, in the case of a modified plan).

2. Cut the dadoes. Mark the positions of all dadoes on the insides of your two outside vertical panels (A & O). Follow the positions shown in the drawing or modify them as you see fit. Remember that (almost) all dadoes will be 3/4" wide and cut to a depth equal one-half the thickness of your plywood (or 3/8").

NOTE: The dadoes on the tops of the two sides (A & O) will form 3/8" x 3/8" rabbets - and the bottom dadoes on both sides of the vertical shelf divider (J) will only be 1/4" deep.

Unplug your MARK V and install your Stack Dado Set or Wobble Dado Blade according to the instructions.

Carefully line-up the marks you made on the edges of your plywood with your Dado Blade. Start by crosscutting your dadoes with one edge flat against your Miter Gauge. A Miter Gauge Extension Face or Cross-Cut Sliding Table and Auxiliary Table will provide additional workpiece support and precision when making these cuts.

This process can be a bit tricky since furniture grade oak plywood has a thin veneer on each outside surface that is highly susceptible to splintering if it's not cut properly. There are two ways to avoid this. One way is to make your dado cuts in two passes....the first just a little over 1/32" deep to "score" the veneered surface before cutting your dado to its final depth. The second way is to cover the entire length of your dado cut with a piece of masking tape before making your cut (be sure to set your blade cut depth just a "shade" deeper to compensate for the thickness of the tape). If you're using this second procedure, once your cut's been made, *slowly and carefully* remove the tape.

Set your MARK V's Speed Dial to "R" and make your cuts, pushing your workpieces slowly over the dado blade, almost at a snail's pace, giving the blade ample time to make the cuts.



Once you've cut the dados on the sides (A & O), go ahead and cut the remaining dados on the shelf divider (K) and fixed shelves G & N). Next, mark the dados on the vertical shelf divider (J). **NOTE:** Since the bottom dados on this piece will be adjacent to each other, adjust your depth-of-cut to make them just 1/4" deep. Mark and cut the single dado in the center of the top (B)...but NOT the ones on the ends.

3. Cut the other dados and rabbets. Once you've cut all of the 3/4" wide dados, re-set the width of your dado cut to 3/8". As you can see from the illustration of the top corner dado-rabbet joint, the dados on the ends of the top (B) are just 3/8" wide by 3/8" deep and 3/8" in from the ends of the top. They are designed to accept the 3/8" by 3/8" rabbets formed on the top ends of the sides (A & O). Mark and cut these dados. Next, make the L-shaped rabbet cuts on the tops of the sides (A & O), as shown in the Drawing. Use the same 3/8" wide adjustment on your dado blade to cut them to a depth of 3/8", forming the rabbets. **NOTE:** Notice that these cuts are on the opposite sides of the side pieces (A & O), from the dados you cut previously.

4. Finishing. We recommend that you finish all plywood boards at this time so you can work with them while they lie flat to avoid runs. Here's another tip: Put masking tape on all board ends and on the bottoms of all dados where the joints come together. This will give all your glue joints a better bond.

5. Drill shelf bracket holes. We used brown, plastic shelf brackets to support our adjustable shelves. They're readily available at your local hardware stores or home centers like Lowe's. Choose the ones made to fit into 1/4" holes. Mark and drill 1/4" holes, set 2" in from the fronts and backs of the right side (O) and vertical shelf dividers (J & K). Space them at 2" vertical intervals.

6. Glue up the carcass.



For this, you'll definitely need the help of an assistant to provide an extra pair of hands while you glue-up all the awkward carcass pieces with yellow woodworker's glue. Before you get started, dry assemble all of the pieces to be certain everything fits together properly. If not, make any necessary adjustments before applying glue to any components. Get all the clamps



you'll be needing for the job and go to work. Leave out the adjustable shelves (F, H, M) and the TV shelf (P) during the glue-up. Don't glue on the top (B), yet. Just set it into position on top without any glue for now.

7. Cut the pieces for the face frame.

Start by cutting the left side (Q), right side (R), top (S) and bottom (T). Do not cut the narrower, 3/4" molding strips at this time. If possible, use a helper or roller support stand to support the long, 96" pieces as you cut them.

8. Joint the edges. Run the edges of your face frame pieces over the jointer to square them up and smooth them out. This gives a much smoother edge than you can achieve with a table saw alone.

9. Drill the dowel holes.

Set up your MARK V for the horizontal boring mode. Drill 3/8" holes in the top and bottom edges of the long, 96" side pieces (Q & R). Each joint will have two dowels. Measure the spacing of these holes carefully so they will fit into the ends of the 3" wide bottom piece (T) and the 4" wide top piece (S). Make your holes slightly deeper than one-half the length of your 3/8" dowels to allow for glue escapement.



10. Match the dowel positions. Place two 3/8" dowel centers into the holes at the bottom edge of the left side piece (Q). Use a try square or combination square to line up the bottom piece (T) with the left side piece, then push the bottom piece (T) against the side piece (Q) and tap with a mallet to transfer the hole locations to the bottom piece (T). Repeat this process for the right side piece (R). Follow the same procedure for the top piece (S).

11. Glue up the outer frame. Glue the 3/8" dowels and edges of the outer frame pieces where they will join. Clamp them together and allow the glue to dry.

12. Finish the frame. Follow the same procedures you followed earlier. Finish all additional pieces similarly, just prior to assembling them.



13. Attach the face frame. Use small finishing nails (two inches long - 6 penny) to attach the outer face frame to the carcass. To avoid splitting the oak, it's a good idea to drill small pilot holes into the frame first.

14. Cut the shelf and divider edge moldings. Working with one of your 48" x 10" x 3/4" pieces of red oak, rip a sufficient quantity of 3/4" wide strips (off the full 48" length of your oak) to create solid wood edge moldings for the fronts of all shelves and vertical dividers, as well as the front and sides of the TV shelf.

15. Crosscut the edging to their appropriate lengths. Measure the lengths of these moldings after the outer frame has been attached to the carcass. Begin with the two full-width horizontal shelves (G & N). Next, cut the moldings for the vertical dividers (L, K & J) to fit between these shelves. Finally, cut the edge molding on the remaining shelves (C, D, E, F, H, I & M), keeping in mind that they will be attached using common butt joints as shown in the "Face Frame & Molding" illustration.

16. Attach the edge moldings. After finishing the moldings (except for their back or glued edges), attach them to all edges using glue and 2" finishing nails. **NOTE:** Don't forget to pre-drill nail pilot holes in your oak strips to prevent splitting. Use a nail set to recess the heads of all nails, then cover the holes with wood patch that's been mixed with matching stain.

17. TV shelf hardware. A combination shelf slide and lazy susan commonly referred to as a "TV Extension Slide" will be used to hold your TV shelf (P) and eventually your TV set. Attach the slide to the TV shelf (P) and fixed shelf (N) with #8 x 3/4" wood screws.

18. Make the top crown moldings. Use your Shopsmith Shaping Package with a Bead & Cove Cutter to create the crown molding for the top of the bookcase. Start by shaping one edge of a wide piece of your oak...then flipping your piece over and shaping the opposite edge. Once both edges are shaped, rip one side down to 3" wide, and the opposite side down to 1" wide. Repeat this process so you'll have two 3" wide and two 1" wide molding strips that are 48" long, each with one bead & cove edge.

All of the molding pieces must be measured precisely and cut with 45-degree bevels on the front corners, where they meet the mating moldings on each side. To avoid mistakes, we suggest clamping each 3" piece in place at the top of your bookcase and checking precisely where the bevel cuts should go. A Shopsmith Miter-Pro, used with your MARK V Miter Gauge will help ensure the accuracy of these 45-degree cuts.



Once you've cut the 3" wide pieces, lay your 1" wide pieces on top of the 3" pieces and mark them so they will continue your 45-degree angles. Note that the 1" pieces must eventually be longer than the 3" pieces for the corners to meet properly when the moldings are assembled to the bookcase carcass.

After cutting the bevels, glue-up the 3" and 1" moldings together as shown in the "Crown Molding" illustration. Line up the beveled edges and clamp them together while the glue dries.



Finally, clamp each of the three pieces of assembled crown molding into position on the top of your bookcase. Line up the two front corners carefully and clamp them into position while you drill pilot holes from the inside of the bookcase - through the top face frame (S) and sides (A & O) and into the back sides of the moldings. **NOTE:** When assembled, the molding should protrude 3/8" above the top surface of the cabinet top (B), making an overall bookcase height of 96". Assemble the moldings to the bookcase using glue and #8 x 1-1/4" wood screws. Once the moldings are assembled to the carcass, glue the top (B) into place.

19. Make the door. This door is optional and hides the audio/video tape and compact disc storage shelves. The vertical door stiles and horizontal rails can be made on the shaper using the Complete Cabinet Set cutters. Or, if you prefer, you could use the Shopsmith Router Package , Routing Table Kit or Pro Fence System Router Table with the Reversible Stile & Rail Router Bit Set.

It's important to note that using these cutters properly requires some practice and, depending on whether you use the shaper cutter set or router bit set, the overall profiles they produce may be somewhat different than the photo shown immediately below. Therefore, it's recommended that you practice making these cuts on some scrap wood (of the exact same thickness) prior to cutting the profiles in your oak pieces. It may be a challenge for you to achieve a perfect fit, but the finished appearance of your door will make all the effort worthwhile.

Once your rails and stiles have been cut and their edges created, slide a piece of 1/4" thick oak veneered plywood into the groove on the inside edges of your door frame pieces before gluing the stiles and rails together. **Do not glue the plywood panel to the rails & stiles.** No dowels will be necessary



for assembly, since the cutters you use will create the proper corner joints for you.



Apply the appropriate finish to your assembled doors, add hinges and attach the doors to your bookcase.

Top corners: Dado-Rabbet Joint

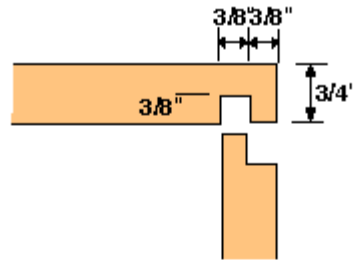

Fixed shelves: Dado Joint

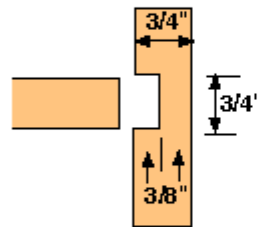

Face frame: Dowels

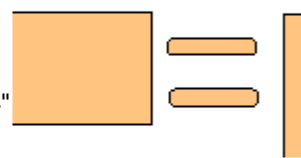

Crown Molding

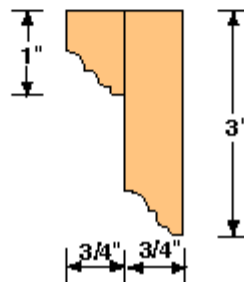

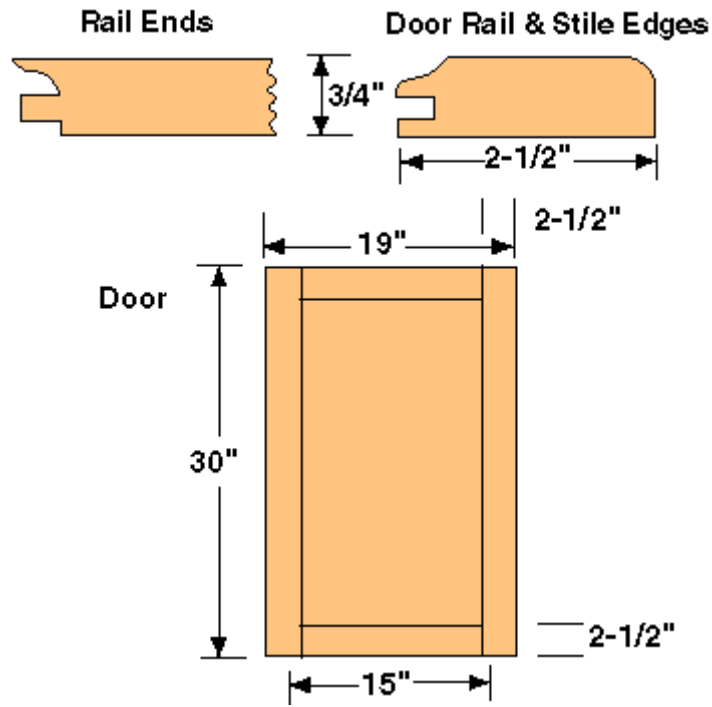

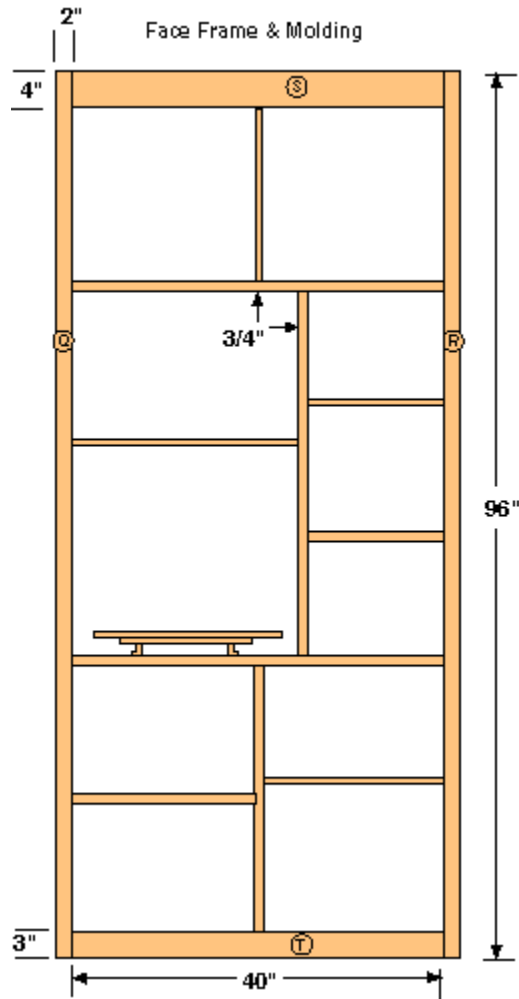

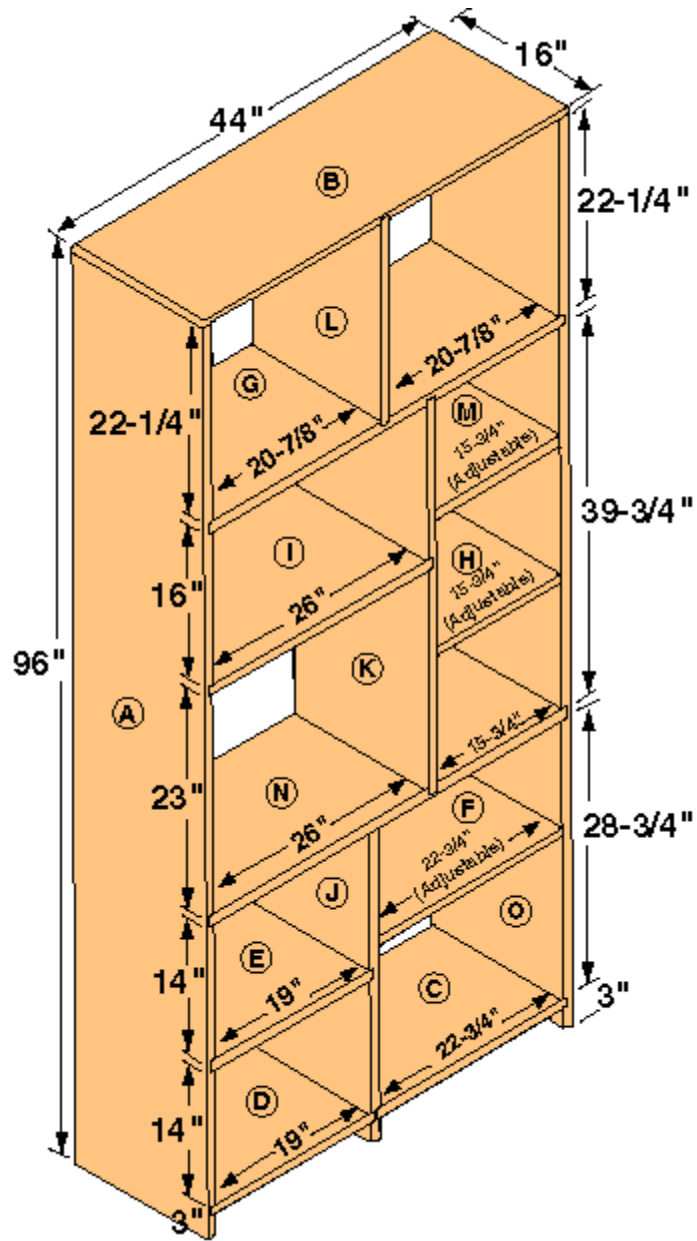



LIST OF MATERIALS

(finished dimensions in inches)

A	Left Side	95-5/8 x 16
B	Top	44 x 16
C	Fixed Shelf	23-1/2 x 16
D	Fixed Shelf	19-3/4 x 16
E	Fixed Shelf	19-3/4 x 16
F	Adjustable shelf	22-3/4 x 16
G	Fixed Shelf	43-1/4 x 16
H	Adjustable Shelf	15-3/4 x 16
I	Fixed Shelf	26-3/4 x 16
J	Shelf Divider	32-1/8 x 16
K	Shelf Divider	40-1/2 x 16
L	Shelf Divider	23 x 16
M	Shelf Divider	15-3/4 x 16
N	Shelf Divider	43-1/4 x 16
O	Shelf Divider	95-5/8 x 16
P	Shelf Divider	21-1/2 x 15
FACE FRAME - 96" x 12" x 3/4" red oak		
Q	Left Side	96 x 2
R	Right Side	96 x 2
S	Top	40 x 4
T	Bottom	40 x 3
CROWN MOLDING - 48" x 10" x 3/4" red oak		
SHELF MOLDING - 48" x 10" x 3/4" red oak		
DOOR FRAME - (optional) - 48" x 6" x 3/4" red oak		
DOOR PANEL - (optional) - 26" x 15" x 1/4" red oak veneer plywood		



HARDWARE

Quantity	Description
8	3/8" dowels
4 dozen	2" finishing nails (6-penny)
1 dozen	#8 x 1-1/4" wood screws
2 dozen	#8 x 3/4" wood screws
1 dozen	Plastic shelf pin/brackets
2	Cabinet door hinges with screws (optional)
1	TV extension slide (optional)

Special Cutting Instructions: Rip both sheets of plywood into 16" strips, 96" long. On the first 96" length, cut pieces B, F and I. On the second length, cut pieces E, J and K. On the third length, cut pieces C, G and L. On the fourth length, cut pieces D, H, M and N. The two remaining 96" lengths will be used for the sides, A & O.

FOLDING PARTY TRAY



You've planned a cookout and your guests are scheduled to arrive in 15 minutes. You've already dragged that wobbly old card table out *just one more time* and set it up beside your picnic table on the patio or deck. But you still don't have enough space for all your guests. So, you're back in the house, scrounging around for more tables when the doorbell rings. You open the door and there they stand...as if they all arrived in a single bus. A quick count and your worst nightmare becomes reality...you have four more guests than places to seat them. Your four closest friends end up in folding chairs with paper plates full of food balanced precariously on their knees and barbecue sauce dribbling down their pant legs. GREAT!

Next time, get those plates off their laps and give them a place to ENJOY their meals with these handy, fold-away party trays. Made of redwood (or any wood of your choice), they're not only utilitarian, but beautifully designed and easy to build, too.

Getting Started

To build the project, you'll need your MARK V (or a table saw) and jointer for making your sizing cuts (the jointer is optional)...a drill press (or your MARK V) for boring the bolt and screw holes...a band saw or scroll saw and a disc sander to round and smooth your parts.

Component Construction

Before you get started, keep in mind that since all the tool set-ups for this project are so simple, it's almost as quick and easy to go ahead and make six or so of these trays, while you're at it. Making more is a simple matter of running additional lumber through your machinery. Of course, you'll need a little extra assembly time too, but you'll quickly discover that it's a lot easier to make more trays now than to go back and re-do all your set-ups for



another "run" at a later date. So, think about how many you might need and "do it now". You'll be glad you did.

Since our plan calls for outdoor use, we used redwood for our trays. It's attractive, light in weight and resistant to decay. However, you could just as easily make these trays out of virtually any clear, attractive lumber. The choice is yours.

Start by using your table saw to cut all of your pieces (A,B,D,F,G,H) to size, as shown in the Bill of Materials. Rip everything to width first, making all your pieces just a "hair" oversized so you can run them over the jointer to smooth the edges prior to assembly...then crosscut them to length. Cut out an extra piece, from which you will cut however many small, round spacers (C) you may need for the number of trays you plan to build. Use a pencil compass to draw a sufficient quantity (two per tray) of 1" diameter spacers on this piece of stock.

Next, lay out the holes for the carriage bolts and dowel braces (E) in the four legs. Using a 3/4" Brad Point Drill Bit, bore the through-holes for the dowel brace (E) and the 1/4" deep counter bore holes (for the carriage bolts). Note that for each tray, two of the legs have a through hole at the top end...the other two legs have a counter bore at the top end...and all four legs have a counter bore near their centers.

A DRILLING TIP: If you're using the MARK V drill press setup, set your rip fence to establish the hole centerline on your leg boards. Using the same 3/4" bit, drill the through holes in the brace locks (F) that will form the back sides of the notches that will accept the dowel brace (E) when the trays are opened...and the 3/4" internal radius at the left end of each Skirt (G) to accept the dowel brace when the trays are closed.

Change to a 1/4" diameter brad point bit and drill the carriage bolt holes in all the legs. Use the recesses that were created by the tip of your 3/4" brad point bit when you drilled your counter bores (or leave your rip fence at the same setup) to guide the positioning of these holes. Drill the center holes in the spacers (C) that you drew on your stock with a compass.

Bore the 3/16" diameter (through) body holes and 3/8" diameter (3/4" deep) counter bores up through the bottoms of the skirts (G) and all the way through the un-notched ends of the brace locks (F) for your attachment screws.

Bore the 3/16" diameter through holes in the ends of the upper and lower braces (B & D) -- and the (1/2" thick) top sides of the notched ends of the



brace locks (F). Form shallow countersinks in these holes for the heads of your flathead attachment screws.

Use your band saw or scroll saw to cut out the round spacers; round the ends of the legs (A) and outside radius of the brace locks (F); create the notched and radiused skirt (G) ends; and form the 3/4" wide notches in the brace locks (F).

Use your disc sander to smooth all outside radiuses...and a small drum sander to smooth your inside radiuses and brace lock (F) notches.

Assembly

Assemble each party tray using the hardware listed in the Bill of Materials. Use glue or not, as you see fit. If you do chose to use glue to reinforce the trays - and you're planning to use the trays in an outdoor environment -- be sure to use a weatherproof glue such as TiteBond II.

Begin by assembling the two leg sets with 2-1/4" carriage bolts, locking cap nuts, washers and spacers. Tap the bolt heads gently into the counter bore to seat the square shanks and prevent bolt rotation during tightening. Be sure to leave enough "play" for the leg sets to pivot smoothly without wobbling when tightening. Connect the two leg sets together by attaching the upper (D) and lower (B) braces to the legs with #8 x 1-1/2" flathead wood screws, as shown. Insert and glue the dowel brace (E), as shown.
NOTE: Take care to be sure the leg sets are "square" when assembled.

Attach the assembled leg sets to the skirts using two 1-1/2" carriage bolts, flat washers and cap nuts...again, being careful to leave enough "play" for smooth operation without wobbling. Slide the bolts through from the inside of the skirts out and tap the bolt heads gently into the counter bore to seat the square shanks and prevent bolt rotation during tightening.

Assemble the top by laying the boards (H) on a flat surface and spacing them 1/8" apart with scraps of 1/8" masonite or corrugated cardboard. Use your assembled leg set to carefully position the skirts (G) and brace locks (F). Drop your #8 x 2" roundhead wood screws into the pre-drilled holes in your skirts and tap their heads gently by using a nail set or pin punch to mark the locations for screw pilot holes in the undersides of your top boards (H). Use your drill press and a 3/32" twist drill to bore 1/2" deep pilot holes at all marked positions.

TIP: To be sure everything fits together properly, remove one top board at a time to drill these holes, then return it to your assembly area before drilling another top board. After drilling all of your pilot holes, return the skirts (G) to



their appropriate positions and screw them to the top boards (H) from the underside using #8 x 2" roundhead wood screws and flat washers (use glue or not, it's your choice).

Screw the brace locks (F) into position inside the (inside) legs at the edge of the top opposite the side where the top leg pivot bolts attach through the skirts (G). See the photo of the woman holding the folded tray for reference. Use #8 x 2" roundhead screws with washers for the radiused ends of the brace locks (F), and #8 x 1" flathead wood screws for the notched ends.

Sand and finish each tray as you see fit. Happy partying !

LIST OF MATERIALS

(finished dimensions in inches - all made from 1/2" plywood)

A	Legs (4)	3/4 x 2-1/8 x 28
B	Lower Brace (1)	3/4 x 2-1/8 x 22-1/2
C	Spacer (2)	3/4 x 1" outside diameter
D	Upper Brace (1)	3/4 x 2-1/8 x 19-1/2
E	Dowel Brace (1)	3/4 dowel - 19-1/2 long
F	Brace Lock (2)	3/4 x 2-1/8 x 3-13/16
G	Skirt (2)	3/4 x 2-1/8 x 15-5/8
H	Top (4)	3/4 x 3-13/16 x 24

HARDWARE

(2)	1/4 "-20 x 1-1/2" carriage bolts
(2)	1/4 "-20 x 2-1/4" carriage bolts
(4)	1/4 "I.D. flat washers
(4)	1/4 "-20 locking cap nuts
(26)	#8 x 2" roundhead wood screws
(28)	#8 I.D. flat washers
(2)	#8 x 1" flathead wood screws
(8)	#8 x 1-1/2" flathead wood screws

Side View

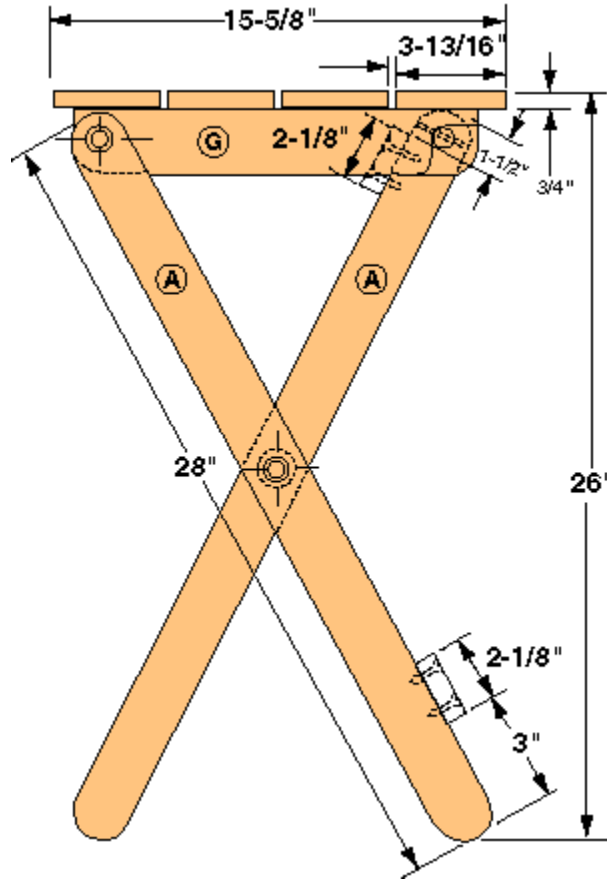

Leg and Space Layout

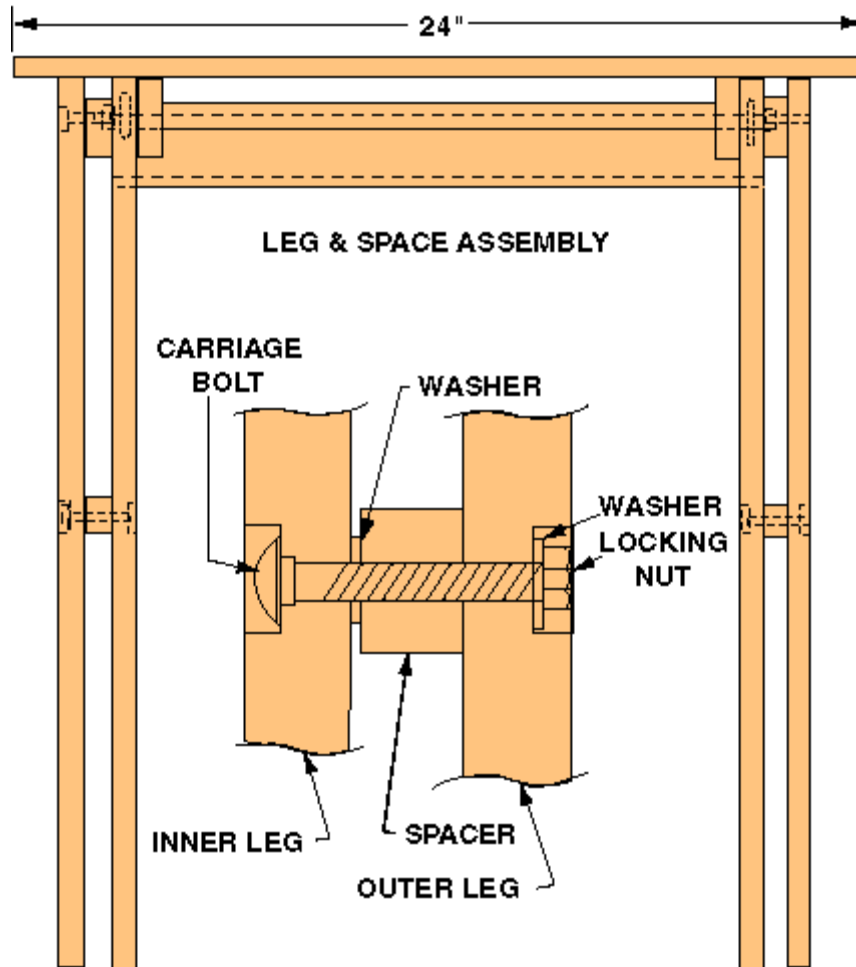

Brace End Layout

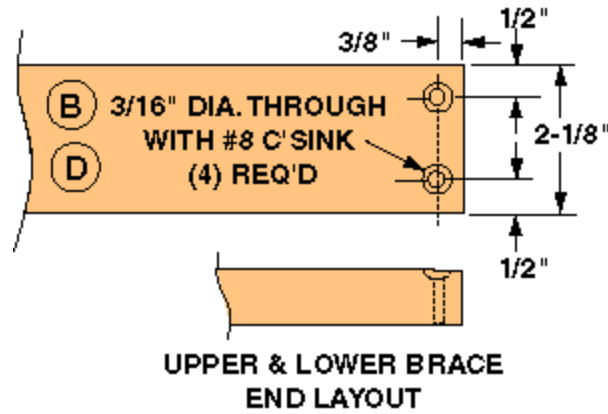

Brace Lock and Spacer

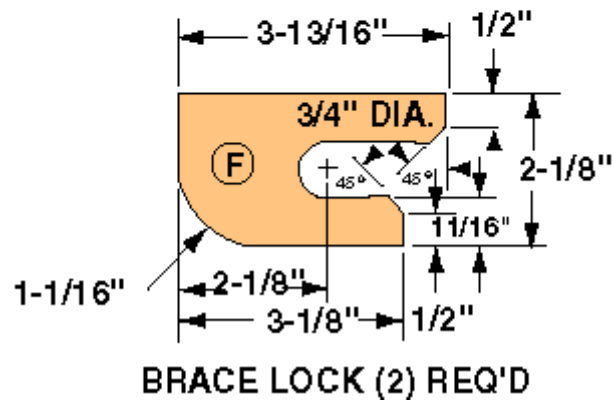
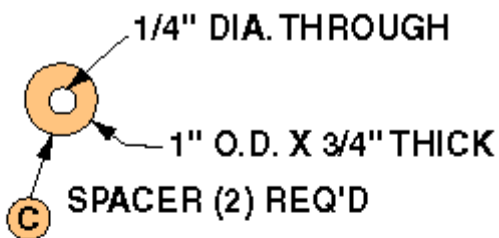

Skirt Layout

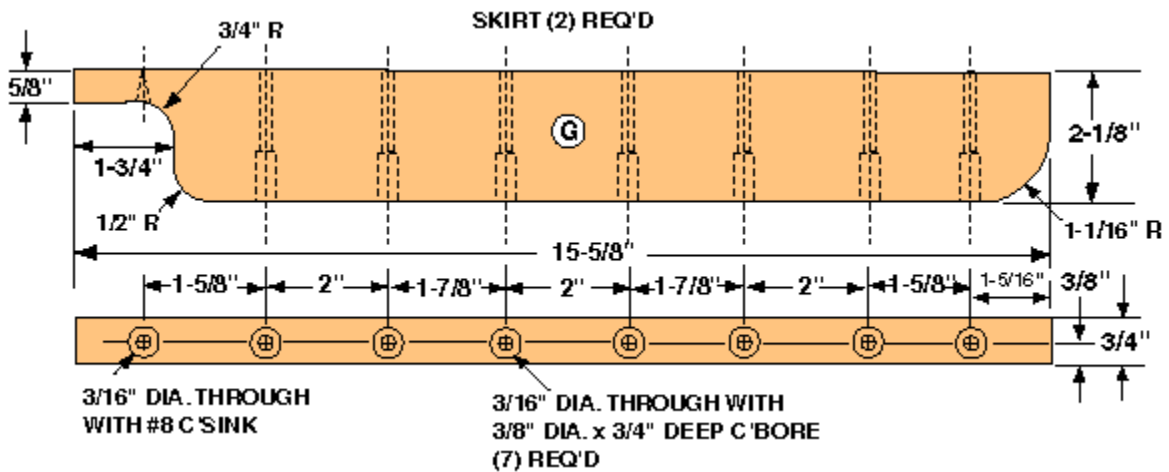

Inner Leg Layout

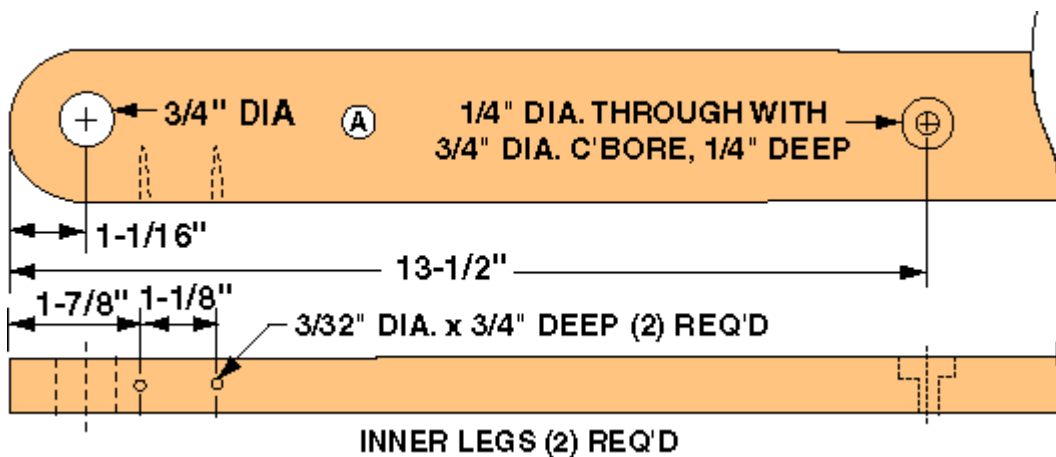

Outer Leg Layout

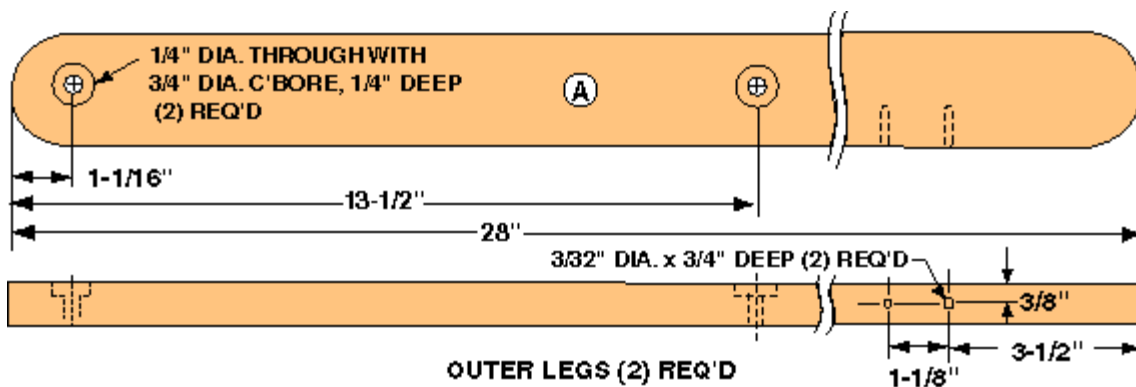

Assembly

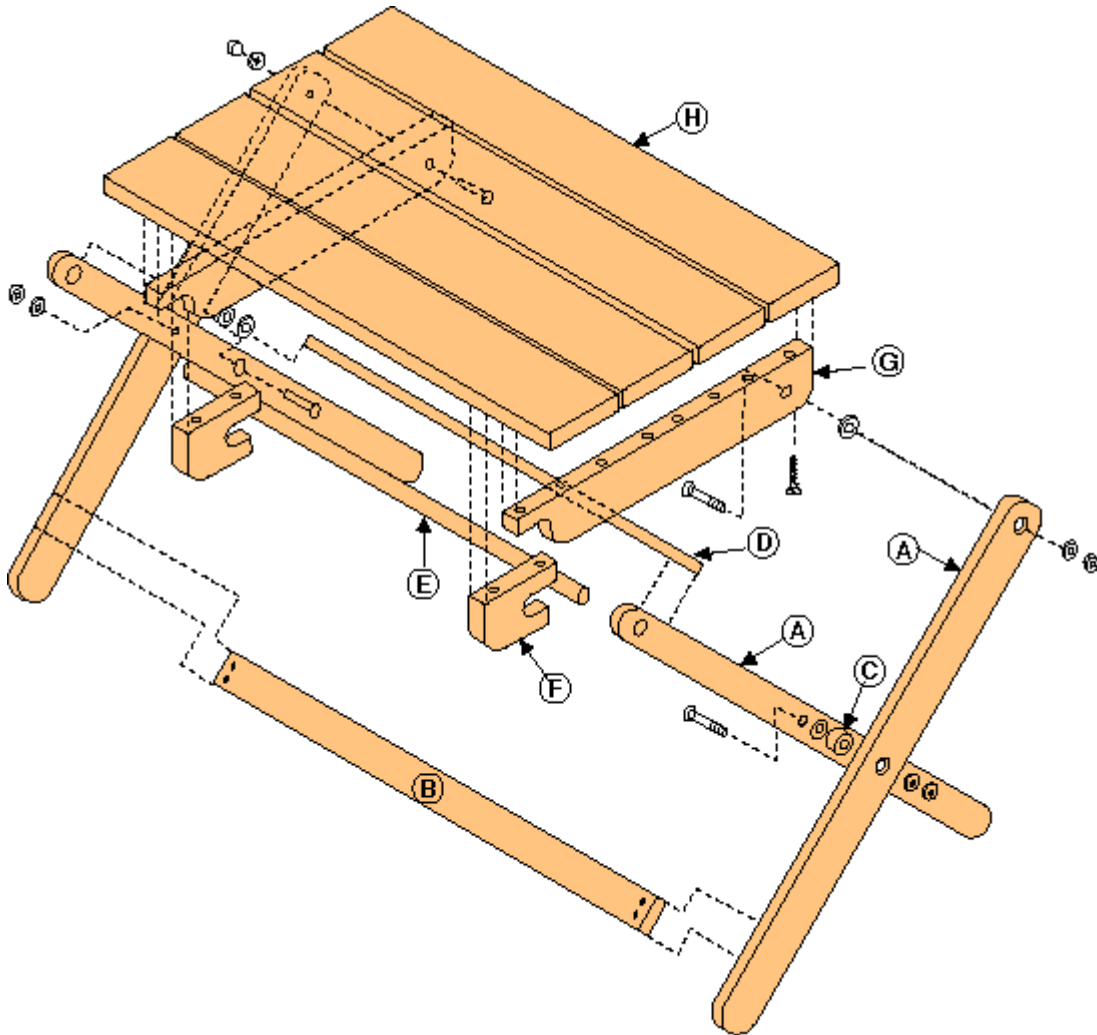

MUG HOLDER SHELF

Here's an easy-to-make working crane that's destined to get plenty of hours of play time

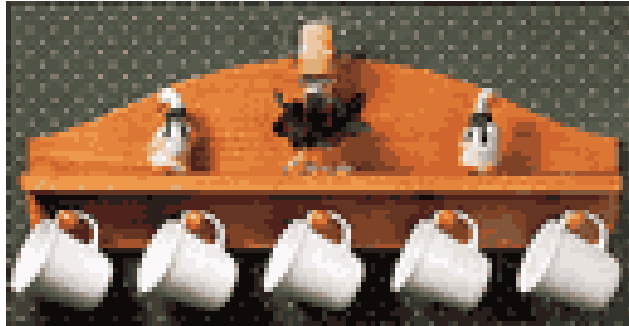

Looking for a fast-selling item that's quick and easy to make? You just found it ! Here's an elegant and practical item that looks great in any kitchen, whether its décor is Early American or more traditional. For a more contemporary look, replace the arched top with a straight one and the shaker style pegs with straight, 1/2" diameter dowel rods glued into position at a slight angle.

For our example, we used red oak with oak shaker pegs...but you could just as easily make the Holder from a light-colored wood such as maple, birch or pine with birch shaker pegs...or, for a higher priced model, choose cherry or walnut with matching pegs you turn yourself on a lathe.

To build the project, you'll need a table saw with dado attachment, a disc sander and a drill press. As an option, a shaper or router set-up could be used to shape the edges of the project for added value.

If you're making our arch-topped model shown here, you'll also need a bandsaw or scroll saw. To save time when cutting the tops on the curved versions, you can stack four or five blanks together with double-sided tape and "pad saw" them all at once using your bandsaw.

1. Cut the backs (A) and shelves (B) to length using the table saw.
2. Change to a dado set-up and cut the 3/4" wide by 3/8" deep groove that holds the shelf. (**NOTE:** The width of this groove could change slightly, depending on the actual thickness of your wood)
3. Make a template for the back profile by transferring the (1" grid) pattern shown below to a piece of cardboard or hardboard (Masonite)...then flipping the pattern over to form the other half. Use this template to trace the profile onto your backs (A). Use a shop-made 2" radius circle template or compass



to mark the lower corners of the back, and a similar 1/2" template for the front corners of the shelf (B). Cut out the back profile using your bandsaw or scroll saw. Be sure to feed your stock slowly through the cut to maintain accuracy.

4. Use a drum sander to smooth the curved top of the back...and a disc sander to smooth the two bottom radii and the two front corners of the shelf (B).

5. OPTIONAL: To increase the value of these shelves, you might consider shaping the edges of the back and shelf, using the Shopsmith Shaping Package or Pro Fence System Router Table. We suggest that you use a 3/16" cove and bead cutter with the Shaping Package or a 5/32" Roman Ogee bit if you're using the Router Table.

6. Lay out and use your drill press to bore the 1/2" dia. holes in the back for the pegs. Test fit one of the pegs to check for the proper hole depth.

7. Finish sand the shelf and back with 100-grit sandpaper.

8. Glue and clamp the shelf to the back. Glue the pegs into their holes.

9. For wall mounting, attach screw eyes and a picture hanging wire...sawtooth hangers or picture hanging tabs to the back. As an option, you could use a router with a T-Slot Bit to create hanging slots in the back side.

10. Apply the stain and cover coat of your choice. Suggested retail price: \$25 to \$30

LIST OF MATERIALS

(finished dimensions in inches)

A	Back (1)	3/4 x 8-1/2 x 26
B	Shelf (1)	3/4 x 3-1/2 x 26
C	Shaker pegs or 1/2" dowels (5)	

Plans

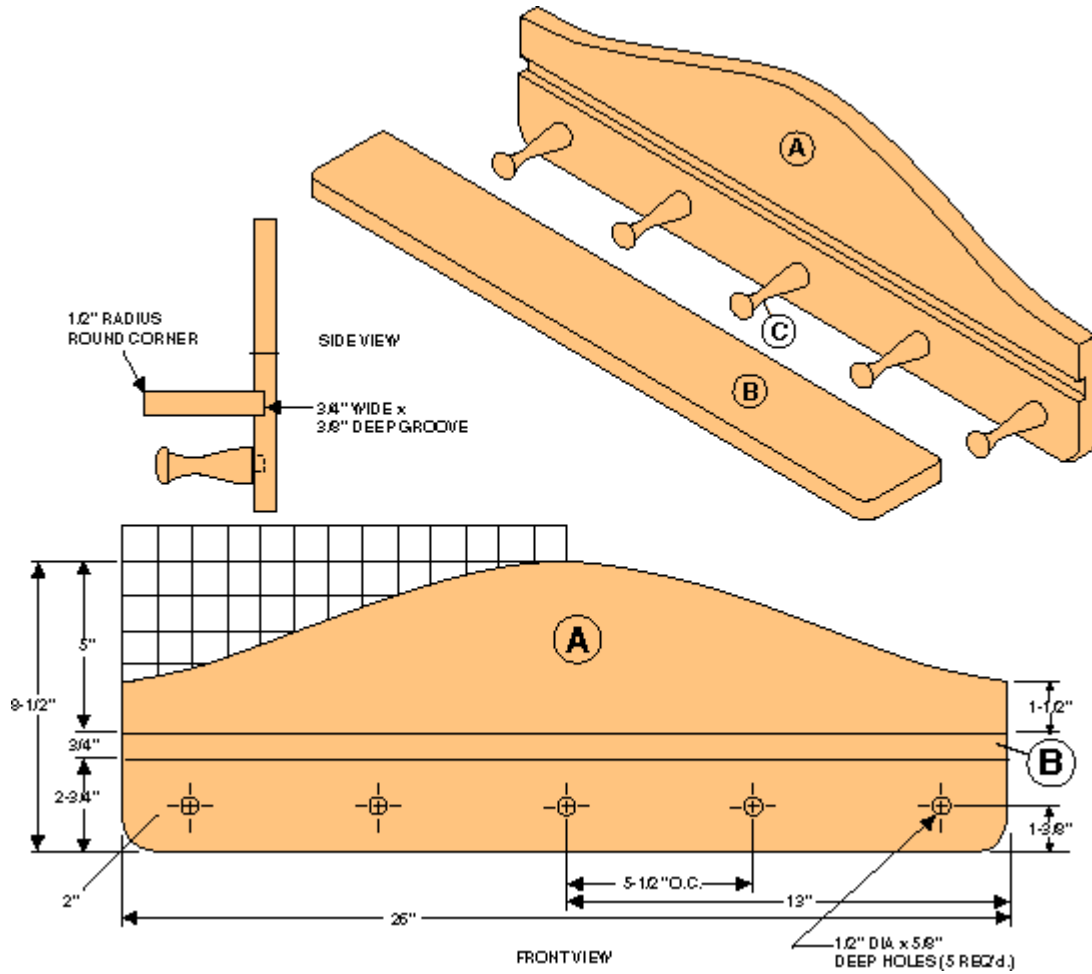

BASEBALL EQUIPMENT HOLDER



Here's a clever little item that's perfect for holding any child's or adult's baseball, bat and glove. We talked to one flea market vendor who told us he sells these as fast as he can make them at around \$20 a piece.

We built ours from pine with birch shaker pegs, but you could also make them from oak, cherry or other, "higher-class" woods and sell them for even more money.

To make these, you'll need a scroll saw or bandsaw, a drill press (with 1/8" and 1/2" diameter bits), a pad sander and a drum sander.

1. Transfer the pattern below to a piece of cardboard using a 1/2" grid pattern. Cut out your template.
2. Trace your template onto a piece of 1/8" or 1/4" hardboard (Masonite) and mark the locations of the (5) peg holes and (20) rawhide lace holes.
3. Cut out your pattern using a scroll saw or bandsaw and a thin blade. **TAKE YOUR TIME** when cutting out your pattern to be sure it's just right and you don't bind the blade. Remember, the holders you make to sell will only be as well-done as the pattern you use to draw them out.
4. Drill 1/2" deep stopped holes at all marked peg and lace locations using a 1/8" bit.



5. Trace your pattern onto a 3/4" thick piece of stock. Use a nail or 1/8" bit in a portable drill to transfer all hole locations to your workpiece. **NOTE:** To save time when cutting, you can stack four or five blanks together with double-sided tape and "pad saw" them all at once using your bandsaw and a 1/16" blade. Or, if you prefer, you could pad saw up to two holders at once using your scroll saw.
6. Use a hand-held pad sander to smooth the surfaces of the glove, using 150 to 220-grit sandpaper.
7. Use your drill press and a drum sander to smooth the outer edges of the holder.
8. For wall mounting, attach screw eyes and a picture hanging wire...sawtooth hangers or picture hanging tabs to the back. As an option, you could use a router with a T-Slot Bit to create hanging slots in the back side.
9. Glue the pegs into place by applying glue sparingly to the holes and not the pegs.
10. Stain as desired and apply two coats of the finish of your choice, sanding lightly between coats.
11. Cut a rawhide shoe string to the appropriate lengths to criss-cross the fingers. Apply glue into the lace holes with a toothpick and insert the rawhide

Suggested retail price: \$20 to \$25, depending on wood used

The Baseball Equipment Holder

Plans

USE 1/2" GRID

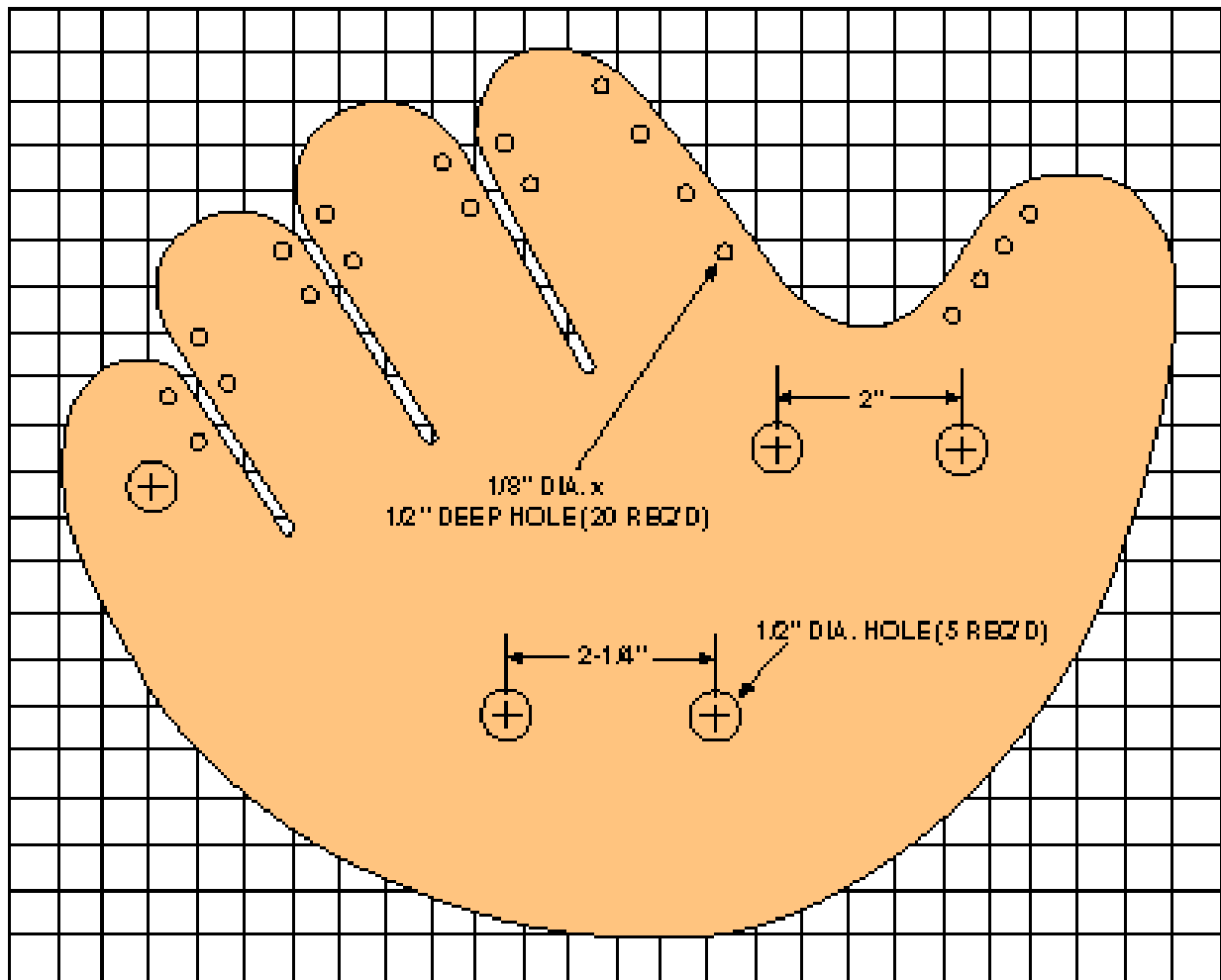



LIST OF MATERIALS

(finished dimensions in inches)

Glove (1)	3/4 x 9-1/2 x 12
Shaker pegs(5)	
36" of rawhide shoestring	

FOUR POSTER BED



If you've recently gone shopping for a top-quality four-poster bed, you've already discovered how expensive one of these "beauties" can be - especially if they're made of hard maple or cherry, like our example.

Here's your chance to save a bundle on the four-poster you've always wanted...and be sure it meets all your stringent quality requirements...because you crafted it with your own two hands.

The plans shown here are for a twin-sized bed, however, by simply enlarging the frame and headboard dimensions, you can make it any size you like...all the way up to King. You can even change the post profiles, if you like to make this bed truly your own.

Headboard and Frame

1: Start by gluing-up the stock for your Headboard (A), according to the list of materials. Be sure to joint all edges first and use a sufficient number of bar clamps to achieve a tight fit of all mating boards. Wipe off any excess glue squeeze-out immediately with a damp cloth and allow the joined boards to dry for a full 24 hours before proceeding.

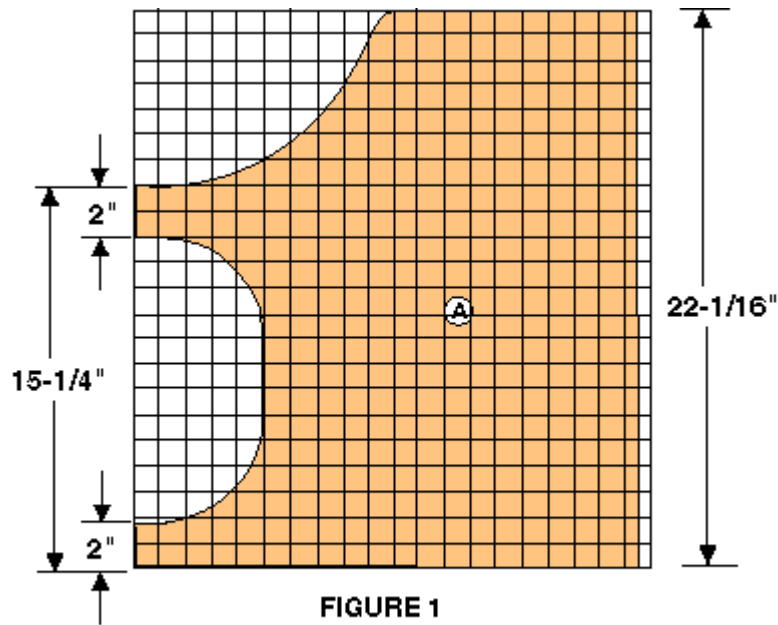

FIGURE 1
HEADBOARD
1 SQUARE = 1 INCH

2: Enlarge the pattern shown in figure 1 onto an appropriately sized piece of cardboard or stiff paper. Scrape off any remaining wood glue that you may have missed on the surface of your stock. Cut your pattern out and trace it onto your glued-up Headboard blank.

3: Using your bandsaw or a hand-held saber saw, cut out the Headboard shape.

4: Use a Drum Sander to smooth all edges on the headboard. Shoppersmith's special Oscillating Drum Sander will speed the process of achieving the super-smooth edges you need. Also, use a hand-held belt sander or pad sander to sand the front and back surfaces smooth.

5: Cut the Head and Foot Rails (B), Side Rails (C), Side Rail Cleats (D) and Slats (E) to size, according to the list of materials. **NOTE:** Remember that the sizes of these pieces will have to be altered if you're making a double, Queen or King-sized bed. If you're planning to make a Queen or King-sized bed, it would also be a good idea to make four or five slats, instead of the recommended three used in our twin-sized example.

6: Use your Dado set-up to cut the tenons on the ends of the Head and Foot Rails (B) (See Fig. 2), and Side Rails (C) (See Fig. 3).

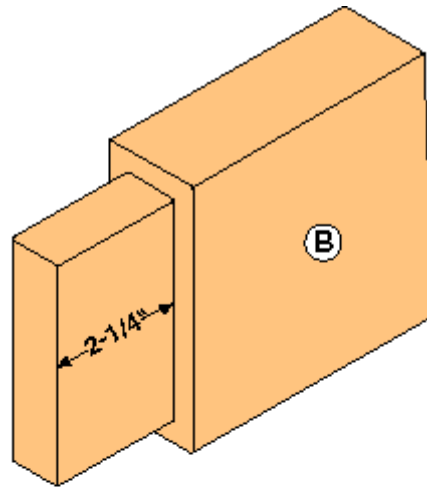
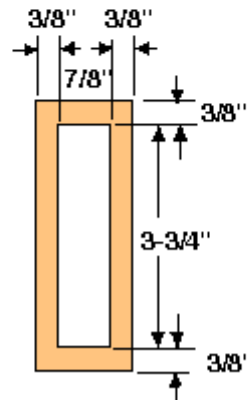

FIGURE 2
HEAD & FOOT
RAIL TENONS



SAME ON SIDE RAILS (C)
AND HEAD AND FOOT RAILS (B)

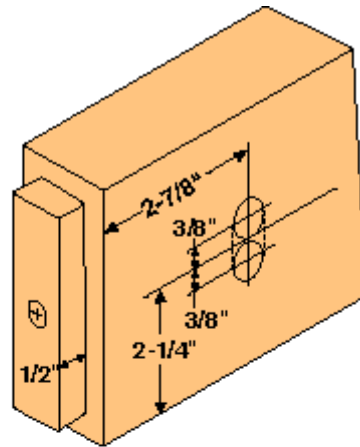
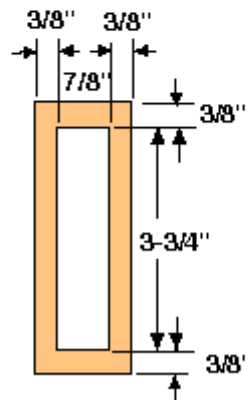
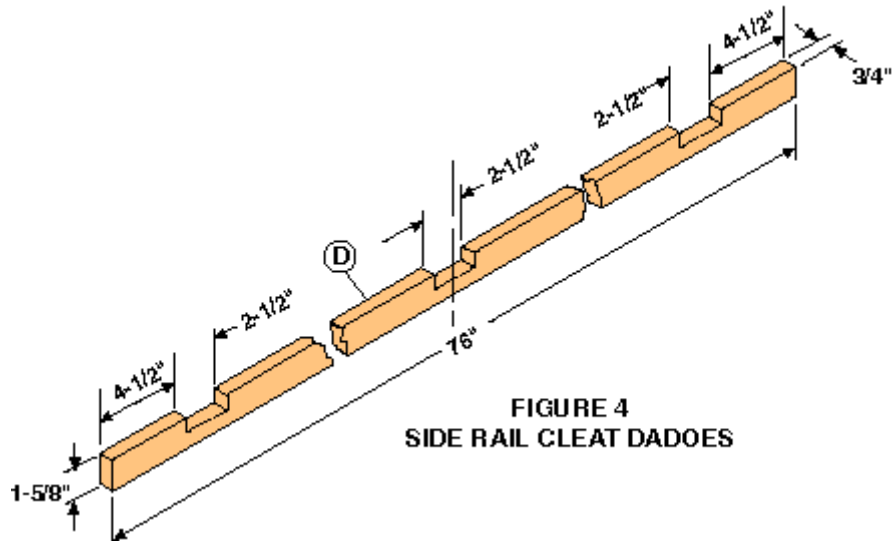

FIGURE 3
SIDE RAIL TENONS



SAME ON SIDE RAILS (C)
AND HEAD AND FOOT RAILS (B)

7: Cut the 3/4" deep x 2-1/2" wide dadoes in the Side Rail Cleats (D) to hold the Slats (E) (See Fig. 4). Remember that if you're planning to build a double, Queen or King-sized bed, you'll need to create four or five dadoes in these Cleats instead of three.



8: Using your Drill Press with a 3/4" Brad Point Bit, bore a 1-3/8" deep stopped hole on each side of the Side Rail centerline, as shown in Fig 3. Use a hand chisel to join these two holes into an oval that will accept the nuts for the 6" long bolts that will anchor the Side Rails (C) to the posts (F) during assembly. **NOTE:** If you prefer, these recesses can also be created using a Hollow Chisel Mortising Package in lieu of drill bits and a hand chisel.

Posts

1: Cut out and square the ten sections of turning stock that will be used for the Posts (F & G) and the Blanket Rail (H & I), according to the list of materials.

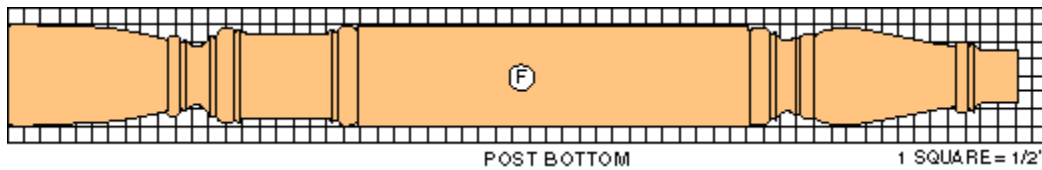
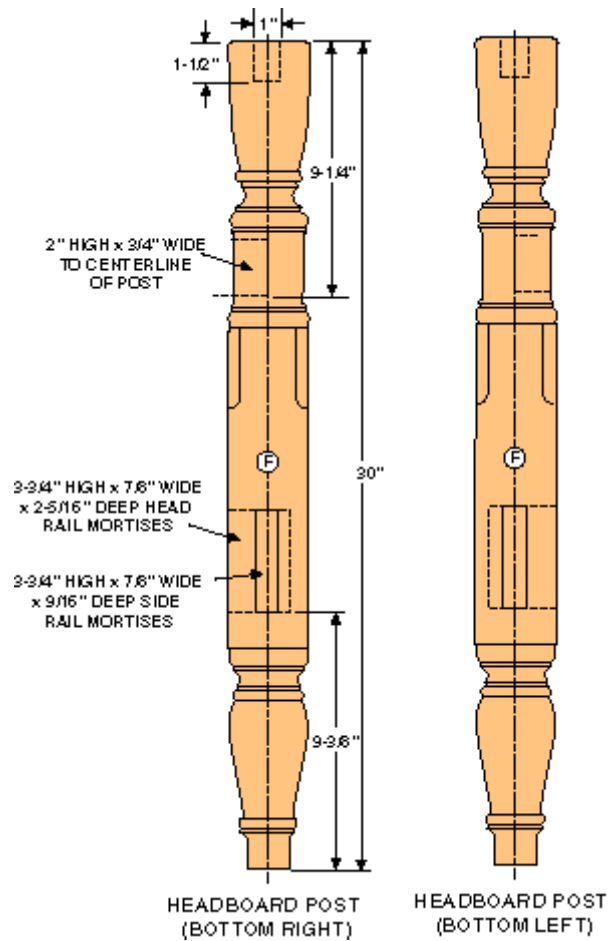

2: Locate the centers of the ends on all ten sections of turning stock. Using a straightedge, draw lines from corner-to-corner to find the exact centers.

3: Using pieces of fairly heavy cardboard stock, create the patterns for the Posts (F & G) and Blanket Rail (H & I), by following the pattern drawings, provided. If you're going to use Outside Calipers to control your cuts, you'll need to create the entire profile for each turning, as shown on the patterns. However, if you're planning to use the Shopsmith Lathe Duplicator to be sure all components match perfectly, you need only create half of each pattern. Then, you'll transfer that pattern to a piece of 1/8" to 1/4" thick hardboard to use as a template that you'll follow when turning your pieces. See your Duplicator Owner's Manual for valuable pattern-making tips. **NOTE:** Again, if

you're making a double, Queen or King-sized Bed, the lengths of your Blanket Rail pieces (H & I) will have to be modified to fit the wider Bed Frame.

4: Turn the upper and lower sections of the Posts (F & G). **IMPORTANT:** Be sure not to turn the balls on the top section down so small that your workpiece will snap off during turning. You can finish these balls a little later. Finish sand each section while its still mounted on the lathe.

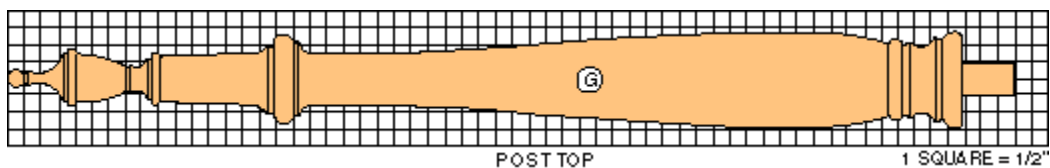
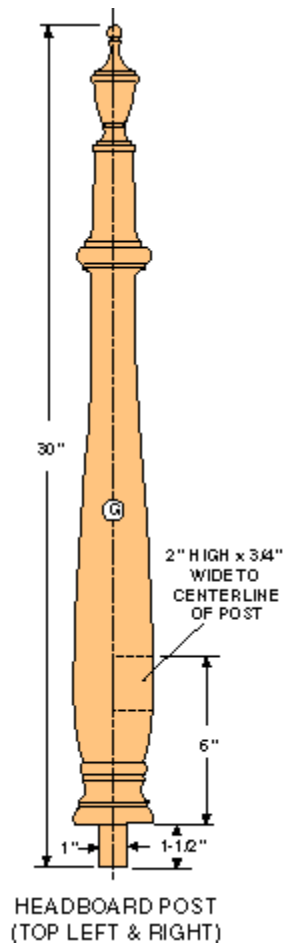

5: Turn both sections of your Blanket Rail (H & I) (See Fig. 6). Finish sand each section while it's still mounted in the lathe.

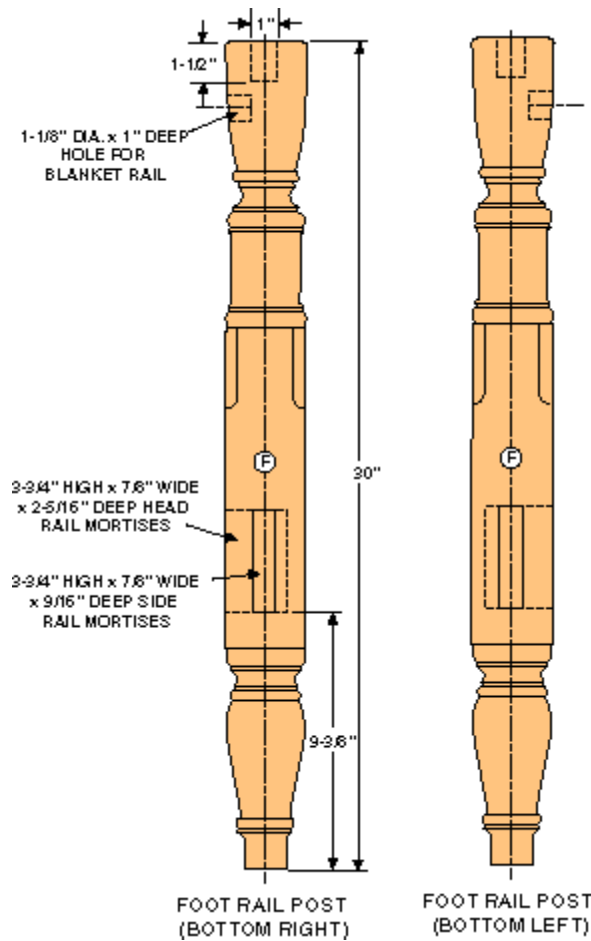

6: To finish the balls on the tops of the Posts (G), cut off the waste stock. Round over the balls using a double-cut wood file, then sand them smooth.

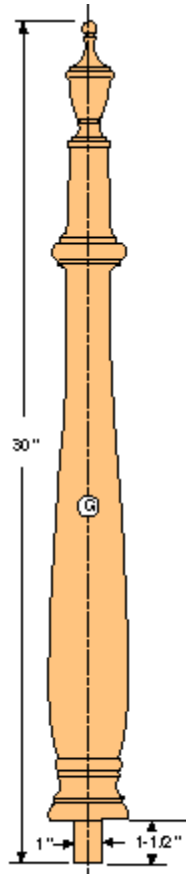

FOOT RAIL POST
(TOP LEFT & RIGHT)

7: Set up your MARK V for Horizontal Boring and drill the 1" diameter x 1-1/2" deep holes in the bottom sections of your Posts (F). These holes will accept the 1" diameter "tenons" you turned on the upper sections of the Posts. Tilt your MARK V Worktable to 45-degrees and use your Rip Fence to form a V-block for holding the Posts while you drill these holes. Bore a 1" diameter x 2-3/8" deep hole in the end of one of your Blanket Rail Spindle halves (See Fig. 6).

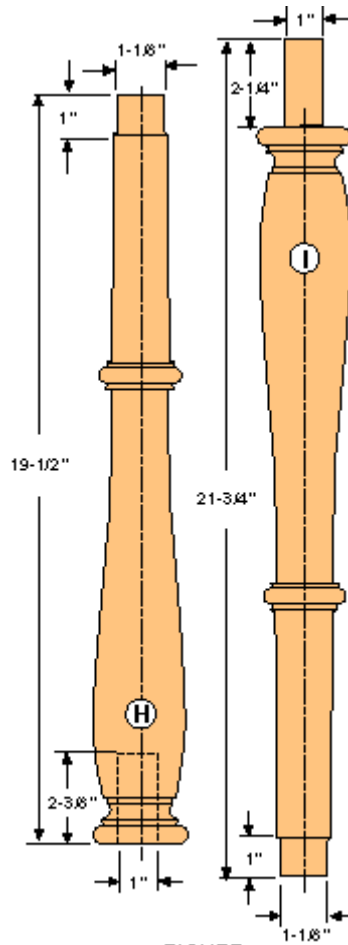
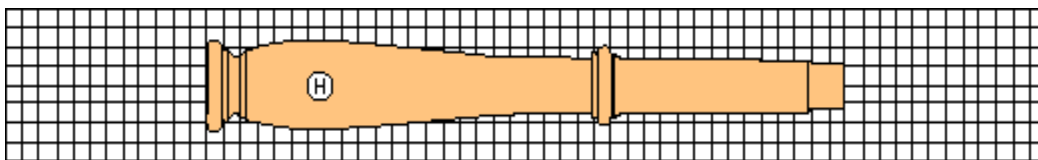

FIGURE 6
BLANKET RAIL SPINDLES



BLANKET RAIL
1 SQUARE = 1/2"

8: Assemble and glue all Post (F & G) and Blanket Rail (H & I) sections together and set aside to dry for 24 hours.

9: Label all Posts (HBR, HBL, FBL, FBR) to be sure you position the mortises in the proper locations during step 10, to follow.

10: Use a 7/8" Brad Point Bit or a Hollow Chisel Mortising set-up with a 1/2" Bit & Chisel set to create the Headboard and Foot Rail Post (F & G) mortises described here: a: 3-3/4" high x 7/8" wide x 9/16" deep mortises for the

Side Rails (C) b: 3-3/4" high x 7/8" wide x 2-5/16" deep mortises for the Head & Foot Rails (B) c: 2" high x 3/4" wide mortises to the centerline of the Posts (F & G) for the Headboard (A)

11: Drill 1-1/8" diameter x 1" deep holes in the two Foot Rail Posts (F). These will accept the outer ends of the Blanket Rail

Assembly

1: Using a portable drill, create 3/4" deep counterbores for the heads of your 3/8" x 6" assembly bolts in the bottoms (flat sections) of the Posts (F). Be sure these counterbores are a large enough diameter to accommodate the flat washers under the heads of your 6" long assembly bolts. Then, dry assemble the Head and Foot Rails (B) to the Posts (F). Use long bar or pipe clamps to hold the rails in position while you bore 3/8" diameter holes all the way through the four Posts (F) and the tenons in each end of the two Rails (B). (See Fig. 7)

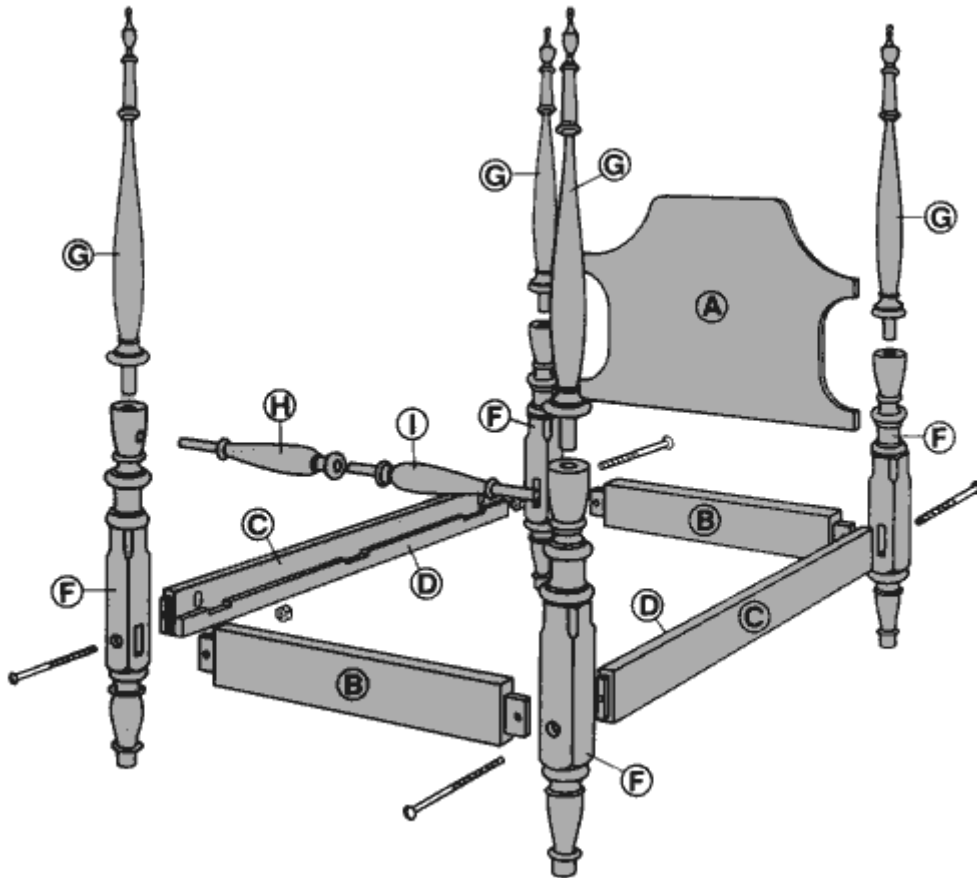

FIGURE 7



2: Disassemble these components and use your Horizontal Boring set-up with a 3/8" diameter bit to bore 4-3/8" deep holes into the ends of the Side Rails (C). For proper positioning, see Figures 3 and 7. These four holes should break through one side of the mortises you created in the Side Rails (C) in step 8 under "Headboard and Frame" at the beginning of this article. During assembly, your bolts will go through the four Posts (F) and into the ends of the Side Rails (C). The mating nuts will be positioned within the mortises and when the bolts are tightened, the Rails (C) will be drawn tightly into the Posts (F).

3: Glue the Side Rail Cleats (D) to the inside bottom of the Side Rails (C). For extra strength, add six 1-1/2" long #8 roundhead wood screws, spaced evenly along the length of each Cleat. (See Fig. 7)

4: Glue the Headboard (A) and Head Rail (B) to the Headboard Posts (F & G).

5: Glue the Blanket Rail (H & I) and the Foot Rail (B) to the Footboard Posts (F), (See Fig. 7)

6: Finish to suit your decor.

7: Attach the Side Rails (C) to the Headboard and Footboard assemblies with the 6" bolts and nuts. Drop the slats into the notches you formed in the Side Rail Cleats (D). (See Fig. 7) Cover the bolt heads with decorative hardware.



LIST OF MATERIALS

(finished dimensions in inches)

A	Headboard	3/4 x 22-1/16 x 39-3/4 *
B	Head & Foot Rails (2)	1-5/8 x 4-1/2 x 41-1/4 *
C	Side Rails (2)	1-5/8 x 4-1/2 x 77 *
D	Side Rail Cleats (2)	3/4 x 1-5/8 x 76 *
E	Slats (3)*	3/4 x 2-1/2 x 38 *
F	Posts -bottom - (4)	3 x 3 x 30
G	Posts - top - (4)	3 x 3 x 30
H	Blanket Rail (1)	2-1/2 x 2-1/2 x 19-1/2 *
I	Blanket Rail with tenon (1)	2-1/2 x 2-1/2 x 21-3/4*

HARDWARE

- (4) 3/8" dia. x 6" long bolts with nuts and flat washers
- (12) 1-1/2" long #8 roundhead wood screws
- (4) Decorative bolt head covers

*** These dimensions must change if you're building a bed that's larger than twin size**

SECRET COMPARTMENT PAPER TOWEL HOLDER

Here's a quick, easy-to-make paper towel rack that's unlike any you'll find elsewhere



Many small jobs around the house can't be done in the shop. Instead, they often have to occur on-site. That means going to the shop to get the tools needed to do the job. However, this special paper towel rack gives your craft fair and flea market customers the perfect place to stash away a small tack hammer, a screwdriver or two and a pair of pliers. It's also great for sewing supplies...a small pad of note paper and a pencil...the car keys...or what have you. In short, it's a "multi-purpose" towel rack that's unique enough that it'll put you well ahead of your competitors at shows...and help you "wipe-up" the profits!

- 1:** Cut all parts (A,B,C,D,F) to size, according to the list of materials.
- 2:** Transfer the patterns from the drawings to your stock and cut out all contours with your Bandsaw. To save time, you can attach four of each piece together with double-stick tape and pad saw them all simultaneously. Use your drum sander and disc sander to smooth all the edges. Here's another time-saving trick - Shopsmith's Oscillating Drum Sander Attachment can be adjusted to provide up to 3/4" of up-down travel...more than enough to make quicker work of sanding the internal curves on a stack of up to four identical 3/4" thick pieces.
- 3:** Drill the 1" dia. holes in the sides to accept the towel bar.
- 4:** Set up your Shopsmith Router Package and use the special "3-in-1" Router Bit and the 1/4" Router Chuck to make your initial 1/2" deep cuts around the inside perimeters of the top and lid. Guide your workpieces against your rip fence for added control when making these cuts. Once you've cut the first groove around the perimeter of both pieces, switch to a 3/4" straight router bit, re-adjust your rip fence and your depth-of-cut to remove the balance of the center waste.



5: Turn the handles (E) on the lathe. If you have a Shopsmith Lathe Duplicator, you can follow the directions in your Duplicator Owner's Manual and make a duplicator template that will allow you to turn up to 7 or 8 handles from a single long piece of stock..

6: Cut the handles apart with your bandsaw and drill a 15/16" diameter x 3/4" deep hole in the end of each handle for the 1" towel bar. Sand the ends of the towel bar (F) on your disc sander until you achieve a snug fit on the handles.

7: Use a rounding-over router bit or quarter-round shaper cutter to smooth over all edges.

8: Assemble the towel holder by attaching the sides (A) to the back (B) with #8 x 1-1/2" flathead wood screws. Use 4-penny finishing nails and glue to attach the top (C) to the sides. Attach the lid (D) to the back with hinges. Sand the holder and apply the finish of your choice.

Suggested retail price: \$20 to \$25

LIST OF MATERIALS

(finished dimensions in inches)

A	Sides (2)	3/4 x 6-1/4 x 6-1/4
B	Back	3/4 x 8-1/2 x 15-1/2
C	Top	3/4 x 7 x 15-1/2
D	Lid	3/4 x 7 x 15-1/2
E	Handles (2)	1-3/4 dia. x 4
F	Towel Bar	1 dia. x 14-1/4
Miscellaneous		
(4)	#8 x 1-1/2" Wood screws	
(4)	4-penny finishing nails	
(2)	Small leaf hinges w/screws	

Side View

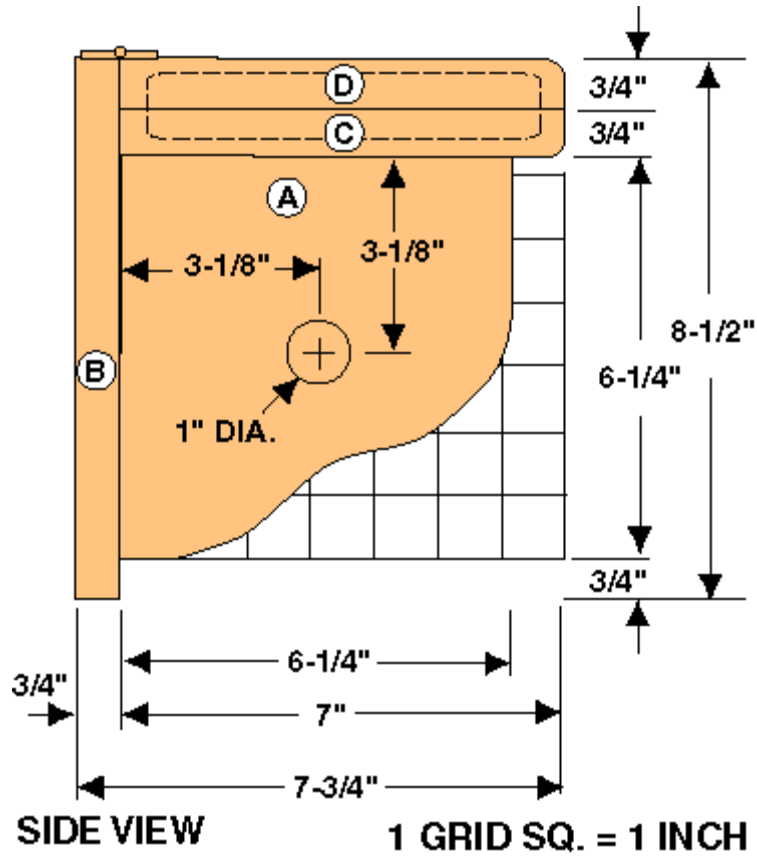

Front View

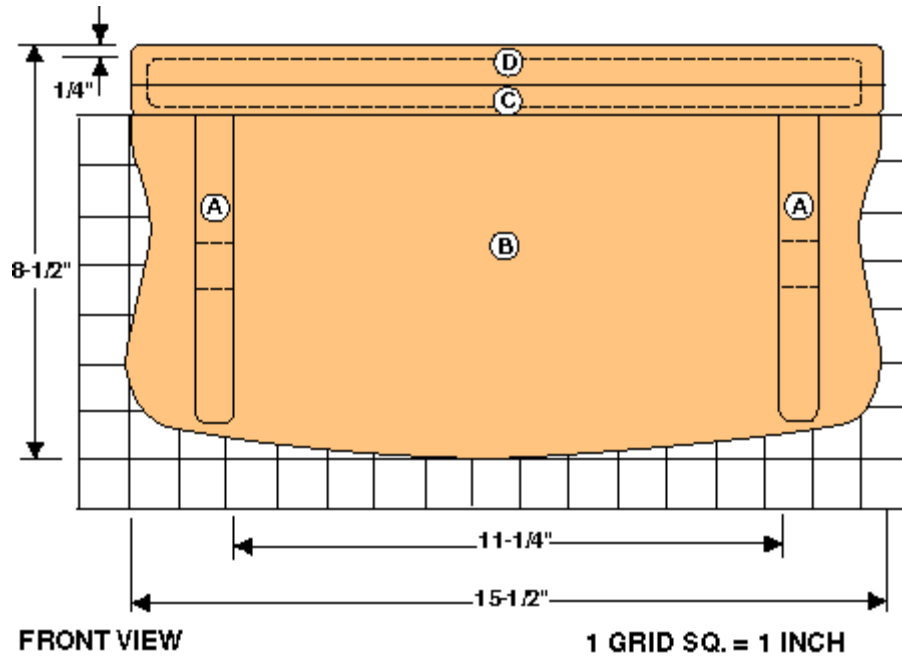

Handle Detail

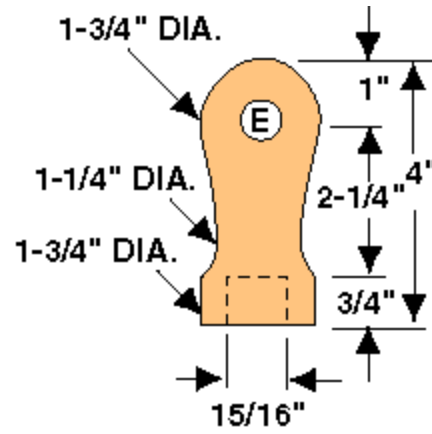

HANDLE DETAIL

Top and Lid Detail

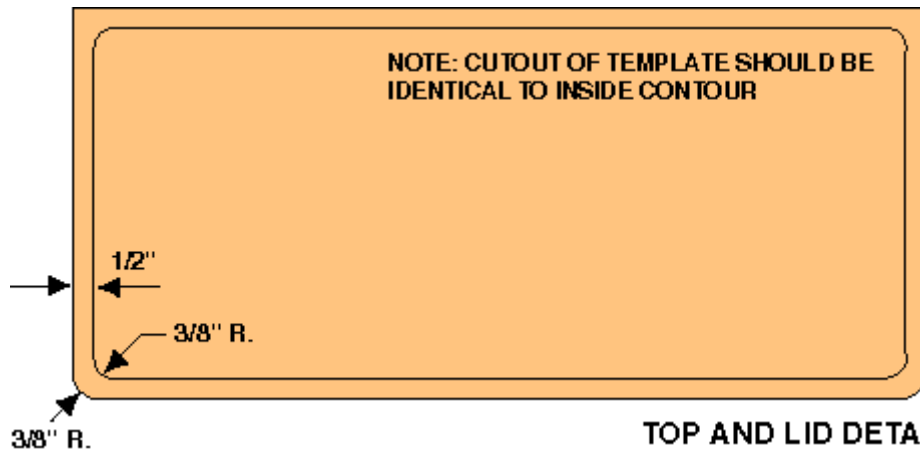

TOP AND LID DETAIL

Assembly

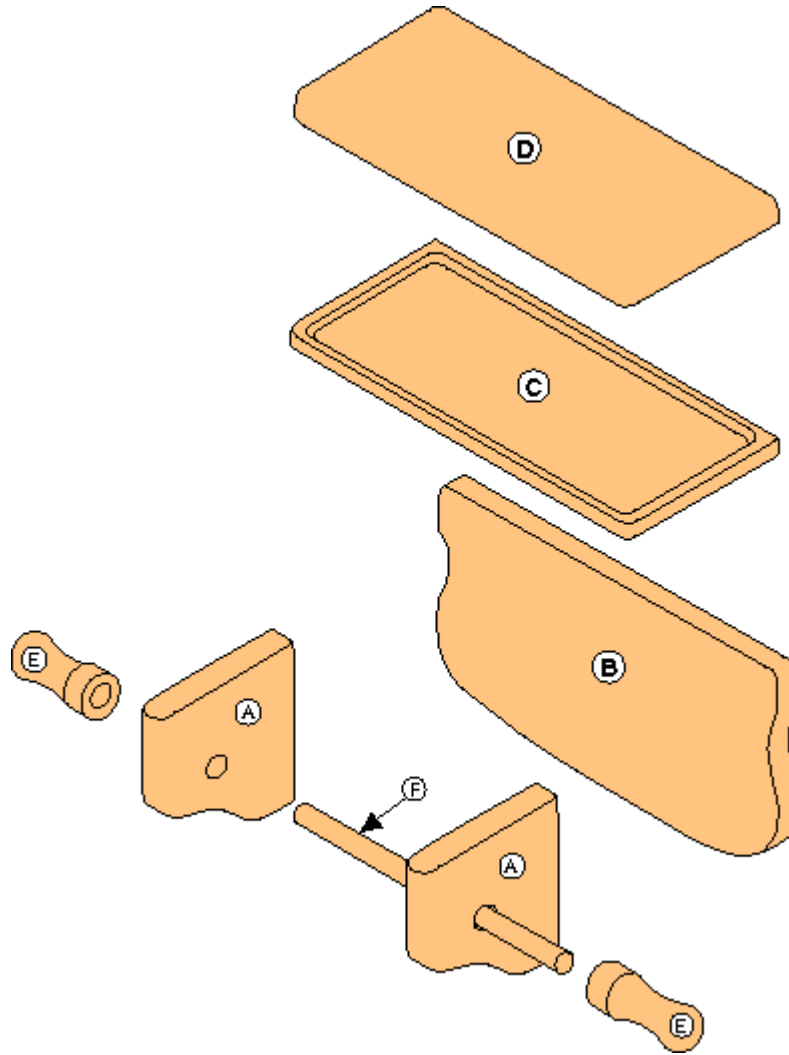

HEIRLOOM TOY TRAIN

A five-car Train that's loads of fun for you to build -- and durable enough to be around for your grandchildren and great-grandchildren to enjoy



We've been told that the first toy train appeared in the 1820's - just a few short years after the first real train carried its first passengers and hauled its first load of freight. As the railroads grew and the design of locomotives evolved and diversified, so did the toy train. But even today, the favorite of kids everywhere remains the classic 4-4-0 from the Golden Age of Steam. So, with a puff of steam and a hearty tug of the whistle, we're off!

The Locomotive

1. Start by cutting all the pieces to the proper size and shape, using the gridded patterns we've provided. Drill 7/16" dia. axle holes in the Wheel Mounts (D&E) and a 7/16" dia. hole in the Engine Coupler (F). Refer to the patterns for the correct positions of these holes. Drill 3/8" dia. holes in the centers of the Wheels (L&M). Using your Lathe, turn the Pistons (N), Boiler (O), Smokestack (P) and Pressure Dome (Q).
2. Glue up the Platform Sections (A,B&C), referring to the pattern for proper positioning. Cut the Cow Catcher using a compound cut on your Table Saw - Set your MARK V Table tilt to 30-degrees and your Miter Gauge to 60-degrees.



Cut the cowcatcher when the upper, Mid and Lower Platform (A, B, & C) have been glued up. The table is tilted at 30°; the miter gauge at 60°.

3. Tilt your MARK V's Table to 15-degrees and cut the top edges of the Upper Cab Sides (I) to accept the tilted Roof. Glue the Upper Cab Sides (I) to the Lower Cab Sides (J), referring to the pattern and exploded view for proper positioning. Be sure the lower Cab Sides protrude 3/4" below the Upper Cab Sides when assembled.



Glue the Cab Sides to the Firewall (H). With your MARK V's Table still tilted to 15-degrees, cut the mating inside edges of the Cab Roof (K) to create the proper Roof pitch. Glue the two halves of the Roof together, then glue the entire Roof assembly to the top of the assembled Cab. For added strength, these (and all) component joints can be reinforced with dowels or screws.

4. Glue the turned Boiler (O) to the Boiler Mounts (G). Reinforce these glue joints with countersunk flathead screws, driven up through the bottoms of the Mounts and into the Boiler.

Drill shallow, 1" dia. holes in the Top of the Boiler to accept the Smokestack (P) and Pressure Dome (Q). Refer to the pattern for proper positioning.

5. Temporarily, assemble the Wheels to their Mounts. Position the wheel assemblies under the Platform and the Boiler and Cab assemblies on top of the Platform. The back of the Drive Wheels (M) should be flush with the back of the Cab and the Truck Wheels (L) must not rub against the CowCatcher. Once you're comfortable that you have all of the assemblies aligned properly, mark for position and disassemble them.

6. Glue on the Boiler and Cab assemblies and reinforce them with dowels or screws, as you prefer.

7. Glue the Truck Wheel Mounts (D), Drive Wheel Mounts (E) and Engine Coupler (F) to the Platform. Take care to be sure the axle holes line up properly. Refer to the pattern for the position of the Coupler. Reinforce with dowels or screws, as you prefer.



The underside of the engine, showing the reinforcing screws before they are covered with dowels.

8. Insert the Axles (R) through their Wheel Mounts (D&E) and glue the Wheels onto the ends, being careful not to allow excess glue or squeeze-out to touch the Mounts.



9. Using a Sander or rasp, create a 3/4" wide flat spot on the Pistons (N) and glue them into position on the edge of the Platform (A), above the Rear Truck Wheels (L). Reinforce with dowels or screws, as you prefer.

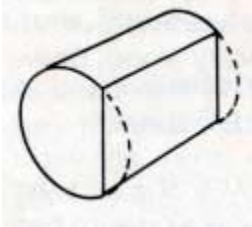

10. Glue the Smokestack (P) and Pressure Dome (Q) into the holes in the top of the Boiler (O)

The Coal Car

1. Cut all pieces to their sizes and shapes, following the patterns provided. Drill 7/16" dia. axle holes in the Drive Wheel Mounts (E), a 7/16" dia. hole in the Car Coupler (U) and 3/8" dia. holes in the Coal Car Platform (V) and the centers of the Truck Wheels (L). Refer to the pattern for proper hole positioning.
2. Glue the Coal Car Sides (W) to the Coal Car Back (X), then glue the Coal Car Assembly to the Coal Car Platform (V) and reinforce with dowels or screws, as you prefer.
3. Glue the Drive Wheel Mounts (E) to the Coal Car Truck Mount (T), taking care that the axle holes line up properly. Glue the Car Coupler (U) to the Coal Car Assembly, referring to the pattern for position. Reinforce with dowels or screws, as you prefer.
4. **Temporarily** assemble the Wheels to their Mounts. Place the Coal Car Assembly on the Truck Assembly and mark for position. Be sure the Wheels don't rub on the Car Coupler (U). Disassemble.
5. Glue the Truck Assembly to the Coal Car Assembly. Reinforce with dowels or screws, as you prefer. Insert Axles (R) through the Mounts and glue the Truck Wheels (L) onto the ends, being careful not to allow excess glue or squeeze-out to touch the Mounts. Glue Coupler Pin (S) into the hole on the Coal Car Platform (V). The Pin should extend 3/4" below the Platform.



The Basic Car

Many different Cars can be made to follow the Locomotive and Coal Car, all mounted on a Basic Car Assembly.



The basic car and a bottom view of a basic truck assembly

1. Cut all pieces to proper size and shape, following the patterns provided. Drill $7/16$ " dia. axle holes in Truck Wheel Mounts (D), a $7/16$ " dia. hole in Car Coupler (U) and $3/8$ " dia. holes in the Car Platform (Z) and the centers of each Truck Wheel (L). Refer to the pattern for proper positions.
2. Glue Special Car Assembly (Log Car, Box Car, etc.) to Car Platform (Z) before assembling the Basic Car.
3. Glue Truck Wheel Mounts (D) to Truck Mounts (Y), taking care that Axle holes line up properly. Glue Car Coupler (U) to Car Platform (Z). Refer to pattern for proper position. Reinforce with dowels or screws, as you prefer.
4. **Temporarily** assemble Wheels to Mounts. Place Car Assembly on top of Truck Assemblies and mark for position., Truck Mounts (Y) should be approximately 2-1/4" apart and Wheels should not rub on Coupler. Disassemble.
5. Glue Truck Assemblies in position and reinforce with dowels or screws, as you prefer. Insert Axles (R) through the Mounts and glue Wheels (L) onto the Axle ends, being careful not to allow excess glue or squeeze-out to touch the Mounts. Glue Coupler Pin (S) in hole in Car Platform (Z). Pin should extend $3/4$ " below Platform.

Design and build as many cars for the Train as your child can push along. Here are three suggestions:

The Flat Car

1. Cut the basic car pieces and 10 extra axles. Drill ten $3/8$ " dia. holes in the Car Platform (Z) for the vertical Axles. Holes should be spaced $2-3/16$ " apart in two rows, 3" apart, $3/8$ " in from either edge of the Platform.
2. Glue Axles (R) into these holes, protruding above the Platform as shown.



3. Assemble the Basic Car.

The Box Car

Cut out the Basic Car Pieces plus the pieces listed for the Box Car.

- 1.** Cut out the Basic Car pieces, plus the pieces listed for the Box Car.
- 2.** Glue the Box Car Sides (DD) to the Car Front and Back (CC). Reinforce with dowels or screws, as you prefer. Glue Box Car Side/Front/Back Assemblies to Platform (Z), leaving a 3" space between Assemblies for the Doors. Reinforce with dowels or screws, as you prefer.
- 3.** Cut a 5/16" rabbet, 5/16" deep in the tops and bottoms of the Car Doors (EE). Drill a 3/8" dia. hole, midway up the Door sides and 3/8" in from one side for the Door Pulls, as shown.

Glue the Door Pulls (HH) into these holes with the ends protruding from the sides opposite the rabbets.

- 4.** Glue two inside Door Slides (FF) to the Car Platform (Z), 1/2" in from the Box Car Sides (DD). Position the Doors in place with the rabbets riding on the Slides. Repeat this process for the opposite side of the Car Platform.

Repeat the steps above for affixing the Door Slides (FF) to the underside of the Box Car Top (AA). Set the Top (AA) into position with the Doors riding in the Slides and check to be sure the Doors slide properly.

- 5.** Spread a liberal amount of glue on the top of the Box Car Sides, Front, Back and Upper Inside Door Slides and glue the Car Top (AA) in place. Reinforce with dowels or screws, as you prefer.

Glue the Top Rail (BB) down the middle of the Car Top (AA). Glue the Outside Door Slides (GG) to the Car Platform (Z), the inside edge flush with the inside edge of the Box Car Sides (DD).

- 6.** Assemble the Basic Car.



The Pullman

1. Cut out the Basic Car pieces and the pieces listed for the Pullman Car, using the patterns provided.



The windows in the Upper Cab Sides (I) and the Pullman Sides (II) can be cut with a scroll saw or coping saw, using an internal piercing cut.

2. Glue the Car Front and Back (CC) to the Pullman Sides (II). Glue the Car Top (AA) to the Pullman Assembly. The Top should overhang the Car Front and Back by 1-7/8". Reinforce with dowels or screws, as you prefer. Glue Top Rail (BB) down the middle of the Car Top (AA).

3. **Temporarily** position the Pullman Assembly and Observation Railings (JJ) on the Car Platform. The Railings should be 1-1/8" away from the Car Front and Back. Mark for position, then glue in place and reinforce with dowels or screws, as you prefer.

4. Assemble the Basic Car.

Finishing:

We recommend that you finish your Toy Train with a non-toxic Salad Bowl Finish. If you build a long Train - a Locomotive and several cars - you may find it timesaving to cut the pieces (wheels, mounts, platforms, etc.) all at once. Look over the Bills of Materials, add up the number and types of pieces you'll need, then set up your MARK V for "mass production".

One more tip...When you finish assembling your Train, get down on the floor, hook the cars together and play with it to your heart's content. Once you give this to a child, you'll never have another opportunity to do so...unless you build another for yourself !

Locomotive

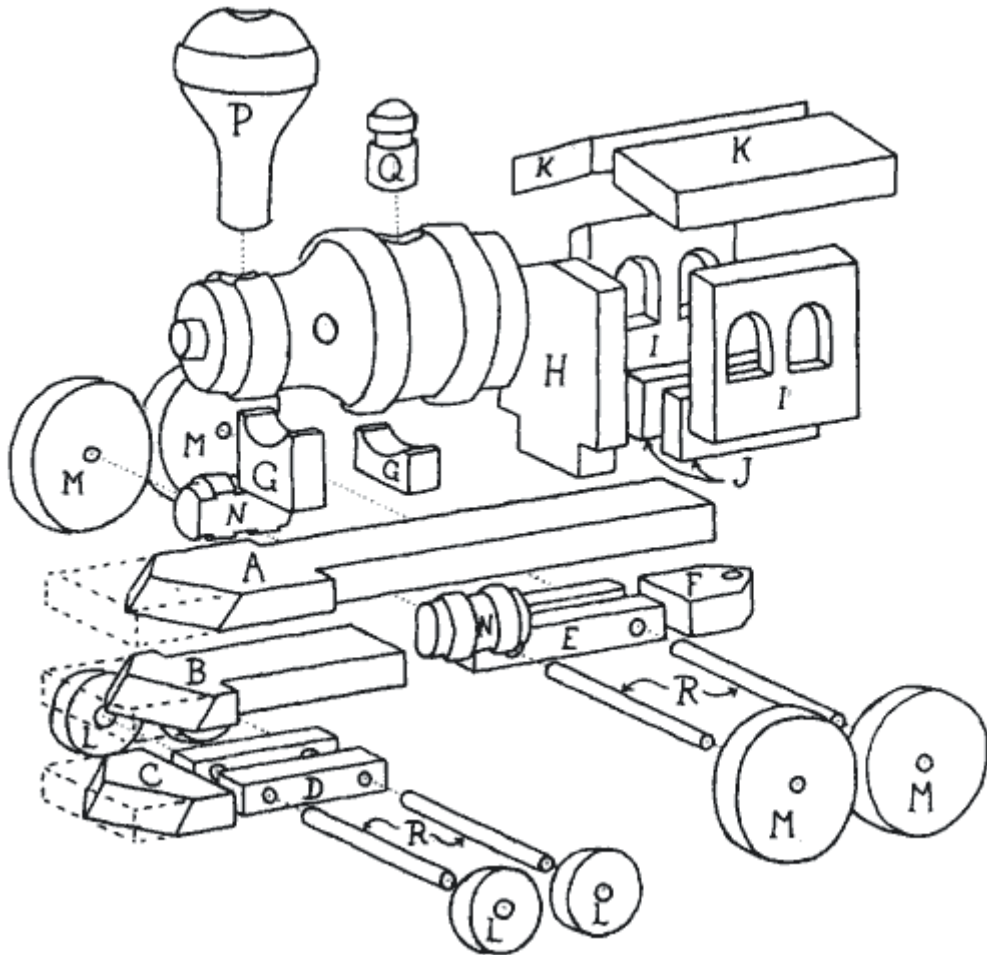

Coal Car

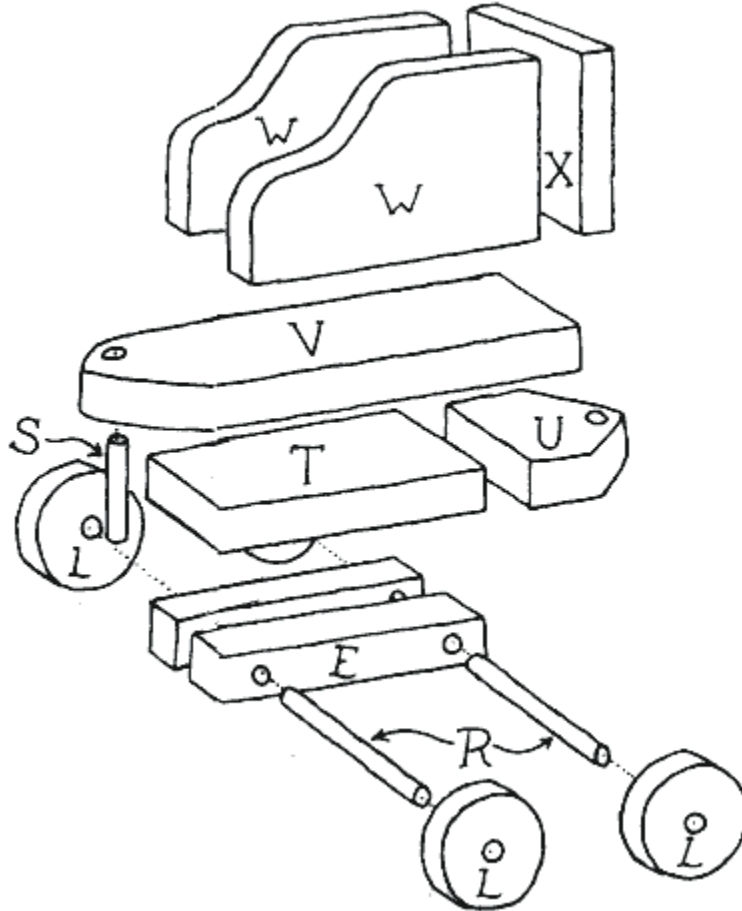

Basic Car

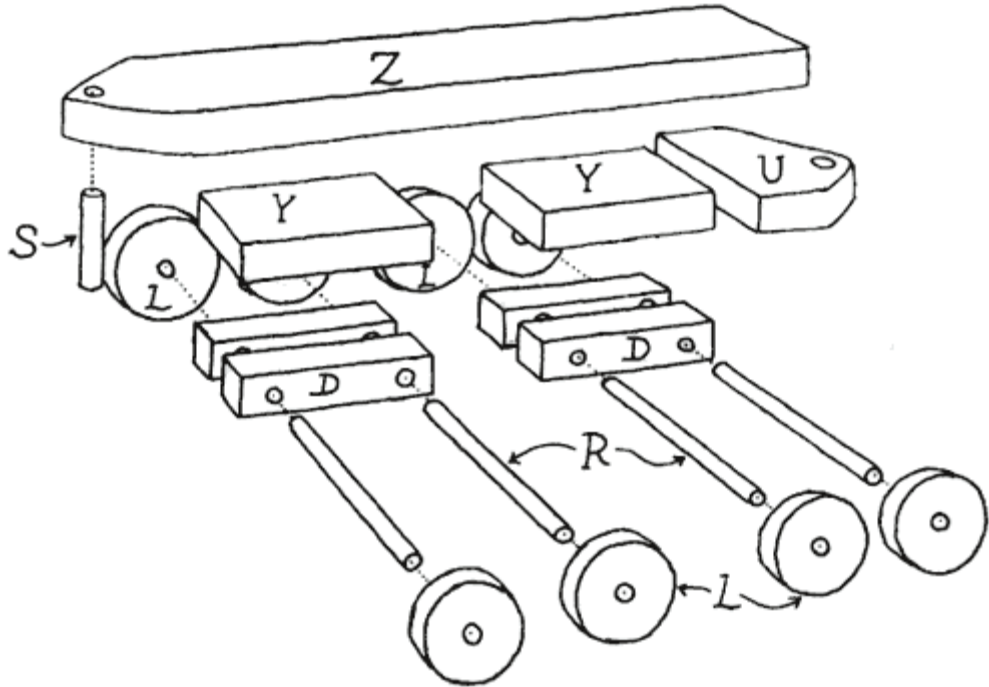

Flat Car

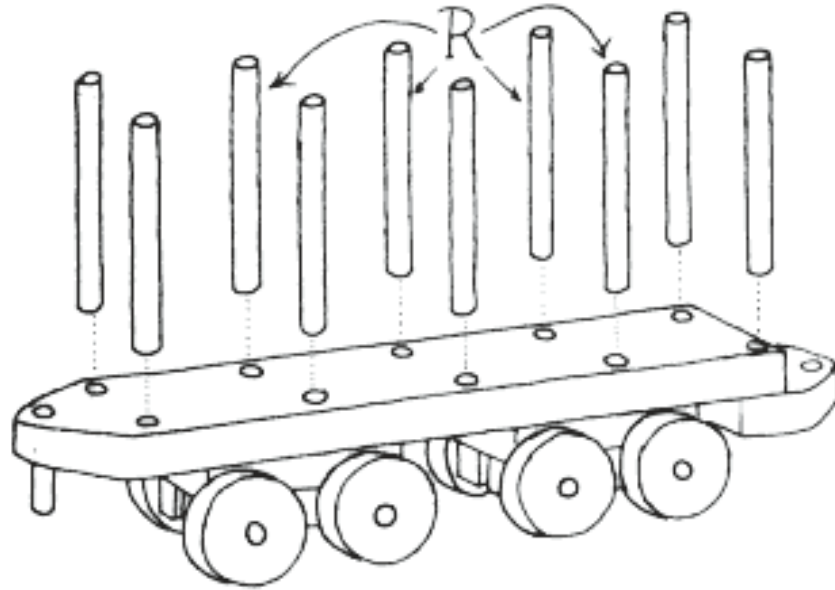

Pullman Car

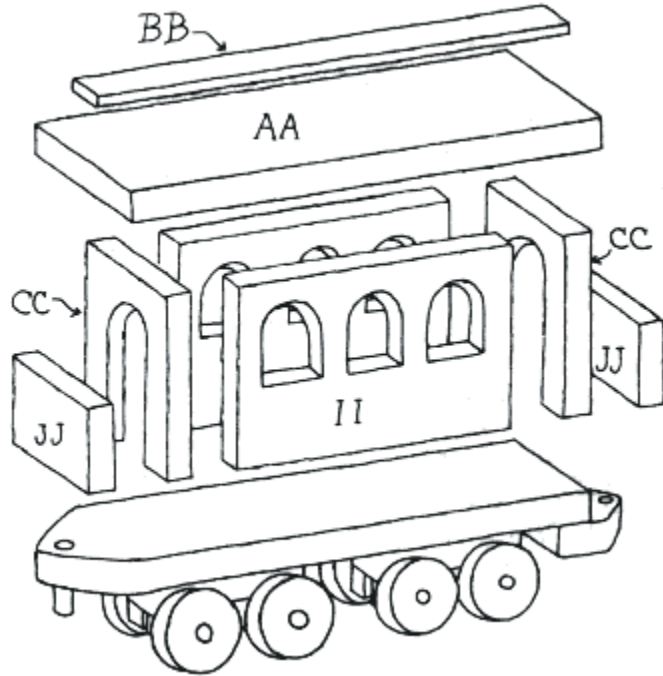

Plans

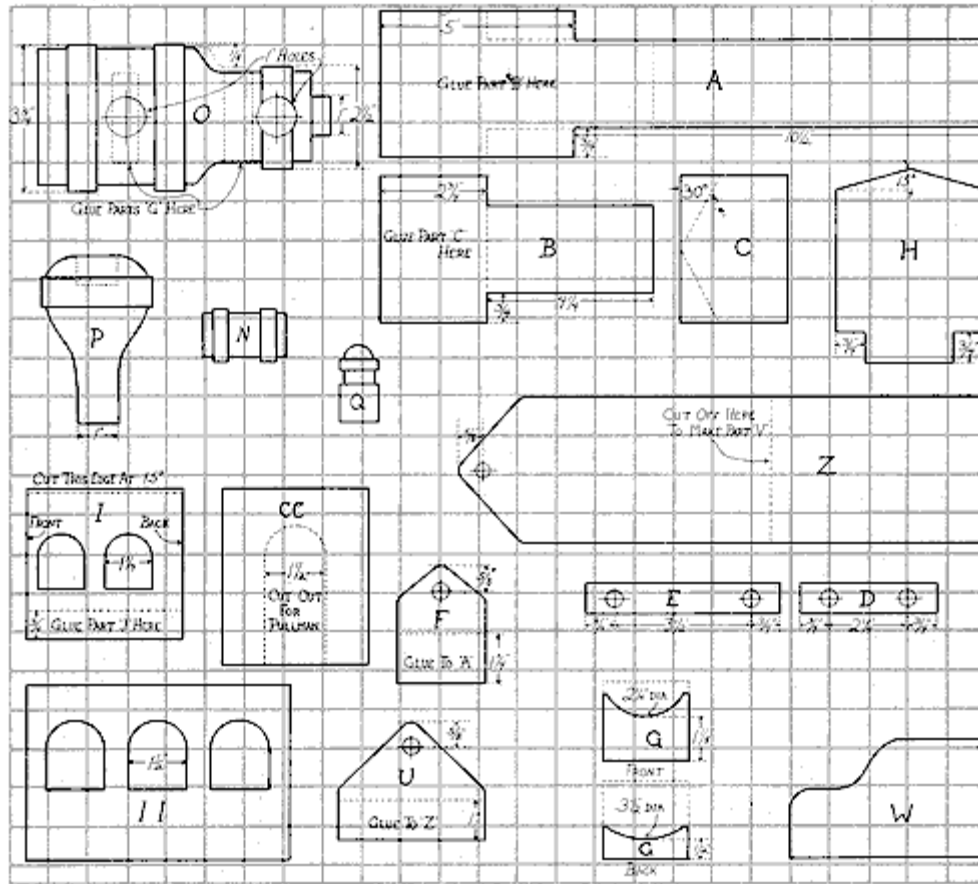



LIST OF MATERIALS

(all sizes in inches)

The Locomotive		
A	Upper Platform	15-1/2 x 3-3/4 x 3/4
B	Mid Platform	7 x 3-3/4 x 3/4
C	Lower Platform	2-3/4 x 3-3/4 x 3/4
D	Truck Wheel Mounts (2)	3-1/2 x 3/4 x 3/4
E	Drive Wheel Mounts (2)	5 x 3/4 x 3/4
F	Engine Coupler	3 x 2-1/4 x 3/4
G	Boiler Mounts (2)	2-1/4 x 2 x 3/4
H	Firewall	5 x 3-3/4 x 3/4
I	Upper Cab Sides (2)	4 x 3-7/7 x 3/4
J	Lower Cab Sides (2)	4 x 1-1/2 x 3/4
K	Cab Roof (2)	6-1/4 x 2-3/8 x 3/4
L	Truck Wheels (4)	3/4 x 1-3/4 dia.
M	Drive Wheels (4)	3/4 x 3-1/4 dia.
N	Pistons (2)	2-1/8 x 1-3/8 dia.
O	Boiler	7-1/2 x 3-3/4 dia.
P	Smokestack	4-1/4 x 2-3/4 dia.
Q	Pressure Dome	2 x 1 dia.
R	Axles	3-7/8 x 3/8 dia.

The Coal Car		
E	Drive Wheel Mounts (2)	5 x 3/4 x 3/4
L	Truck Wheels (4)	3/4 x 1-3/4 dia.
R	Axles (2)	3-7/8 x 3/8 dia.
S	Coupler Pin	1-1/2 x 3/8 dia.
T	Coal Car Truck Mount	5 x 2-1/4 x 3/4
U	Car Coupler	3 x 3-3/4 x 3/4
V	Coal Car Platform	8 x 3-3/4 x 3/4
W	Coal Car Sides (2)	5 x 3 x 3/4
X	Coal Car Back	3 x 3-3/4 x 3/4



The Basic Car		
D	Truck Wheel Mounts (4)	3-1/2 x 3/4 x 3/4
L	Truck Wheels (8)	3/4 x 1-3/4 dia.
R	Axles (4)	3-7/8 x 3/8 dia.
S	Coupler Pin	1-1/2 x 3/8 dia.
U	Car Coupler	3 x 3-3/4 x 3/4
Y	Truck Mounts (2)	3-1/2 x 2-1/4 x 3/4
Z	Car Platform	13-1/2 x 3-3/4 x 3/4

The Flat Car		
All materials listed for "Basic Car", plus...		
R	Axles (10)	3-7/8 x 3/8 dia.

The Box Car		
All materials listed for "Basic Car", plus...		
AA	Car Top	12 x 4 x 3/4
BB	Top Rail	11-1/2 x 1/4 x 3/4
CC	Car Front/Back(2)	4-1/2 x 3-3/4 x 3/4
DD	Box Car Sides(4)	4-1/2 x 3 x 3/4
EE	Box Car Doors(2)	4-7/16 x 3-1/2 x 3/4
FF	Inside Door Sides (4)	9 x 1/4 x 1/4
GG	Outside Door Sides(2)	3 x 1/4 x 1/4.
HH	Door Pulls (2)	1 x 3/8 dia.

The Pullman		
All materials listed for "Basic Car", plus...		
AA	Car Top	12 x 4 x 3/4
BB	Top Rail	11-1/2 x 1/4 x 3/4
CC	Car Front/Back(2)	4-1/2 x 3-3/4 x 3/4
II	Pullman Sides(2)	4-1/2 x 6-3/4 x 3/4
JJ	Observation Railings (2)	2 x 3-3/4 x 3/4

COLD FRAME-3



With the increasing popularity of gardening these days, more and more people are discovering the benefits of cold frames. Not only can you save money and extend your growing season by using them, you'll also be able to start your own plants from seedlings that will be directly acclimatized to your locality.

Just as the name implies, a Cold Frame is a FRAME with sides and a top, but no bottom. We built the one shown here from scratch using purchased glass panes. You can also use clear plastic material such as Lexan® or Plexiglas®...just be sure they're UV-resistant to prevent "clouding".

However, if you prefer, you can also build one from an old window or two that you might have laying around the house, or be able to find at a local flea market. The glass inserts from discarded storm doors also make excellent cold frames. If you decide to recycle some old windows, you will, of course, have to adjust your dimensions accordingly.

Start by choosing the lumber you plan to use. Since Cold Frames are intended for use outdoors, we suggest that you build your Frame from a weather resistant wood such as Western red cedar, pressure-treated lumber or cypress, depending on what's readily (and economically) available in your area. Redwood also makes an excellent choice for durability, although it's usually quite expensive.

Remember, you can make your frame any size you like to accommodate the plants you plan to protect. Just adjust your component sizes accordingly.

For our example, we started with wide 11" to 15" boards for the ends and sides of the frame. Doing so ensures that the windows rest about 10" above the surface of the ground. Another important point of consideration is the insulating properties of the wood you're using. If you're building with standard "2-by" lumber (about 1-1/2" thick), your frame will be self-



insulating. However, if you use 3/4" lumber, you'll need to mound-up the soil around the outside edge of the frame for added protection from the elements.

Start by cutting all of your pieces to size, as shown in the drawing. Cut the mitered 30-degree angles using your Table Saw & Miter Gauge. An angle setting gauge such as the MiterMatic Angle Setter can make quick work of achieving the exact 30-degree angle you need.

Use your Dado Set to create the rabbets for your glass or plastic panes, then drill all the necessary holes for the dowels that will help align and hold the frame together. Or, if you prefer, assemble your frame using biscuits.

Assemble your frame using a weather-resistant glue such as Titebond II® or a two-part epoxy such as Resorcinol. Once all of your components have set up properly, apply the stain or paint of your choice (or none, it's up to you).

Next, assemble the panes using glazing compound with glazing points or small brads as retainers. Attach the lift-up windows with hinges and add handles. NOTE: We recommend that you use brass hardware, since it won't rust.

A few words about using your Cold Frame:

- ❑ Place the Frame in the warmest spot in your yard.
- ❑ Sink the sides 2" to 4" into the ground and anchor the Frame into position with stakes at the inside corners.
- ❑ Once the plants are in, keep an "eagle-eye" on heat and moisture. The most common mistake is to allow small seedlings (or even full-sized plants) to "cook" inside the frame - or to not allow moisture build-ups to escape (which lets mold and fungus grow). Both of these conditions are easily remedied by simply raising the top slightly...but DON'T FORGET to close the top at night.



LIST OF MATERIALS

(finished dimensions in inches)

Ends (2)	11-1/4 x 34 x 3/4
Sides (2)	11-1/4 x 43-3/4 x 3/4
Window Frame Sides (4)	2 x 23-1/4 x 3/4
Window frame center (2)	5 x 11-3/4 x 3/4
Top (1)	6 x 35-1/2 x 3/4
Top lid frame rails (4)	2-1/4 x 35-1/2 x 3/4
Top lid frame stiles (4)	2-1/4 x 20 x 3/4
Dowels (optional) (20)	5/16 dia. x 3/4 long

HARDWARE

Lid glazing (2)	21 x 32 x 1/8
Side glazing (4)	10-1/2 x 17-3/4 x 1/8
Handle (2)	4-1/2 long (Brass)
Butt hinges (4)	2-1/2 x 1-3/4 (Brass)
Flathead wood screws (16)	1-1/2 x #10

Top Lid Frame

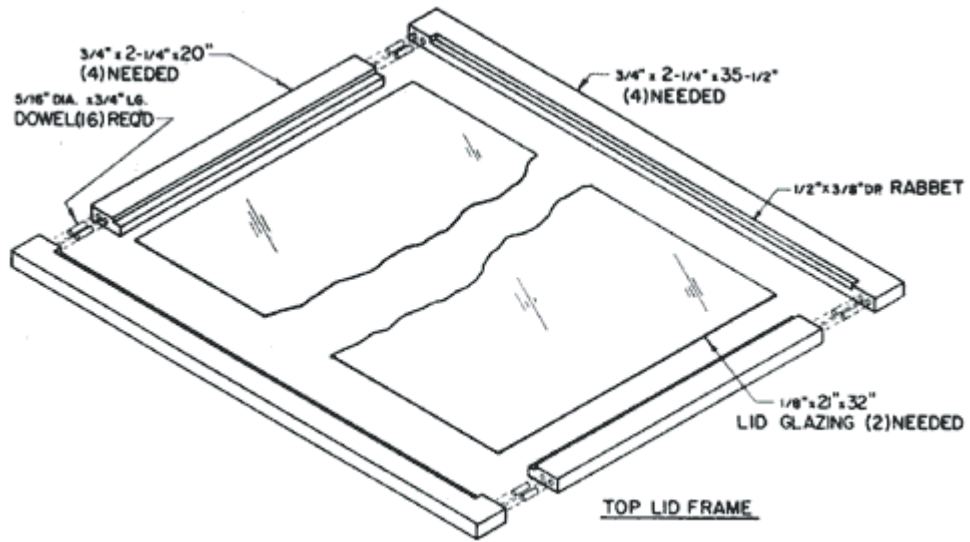

Base

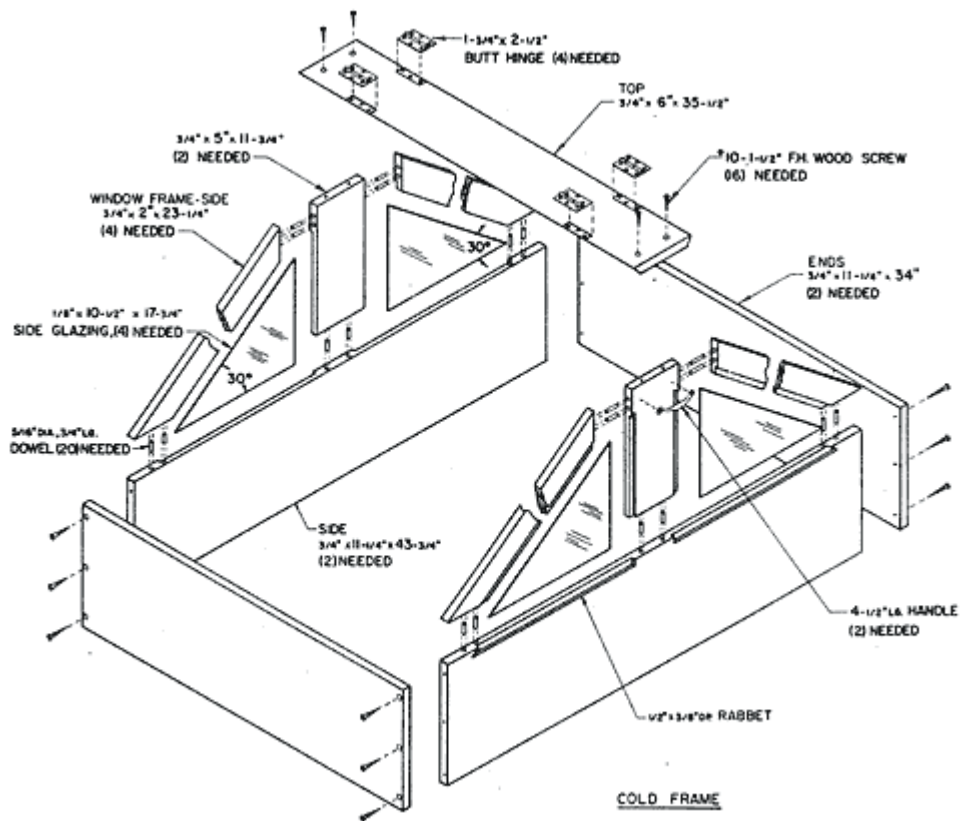

HOME TWEET HOME



Blue Jay House



Wren House

Getting the birds to flock to your home is a lot easier when you provide them with elegant, low- cost housing that appeals to their needs. Here are two houses you can build (by yourself or with the help of your teenagers) that will attract Wrens and Blue Jays to your yard. While you're at it, why not build some extras to give as gifts to your friends, family and neighbors? They're sure to be a big hit with everyone, "fine-feathered" and otherwise!

WREN HOUSE

Wrens are small songbirds that are noted for providing pleasant, sweet-sounding music. Because of their willingness to adapt to both rural and city life, they're also easy to attract.

Constructing this Wren House is simple and basic. In fact, you can make four of these attractive little houses from a single, 8-foot 1" x 6" piece of lumber. Here's how:

Step 1: Start by cutting two ends (A) from each two-foot long 1" x 6".

Step 2: Use your Bandsaw to resaw the remainder of each two-foot long board in half, then plane each board to a 5/16" thickness.

Step 3: Cut all parts (B, C, & D) to size as shown in the drawing.

Step 4: Tilt your saw table to 45-degrees and bevel the Roof (B), Sides (C) and Bottom (D) as shown in the drawings.

Step 5: Drill the entrance hole no larger than 1" in diameter to keep out all undesirable birds, then drill a 1/4" hole to accept the dowel perch.

Step 6: Use small galvanized or aluminum nails and waterproof wood glue to assemble the Ends, Roof and Sides. NOTE: When working with thin woods,



it's always a good idea to drill small pilot holes for all nails prior to assembly to prevent wood splitting.

Step 7: Using a 3/32" diameter drill bit, bore pilot holes for the screw eyes in the top of the Roof. Install the screw eyes.

Step 8: Tap the Perch (E) into place. It should fit snugly without glue, but if it doesn't, a little glue will help hold it in position.

Step 9: Slide the bottom into position. Do not glue or nail the bottom. This allows its easy removal for clean-out.

Step 10: Apply the finish of your choice (see the Tips For Bird Houses box). Once the finish has dried, hang the house from your favorite tree. Wren houses should be hung 6' to 10' above ground.

BLUE JAY HOUSE

Blue Jays are often loud, always protective of their turf and beautiful birds to have around. This house provides ample space for Blue Jays to raise a family and a convenient hinged top for clean-out once they've moved on. You can make two of these attractive little houses from a single, 6-foot 1" x 6" piece of lumber. Here's how:

Step 1: Start by cutting a Front (A), Back (B), Bottom (C) and Roof (D) from each 3-foot long piece of 1" x 6" wood.

Step 2: Use your Bandsaw to resaw the remaining piece of stock in half to make the two Sides (E). Since this piece is too small to safely run through a thickness planer, use your Shoppersmith Belt Sander to bring these pieces to their 5/16" thickness and smooth their resawn surfaces.

Step 3: Cut the two sides (E) to their 8-5/8" length...then set your Miter Gauge to 70-degrees to form the angled top edges, as shown in the drawing.

Step 4: Return your Miter Gauge setting to 90-degrees, tilt your saw table to 20-degrees and bevel the tops of the Front (A), Back (B) and the ends of the Roof (D), as shown in the drawing.

Step 5: Drill a 1-1/2" entrance hole in the Front (A), then drill a 1/4" hole to accept the dowel perch (F) and another 1/4" diameter mounting hole in the Back (B).

Step 6: Use small galvanized or aluminum nails and waterproof wood glue to assemble the House. Since the Sides, Front and Back are nailed directly to



the 3/4" thick Back and Bottom, pilot nail holes will not be necessary with this House.

Step 7: Mount the Roof (D) to the Back (B) with 1" x 1" brass hinges.

Step 8: Tap the Perch (E) into place. It should fit snugly without glue, but if it doesn't, a little glue will help hold it in position.

Step 9: Apply the finish of your choice (see Tips For Bird Houses). Once the finish has dried, screw the House to your favorite tree. Blue Jay houses should be hung 5' to 10' above ground.

Tips for Bird Houses

Here are a few valuable tips of interest to Bird House builders:

Use woods that are suitable for outdoors. Redwood, cedar, cypress and exterior grade plywoods are all good choices. **DO NOT** use pressure treated woods as they may be harmful to wildlife.

Use only rust-resistant hardware made of galvanized steel, aluminum, brass or stainless steel for best results.

Build all Bird Houses so they can be cleaned out at least once a year to control lice. Hinged tops or sliding bottoms are just two construction techniques that allow for easy clean-out.

Finish Bird Houses with exterior grade stains or paints. When painting, choose light colors to minimize heat absorption on hot Summer days. Never place a Bird House where squirrels, cats or other bird enemies may pose a threat.

Keep Houses away from noisy human or automotive traffic areas.

Drill all entrance holes from the front side of panels until the bit tip barely comes through the wood. Then, stop drilling and drill the remainder from the back side to prevent splintering that could injure birds.

If your House will be placed where it is not protected from heavy rainfalls by eaves, etc., it's a good idea to drill a few 1/8" diameter drainage holes in the bottom.

Hatchlings often benefit from footholds inside the house. If your house has smooth sides, it may be difficult for them to reach the opening. These footholds can be provided by gluing small 1/4" square scraps of wood or dowels to the inside surfaces...or by using a saw blade or chisel to cut a series of horizontal grooves across surfaces to roughen them.



LIST OF MATERIALS

(finished dimensions in inches)

Wren House		
A	Ends(2)	3/4 x 4-1/2 x 4-1/2
B	Roof (2)	5/16 x 5-1/2 x 7
C	Sides (2)	5/16 x 3-1/2 x 5-1/2
D	Bottom	5/16 x 2 x 5-1/2
E	Perch	1/4 dia. x 1-1/2
3/8" Screw Eyes (2)		
Blue Jay House		
A	Front	3/4 x 4 x 7
B	Back	3/4 x 4 x 8-5/8
C	Bottom	3/4 x 4 x 3-1/2
D	Roof	3/4 x 5-1/2 x 6-1/4
E	Sides (2)	5/16 x 5 x 8-5/8
1" x 1" Brass Hinges (2)		

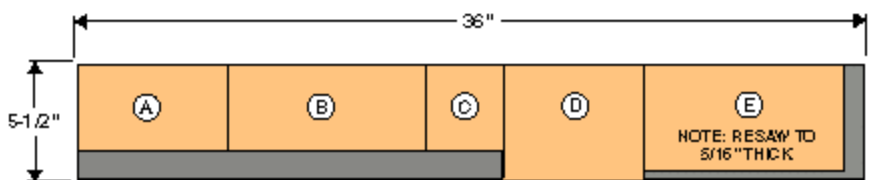
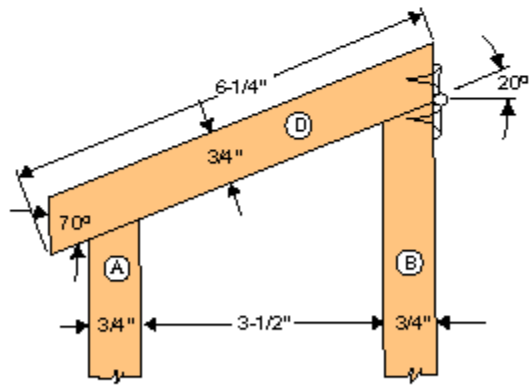
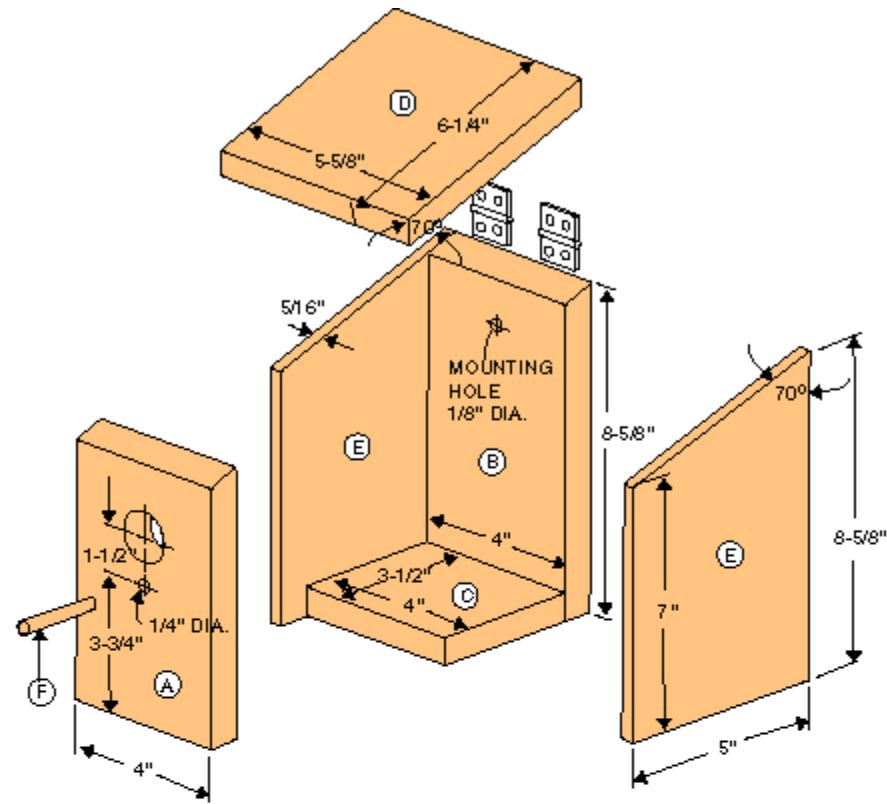

CUTTING DIAGRAM FOR BLUE JAY HOUSE

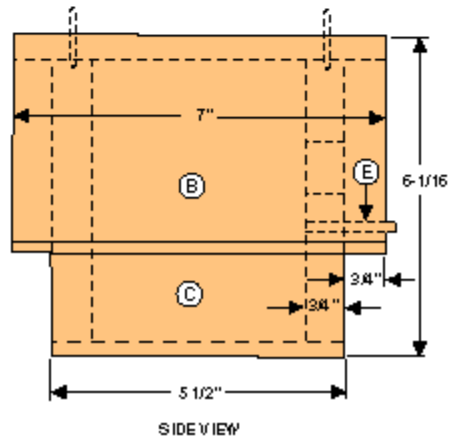
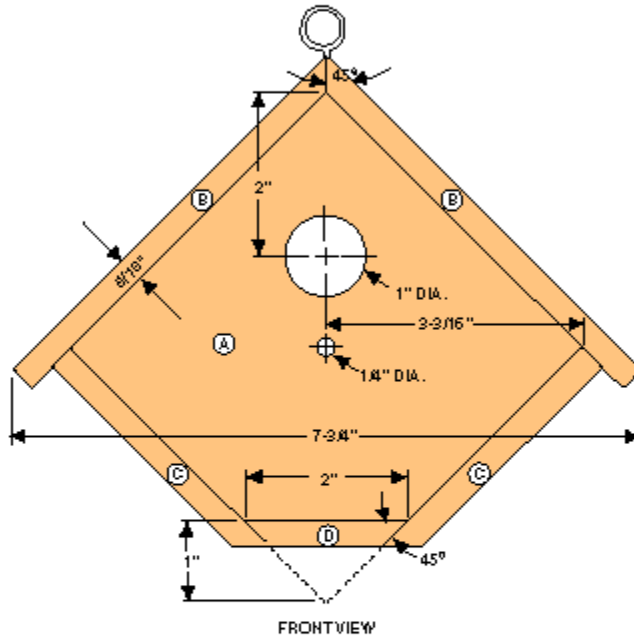
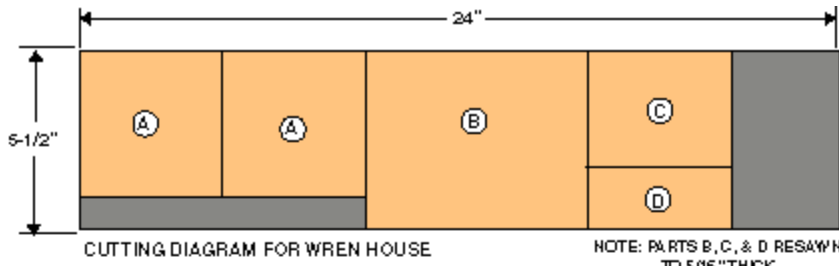

DROP LEAF TABLE-1



Our traditional drop leaf table is a versatile, compact piece of furniture, offering a multitude of uses in your home decorating plans. For example, placed in your entry hall under a mirror, it can be a warm welcome for your guests, or you can open both leaves and place it beside your couch to showcase a special lamp. You can even open one leaf and use the table as a bedside accent to support your reading lamp and telephone. Thanks to its versatility, the Drop Leaf table has as many possibilities as your imagination can conjure.

Several years ago, *Hands On* featured a Drop Leaf table, and the response was only lukewarm. Oddly, the feedback we received didn't mention the number and variety of joints required (as we expected), rather, it was about the extreme difficulty of turning all four legs to match. Our research shows that for years, do-it-yourselfers and leisure-time woodworkers have not attempted projects that involve making duplicate turnings on the lathe. After all, lathe turning - especially making pieces such as the legs in this project - demands a great deal of time to develop the required skills.

But now, the Lathe Duplicator has changed the rules. Now the tedious hours of marking, measuring, and practicing are over. With this duplicator, you simply make your pattern, mount it above the raw stock, and every piece you turn becomes an exact duplicate. It's virtually impossible to make a mistake.

Of course, you don't have to use a lathe duplicator to complete the Drop Leaf table project, but it's safer, easier, and far more precise than free-hand turning - and all your table legs will match perfectly.

This small Drop Leaf table is patterned after a traditional Pembroke Table. Mortise-and-tenon joinery is used in this project to make a table that's long-lasting and quite durable. Drop Leaf or rule joints are used to enhance the table's lines and eliminate the otherwise visible gap between leaves and tabletop.

1. Cut all the stock to size according to the List of Materials.
2. Since you will likely use several pieces of stock glued together for the tabletop (M), we suggest cutting the edges of that stock with a very sharp Glue Joint Shaper Cutter (Fig. 1). This gives you a self-aligning, unitized spline/groove combination, increases the gluing surface, and provides a stronger bond. The rough top to be squared later should measure 36" x 19", thus providing ample stock to cut the Drop Leaf joint. Hint: keeping the worktable at waist level makes controlling the workpiece easier.

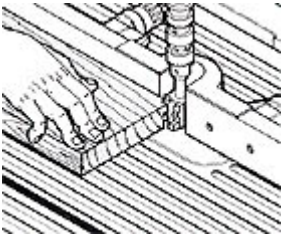

Fig. 1 Cutting glue edge.

3. To cut in the Drop Leaf joints (Fig. 2) before the edges of the table are shaped, use the Drop-Leaf joint shaper cutters, Drop Leaf Bead Cutter & Drop Leaf Cove Cutter, and slowly ease it into the stock - about 1/4" each pass. This two-knife set requires that one be raised from underneath and one be lowered onto the workpiece.

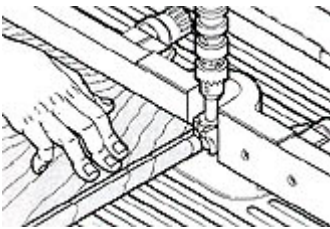

Fig. 2 Cut in the Drop Leaf joints before the edges of the top are shaped.

4. The slot mortise-and-tenon joints will give real strength to your table and minimize the wobble found in less structurally sound joints. Used here as one of the locking joints, it helps form the rugged and sturdy framework. To prevent mixing the faces as you cut the joinery, carefully mark and identify the table leg (A) stock relative to their final positions. Mark locations for eight slot mortises and two dovetails (See Table Assembly)
Turn the legs (A) on the lathe. Next, remove most of the stock from the mortises with the Slot Mortising Package. Then, use any combination you

prefer of to square-up the mortises. (Always cut the slot mortises before the tenons, as it is easier to adjust a miscue in the mortise than tenon.)

5. Cut the dovetail slots in the top of the front legs (See Table Assembly). The locking dovetails anchor the entire front of the table assembly and lock the legs and front (H) firmly together.

Mark the top of the legs with a sharp knife. For initial roughing out, use a 1/2" brad point bit with the Mark V set in the horizontal-boring mode. Finish with a 1/2" chisel. Use a Bandsaw to cut the male dovetail on the front top rail (C). Finish fit with a chisel and wood rasp.

Next, use the Dado set and an extension fence (Fig. 3) to cut the eight tenons and custom-fit your slot mortises. Use a sharp knife to mark tenons (this prevents splinters as you make Dado cuts). To leave room for glue to expand, cut tenons 1/8" less in length than the depth of the corresponding mortises.

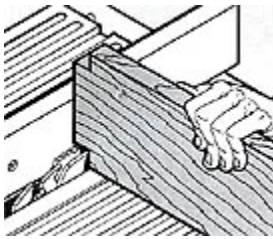

Fig. 3 Using Dado to cut tenons (note use of extension fence).

6. To make dowel joints on the Drop Leaf supports (F), use a Dado blade with the miter gauge set at 45° to cut the opening in the sides (Fig. 4). A 45° miter on each end makes these supports self-aligning, flush to the side when closed. Next, cut the supports and drill for the dowel pins. Rub a little soap on the dowels and insert them in the supports and sides.



Fig. 4 Cutting the opening for Drop Leaf supports – 1/2 of the depth at a time.

If you'd like to add a decorative touch around the base of the apron (B & E), use a Bead & 1/4 Round molding cutter positioned half-way onto the surface of the bottom edge of the stock. For safety, use a push stick or push block.

Next, drill 3/8" screw pockets (Fig. 5) in sides (B) and back (E) to hold the top in place. (The table base and top form a simple butt joint and need this reinforcement.)

Dry assemble the legs (A) to the apron pieces (B, C, D & E) to check the fit and apply masking tape at each joint. Disassemble and carefully apply glue to each slot mortise-and-tenon and dovetail. Reassemble, check squareness, and clamp together for 24 hours. The tape keeps excess glue from seeping onto the face of the wood.



Fig. 5 Drilling screw pockets in sides. Drilled at 10° with a 1/2" brad point bit, to within 3/8" of the bottom. Use a 1/4" brad-point bit to make pilot hole for the #12 roundhead screws.

7. To withstand the pressure exerted on the drawer case, we used a combination Dado/spline joint to lock the front of the drawer front (H), (See Detail B).

Turn the drawer front on edge and use a Dado blade to cut the 5/16" x 3/4" deep Dado, then use a regular blade to cut the 3/16" x 1/4" deep spline. Next, cut the 1/2" stop Dado for the drawer end with either a Dado blade or Router Package (Fig. 6). The strength of these joints eliminates the need for glue-blocks.

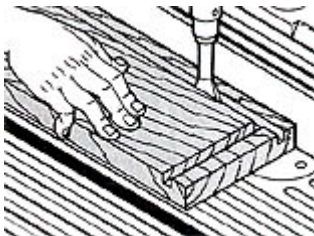

Fig. 6 Routing 1/4" groove for drawer bottom.

8. To cut the self-aligning sliding dovetails in drawer sides (J), use the Mark V in the drill press mode with a dovetail router bit (Fig. 7). Next, with the Mark V still in the drill press mode, rout the drawer guides (G), (Fig. 8).

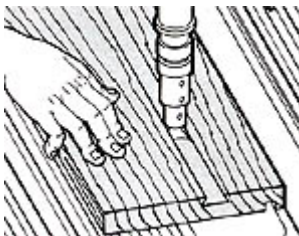

Fig. 7 Routing dovetail slot for drawer guide. Two passes are needed; both at full 1/4" depth.

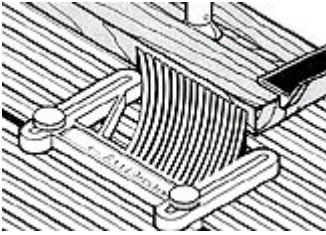

Fig. 8 Routing dovetail drawer guides with feather board firmly holding stock against fence. Push against router rotation.

Drill and countersink holes for attaching the guides to the inside of the aprons on the sides' (B). Assemble and glue the drawer (but not the bottom [L], as final fitting may be necessary). Mark for the drawer guides (G) and drill pilot holes - but don't attach them yet.

The position of the Drop Leaf hinges is critical (See Detail A). From the shoulder of the joint, move the hinges 1/16" toward the leaf. This prevents binding as the leaf moves. As you make the shallow mortise to accept the hinge, form a relief cut for the hinge's cylinder or pivot.

9. To withstand the pressure exerted on the drawer case, we used a combination Dado/spline joint to lock the front of the drawer front (H), (See Detail B).

Turn the drawer front on edge and use a Dado blade to cut the 5/16" x 3/4" deep Dado, then use a regular blade to cut the 3/16" x 1/4" deep spline. Next, cut the 1/2" stop Dado for the drawer end with either a Dado blade or Router Package (Fig. 6). The strength of these joints eliminates the need for glue-blocks.

Next, fit the top into place - no glue, screws will hold it and permit expansion/contraction. Once the top is secured, mount the drawer guides - no glue. Rub with soap for smoothness.

Finally, remove the Drop Leaf hinges. Finish sand and apply stain and finish. Now that you're finished, give yourself a hearty pat on the back and show your new custom-crafted, Drop Leaf table to someone you care about. Congratulations! Now is when the satisfaction and reward really begin.



Hardware Hinges - the Drop Leaf hinge increases the beauty of the piece by eliminating the unsightly gap formed by butt hinges. Plus it adds a touch of professionalism. When installing the hinge, fasten the small side to the Drop Leaf and the large side to the table underside. Be sure to specify 1-1/4" when buying your hinges.



LIST OF MATERIALS

Finished dimensions in inches.

Hardwood:

Piece	Description	Size
A	Legs (4)	1/4 x 1-1/4 x 25
B	Sides (2)	3/4 x 6 x 14-1/2
C	Front Top Rail	3/4 x 1-1/4 x 16-1/2
D	Front Bottom Rail	3/4 x 1-1/4 x 16-1/2
E	Back	3/4 x 6 x 16-1/2
F	Drop Leaf Supports (2)	3/4 x 3/4 x 10
G	Drawer Guides(2)	3/4 x 1-1/16 x 13
H	Drawer Front	3/4 x 4-1/2 x 15
J	Drawer Sides (2)	3/4 x 4-1/2 x 15-1/4
K	Drawer Back	1/2 x 3 3/8 x 14
L	Drawer Bottom	1/4 x 14 x 15-1/4
M	Tabletop	(before joinery) 3/4 x 36 x 19
N	Dowels (2)	3/8 dia. x 1-1/2

Hardware:

Qty	Description
4	#12 x 1-1/4" Flathead wood screws
5	#12 x 1" Roundhead wood screws
6	1-1/4" Table hinges

Front Layout View

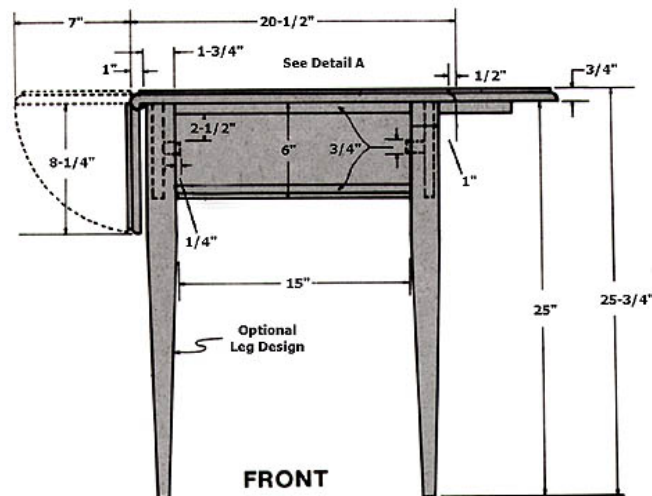

Side Layout View

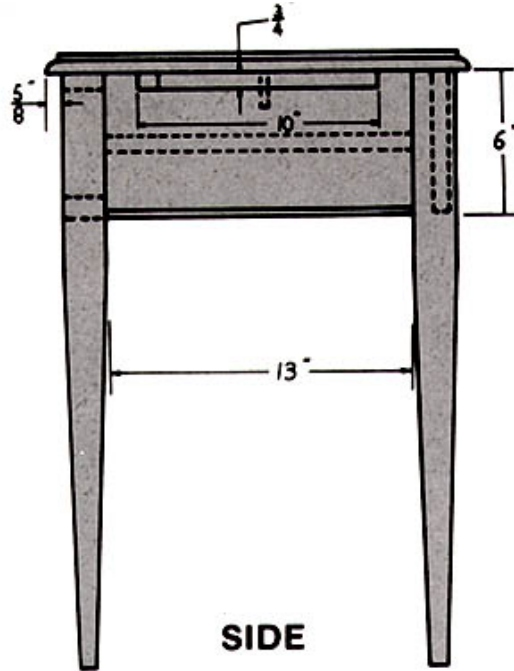

Turned Leg Layout

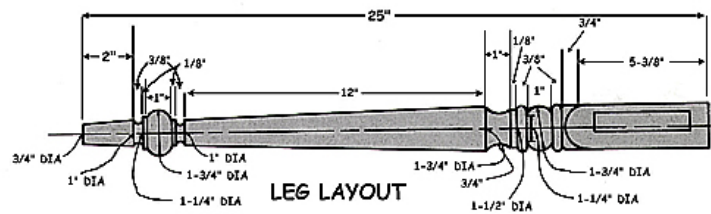

Front Leg Assembly #2

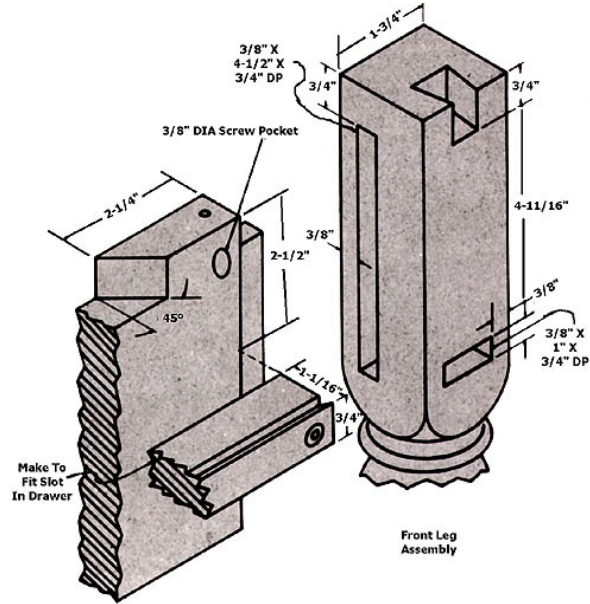

Detail A

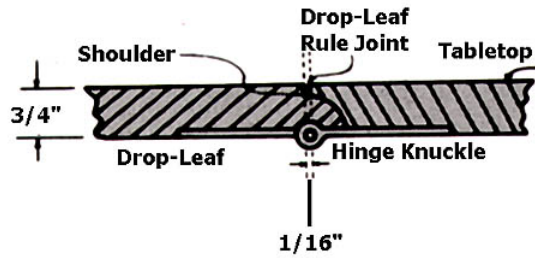

Detail B

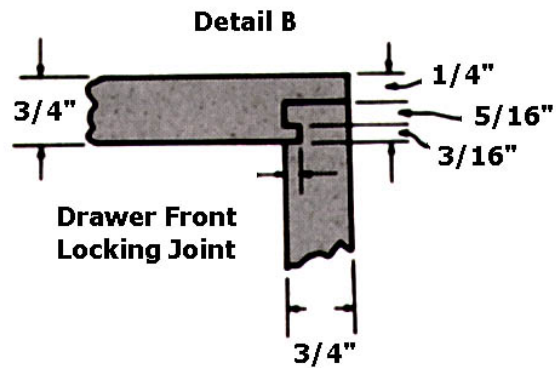
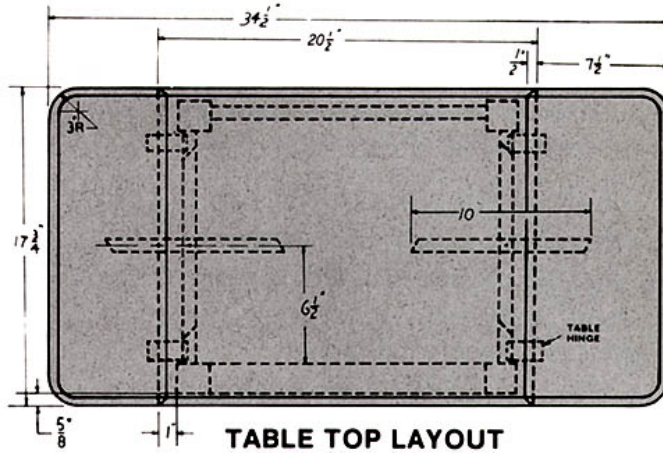

Table Top Layout



Front Leg Assembly #1

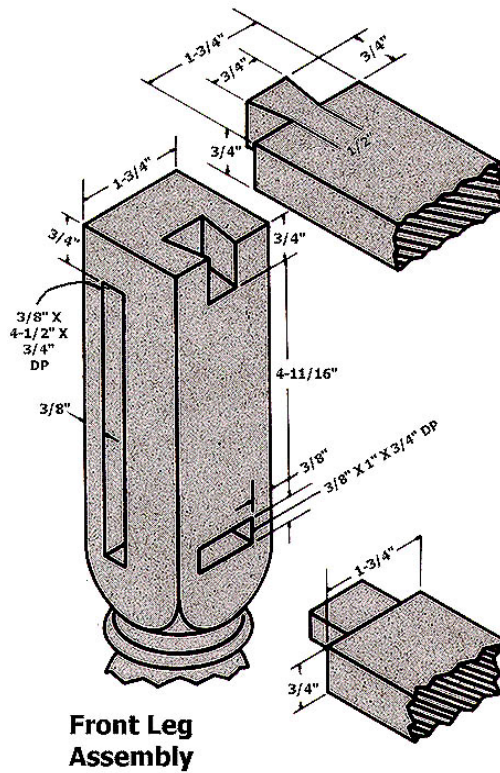
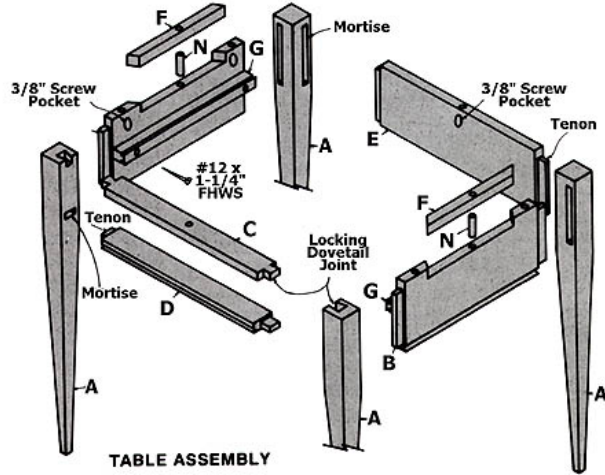
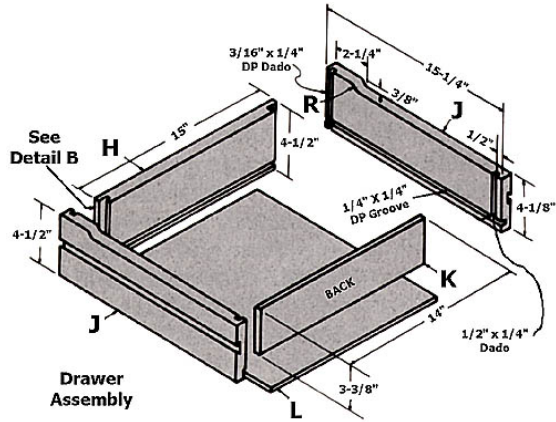

Table Assembly



Drawer Assembly



Draw Slide

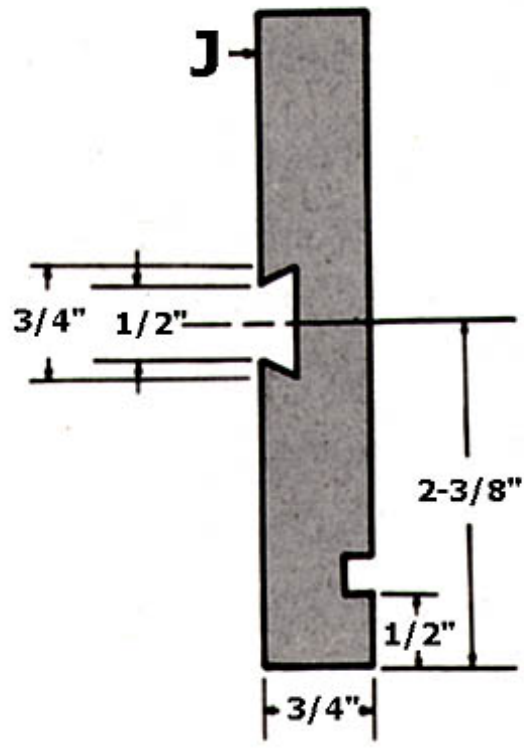

PEMBROKE TABLE



This small drop-leaf table with drawer is modeled after a traditional Pembroke Table. It is a versatile, compact piece of furniture, offering a multitude of uses in your home decorating plans. Place it in an entry hall under a mirror to offer a warm welcome to visiting guests. Open both leaves and place it next to a sofa to showcase a special lamp or other prized object. Open a single leaf and place it next to your bed for the telephone and a reading lamp. The drop leaves bring untold versatility to this handsome little table.

The table uses a total of eight different joints; five of them functioning as "locking joints" that help hold the carcass or drawer together, the other three are part of the movable features of the table. Each joint was chosen for a good reason. But don't let all of this joinery overwhelm you. Remember, you don't have to cut all of them at once. Instead, you can parcel out the work to suit your own pace.

HERE WE GO

Start by studying the plan drawings. They contain all the information you need to build this great little table. Everything in these plans is there to help you - the smallest mark, the least dimension - review them all very carefully. Remember that an old, "Master Woodworker" once offered this formula: Of



the total time required to build this or any project, 60% should be invested in studying and planning your approach...10% in sharpening and setting-up your tools...10% in making your cuts and fitting everything together...and the last 20% in final sanding and applying your finish.

Only one kind of specialized hardware is required for the table...the drop-leaf hinges. We used two pairs of Stanley 1-1/4" table hinges (Stanley item # 46-330), which we ordered through a woodworking supply catalog. All other hardware came from a local Home Center.

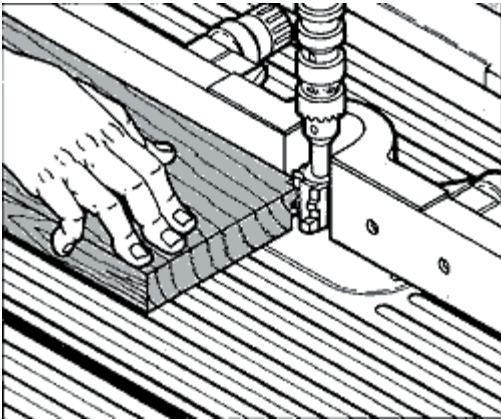

Figure 1. Cutting glue edge.

1. Create the glue joints that will hold the pieces of the top together. We used the Shopsmith Glue Joint Shaper Cutter to make the cuts for this joint. We recommend this joint because it consists of a unitized, self-aligning spline/groove combination that dramatically increases the amount of gluing surface. As a result, you get an incredibly strong joint, once assembled.

When shaping these joints, remember to set your MARK V Work Table at waist-height or a little lower for optimum workpiece control and be sure your Shaper Cutters are sharp before you get started.

Your rough top, once assembled should be 36" x 19". This will give you plenty of stock to dress up the edges and cut the special drop-leaf joint.

Alternative Procedure: As an alternative, you could also use the Shopsmith Molder Set-Up with the Molding Glue Joint Cutter to create these joints.

2. Cut the drop-leaf (rule) joints that allow the leaves to be raised or lowered without leaving an unsightly gap between the leaves and the tabletop when the leaves are down. This movable joint is created by using the Shopsmith Shaper set-up and a combination of two cutters: The Drop Leaf Cove Cutter and the Drop Leaf Bead Cutter. When creating these profiles, it's best to make a series of light passes under the cutters for the smoothest, most

tight-fitting results. Again, sharp cutters can make a significant difference in your results.

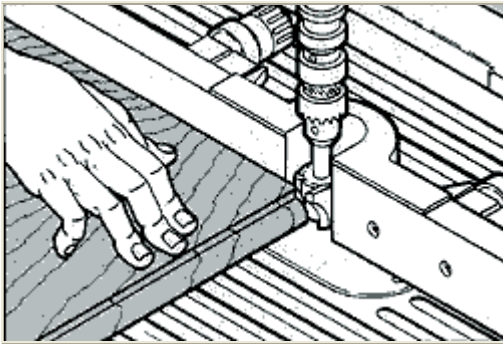

Figure 2. Cut in the drop-leaf joints before the edges of the top are shaped.

Alternative Procedure: As an alternative, you could also use the Shopsmith Molder Set-Up with the Molding Drop Leaf Cove and Bead cutters to create these joints.

3. Form the mortise-and-tenon joints that will anchor the table sides and back to the legs. These joints will stand up under stress from almost all directions. Used as one of our locking joints, they'll help form the durable carcass framework for our table. Start by carefully marking the stock used for the legs, identifying them relative to their final position on the table. This procedure will prevent mixing up the faces as you cut the joinery. Mark the locations for eight mortises and two dovetails.

Before you cut the mortises, however, turn the legs on the lathe. Use the Shopsmith Lathe Duplicator to help ensure that all four legs are identical.

Always cut the mortises BEFORE you cut the tenons because it's easier to cut (or adjust) a tenon to fit a mortise than it is to cut a mortise to fit an existing tenon.

Use your Shopsmith Mortising Package with a 3/8" Mortising Bit/Chisel Set to create these mortises. Be sure to use your Telescoping Legs or a cut-to-length 2"x4" to brace the MARK V worktable during this operation, as the process of cutting mortises with this set-up requires substantial downward pressure, which will create table flex. If you don't have a Mortising Package, you can also cut these mortises by removing most of the stock with a 3/8" brad point drill bit, then cleaning them out with a chisel...or by using your Router set-up with a 3/8" straight router bit.

Next, mark the tenons with a knife to prevent feather splinters, then use your Dado Set-Up to cut the tenons, custom-fitting them to fit your mortises. Cut them 1/8" shorter than the depth of your mortises to leave room for the glue.

A Rule of thumb for mortise-and-tenon joints: Mortise widths should be no more than one-third to one-half the thickness of the stock you're using.

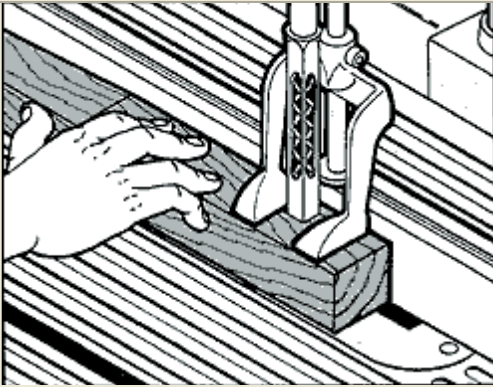

Figure 3. Cutting mortise in leg (note hold-down).

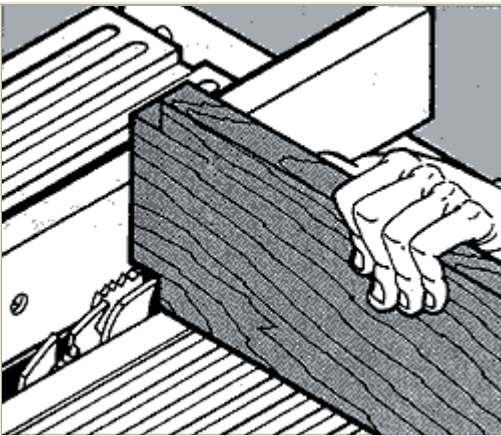

Figure 4. Using dado to cut tenons (note use of extension fence).

4. Cut the locking dovetails. The "female" parts of these joints will be cut on the inside top of the two front legs...and the "male" parts will be cut on each end of the Front Top Rail (C). These joints will be located where the table will be stressed the most - at the top of the drawer opening - and will lock the legs and the front of the table assembly firmly together.

Start by cutting the dovetail slots in the tops of the two front legs. Use your horizontal boring set-up to drill out most of the waste, then clean them up with a 1/2" chisel.

Next, cut the mating dovetails into the ends of the Front Top Rail using your Bandsaw, then a chisel and wood rasp to achieve a tight, final fit with the Legs. It's best to cut these a bit over-size to begin with, then "pare" them down carefully until they fit snugly.

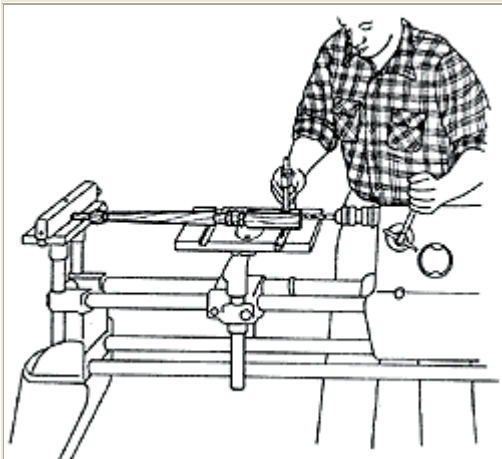

Figure 4.5. Forming dovetail socket in top of front leg. Horizontal bore removes about 80% of all waste stock.

5. Cut the doweled joint for the drop leaf supports. The supports (F) fit into hollowed-out areas at the tops of the two sides, and pivot on a center dowel. The ends of the hollows - and the ends of the supports are each mitered at 45-degrees. When closed, these mitered ends allow the supports to rest flush with the sides. NOTE: Refer to the drawings to be sure your miters go in the proper directions so the supports will pivot properly when installed.

You'll want some clearance for the dowel pins to move freely when this movable joint opens and closes. Cut the hollows (or openings) in the sides using a Dado Blade with your miter gauge set at 45-degrees. Next, cut the supports and drill them to accept the dowel pivot pins. Place the dowels in the supports and sides; rub a little paraffin onto them so they'll pivot smoothly. Do NOT glue them into place.

Use your Molding Set-Up with a Bead & Quarter-Round cutter to add a decorative bead around the two sides (B) and back (E) that form the base of the assembled table apron. Position it halfway onto the surface of the bottom

edge of the wood. Use your Push Stick or Push Block for added safety during this operation.

Next, drill screw pockets into the inside top edges of the sides (B) and back (E) to accept the screws that will hold the top of the table in place. Now, assemble the legs to the apron pieces to check the fit. Use no glue at this point. Instead, while everything's "dry-fitted" together, apply masking tape at each joint; take it apart and apply glue to each mortise and tenon - and each dovetail. Then - checking for squareness - clamp it together overnight. The masking tape will keep excess glue from seeping into the face of the wood.

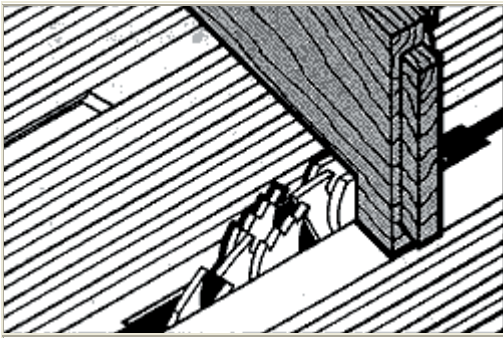

Figure 5. Cutting the opening for drop-leaf supports 1/2 of the depth at a time.

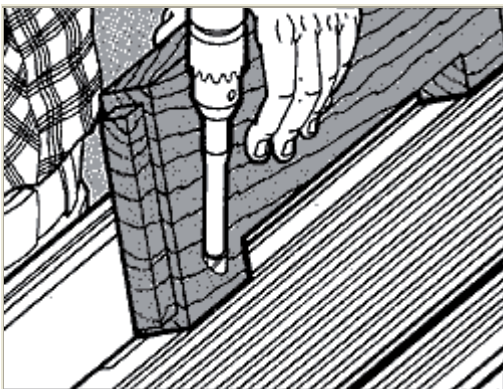

Figure 6. Drilling screw pockets in sides. Drilled at 10° with a 1/2" Forsner bit, to within 3/8" of the bottom. Use a 1/4" brad-point bit to make pilot hole for the #12 roundhead screws.

6/7. Form the locking drawer joints. The front of the drawer assembly is locked together with one of these fancy joints - a combination dado/spline.



This special joint is able to withstand the pressure exerted on the drawer case during loading, opening & closing. Using your Dado Blade, turn the drawer front on edge and cut the 5/16" wide by 3/4" deep dado first. Then cut the 3/16" wide by 1/4" deep feather spline with a regular saw blade.

Next, cut the 1/2" stop dado for the drawer end with the dado blade or a router and rout the groove for the drawer bottom. These joints will be strong enough to make added glue blocks unnecessary.

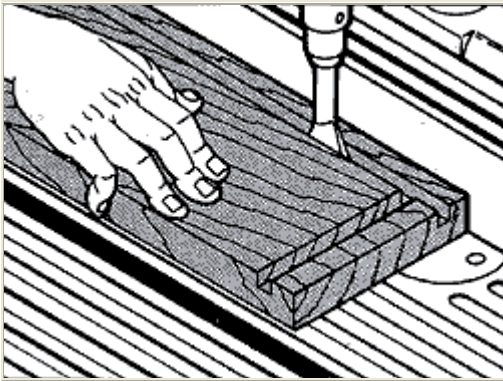

Figure 7. Routing 1/4" groove for drawer bottom.

8. Create the sliding dovetails. These movable joints are self-aligning - unlike square or center-mounted guides that can (and WILL) bind as you pull the drawer open. In the MARK V drill press mode, use the Shopsmith 1/2" Dovetail Router Bit to cut the (female) dovetail slot in the sides of the drawer. Using the same router bit and same basic set-up, cut the (male) drawer guides (G) to match the slots in the drawer sides. Use a push stick to feed the wood against the rotation of the bit. Now, drill and countersink the screw holes for attaching these guides to the inside faces of the two apron sides (B)...but don't attach them yet.

Assemble and glue the drawer together. Don't glue the bottom. You may need to do some final fitting. Mark the sides for the drawer guides and drill the screw pilot hole. Again, don't attach the guides yet.

Note that the position of the drop-leaf hinges is important (See Detail A). From the shoulder of the joint, move the hinges 1/16" toward the leaf. This will prevent binding as the leaf moves. As you chisel or rout the mortise to accept the hinge, form a relief cut for the barrel of the hinge.

Now, fit the top into place (use no glue - screws along will hold it, allowing it to move as the wood expands and contracts). Once the top is secured, mount the drawer guides without glue. Rub a little paraffin or wax on them for smooth operation.

Remove the drop-leaf hinges, final sand the entire project, stain and finish it as you like.

Believe it or not, woodworking is much less precise and demanding than let's say, machining steel. Therein lies both the pleasure and the frustration of it; wood remains organic, even after it's air or kiln-dried. Though it's a forgiving medium in which to work, you'll find that it can be stubborn, too. Tenons may balk at fitting into their mortises and dovetail pins may argue with their slots before they finally slip into place. But don't let inexperience or embarrassment at not knowing everything about wood keep you from the simple pleasures of making this enduring contribution to the world of fine furniture.

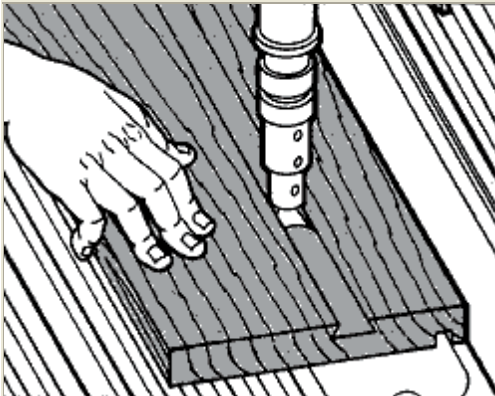

Figure 8. Routing dovetail slot for drawer guide. Two passes are needed, both at full 1/4" depth.

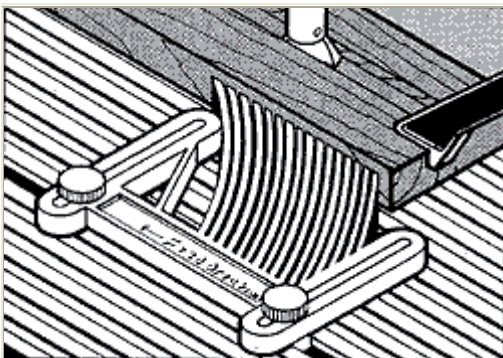

Figure 9. Routing dovetail drawer guides with feather board firmly holding stock against fence. Push against router rotation.



LIST OF MATERIALS

(finished dimensions in inches)

The Table		
A	Legs (4)	1-3/4 x 1-3/4 x 25
B	Sides (2)	3/4 x 6 x 14-1/2
C	Front Top Rail	3/4 x 1-3/4 x 16-1/2
D	Front Bottom Rail	3/4 x 1-3/4 x 16-1/2
E	Back	3/4 x 6 x 16-1/2
F	Drop-Leaf Supports (2)	3/4 x 3/4 x 10
G	Drawer Guides (2)	3/4 x 1-1/16 x 13
H	Drawer Front	3/4 x 4-1/2 x 15
J	Drawer Sides (2)	3/4 x 4-1/2 x 15-1/4
K	Drawer Back	1/2 x 3-3/8 x 14
L	Drawer Bottom	1/4 x 14 x 15-1/4
M	Table Top (before joinery)	3/4 x 36 x 19
N	Dowels (2)	3/8 dia. x 1-1/2

Hardware	
4	#12 x 1-1/4" Flathead Wood Screws
6	1" Roundhead Wood Screws
4	1-1/4" Table Hinges (2 pair, Stanley #46-3300)

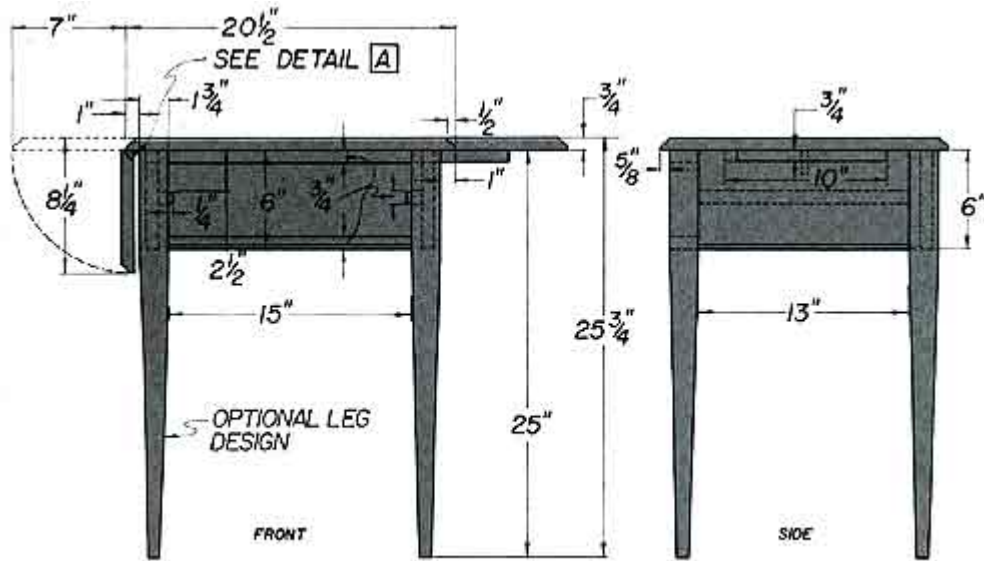

TABLE LAYOUT

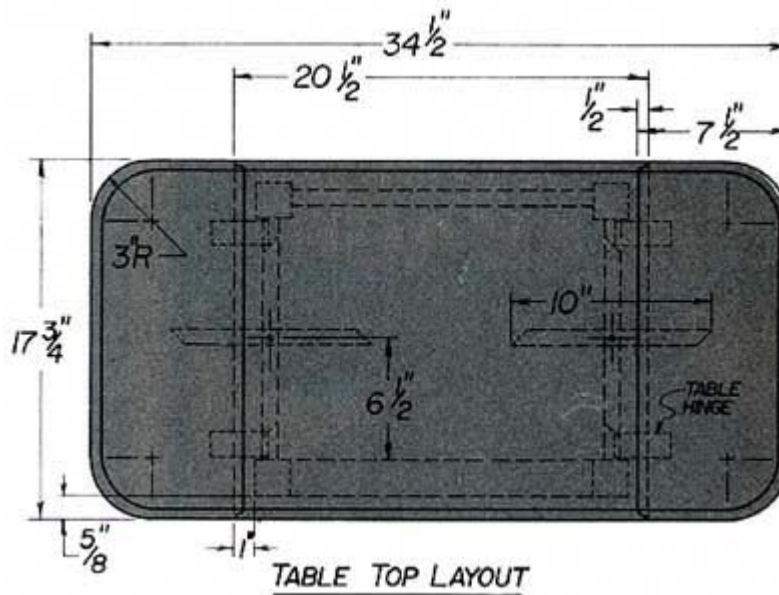
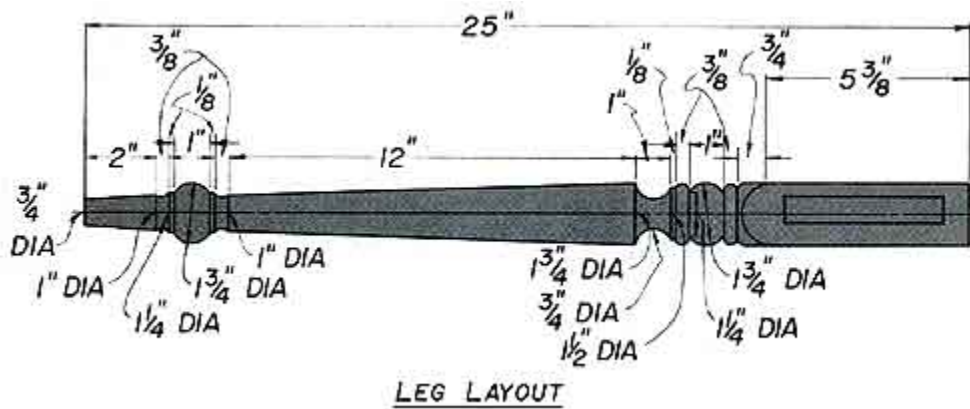
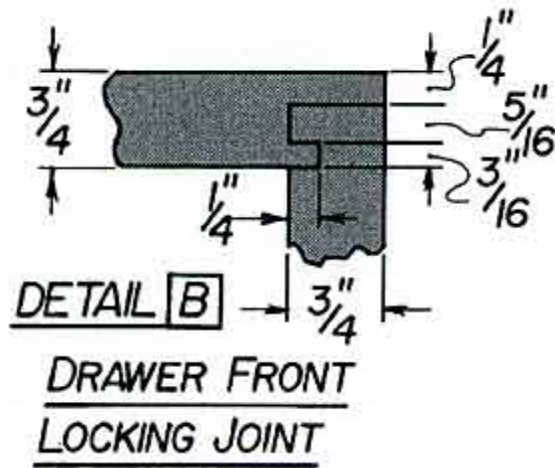
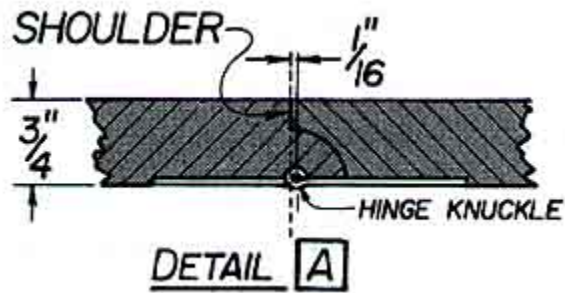
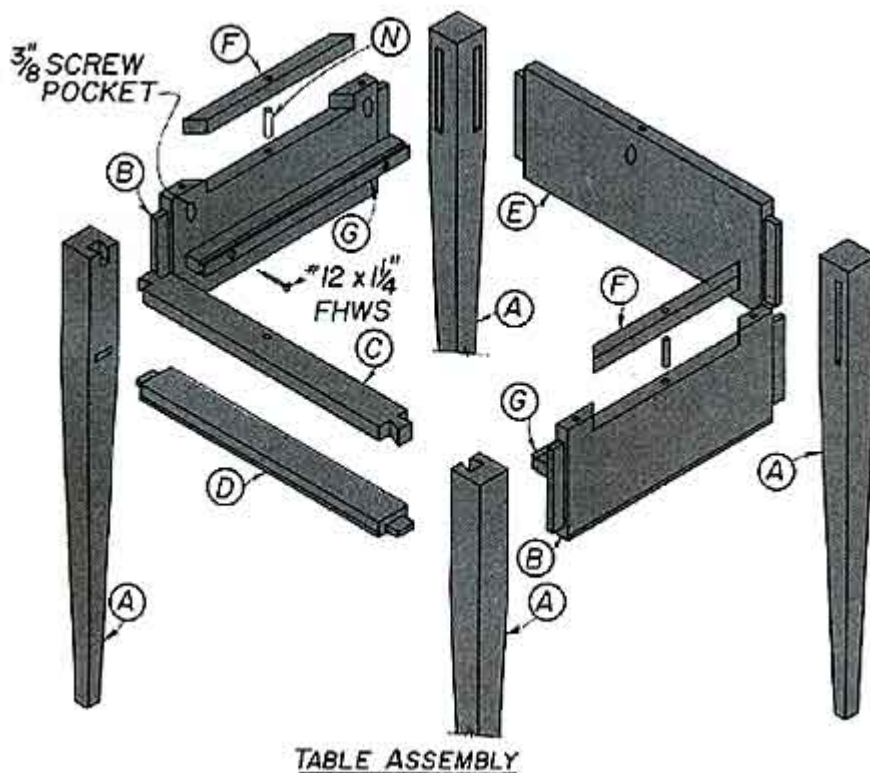
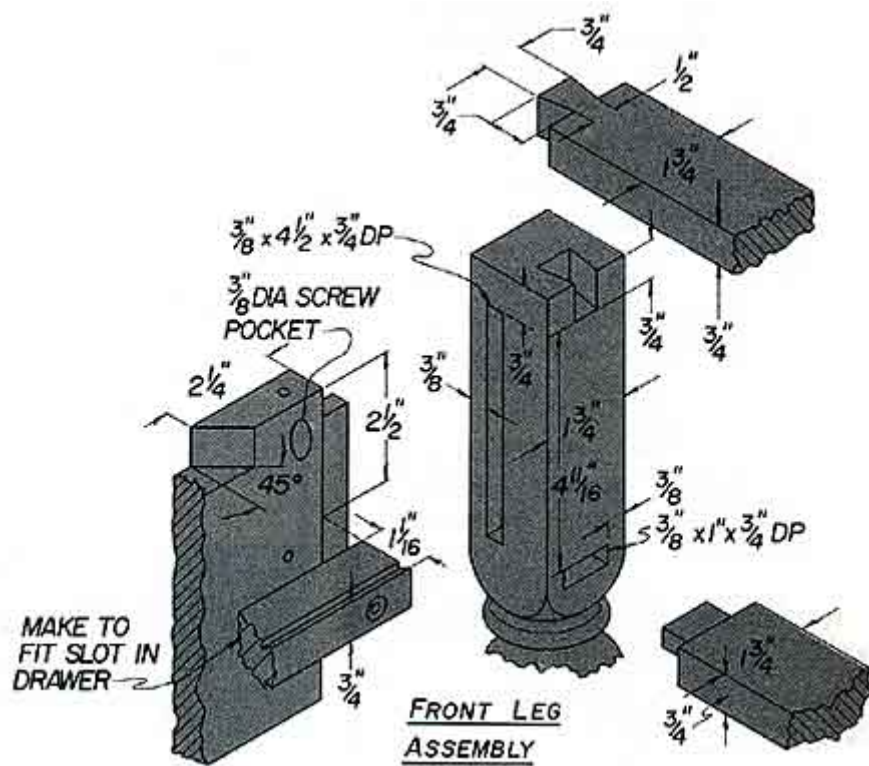
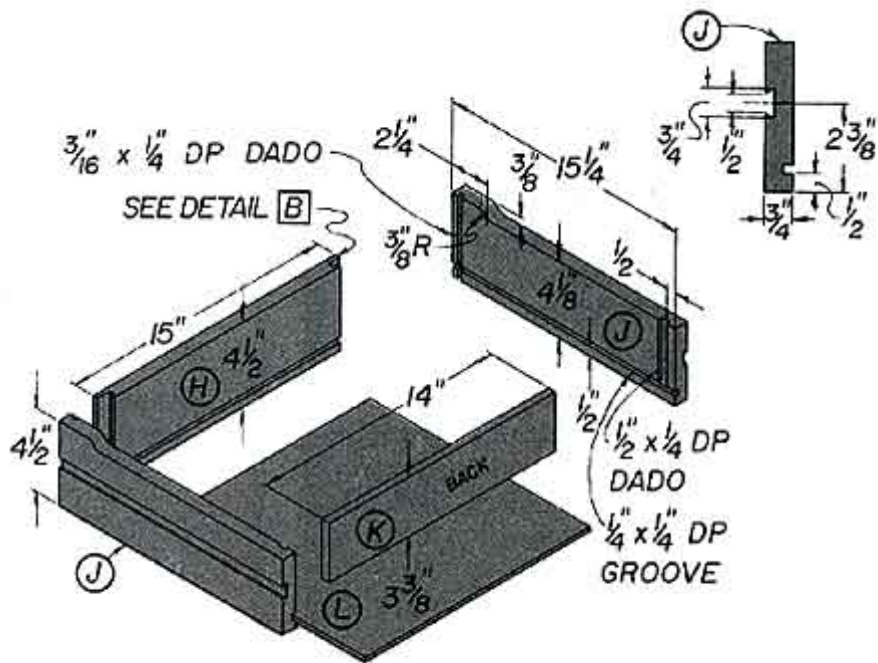

TABLE TOP LAYOUT







DRAWER ASSEMBLY

CHEVAL MIRROR



This elegant, generous-sized Cheval Mirror swivels on two turned pins to adjust for the perfect, full-length view, no matter where the viewer stands or how tall he or she may be.

Start the project by gluing up the stock for the side spindles. Be sure these pieces can be cut to a full 2" x 2" x 34" long. Before turning, use your drill press to drill dowel holes in the spindle stock for attaching the legs and stretcher, along with the pivot pin holes.

Use a Taper Guide to taper the spindle stock on all four sides 1/4" over a length of 26" from the top end (See Fig. 1), before turning them on the lathe. Next, sand the turned spindles smooth and apply masking tape to the areas where the legs and stretcher will be glued to them and apply your finish to them before you remove them from the lathe, then turn the pivot pins in the same manner to the exact dimensions given in the drawings.

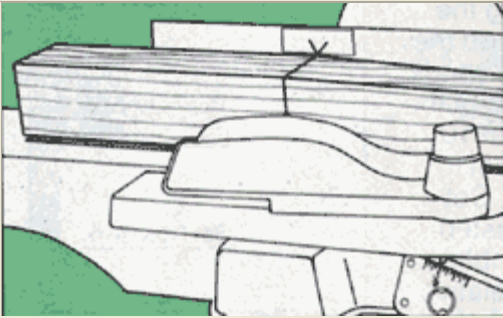

Figure 1. Tapering the spindle stock before turning. Leave bottom 8" square.

Now, cut the stock for the mirror frame, stretcher and legs to size on the table saw. Use your Dado set-up to cut the 3/8" deep by 3/8" wide rabbet in the back of the frame stock.

Use your Bandsaw and your Drum Sander to carefully shape the legs. Switch your MARK V to Horizontal Boring mode and drill the dowel holes in the legs and the stretcher (See Fig. 2).

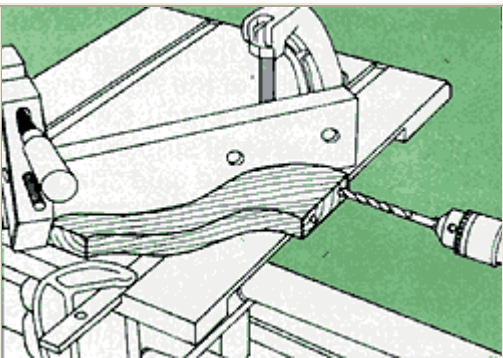

Figure 2. Boring dowel holes in legs. Note handscrew and C-clamp.

For best results, miter the ends of the stiles and ails of the mirror frame with a carbide-tipped combination or hollow ground saw blade...then cut the 1/2" deep spline kerfs on the ends of each piece and make the splines (See Power Tool Woodworking, Page 48). Use your Bandsaw to cut the contour on the top rail, then dry assemble the frame and base assembly. Mark the location of 5/8" pivot pin holes in the sides and drill them.

Round the top edges of the legs and stretcher with your Shaper set-up and a 1/4" quarter-round shaper cutter. As an alternative, you could also use the Shopsmith Routing Package with a 1/4" Round Over Bit. If you'd like a more



decorative edge on your mirror frame, use an Ogee Shaper Cutter or Router Bit...being careful to stop, then re-start your cut around the pivot pin holes to avoid cutting into them.

Next, glue and clamp the base assembly and the frame assembly together. Once they've dried, apply the finish of your choice. Install the mirror in the frame and back it with 1/8" hardboard. Mount the mirror frame to the base with the pivot pins and 3/8" I.D. O-Rings (faucet repair parts, available wherever plumbing supplies are sold). These O-Rings will supply the friction to keep the mirror positioned where you want it when tilted.

Fasten the pins to the frame with 3/4" flathead wood screws, secured from the back through the pivot pins.

LIST OF MATERIALS

(finished dimensions in inches)

The Pieces		
A	Spindles (2)	2 x 2 x 34
B	Stretcher	3/4 x 2-1/2 x 16
C	Legs (4)	3/4 x 3-1/2 x 10-1/2
D	Pivot Pins (2)	1 dia. x 3-5/8
E	Stiles (2)	3/4 x 2-1/8 x 51-3/8
F	Bottom Rail	3/4 x 2-1/8 x 15-1/2
G	Top Rail	3/4 x 4-1/4 x 15-1/2
H	Dowel Pins (12)	5/16 dia. x 2
J	Spindles (4)	1/8 x 1 x 3-1/2
K	Mirror Back	1/8 x 12 x 48

HARDWARE

(1)	1/8" x 12" x 48" mirror
(8)	Mirror Retainer Clips
(4)	3/8" I.D. O-Rings
(2)	#8 x 3/4" Flathead Wood Screws

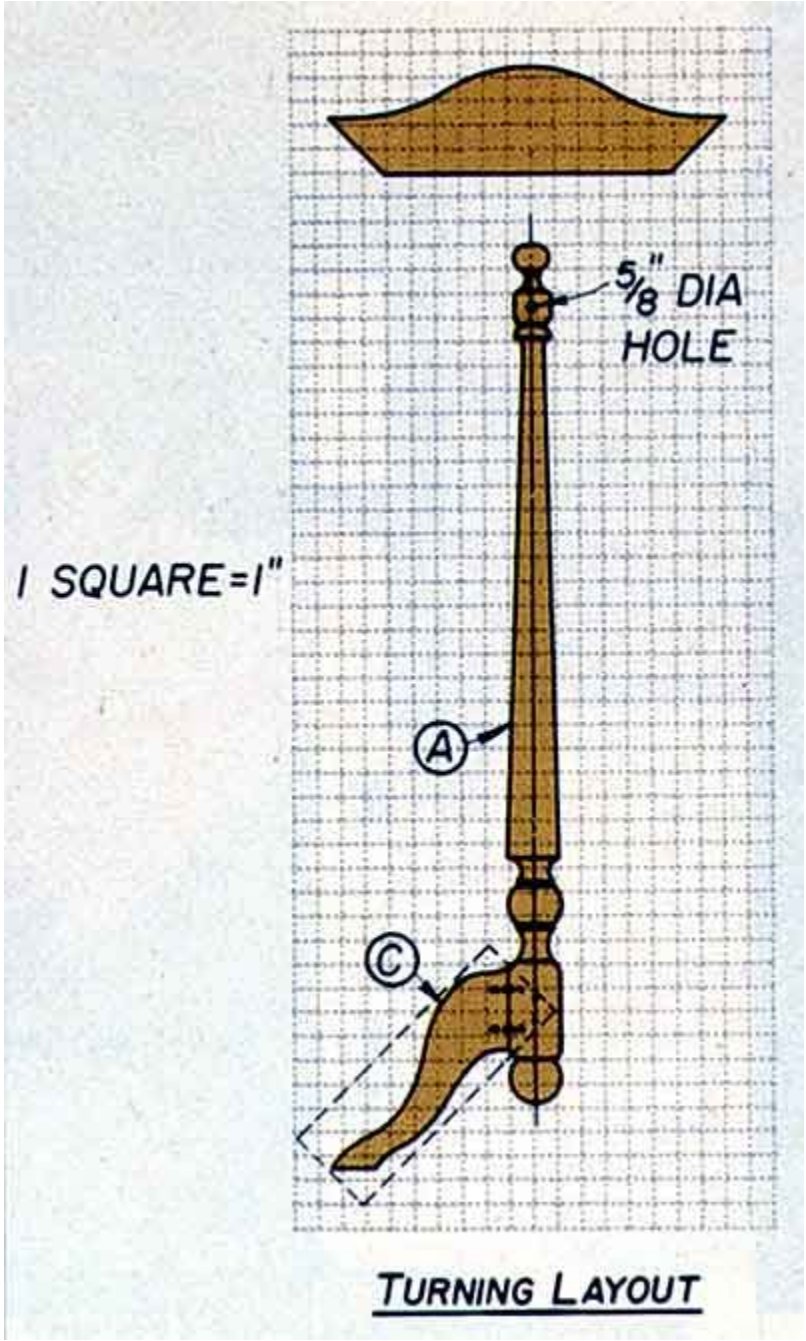

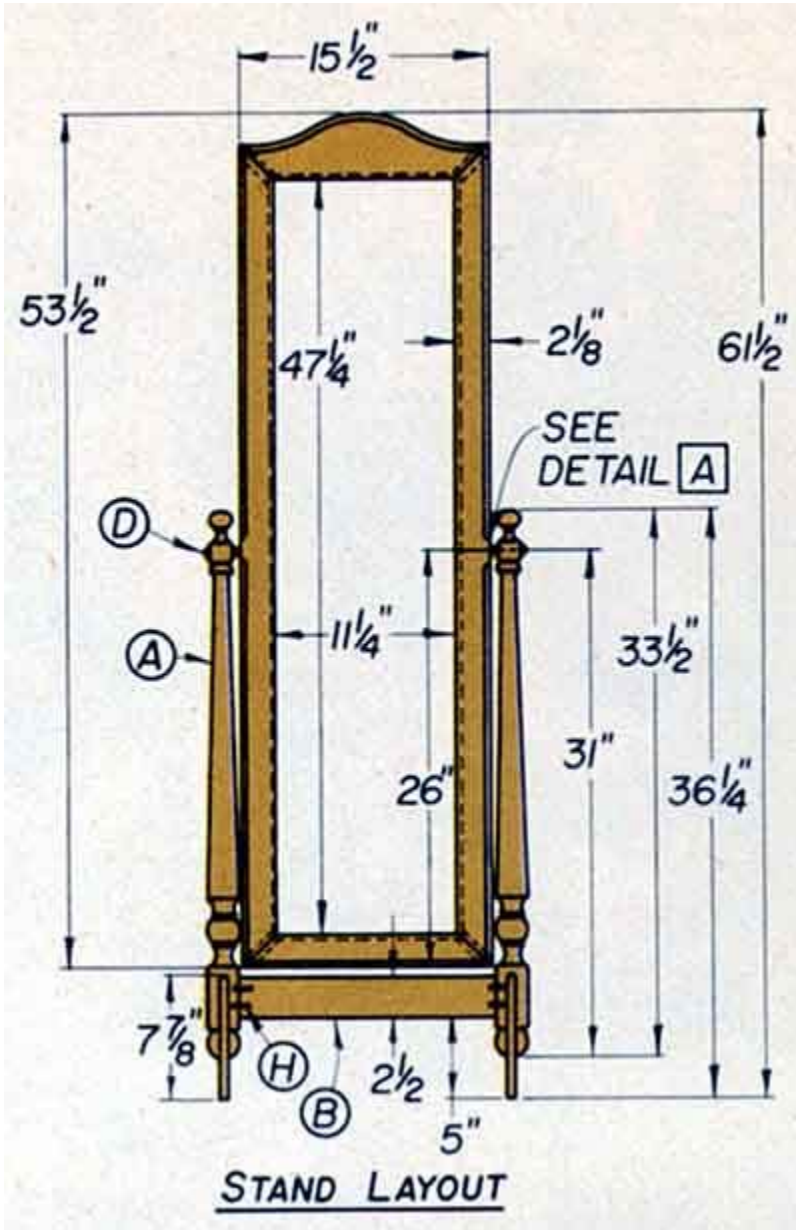

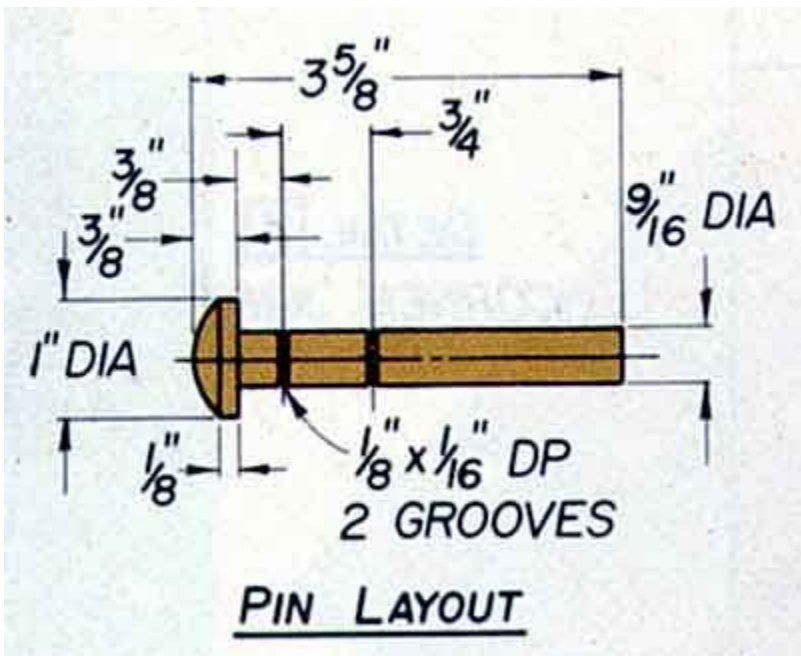

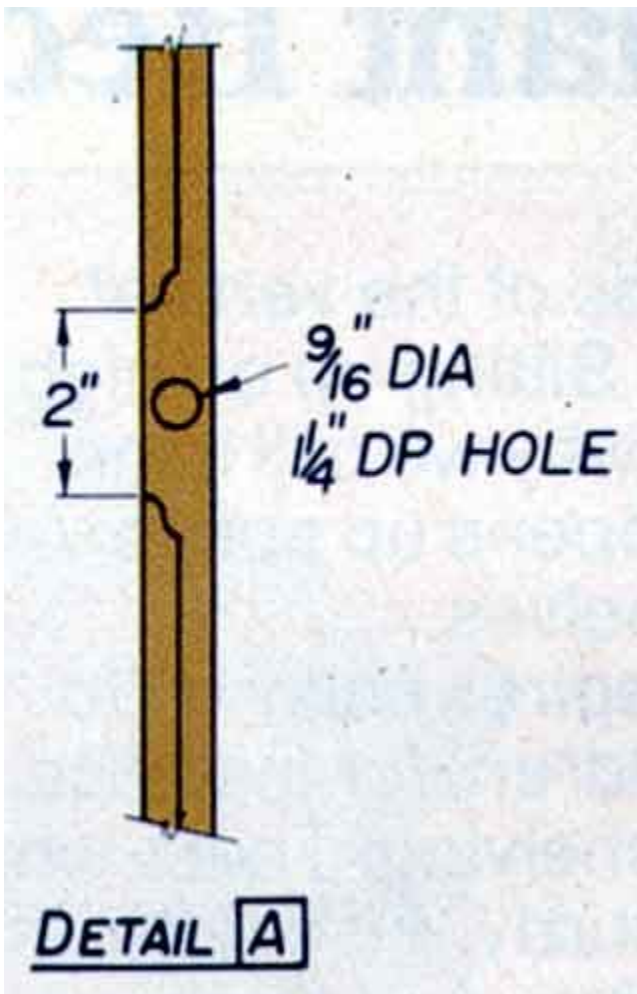

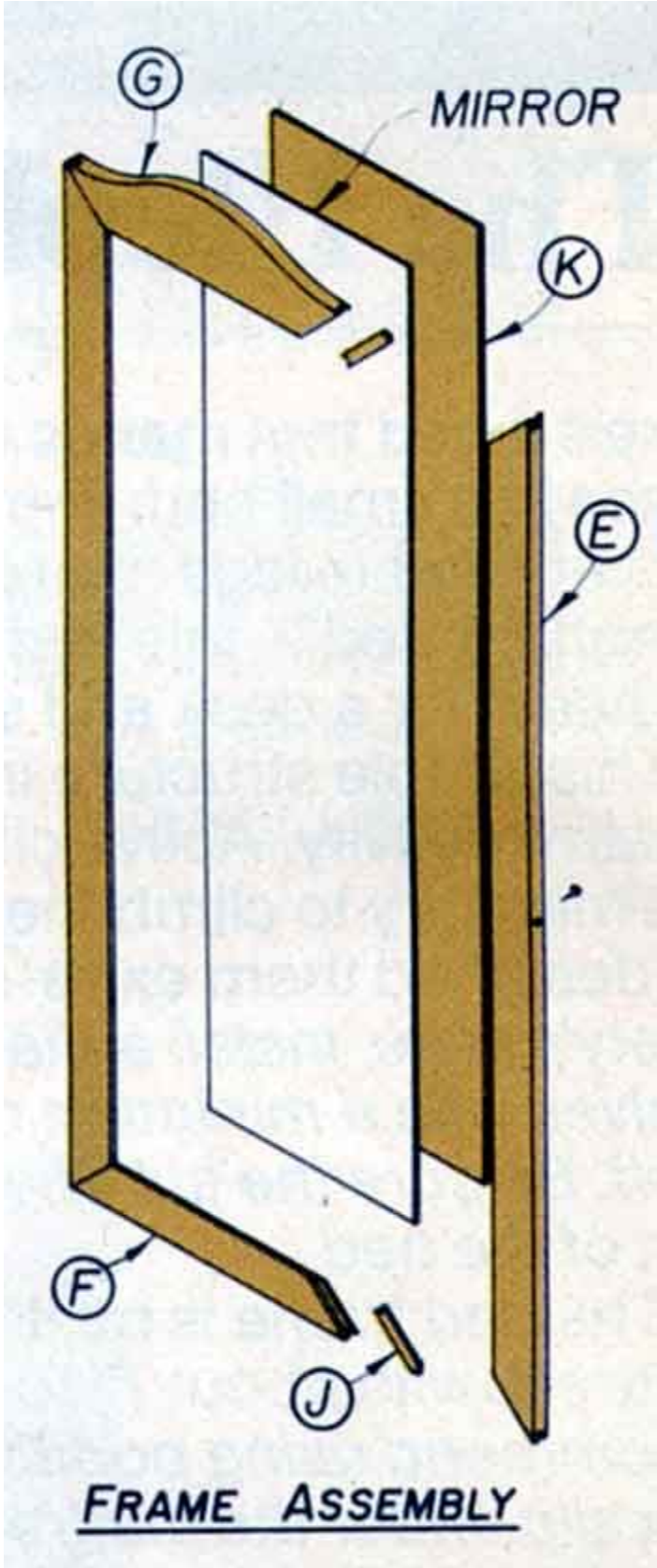

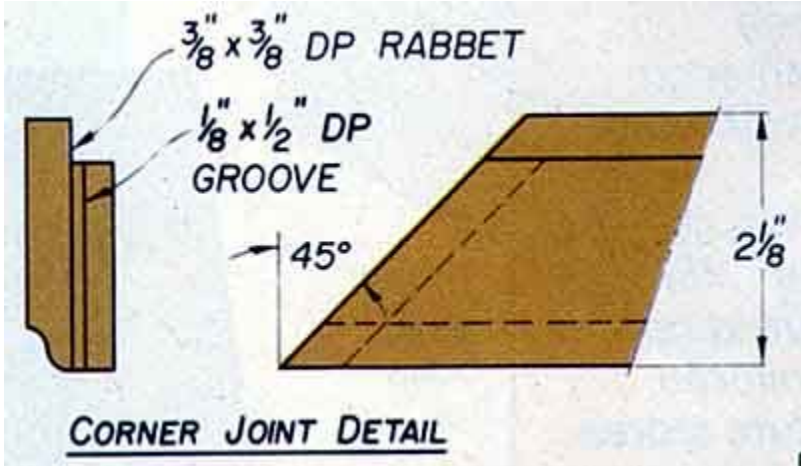

CHILD'S SLED



Here's a project that's as sure to be a big hit for a child or grandchild this Christmas as it is to be passed on to the next generation, and the next, and next. This classic sled will brighten any child's Winter blues, then double as a plant stand when "Old Man Winter" packs it in for the season. We've purposely made the shapes simple so it will be easy for you to duplicate them - or to modify them to a style you like better, if you prefer.

Start by drawing your patterns onto a piece of high quality 3/4" marine plywood (without voids). Be sure to draw two identical side pieces (B) and two identical runners (C).

Use your Table Saw to cut all pieces to size, then switch to a Dado set-up and cut:

- the 3/4" wide x 3/8" deep rabbets along the bottom edges of the sides (B)
- the 3/4" wide x 3/8" dados at the backs of the sides to accept the back
- the 3/4" wide x 3/8" deep rabbets along the top edges of the sides to accept the seat.

Switch to your bandsaw to cut out the shaped edges on the Sides (B), Runners (C) and Back (D). Use your Drum Sander to smooth the shaped edges prior to assembly.

Drill holes for the 1" dia. rope bar (E) and the 1-1/2" x #8 flathead wood screws that hold the aluminum glides to the bottom of the plywood runners.



Assemble with waterproof, two-part resorcinol glue and wood screws. Stain or paint to your preference, then apply a clear coat. **NOTE:** If painting, be sure to apply a coat of sealer prior to paint application.

LIST OF MATERIALS

(finished dimensions in inches)

A	Seat	12 x 24
B	Sides (2)	7 x 18
C	Runners (2)	8 x 36
D	Back	10-1/4 x 12-3/4
E	Rope Bar	1" dowel, 12-3/4 long
Miscellaneous		
(2)	Aluminum Glides 1/8" x 3/4" wide by (approx) 40" long	

CLIMBING BEAR



Here's a classic child's toy that's been around for generations. It's quick and easy to make...and a joy for the kids to play with. And you can make a stack of them at the same time by "pad-sawing" them out on your Bandsaw.

Start by cutting out your 5" x 5-3/4" blanks of 3/4" hardwood. We used poplar, but any good quality, clear wood will work nicely.

Next, make a photocopy of the pattern shown here and print it out to the appropriate size. Trace the pattern onto a piece of hardboard and cut out a tracing template that you can use for transferring the pattern to your workpieces.

Cut your bear blanks to size, fasten a stack of 4 or 5 of them together, using Double Stick Tape and cut the entire stack out at once on your bandsaw.

Now, cut out a top bar for each bear. Make them about 7" long x 3/4" wide by 3/4" thick. Use your drill press with the table tilted to 55-degrees to drill the 3/16" diameter holes in the bear's paws, as shown. Reset the table to 90-degrees and drill the holes in the top bars.

Use a straight-slot screwdriver to carefully separate the bears, then finish sand the bears and bars to a smooth surface using small drum sanders and a Strip Sander.

Add face decorations to one or both sides of the bears. Cut 1/8" diameter sash cord into pieces 50" and 8" long. To assemble, thread the 50" cords through the bears, bars and beads, then knot the ends. Use the 8" cords as center supports, passing them through the bead and center hole of the bar, then making a loop in the top end.

To make the bear climb, hang the support loop from a nail or a hook. First pull one cord, then the other, and the bear will "shimmy" up the ropes to the bar. Release both cords and the bear will slide back down.

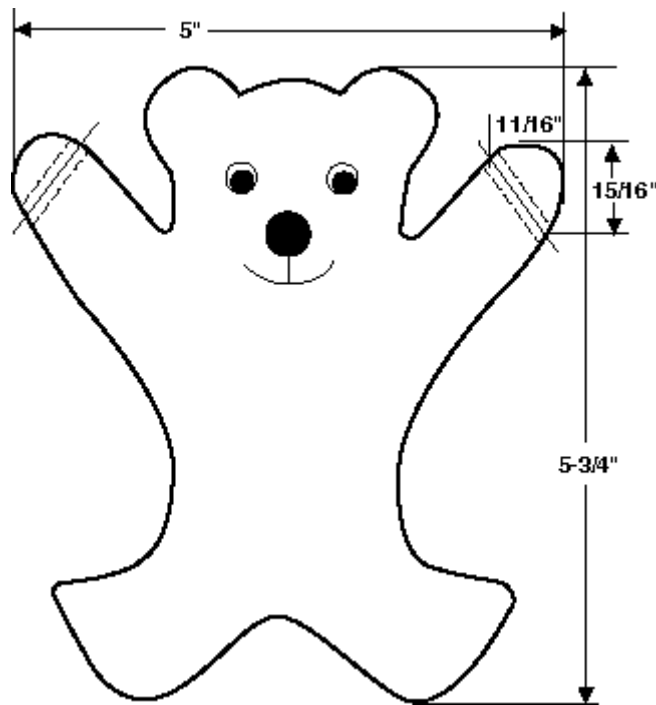



Extra Archive

CLASSIC ROLL TOP DESK



Have you ever considered building a major piece of furniture like this handsome roll top desk? It's not really difficult - just a matter of making some basic saw cuts, fitting, drilling, dadoing, gluing...operations that are basically very simple. The secret is -- TAKE YOUR TIME! Pay careful attention at every step along the way. "Measure twice and cut once." If you follow these simple rules of furniture construction, you'll be surprised at how smoothly the job will go, and how proud you'll be of the results you achieve.

Since this is a rather difficult project, we've decided to present the plans and procedures for building it in two parts. First, we'll tackle the pedestal desk base. Then, in the upcoming March/April edition of Hands-On, we'll build the roll top unit that goes with it.

Once the base is completed, you'll have an extremely functional and beautiful piece of furniture. Then, when the roll top section is finished and attached to the assembled desktop (no special joinery is required), you'll have a true family heirloom that you'll be proud to pass along to future generations.

1: Planning

The most important aspect of building any piece of furniture is planning. Start by looking over the printed plans very carefully. Read all the how-to information. Review the List of Materials and the drawings.

While you're looking over the plans, be sure to take some notes regarding special operations, tools you might be needing, assembly techniques and shop safety --- "building" the project in your mind, step-by-step.



The original plans for this desk were purchased from one of the major furniture plan developers, then modified to our liking after clipping photos of some desks we liked from magazines and other sources. Some minor changes were made to suit our special needs. For example, we used 3/4" lumber for the pedestal base pieces instead of the 1/2" used in the printed plan...then added three drawers on the roll top section.

We often use available project plans for certain projects, then modify their features and measurements to suit our special needs.

2: Getting Started

To build this project, you'll need two sheets of 3/4" oak veneer plywood. When buying the plywood, try to select two sheets with a similar grain pattern. For the drawers and other interior parts, you'll need some poplar or pine. Remember, if you select blemished or damaged materials when you're beginning, you'll probably wind up with discouraging results in the end. Choose your materials carefully. If you go to a lumber retailer who refuses to let you choose your pieces, walk out and go to a different lumber retailer who will.

3: Cut The Pedestal Sides (B)

Start by laying out the sides (B) and pull-out drawboards (P) on a piece of your 3/4" plywood. Make sure the grain direction follows the longest dimension of the parts. Start by cutting the plywood into manageable sized pieces, then trim them to their finished size. Shoptsmith's Crosscut Sliding Table will help you crosscut larger sized pieces with improved accuracy

4: Cut The Dadoes & Rabbets

Cut the dadoes & rabbets in the sides (B), using your Dado Attachment or Router Package. Note that all dadoes are to be cut to 1/4" deep. Since you'll be performing the same operation on a total of four pieces, keep your MARK V at the same setting until you finish the identical cuts on the remaining three.

5: Make The Dust Panels

Again, use production techniques to make all of the parts of these panels at once. First, rip parts D, E, F, G, H & J to the same width. Note that the edges of the (8) front frame pieces (D) will be exposed and therefore, should be made from the same wood as the exterior of the desk.



Next, cut the frame pieces to final length, then form a 1/4" wide by 1/4" deep groove in one edge of each piece. You'll need to take two of the front frame pieces (D) and form a groove on the top back side (see drawing detail "A").

Form 1/4" by 1/4" long stub tenons on the ends of the frame sides (F, G, H). Cut the 3/4" wide by 1/4" deep notches in the corners of the front frame pieces (D) to accept the pedestal facing strips (T).

Next, cut the plywood dust panels (U, V, W) to size and glue up the dust panel assemblies. Use yellow woodworker's glue, being careful not to get any glue on the plywood panels, since they should "float" loosely in the frame pieces. When clamping the pieces, make sure they remain square and flat. Set the center panel aside.

6: Assemble Dust Panels To Sides

Assemble dust panels to sides (B) with glue and clamps. The frames mount flush with the back edge of the sides. Be sure to line up the notches on the fronts of the frames with the front edges of the sides. Cut the bottom rails (C) to size and attach these with glue and 6-penny finishing nails.

7: Assemble The Remaining Parts Of The Base Pedestals

First, attach the pedestal facing strips (T) to the exposed edges of the sides. Next, cut the pedestal backs (Y) to size and attach with 2-penny nails.

Make the pedestal base pieces (L & M) and use your Shaper or Router Package to form a decorative edge on the tops of these pieces, if desired. If you're using a Shaper set-up, try the 1/4" and 1/2" Combination Quarter-Round Cutter or an Ogee Cutter. If you're working with your MARK V Router Package, you could use a 3/8" Round-Over Bit or the 5/32" Roman Ogee Bit. Miter the pieces to fit the Base, then use your Disc Sander to "shave" the mitered edges down for a perfect fit. Attach the pieces to the base with glue and 6-penny finishing nails. Use a nail set to countersink the nail heads, then fill the holes with a high-quality, stainable wood putty.

8: Assemble The Desk Case

Start by cutting the back apron (K) to size and then cutting the contoured lower edge with your Band saw or Scroll Saw. Drill three dowel holes in each end of the back apron (K) and locate their positions on the pedestals. A set of dowel centers will make easy work of accurately transferring the hole locations from the ends of the back apron to the sides (B) of the pedestals.



Once the hole locations are marked, you can use your hand-held drill to bore the dowel holes in the sides (B)

Next, cut the center frame supports (N) to finished dimension and attach them to the pedestal sides using #8 x 1-1/4" flathead wood screws. Attach the back apron with 3/8" dowel pins but do not glue them! Then, fasten the center dust panel to the frame supports with #8 x 1-1/4" flathead wood screws.

9: Make The Top (A)

We used veneered plywood for our top because plywood is straight, easy to work with and stable. When cutting this and other large plywood parts to final dimension, it's best to have someone assist you for added safety. If you don't have this option, be sure to use Roller Support Stands or a MARK V Support Table to help you hold and guide your stock through the cuts safely and accurately.

Once you've squared the top, drill four dowel holes into the top edges of each of the four pedestal sides...then drill mating stopped holes into the underside of the top (A). Again, an inexpensive set of dowel centers will save a lot of time in matching-up these hole locations.

Apply the edge strips (R & S) to the top with glue and 5/8" brads. A set of 3-way edge clamps will help you hold these edge strips in position until the glue sets-up.

Mount the top to the two pedestal sides with the dowels. If you choose not to use glue, you'll be able to remove the top from the pedestals easily for moving, if necessary.

10: Make The Drawers

Make the drawers following the drawings and the list of materials as guides. Since drawers look and work best when they're made to fit, dimensions given will vary slightly from the actual measurements. Be sure to measure twice before making any cuts.

Form the raised panels on the drawer fronts by tilting your MARK V saw table to 12-degrees and using a crosscut blade. You'll also need a raised panel jig for making this cut.

After forming the raised panels on the fronts, cut the required dados, rabbets and grooves for the remaining parts. Use production techniques to take full advantage of machine set-ups. Glue the drawers together, being



careful NOT to glue the drawer bottoms. Check for squareness as you assemble each drawer.

At this time, assemble the slide-out drawboards, glue and clamp. Use your Shopsmith Molding Set-Up with a Nosing cutter to form the finger pull on the drawboard nosing (Q).

11: Final Touches

Finish sand the entire project and apply the finish of your choice.

Compartmented Rolltop For Pedestal Desk Base

Here's the compartmented roll top for the Pedestal Desk base we presented in the January/February, 2003 edition of "Hands-On!". This attractive and functional topper offers a total of eight Drawers and 11 Cubbyholes that will help it soon become the virtual Center of Organization for your home or office. And, as with the Pedestal Base covered in our previous issue, you can build the Top using only basic woodworking operations.

The Roll top unit features two major components - 1) the Frame with its Tambour and 2), the Drawer/Cubbyhole insert. We suggest that you complete the Frame with the Tambour first, then build the insert. Let's get started.

1. Select Your Stock.

The materials for this unit should be cut as you progress through the construction steps. We used a high-quality, 3/4" oak veneer plywood for the Sides (D), but you could use solid 3/4" oak, glued up to the appropriate sizes, if you prefer. Just be careful to match the grain as closely as possible with the grain pattern on the Pedestal Sides you built in our last installment. NOTE: Whether you use plywood or solid wood, to achieve the best appearance, the grain direction on these Sides should be vertical.

2. Make the Roll top Frame.

Start by cutting out parts A through E, according to the List of Materials.

NOTE: If you're planning to use glued-up oak hardwood for the Top (A), make this assembled piece 13-1/2" wide instead of 13", since you won't be needing the Top Front Strip (B) to edge your plywood.

Next, make a cardboard template for the curved tops of the Sides (D), then transfer this pattern to your stock. Use double-stick tape to attach the two



Sides together temporarily so you can cut them both at the same time, using your Band saw, Scroll Saw or hand-held Saber Saw.

Once you've cut the curves on the two Sides (D), use your Drum Sander to smooth the edges. The Shoppersmith Oscillating Spindle Sander Attachment will make this smoothing job go faster and help you "get more mileage", out of your sanding sleeves, as well.

If you've used plywood to make your Sides, once you've cut them out, finish off all exposed edges (including the back edges and the curved top edges) using matching 3/4" oak veneer tape. Although you could use masking tape or duct tape to hold these veneer strips in position while they dry, special 3-Way Edging Clamps will do a much better job and provide access to the edges so you can wipe off any glue squeeze-out before it dries.

Make a Roll top groove template. Next, following the dimensions provided in the Side View Drawing, make a 1/4" or 3/8" thick hardboard or plywood template to guide your hand-held router as you cut the 9/16" wide x 3/8" deep groove on the insides of each Side (D) for the Tambour. Use a 9/16" diameter straight bit for this job and a router guide bushing with a 5/8" INSIDE diameter.

NOTE: The OUTSIDE diameter of these bushings is typically about 51/64", so you'll have to make your groove template dimensions slightly smaller than the actual groove dimensions shown on the Side View Drawing to compensate for this and be certain your finished grooves are positioned properly on the Sides. Here's a tip. IMPORTANT: To be sure your template is the correct size, subtract the difference between your router bit's radius and the outside radius of your Guide Bushing from the dimensions given for the track template.

Next, using your Dado Set-Up, cut the rabbets in the rear edges of the Sides (D) that will accept the back (E). Drill 3/8" or 1/2" dowel holes in the bottom edges of the Sides (D). You can either measure the locations of these holes very carefully or use dowel centers to transfer these hole locations to the Desktop once you're ready to attach the Roll top unit to the Pedestal Base.

3. Make the Dust Panel.

Cut out parts F through J for the Dust Panel. Cut the 1/4" grooves in the Rails (F) and Stiles (G) using your Dado Set-Up, your Shoppersmith Router Table Kit or Shoppersmith Pro Fence System Router Table with a 1/4" Straight Router Bit to form these grooves.



Next, form the tenons on the Rail ends. Your Dado Set-Up is the best tool for this job. Drill 1/4" or 3/8" dowel mounting holes in the outside ends of each end Rail (F) for mounting the assembled Dust Panel to the Sides (D). Again, you can either measure the locations of these holes very carefully or use dowel centers to transfer these hole locations to the Sides once you're ready to fasten the Dust Panel into position.

Assemble the Dust Panel with glue, but do not glue the plywood pieces (H & J) to the rails and stiles, so everything can expand and contract with changes in temperature and humidity without splitting.

4. Drawer Partitions.

Cut the Drawer Partitions (K) to size and drill two 1/4" or 3/8" dowel holes on each bottom and top edge. Locate and drill matching holes in the two mating inside Dust Panel rails (F).

5. Roll Top Frame Assembly.

Glue and clamp the Sides (D) and Dust Panel together...then glue the Drawer Partitions (K) in place. Drill the three dowel holes in the tops of each Side (D), and mating holes in the bottoms of the Top (A) ends...then assemble the Top (A) to the Sides (D) with glue and clamps. If you have made your Top (A) from 3/4" plywood, you'll need to attach the Top Front Strip (B) to the front edge of your Top (A) at this point. You can either screw this piece to the Top using counter bored #9 x 1" flathead wood screws covered with screw plugs...or simply glue it into position. Again, 3-Way Edging Clamps are the perfect tool for holding this piece in position while the glue sets up.

6. The Tambour.

Follow the steps outlined in the special Making Tambours sidebar article to create the Tambour for your desk.

7. The Insert.

To make the Insert, you'll either have to purchase 1/4" and 1/2" thick stock for the pieces or use your Band saw to resaw these pieces from thicker 3/4" stock, then run them through a Thickness Planer. The Back (O) can be made from 1/4" plywood.

Start by cutting all Insert parts (O through Z) to size. Next, carefully lay out all the rabbets and dados required for these pieces. Be sure to measure everything twice as the accuracy of all cuts is critical. Cut the dados and rabbets in parts P through Z. Using your Band saw or Scroll Saw, cut the



contours on the front edges of parts S, V and Y. Sand the scrolled edges carefully using your Drum sander.

Prior to assembly, mark all pieces for location. Begin the assembly process by gluing together parts P, Q, R & S. Next, glue and clamp the left Side pieces (T & Z) into position. Allow the glue to set up, then follow the same procedures for the right Side pieces (T, X, Y & Z).

8. Insert Drawers.

Cut out all Drawer parts (AA through HH). Using your Dado or Route set-up, cut the 1/4" grooves and dados in the Drawer sides and fronts, as shown in the Drawer Construction drawings. Tilt your Saw Table to 15-degrees and bevel the edges of the Drawer Fronts to create a raised panel look.

CAUTION: This is a potentially dangerous operation since the parts are small. Be sure to use a combination of Push Blocks, Push Sticks and Feather Boards to keep your hands clear of the Saw Blade at all times.

A Panel Raising Jig will make this job much simpler and safer. Assemble the Drawers with glue, then use your Belt Sander to smooth them to finished dimension.

9. Top Drawers.

A locking drawer joint is used on the Top Drawers (see Top Drawer Construction drawing). For parts JJ through QQ, repeat the same construction procedures as in step 8.

10. Finishing.

Prior to final assembly, apply the finish of your choice to the Insert, Tambour and Frame.

11. Assembly.

Insert the Tambour into the grooves in the Sides (D). Attach the Roll top to the Desktop with dowels, but do not glue, as this makes the desk easier to disassemble in the event you have to move it. Have someone help you lower the assembled Roll top onto the dowel holes in the Desktop.

Next, attach the Bottom Rail (C) to the Desktop using #9 x 1-1/4" flathead wood screws. Nail the back (E) into place using small brads or 2-penny nails. Finally, select and install the hardware of your choice and enjoy!



LIST OF MATERIALS

(finished dimensions in inches)\

DESK CASE		
A	Top	3/4 x 29-1/2 x 51-1/2
B	Sides (4)	3/4 x 28 x 29-1/4
C	Bottom Rails (4)	3/4 x 3-5/8 x 13-1/4
D	Front Frame Pcs.* (8)	3/4 x 2-1/4 x 13-3/4
E	Back Frame Pcs.* (8)	3/4 x 2-1/4 x 13-3/4
F	Bottom Side Frame (4)	3/4 x 2-1/4 x 24-1/2
G	Upper Frames (12)	3/4 x 2-1/4 x 24
H	Center Frame (2)	3/4 x 2-1/4 x 21
J	Center Frame Sides (2)	3/4 x 2-1/4 x 22-1/2
K	Back Apron	3/4 x 5-5/8 x 21
L	Pedestal Base (4)	3/4 x 4 x 15-3/4
M	Pedestal Base Sides (4)	3/4 x 4 x 29-1/2
N	Center Fram Supports (2)	3/4 x 3/4 x 25-3/4
P	Drawboard (2)	3/4 x 12-5/8 x 26-1/4
Q	Drawboard Nosing(2)	3/4 x 3/4 x 13-1/8
R	Top Edge Strips(2)	1/4 x 3/4 x 52
S	Top Edge Strips(2)	1/4 x 3/4 x 30
T	Pedestal Facing Strips (8)	1/4 x 3/4 x 29-1/4
U	Upper Dust Panels (4)	1/4 x 9-3/4 x 24
V	Lower Dust Panels (2)	1/4 x 9-3/4 x 24-1/2
W	Center Dust Panel	1/4 x 3/4 x 12-5/8
X	Drawerboard Edge Strips(4)	1/4 x 3/4 x 12-5/8
Y	Pedestal Backs(2)	1/4 x 13-3/4 x 25-1/8

DRAWERS		
AA	Drawer Fronts (8)	3/4 x 5-1/2 x 13-3/4
BB	Center Drawer Front	3/4 x 4-7/16 x 20-7/8
CC	Center Drawer Sides (2)	1/2 x 3-3/16 x 23-1/2
DD	Center Drawer Back	1/2 x 2-7/16 x 20-3/8
EE	Drawer Sides (8)	1/2 x 5-3/16 x 23-3/4
FF	Drawer Backs (4)	1/2 x 4-7/16 x 12-5/8
GG	File Drawer Sides (4)	1/2 x 11-3/16 x 23-3/4
HH	File Drawer Backs (2)	1/2 x 10-3/8 x 12-5/8
JJ	File Drawer Joiners (2)	1/2 x 1-1/4 x 13-3/4
KK	Center Drawer Bottom	1/4 x 20-3/8 x 23-3/8



LL	Drawer Bottoms (6)	1/4 x 12-5/8 x 23-5/8
----	--------------------	-----------------------

*Front Frame Pieces (D) are exposed and should be made out of the same stock as the rest of the exterior. Back Frame Pieces (E) are NOT exposed and therefore may be made of secondary wood.

LIST OF MATERIALS

(finished dimensions in inches)

DESK CASE		
A	Top	3/4 x 13 x 53*
B	Top Front Strip	1/2 x 3/4 x 50*
C	Bottom Rail	3/4 x 4-1/8 x 50
D	Sides (2)	3/4 x 18 x 28-1/2
E	Back	1/4 x 18 x 50-3/4
F	Dust Panel Rails (4)	3/4 x 1-1/2 x 9-1/4
G	Dust Panel Stiles (2)	3/4 x 1-1/2 x 50
H	End Dust Panels (2)	1/4 x 9-1/4 x 17
J	Center Dust Panel	1/4 x 9-1/4 x 11-1/2
K	Drawer Partitions (2)	3/4 x 4-1/8 x 11-3/4
L	Tambour Strips (27)	3/4 x 3/4 x 50-5/8
M	Tambour Bottom	3/4 x 2 x 50-5/8
N	Canvas Cover Strip	1/4 x 3/4 x 49-3/4

INSERT		
O	Back	1/4 x 8-1/2 x 49-3/4
P	Top	1/2 x 8-1/2 x 49-3/4
Q	Panels (4)	1/2 x 8-1/2 x 10-5/8
R	Bottoms (2)	1/4 x 4-3/8 x 8-1/2
S	Scrolled Divider	1/4 x 8-1/2 x 10-1/2
T	Panels (5)	1/4 x 8-1/2 x 12-1/2
U	Panel	1/4 x 8-1/2 x 14-1/4
V	Scrolled Panel	1/4 x 8-1/2 x 1-1/4
W	Partitions (2)	1/4 x 2-3/4 x 8-1/2
X	Partition	1/2 x 4-3/4 x 8-1/2
Y	Scrolled Dividers (3)	1/4 x 4-3/4 x 8-1/2
Z	Partitions (2)	1/2 x 7-3/8 x 8-1/2



SMALL INSERT DRAWERS		
AA	Fronts (3)	1/2 x 2-7/16 x 4-7/16
BB	Backs (3)	1/4 x 1-15/16 x 4-3/16
CC	Sides (6)	1/2 x 2-7/16 x 8-3/16
DD	Bottoms (3)	1/4 x 4-3/16 x 8-3/16

LARGE INSERT DRAWERS		
EE	Fronts (2)	1/2 x 2-3/16 x 12-1/8
FF	Backs (2)	1/4 x 1-15/16 x 11-7/8
GG	Sides (4)	1/2 x 2-3/16 x 8-3/16
HH	Bottoms (2)	1/4 x 11-7/8 x 8-3/16

SIDE TOP DRAWERS		
JJ	Fronts (2)	3/4 x 4-1/16 x 19-1/8
KK	Backs (2)	1/4 x 3-9/16 x 17-7/8
LL	Sides (4)	1/2 x 4-1/16 x 11
MM	Bottoms (2)	1/4 x 10-3/4 x 17-7/8

CENTER TOP DRAWERS		
NN	Front	3/4 x 4-1/16 x 12-3/8
OO	Back	1/4 x 3-9/16 x 11-1/8
PP	Sides (2)	1/2 x 4-1/16 x 11
QQ	Bottoms	1/4 x 10-3/4 x 11-1/8

*NOTE: If you're planning to use glued-up oak hardwood for the Top (A), make this assembled piece 13-1/2" wide instead of 13", since you won't be needing the Top Front Strip (B) to edge your plywood.

A Tambour is a sliding door that consists of narrow strips of wood glued to a piece of canvas. This allows the door to flex, conforming to a groove cut in two mating side pieces as it "rolls" up and down to open or close.

Tambours are typically used for Roll top Desks, Bread Boxes, countertop "garages" for small kitchen appliances, etc. They add a touch of the unusual and a sense of "flair" to a piece of furniture.



To make a Tambour like the one on our Roll top Desk, just follow these simple, step-by-step instructions.

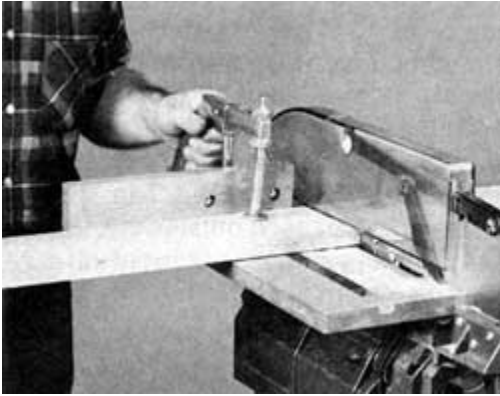

Step 1 - Cut the Tambour stock to length. Using your MARK V Table Saw set-up, prepare your Tambour stock by first crosscutting your wide stock to the desired finished length. For proper support, it's a good idea to use a Miter Gauge Extension for this operation. We also suggest that you prepare a few pieces of extra stock for set-up and to allow for any defects in your material or warpage which could occur once the strips have been cut.

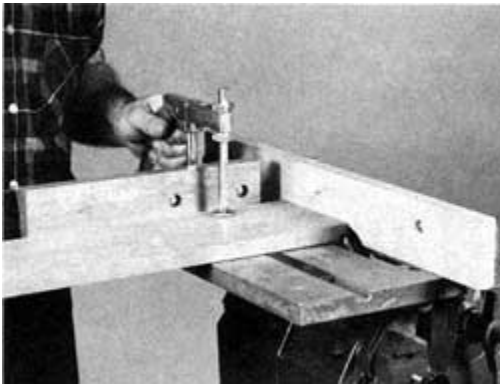

Step 2 - Cut the rabbets. Using your Dado set-up and a wooden shop-made auxiliary Rip Fence face, cut the rabbets that will form the tongues on the ends of your wide stock. These tongues will later slide into the grooves on the Tambour frame of your project. Allow 1/16" to 1/8" of clearance between the tongues and the grooves. For example, if your grooves are to be 9/16" wide, make your tongues 7/16" to no more than 1/2" thick.

Also, the end pins should be slightly longer than the depth of your track grooves to keep the "shoulders" of your Tambour slats from rubbing against the Sides as the Tambour is rolled up and down.



Step 3 - Rip the Tambour Strips to width. Again, using your Table Saw, rip your wide pieces of Tambour stock into the desired widths. Remember that the smaller your project, the narrower and thinner your Tambours should be.

CAUTION: Be sure to use a Feather Board and a Fence Straddler to keep your hands out of harm's way during this operation.

To allow for sanding, make your strips about 1/32" wider than your desired finished dimension. Allow the strips to "cure" and acclimate overnight so that any potential warpage becomes apparent to you.



Step 4 - Bevel the Tambour Strip edges. Both edges of each Tambour strip must be beveled to allow the strips to bend properly as the Tambour Top is opened and closed. First, discard any warped strips. Next, set up your Disc Sander, tilt your MARK V's Worktable to 5-degrees and offset the Rip Fence according to the directions in your MARK V Owner's Manual or your copy of "Power Tool Woodworking for Everyone". Use the MARK V's Quill to adjust the Sanding Disc's position properly. To complete your bevels, make two passes on each side of each Tambour strip.

Once you've finished, use a file or rasp to round each edge of your Tambour pins so they'll slide more smoothly in your track.

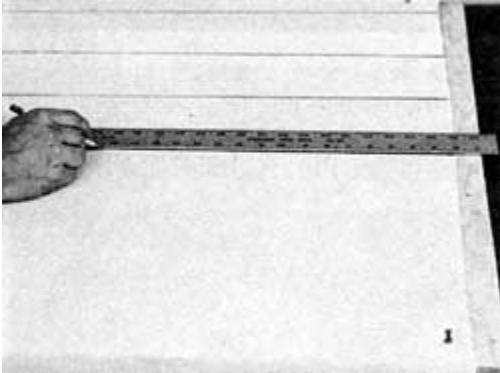

Step 5 - Prepare the canvas for gluing. Start by cutting your canvas about one foot longer than the Tambour when the strips are laid together...but one inch narrower than the width of the individual strips (rabbet-to-rabbet).

Tack your canvas to a flat surface. Draw a series of parallel lines that are square to the canvas edges to help you align the strips as you position them. As an option, you can clamp two pieces of straight wood to your benchtop at an exact 90-degree corner angle and use this as a guide to help you align the Tambour Strips on your canvas.

Step 6 - Glue the Tambour strips to the canvas. Apply a thin, even coat of contact cement to the back side of each Tambour strip...and to your canvas. Contact cement is better than yellow woodworker's glue since it remains fairly flexible once it dries. Allow the cement to dry, following the glue directions. If you like, you may apply a second coat to both the Tambour strips and the canvas. Again, allowing it to dry thoroughly. Carefully position each strip square to the canvas and butted up against one another, starting at the top and keeping all the ends lined-up as you go.

Once all of the strips are in place, turn the assembled Tambour over and press down on the canvas to be sure they're adhering properly. Place the Tambour bottom in position and screw a wood strip to it from the back side. Trim off any excess canvas and give your Tambour a trial fit. If it doesn't slide smoothly, a little filing or sanding may be all that's required. To help the "glide", rub a little candle wax or paraffin into your tracks.

Apply the finish of your choice, being careful not to saturate the canvas, as this will weaken the glue bond between the Tambour Slats and the canvas.

Install the Tambour.

Assembly

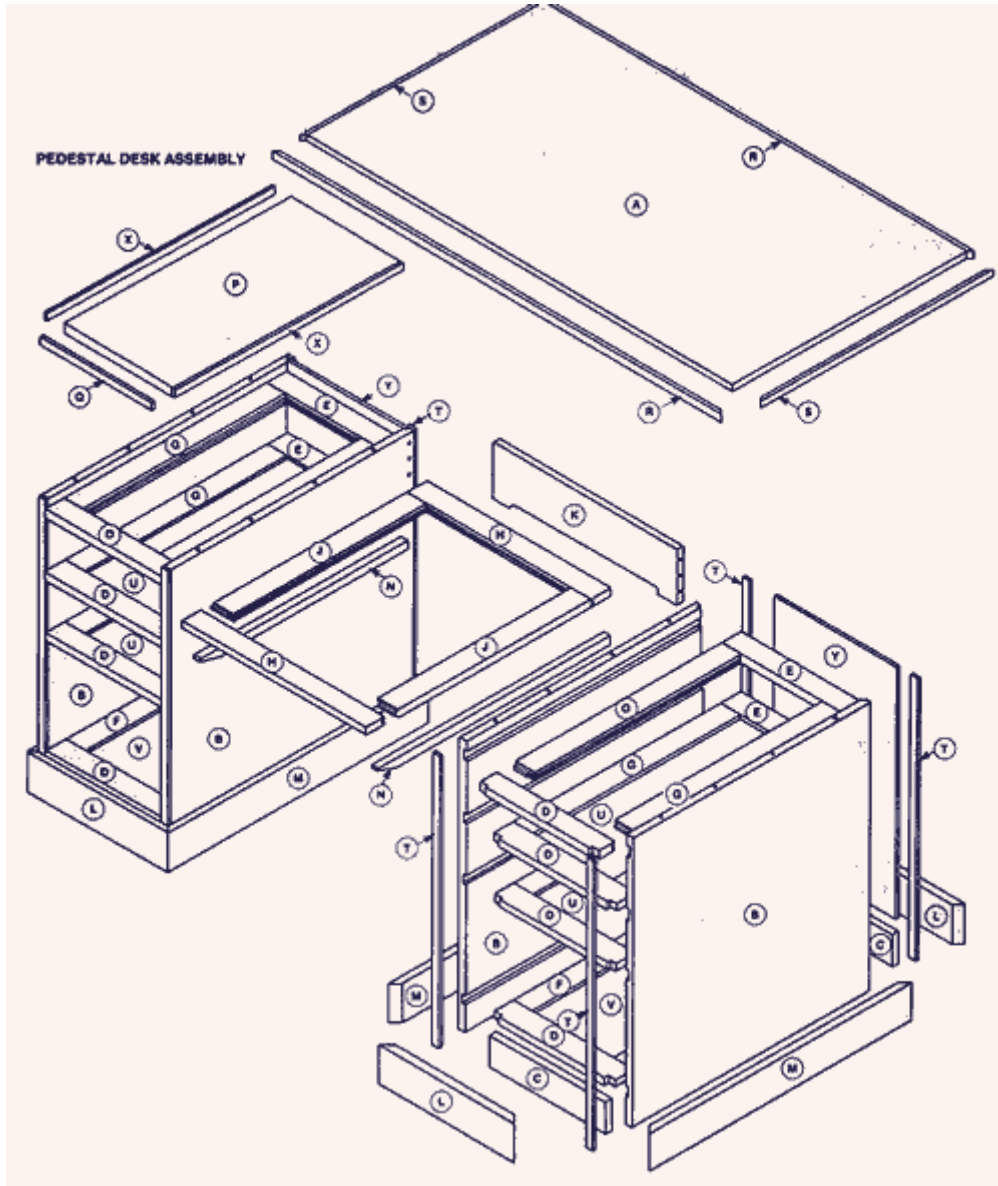

Pedestal Back - Top View

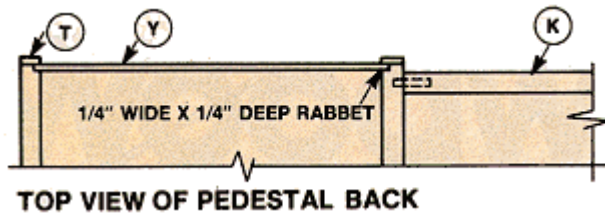

Top View

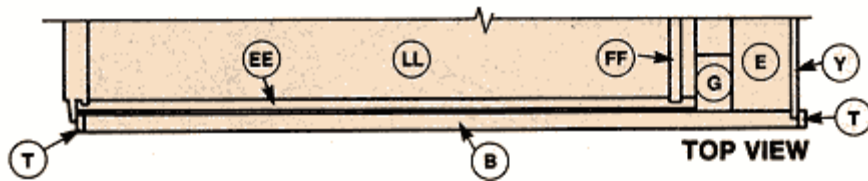

Front View

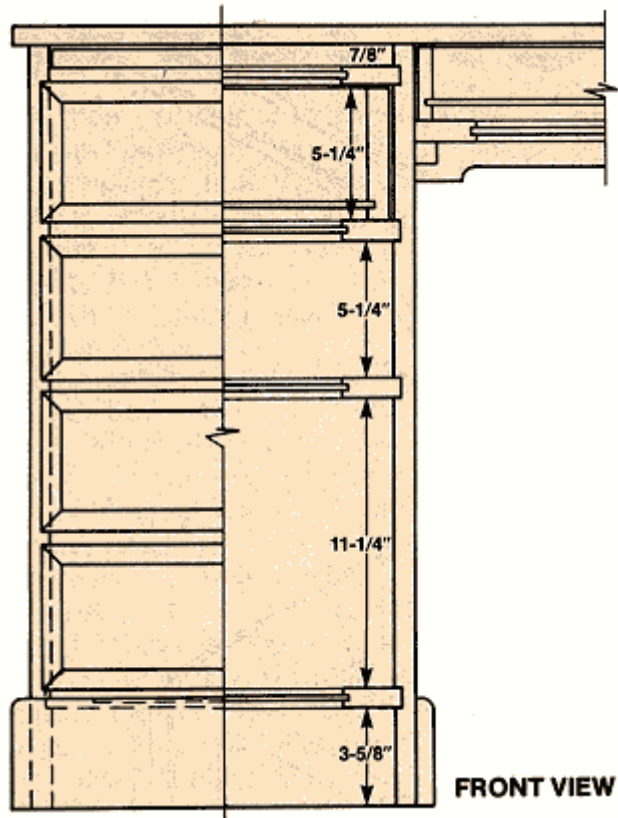

Pedestal Side View

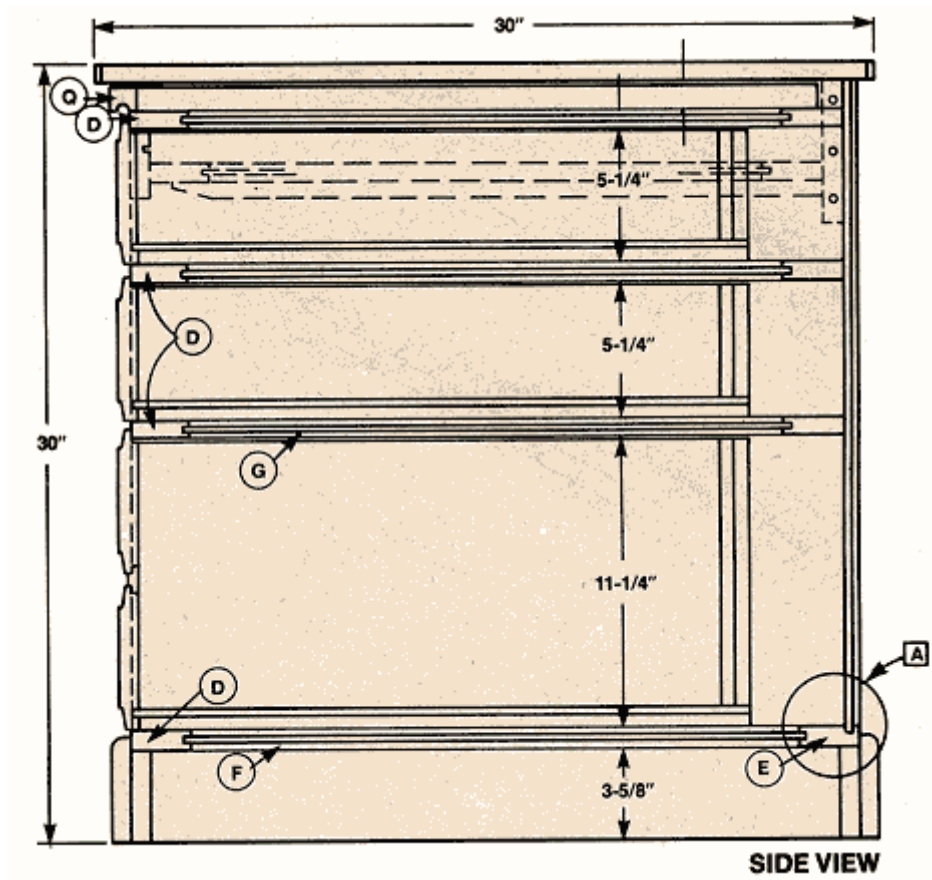

Side View of Pedestal

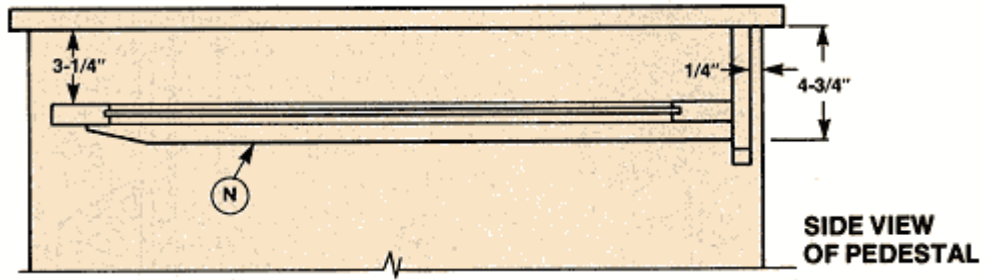

Bottom Back Frame Detail

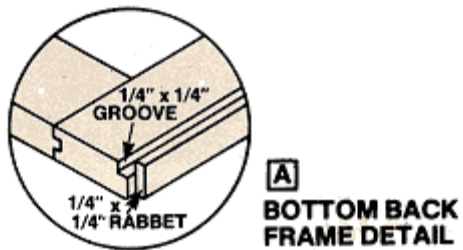

Center Drawer Assembly

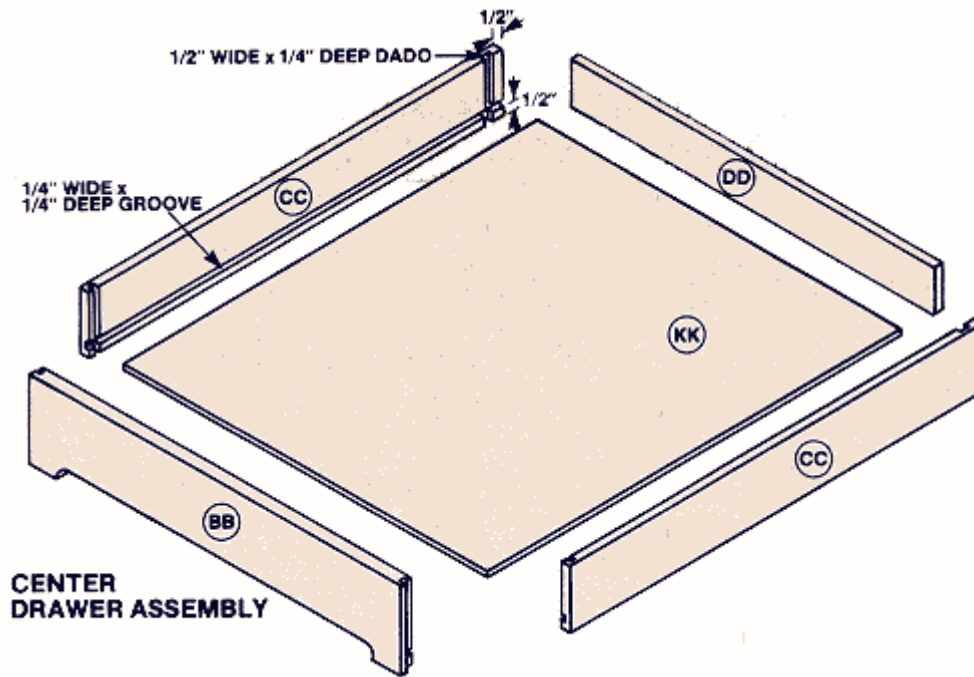

Drawer Assembly

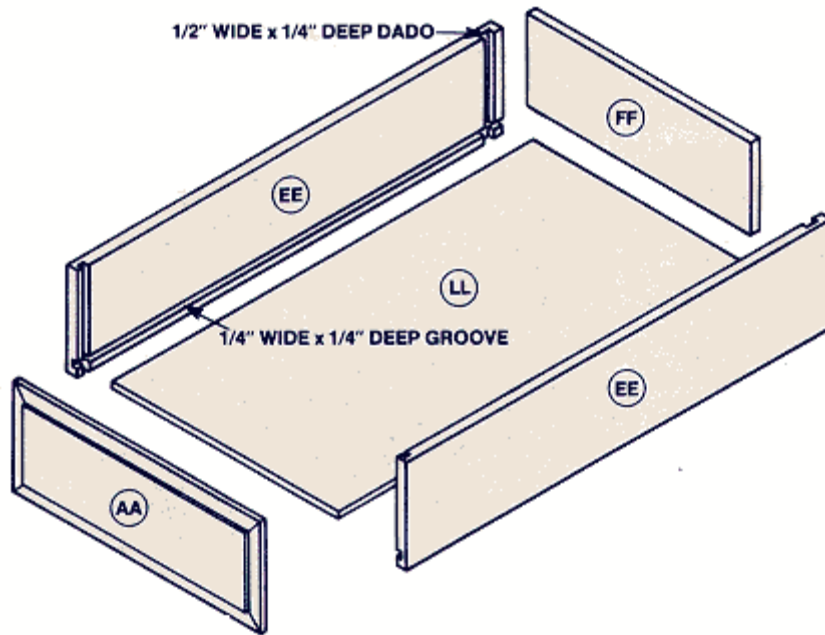

DRAWER ASSEMBLY

Detail of File Drawer Assembly

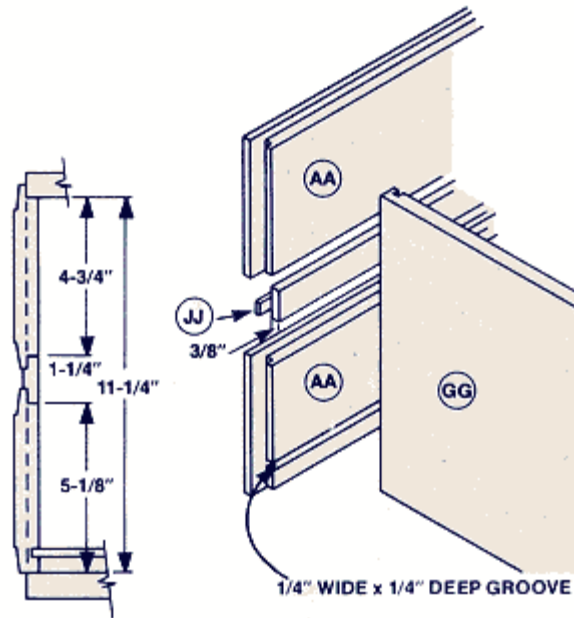

DETAIL OF FILE DRAWER ASSEMBLY

Drawer Details

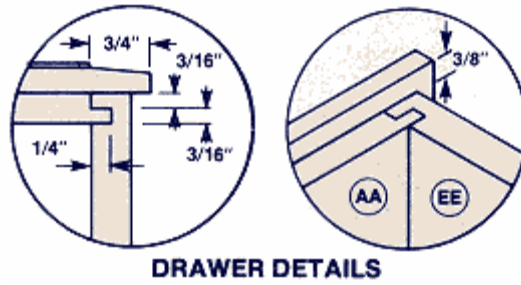

Center Drawer Detail

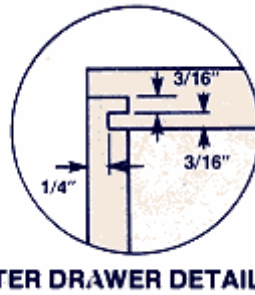

Side View

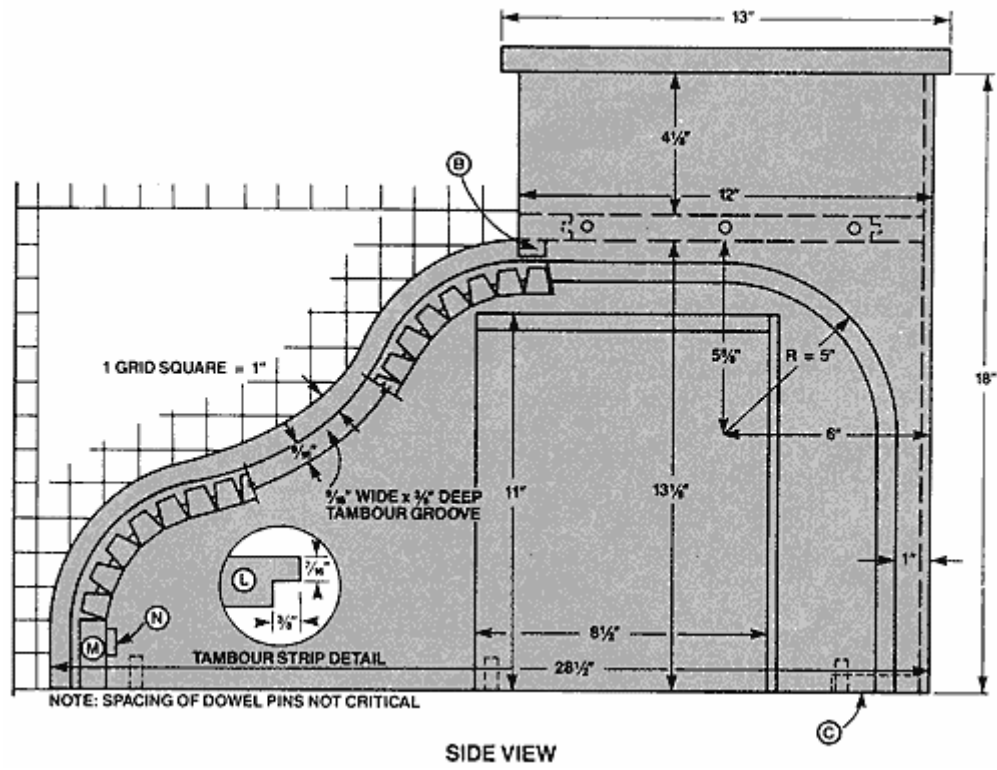

Typical Top Drawer Construction

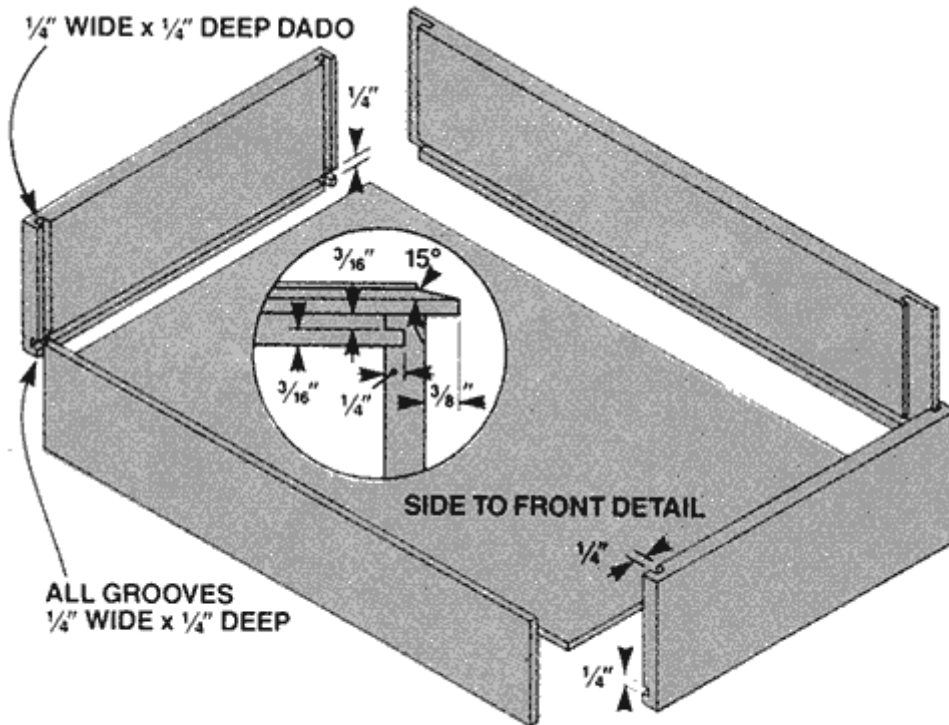

TYPICAL TOP DRAWER CONSTRUCTION

Typical Insert Drawer Construction

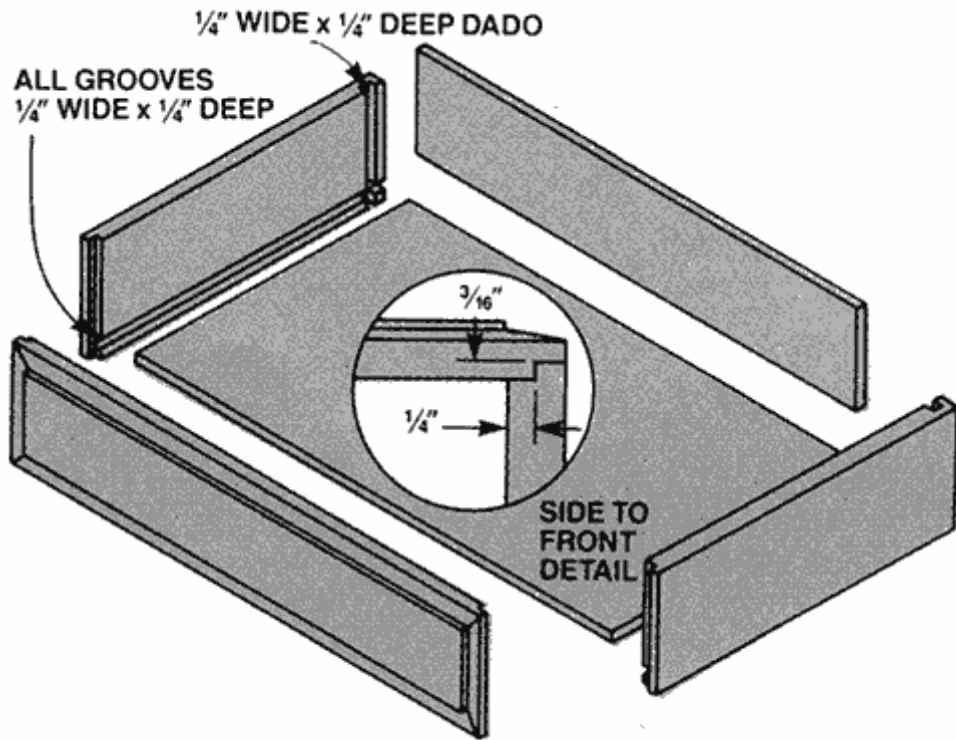

TYPICAL INSERT DRAWER CONSTRUCTION

Front View

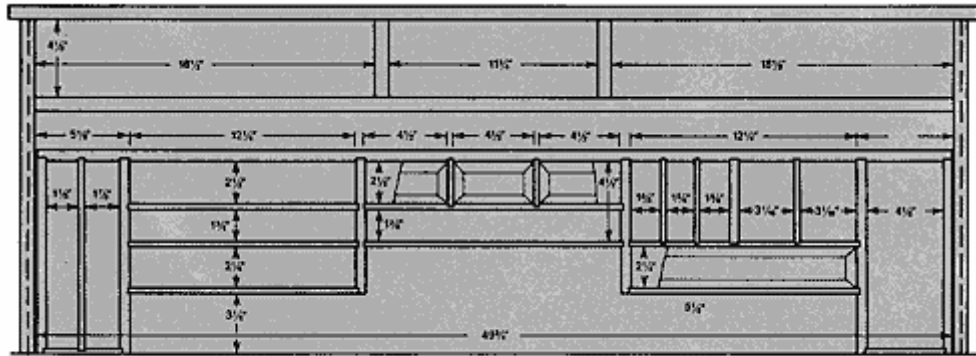

FRONT VIEW

Scroll Details

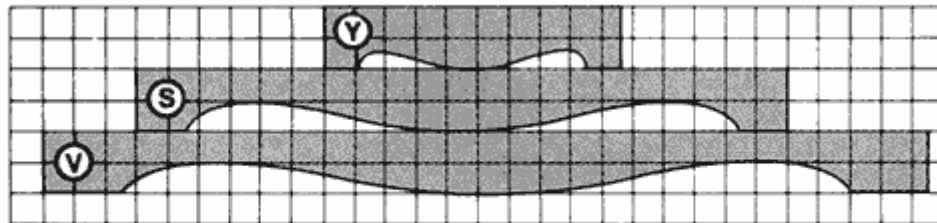

1 GRID SQUARE = 1/2"

SCROLL DETAILS

Rolltop Assembly

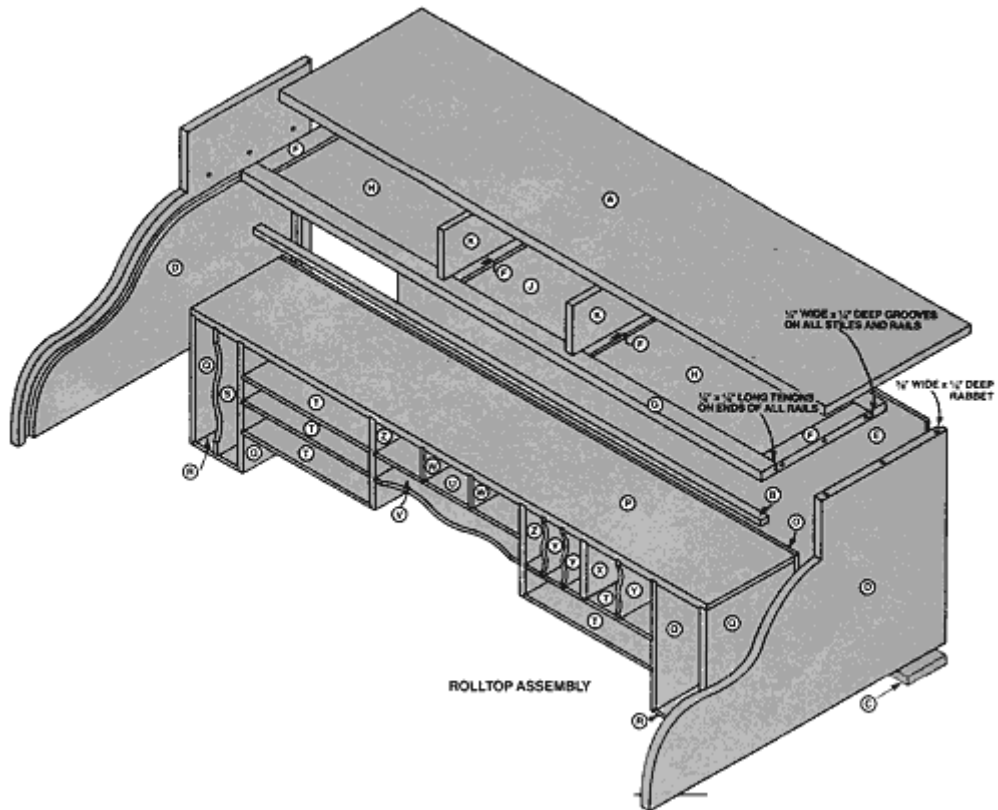

16-DRAWER APOTHECARY CHEST



Here's a great piece of furniture that will solve a BIG storage problem - where to put those sewing supplies, scissors, decks of cards, cassette tapes and dozens of other "odds-n-end" items that seem to keep cluttering up the house. Designed to resemble the chests used in old-time drugstores, this Apothecary Chest has 16 generous sized drawers to accommodate lots of things.

We built our chest out of #2 common pine throughout, except for the hardboard back and drawer bottoms...but poplar, cherry, oak or virtually any wood will look great. If you like, you can even save some money on materials by using particleboard for the partitions and plywood for the drawers.

1: Cut out the Sides (A), Top (B), Base Pieces (G & H), and Drawer Fronts (K). This will allow you to select the most attractive wood for the visible parts. Be sure to cut the drawer fronts (K) to about 1/8" oversize, since the finished drawer sides and bottoms are sanded flush after final assembly.

2: Cut the remaining stock to size, according to the list of materials. We glued-up the 14" wide partitions (C) out of solid pine, but you could also make these partitions out of 13-1/4" wide particleboard or plywood, then glue and nail a 3/4" x 3/4" strip of pine (or matching wood) facing to the exposed edge.

3: Form the 1/4" deep by 3/8" wide rabbet in the back edges of the sides (A) to accept the chest back (J). You can do this by making two cuts with an ordinary saw blade...or by using your Dado Set.



4: Attach the drawer guides (E) to the partitions (C) with 4-penny finishing nails and glue. Mount the guides flush with the back edges of the partitions, being sure to leave a 6-1/16" spacing between each guide. We temporarily positioned a 6-1/16" wide piece of scrapwood between each guide during assembly to maintain the exact distance. Attach the 3/4" x 3/4" filler strip (D) to the top partition.

5: Assemble the sides (A) and partitions (C) with glue and 8-penny finishing nails. Be sure to double-check your spacing to make sure you have 6-1/16" of vertical spacing between each partition. Glue the drawer dividers (F) into place.

6: Shape the edges of the top (B) and the drawer fronts (K) with your Shaper set-up and 1/4" Quarter-Round Shaper Cutter. As an option, you could also use your Router Package with a 1/4" Router Chuck and a Round Over Bit. Shape just the sides and front edge of the top.

7: Attach the top (B) to the case, using 8-penny finishing nails - then attach the back (J) with 2-penny common nails or small brads.

8: Miter the corners of the base pieces (G & H). Cut the scrollwork using your Bandsaw or Scroll Saw . Once you've made the cuts, smooth them with your Drum Sander. Attach the base pieces, using 4-penny finishing nails and glue.

9: Make the drawers. With 16 of them to make, you'll need to use a few "production" techniques to speed the process up a bit. Start by first ripping all of your drawer stock to the proper widths, then cross cutting the pieces to equal length. Shoppersmith's 24" Extension Face offers an adjustable stop that will help you cut all the pieces to the same length quickly. Just attach it to your Miter Gauge Face and go to work. Next, use any saw blade with a 1/8" kerf to cut the grooves in the drawer sides (L) for the drawer bottoms (N). Glue and nail the drawers together, then glue and clamp the fronts (K) into the ends (M) . Flush-sand the drawer bottoms and sides using your Disc Sander or Belt Sander. Slide in the bottoms (N) and tack them in place with 2-penny finishing nails or small brads. **Do not glue the drawer bottoms.**

10: Finishing touches. Set all exposed nail or brad heads and fill with a high-quality, stainable wood putty. Finish sand the chest then remove all dust with a tack cloth. Apply the stain and clear finish of your choice, attach the knobs and enjoy.



LIST OF MATERIALS

(finished dimensions in inches)

The Pieces:		
A	Sides (2)	3/4 x 14-1/4 x 30-1/4
B	Top	3/4 x 15 x 31
C	Partitions (5)	3/4 x 14 x 28
D	Filler Strip	3/4 x 3/4 x 28
E	Drawer Guides (12)	3/4 x 3/4 x 12-1/2
F	Drawer Dividers (12)	3/4 x 1-1/2 x 6-1/16
G	Base Front	3/4 x 4-1/4 x 31
H	Base Sides (2)	3/4 x 4-1/4 x 15
J	Back (Plywood or hardboard)	1/4 x 28-3/4 x 28-3/4
K	Drawer Fronts (16)	3/4 x 6 x 6
L	Drawer Sides (32)	1/2 x 5-7/8 x 13-3/4
M	Drawer Ends (32)	1/2 x 5-1/2 x 5
N	Drawer Bottoms (16) (Hardboard)	1/8 x 5-3/8 x 13-3/4

White porcelain knobs (16)

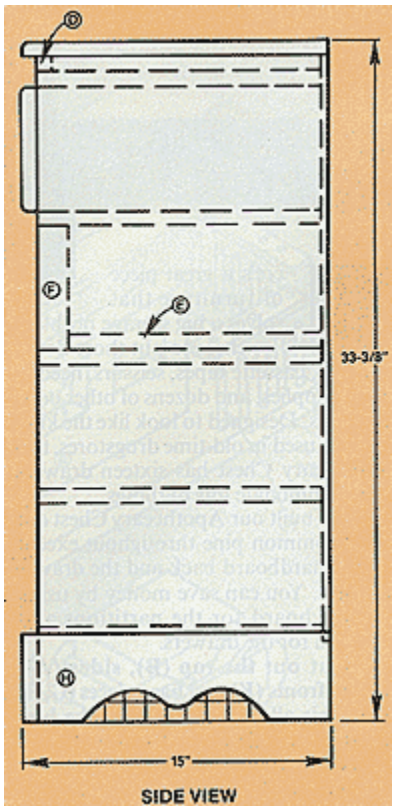
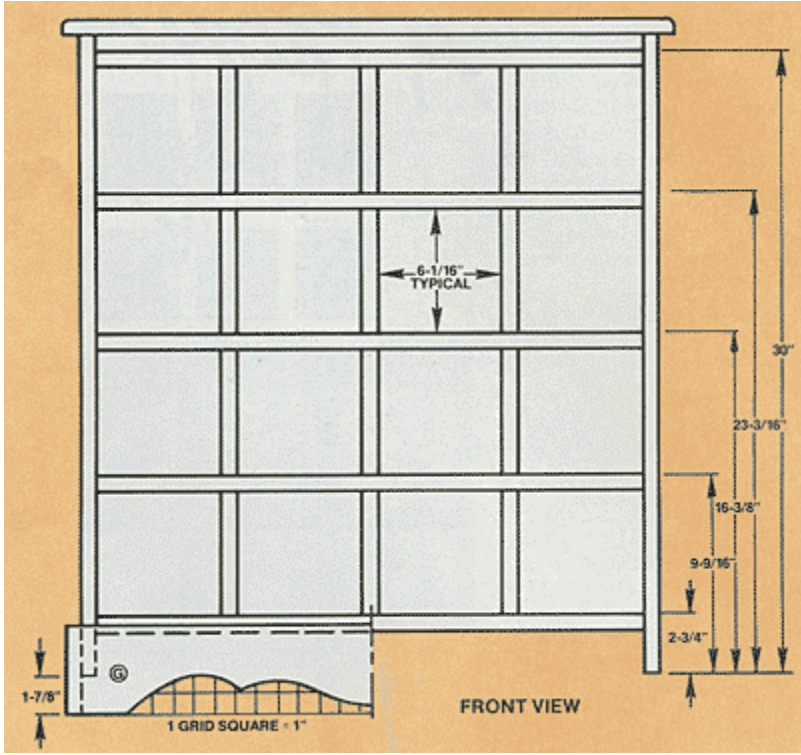

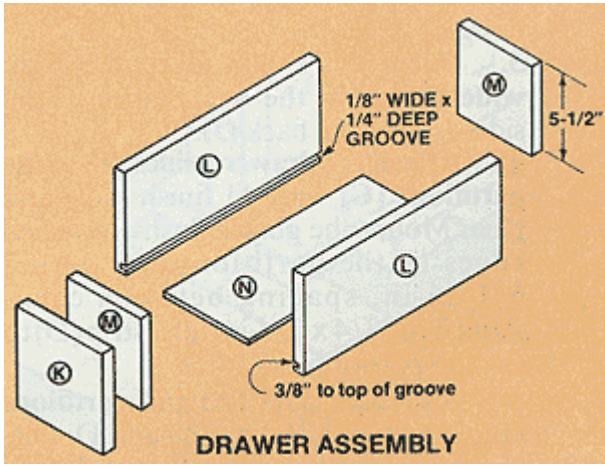
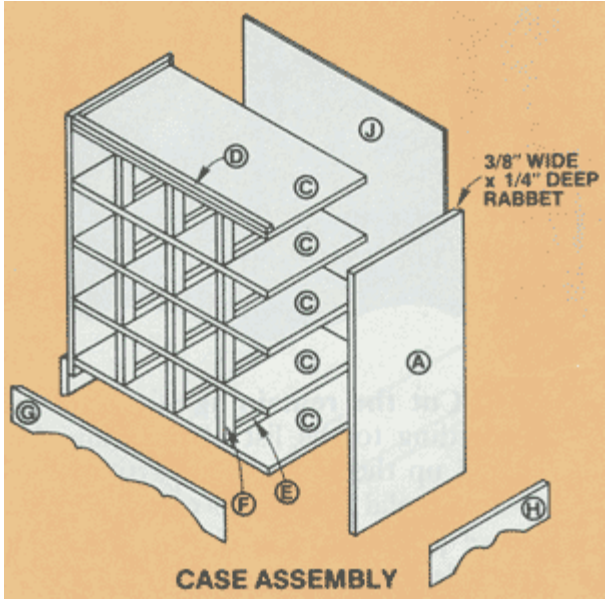

ADJUSTABLE DESKTOP BOOKSHELF



This clever, adjustable shelf is perfect for keeping reference books handy on the desktop, kitchen counter or workbench...and it's fast and easy-to-build, as well. We used oak for our example, but any attractive hardwood such as maple, cherry or walnut will be equally attractive and salable.

Begin by cutting all pieces to size, according to the drawings. Cut a centered, 1-15/16" high x 1-1/2" wide "tongue" on the bottom of each bookend. Use your bandsaw or scroll saw to cut a 1-15/16" wide x 3/8" deep notch in one face of each brace, as shown in the drawings. Rough out the curves for the bookends and feet using your bandsaw, scroll saw or saber saw, then smooth them with a 2-1/4" Drum Sander and 1-1/2" Drum Sander.

TIP: For added production speed, you may choose to temporarily stack the ends and feet in pairs using double-stick tape for sawing and sanding.

Glue the two stretchers to the spacers, clamp them together and set aside to dry. Glue and clamp the feet onto the ends of the stretchers as shown and set aside to dry. Sand the top and ends of this assembly.

Insert the adjustable bookends and glue the braces into place. Be careful to allow about 1/32" of clearance to allow easy operation. Stain and seal with a finish of your choice.

LIST OF MATERIALS

(finished dimensions in inches)

Feet (2)	3/4 x 1-1/2 x 10-1/2
Stretchers (2)	3/4 x 3 x 18
Spacers (2)	3/4 x 3/4 x 2
Braces (2)	3/4 x 3/4 x 4
Bookends (2)	3/4 x 5 x 6-1/2

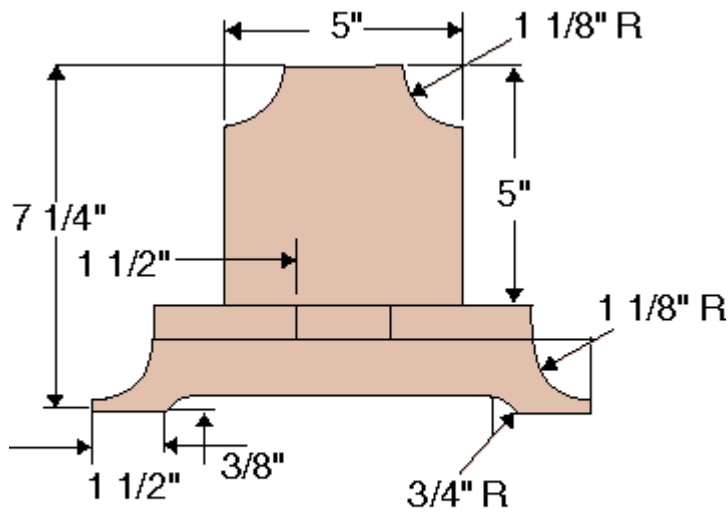
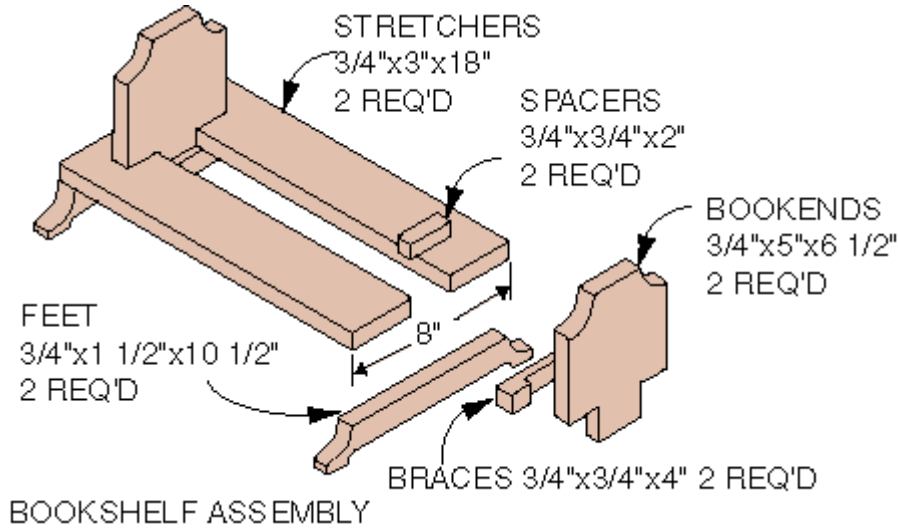

BOOKSHELF
 LAYOUT

KEYED CORNER JEWELRY BOX



Whether simple or elaborate in design, jewelry boxes and *keepsake boxes* always make treasured gifts for family and friends. This particular box is made from highly figured woods using some unique construction techniques, including corners with *keyed* accents that give it a one-of-a-kind look.

Getting started

Begin by making your wood selection. You won't need much, so you could actually make this box from scraps you already have laying around the shop. We made ours from quarter-sawn red oak, walnut and spalted beach, but with the wide variety of unique, exotic woods available today through a host of reputable suppliers, your options are virtually limitless.

Sides and Ends

Rough cut some 3/4" stock for the Sides (A) and Ends (B) to approximately 3-1/2" x 29", then plane your stock down to 1/2" using your Thickness Planer. Once you've attained the desired 1/2" thickness, joint one edge, then rip and joint the opposing edge to a finished width of 3-3/16".

Next, tilt your saw table to 45-degrees, then cut and miter the Sides (A) and Ends (B) to length, as per the Bill of Materials.

Using your Dado Set-Up, Shoppersmith Router Package or Shoppersmith Pro Fence System Router Table with a 1/4" Straight Router Bit, cut 1/4" wide by slightly deeper than 1/4" grooves in these pieces that will accept the boxTop and Bottom.



TIP: Have a 1/4" wide test groove cut in a piece of scrap wood for use in checking the fit of the Bottom (C) and assembled Top pieces as you bring them to the required thickness in the following step.

Top and Bottom

Rough cut two pieces of stock for the Bottom (C) and inside Top (D) from 3/4" stock to approximately 5" x 8-1/2". Next, resaw another piece of (approx.) 5" x 8-1/2" stock to a 1/8" thickness, then run it through your Planer to attain a 1/16" thickness for the Outside Top (E).

Tip: If you can't find a large enough piece of "accent" wood for the Outside Top (E), you can always resaw a small piece into a series of 1/8" thick pieces. Then arrange them into an interesting pattern and glue them together with the aid of masking tape and rubber bands. Lay a weight of some sort on top to keep them flat while they dry overnight. Allow to dry for 24 hours.

Thickness plane the Bottom (C) to 1/4" and the Inside Top (D) to slightly over 3/16". Leave both pieces oversized for now.

Using double-stick carpet tape, attach the good face of your Outside Top (E) to a flat piece of plywood, then thin them down to the required 1/16" thickness using your Belt Sander or a hand plane.

IMPORTANT: Do NOT use our high adhesion Double-Stick Tape for this task, as it will create too tight of a bond to allow for easy removal of the thin Top piece from the plywood after planing without breakage.

Next, laminate (glue and clamp) the Outside Top (E) to the Inside Top (D). Once the glue has dried completely, cut the assembled Top (D & E) and Bottom (C) to their finished size of 4-1/2" x 7-1/2". Run the Top through your Thickness Planer -- with the Inside Top (D) up -- and plane it to the required 1/4" thickness.

Assembly of the Basic Box

Finish sand all inside surfaces of the box and dry fit them together. If everything fits properly, apply a small amount of glue to the mitered corners of the sides (A) and ends (B) and clamp them together. Be sure to use only a small amount of glue and wipe away any excess immediately with a cloth. You'll make a series of saw cuts later to separate the Top of the Box from the Bottom.



Allow the completed box assembly to dry thoroughly for 24 hours, then sand it lightly. It's best to hand sand the Box at this stage to avoid removing too much stock.

Forming the *Keyed* joints with a special Jig

Building and using the special *Keyed* Joint Jig shown here will add strength and "class" to your finished Box. When the Jig is used in conjunction with a 1/4" Dado Blade, you'll get the correct width groove with a flat bottom.

NOTE: You could also use the Shoptsmith Router Table Kit with a 1/4" Straight Router Bit to perform this operation.

Be sure to allow an extra 3/16" between the top and middle *Keys*, since this will be removed when you cut the Box assembly apart later to form the Lid.

Thickness plane the dark accent stock (walnut in our case) that you'll use to create the 1/4" *Keys* (J) so they'll fit snugly in the 1/4" grooves you cut for them, above. Cut your *Keys* off of your stock at a 45-degree angle, then use your Drum Sander to form a slight concave "dish" on one edge of each *Key* to provide a little extra glue space.

Glue the *Keys* into their slots. Once they've dried completely (12 hours or so), use your Table Saw or Bandsaw to carefully saw off the excess *Key* stock. Finally, use your Belt Sander to sand the *Keys* flush with the Box surfaces.

Separating the Lid from the Box

Using your Table saw with a blade that takes an approximate 1/8" kerf (Shoptsmith's 10" Carbide Tipped Combination Blade or Hollow Ground Blade will work nicely for this job), cut off the Box Lid by guiding the assembled Box against your Rip Fence. Set your blade's depth-of-cut to slightly more than the thickness of your stock. See the drawing for the exact dimensions of where to make these cuts.

Base Assembly

The Base Assembly is made from 3/4" x 3/4" dark accent stock (in our case, Walnut). First, cut your Base Sides (F) and Base Ends (G) to size, per the Bill of Materials. Next, miter their corners to a 45-degree angle, test-fitting as you go to be sure the Base Assembly fits properly around the assembled Box Bottom.



Next, use your Bandsaw or Scroll Saw to cut out the recessed areas between the Feet as shown in the drawings. If necessary, use a small Drum Sander to smooth these recessed areas prior to assembly.

Finally, use a hand plane or a Router Table with a Chamfering Bit to chamfer the outside top edges of the Base Sides and Ends.

Tray and Supports

Cut the Tray (H) and Tray Supports (I) to size per the Bill of Materials. Glue the Tray Supports in position and secure them with spring clamps or small Handscrews until they dry thoroughly.

Use the Shoppersmith Router Package with a 1/4" Router Chuck and a "3-in-1 Router Bit" to form the recess in the bottom of the Tray, as shown in the drawing.

Final steps and finishing

Hand sand all completed pieces of the box to a smooth finish, then use a sharp chisel to hand cut the mortises for the hinges.

Carefully glue the Base Assembly together around the Box Bottom. A band-type Framing Clamp will make easy work of this job.

Once everything has dried thoroughly, apply the finish of your choice.

Using double-stick carpet tape, attach the good face of your Outside Top (E) to a flat piece of plywood, then thin them down to the required 1/16" thickness using your Belt Sander or a hand plane.

IMPORTANT: Do NOT use our high adhesion Double-Stick Tape for this task, as it will create too tight of a bond to allow for easy removal of the thin Top piece from the plywood after planing without breakage.

Next, laminate (glue and clamp) the Outside Top (E) to the Inside Top (D). Once the glue has dried completely, cut the assembled Top (D & E) and Bottom (C) to their finished size of 4-1/2" x 7-1/2". Run the Top through your Thickness Planer -- with the Inside Top (D) up -- and plane it to the required 1/4" thickness.

Assembly of the Basic Box

Finish sand all inside surfaces of the box and dry fit them together. If everything fits properly, apply a small amount of glue to the mitered corners



of the sides (A) and ends (B) and clamp them together. Be sure to use only a small amount of glue and wipe away any excess immediately with a cloth. You'll make a series of saw cuts later to separate the Top of the Box from the Bottom.

Allow the completed box assembly to dry thoroughly for 24 hours, then sand it lightly. It's best to hand sand the Box at this stage to avoid removing too much stock.

Forming the *Keyed* joints with a special Jig

Building and using the special *Keyed* Joint Jig shown here will add strength and "class" to your finished Box. When the Jig is used in conjunction with a 1/4" Dado Blade, you'll get the correct width groove with a flat bottom.

NOTE: You could also use the Shopsmith Router Table Kit with a 1/4" Straight Router Bit to perform this operation.

Be sure to allow an extra 3/16" between the top and middle *Keys*, since this will be removed when you cut the Box assembly apart later to form the Lid.

Thickness plane the dark accent stock (walnut in our case) that you'll use to create the 1/4" *Keys* (J) so they'll fit snugly in the 1/4" grooves you cut for them, above. Cut your *Keys* off of your stock at a 45-degree angle, then use your Drum Sander to form a slight concave "dish" on one edge of each *Key* to provide a little extra glue space.

Glue the *Keys* into their slots. Once they've dried completely (12 hours or so), use your Table Saw or Bandsaw to carefully saw off the excess *Key* stock. Finally, use your Belt Sander to sand the *Keys* flush with the Box surfaces.

Separating the Lid from the Box

Using your Table saw with a blade that takes an approximate 1/8" kerf (Shopsmith's 10" Carbide Tipped Combination Blade or Hollow Ground Blade will work nicely for this job), cut off the Box Lid by guiding the assembled Box against your Rip Fence. Set your blade's depth-of-cut to slightly more than the thickness of your stock. See the drawing for the exact dimensions of where to make these cuts.

Base Assembly

The Base Assembly is made from 3/4" x 3/4" dark accent stock (in our case, Walnut). First, cut your Base Sides (F) and Base Ends (G) to size, per the Bill of Materials. Next, miter their corners to a 45-degree angle, test-fitting as



you go to be sure the Base Assembly fits properly around the assembled Box Bottom.

Next, use your Bandsaw or Scroll Saw to cut out the recessed areas between the Feet as shown in the drawings. If necessary, use a small Drum Sander to smooth these recessed areas prior to assembly.

Finally, use a hand plane or a Router Table with a Chamfering Bit to chamfer the outside top edges of the Base Sides and Ends.

Tray and Supports

Cut the Tray (H) and Tray Supports (I) to size per the Bill of Materials. Glue the Tray Supports in position and secure them with spring clamps or small Handscrews until they dry thoroughly.

Use the Shoppersmith Router Package with a 1/4" Router Chuck and a "3-in-1 Router Bit" to form the recess in the bottom of the Tray, as shown in the drawing.

Final steps and finishing

Hand sand all completed pieces of the box to a smooth finish, then use a sharp chisel to hand cut the mortises for the hinges.

Carefully glue the Base Assembly together around the Box Bottom. A band-type Framing Clamp will make easy work of this job.

Once everything has dried thoroughly, apply the finish of your choice.

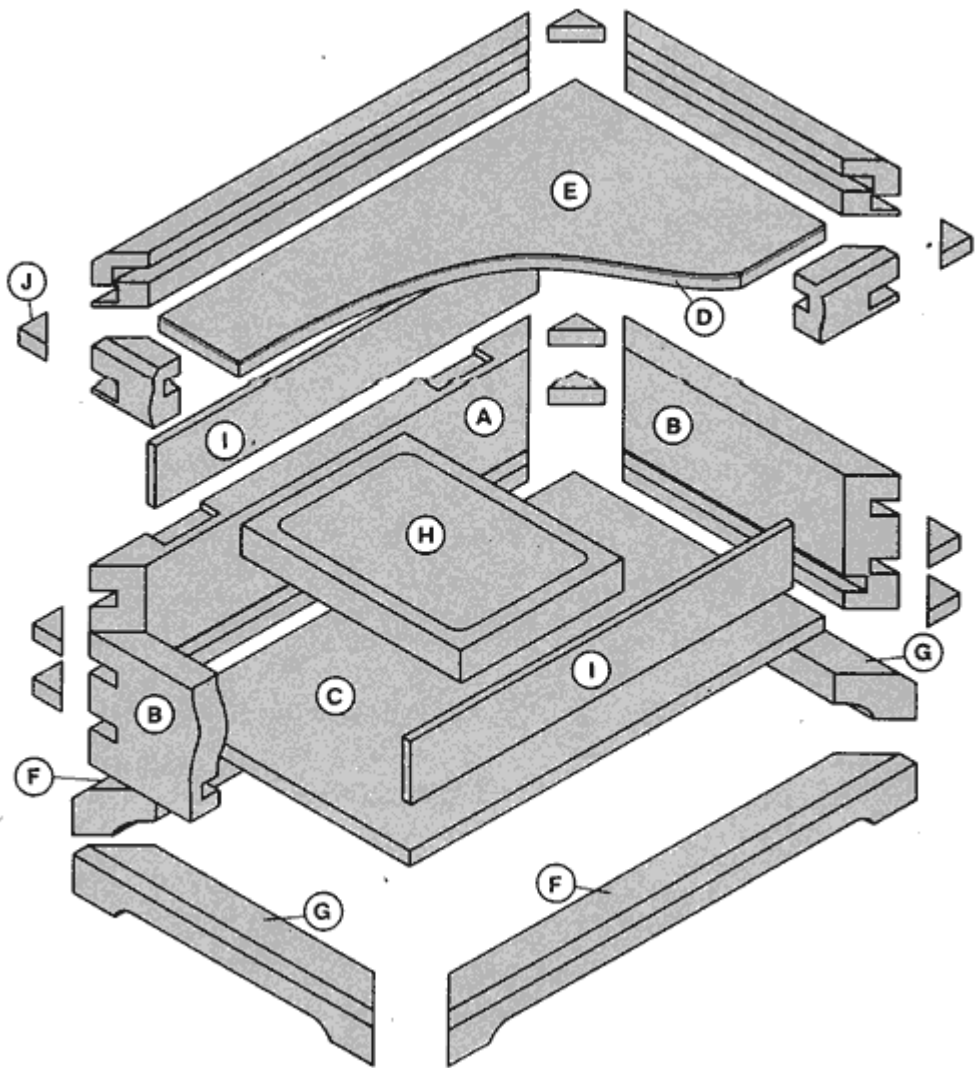

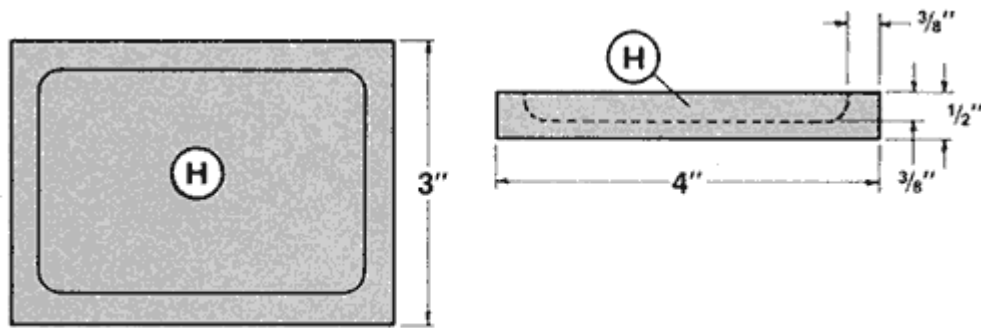
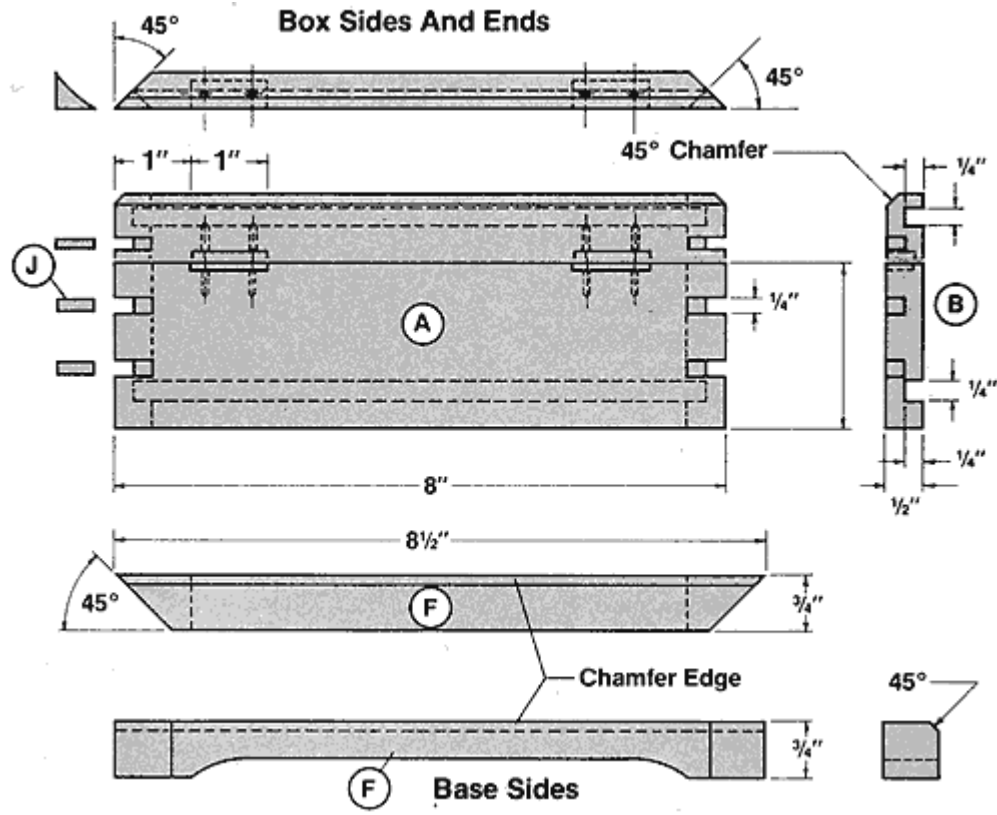

Tray Diagram

(All pieces $\frac{3}{4}$ " plywood)

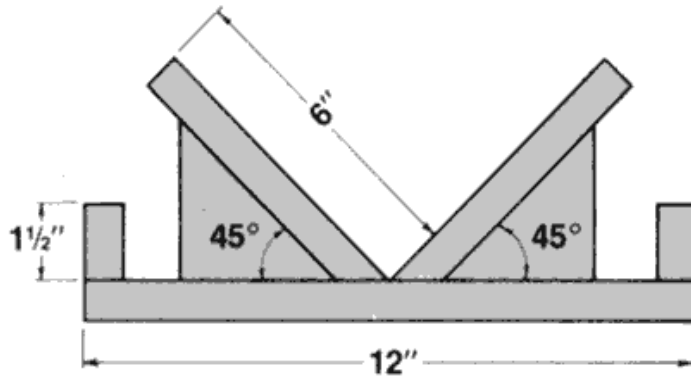

(Side View)

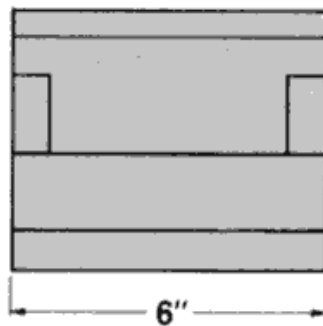

(End View)

Use jig in conjunction with rip fence. Jig cradles box to cut kerfs.

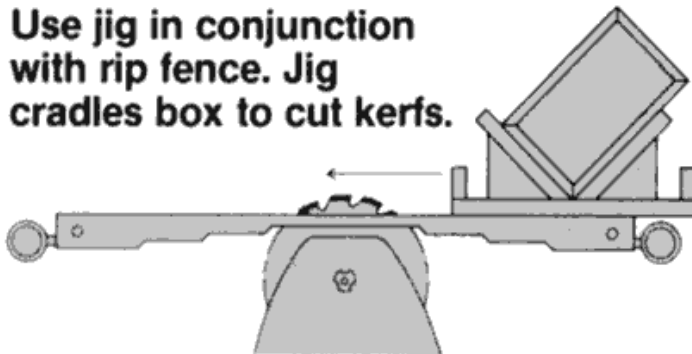

WARNING: Use of this jig requires the removal of the upper saw guard. Work with extreme caution.



LIST OF MATERIALS

(finished dimensions in inches)

The Pieces		
A	Sides (2)	1/2 x 3-3/16 x 8 (oak)
B	Ends (2)	1/2 x 3-3/16 x 5 (oak)
C	Bottom	1/4 x 4-1/2 x 7-1/2 (oak)
D	Inside Top	3/16 x 4-1/2 x 7-1/2 (oak)
E	Outside Top	1/16 x 4-1/2 x 7-1/2 (spalted beech)
F	Base Sides (2)	3/4 x 3/4 x 8-1/2 (walnut)
G	Base Ends (2)	3/4 x 3/4 x 5-1/2 (walnut)
H	Tray	1/2 x 3 x 4 (walnut)
I	Tray Supports (2)	1/8 x 1 x 7 (oak)
J	Keys (12)	1/4 x 3/4 x 1 (walnut)

Hardware

(2) 1" x 3/4" Solid Brass Hinges

COLONIAL SPICE CABINET



Here's a simple project, featuring quick and easy butt, rabbet and dado joints that let you cut out the various components and put them together in a flash. We made ours from knotty pine, but it would look - and sell - even better (and for more money) if it was made from cherry or oak.

A COUPLE OF VALUABLE TIPS:

TIP #1: These Cabinets could easily be made in different styles by merely altering the shape of the Back (B) and the Sides (A). For example, a straight top and bottom on the Back with straight Sides (instead of curves at the top and bottom) will produce a more contemporary style.

Changing the Knobs from porcelain to a more contemporary style is yet another way to easily produce another variable on this Cabinet.

TIP #2: Considerable time can be saved by *Stack* or *Pad-Cutting* the profiles at the top and bottom of the Backs (B) and Sides (A). Once you've thickened these pieces and cut them to the proper size on your Table Saw, merely attach a stack of up to four of them together with our High-Adhesion,



Double-Stick Tape ...then cut out the profiles on all four at once, using your Scroll Saw or Bandsaw.

This same procedure could be used for drilling the Mounting Holes in the Backs and the Knob Mounting Holes in the Drawer Fronts.

Resaw a 5-foot piece of 1" x 4" stock, using your bandsaw for the 1/4" and 3/8" thick pieces (J, K, L, M & N). Set up your cuts so you end up with 9/32" and 13/32" stock that you'll then run through your planer to arrive at the 1/4" and 3/8" thicknesses.

Plane a 4-foot length of 1" x 10" - and a 7-foot length of 1" x 4" to a thickness of 1/2".

Cut the Back (B) from the 1" x 10" stock. Then rip the prepared 1/4" stock to 3-1/8" for the Drawer Backs (K & L) and Drawer Bottoms (M & N). Next, rip the Sides (A) to 4". Do not rip the Back (B) to finished width, yet.

Cut all parts to length, according to the Bill of Materials.

Rip the 1/2" wide x 1/4" deep rabbets in the backs of the sides (A) using your Dado set-up and a wooden, shop-made auxiliary fence to keep from cutting into the face of your Rip Fence (See Detail A). Use a Feather Board and a Push Block to keep your hands out of harm's way when making these cuts.

Next, re-adjust your Rip Fence and your Blade's depth-of-cut to form the 3/8" wide x 1/4" deep rabbets in the Drawer Fronts (G & H) using the same Fence attachment and a shop-made wooden Miter Gauge face for support (See Fig. 1). Be sure to make these cuts slowly to prevent chip-out on the exit side of your cuts.

Adjust your Dado Blade to 1/4" and use your Rip Fence to guide your stock as you cut the 1/8" deep grooves in the Drawer Sides (J) and Fronts (G & H) to accept the Drawer Bottoms. Again, use a Push Block for safety.

Remove your Rip Fence and cut the dadoes in the sides (A) and partitions (C & F).

NOTE: As an option, you could also use a router with a straight router bit of the appropriate width to perform this or any of the previous rabbeting, dadoing or grooving operations.

Cut out the Side (A) contours using your Bandsaw or Scroll Saw . Then, use a small Drum Sander to smooth the curved areas.



Dry assemble the Sides (A) and parts (C, D, E & F) with clamps and check for fit. Disassemble and then use glue and small brads on the outside joints...and glue only on the interior joints.

NOTE: Be sure to check all joints for squareness before leaving the glued Cabinets to set-up thoroughly.

Rip the Back (B) to width, then cut and sand the top and bottom contours. Drill the 1/4" mounting hole and attach the Back to the Sides (A) with 3/4" brads.

Drill the Knob mounting holes in the Drawer Fronts (G & H).

Assemble the Drawers with glue and 3/4" brads. Once the glue has dried completely, use your Belt Sander to sand each Drawer. to fit perfectly in its "cubbyhole". Be sure to number each Drawer on the back or bottom to indicate which Drawer fits in which location.

Finish sand the entire Cabinet and round all the edges slightly to achieve a well-worn, Colonial effect. Apply stain if desired, followed by a finish coat of satin polyurethane or similar material. Install the Drawer Knobs.

LIST OF MATERIALS **(finished dimensions in inches)**

A	Sides (2)	1/2 x 4 x 20
B	Back	1/2 x 8-1/2 x 24-3/4
C	Horizontal Partitions (2)	1/2 x 3-1/2 x 8-1/4
D	Bottom	1/2 x 3-1/2 x 8-1/4
E	Center Drawer Partitions (4)	1/2 x 3-1/2 x 4
F	Vertical Partition	1/2 x 3-1/2 x 11-3/4
G	Small Drawer Fronts (6)	1/2 x 3-1/2 x 3-3/4

DETAIL A

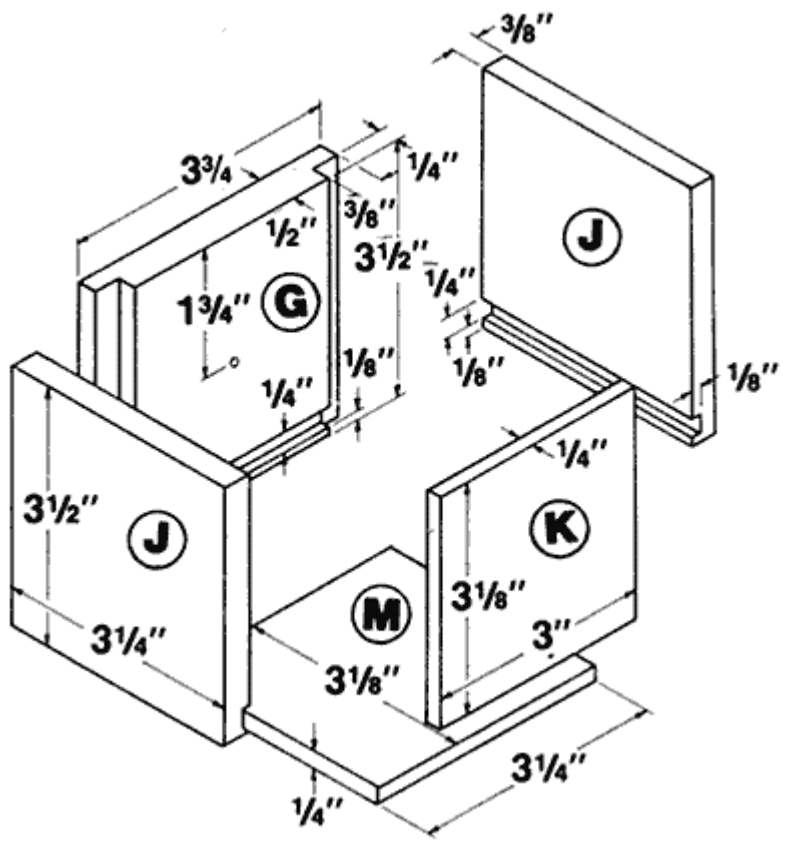
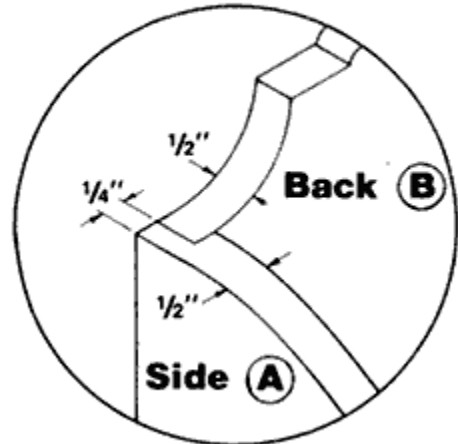

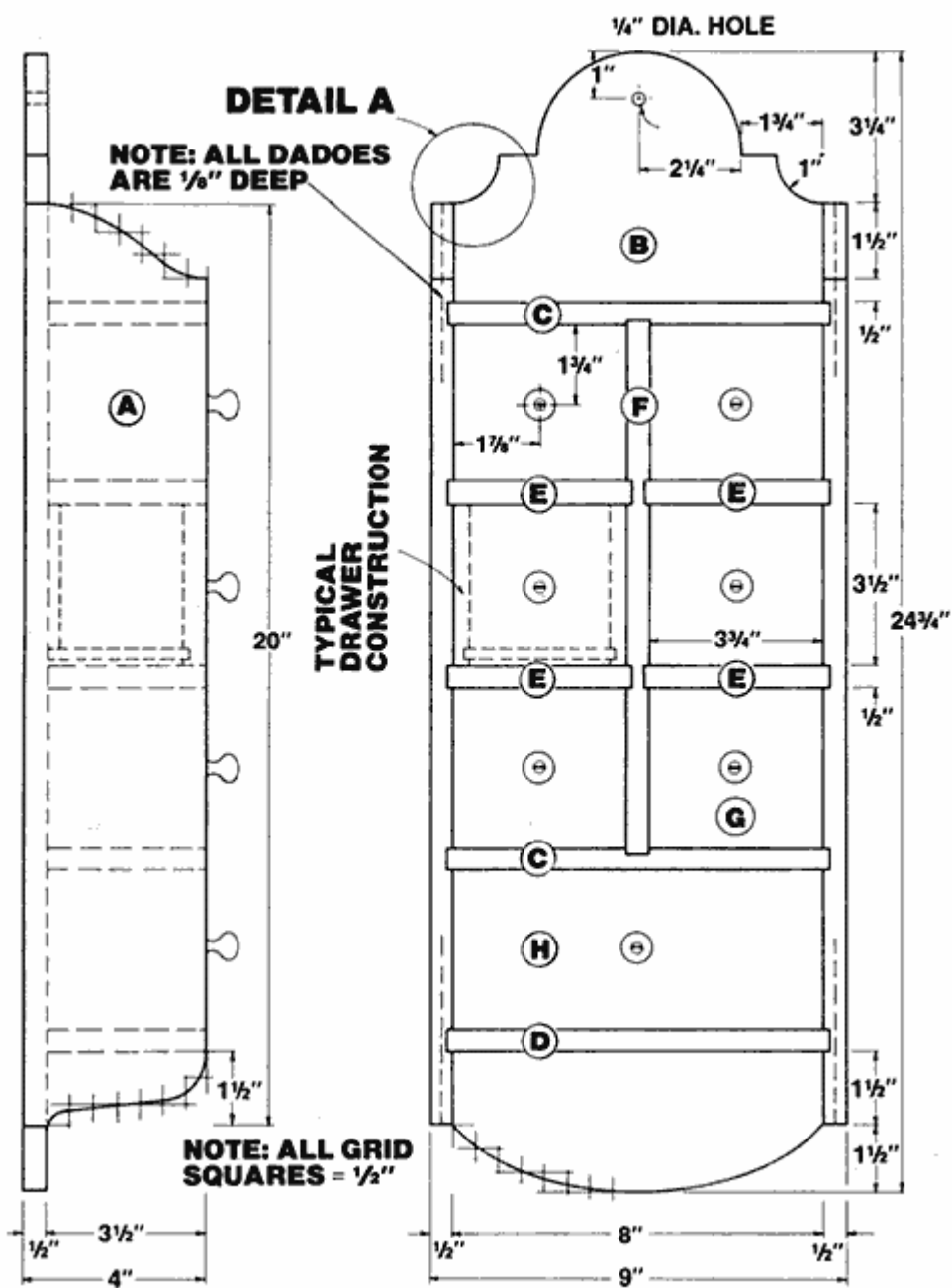

THE WALL HUNG CURIO CABINET

AA classic-styled, 4-shelf cabinet for any room in the house



Have you ever noticed that some projects require only a few hours of your time to complete, while others seem to go on for ever and ever? So, why is that? Part of the answer to this question can be found in the care with which the project is approached. If you start a project thinking about how many tedious steps are going to be involved in bringing it to completion, chances are, it is indeed going to seem like a tedious, drawn-out project.

On the other hand, if you try to think of each board as an individual project of its own, then everything will progress more quickly. By following this approach, the hours you spend on a project will, instead, represent the putting together of many smaller projects. As a result, you'll be finished before you know it, and your results will be far more appealing.

The Wall-Hung Cabinet is the perfect project for teaching yourself this valuable lesson. While you could decide to spend a single evening building a simple cutting board or trivet, if you devote the same amount of time to carefully cutting out some of the pieces for a more complex project such as this Cabinet, when you've finished, you'll have a lot more to be proud of. So, slow down, enjoy the wood, measure everything very carefully ("Measure Twice - Cut Once"), don't get in a hurry, then reap the rewards of your efforts!

Important Design Note: Our cabinet features a Colonial style, dictated by the curved bottom face frame rail (F), the curves in the bottoms of the two sides (A) and the curves in the front and side top moldings (J & K). For a more contemporary or modified Mission style, leave the rail and side pieces straight and alter the top molding to create a series of stepped, 45-degree beveled edges.



1. Take whatever time you need to select high-quality, properly cured, straight wood for this project. Although we built our Cabinet using some highly figured cherry -- oak, walnut, maple or even some of the more striking exotics will also provide some great-looking results. Just keep in mind that top-quality stock will result in a better appearance and fewer problems as you move step-by-step through the project.

Use the best pieces for the sides, face frame and door stiles and rails, making your selections on the basis of grain configuration, as well as the quality of the wood you're using. For example, if you've chosen to use cherry, you wouldn't want to make the left side face frame from a highly figured piece of stock and the right side from a straight-grained piece. Think carefully about how each component will look when the entire project is assembled.

2. Start by ripping all stock to the proper widths, according to the List of Materials. Always remember to begin by using your Jointer to first smooth one edge of your stock....then rip it to width plus 1/32" on your table saw...then joint the opposing edge, removing the extra 1/32".

3. Crosscut all of your stock to length...**except** for the door stiles and rails (G & H) and the front and side moldings (J & K). You'll cut these in step 9. When crosscutting, be sure to allow an extra 1/8" of length for careful trimming later.

TIP: If you're working with extremely long pieces of stock, the Shoppersmith Support Table or Roller Stand will help you achieve added support and improved results when ripping - while the Miter Gauge Extension Face or a Cross-Cut Sliding Table will be very helpful during crosscutting operations.

4. Next, crosscut the cabinet sides (A) to final length and mark the locations of the rabbets and dados. Transfer the contours for the bottoms of the sides to your stock.

5. To form the rabbets for the back, change to a Dado Blade set-up and attach a wooden auxiliary fence such as the one shown here to your Rip Fence to avoid cutting into the Rip Fence Face.

Using this set-up, cut the 3/8" x 3/8" rabbets on the sides (A) and top (B). Be sure to use a Push Block to keep your hands out of harm's way.

Remove the Fence and cut the dados in the sides (A) for the bottom and shelves (C), then form the rabbets on the ends of the sides for the top.



NOTE: If you don't have a Dado set-up, you could also cut the rabbets by making two passes with an ordinary blade on your Table Saw...or with the Shopsmith Router Package or Router Table Kit.

6. Use your Bandsaw, Scroll Saw or hand-held saber saw to cut the contours on the bottoms of the sides (A). Tip: When doing this, be sure to cut outside your marked line so you can sand your contours down to perfection using your Drum Sander.

7. Assemble the cabinet case (sides [A], top [B], bottom and shelves [C]) with woodworker's glue and #8 x 1" flathead wood screws or 6d finishing nails. If you're using nails, be sure to set and fill over the heads. If you're using screws, don't forget to drill counterbores for the heads and fill over them with glued-in screw plugs.

8. The face frame pieces (D, E & F) are cut to fit. Starting with the stiles (D), mark and cut them to length, leaving the lines...then disc sand them to exact length.

Next, measure the exact width of your assembled case and subtract the exact widths of your stiles (D) to calculate the correct length for the rails (E & F). Cut and sand the rails to length.

Now, use your Bandsaw or Scroll Saw to cut the curves in the bottom face frame rail (F). Again, be sure to cut outside your marked line so you can sand your contours using your Drum Sander.

Mark the locations for the dowel holes in the ends of the rails and the edges of the stiles and drill them using your MARK V in Horizontal Boring mode. Glue and assemble the face frame. Once the glue has dried completely, attach the frame to the assembled case with glue and #8 x 1-1/2" screws or 6d finishing nails. Set & fill the nail heads or counterbore and plug the screw heads as in step 7, above.

9. The door frames for this cabinet can be made with any of the following: Your Shopsmith Shaping Package with the Complete Cabinet Set cutters. Your Shopsmith Molding Package with the matching, mirror-image 3/16" Cove & Bead Cutter and 3/16" Bead & Cove Cutter.

The actual length of the rails will depend on the cutter you use. Whichever cutter you decide to use, be sure to form the ends of the rails first, then mold or shape the edges of the stiles and rails. **IMPORTANT:** Be sure to use scrap pieces for testing your set-ups before cutting your actual pieces



Assemble the frames with glue and check carefully for absolute squareness before setting them aside to dry.

10. Sand the entire project. Start with 80-grit paper and work your way through progressively finer grits until you get to 220-grit paper. Round off all edges slightly to prevent any splintering.

11. Cut the 3/8" plywood back to exact size and apply a stain or matching hardwood veneer to its inside face. Attach the back to the assembled frame using 4d nails or small brads. **Do not glue**

12. Use your Shoptsmith Molding Package and the three cutters shown in the "MOLDING DETAIL" illustration to form the molding for the top on a single, long piece of stock. Since this molding projects 45-degrees from the cabinet surface, it can be mitered on the MARK V by setting your Miter Gauge at 56-1/2 degrees and tilting the Worktable to 30 degrees. Be sure to hold the trim flat to the table and cut all three pieces to length from your single long piece. Again, take the actual measurements from your assembled cabinet to ensure the proper fit.

13. Mark the locations of the hinges and mortise the face frame and door frames with a chisel.

14. Apply the finish of your choice. Once the final coat has dried, install the glass in the doors and mount the doors to the cabinet

Side View:

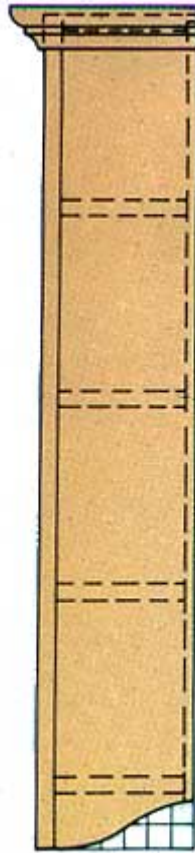

SIDE VIEW

Front View

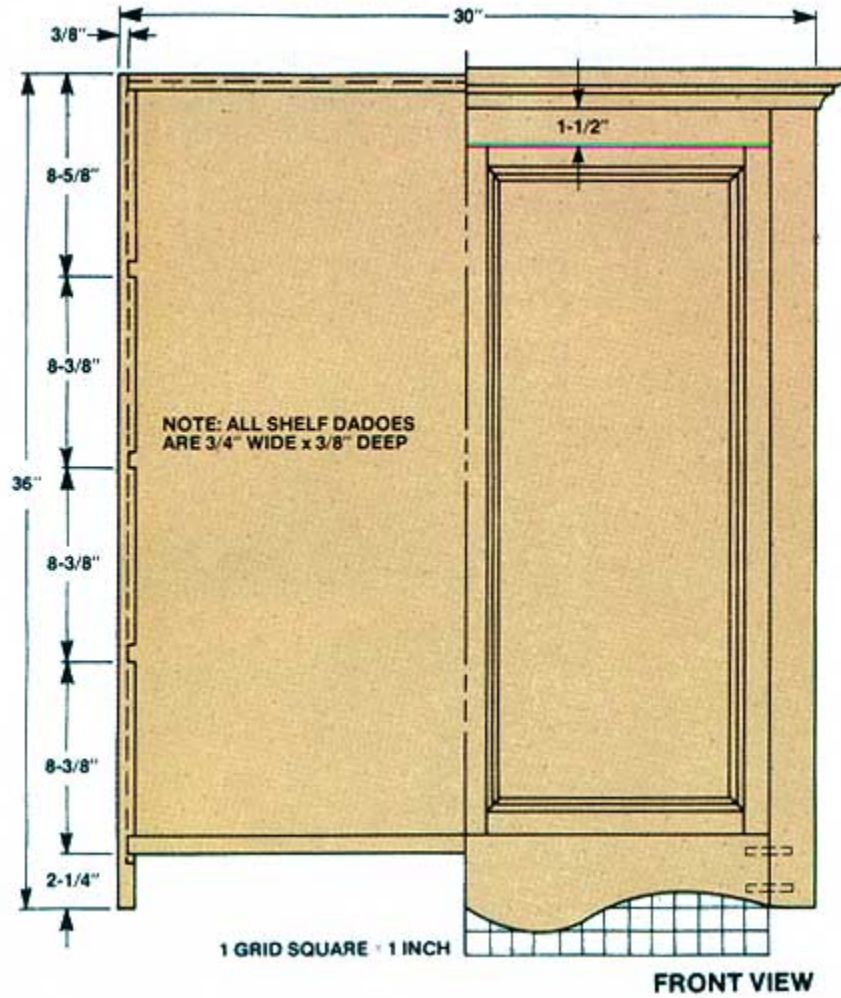

Door Assembly

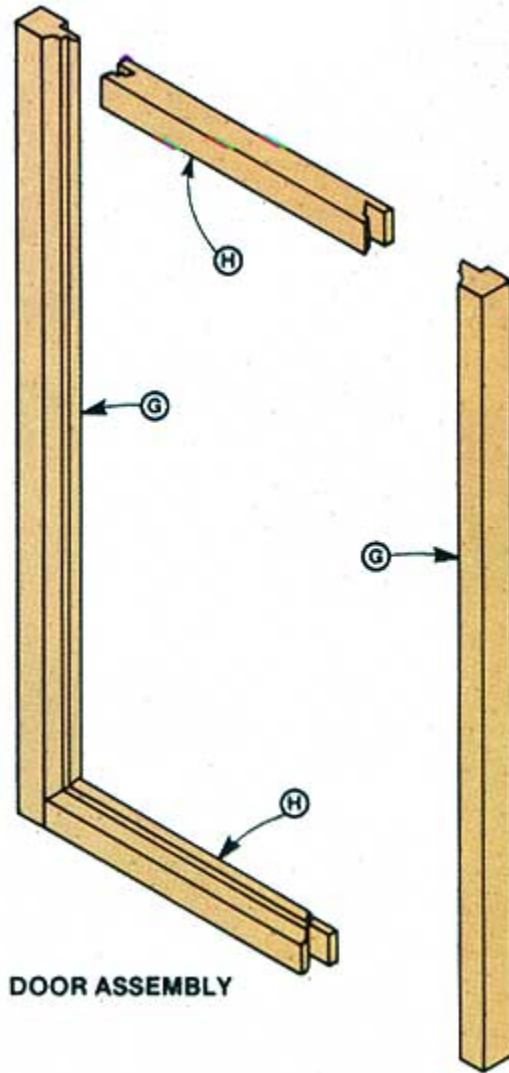

Case Assembly

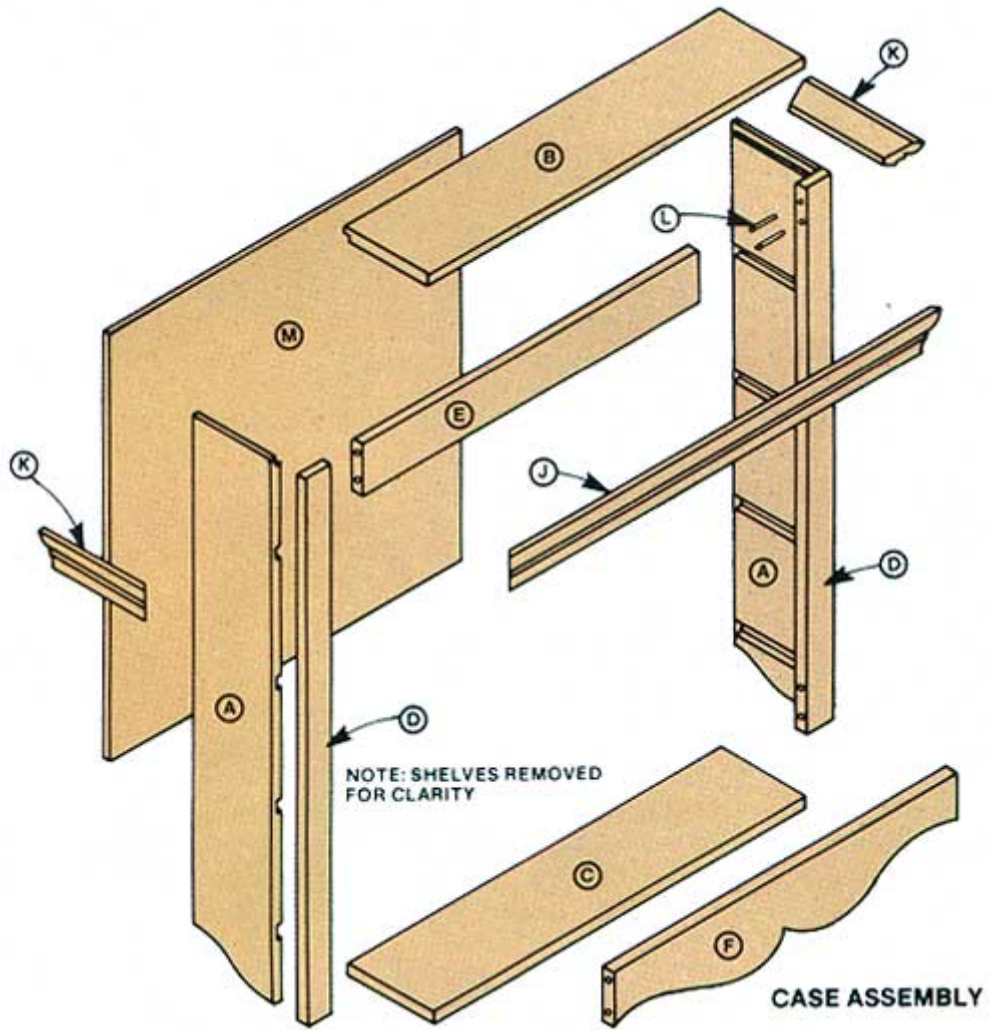

Door Frame Details

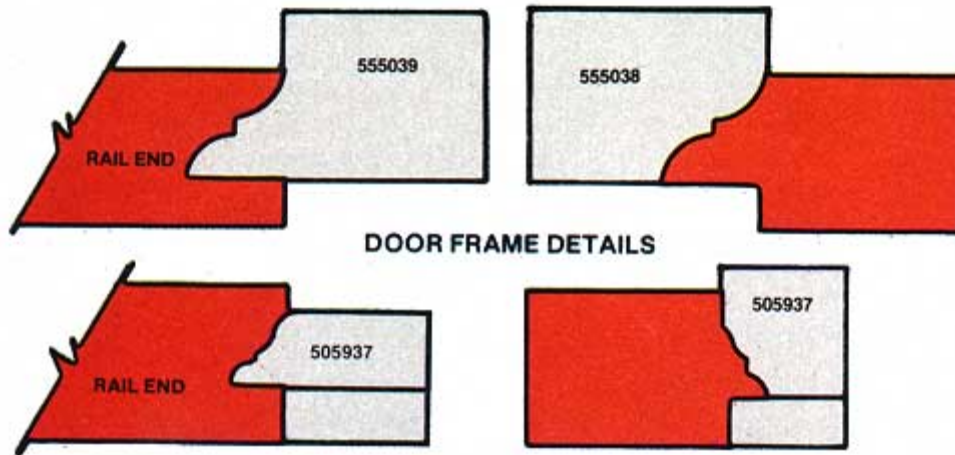

Molding Detail

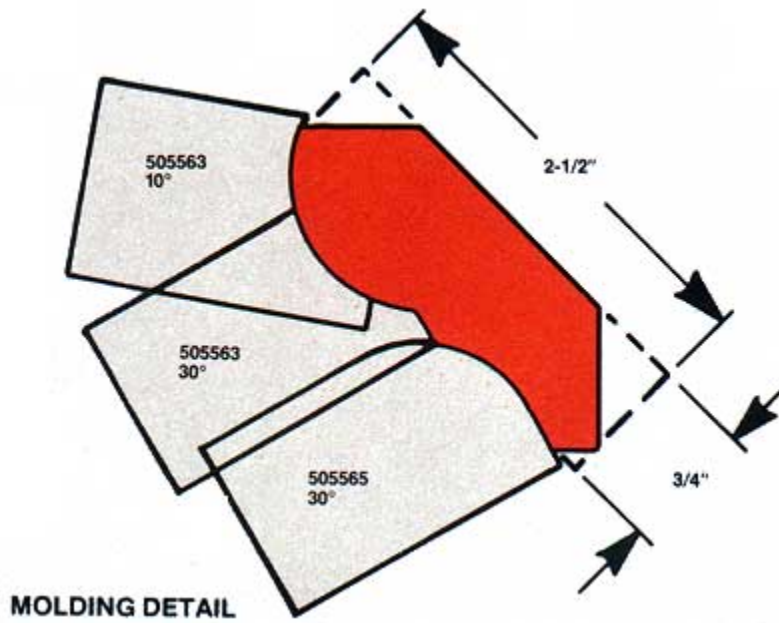

Bottom Back Corner Detail

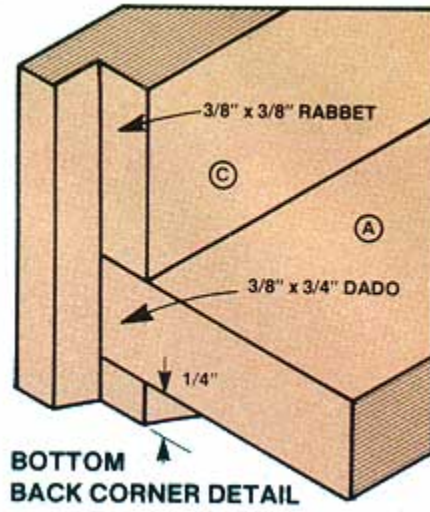

Top Back Corner Detail

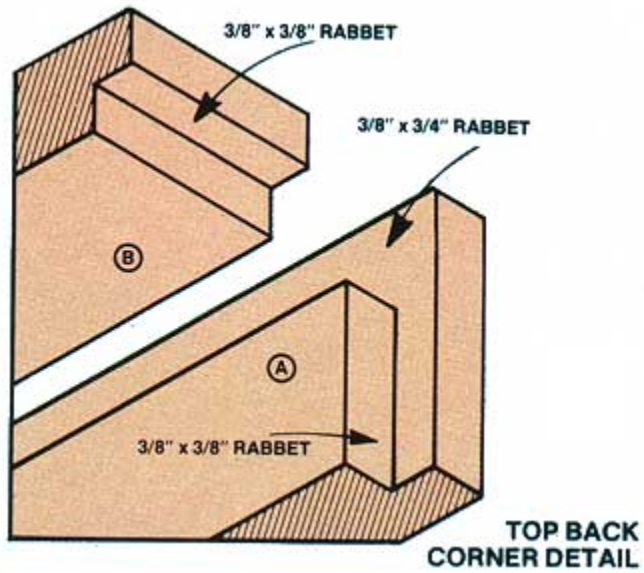



LIST OF MATERIALS

(finished dimensions in inches)

A	Sides (2)	3/4 x 6 x 36
B	Top	3/4 x 6 x 29-1/4
C	Bottom and Shelves (4)	3/4 x 5-5/8 x 29-1/4
D	Face Frame Stiles (2)	3/4 x 2 x 35
E	Top Face Frame Rail	3/4 x 3 x 26
F	Bottom Face Frame Rail	3/4 x 4-1/4 x 26
G	Door Stiles (4)	3/4 x 1-1/2 x 30
H	Door Rails (4)	1/4 x 1-1/2 x 11 (may vary with cutter used)
J	Front Molding	3/4 x 2-1/2 x 33
K	Side Molding (2)	3/4 x 2-1/2 x 8
L	Dowel Pins (8)	3/8 dia. x 2 long
M	Back	3/8 x 29-1/4 x 33-3/8

Hardware

Brass Door Hinges

Brass Door Knobs

#8 x 1-1/2" Wood Screws (or 6d Finishing Nails)

#8 x 1" Wood Screws (or 6d Finishing Nails)

Screw Hole Plugs

4d Finishing Nails (or Small Brads)

MOBILE POTTING TABLE

Make this move-around Potting Table in a single weekend and get set for a "blooming" Summer season!



If you have an active *Green Thumb*, you probably spend a fair amount of time potting and re-potting your treasured plants - and more likely than not, get your share of backaches from doing it! Now, you can put an end to those annoying backaches with this handy, 36" high Mobile Potting Table that we guarantee will make your chores lighter and put more "fun" back into your horticultural activities.

NOTE: Although we're calling it a Potting Table, by eliminating the cutout in the top, it also makes an excellent Barbecue Table, Poolside Porta-Bar or Move-Around Workbench.

With screwed and doweled construction, a beefy 1-1/2" thick top and solid, 4" x 4" legs, this Table is sturdy enough to handle your toughest tasks. Plus, the convenient Handle and Wheels bring added portability to this heavyweight *workhorse*.

We made our table from (mostly) ordinary 2"x4" fir construction lumber...being careful to pick out straight, knot-free pieces for the best appearance. Another option would be to make it from 3/4" thick Western Red Cedar, Redwood or Cypress stock, glued-up to the appropriate thicknesses. These alternative lumbers are much more durable when exposed to the weather.

We made our wheels from three pieces of 3/4" stock, glued-up to a 2-1/4" thickness, but you could just as easily purchase a couple of 8" diameter wheels and steel axle from your local Home Center. If you do decide to make your own, for the sake of durability, it will pay you to use a rugged, closed-



grain, hard wood such as maple...alternate the grain directions of the glued-up pieces for added strength...and round the edges over to help prevent splintering. For added protection, you could also cut out a couple of rings of motorcycle inner-tube and stretch them over your wooden wheels.

NOTE: Due to outdoor exposure, use only waterproof resorcinol or epoxy glue when assembling the Table.

CUTTING :

Begin by cutting the two Top Side Rails, two Top End Rails and two Top Support Rails to length, as per the Bill of Materials. Round over one end of each Top Side Rail using your Shoppersmith Bandsaw or Scroll Saw. Smooth the rounded ends with your MARK V Disc Sander.

Next, cut the two Shelf Side Rails, two Shelf End Rails, two Top Shelf Support Rails and four Legs to length, as per the Bill of Materials.

Cut Shelf to size and notch for the legs, as indicated. Now, cut a series of 48" long 2" x 4" strips for making the Top work surface. To be safe, cut nine pieces, 3-1/2" wide by 48" long...joint both opposing edges of each piece...then join them together using glue and dowels or biscuits. When dry, cut the Top to its finished size of 27-1/2" x 48" and use a saber saw or hand-held router to create the top cutout to fit a standard plastic tub of your choosing.

Cut out (6) 8-1/2" square x 3/4" thick pieces of stock for the wooden wheels. Glue them together and allow to dry. Using your Scroll Saw...or your Bandsaw with a Circle-Cutter, cut your Wheels to an 8" diameter.

Cut (16) 2" long pieces of 3/4" diameter dowel rod and (22) 5/8" long pieces of 5/8" diameter dowel rod (for lag screw plugs). Use an auxiliary, shop-made wooden Miter Gauge face and Shoppersmith's Miter Gauge Stop Rod to make quick work of cutting identical-length dowels. Round-over both ends of each 3/4" dowel and one end of each 5/8" dowel with your Disc Sander for easier insertion.

DRILLING:

Using your MARK V Drill Press set-up, drill blind, 1-1/4" diameter x 1-1/8" deep holes in the inside edges of the Top Side Rails to accept the 1/14" diameter Dowel Handle.

Drill (16) 3/4" diameter x 1-1/8" deep holes in the ends of the two bottom Shelf End Rails and Shelf Side Rails...and (16) matching 3/4" diameter x 1-



1/8" deep holes in the inside surfaces of the four legs for attaching the four Shelf Rails to the Legs, as shown in the drawing.

Drill (22) 5/8" diameter x 3/4" deep counterbores in the three Top Support Rails (not the center rail), Top Side Rails and Bottom Shelf Side Rails to accept the heads of the 1/4" Lag Screws (and the socket wrench required to tighten them).

Using the same Drill Press set-up, drill 1/4" diameter through-holes in these same locations for the Lag Screw shanks.

Drill 9/16" diameter through-holes in two of the legs to accept the 1/2" diameter wheel Axle (**NOTE:** If using store-bought wheels, this axle diameter may be different.)...then drill a 1/2" diameter hole in the center of each wheel.

PREPARING FOR ASSEMBLY

Next, temporarily dry-assemble (without glue) the Rails and Legs (not the top, shelf or axle/wheel assembly), using clamps. When you're comfortable that all components are properly positioned, insert an ordinary pencil into the 1/4" diameter lag screw holes to mark the positions of all pilot holes in the mating pieces. Before disassembling number all mating components to be sure everything goes back together as you have it. Disassemble and drill 1/8" diameter x 2" deep lag screw pilot holes in all mating components.

FINAL ASSEMBLY

Assemble and glue all frame components as shown in the drawing. Drop the Bottom Shelf into position and allow it to rest on the Bottom Rails without glue, nails or screws. This makes replacement easy, in the event of weather damage.

Attach the Top into position using three countersunk (**NOT counterbored**) #8 x 3" brass or stainless steel screws through the Top and into the top edge of each Side Rail and another into the center of each of the four Top Support Rails. **Do not glue the top to the frame.**

Thread each end of the Axle (1/2"-12 pitch) insert into Legs as shown and add wheels.

FINISHING

Stain and apply the weatherproof top coat of your choice. If you're using redwood or Western red cedar, a finish may not be necessary at all.



ADDED FUNCTIONALITY

If you like, you can add simple plumbing fixtures at the “tub” end of the Potting Table that hook up to your garden hose. That way, it could double as a vegetable clean-up table.

LIST OF MATERIAL

(finished dimensions in inches)

The Pieces	
Top (1)	1-1/2 x 27-1/2 x 48
Top End & Support Rails (4)	1-1/2 x 3-1/2 x 22-3/4
Top Side Rails (2)	1-1/2 x 3-1/2 x 52
Dowel Handle (1)	1-1/4 dia. x 25 long
Front Legs (2)	3-1/2 x 3-1/2 x 34-1/2
Rear Legs (2)	3-1/2 x 3-1/2 x 33-1/2
Bottom Shelf (1)	3/4 x 22-1/2 x 42-3/4 (exterior plywood)
Shelf End Rails (2)	1-1/2 x 3-1/2 x 15-3/4
Shelf Side Rails (2)	1-1/2 x 3-1/2 x 36
Shelf Support Rail (1)	1-1/2 x 3-1/2 x 19
Wheels (2)	8 dia. x 2 wide
Dowels (16)	3/4 dia. x 2 long
Dowel Plugs (22)	5/8 dia x 5/8 long

Hardware	
Steel Axle (1)	1/2 dia. x 28-3/4 long
Hex-Head Lag Screws (22)	1/4 dia. x 3 long
Brass or Stainless Wood Screws (10)	#8 x 3
Washers (8)	1/2 I.D. (for Axle)
Cap Nuts (2)	1/2 - 12 pitch

Assembly Plans

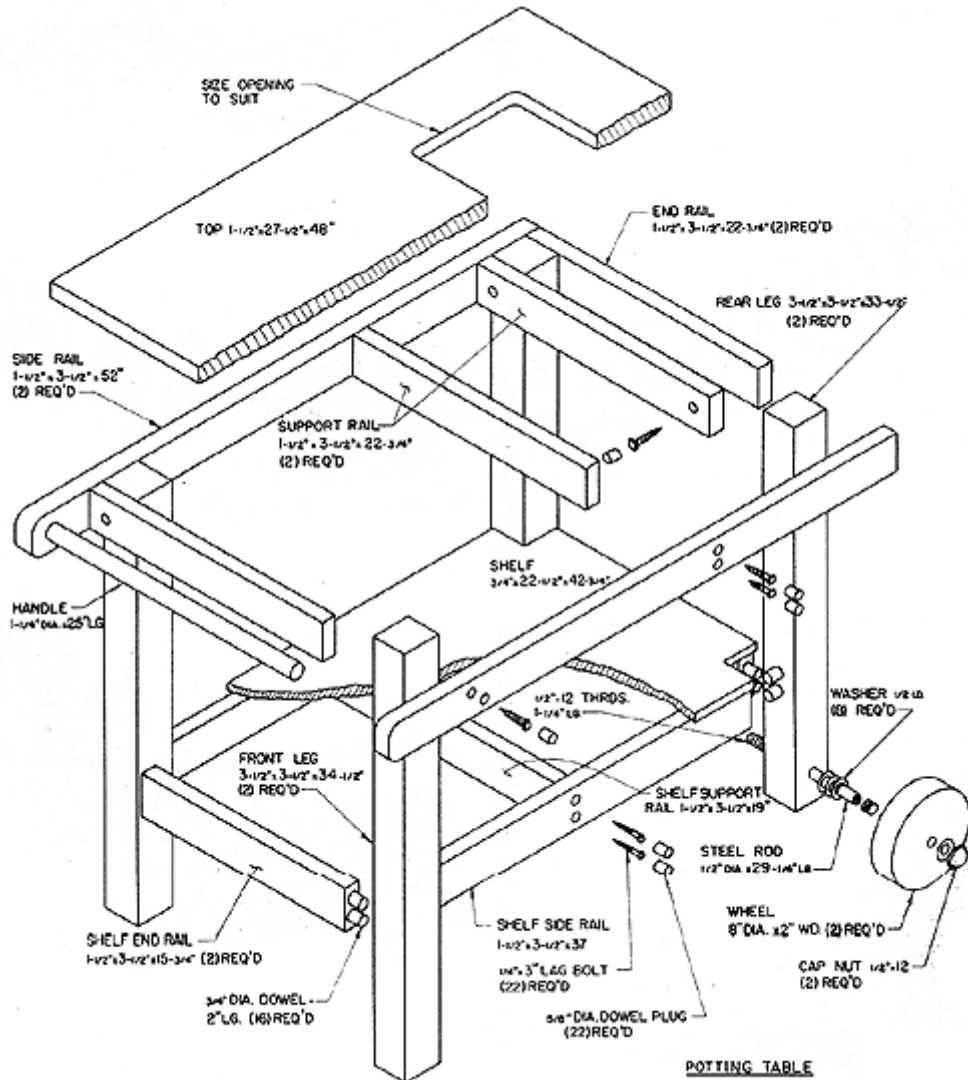

DRIED FLOWER VASE



The Dried Flower Vase was designed and turned by Rude (pronounced "Rudy") Osolnik, a master wood turner who was already retired from teaching generations of aspiring woodworkers at Berea College in central Kentucky when we met him and watched in awe as he originally created these two great projects for us in 1982.

Rude turned an amazing freeform bowl that now rests in Chicago's Museum of Science & Industry...and a laminated bowl that's part of the Smithsonian's permanent collection of fine woodworking projects by the top craftsmen from all over America.

According to Rude, "Working on the lathe is fun because it doesn't have to be bound by someone else's rules. Newcomers to the craft are realizing that they don't have to follow a textbook...and that once they've learned a few of the basics, it's a simple matter for each turner to develop his (or her) own style. It's a highly creative form of woodworking that you can start and finish on a single machine. Turn free-form and you don't even have to worry much about critical dimensions - just the overall design. The lathe leaves plenty of room for innovation and improvisation."

Our Dried Flower Vase was turned between centers, then separated from the scrap stock. However, you could just as easily use a Lathe Screw Center...or even a Lathe Chuck to facilitate faster workpiece mounting and removal.

This stunning little Dried Flower Vase is a true, free-form design that will look great with virtually any decor. We've included drawings for two different sizes and shapes, but your options here are limitless. Ours was turned from Eastern Red Cedar, but again, you can use any wood you like...even turn it from solid core plywoods (such as Baltic Birch) or woods laminated together from any combination of contrasting species you desire.



Start by mounting your stock between centers...on a conventional Faceplate...or even to a Screw Center, if you prefer. Depending on the intended finished shape of your Vase, you might elect to use an S-Shaped Tool Rest mounted in Shopsmith's Universal Lathe Tool Rest to ensure maximum chisel support, safety and working convenience during turning. Most of the work can be accomplished with an ordinary Gouge or Roundnose Chisel.

What about the Vase insides? Our example Vases feature either a 3/8" or 1/4" diameter hole bored down past the neck area for holding the Dried Flowers. If you prefer, they can also be hollowed-out to allow a small bundle of dried flowers to be displayed in a more "fanned-out" fashion. If you're using this approach, you may want to look into getting a small set of specialized Hollow-Forming Chisels for this purpose. However, it's important to remember that the single drilled hole approach requires far less time to complete...and therefore a considerably higher profit margin than the hollowed-out version.

About the only real design consideration for Vases such as these is that their necks be slender. If you're using "old" or scrap wood, let it show its age and imperfections. This just gives the Vase more "character". And, since the Vases are designed to hold dried flowers (requiring no water), there is no need for any special finishing operations. In fact, just a quick coat of furniture paste wax may be all that's required.

Suggested retail price: \$20 to \$30

Vase Plans

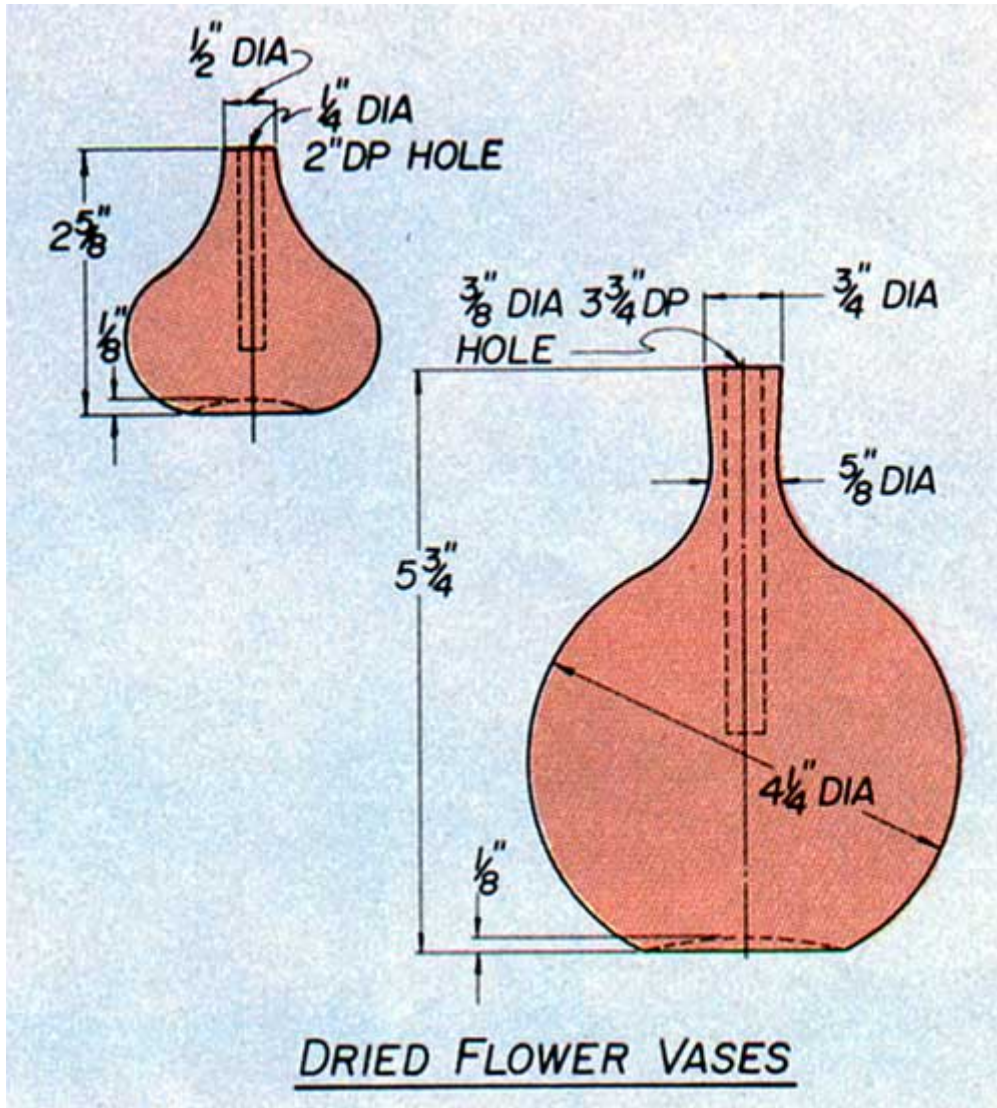

QUEEN ANNE LIVING ROOM TABLES



Here are three gorgeous tables that are surely destined to become the furnishing "stars" of your living room - or any room in your home. The end table and corner table feature a unique style of drawer joinery that we call a "beaver tail". And although these tables are, by no means, a "weekend project" or one for the inexperienced, if you take your time and follow our instructions, you should be able to produce results that you and your future generations will be proud of. For the best results, we recommend that you build them one at a time instead of tackling all three at once.

We wrote the construction procedures for this project with the emphasis on the more complicated techniques...assuming that the builder has learned the other, simpler techniques from work on previous projects.

Buying your materials

Regardless of whether you decide to build all three tables at once or one at a time over an extended period, it is extremely important that you purchase all of your materials at the same time to avoid miss-matches.

You'll need both 1" and 3" thick cabinet hardwood...preferably cherry, maple mahogany or walnut for this style of furniture. Buy 32-3/4 board feet of 3" (12/4) and 27-1/2 board feet of 1" (4/4) stock.

You'll also need a 1/2" x 7" x 60" piece of utility wood (poplar or similar) for the drawer sides and backs and a 3/4" x 7" x 20" piece of hard maple for the drawer glides. Add to this a quarter-sheet of 1/4" plywood and a 14" long piece of 1/4" birch dowel, plus the required hinges, drawer pulls, top retainers and wood screws. See the List of Materials for a complete, detailed shopping list.



Starting construction

Before you get started, be sure to check the alignment of all your machinery. With this project, precision cuts are CRITICAL! For that reason, it's also a good idea to re-check machine alignment periodically as you progress through the various stages of the project.

Start by cutting your stock to size according to the List of Materials. Do not cut the tabletop stock until later to minimize the potential of damage. Also, don't cut the drawer parts yet so they can be cut to exact size once the tables have been assembled.

If you're planning to place these tables in a room with thick, plush pile carpeting, you might want to consider making the foot pads of the legs 1/4" longer. This will allow the pads to sink deeper into the carpet without hiding the lower portion of the foot.

Cutting the patterns

While the glue is drying on any pieces of stock that have to be glued to size, lay out the Leg, Transition Block, Skirt and Lower Rail patterns on some plywood template stock. The Leg templates are made in two pieces. This is because the pattern must be drawn on the inside of the Leg on two surfaces.

Use a Scroll Saw or Bandsaw to first cut your template contours, then use your 2-1/4" diameter Shopsmith Drum Sander or your Extra Long Drum Sanding Set, a file and some sandpaper to smooth your templates. Be sure to keep the profiles and corners sharp when sanding.

Once your glued-up pieces are dry, cut them to final size.

Lay out and cut the leg joinery

Always position the sapwood on the inner corner of your Legs and mark the two outside faces. Accurately mark the reference lines around all four sides of each Leg. This line will be very important later on for positioning the Transition Blocks and the templates. Also, lay out an example of each mortise and socket on the top ends and sides of each different Leg. These are your pattern Legs.

Using the Horizontal Boring mode of your MARK V with a 1-1/4" diameter Forstner or Multi-Spur Bit, drill the round sockets in the top ends of all the front End Table and Corner Table Legs.



Switch to the Drill Press and use your Rip Fence with a shop-made fence extension, Flip-Up Rip Fence Stops and a 7/16" Brad Point Drill Bit to cut the mortises in each Leg.

Before gluing the Transition Blocks onto the Legs, take extreme care to match the grain pattern (edge grain and face grain). Align the top of the Transition Block EXACTLY with the reference line and mark each Block position of each Leg. Some exchanges may be required for the optimal matches.

Compound cutting the Legs

Start by tracing the leg patterns onto the insides of each leg. Use a Bandsaw Fence with a stop block to accurately (and consistently) cut the top post of each leg. This will save you a lot of time when the posts are later smoothed.

Using your Bandsaw with a 3/16" Blade, compound cut the Leg profile onto each Leg. Cut out all four Legs following the pattern shown in the plan. Remember to always cut to the OUTSIDE of the pattern line, so you can later use a Drum Sander and file to bring the Legs to their final dimensions.

NOTE: Click [here](#) to learn more about making compound cuts on the Bandsaw.

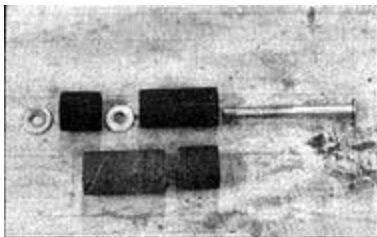

Fig. 1. Assemble an extra-long Drum Sander as shown.

Drum sand the upper insides of the Legs and the underside profiles of the Transition Blocks. Use a 3" to 4" long by 1" diameter Drum Sander for this job. If you don't have such a Sander, you can make a 3" Sander by combining a 1" x 1" and a 1" x 2" Sanding Drum as shown in Fig. 1...or a 4" Sander by combining two 1" x 2" Drum Sanders. Use long carriage bolts and washers to connect the Drums together, then secure the assembly in your Drill Chuck Jaws (See Fig 2.).

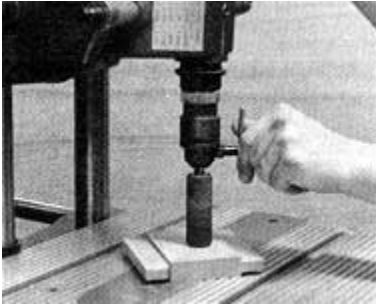

Fig. 2. Secure the Sander in your Drill Chuck.

Sculpting the Legs

Divide the Leg and Foot into quarters and mark the control lines as shown in Figure 3.

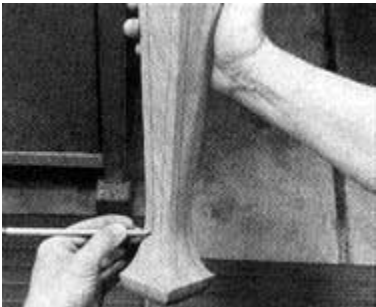

Fig. 3. Mark the control lines on the Leg and Foot.

Use masking tape or duct tape to shield the corners of the Transition Blocks from damage during the shaping process as shown in Figure 4.

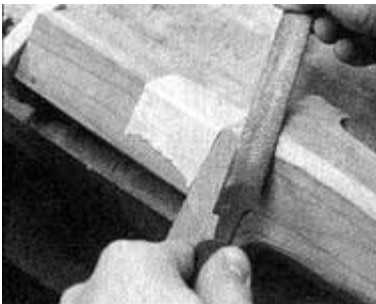

Fig. 4. Shield the corner from damage with tape.

Mount the Leg in a vise. Center and mark a circle on the bottom of the Foot. Use a backsaw to cut the three outside corners of the foot as shown in Figure 5. Cut from the first guideline on one face to the first guideline on an adjacent face.

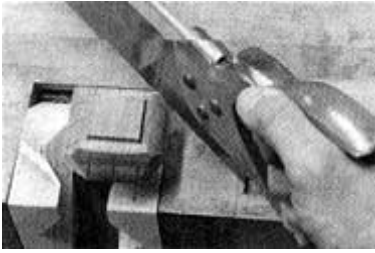

Fig. 5. Cut the three outside corners of the Foot.

Again, using your backsaw, cut across the corners of the pad to the outside edge of your drawn circle, forming an octagon as shown in Figure 6. Next, undercut these corners to your previous cuts to remove the waste. (See Fig. 7)

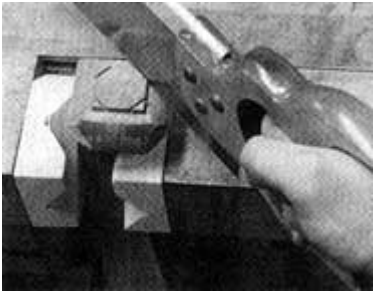

Fig. 6. Saw across the Foot Pad corners to form an octagon.

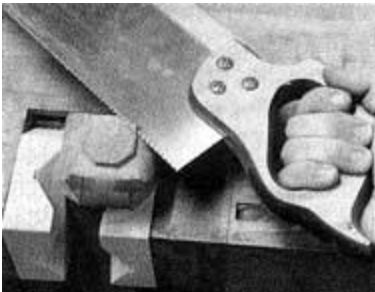

Fig. 7. Undercut the corners to remove the waste.

Using the edge of a rectangular, double-cut file, round the foot pads to your drawn circles as shown in Figure 8.

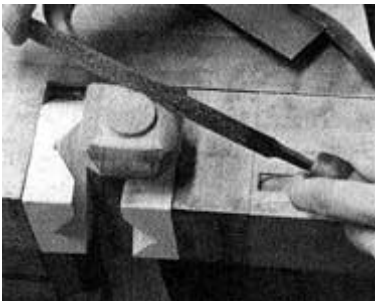

Fig. 8. Round the octagonal Foot Pad to your drawn circle.

Next, carefully round the three cut corners of the Foot to a circular shape, using a #50 cabinet rasp...then round the bottom of the Foot in a similar fashion. (See Fig. 9)

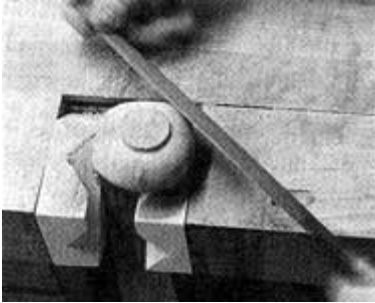

Fig. 9. Use a rasp to shape the Foot profile.

Mount the Leg in a Bar Clamp then grasp the Clamp body carefully in a bench vise for use as a sculpting fixture. Covering the Bar Clamp jaws with Double-stick tape will provide an improved non-slip grip.

Again, using your cabinet rasp, chamfer your Leg stock carefully at each corner, moving from the first line on one face to the first line on the adjacent face, as shown in Figure 10. Feather the flats progressively narrower to a point at the top, both sides and rear of the Knee...and both sides of the Foot. Feather a flat on the top of the Foot, making it wider, so the top is slightly flattened (See Fig 11).



Fig. 10. Chamfer the stock between control lines.



Fig. 11. Feather a flat on the top surface of the Foot.

Loosen your bar clamp, rotate the Leg a quarter-turn and re-secure the clamp. Chamfer all four corners of each Leg in a similar fashion.

Sculpt the Legs and Feet until they are close to their desired (and hopefully, identical) contours by filing each corner around the Legs to their marked centerlines. Additional rounding will be necessary. Be sure to leave some material for later removal by sanding. Take your time! (See Fig. 12.)



Fig. 12. Additional corner rounding will be required.

Sanding the Legs

Mount a pneumatic, contour sander in your Lathe and use it to bring the Legs to their final profile. Start with a coarse sleeve, then move to progressively finer sleeves, removing all filing and sanding marks as you bring the Legs and Feet to their final shapes. Remember to always sand with the grain whenever possible. (See Fig. 13.)

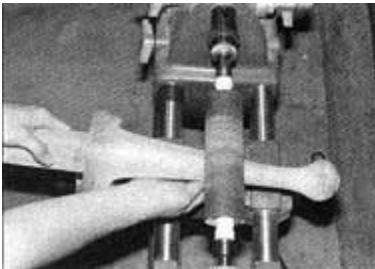

Fig. 13. Use a Contour Sanding Drum to finish sand the Legs.

Use a small block plane to smooth the Leg Posts. It must be VERY SHARP, because you'll be planing nearly across-grain and a dull plane iron will surely tear the wood. (See Fig. 14.)



Fig. 14. Use a Block Plane to smooth the Leg Posts

Making the Table Skirts

Start by marking-out a trial tenon on an identically-sized piece of scrap.



Using this scrap piece, set-up your Table Saw and make the cuts with a Tenoning Jig.

As an alternative, you could also use your Rip Fence as a stop to position the shoulder of the Tenon and your Miter Gauge to guide your stock past the blade as you make your cuts.

Next, fit your tenons into their respective mortises, using a sharp bench chisel. Use your Disc Sander to chamfer the tenon ends slightly to allow for glue and make them easier to insert into their mating mortises.

Once you're confident that the joinery fits properly, trace a line on the tops of the Transition Blocks along the side. Round the top of the Transition Blocks to meet the line marking the bottoms of the Skirt edges.

Stack together and align the bottom edges of all similar Skirts and Lower Rails. Use masking tape to hold them together in the stacks. Layout each pattern on the top board of each stack, then use your Bandsaw to pad saw the lower contours of all Skirt and Rail sets.

Carefully cut the Drop Leaf Supports out of the Coffee Table side Skirts while they're still taped together. Use the long Drum Sander you created earlier to sand all the sawn contours BEFORE un-taping the stacks.

Once the sawn edges are sanded, tape the Drop Leaf Supports back into position in the Skirts from which they were removed. Using your Horizontal Boring setup, drill and counterbore the support pivot holes for #10 x 1-1/2" round-head wood screws. Install the screws and un-tape the supports.

Using a ripping blade on your Table Saw, cut the Top Retainer Slots in the Side skirts of the Coffee Table -- and the Upper Front Rails and the End Skirts of the End Table and the Corner Table. Mounting the Top Retainers in these pieces will allow unrestricted expansion and contraction of the tops with changes in temperature and humidity. Also, the Inside Drawer Glide will not interfere with the Top Retainer installation.

Prior to assembly, sand the Skirts and Rails thoroughly to remove any planer or Belt Sanding marks.

Drawer Glide Construction

The End Table and Corner Table Drawer Glides are formed by simply cutting rabbets in the edges of narrow boards. However, prior to making these rabbet cuts, drill and counterbore the holes for #10 x 1-1/4" roundhead wood screws in the edges of the stock, then cut the notches in their ends



using your Bandsaw. Finally, form the required rabbets by using your Table Saw with a Dado Blade or Molding Set-up and a straight-edged 1" Jointer Knife Set.

Insert the screws into the drilled holes and use them as "punches" to mark the pilot hole positions on the inside of the Sides. Use your Drill Press with a 1/8" bit to drill the pilot holes in their marked positions.

Table Assembly

Prior to gluing-up the Tables, dry assemble and clamp each Table together to verify the proper fit of all components. If all goes together nicely, remove the clamps and disassemble the pieces.

Start the assembly process by gluing and clamping the front and rear pieces to their Legs. Be sure to wipe the glue squeeze-out from the wood with a water-soaked rag. Once the glue has dried thoroughly, assemble the Front and Rear sections together with the Sides and remove the glue squeeze-out in the same manner.

Drawer Construction

Begin by measuring the drawer openings to double-check the drawer sizes against the List of Materials...then cut all Drawer components to size, as required. Plan to leave a 1/16" space on the Drawer Sides and Tops to provide room for the Drawers to move in and out freely. Remember, the Drawer Fronts are larger than the openings to allow for 3/8" rabbets on the insides to recess the Fronts.

Cut the rabbets around the Drawer Fronts. Use your Jointer, Router Table Set-Up or Shaper to achieve the smoothest possible cuts.

Drilling Drawer Front Sockets

Lay out the joinery on a piece of identically-sized scrap stock. Remember, this piece must be EXACTLY the same thickness and width as the Drawer Fronts (length isn't critical).

Using the Horizontal Boring set-up, use your Miter Gauge as a guide and sliding position controller. Working with a 5/8" Brad Point Drill Bit, clamp stop blocks in the Miter Gauge slots to limit the travel of the Miter Gauge when drilling the upper and lower side sockets (See Fig. 15). Use an easily-removable 1" long wooden spacer to fit between your Stop and the Miter Gauge Bar to position the center hole. All three hole positions MUST be

EXACTLY symmetrical from the center of the width of the front and no more than 1/64" away from the edge of the rabbet.

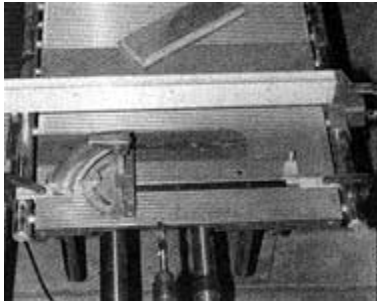

Fig. 15. Set-up for drilling the Drawer Front joinery.

Use your trial piece of stock with the joinery laid out on it to set up the stops on the exact centers and drill the 1/2" deep test sockets.

Once all is set precisely, position the Rip Fence as a back stop and set your drilling depth-of-cut to the exact thickness of the sides. Drill all sockets in the ends of the first Drawer Front (See Fig. 16). Reposition the Fence and Depth Stop accordingly and drill the Sockets in the second Front. **DO NOT CHANGE THIS SET-UP...**it will be used later!

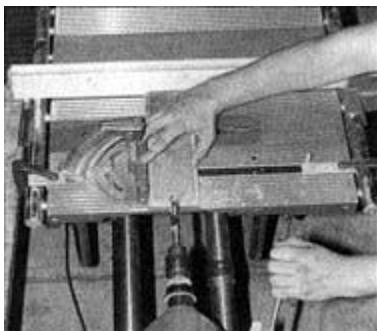

Fig. 16. Drilling the Sockets in the Drawer Front ends.

Cutting Drawer Side Pins

Lay an end of a Front piece on a stack of corresponding Side pieces that have been taped together in perfect alignment and hold the Front piece firmly against the end of the taped-together sides. Align the bottom of the sides with the bottom rabbeted edge of the Front and trace the positions of the sockets onto the top side of the stack of Sides (See Fig 17.)

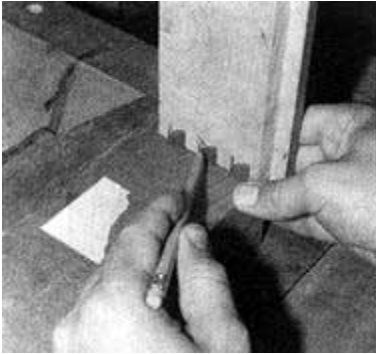

Fig. 17. Trace the sockets on the stack of Sides

Pad saw all of the Drawer Sides to the traced sockets using your Bandsaw with a 1/8" Blade. Be sure to stay on the OUTSIDES of your lines

Using an EXTREMELY SHARP bench chisel, carefully shave the pins cross-grain, just to the cutting line while all the pieces are still taped together (See Fig. 18). Verify the fit of the pins to the sockets in the Front piece by checking them at both sides of your stack



Fig. 18. Shave all the pins in the stack just to the line.

When you're confident that the fit is perfect, untape your stack of Side Pieces. Trial assemble the Sides in their proper positions and make any adjustments to their fit, if necessary.

Drilling the dowel holes in the Tails

Using the same Horizontal Boring set-up that you used to drill the sockets in the Drawer Fronts, dry assemble the Drawer Fronts and Sides then drill 1/4" diameter dowel holes through the exact centers of the Tails and into the Drawer Fronts (See Fig. 19). Number each assembled Drawer joint so you'll know which pieces join together during the final assembly process.

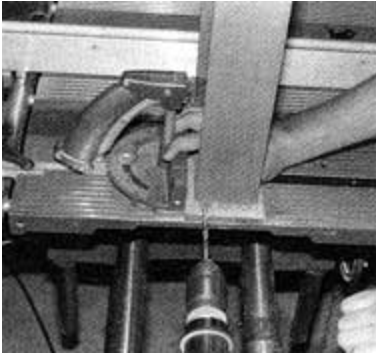

Fig. 19. Drill the 1/4" dowel holes in the Drawer assembly.

Using a 1/2" wide Dado set-up on the Table Saw, cut the vertical back Dado in each Drawer Side. Then use a 1/4" wide Dado set-up to saw the bottom grooves in each Drawer Side. Do not glue-up the Drawers yet.

Making the tops

Saw, joint and glue-up the stock for the three Top pieces. Use a Hand Scraper to scrape away the excess glue and plane and/or sand the pieces smooth. Cut the Top pieces to size according to the List of Materials.

Use the Shaper set-up with a Drop-Leaf Cove Cutter and Drop Leaf Bead Cutter to cut the rule joints on the edges where the Center Top piece and Drop Leaf side pieces of the Coffee Table meet.

While you have your Shaper set up, change to a 1/4" Quarter-Round Cutter and round-over the top edges of the Drawer Sides. Switch to the Bead & Quarter-Round Cutter and cut the decorative thumbnail edges around the Drawer Fronts.

Next, clamp the three Coffee Table top parts gently together while you lay out the Top profile. Since each drop-leaf joint will overlap by about 3/8", the finished size of the Top will be 30" x 40".

Turn your Table over and draw your oval layout on the underside. Begin by drawing perpendicular horizontal and vertical centerlines for your oval as shown in Fig. 19-A. These lines will be your minor (A/B) and major (C/D) axes.

Fig. 19-A.

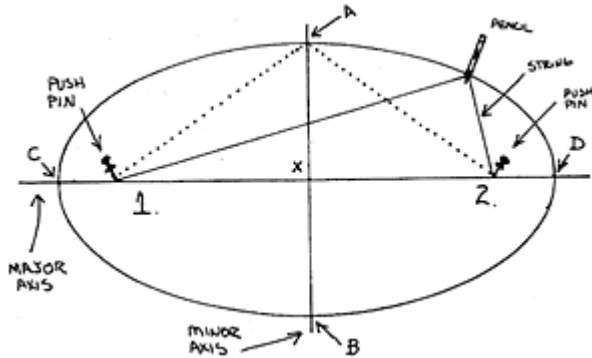

Set a large compass to the distance CX (in our case, this should be half the width of our Table Top or 20"). Position the compass point at location A and strike an arc across the major axis line at points #1 and #2.

Take a long piece of string or heavy thread and tie it into a continuous loop that will be equal to the distance between points "C" and "2", when the loop is pulled taut (In other words, if your push pins were inside your tied loop at points "C" and "2", the loop would be taut.)

Drive your two push pins lightly into the underside of the Top at points #1 and #2 on your layout. Slip your tied loop over the outside of your push pins. Position the point of a pencil or marker inside your string loop at location "A" and begin moving your pencil or marker point around the layout in a clockwise manner...dragging the string loop with you as you finish drawing your oval.

Mortise and mount the drop-leaf hinges to the underside of the Top. Note the relationship of the hinge pin in the joint (See Fig. 20). Remove the clamps.

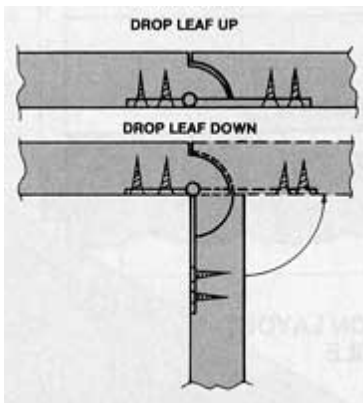

Fig. 20. Hinge pin-to-rule joint relationship

Use your Bandsaw to cut the oval profile, then carefully sand the edges smooth using your Disc Sander. Next, use a Guide Pin Shaper set-up with an



Ogee Cutter and Rub Collar to cut the decorative edge around the assembled oval Coffee Table Top. This set-up will allow the Shaper to cut into the Top slightly beyond what the plans call for. Sand away this unwanted ridge around the edge with your Disc Sander.

Drill the Top retainer screw holes on the underside of the table Tops, 1-1/2" away from the Leg Post positions.

Assemble the Drawers with glue, 1" long Drawer dowels and bar clamps. Wipe the glue squeeze-out from the wood with a water-soaked rag.

Sand, sand, sand and sand some more...then apply the finish of your choice.

Drop-Leaf Coffee Table

#of Pcs	Size	Descriptions	Material
4**	2-3/4 x 2-3/4 x 15-1/4	Leg	Cherry
8	2 x 2 x 2	Transition Block	Cherry
2	3/4 x 4-1/2 x 28-1/2	Side Skirt	Cherry
2	3/4 x 4-1/2 x 12	End Skirt	Cherry
1	3/4 x 16-1/4 x 40-1/4	Center Top	Cherry
2	3/4 x 7-1/4 x 40-1/4	Drop Leaf	Cherry
4	5/64 x 5/8 x 1-1/2	Top Retainer Woodscrew	Steel
2	#10 x 1-1/4	Roundheadd Woodscrew	Steel
4	1-1/2 x 3	Drop Leaf Hinge with Screws	Brass



Queen Anne End & Corner Tables with Drawers

#of Pcs	Size	Descriptions	Material
4**	2-3/4 x 2-3/4 x 21-1/4	Leg	Cherry
8	2 x 2 x 2	Transition Block	Cherry
2	3/4 x 5-1/4 x 20	Side Skirt	Cherry
1*	3/4 x 5-1/4 x 12 (20)	End Skirt	Cherry
1*	3/4 x 1-1/4 x 12 (20)	Lower Front Skirt	Cherry
1*	7/8 x 1-3/4 x 12 (20)	Upper Front Rail	Cherry
1*	3/4 x 16 (24) x 24	Top	Cherry
1*	7/8 x 4 x 10-5/8 (18-5/8)	Drawer Front	Cherry
2	1/2 x 3-3/16 x 20-1/2	Drawer Side	Utility Wood
1*	1/2 x 2-11/16 x 9-1/2 (17-1/2)	Drawer Back	Utility Wood
1*	1/4 x 9-1/2 (17-1/2) x 19-3/4	Drawer Bottom	Plywood
2	3/4 x 1-1/2 x 19-3/4	Drawer Glide	Hard Maple
6	1/4 Dia. x 1 Long	Drawer Dowel	Birch
1	1-3/4 x 3-3/4	Drawer Pull	Brass
4	5/64 x 5/8 x 1-1/4	Top Retainer Woodscrew	Steel
4	#10 x 1-1/4	Roundhead Woodscrew	Steel

* Increase the length of these pieces as shown in parentheses to make the End Table into the Corner Table and double the number of pieces required.

** Add 1/4" to the length if making a higher foot pad for use on plush carpeting.

COFFEE TABLE

Side View

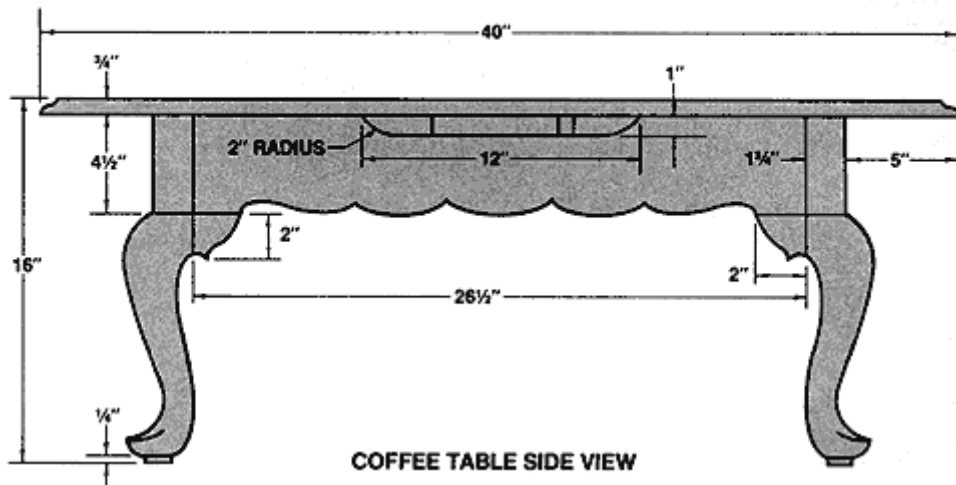
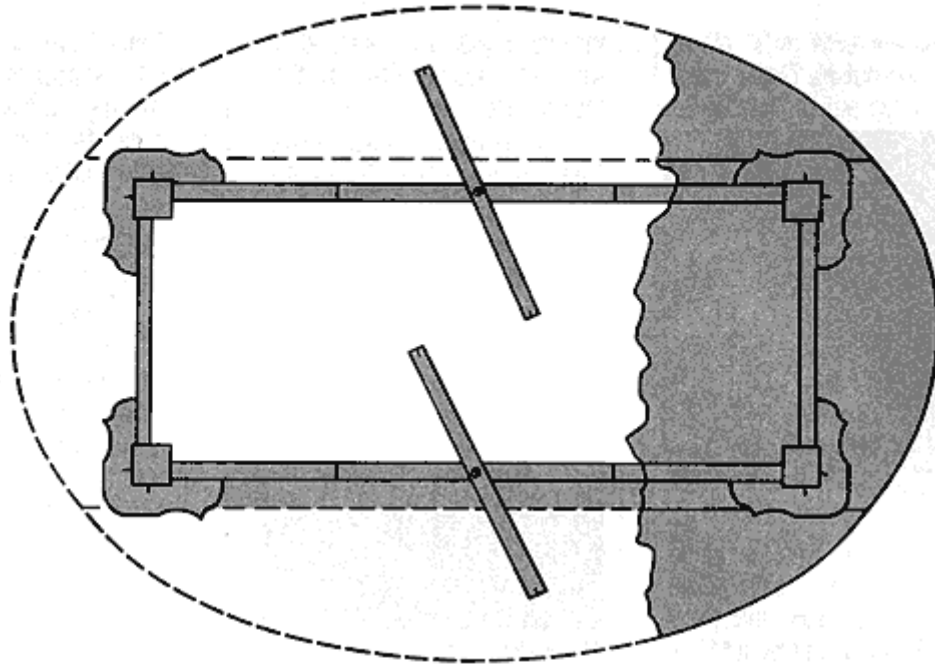

Side Skirt and Tenon

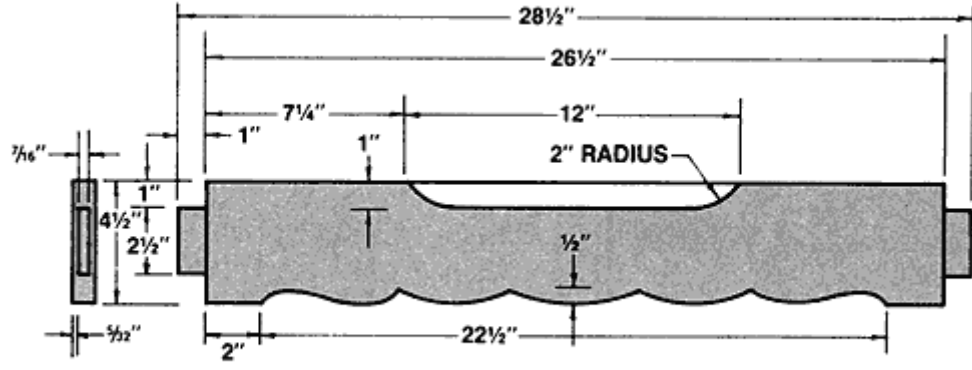

**SIDE SKIRT AND TENON LAYOUT
 COFFEE TABLE**

Leg Joinery

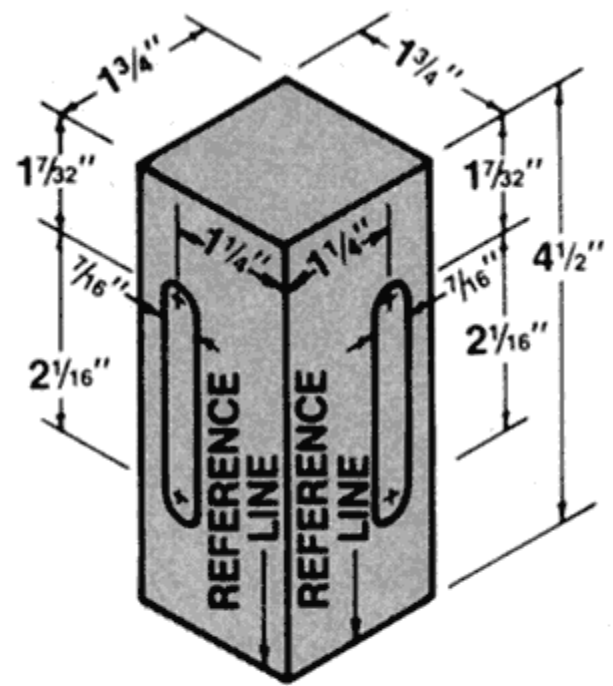

**INSIDE OF ALL LEG POSTS
 FOR COFFEE TABLE
 LEG JOINERY**

Table End Skirt and Tenon

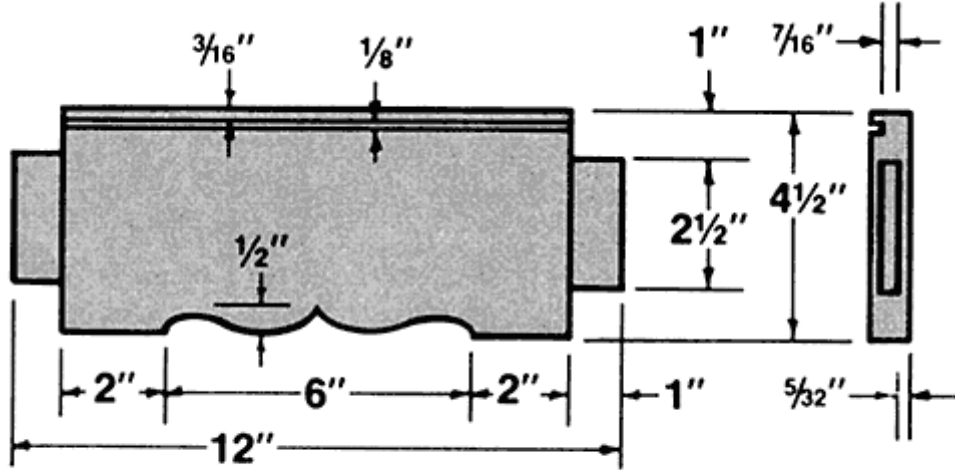

**COFFEE TABLE END SKIRT
AND TENON LAYOUT**

Drop Leaf Support

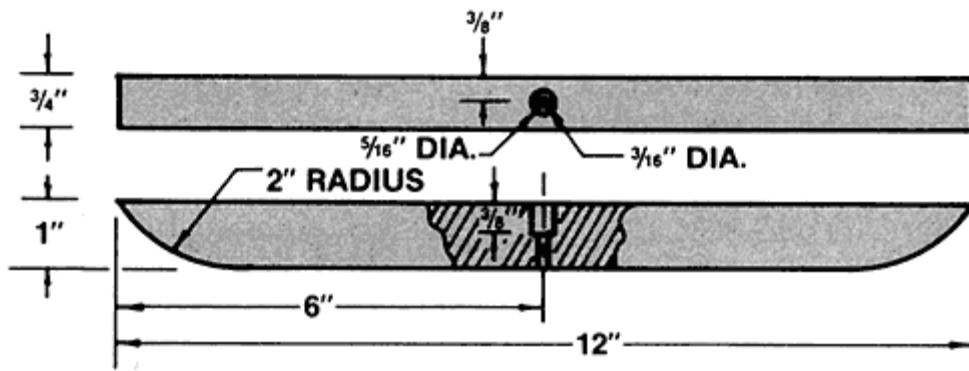

**DROP LEAF SUPPORT
COFFEE TABLE**

Leg Pattern

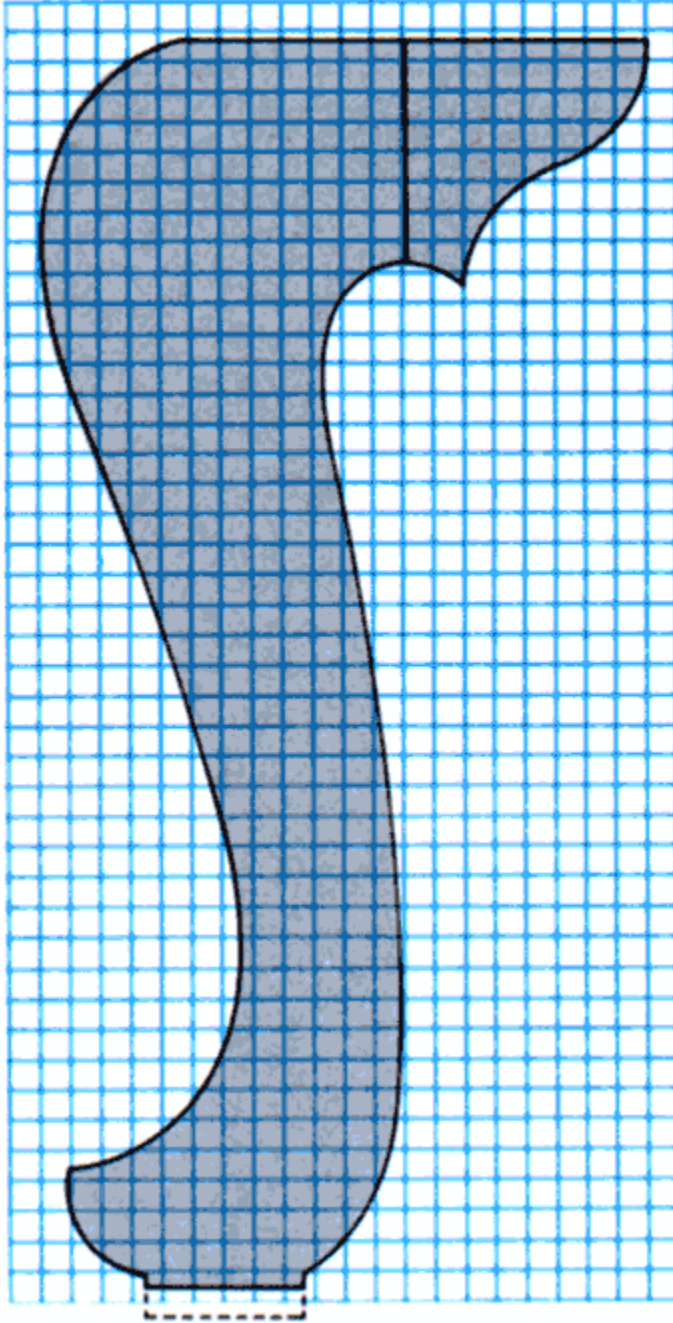

Side Skirt Pattern

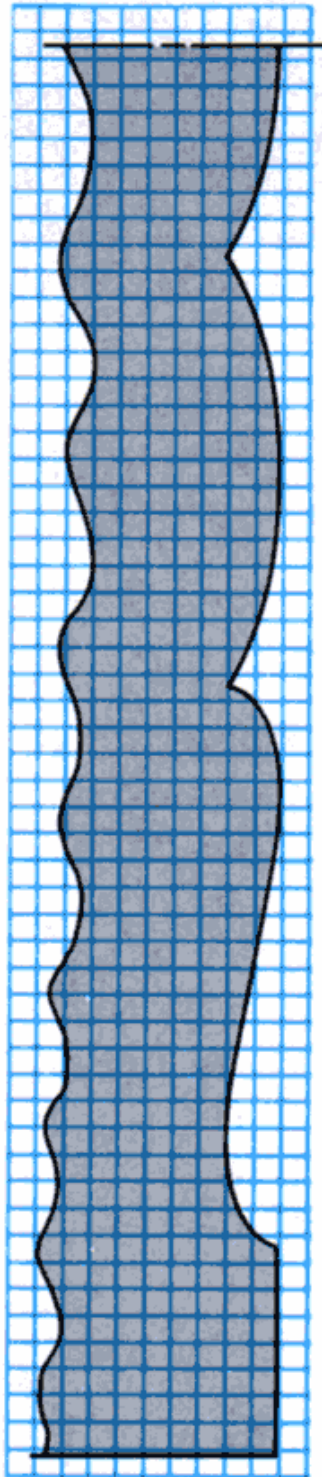

End Skirt Pattern

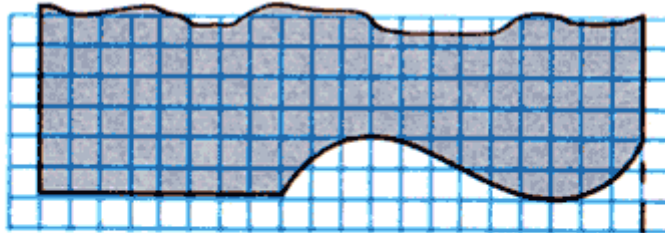

**COFFEE TABLE AND END TABLE
END SKIRT PATTERN 1/4" GRID**

END AND CORNER TABLE

Side View

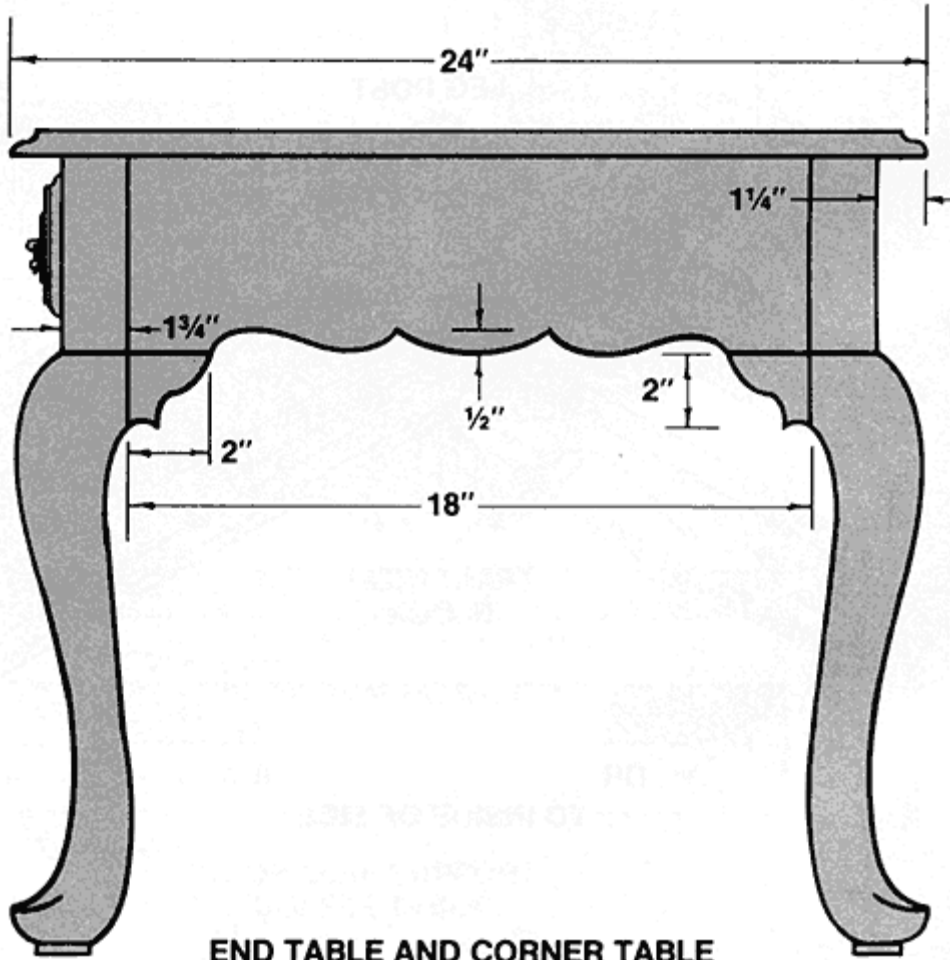

**END TABLE AND CORNER TABLE
SIDE VIEW**

End Table Front View

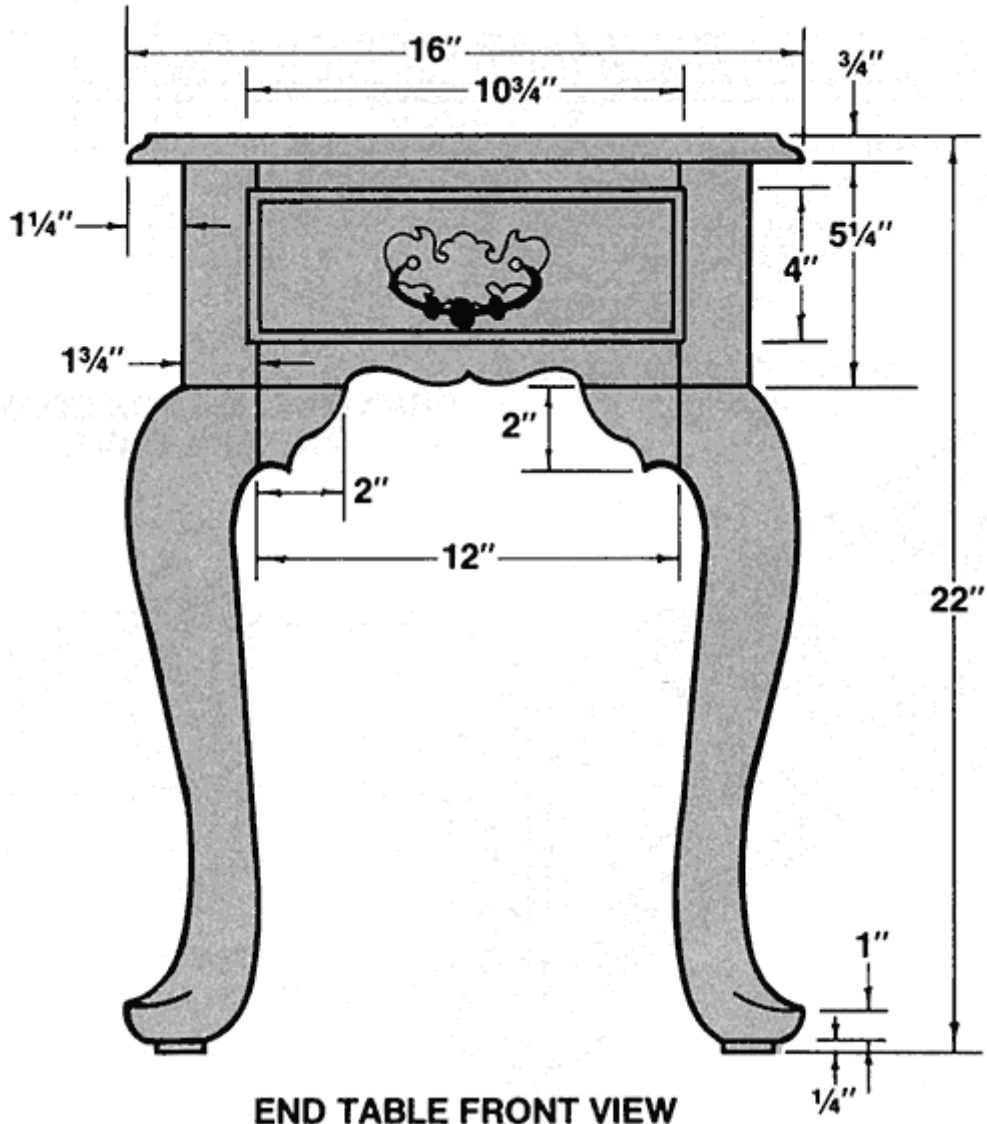

Leg Joinery

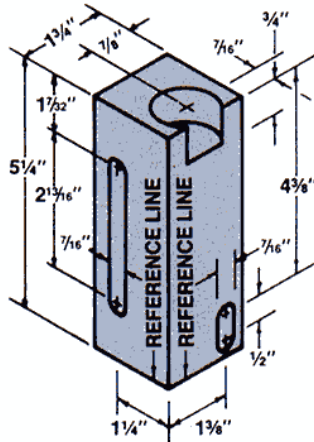

**INSIDE OF FRONT LEFT LEG POST
(FRONT RIGHT POST IS MIRROR IMAGE)
FOR CORNER AND END TABLE**

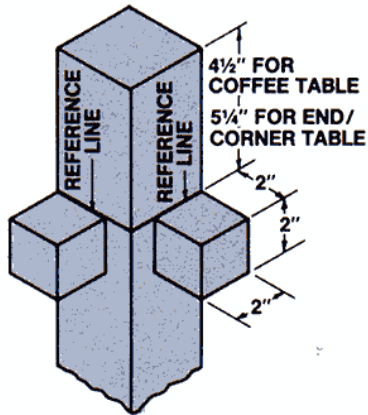

**TRANSITION
BLOCK LAYOUT
FOR ALL TABLES**

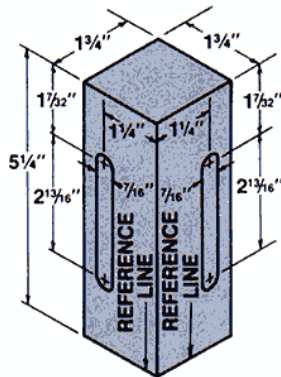

**INSIDE LEFT AND RIGHT REAR LEG POST
OF CORNER AND END TABLES**

Table End Skirt and Tenon

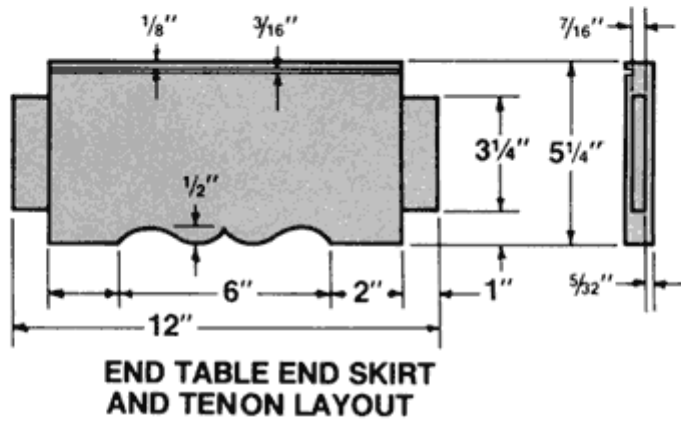
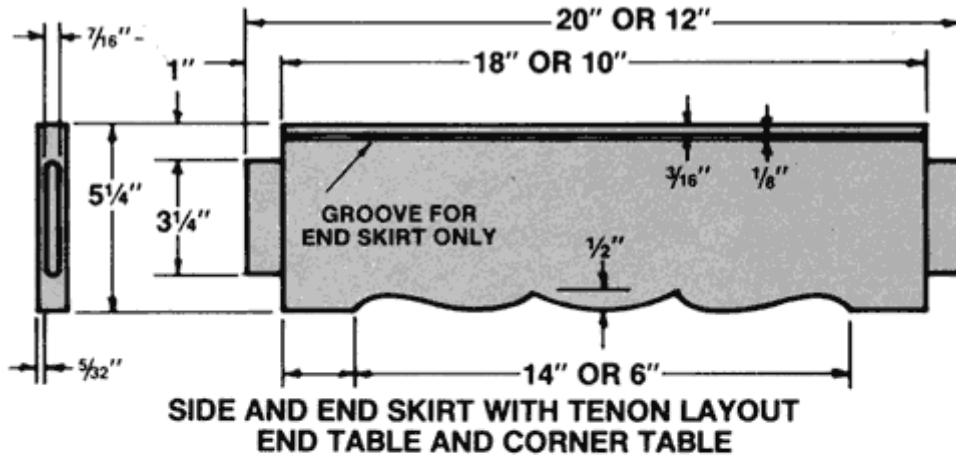

Rail and Pin Tenon

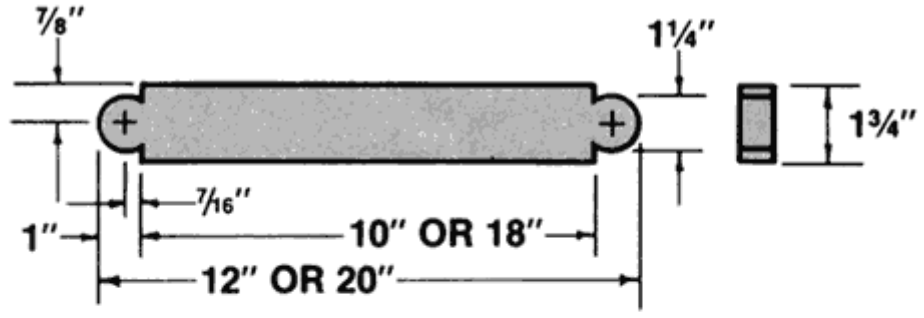

**UPPER FRONT RAIL AND PIN LAYOUT
END TABLE AND CORNER TABLE**

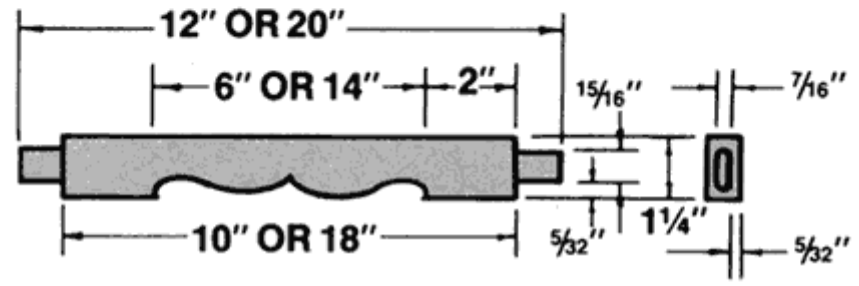

**LOWER FRONT RAIL AND TENON LAYOUT
END TABLE AND CORNER TABLE**

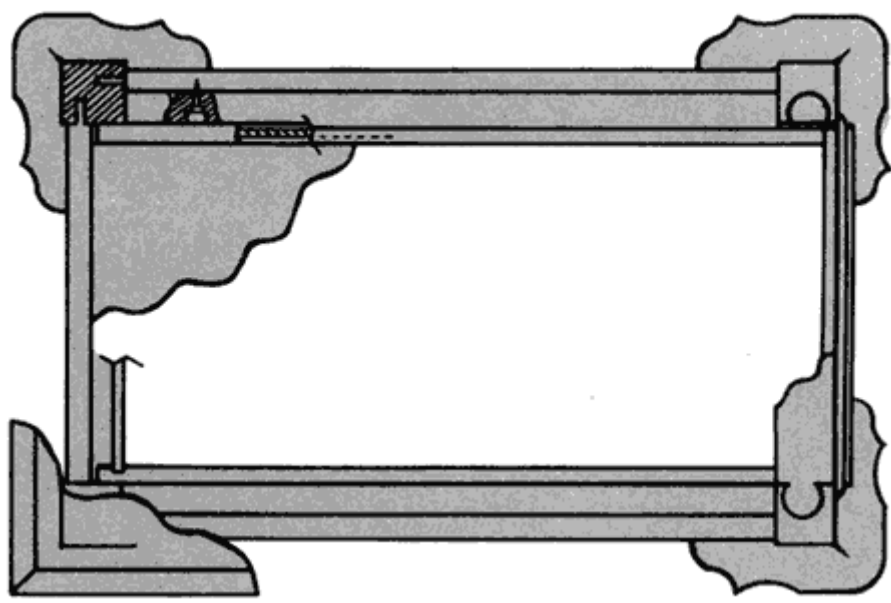

Leg Pattern

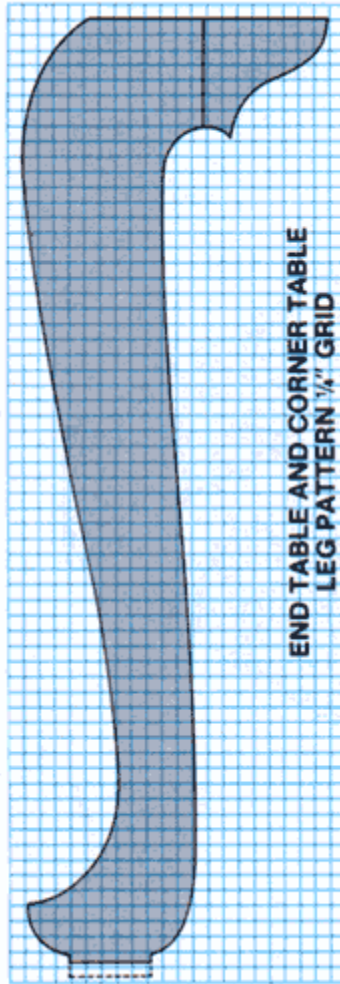

Side Skirt Pattern

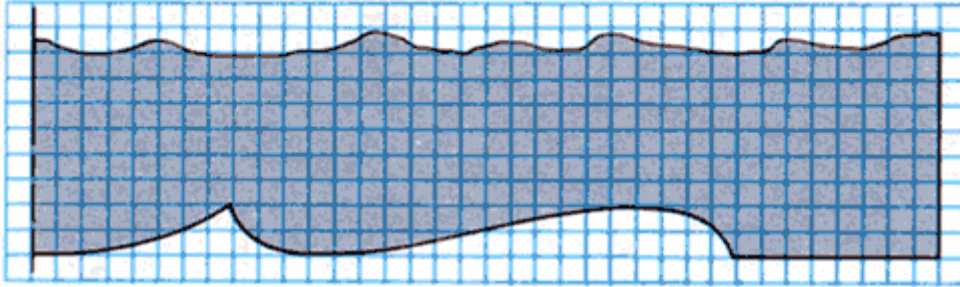

**END TABLE SIDE SKIRT PATTERN AND
CORNER TABLE SIDE AND END
SKIRT PATTERN AND CORNER TABLE
LOWER FRONT RAIL PATTERN 1/4" GRID**

End Skirt Pattern

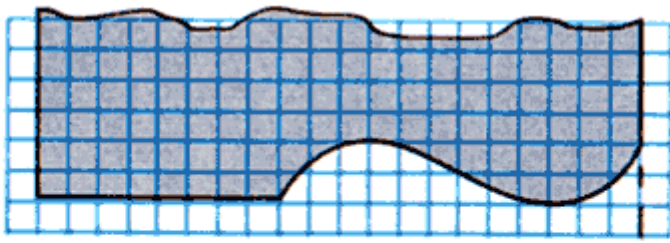

**COFFEE TABLE AND END TABLE
END SKIRT PATTERN 1/4" GRID**

Drawer Assembly

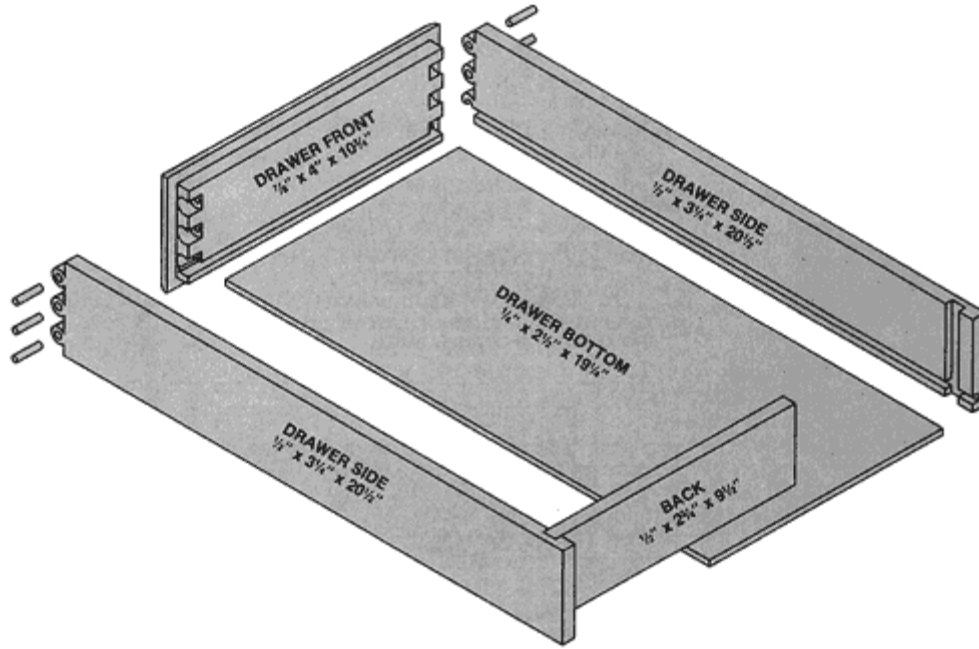

Drawer Joinery

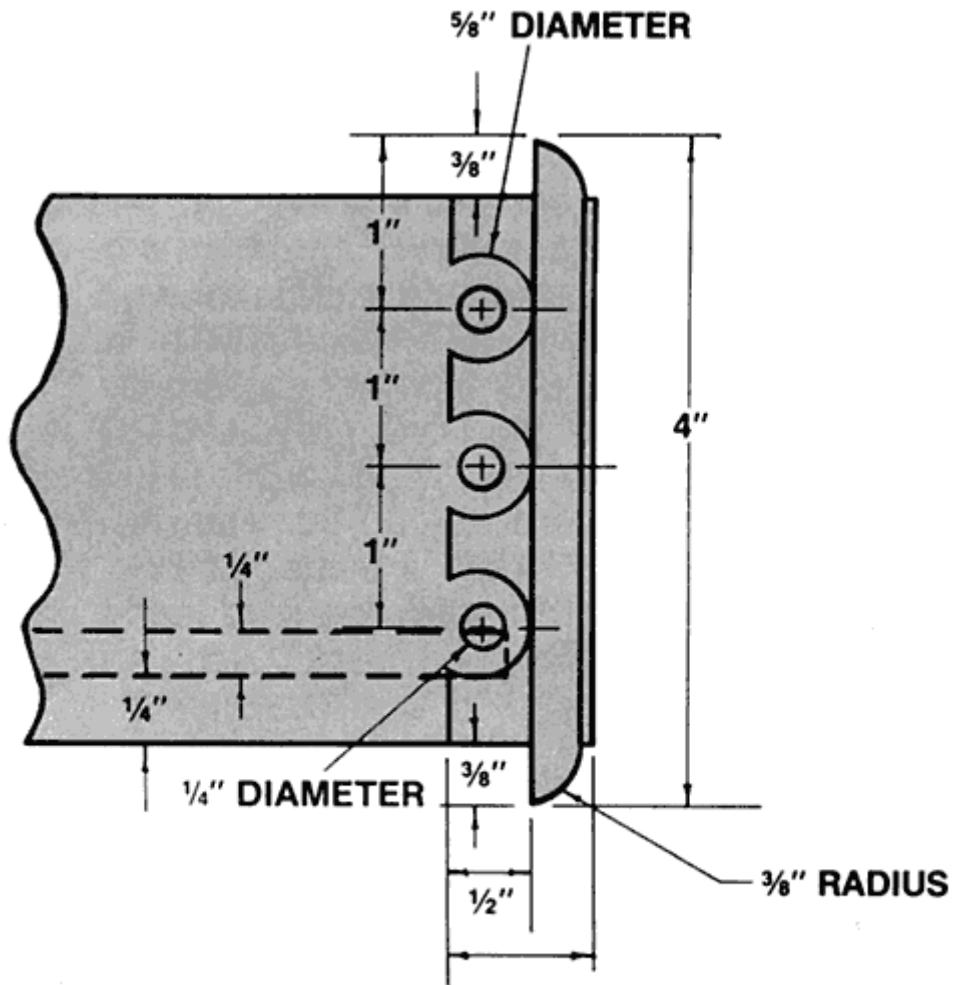

**DRAWER SIDE TO FRONT JOINERY
END TABLE AND CORNER TABLE**

Drawer Glide

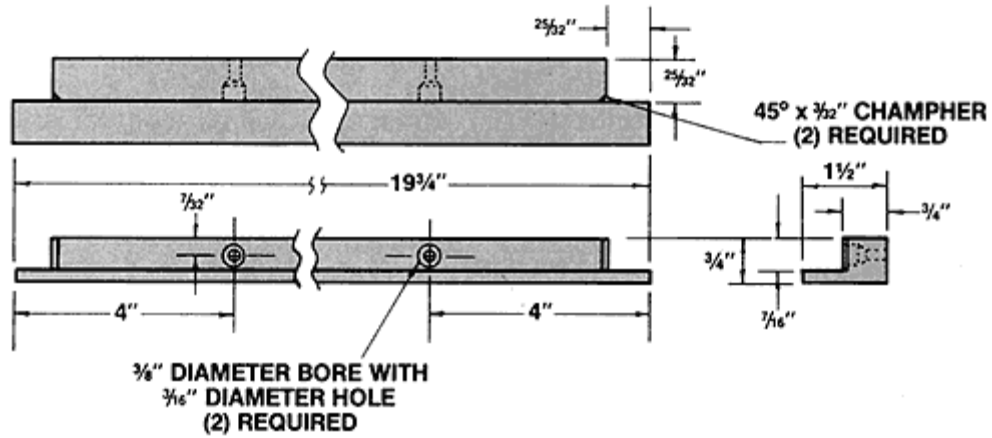

DRAWER GLIDE FOR CORNER AND END TABLE

Drawer Glide Assembly

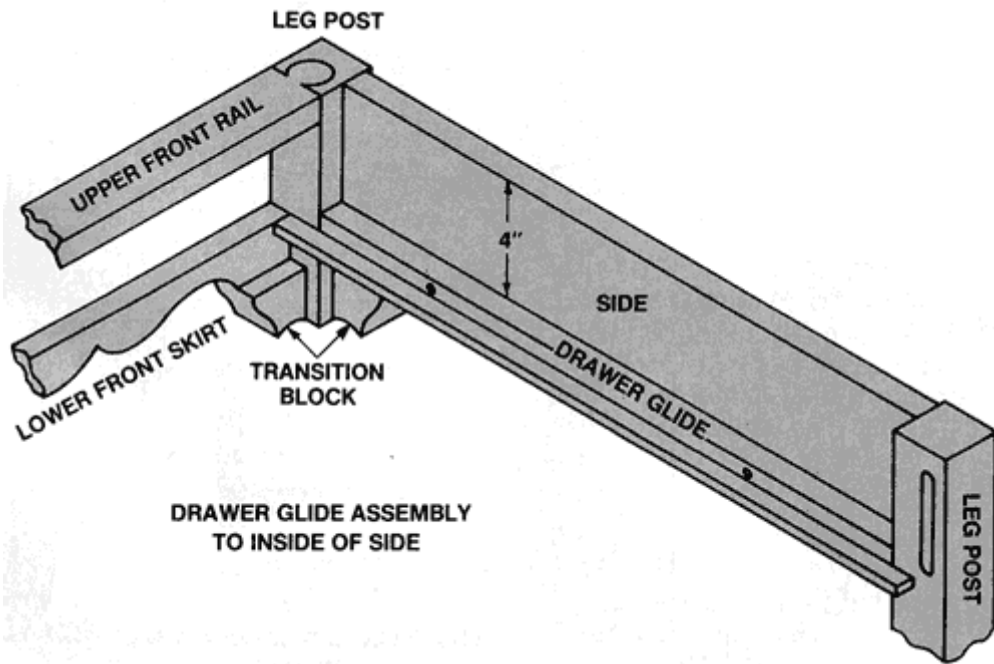

DRAWER GLIDE ASSEMBLY TO INSIDE OF SIDE



THREE-PIECE CONSTRUCTION CREW



The Projects

General Instructions:

I use #2 pine, 3/4" thick for all of my toys. Some of the toymaking books tell you to buy special stock, but I disagree. Once I get 3/4" stock resawn on the Bandsaw, I get the basic parts cut quickly.

To make wheels, I start with close-grained stock. I use a 2-3/8" dia. hole saw to cut half-way through...just until the pilot bit punches through the back side. Then, I switch to a 2-1/8" dia. hole saw and insert it into the same pilot hole. This saw makes a 1/8" deep concentric kerf in the wheel to help define the 'tire' from the 'hub'. Then, I turn the stock over and complete the wheel cutout with the 2-3/8" hole saw...again, in the same pilot hole. Larger wheels can be made easily on a Bandsaw or Scroll Saw, then sanded down on a Disc or Belt Sander.

Once assembled, you can leave them unfinished or seal them with a non-toxic finish such as Salad Bowl Finish.

THE BULLDOZER

This toy features lifelike bulldozer tracks and a two-position blade that's held off the ground by the exhaust stack engaging a hole in the blade axle. The builder must watch that the chassis center beam (A) and chassis end beams (B) are cut exactly to size, as shown in the Bill of Materials. This provides adequate clearance for the wheels when the tracks are glued to the chassis.

Start by cutting all parts to size, according to the Bill of Materials. Drill axle holes in (A). Glue parts (B) to (A). Install wheels.

Glue track lugs (G) onto track blocks (F), starting on the top and bottom center and working toward the ends. Use a spare lug as a spacer. For lugs



glued on the rounded ends, wrap sandpaper over a large dowel...or use a 1-1/2" diameter sanding drum to sand a concave surface for better adhesion. Drill hole for the blade axle (L). Insert blade axle and drill a 1/4" dia. hole for the exhaust stack (M). This hole goes through the blade axle. Remove the blade axle and redrill the 1/4" dia. hole to 5/16" dia. Drill dashboard holes for the gauges and insert gauges (P).

Blade (K) has a concave face. This shape can be achieved by sanding over the Idler Drum end of your Belt Sander or by using a Drum Sander. Assemble the blade (K), blade axle (L), blade supports (J) and engine (H).

All parts of this toy are held together with glue only. Be sure to round all sharp edges for added safety.

THE TRACTOR

Cut all parts to size according to the Bill of Materials. Saw and drum sand the circular window through the cab (B). Drill the 1/4" dia. hole for the steering wheel shaft (K).

Use a 2-1/2" hole saw, Band saw or Scroll Saw to cut the circular outlines in the fenders (D)...then use your Disc Sander or Belt Sander to round the fenders' top and front outside edges. Caution: Remember that there's a left and right fender - and they're not interchangeable - so be careful which edges you round!

Make and assemble the wheels (E), axles (G) and carriage (E). Cut and drill the hitch (H). Turn exhaust stacks (J) from 3/4" dowel. Drill 1/8" "ventilation holes" in them for detail. Drill holes in cab light block (M) and use 1/4" dowels for lights. Shape the front bumper (N), round all sharp edges, assemble and glue all parts together.

THE LOW-BOY TRAILER

Cut all parts to size according to the Bill of Materials. Drill the two axle holes in the carriage (D) and glue the two pieces together. Make and assemble the wheels (E), axles (F) and carriage (D).

Cut the coupling arm (B) to shape. Glue this onto the floor (A). After the glue has set, reinforce this butt joint with a flush-set 3/8" dowel. Round all sharp edges.

Assemble and glue all parts together.



LIST OF MATERIALS

(finished dimensions in inches)

The Bulldozer

A	Chassis center beam	1 x 1-1/2 x 4-1/4
B	Chassis end beams (2)	3/4 x 1-1/2 x 2-3/4
C	Wheels (4)	3/4 x 1-1/4 dia.
D	Axles (2)	1/4 dia. x 2-5/8
E	Chassis platform	1/4 x 2-3/4 x 5-3/4
F	Track blocks (2)	3/4 x 1-1/2 x 6
G	Track lugs (6)	3/8 x 3/16 x 3/4
H	Engine	2 x 2-1/4 x 3-3/4
J	Blade Supports (2)	3/4 x 2-3/4 x 4-1/2
K	Blade	3/4 x 2-3/4 x 6
L	Blade axle	1/2 dia. x 4
M	Exhaust stack (2pcs.)	1/4 dia. x 2
N	Seat	3/4 x 3/4 x 1-1/2
	Seat side (2)	1/8 x 1 x 1-1/4
	Seat back	1/8 x 1-1/4 x 1-1/2
P	Gauges (4)	3/8 dia. x 1/2
Q	Control levers (3)	1/8 dia. x 1-1/4

The Tractor

A	Base	3/4 x 3 x 7
B	Cab	3 x 3-1/4 x 4-1/4
C	Grill	3/8 x 2-1/2 x 3
D	Fenders (2)	3/4 x 2-1/2 x 3-1/2
E	Front Carriage	3/4 x 1-1/4 x 3
	Rear Carriage	3/4 x 1-1/4 x 2
F	Wheels (6)	3/4 x 2 dia.
G	Axles (2)	1/4 dia. x 4-5/8
H	Hitch	3/4 x 1-1/2 x 2
J	Exhaust stacks (2)	3/4 dia. x 5-1/4
K	Steering wheel	1/4 x 1-1/4 dia.
	Steering wheel shaft	2-1/2 x 1/4 dia.
L	Headlights	3/4 dia. x 1/2
M	Cab light block	3/8 x 1/2 x 2



	Cab lights(3)	1/4 dia. x 1/2
N	Front bumper	1/4 x 1-1/4 x 4-1/2

The Low-Boy Trailer

A	Floor	3/4 x 5-3/4 x 12
B	Coupling arm	3/4 x 2 x 4-3/4
C	Coupling pin	3/8 dia. x 1-5/8
D	Carriage (2pcs.)	3/4 x 2-1/4 x 3-3/4
		3/8 x 2 x 3-1/2
E	Wheels (4)	3/4 x 1-1/4 dia.
F	Axles (2)	1/4 dia. x 5-1/4
G	Stops (2)	3/8 x 3/8 x 5-1/2
H	Dowel	3/8 dia. x 2-5/8

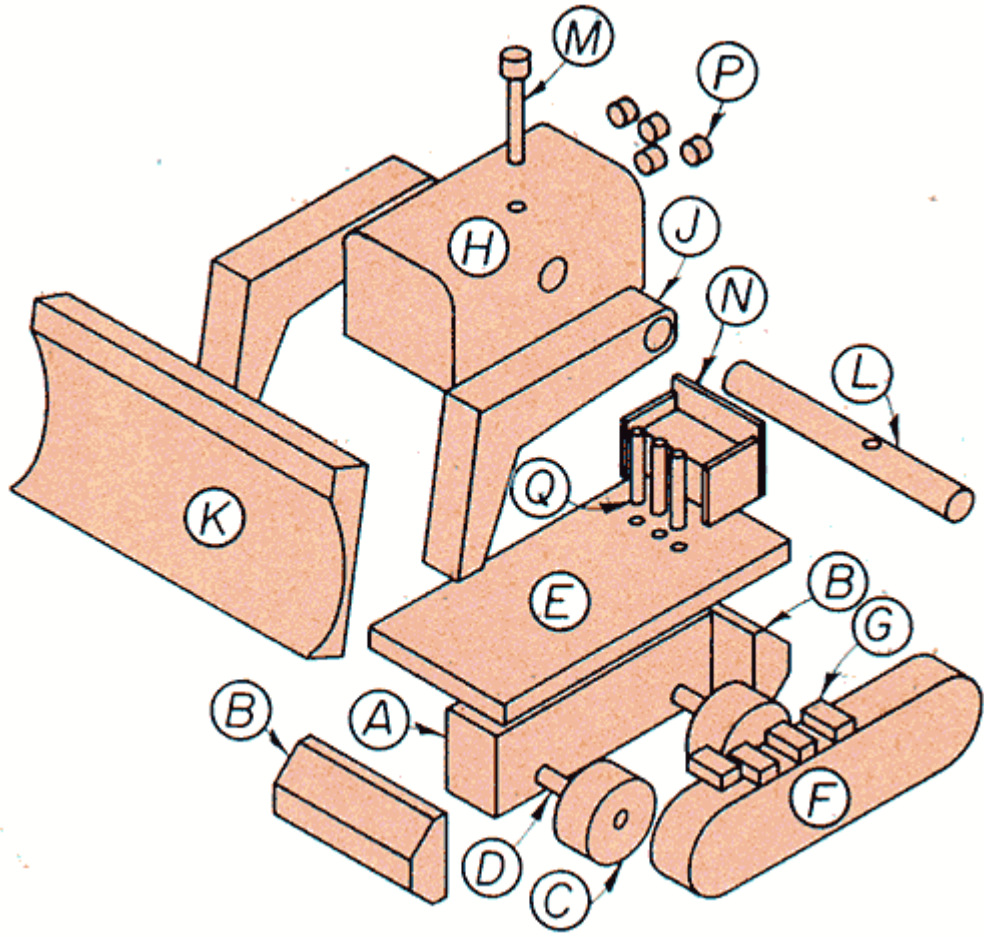

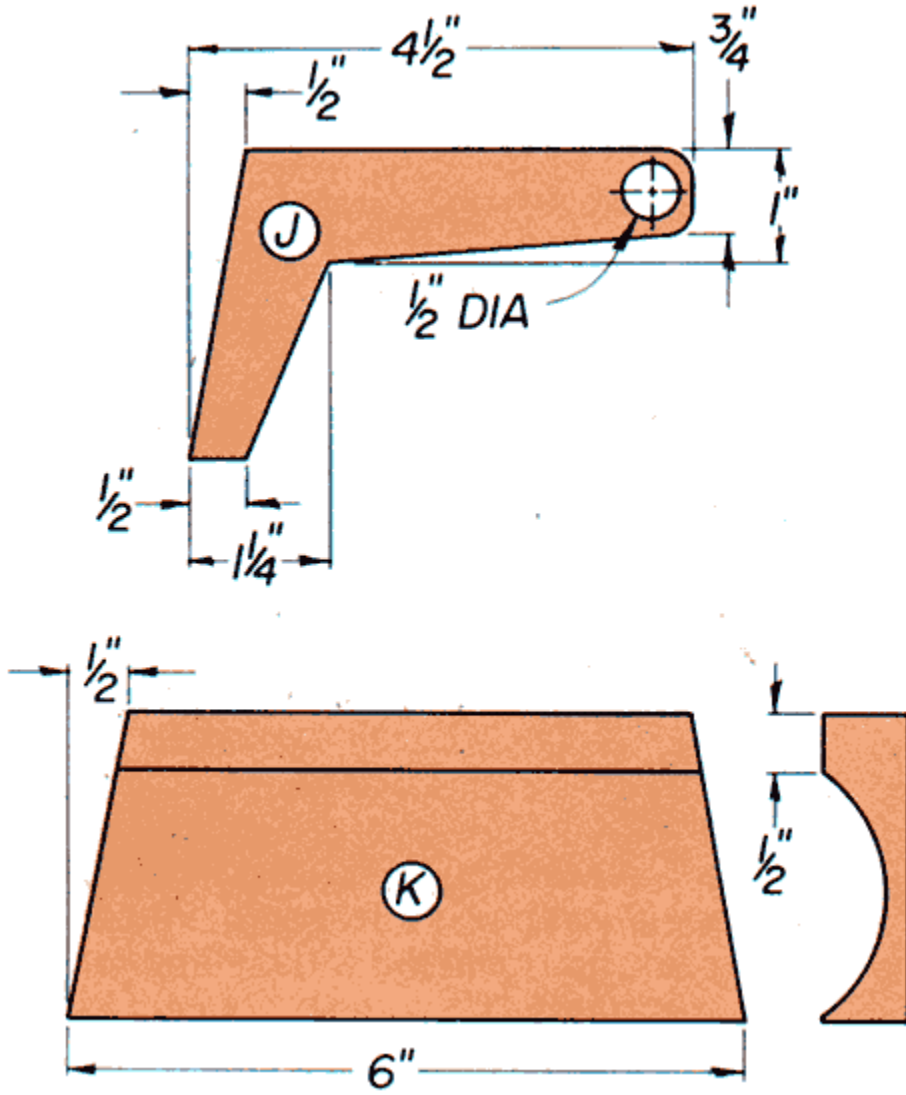

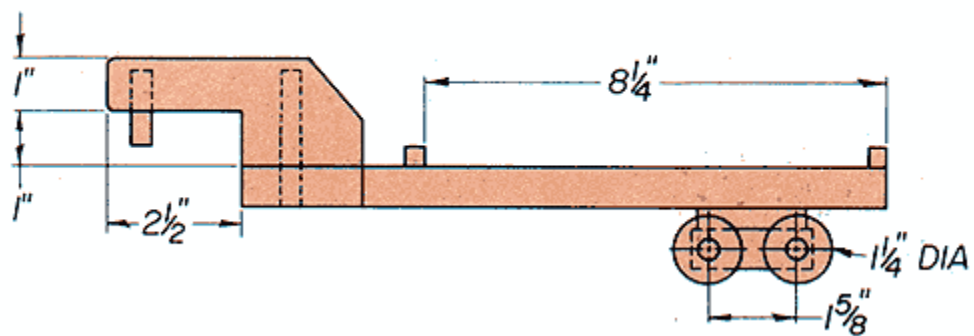
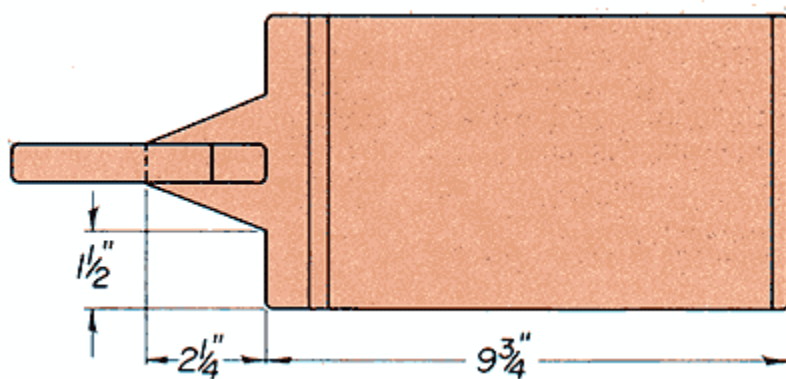
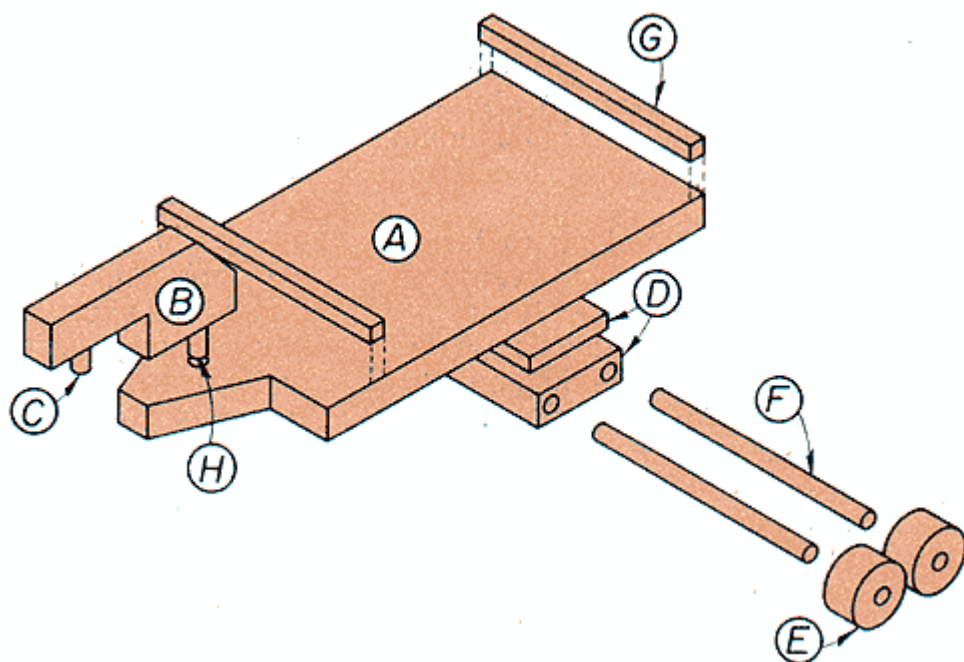

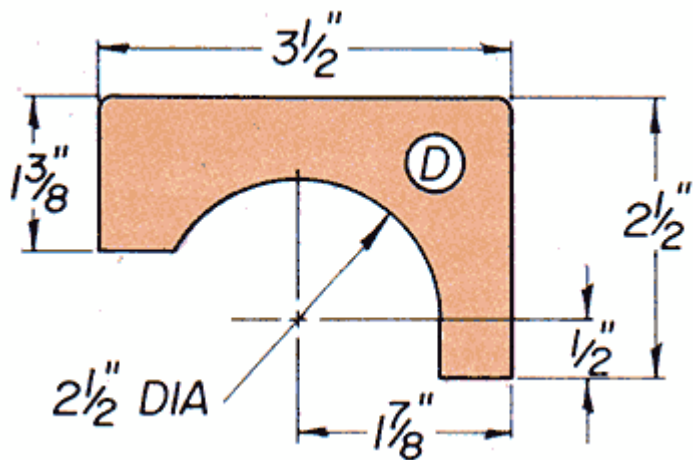
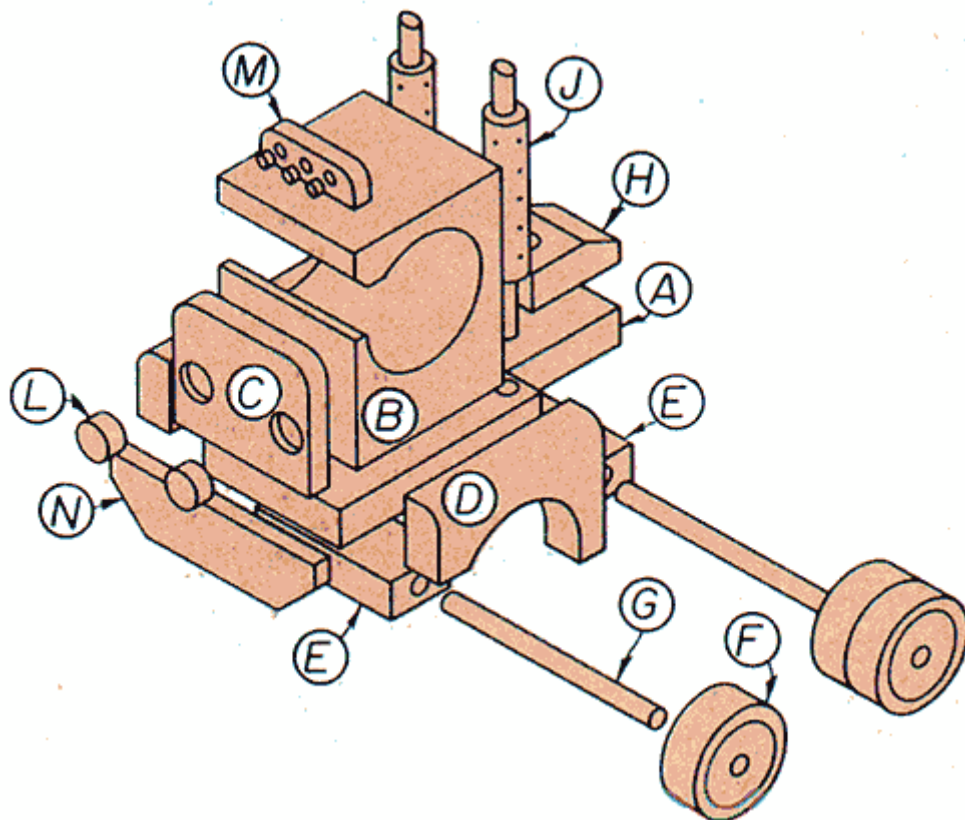

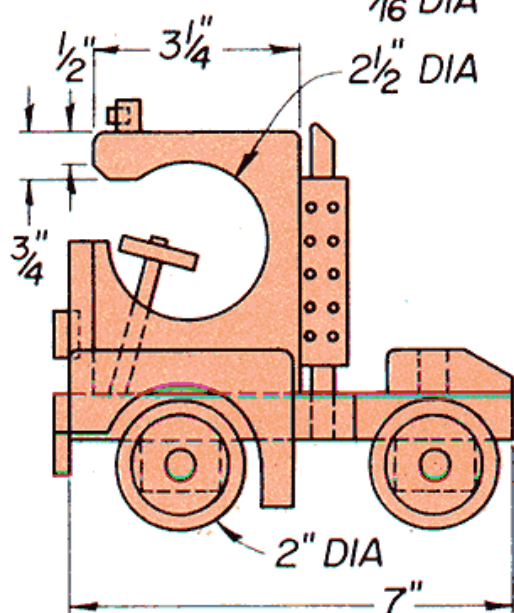
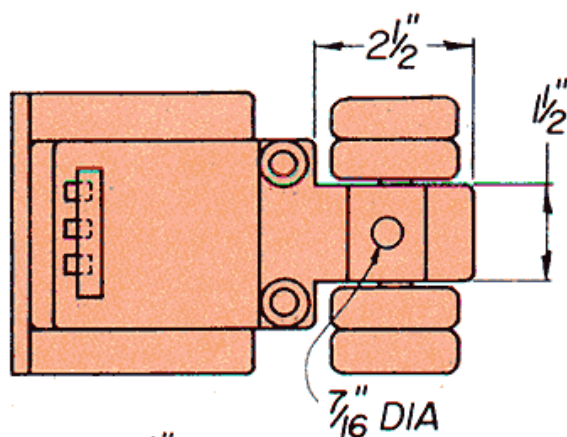
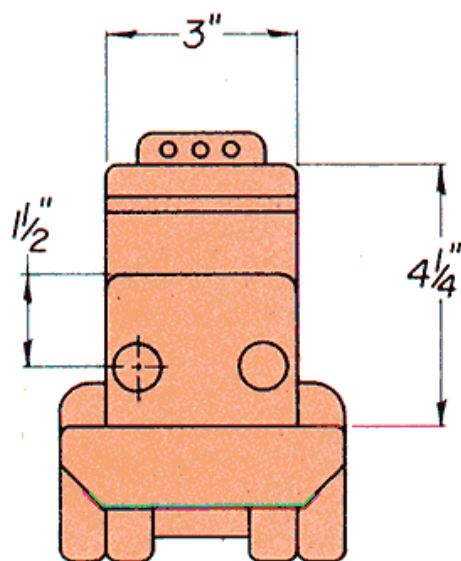

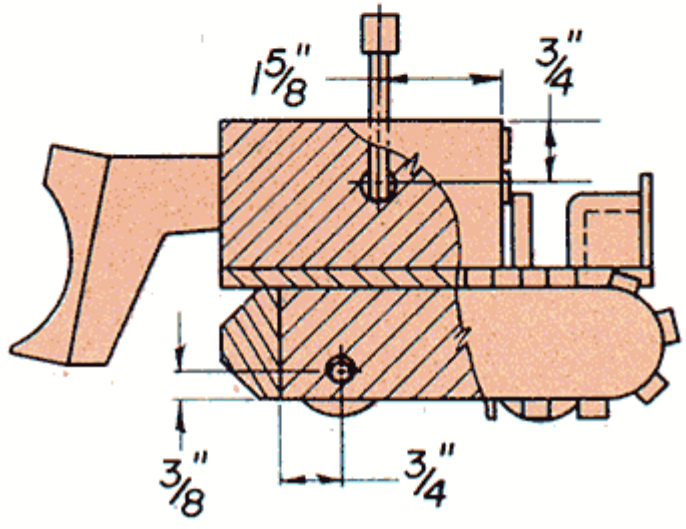
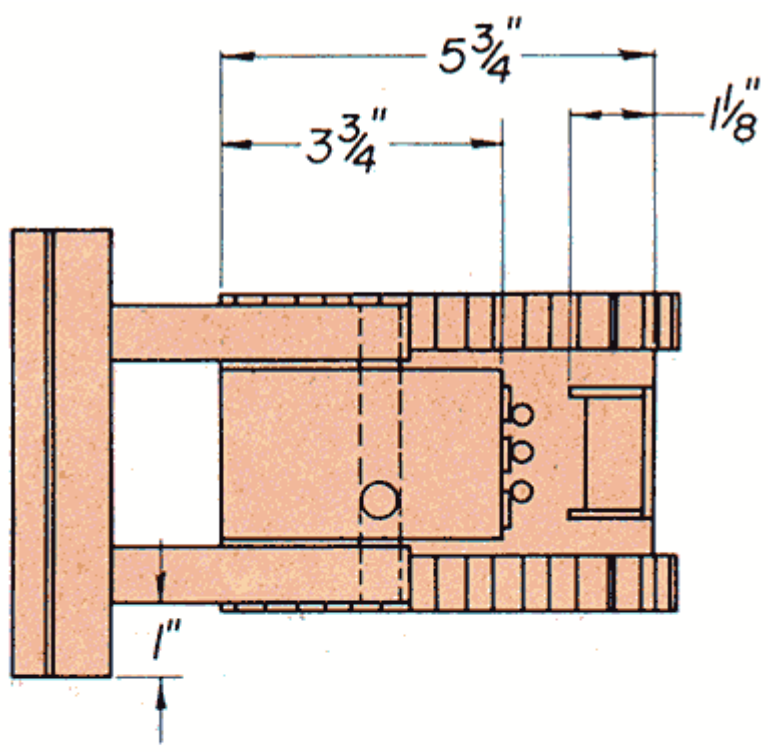

CLASSIC MANTEL CLOCK

Here's an easy-to-build, "bracket-style" mantel clock that's sure to fit in with virtually any room decor!



Mantel clocks are fairly simple to make and are universally well received as "heirloom gifts"...which makes them a great choice for Holiday gift-giving. Here's how we made ours:

1: Use your table saw, jointer and belt sander to cut, joint and sand all pieces to their final dimensions, as shown in the List of Materials.

2: Since all of the pieces of molding used in this project are relatively small in size, we believe the Router Table provides the safest way to handle cutting the required molding profiles. Here are a few important tips to keep in mind when using Router Tables:

If you're working with hardwoods, an electronic router motor speed control will help you slow down the bit sufficiently to avoid burning the work piece. If you don't have such a control, cutting your profiles in multiple passes will also help.

Make your end grain cuts first. This way, the subsequent long grain passes will clear up any splintering or tear-outs made by the end grain cuts. Good dust collection is especially important when using Router Tables, as any routing operation will throw dust and debris far and wide if you fail to take measures to collect it at its source.

Always feed your work piece against the rotation of the router bit...not with it, as making "climb cuts" with a router can result in dangerous kick-backs.



Whenever possible, use safety devices such as feather boards and push blocks or push sticks to keep your hands out of harm's way. Don't forget eye protection, as well.

3: Start by routing a 5/32" Roman Ogee on all four edges of part (C). Next, move to part (B) and make the indicated cuts with a 1/2" Cove Bit...followed by a 1/4" Straight Bit to make the small step at the top. Finally, use a 1/2" Round-Over bit and a 1/2" Cove Bit to cut the profiles in the top of part (A).

REMINDER: For the smoothest results, it's usually best to complete routed profiles in multiple passes instead of trying to make your cuts in a single pass.

4: The Clock Feet are made using the same basic techniques as the Upper Case Moldings. Use the following Router Bits: 1/2" Round-Over bit, 1/2" Cove Bit and 1/4" Round-Over Bit . This completes the molding operations.

5: Cut two oversize pieces of 1/4" plywood or masonite for the front (E) and back (G). Use contact cement to attach walnut veneer (H) to the plywood.

6: Use a 1/4" Straight Bit to rout a stopped groove in the front edge of parts (C). Also rout a groove in the front edge of parts (D). These grooves should be about 9/32" wide and 1/4" deep to accept the veneer-covered Clock Face (part E) when the Clock is assembled.

7: Next, use your Drill Press mounted Router set-up with a 1/4" Straight Bit to create 1/4" by 1/4" deep mortises in parts (C) -- to accept the 1/4" by 1/4" tenons you create on the ends of parts (D). This overhead set-up is preferred for operations such as this since it provides maximum visibility and safety while making your stopped mortise cuts.

8: Form the 1/4" by 1/4" tenons on the ends of parts (D) - to fit the mortises in parts (C). Dry assemble parts (C) and (D). When you're satisfied with the fit, put a 1/8" chamfer on the front and back edges of parts (D).

9: Dry assemble parts (C) and (D). Measure and cut the veneered plywood (E,G,H) to fit the assembled case frame (C,D)

NOTE: The back is different than the front because it must be hinged to provide access to the clock movement.

10: Dry assemble and clamp parts (A, B & C). Drill two 3/8" holes through parts (B & C) and one stopped 3/8" hole into the bottom of part (A). Insert a 3/8" dowel through these holes to help align these three parts during assembly and glue-up.



11: Glue parts (A, B & C) and clamp together until dry. Glue and screw the two feet (F) to the base (C). Once the top assembly has dried, drill two holes for the top handle (bail).

12: The Clock can now be final assembled. Glue and clamp the top, bottom, sides and front face together, being careful to keep everything square during assembly. Once the assembly has dried thoroughly, drill the appropriate-sized hole in the face panel for your clock movement.

13: Sand the assembled case thoroughly, vacuum the sawdust away, wipe with a tack cloth and apply the finish of your choice.

14: Install the movement, handle, back hinges and any decorative accents.

LIST OF MATERIALS

(finished dimensions in inches)

A	Walnut	3/4 x 4 x 11
B	Walnut	3/4 x 5-1/2 x 12-1/2
C	Walnut (2)	3/4 x 6 x 13
D	Walnut (2)	3/4 x 4-1/2 x 10-1/2
E	Plywood or hardwood	1/4 x 10-1/2 x 10-1/2
F	Walnut (2)	3/4 x 3-1/2 x 7
G	Plywood or hardwood	1/4 x 10 x 10
H	Walnut veneer	12 x 24

Clock Parts Sources of Supply:

Here are a few on-line sources for clock movements and parts.

Klockit
Lake Geneva, WI
1-800-556-2548
www.klockit.com

Clockworks
Westfield, MA
www.clockworks.com

Cherry Tree
Belmont, OH
1-800-848-4363
www.cherrytree-online.com



Murray Clock Craft
Willowdale, Ontario
1-800-268-3181
www.murrayclock.com
PM Clocks
Louisville, CO
303-665-3727
www.pmclocks.com

Front View

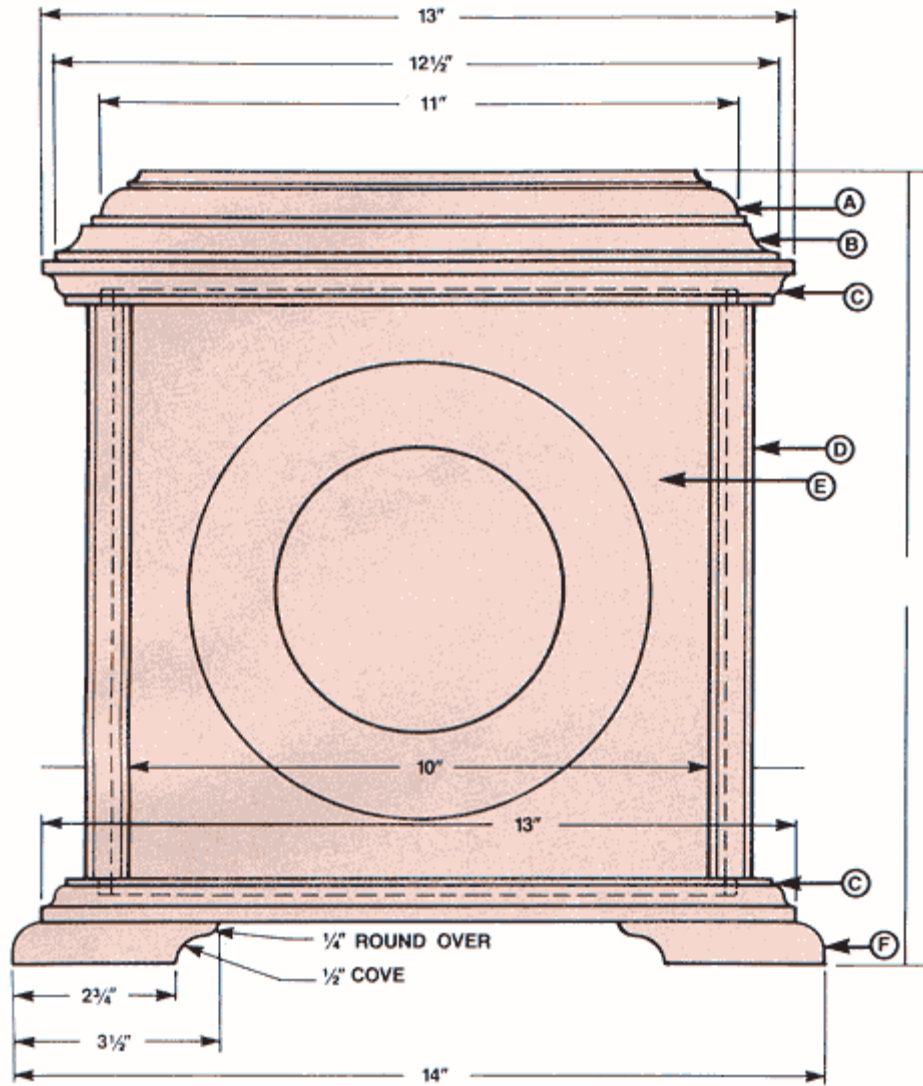

Side View

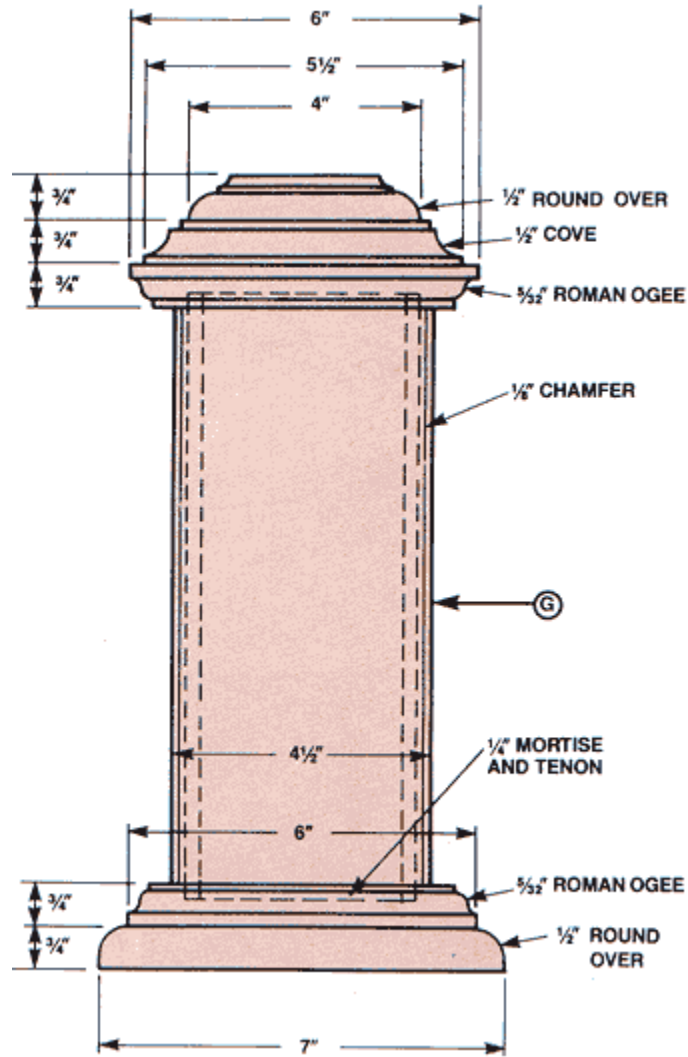



2004 Archive



KITCHEN DESIGN TIPS



It's often been said that "man cannot live without a kitchen". Whether it be a clearing with a campfire along a gurgling stream or the most modern, up-to-date kitchen imaginable, we depend on kitchens for our daily sustenance. It is for this reason that your kitchen is likely to be your most important - and most revealing - room in the house.

Kitchens help us satisfy our most basic human desire - SURVIVAL - and they have always reflected our lifestyles. During the "pioneer days", kitchens were set up in the backs of wagons, providing mobility as we marched Westward. Later, as pioneers became settlers, the kitchen became the focal point for many family activities. This was especially true during the Winter months, as it was often the only source of heat for the household. A study of an authentic early American kitchen would disclose some interesting details about the lives and lifestyles of its inhabitants.

As houses grew in size, kitchens began to reflect a more independent lifestyle. They were often set at the back of the house to isolate smoke and the smells of garbage while the home's occupants were busy elsewhere. In many cases, separate "Summer kitchens" were built apart from the main residence to contain the heat of cooking. In those days, kitchens were rarely visited by more than the cook, the iceman and the servants.

Today, we spend more of our waking hours in the kitchen than any other room in the house. As always, modern kitchens reflect our personal tastes and habits. So, if you're thinking about remodeling your kitchen, here are some guidelines to help you tailor a kitchen to suit you and your family's lifestyle.



Begin With An Evaluation

If you haven't already done so, you should start your re-design with a careful evaluation of your normal kitchen activities. Is there more than one cook in your household? Does your family gather here for three meals a day...or in a separate dining room? Is your kitchen well-trafficked - or perhaps too well-trafficked? Are your dining habits informal or formal? Do you have a regular dining schedule, or does it vary significantly from day-to-day? Do you do a lot of entertaining...with many people in attendance or just a few?

Don't forget to consider the appliances you'll need to make meal preparation convenient for you. Large capacity oven or small? What kinds of specialized countertop appliances will you need and how much space will you need to store them? Pasta-maker? Bread-maker? Toaster Oven? Now is the perfect time to plan for the accommodation of any new appliances you have been wanting.

As you evaluate your objectives and the resources you have to work with, your kitchen design should begin to come into focus for you.

The Work Triangle

As any expert will tell you, optimal kitchen efficiency depends on a *Work Triangle* composed of the three primary kitchen areas...the stove, the refrigerator and the sink. The total distance around this *Work Triangle* should be between 12 and 22 feet. Designers recommend 4 to 7 feet between the sink and the refrigerator; 4 to 6 feet from sink to stove or cooktop; and 4 to 9 feet from cooktop to refrigerator. Such a triangle arranges the appliances, countertop and storage spaces carefully to minimize travel around the kitchen during food preparation...and maximize efficiency.

This design process can be simplified by transferring your kitchen layout to graph paper containing 1/4" squares, with each square representing one foot. If you're planning to use this approach, we suggest that you also cut out scaled-to-shape appliances that you can move around from location-to-location on your layout without having to re-draw it.

An excellent alternative, of course, is to get your hands on one of the great, inexpensive computer software programs developed especially for kitchen design. They make easy work of creating an exciting and efficient design.

The Work Centers

Surrounding your work areas are three basic *Work Centers*: The *Clean-Up Center*, which is focused around the sink; the *Preparation Center*, which



includes the refrigerator, stove and adjacent countertop; and the *Serving Center*, focused around a separate area of countertop.

Ideally, in a single cook kitchen, you should have 48 inches of walkway between opposing *Work Centers* - 54 inches in a two-cook kitchen. And, since the sink is the least mobile of all kitchen "appliances", it's best to start your planning process with the *Clean-Up Center*. The most important consideration here is **counter space**. For right-handers, designers typically recommend 36 inches of counter space to the right of the sink, 30 inches to the left...and that the dishwasher be placed to the **left** of the sink. To make loading and unloading convenient, china and silverware storage should be in close proximity.

The *Preparation Center* should allow the refrigerator door to open **into** the *Work Triangle*. Approximately 4-1/2 feet of counter space is necessary, preferably including a surface for cutting or chopping. And, since small, countertop appliances such as food processors, blenders, mixers, toaster ovens, bread makers, can openers, etc. will be used here, an adequate number of GFI (ground fault interrupt) electrical outlets should be nearby. Now is also the time to consider special storage "garages" for these small appliances.

Be sure to locate the *Preparation Center* near the sink. This is particularly useful for slicing, cutting and peeling operations. Keep this in mind: It is highly inefficient to locate the refrigerator next to the range. Since the range dissipates heat, it will interfere with the cooling efficiency of the refrigerator. Gas ranges should be located away from windows where flames could be extinguished by breezes...or worse yet, set fire to billowing window curtains.

The *Serving Center* needs a **minimum** of 2-feet of counter space, including a "landing area" of heatproof material for sitting pots and pans that have just come from the cooktop or oven. Nearby storage space should be provided for pots, pans, cooking utensils, serving dishes and possibly, table linens.

With these three *Work Centers* in mind, you might also consider a kitchen island. If mobile (with the simple addition of casters), these *islands* can add extra counter or storage space where needed. If stationary, they can even include a cooktop, sink or additional eating area. Kitchen *islands* cut down on cross-traffic and serve to "tighten" the *work triangle* for improved efficiency.

Additional Work Centers

Additional *Work Centers* for baking, serving drinks or buffet-style serving may also be worthy of your consideration. The most common of these is an in-the-kitchen eating area. Often surrounding a kitchen *island*, such *eating*



centers greatly simplify meal serving. A peninsula or protrusion countertop can also make a convenient eating area. But, be it an *island*, peninsula or protrusion, make sure you allow at least 24 inches of countertop "elbow room" between diners. The standard height for this area is 36". For breakfast-only dining, a minimum depth is 15". If you think you'll be using this area for more than one meal a day, you should consider increasing this depth.

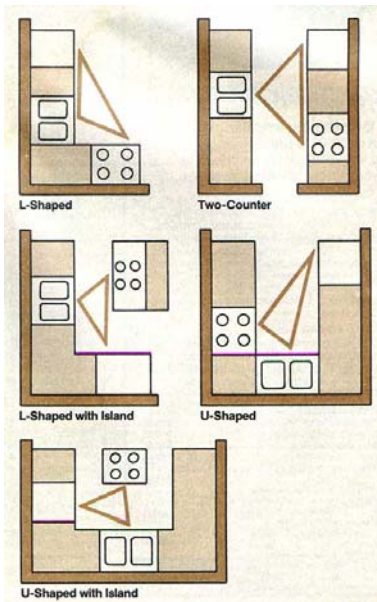

By varying the placement of the three primary kitchen areas and experimenting with peninsulas, protrusions and islands, you can easily adapt the basic kitchen floor plans shown here to create numerous possibilities. The Work Triangle concept will easily conform to all but a single-counter design. Click image for larger view.

Cabinets & Countertops

Whatever your kitchen design, the cabinets will probably represent your largest investment. Designers stress that you should try *not* to skimp on cabinet space. At least 10 linear feet of base cabinets and 10 feet of wall cabinets should be provided in *all* kitchens. And, since cabinets will occupy the majority of your wall space, they will largely determine the decor of your kitchen. As a result, you should choose the style of your cabinets wisely.

Custom cabinets offer the most flexibility, and you'll discover that building them yourself will cost you about **one-fifth** of what you might expect to pay for professionally-built, custom-made cabinets. That's a substantial savings! What about cabinet materials? Wood, of course, is the most popular and



offers a variety of strengths, grain patterns and colors. Plastic laminates consist of several sheets of heavy paper, the top sheet usually covered with a wood grain print then coated with a layer of heavy, transparent plastic.

Countertops can be made of wood, plastic laminate, concrete, granite, marble, tile, metal or virtually any durable material. Wood adds warmth to kitchen countertops. However, unless it's coated properly, it will easily stain, cut and harbor bacteria. "Butcher Block" countertops should be rubbed frequently with salt...or coated with a non-toxic finish such as Salad Bowl Finish or Preserve Oil Finish.

Adding More Space

Many contemporary architects have combined kitchens with living and recreation areas, to create large "great rooms", designed to accommodate a variety of family activities. Such a concept provides the luxury of a large kitchen, although your appliances may only occupy a small portion of this space. If you have a tiny kitchen and have considered opening it up into a "great room", you may be tempted to knock down a wall. Just remember to check your house plans before you do so to make sure the wall you want to eliminate is not a "load-bearing" wall.

If you want to open things up a bit, but would prefer not to knock out a wall, there are several options. For example, skylights provide the illusion of more space, as does opening-up a ceiling all the way to the rafters. If your kitchen has a South-facing wall, consider building an attached, lean-to greenhouse. Besides adding more space, these greenhouse additions offer two additional advantages: Properly designed, they can shave a substantial amount off your Winter heating bill - plus - you can use them to grow some fresh vegetables, an herb garden or even miniature fruits, all year long.

Rebuilding or remodeling a kitchen may require building, electrical, plumbing or other permits, depending on the building codes in your area. We suggest that you contact the building department in your community or the Department of Housing & Urban Development in Washington for more specific information.

Today's kitchens can be anything you want them to be. Dining rooms, family rooms, greenhouses or perhaps nothing more than a sink, stove, refrigerator and a small amount of counter space. But whatever shape your kitchen takes, it is likely not to be determined merely by your need to survive. Replacing the kitchens of the past (campfires, open hearths, chuck wagons and separate "Summer house" kitchens) are the kitchens of today...and those of future...all, specifically tailored to your lifestyle. Convenience,



preference and most of all, "personal flavor" now season the room which has, for centuries, provided us all with "our daily bread".

Above all else, your cabinets set the style for your entire kitchen. No matter what appliances, curtains, floor or wall coverings you choose, it's the cabinets that will ultimately dictate the "style" of your kitchen. That's because they're the most visible, and thus the most *important* element to consider when you design or remodel your kitchen.

And, it's really the cabinet *doors* and *drawer fronts* that most express this style. Because of their importance, making new cabinet doors is probably the easiest way to remodel your kitchen. Change these doors (and drawer fronts) and you've changed the kitchen decor. It's that simple!

Most cabinet doors are made in one of two ways: Either as a solid board front...or as a frame-and-panel style. Unless you decide to build from veneered particleboard or MDF, you run a great risk of a single-board door warping eventually - even if it's made of plywood. That's why all of the doors we've made here are of frame-and-panel construction.

Making The Frame

Door frames are typically made from four pieces: two vertical *stiles*, a top *rail* and a bottom *rail*. A rabbet on the inside edges of all four pieces holds the *panel* in place. When constructing frame-and-panel doors, there are a variety of ways to join the *rails* and *stiles* together. You could use biscuits or dowels...you could use half-lap joints...or you could use the longest-lasting joint of all (and the least likely to sag), the mortise-and-tenon joint.

Start by determining the final size of your cabinet doors. This will depend on the way you want to hang them. You can either choose to insert them completely inside the cabinet frame -- cut a *lip* around the door edges so they're partially inset - or do neither, allowing the doors to completely overlap the door opening.

If you're planning to inset them, be sure to make them 1/16" smaller in height and width than your opening to allow for clearance. The easiest way to do this is to make them the same size as your opening, then use your Jointer (set to take a 1/32" cut) to *shave* them down to the final desired dimension.

If you want them to partially or completely overlap your door opening, make them 1/4" to 3/8" larger than your door opening, all the way around.



Start by cutting the *rails* and *stiles* to size. Usually, these are 3/4" thick by 2" wide, except for the top *rail*. That's because, in two of the doors we've built here, we made our top *rails* slightly wider so we could cut a simple curve in them with a Bandsaw. This curve will not interfere with the joinery.

Next, cut a 1/4" deep by 5/16" wide rabbet on the inside edges of your *stiles* and *rails*. You could either use a Dado set-up...a Router Table with a straight bit...or a Shaper set-up with a 1" Blank Cutter and a 1-1/4" Shaper Collar. The Dado method is probably the easiest for straight-sided stiles and rails, while the Shaper or Router set-up will cut a smooth rabbet in either the straight or curved edges.

Use a Hollow Chisel Mortising set-up with a 3/8" Chisel to cut a 2" long by 3/4" deep by 3/8" wide stub mortise in both ends of each stile (See fig. 1). These will mate with the tenons formed in each end of your rails. Of course, if you've chosen one of our curved-top door styles, your top mortises may have to be longer or shorter than 2".

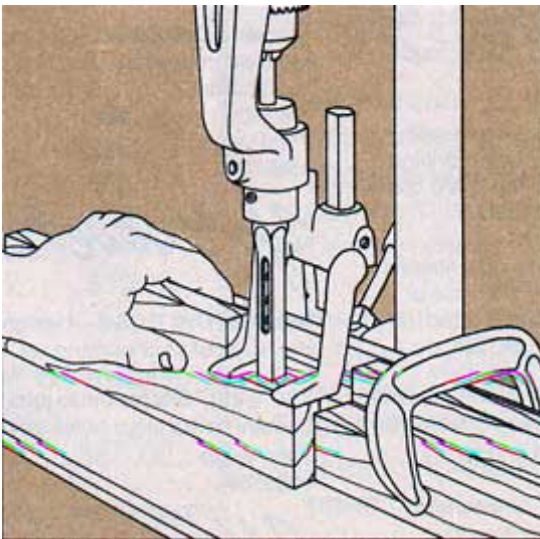

Now, using your Dado set-up with a Tenoning Jig...or a Molder set-up with a Blank Cutter, form the tenons in the ends of your rails. These tenons should be 3/8" wide by 3/4" long on the front side and 7/16" long on the back side (See "Corner Joint Detail" drawing). Assemble the frames with glue and set aside to dry thoroughly.

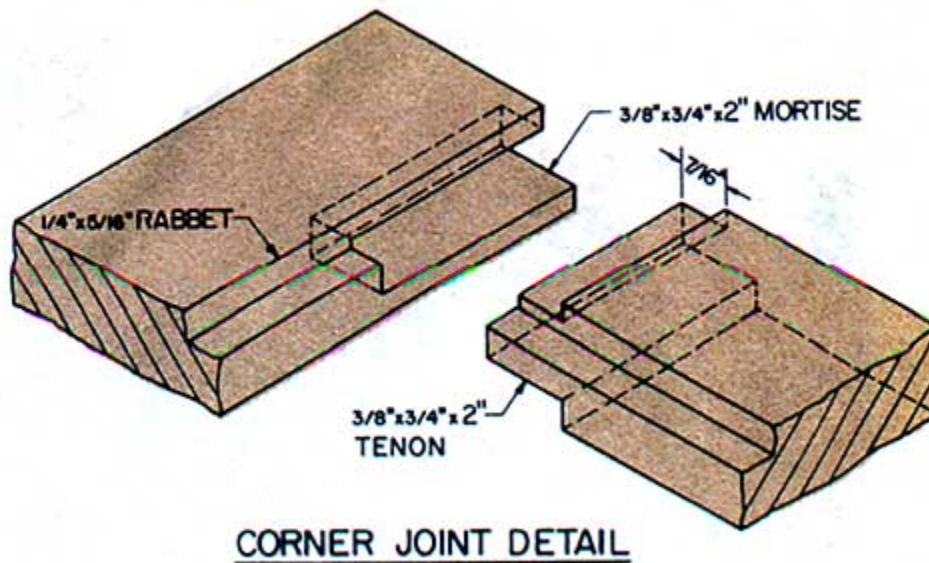

Making The Panels

When making the panels, you have a wide variety of materials from which to choose. These include not only different woods, but other materials such as copper, brass, tin, enameled steel, hardboard, plastic or glass. Most of these materials can be easily machined on your MARK V to create a variety of styles. Here are just four possibilities;

Raised Panel

Depending on the height and width of your doors, you may have to glue-up stock, edge-to-edge, to create the large panels you'll need. Make sure that the end grains "cup" in the same direction, and never dowel the panel stock together, since dowels could split over time. Joint all edges, then use a Glue Joint Cutter with your Molder or Shaper to assemble your door panels (See Fig. 2). When making wood door panels, always be sure to cut the panels slightly smaller to give the wood room to expand and contract without splitting as the humidity and temperatures of the environment change. Otherwise, your panels could split the frames on hot, humid days.

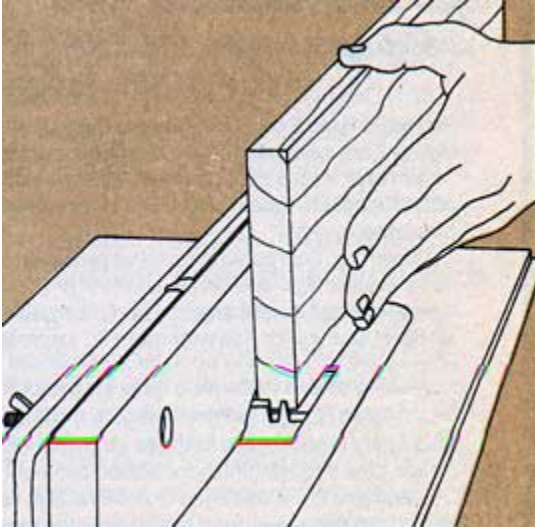

To determine how much “play” you should provide for your panels, first determine its critical dimension. Remember that wood expands 10 times more across the grain of the wood than it does with the grain. So, if you run the grain of your panel vertically, the critical dimension will be the width of the panel. If you run the grain horizontally, your critical dimension will be the height of the panel.

Once you've found this dimension, apply this rule of thumb: If the critical dimension is under 12", allow a total of 1/8" of play (1/16" all the way around). If the critical dimension is over 12", allow a total of 1/4" (1/8" all the way around).

Once you've cut your panels, tilt your MARK V's Worktable to 15-degrees, turn your panel on edge and use a Hollow-Ground Planer Saw Blade to cut a bevel all the way around the panel's edges. Adjust your Rip Fence and the height of the Worktable so that the Saw Blade leaves a 1/8" step between the raised surface and the bevel...and so your bevel tapers down to a 3/16" thickness at its outside edges (See Fig. 3). A panel-raising jig can simplify and bring added safety to this task.

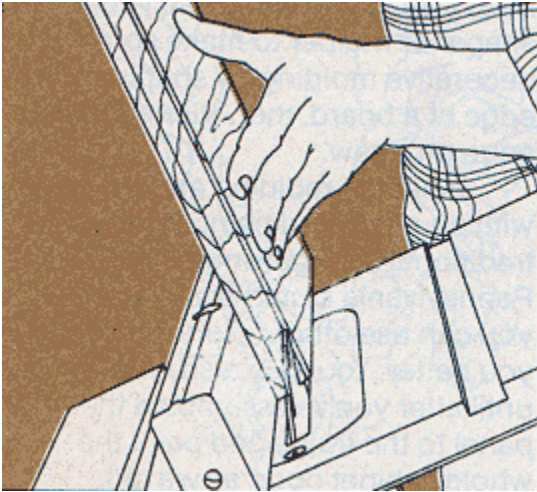
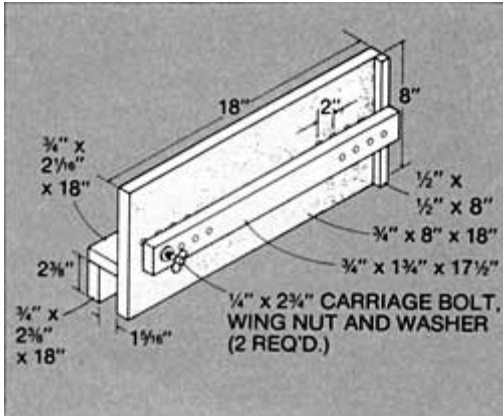

Fancy Panel

As with the raised panel, glue-up your stock and cut it out, slightly undersized. Set up your MARK V to shape, then select a cutter (or combination of cutters) that will produce the fancy edge you like best. We used the Combination Quarter-Round Cutter to create the panel shown in Fig. 4.

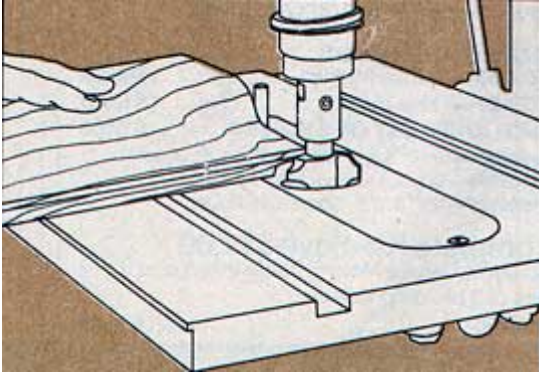

Mount the Cutter on the Shaper with the 1-1/4" Collar and make your first pass, cutting all the way around the edges of the panel. Adjust your depth-of-cut so that the shaper leaves a 1/4" thick tenon on the edge. Change to a 3/4" Collar and make a second pass. By using progressively smaller Collars, you'll avoid "hogging" (taking too big of a bite in a single pass).

After your second pass, the tenon should be about 3/8" wide - wide enough to mount the panel in your rabbeted frame and show off your fancy edging. Additional decorations can be cut in either the edge or the surface of your panel by making additional passes with other Shaper or Molder Cutters.

Decorative Metal

Early settlers used punched sheets of tin and copper much like we use screen. The holes in the metal allowed the air to pass in and out of furniture such as "pie safes", but not the little "critters".

To reproduce this effect, purchase sheets of copper, brass or tin that are approximately 1/64" thick. Tin (these days, it's actually rolled steel) is by far the least expensive. It's also quite versatile. By rubbing it down with gun bluing, it will take on a blue-brown sheen. Paint it flat black and rub it with *Rub 'N Buff Gold*, and it will take on a coppery sheen. There are several different antiquing and gilding kits available at crafts stores that could be used to achieve different effects on tin.

Start by making a full-size pattern out of paper and attach it to your metal with rubber cement. Punch holes where desired with a nail or an awl to create your pattern. Or, you could do what we did...take an old center punch and use your Disc Sander to grind its tip to a square (like a typical nail) point to make the process of punching safer and easier (See Fig. 5).

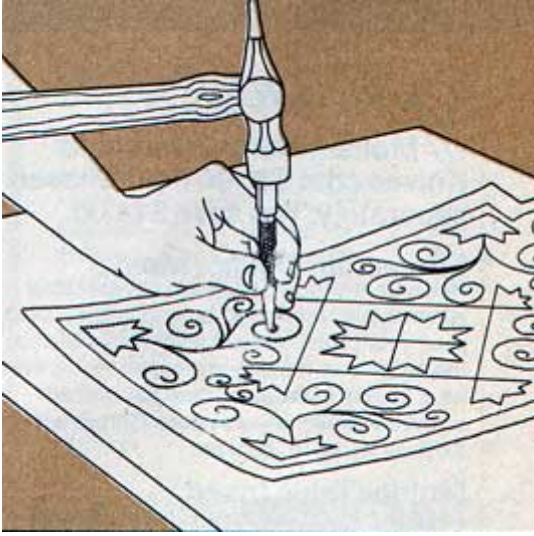

Remember that the punching may cause your panel to buckle or curl. Don't be alarmed. When you've finished punching your holes, just bend it straight again. Buff the surface with #0000 steel wool and cut to size.

Pennsylvania Dutch

Cut a piece of 1/4" thick tempered hardboard to size. If you like, use your Shaper or Molder to make some decorative molding by shaping the edge of a board, then simply ripping that shaped edge off your board using your Table Saw.

Paint that molding and the panel with enameled paint. White is the traditional color for Pennsylvania Dutch designs, but you can use other colors, if they suit you better. You may also wish to wait until after you've assembled the panel into the frame and paint the entire cabinet door at once, as we did.

Once the enameled paint has dried, lightly pencil a design on the surface. There are probably several books on Pennsylvania Dutch designs available at your local library, if you need ideas. Then, with either acrylic or oil paints, color in your designs.

Mounting The Panel To The Frame

When mounting wooden panels to the frames, **don't** glue them in. As we mentioned before, the wood panels need room to expand and contract with changes in the environment. The easiest way to provide this room is to mount the panel in the frame with four #8 x 5/8" long roundhead screws and washers. Position these screws a few inches left and right of center at the *end grains* of the panel...giving the critical dimension (across the grain) as



much freedom as possible. Drill oversized 7/32" pilot holes for your screws to allow for movement. Metal, tempered hardboard, plastic or glass panels can be attached with glazing points or with screws (except glass panels, of course).

Finishing and Installation

Stain the doors to match the cabinet frame, if desired. Then choose a waterproof finish that cleans up easily. We recommend either tung oil or polyurethane. Tung oil will give you a soft, natural finish and bring out the grain of your wood. Polyurethane will give you a deeper, glossier look. Either will wear well.

Clamp or wedge the doors onto the cabinet frame in position and drill for hardware. Attach the hinges, catches and pulls, then stand back and admire your work.

You'll be amazed how one simple project...new cabinet doors...can give your entire kitchen a new look!

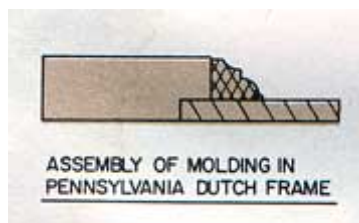
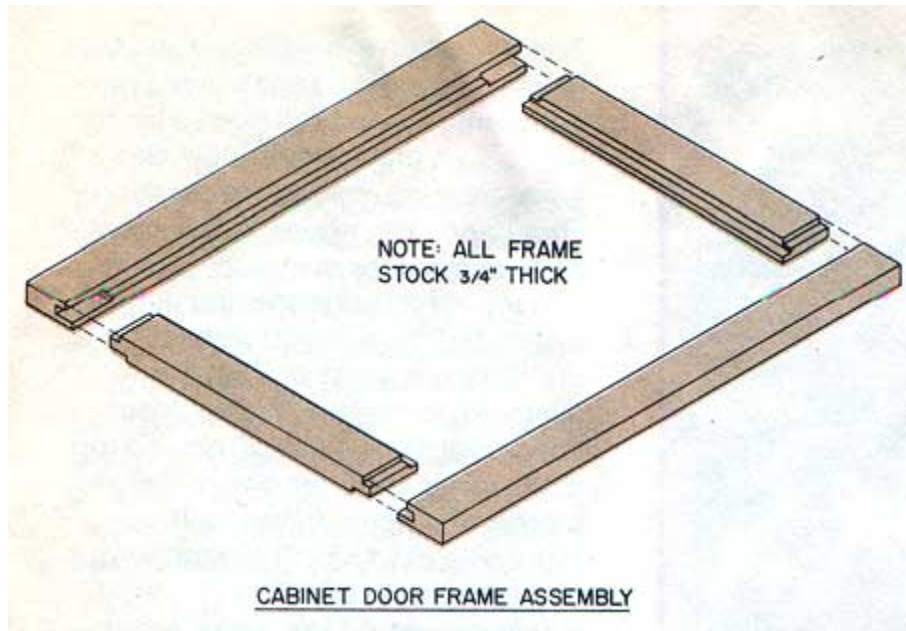

Pennsylvania Dutch Pattern



Punched Tin Pattern

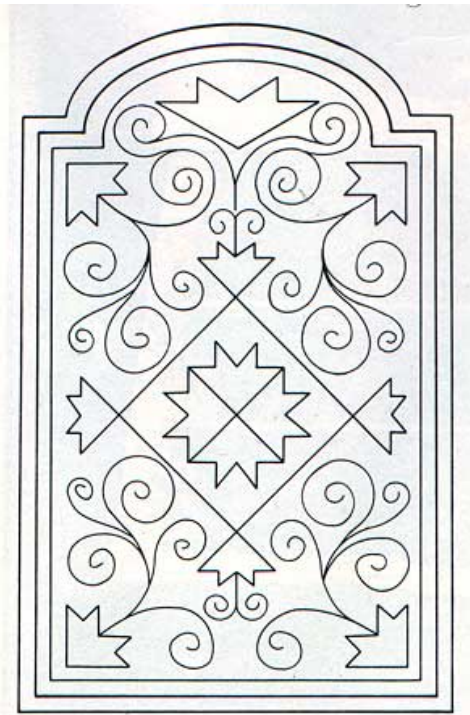

KITCHEN UTILITY RACK PLUS



The Utensil Rack

Most modern kitchens are small, so space must be used wisely. Here's a great space-saving idea -- a utensil rack to hang pots, pans, spoons, etc. so they're out of the way, yet convenient when needed.

Start by cutting all the required Rail and Batten pieces to size from 3/4" thick stock. Make them whatever length you desire. Next, cut your dowels to length from 3/8" and 3/4" dowel rod.

Use a 3/4" diameter bit to bore the dowel rod holes 2" in from each end of your horizontal Rails. Clamp a block of wood to your Rip Fence to ensure the exact same positioning for each hole.

Next, tilt your Worktable 15-degrees and use a 3/8" Bit to drill the angled holes for your 3/8" diameter Dowel Pegs.

Lay the Rails on top of the Battens with a removable, 3/4" scrap wood spacer block between each Rail. Mark and bore the mating 3/4" dia. dowel holes in the Battens. Also, bore the screw holes in the back of the bottom Rail - and countersunk holes in the Plexiglas panel for assembly.



Sand all pieces. Assemble the Rails to the Battens with dowels and glue. Glue your Dowel Pegs into your angled holes. Finish the Rack with an oil and water-resistant finish such as polyurethane or tung oil. Attach the plexiglas panel to the back of the Battens to keep pans from marring your walls. Bolt the finished Utensil Rack to the kitchen wall.

The utensils hang from the Wire Hooks, which in turn, hang from the Rails. Make the Hooks by bending 1/8" steel or aluminum rods. Use pliers to form square corners to fit over the Rails, and bend the opposite end around a 1" diameter pipe to form the Hook.

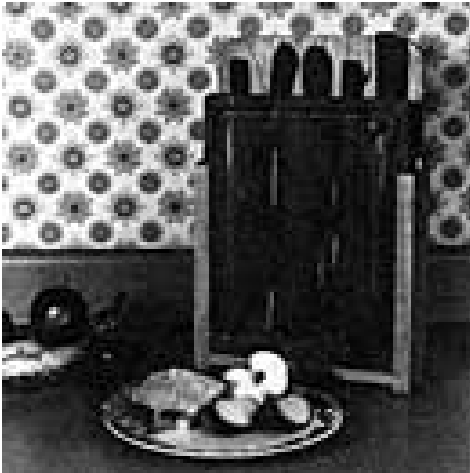

The Knife Block/Cutting Board

Whether you're slicing, cutting, carving or chopping, you'll be using a knife and a cutting surface of some sort. And since these two items are such an essential combination, we decided to put the two together into a single, universal project.

Start by using your Bandsaw with a 5/8" Resawing Blade to resaw your stock to a 1/2" thickness, then glue up the wider panels you'll need for the Back and Bottom pieces.

NOTE: If you prefer, you can also make these pieces from 3/4" thick stock. However, the finished project will be heavier for wall-hanging. While you're at it, glue-up the stock for the Knife Block and Cutting Board. Be sure to use waterproof glue when assembling the components of this project. Allow your glue-ups to dry thoroughly, then cut all pieces to final dimension and sand smooth.



Using a Router set-up or Dado Blades, cut the required joinery in the Sides and the Knife Block. If you decide to use your Dado Blades, you'll have to do some hand work with a chisel where the 3/4" groove meets the 1/2" dado on the side (see exploded view). With a sander, round the corners on the Back, Sides and Cutting Board. Cut knife slots in the Knife Block with either a Bandsaw or a handsaw.

Assemble the Knife Holder with waterproof glue and set it aside. Using a 3-In-1 or core box router bit, rout a juice trough around the perimeter of the Cutting Board, as shown in the drawing. You can taper the depth of this trough by tacking or double-stick taping a 1" wide x 1/8" thick strip of scrap wood to the bottom side of the Cutting Board...nearest the edge where you want the trough to be deepest. Using Shoppersmith's overhead Routing Set-Up, rout the trough as you normally would, then remove the thin piece of scrap wood. Your trough will be evenly tapered.

Slide the Cutting Board into the 3/4" groove in the Knife Holder. If it sticks, sand or joint a little stock off the edges. Finish with Salad Bowl Finish.

LIST OF MATERIALS - Utensil Rack

(finished dimensions in inches)

Battens	(2)	3/4 x 1-1/2 x (selected length)
Rails	(x)	3/4 x 2 x (selected length)
Dowel Pegs	(10)	3 x 3/8 dia.
Dowels	(2 x # of rails)	1-1/2 x 3/4 dia.
Plexiglass	(1)	Sheet, 1/8 x (determined width) x (determined length)

Hardware

#10 x 3/4" Roundhead Wood Screws & Washers (2 each) To attach Plexiglass

1/8" dia. Steel or Aluminum Rods (selected number) To make hooks
 Moly Anchors or other Hanging Hardware (4)



LIST OF MATERIALS - Knife Block/Cutting Board

(finished dimensions in inches)

Knife Block	(1)	1 x 1-3/4 x 9-3/4
Back	(1)	1/2 x 9 x 17
Sides	(2)	3/4 x 3-1/4 x 11-1/2
Bottom	(1)	1/2 x 2-1/2 x 9
Cutting Board	(1)	3/4 x 9 x 13-1/4

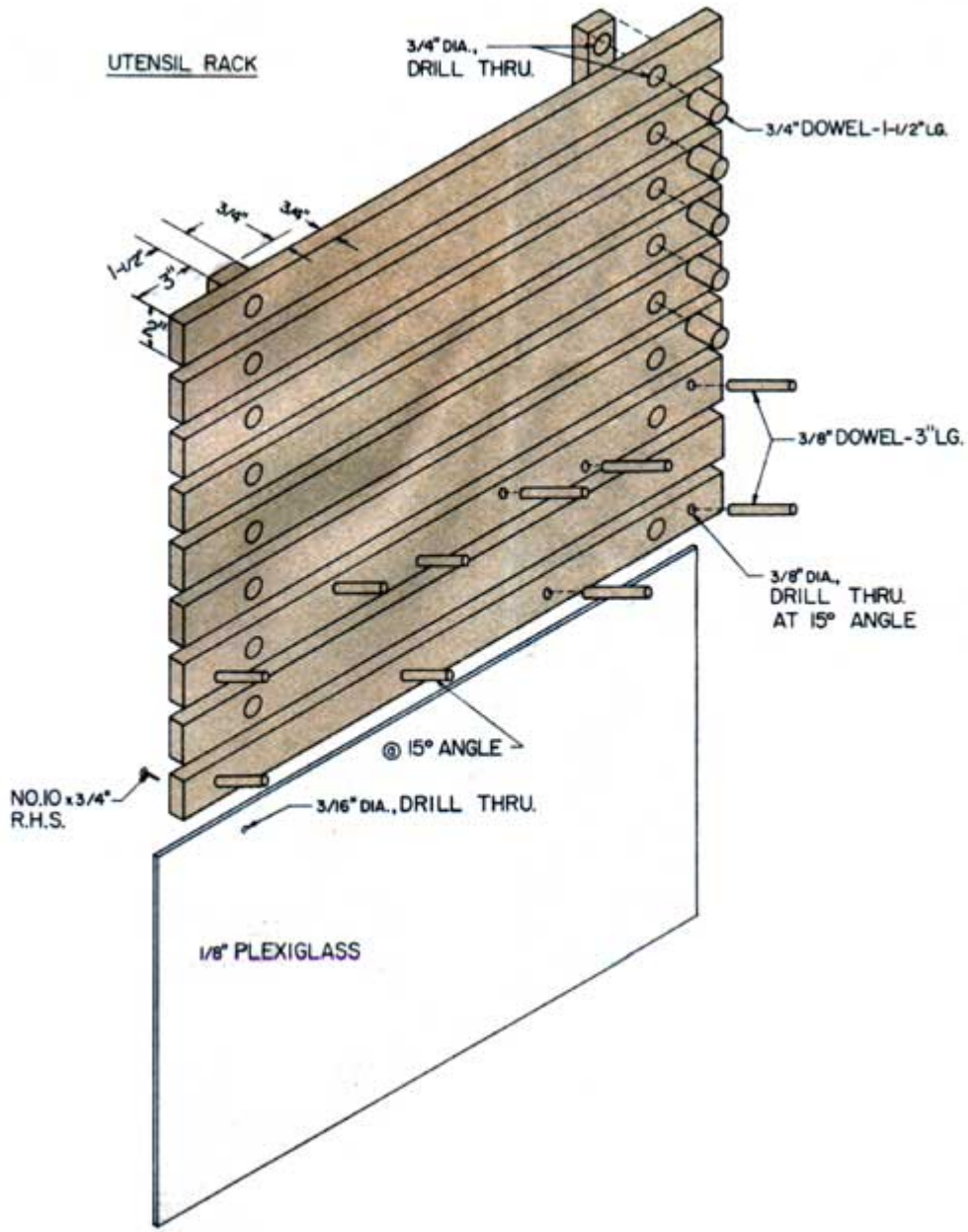

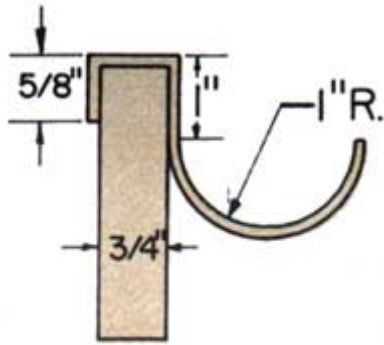

HOOK DETAIL

GALLERY RAIL PAPER TOWEL HOLDER

Here's a quick, easy-to-make paper towel rack that's unlike any you'll find elsewhere



This Towel Holder turns a plain roll of paper towels into an attractive point of interest in any kitchen. Plus...it's both easy to build (thanks to the readily available gallery spindles) and quick to sell at craft fairs, festivals and similar events.

We used maple and cherry to build our project, but you can build yours from any wood you like. Walnut or cherry will command a higher price than fir or pine, as an example.

Cut the Top (A) and two Sides (B). Cut one piece 3/4" x 2-1/2" x 15" to make the Rail parts (C & D).

Glue and clamp up (if necessary) the material for your Roll Pins (E). Use your Shopsmith Shaper set-up (with the Cutters of your choice) to shape the two sides and front edge of the Top (A) and both sides of the 2-1/2" x 15" piece mentioned in the above paragraph. Once the edges of this piece are shaped, rip it in half on your Table Saw, making two 1-1/8" wide strips, 15" long. These strips will be used to make the Side Rails (C) and Front Rail (D).

Miter the Rail parts (C & D) to size and cut out the spline grooves where the miters meet. Make the required splines, then glue and assemble the Rail parts together.

Locate and drill the holes in the Sides (B) for the Roll Pins (E) and Bullet Catches [be sure to drill from the **backs** of the Sides (B)]. Cut and sand the radii on the two Sides (B).

Locate and drill the holes in the Top (A) and assembled Rail for the Gallery Spindles. Drill and counterbore for screws to assemble the Top (A) and Sides (B).



Using your lathe, turn the Roll Pins (E) to your desired shape, then finish sand them while they're still on the lathe.

Glue and screw the Sides (B) to the Top (A) and plug the screw holes. Glue and assemble the Gallery Spindles, Top (A) and Rail assembly (C & D) together.

Finish sand the project and apply the finish of your choice. Install hangers for attaching it to the wall and insert the Bullet Catches from the inside of the 1-3/8" hole, pressing them into place. Friction should hold them securely. Suggested retail price: \$35 to \$50 each - depending on wood used and finish

LIST OF MATERIALS

(finished dimensions in inches)

A	Top (1)	3/4 x 6-1/4 x 15-1/2
B	Sides (2)	3/4 x 5-5/8 x 6-1/4
C	Side Rails (2)	3/4 x 1-1/8 x 5-7/8
D	Front Rail (1)	3/4 x 1-1/8 x 14-3/4
E	Roll Pins (2)	2" O.D. x 3-7/8 long

Miscellaneous

- (2) Splines 1/8" x 3/4" x 1-5/8"
- (9) Gallery Spindles
- (2) 3/8" dia. Bullet Catches
- (4) #9 x 1-1/2" flathead wood screws
- (2) Hangers
- (4) 3/8" dia. Wood plugs

Front View

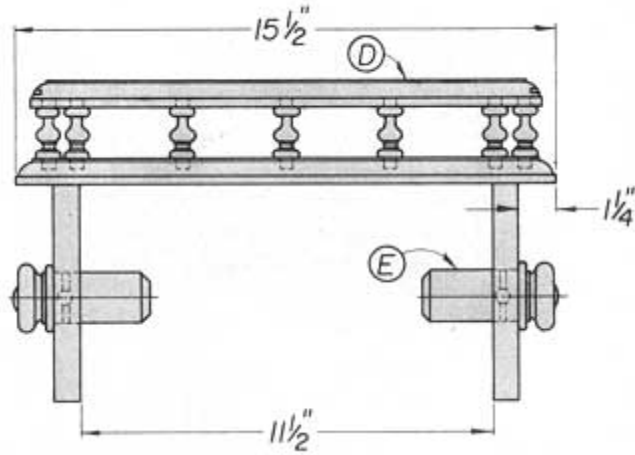

Side View

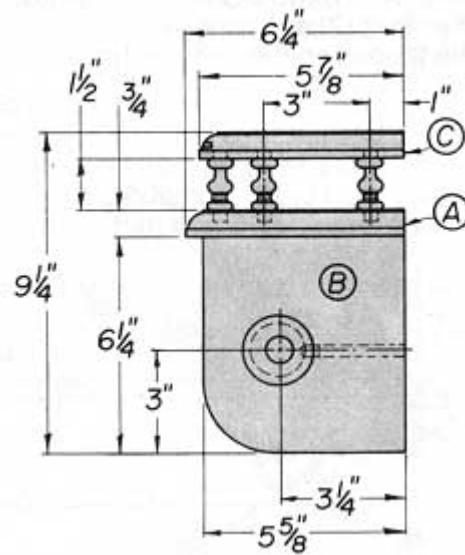

Spline Detail

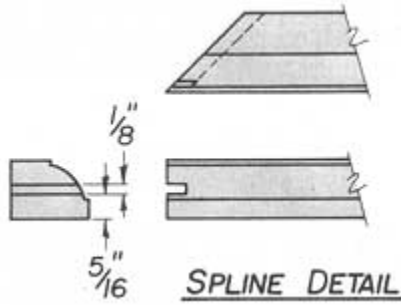

Bullet Catch



Pin Layout

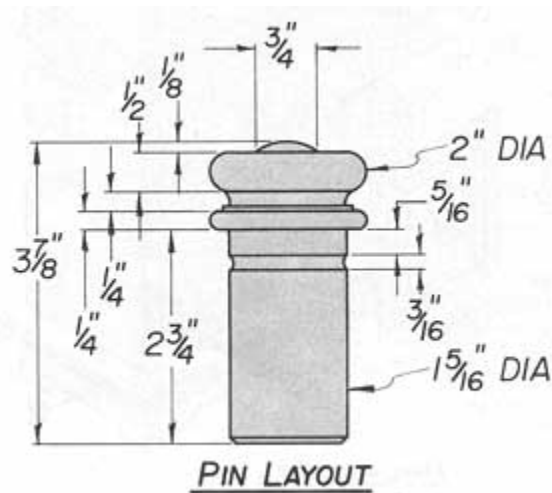



TURNED HALL TREE

A great weekend project to help build your woodturning skills



Here's a relatively simple project that doubles in function and beauty. Build it this weekend and you'll soon have additional "closet space" - PLUS - a classic, traditionally-designed "piece of furniture" that blends well with practically any decorating scheme.

All you'll need are one 4" x 4" x 8' and one 2" x 4" x 6' pieces of lumber plus eight dowel pins and two double-ended dowel screws. That's it! We used redwood for its natural rich color and ease of turning....but any soft, easily-turned hardwood will work equally well.

First, decide on your design. Ours is pretty traditional and you should have little difficulty duplicating it by following the drawing. You could try a straight tapered *pencil-post* design with a Shaker flair...or a more contemporary design. The choice is yours.

Start the building process by cutting your 4" x 4" stock to length, being sure to allow an extra 1/2" on each end. Separately turn and finish sand (while on the lathe), each of the three main spindle parts (A, B, and C).

Next, resaw some 4" x 4" scrap into 1-1/8" square pieces 12" long for the six coat pegs (E). These can be most efficiently turned end-to-end, two at a time, from a single length of stock.

TIP: For added efficiency and a dead-on match, use Shopsmith's Lathe Duplicator.

Now, lay out the legs (D) on your 2" x 4" stock.. Start by cutting the angle for the leg tops. Drill the 3/8" dowel peg holes using the MARK V's Horizontal Boring Mode. Be sure to set up some stops so all (8) holes are drilled in the exact same relative position.



Use your Bandsaw to cut out your four legs. At this point, you can either round-over all leg edges using your Belt Sander or an inflatable, Contour Sanding Drum ...or you can create more intricately shaped edges using a Router set-up, or a Shaper and the cutter profiles of your choice.

Next, set up your MARK V in Drill Press mode and bore the (8) 3/8" holes in the Bottom Spindle (C) for the Leg dowel pegs. Be sure to measure and mark the positions of these holes accurately, so they line up precisely with the mating holes in each Leg end.

The tapered Top Spindle (A) has six equally positioned holes that divide the spindle into three equal sections. Here's how to do this: Wrap a piece of paper around the turned Spindle (A) and mark the diameter of the Top. Flatten the paper out, measure the diameter and divide it into three equal sections. Transfer these marks onto your turned Spindle.

With your MARK V Worktable tilted to 30-degrees, use a shop-made V-Block jig to hold the Spindle while you drill the angled Coat Peg holes with a Forstner Bit. See Figure 1.

Prior to final assembly, drill 1-1/4" deep x 3/16" dia. pilot holes into the bottom of Spindle (A), both ends of Spindle (B) and the top of Spindle (C). These holes are for the Dowel Screws (G).

Apply a small amount of soap, beeswax, paste wax, or paraffin to both ends of the Dowel Screws and "test-assemble" the three-part Spindle. Take the Spindle apart and remove all traces of soap, beeswax, paste wax, or paraffin squeeze-out.

Apply ample glue to the end grains of all Spindles where they will join together...tighten them down...remove any glue squeeze-out and allow to dry overnight.

Finally, glue and dowel the Legs (D) and the Pegs (E) to the assembled Spindle and allow to dry for 24 hours before applying the finish of your choice.



LIST OF MATERIALS -
(finished dimensions in inches)

A	Top Spindle	2-1/2 dia. x 13-3/4
B	Middle Spindle	3-1/4 dia. x 33
C	Bottom Spindle	3-3/8 dia. x 14
D	Legs (3)	1-1/2 x 3-1/2 x 14
E	Pegs (3)	1 dia. x 6
	Pegs (3)	1/dia. x 5
F	Dowel Pegs (8)	3/8 dia. x 2
G	Dowel Screws (2)	5/16 dia. x 2-1/2

Hall Tree Layout

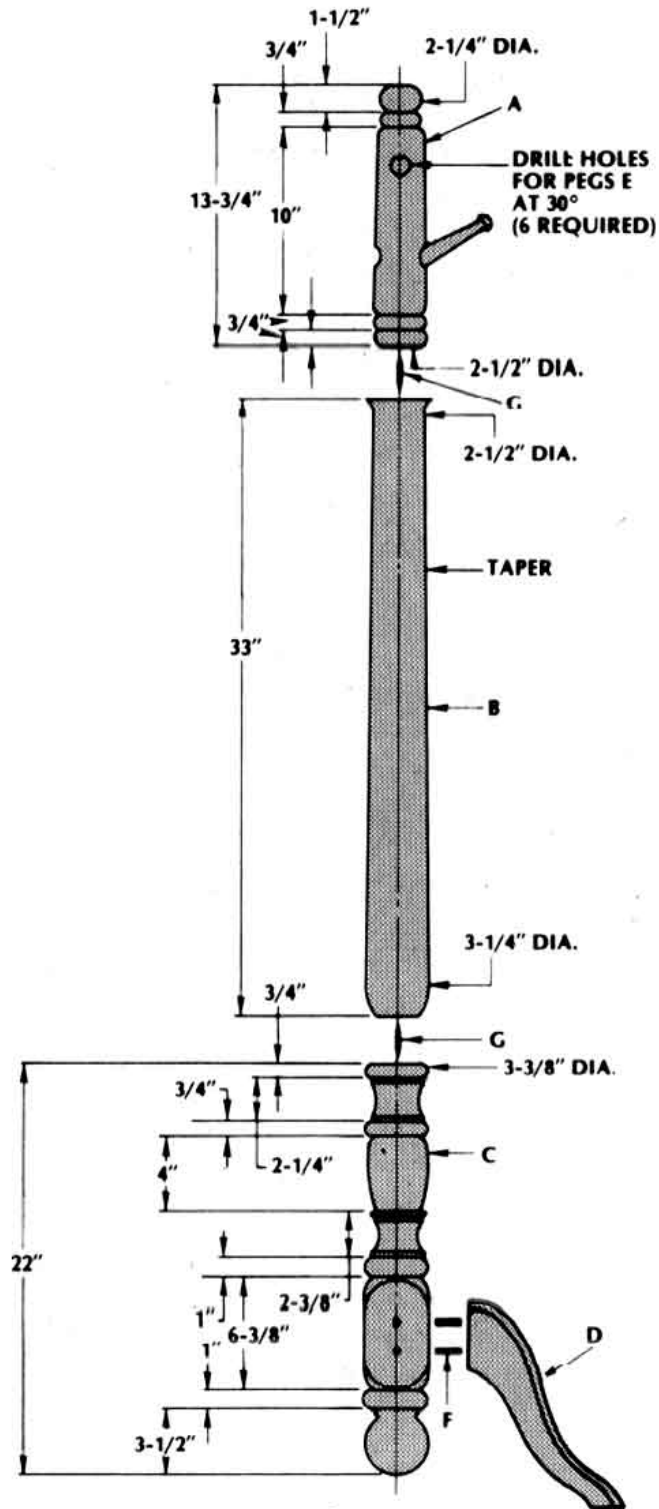

Peg Layout

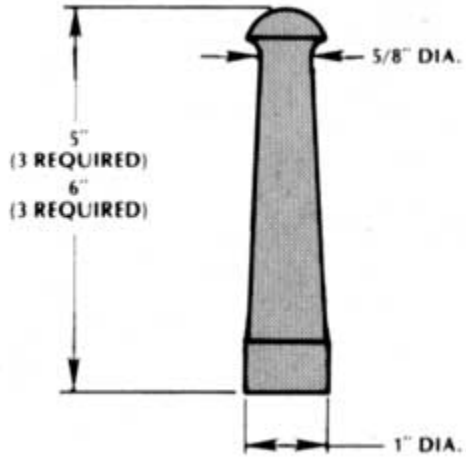

Foot Layout

ONE SQUARE = 1/2"

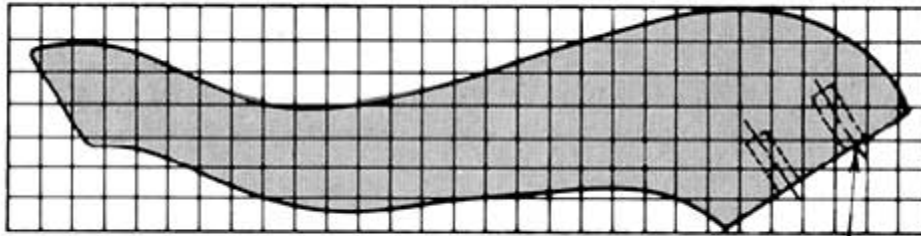

3/8" DIA. × 1" DEEP HOLES
(2 REQUIRED)

Hanging Glass Door Cabinets

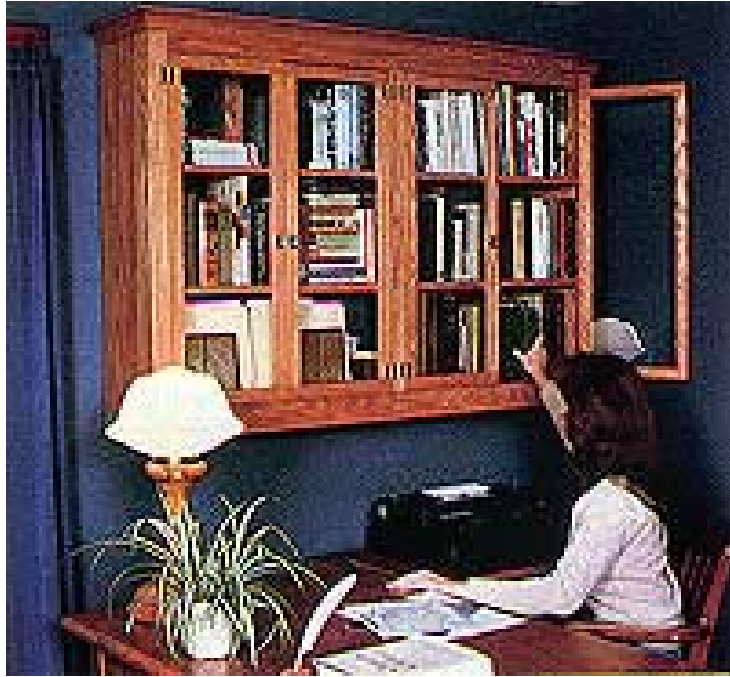

Most homeowners suffer from an unwritten law: "Stuff" (books, collections, dishes, etc.) expands to fill the space available... **and beyond**. Consequently, while you always seem to have an abundance of this kind of "stuff", you never seem to have enough places to stash it.

Our attractive hanging cabinet is a great way to add that necessary storage space. And, as you can see by our example, the cabinet joiner used to put it all together is really quite simple. The shelves are joined to the sides with simple dadoes and rabbets. The front frame is doweled together and then merely butted-up to the shelving assembly.

The rails and stiles of the doors are joined together with slot mortise-and-tenons. Although this joint isn't as strong as a true mortise-and-tenon, in a light door frame such as ours, it's perfectly acceptable.

Hanging cabinets are fastened to walls by bolting or screwing them directly to the wall studs. In our cabinet, two vertical stringers are attached to the backs of the shelves, spaced to line-up perfectly with our wall studs. These stringers are then fastened to the wall studs with lag screws. You could also use 1" x 2" "bridges": just cut two of these to the same length as the shelves and fasten them to the studs in the wall. Then fasten the top and bottom shelves to these "bridges".



You can easily vary this design to meet your specific storage needs. Make your shelves 11" to 15" deep for bookshelves, 6" to 11" deep for curios or collections and 15" to 21" deep for use as a kitchen cabinet.

Inset doors...while they may look "classy", can be far more difficult to make. Rabbeted (or "over-lapping") doors are infinitely easier. Add a solid wooden panel instead of glass if you don't want to see the cabinet contents.

LIST OF MATERIALS –

(finished dimensions in inches)

A	Shelves (4)	3/4 x 11 x 58
B	Sides (2)	3/4 x 11 x 40-1/2
C	End Frame Stiles (2)	3/4 x 2 x 40-1/2
D	Middle Frame Stile (1)	3/4 x 2 x 34-1/2
E	Frame rails (2)	3/4 x 3 x 54-3/4
F	Stringers (2)	3/4 x 2 x 38-1/4
G	Door Stiles (8)	3/4 x 1-1/2 x 34-3/8*
H	Door Rails (8)	3/4 x 1-1/2 x 13-1/8*
J	Crown Molding (optional)	3/4 x 2-5/8 x 90

Hardware

(50)	1-1/2" x #10 (flathead)
(4 panes)	1/8" glass, cut to suit
(4 pairs)	1" x 2" cabinet hinges
(4)	cabinet door pulls
(4)	cabinet door catches

** This will leave a small amount of clearance so the doors will open and close easily. You might get a better fit by cutting the doors 1/8" oversize, then shaving them down*

Molding Layout

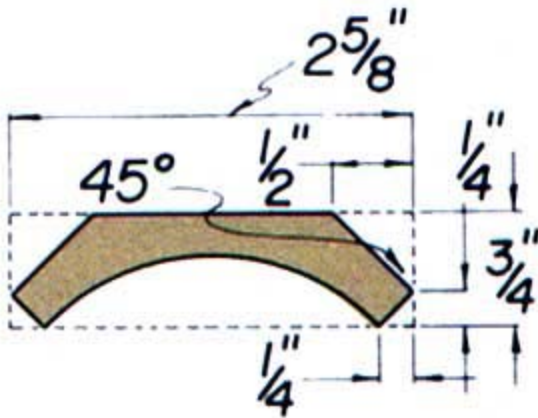

MOLDING LAYOUT

Door Frame Assembly

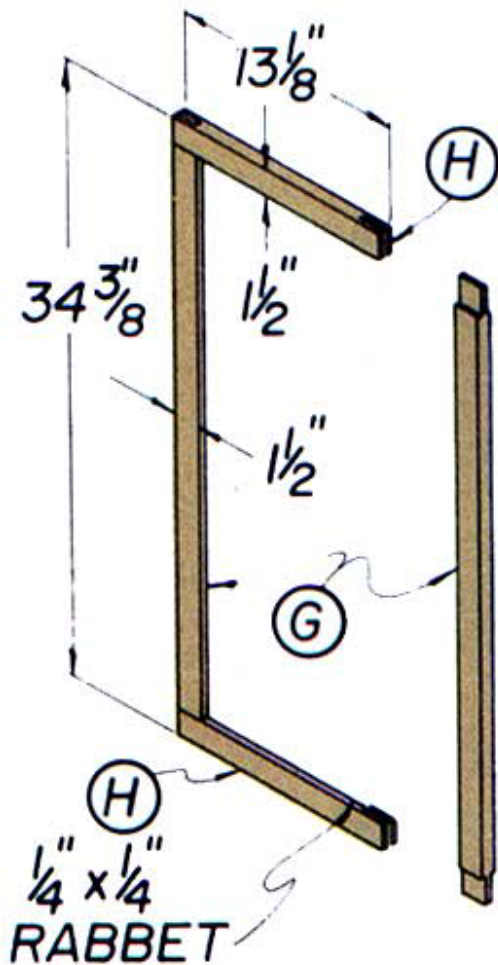

NOTE: ALL STOCK ³/₄" THICK

DOOR FRAME ASSEMBLY

Hanging Cabinet Assembly

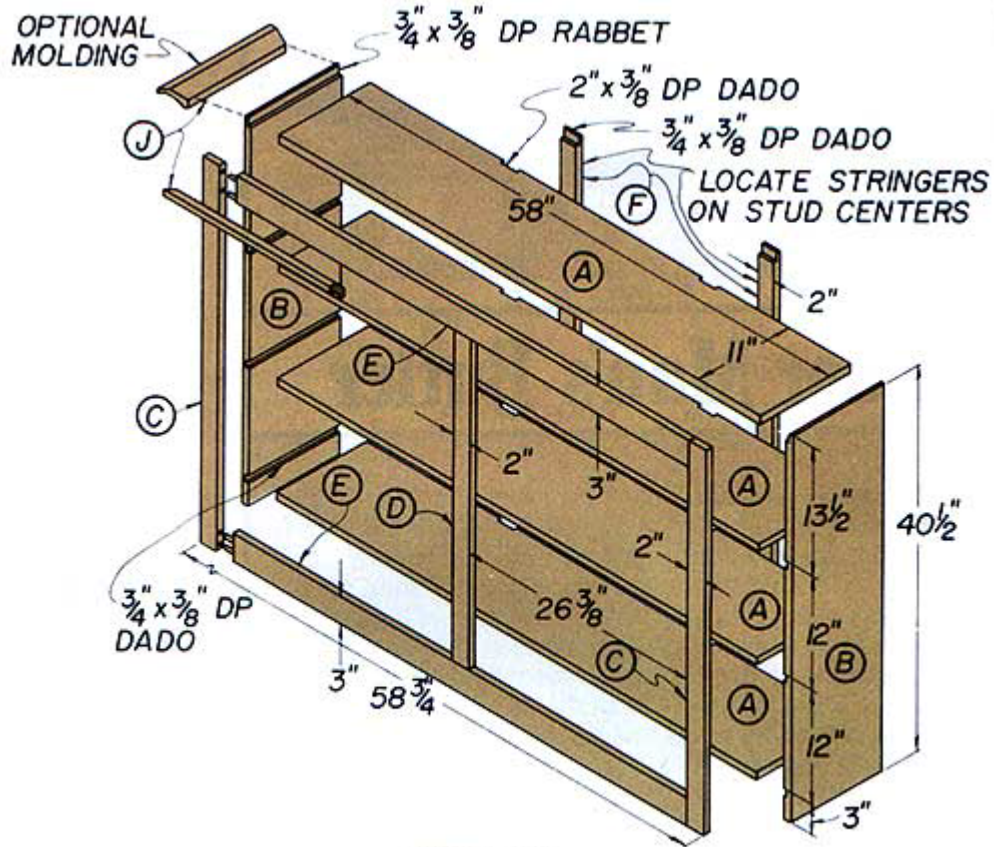

NOTE: ALL STOCK $\frac{3}{4}$ " THICK

HANGING CABINET ASSEMBLY

Adjustable Plant Shelf

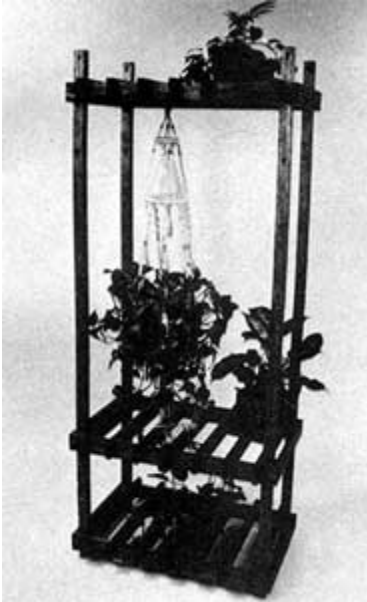

Here's an Adjustable Plant Shelf featuring a design that makes it universal enough to work with virtually any home decor -- and simple enough to build that you'll have plenty of opportunities for some nice profits when you sell them at craft shows, festivals and flea markets. Slip-in pegs allow instantaneous adjustment of the main plant shelf height.

We suggest that you offer different priced models made of different woods (water resistant woods like Western red cedar, cypress, teak or redwood are best)...and with either three, four or five shelves for each unit. You can even offer additional shelves (with pegs), individually as "accessories". Plus, if our dimensions don't suit your fancy, feel free to change them. With a project like this, it's really easy.

Each shelf is a simple frame with cross-lapped notches that accept notched, drop-in slats that will form the shelf bottoms while allowing light to pass through to the plants below. The frame corners have 1/2" diameter peg (E) holes that mate-up with matching hole patterns in the four vertical stiles (D). You'll find that the easiest tool to use when making these cross-laps is the Dado Blade. Set everything to make 3/4" wide dados, 1" deep. Use your Rip Fence with a piece of wood attached to its face to serve as a stop when cutting these laps equidistant from both ends of your shelf slats (C) and frame sides (A&B).

Assemble the frames with waterproof glue and woodscrews (brass or stainless steel screws are best), since they won't rust. Don't glue in the center slats on each shelf...only the two slats on each shelf end that attach to the vertical stiles.

Cut the four vertical stiles (D) from 1-1/2" x 1-1/2" stock that's at least 6" long Using your Drill Press, bore the 1/2" peg holes every 8" along their lengths. The top and bottom holes should be 4" in from either end.

Finally, turn the pegs you'll be needing for each shelf, then place and assemble each shelf to the vertical stiles.



Suggested retail price: \$25 and up, depending on number of shelves included and wood species used.

LIST OF MATERIALS -

(finished dimensions in inches)

A	Front frames (6)	3/4 x 2-1/2 x (length)
B	Side frames (6)	3/4 x 2-1/2 x 17
C	Slats (x)	3/4 x 2-2/2 x 17
D	Vertical stiles (4)	1-1/2 x 1-1/2 x 72
E	Peg blanks (12)	1-1/4 square x 2 long
F	Peg blocks (12)	3/4 x 2 x 1-1/2

Hardware

Brass or stainless wood screws (36)	1-1/2" x #10 (flathead)
Dowel buttons (36)	3/8" dia (for covering screw heads, if preferred)

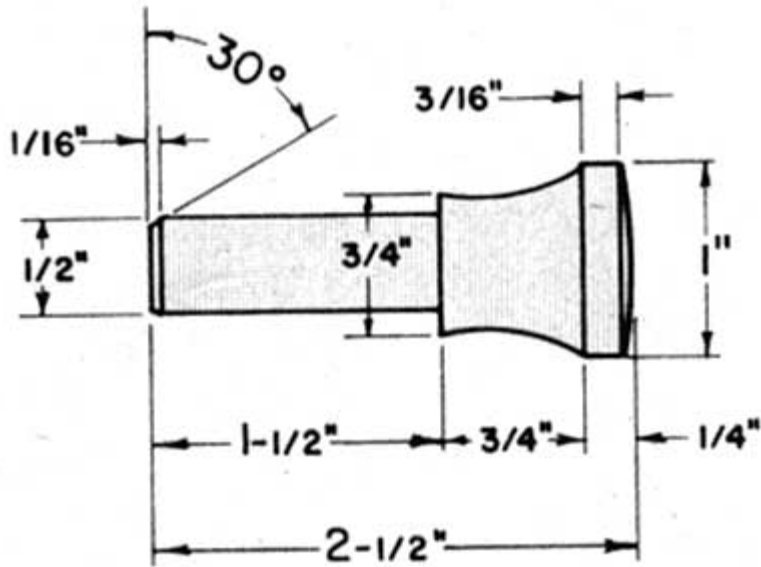

PEG

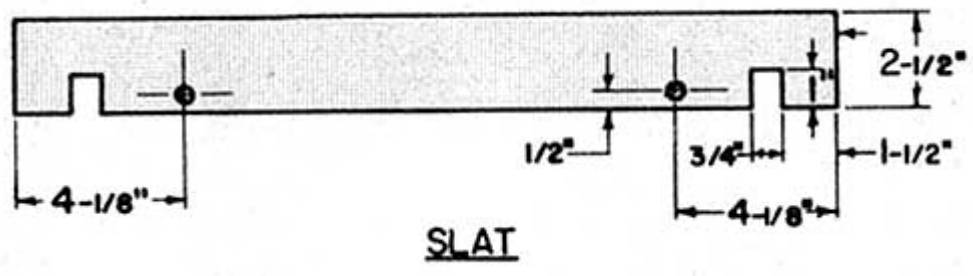

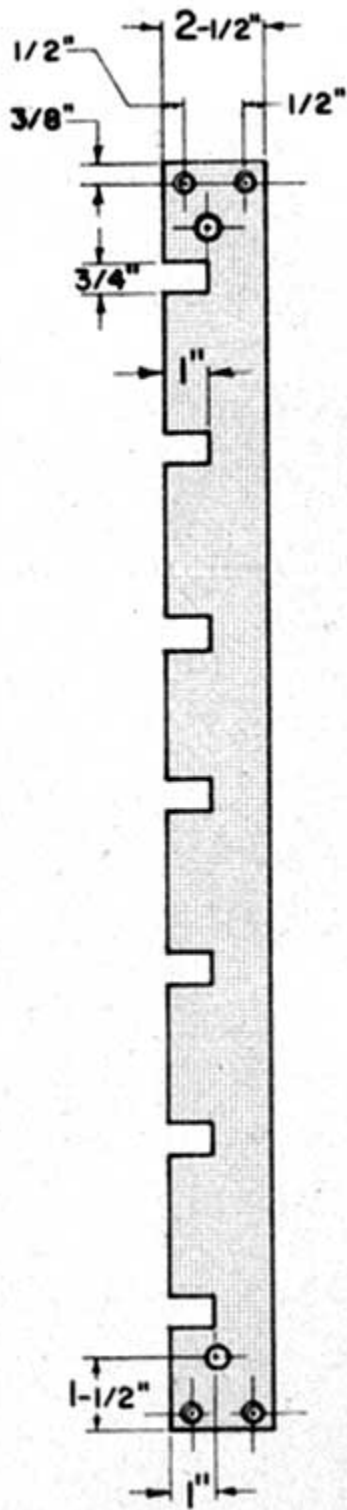

FRONT FRAME

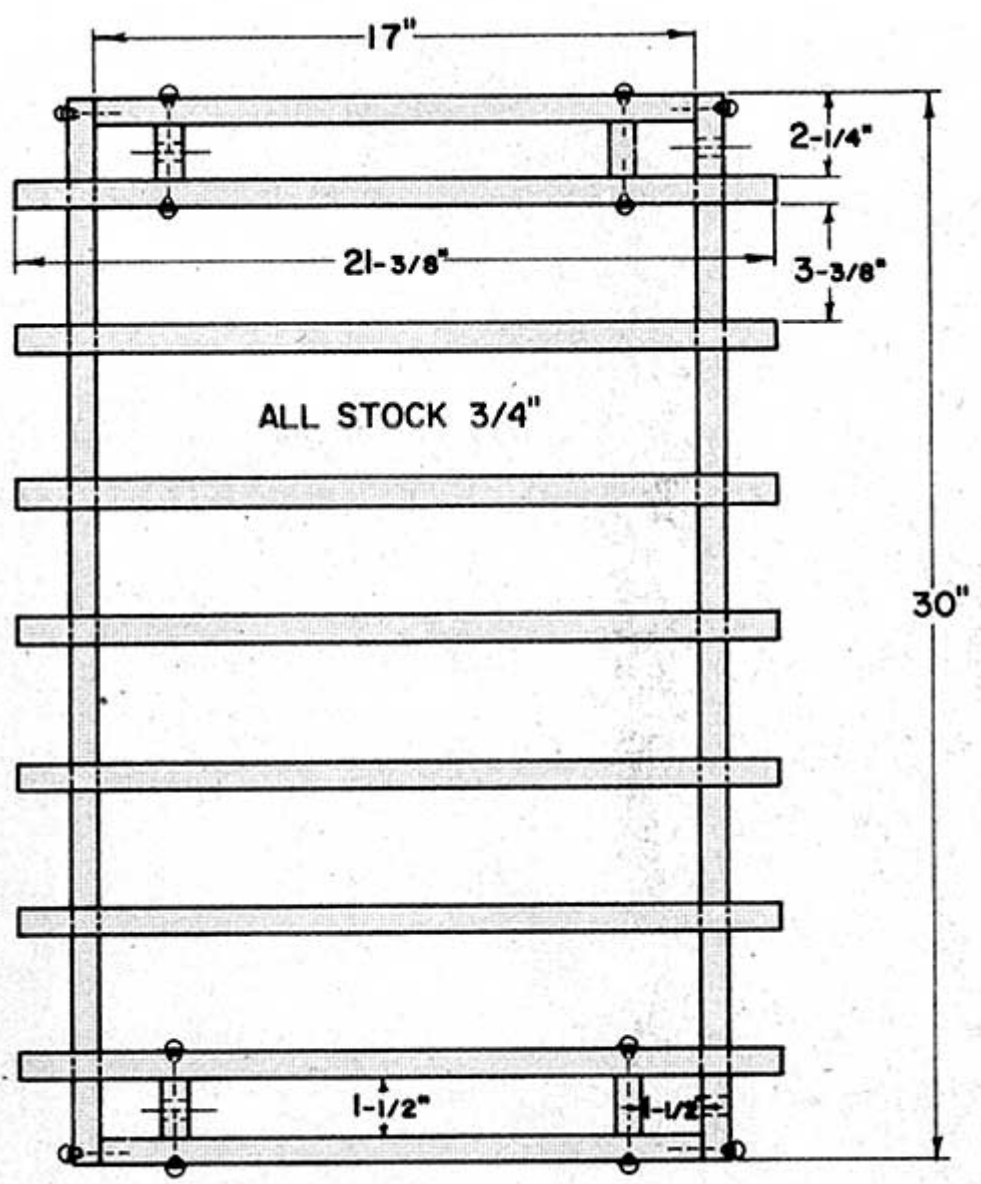

SHELF LAYOUT

ADJUSTABLE PLANT SHELVES

ASSEMBLY

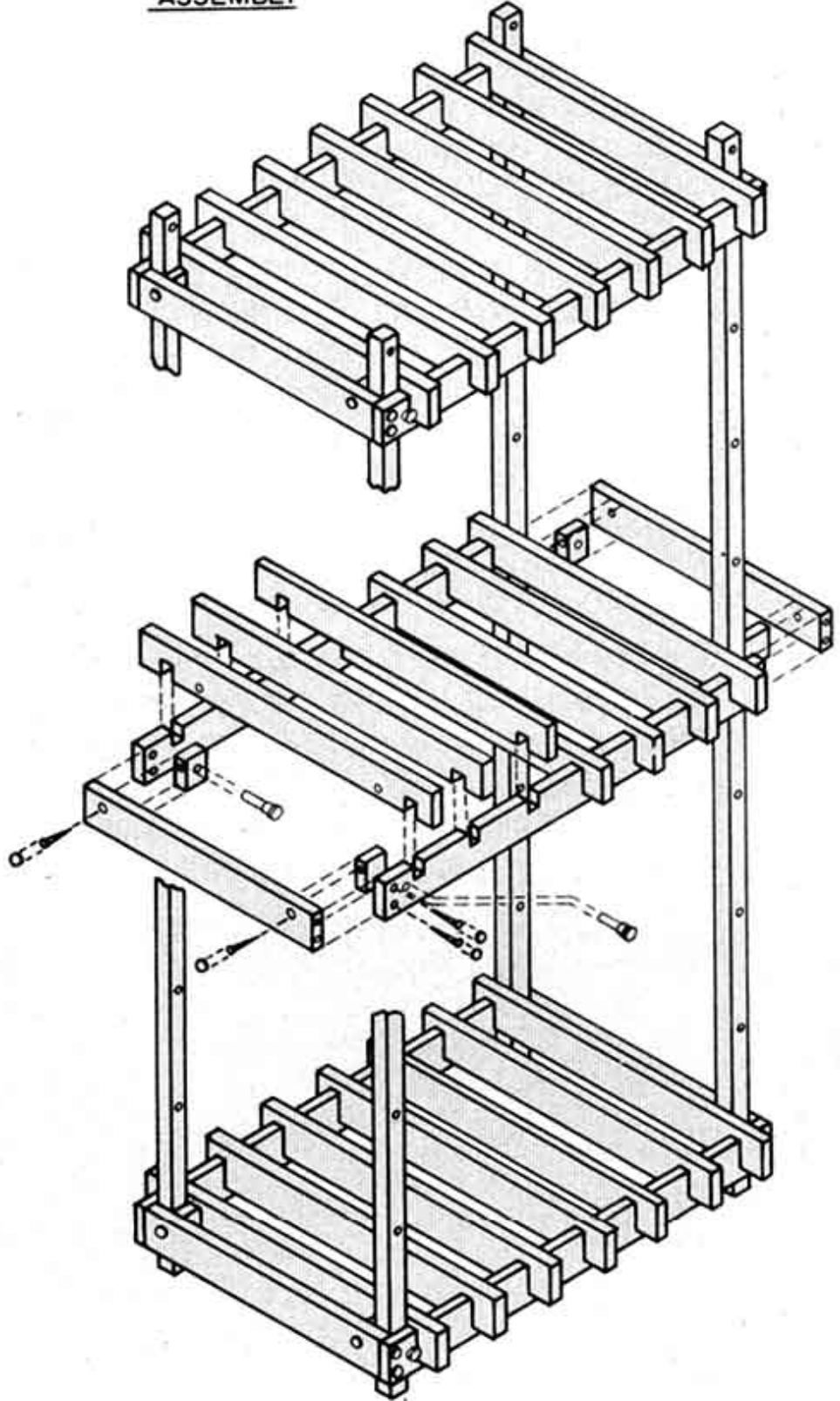

ANTIQUe QUILT DISPLAY RACK



If you're like most people, your family heirlooms are precious to you. Such was the case with the author's daughter when she wanted to display one of her great, great grandmother's antique quilts for all to see. The project began with a sketch of the idea. The final result was a red oak frame with simple lines and easy-to-construct plans.

In the case of this particular project, what makes it truly unique was the source of the wood used in its construction. Several years ago, the author's family church replaced their old, red oak pews. He decided to buy several of them...not really knowing what he was going to do with them at the time. Then came the quilt rack request from his daughter, and a "mission" was launched. All of the pieces of this project (except for the dowel stretchers) were cut from the pews, giving them a new life that will be passed on from generation-to-generation.

The wood you use for yours, of course, probably won't come from old church pews, but that won't make much difference. It's a project we're sure you'll enjoy building, so let's get started.

Getting Started

Since you won't need a lot of wood for this project, it should be fairly inexpensive to build. And, if you get started and discover that some of the thicknesses you need are either not readily available or just too expensive,



you can always glue-up thicker pieces from thinner ones. **IMPORTANT:** When working with glued-up stock, it's always a good idea to allow the glued-up pieces to dry thoroughly for 24 hours or so before machining them. Un-cured glue-ups could separate during machining, causing injury.

Making the Bases

Let's get started with the Bases (A). Begin by cutting the two Base blanks to size, according to the Bill of Materials. As mentioned earlier, if 2-1/4" stock is not readily available, just glue-up three pieces of 3/4" to 1" thick stock to make your 2-1/4" blanks. These glued-up pieces will actually be stronger than a single piece of 2-1/4" stock, plus you'll get an attractive end grain pattern that you wouldn't get with a single piece of stock. Once your pieces are glued-up, be sure to wipe off any excess glue with a damp cloth before it dries.

After the glue has dried for 24 hours, cut your bases to 3" x 17", then use your Jointer or Thickness Planer to thin them down to 2-1/4", if necessary. As shown in the diagram, the Bases have a 3" long chamfer that slopes down 1/2" at the ends of each side. There's also a peak in the bottom, starting 1-1/2" in from each end that rises and meets in the center, 3/4" up from the bottom. Mark these lines on your Base pieces and cut them using your Bandsaw or Scroll Saw. Sand all areas smooth, then use a 3/4" Brad Point Bit to bore two 1/2" deep holes for the leg tenons, as shown in the diagram.

Making the Top Caps

The Top Caps (C) need to be cut with extreme care. Start with two pieces of stock 1-1/2" x 6" x 12". If you're unable to make them from solid stock, glue-up some stock from thinner pieces, just as you did for the Bases. Once the glue has set-up for 24 hours or more, there are two ways you can go about marking and cutting these pieces:

The first is to either make a template from the diagram or use a pencil compass or set of dividers to mark two half-circles with 4" and 6" radii... then simply cut them out, using your Bandsaw.

The second is to use your Bandsaw with the Bandsaw Circle Cutter to cut the curves. **NOTE:** If you decide to use this approach, you'll have to start with blanks that are 6-1/2" to 7" wide instead of 6" wide, so your Circle Cutter has a place for its center to "seat" on your workpiece.

When cutting the Caps, don't forget to stay **OUTSIDE** your lines by 1/32" to 1/16" to allow for sanding down to the finished dimension. Use your Disc



Sander for the convex (outside) edges and your conventional Drum Sander or Contour Sanding Drum for the concave (inside) edges.

As an added touch, you should rout decorative edges on the curves of the Top Caps. In our example, we used a hand-held router and a 3/8" rabbeting bit to create this detail. However, you could also use your router and a Roman Ogee, Chamfer or Beading Bit to accomplish the same task. It's your choice.

Turning the Legs

Since some of the areas of the Legs (B) are to remain square, your stock needs to be cut, planed and sanded smoothly to size before turning. Start by sizing your turning stock to 1-1/2" x 1-1/2" x 30", as per the Bill of Materials. Follow our design for the legs as shown in drawing "B", or create your own design. Just remember that the areas marked "leave square" must not be turned to allow for the attachment of the stretchers, as shown in the diagram. As with the Top Caps, there are two ways you can go about turning these Legs:

The first is to turn each Leg freehand, following our diagram and using a set of Outside Calipers to periodically check your diameters at various points along the length of each Leg.

The second is to create a hardwood template for your design...or to turn your first leg and use it for your design to duplicate your other three legs using a Lathe Duplicator. Using this second approach will help ensure that all four Legs match perfectly.

IMPORTANT TURNING TIP: Extra care must be taken when forming the tenons on the ends of your legs. These tenons must be exactly 3/4" in diameter to fit into the mating holes on the Top Caps (C) and Bases (A). If you mess up and remove too much stock (resulting in a tenon that's less than 3/4" in diameter), you can often correct this by hand-planing a 1/2" wide shaving of straight-grained hardwood about 3" long. Then, glue and wrap the shaving around your tenon and allow it to dry for about 24 hours. At this point, you can either re-turn your tenon or simply sand down the shavings carefully until the tenon fits snugly into your hole.

Assembling and Finishing

The only remaining pieces to be made are the Stretchers (D). In our case, they're simply 1" diameter oak dowel rods, cut off to a 30" length.



The final step is assembly. Begin by dry-fitting all the parts together just to be sure everything fits properly (see the exploded view drawing). If everything fits as it should, disassemble, then glue and clamp the components together, being sure to check each step for squareness as you go. Be sure to use a damp cloth to wipe away any excess glue as you go so your stain coats evenly.

Depending on the type of wood you decide to use, you may want to use a sanding sealer before you apply your final finish. This will seal and make all surfaces uniform, helping you achieve the even-looking stain coverage you want. When the sealer has dried thoroughly, lightly sand everything with 400-grit or finer sandpaper. Use a tack cloth to remove and dust, then apply your choice of finish. We used a clear oil finish to bring out the rich red color of our oak Rack.

LIST OF MATERIALS -
(finished dimensions in inches)

A	Bases (2)	2-1/4 x 3 x 17
B	Legs (4)	1-1/2 x 1-1/2 x 30
C	Top Caps (2)	1-1/2 x 6 x 12
D	Stretchers (5)	1 dia. x 30 long dowel rods

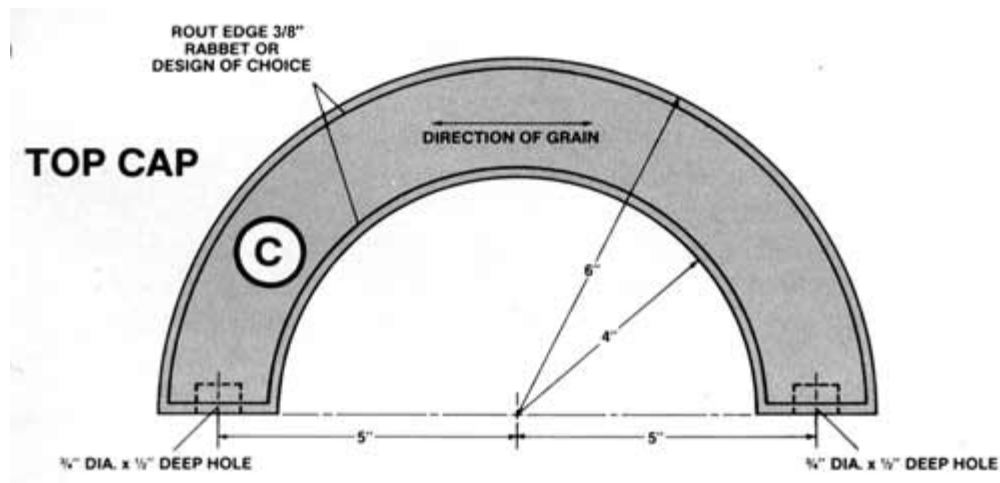

1/2" CHAMFER

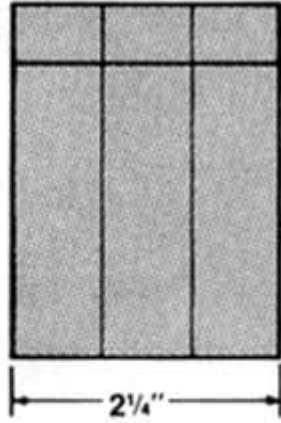

BASE
(end view)

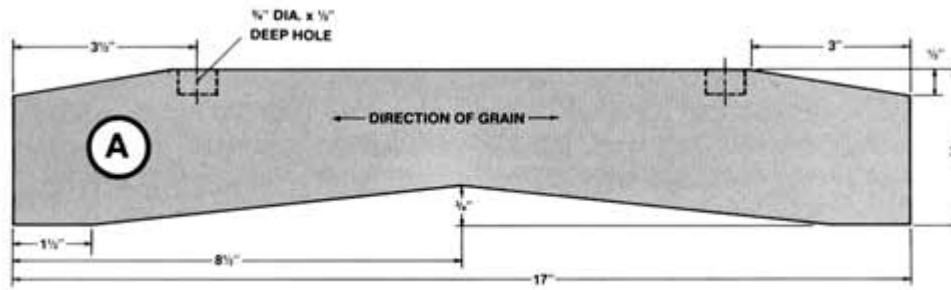

BASE (side view)

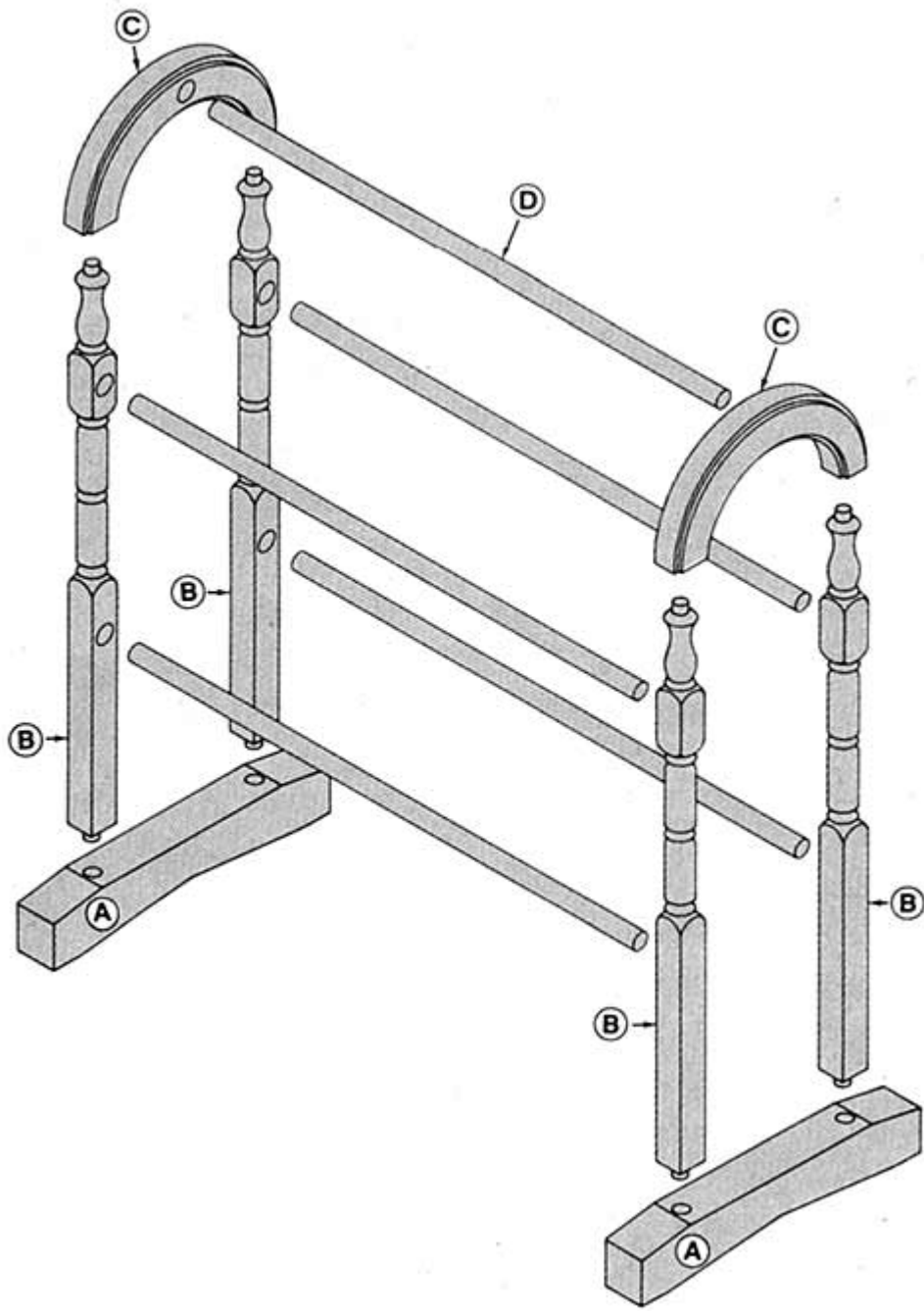

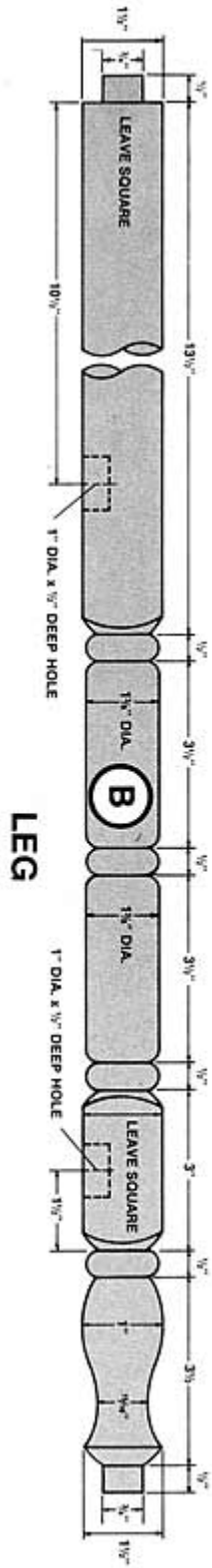

HEART SHAPED 3-TIER STAND



Here's the perfect addition for almost any room in your home. This attractive, 3-tier Stand with its heart-shaped shelves is ideal for a multitude of uses. A nightstand in the bedroom...telephone stand in the kitchen...plant or display stand in the family or living room. The list goes on.

We're sure that once you build one for yourself and discover how easy and quick it is to make, you'll want to build them for all your special friends and relatives. We cut out our shelves on the Bandsaw. However, depending on



how many Stands you want to build, the Shopsmith Overarm Pin Router could make fast, easy work of cutting out and shaping the edges of the shelves.

Our example is made of cherry.

- 1: Joint and glue-up sufficient stock to make the three Shelves (A). Use Bar Clamps to ensure a tight fit and be sure to allow at least 24 hours for the glue to dry properly before proceeding.
- 2: Once the glue has dried thoroughly, examine the stock carefully and use a Hand Scraper to remove any glue squeeze-out. Then run the stock through the Thickness Planer to bring everything to a 3/4" thickness.
- 3: Lay out one of the heart shapes on one end of your shelf stock...then rough-cut the three Shelf blanks off your 40" long piece of stock (See Fig. 1)

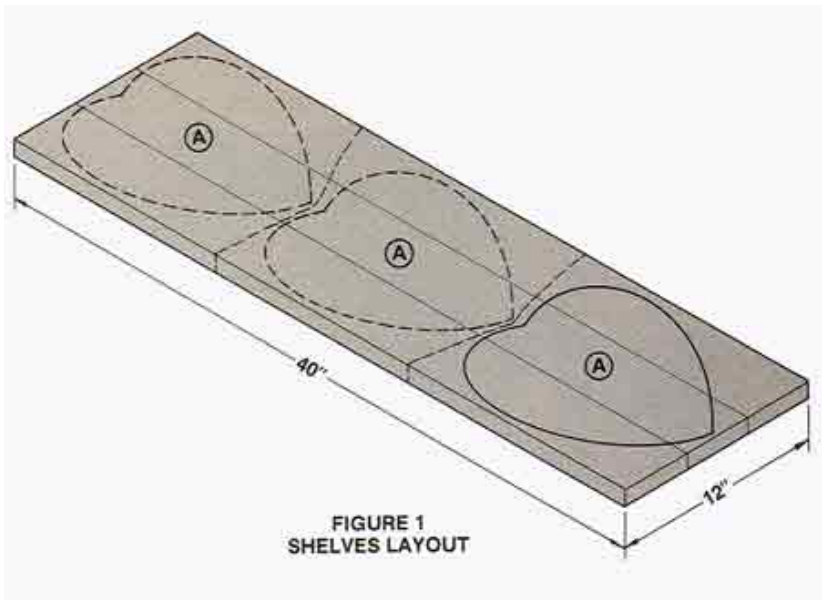

- 4: Stack the three Shelf blanks on top of one another with a couple of lengths of double stick tape between each Shelf in the stack (be sure the blank with the pattern on it is on top.)
- 5: Use your Bandsaw with the pad sawing technique to cut out all three heart-shaped Shelves at once.
- 6: While the Shelves are still taped together, set-up your MARK V to in the Disc Sander mode and sand the 1-5/8" wide flat surfaces at the three indicated points (See Fig. 2).

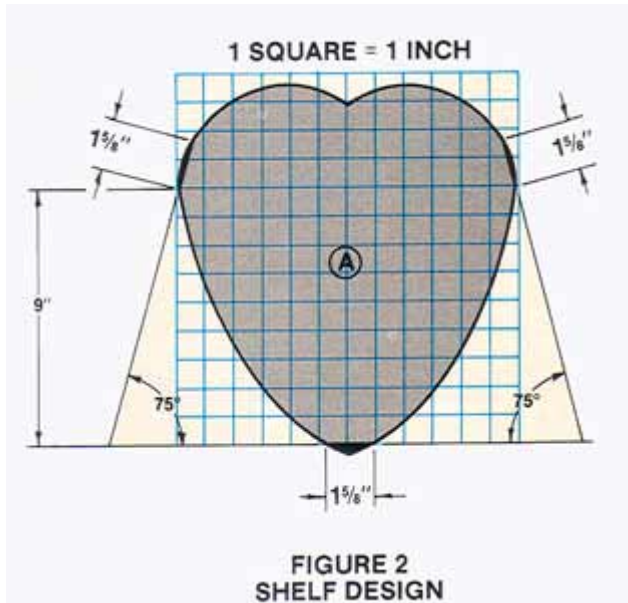

7: Cut the Legs (B) to size.

8: Following the dimensions in Figure 3, cut the 3/4" wide x 1/4" deep dadoes in the Legs (B)

9: Using a Shaper or Router set-up, round over the edges of the Shelves (A) and Legs (B) being careful not to round over in the areas where the Shelves and Legs attach to each other.

10: Counterbore 3/8" diameter x 1/4" deep holes in the outside of the Legs (B), centered over the dadoes (See Fig. 3), then drill through their centers for the screw bodies.

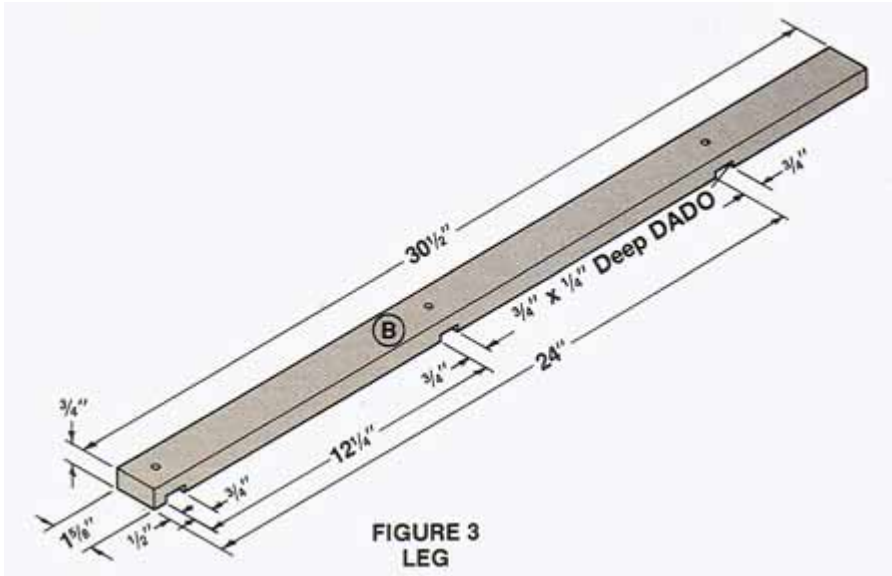

11: Assemble the Stand as shown in Fig. 4 using 1-1/2" x #6 wood screws. Cover the screw heads with 3/8" screw plugs or buttons.

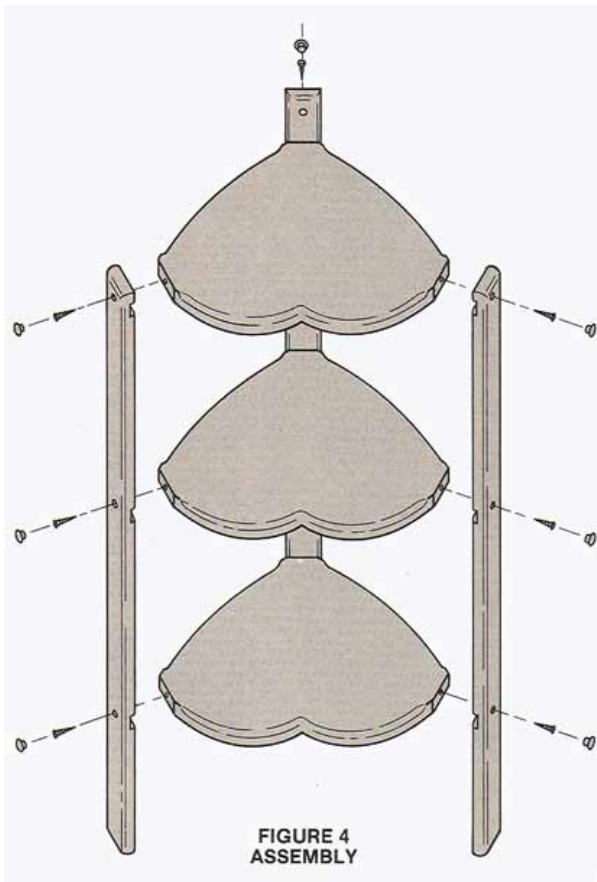



12: Finish to suit your décor.

Bill of Materials

(finished dimensions in inches)

A Shelves (3) $\frac{3}{4}$ x 12 x 12

B Legs (3) $\frac{3}{4}$ x $1\frac{5}{8}$ x $30\frac{1}{2}$

(9) $1\frac{1}{2}$ " x #6 flathead wood screws

(9) $\frac{3}{8}$ " dia. screw hole plugs or buttons

The Duck Napkin Holder



Fire-up your Scroll Saw (and Bandsaw) and get started on these quick, easy-to-make Duck napkin-holders. All you'll need is some wood, a roll of Double-stick tape, a few bucks worth of paint and a little time.

Begin by deciding what type of stock you're going to use. We selected poplar for ours because of its straight grain, easy working ability and the fact that we had planned to apply a filler and paint the finished ducks, anyway. Another option would be to make them out of attractive hardwoods such as cherry, walnut or oak and stain them or finish them with a natural oil instead of painting. It's your choice.

Start by transferring the pattern from the drawing onto a piece of 7/16" thick stock. Or even better, print the pattern out and make photo copies to the size you need. Decide how many ducks you want, and make one photocopy for every four ducks (if you're planning to pad saw them out, four at a time). Fasten your four-blank stacks together using Double-stick Tape, then merely glue a fresh pattern on the top blank in each stack (using artist's spray-on glue) and go to work. Much faster and easier.

Note: This is really a simple enough project idea that you could just as easily choose the profile of a completely different animal or virtually any object from the myriads of scroll saw patterns available today. If you can't find a pattern you like, just make your own by tracing outlines from magazines, then photocopying them to the sizes you want.

Next, drill a through hole for your scroll saw blade in the center cutout area of each stack and start sawing. If you also have a Bandsaw, you could probably work more efficiently by bandsawing the outside shape and scroll sawing the inside cutouts.



Finally, use your choice of Drum Sander, Disc Sander and Strip Sander to smooth the surfaces and edges. Apply a good coat of sanding sealer, then paint and top-coat to your liking. Pretty simple.

Suggested retail price: \$5 each -- \$15 for a set of four -- \$25 for a set of eight

1 Piece of stock per duck

7/16" x 5" x 3"

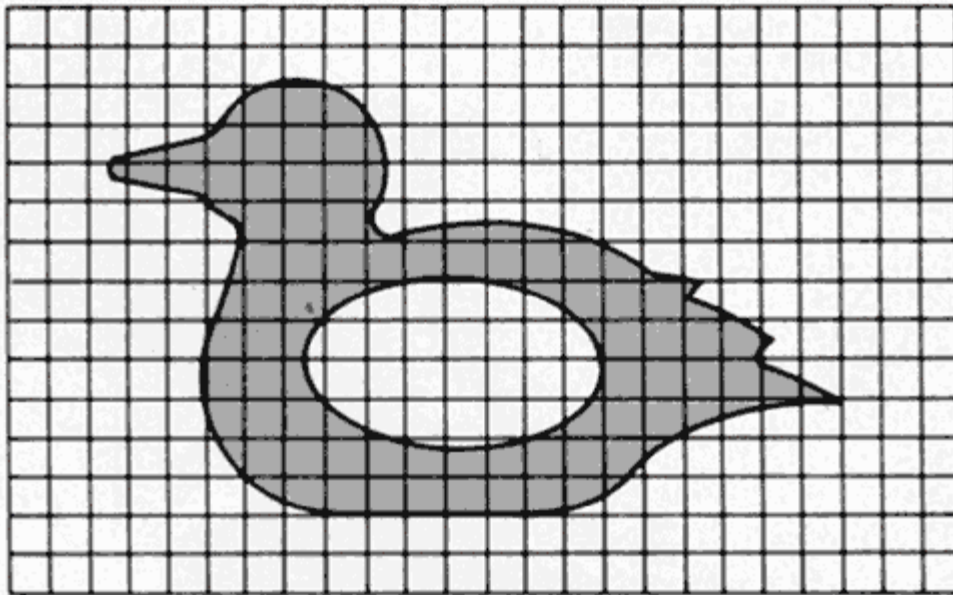

LIVING ROOM SOFA TABLE



Imagine how beautiful a professional-quality table like this will look in your living room, dining room or hall. You could position it against that empty wall that you've never quite figured out what to do with. Or, how about behind your sofa displaying flowers or your favorite family photos. Or, even in the dining room, showing-off the family's heirloom china serving pieces. The list goes on.

Whatever use you find for it, you'll quickly discover that these plans will guide you, step-by-step through the various processes you need to follow to create a fine piece of furniture that you'll be proud to display in any room of your home for years (and generations) to come. And you'll be even more proud when you can say to your friends and family..."Thanks for the compliment - I built it myself". So.....let's get started.

SIZING & SHAPING

- 1:** Glue-up the stock you'll need to create the Table Top (A) and allow it to dry thoroughly for 24 hours.
- 2:** Cut parts B,C,D,E,F,& G to size according to the List of Materials.
- 3:** Cut two pieces of stock to 2" x 2" x 25-1/2". Tilt your MARK V's Saw Table to 45- degrees and rip each of these two pieces lengthwise to make four right-triangle-shaped Legs (H). **See Fig. 1.** Using a 3/8" Round-Over Router Bit to lightly round off all three edges of the triangular shape, the full length of all four Legs (H).



4: Using your Lathe, turn two spindles 2" in diameter by 25-1/2" long. Locate the centers of each turned spindle and cut them in half lengthwise to create the four Leg Caps (I). The easiest way to accomplish this is by tilting your Bandsaw Table to 45-degrees and using your Rip Fence to form a V-Block jig to help you guide your turned spindles through the cuts. **See Fig. 2.**

5: Assemble the Frame Rails (B) and Frame Stiles (C) using 3/8" dowel pins and glue. See **Fig. 3.**

6: Cut the 1-3/4" x 3/8" x 3/8" mortises and tenons in the Bottom Ends (D), as shown in **Fig. 4.**

Mortising & Tenoning Tips: Mortising can be accomplished by boring a series of 3/8" diameter holes to remove the majority of the stock, then squaring everything up using a bevel edged wood chisel.

Tenoning can be accomplished by laying your workpieces flat on your Table Saw Table and cutting the tenons with a Dado Blade. As an option, you could also elect to stand your workpieces on end and cut the tenons with the aid of a tenoning jig. It will hold your stock perpendicular to your worktable as you make your cuts with a regular saw blade.

7: Cut the 4-1/2" x 3/8" x 3/8" tenons in the Top Ends (E), as shown in **Fig. 5.**

8: Cut the 1-3/4" x 3/8" x 3/8" mortises and tenons in the Bottom Rail (F), as shown in **Fig. 6.**

9: Cut the 4-1/2" x 3/8" x 3/8" tenons in the Facings (G), as shown in **Fig. 7.**

10: Cut the 4-1/2" x 3/8" x 3/8" - and 1-3/4" x 3/8" x 3/8" mortises in the Legs (H). Follow the diagrams in **Fig. 1.** carefully for placement of these mortises, especially at the bottoms (See **Fig. 1.**).

11: Use your Band saw, Scroll Saw or a hand-held sabre saw to cut out the curves in the bottom of the long Facings, as shown in **Fig 7.**

IDEA: The look of this table can be changed completely by merely changing the shape and design of the two facings (G). For example...make the facings completely straight - or add some fretwork cut-outs - the options are endless.



12: After your glue has dried for 24 hours, use your router to form the decorative Ogee design around the perimeter of the assembled Top Frame. Use a Ogee Router Bit to make these cuts.

13: Once again, using your router with a special beading bit, cut the bead and bevel designs on the Bottom Ends (D), Top Ends (E), Facings (G) and both surfaces of the Bottom Rail (F). Refer to **Figures 4A, 5A, 6A and 7A.**

14: Using your router, cut the round-over edge around the perimeter of the Top (A) - OR - cut another shape, as you desire.

15: Sand all parts smooth for assembly

ASSEMBLY

Following the exploded diagram (**Fig. 8**), begin the assembly of your Table in the following described sequence:

1: Glue and clamp Top (A) to Frame (B_& C).

2: Glue and clamp Legs (H) to Leg Caps (I).

3: Glue and clamp Leg Assemblies (H, I) to Bottom Ends (D) and Top Ends (E).

4: Glue and clamp Facings (G) to Leg Assemblies (H,I) - and Bottom Rail (F) to Bottom Ends (D).

5: Glue and clamp Table Top Assembly (A,B,C) to Leg and Frame Assembly (D,E,F,G,H,I).

6: Finish sand and stain completed Table with the color of your choice.

LIST OF MATERIALS - (finished dimensions in inches)

A	Top (1)	3/4 x 16 x 56
B	Frame Rails (2)	3/4 x 3-1/2 x 55-1/2
C	Frame Stiles (2)	3/4 x 3-1/2 x 8-1/2
D	Bottom Ends (2)	3/4 x 2-1/2 x 11-1/4
E	Top Ends (2)	3/4 x 5-1/4 x 11-1/4
F	Bottom Rail (1)	3/4 x 2-1/2 x 52-1/2
G	Facings (2)	3/4 x 5-1/4 x 51-1/4



H	Legs (4)	2 x 2 x (2-7/8 diagonal cut) x 25-1/2
I	Leg Caps (4)	2 diameter (half round) x 25-1/2
3/8 Dowel Pins (8)		

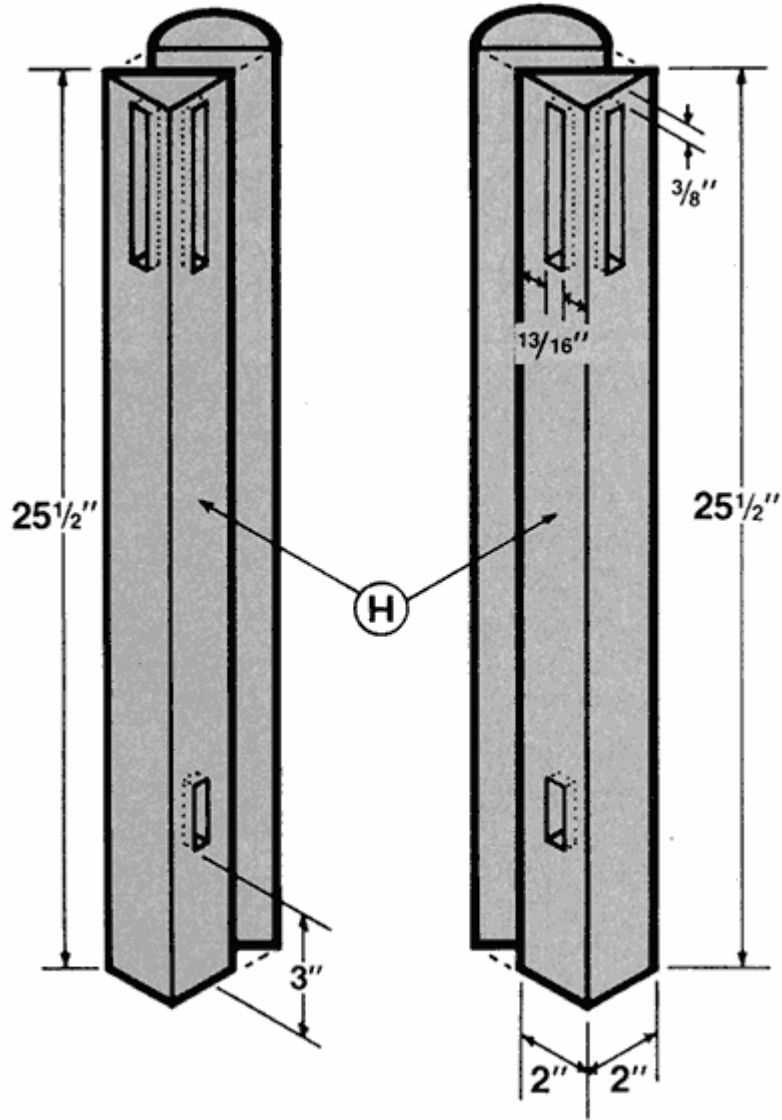

Figure 1
Legs

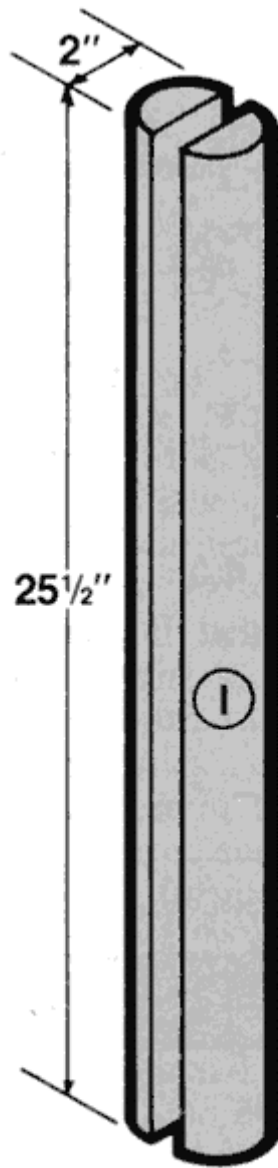

Figure 2
Leg Caps

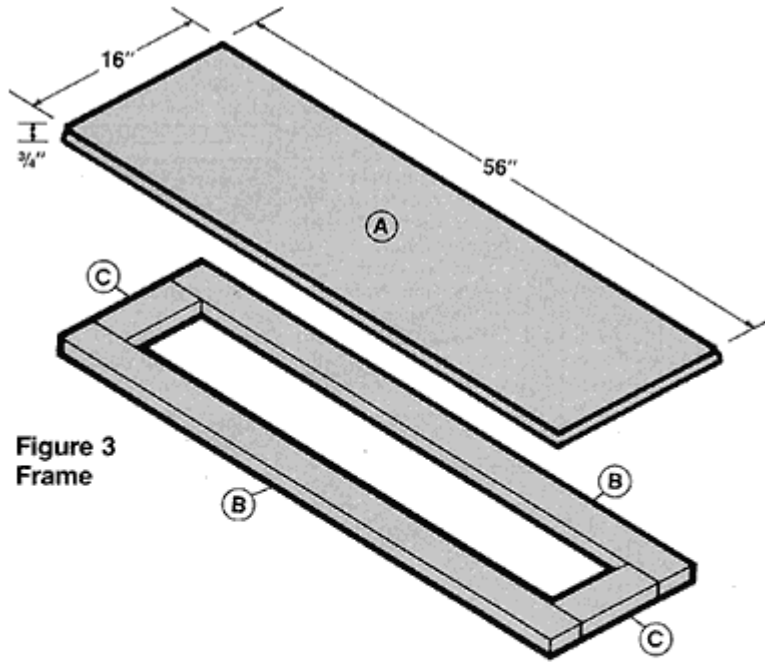
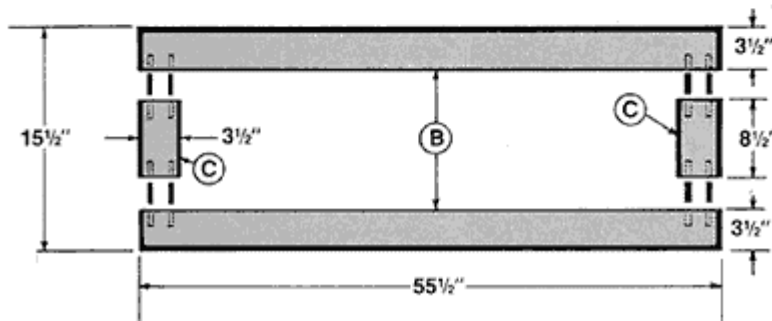

Figure 3
Frame



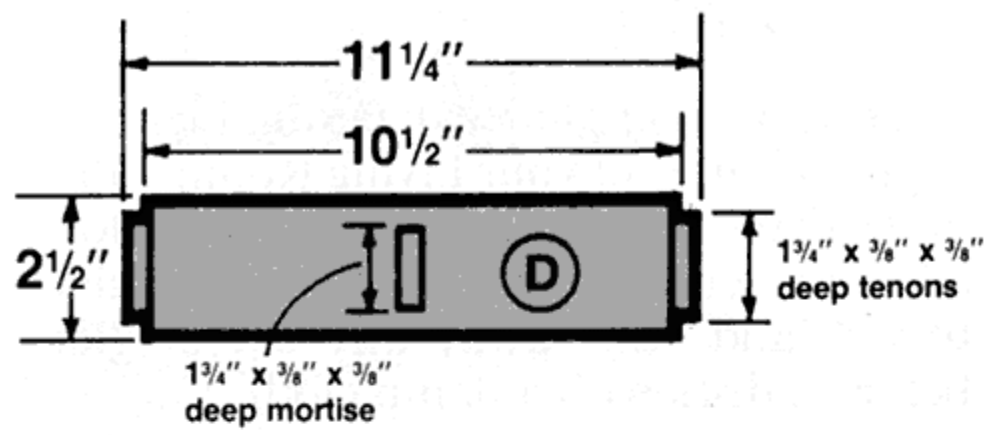

Figure 4
Bottom Ends

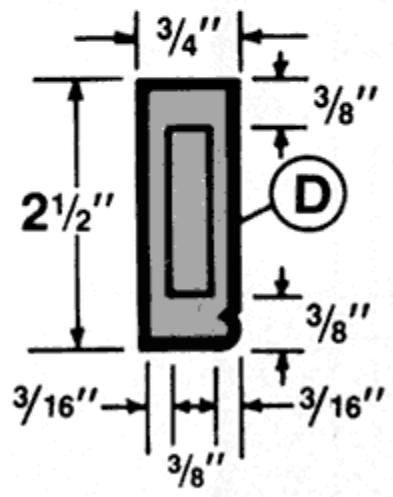

Figure 4A
End view

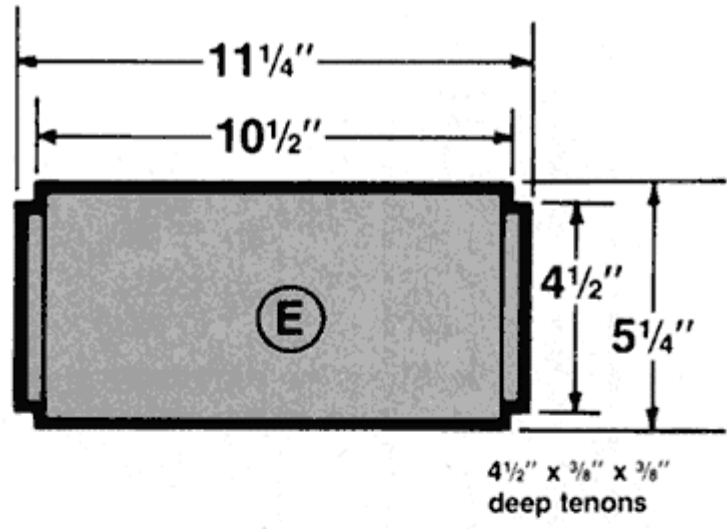

Figure 5
Top Ends

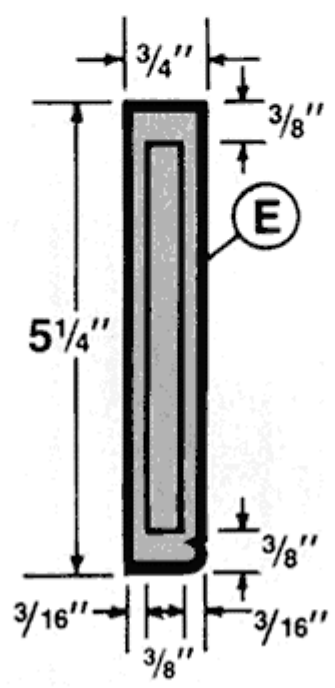

Figure 5A
End view

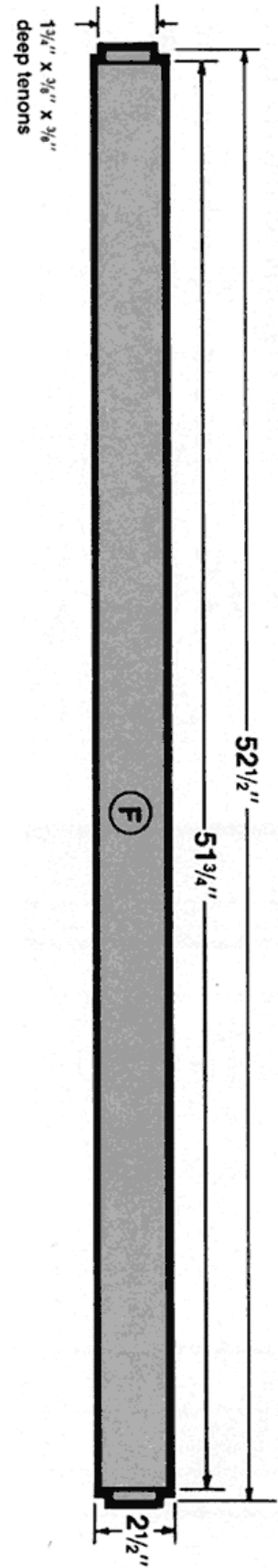

Figure 6
Bottom Rail

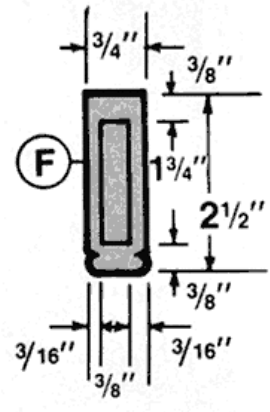

Figure 6A
End view

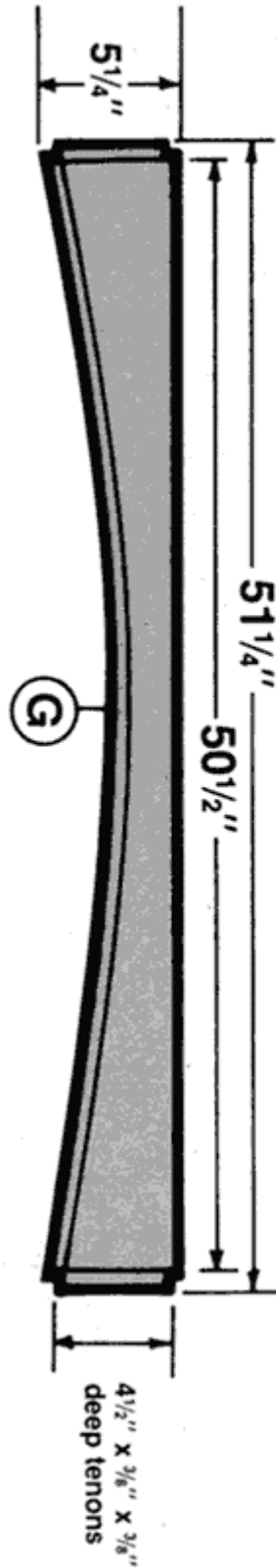

Figure 7
Facings

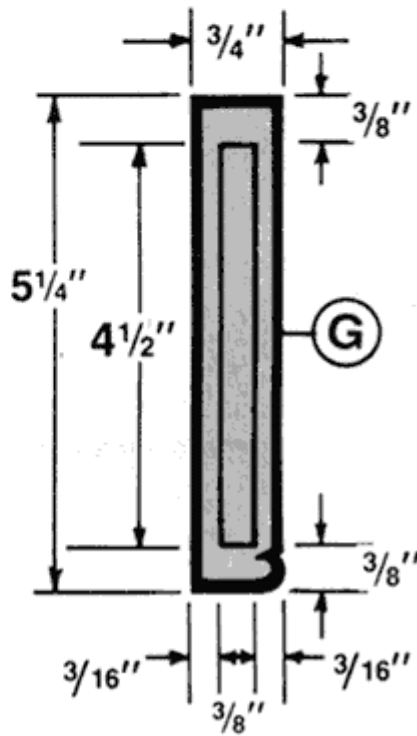

Figure 7A

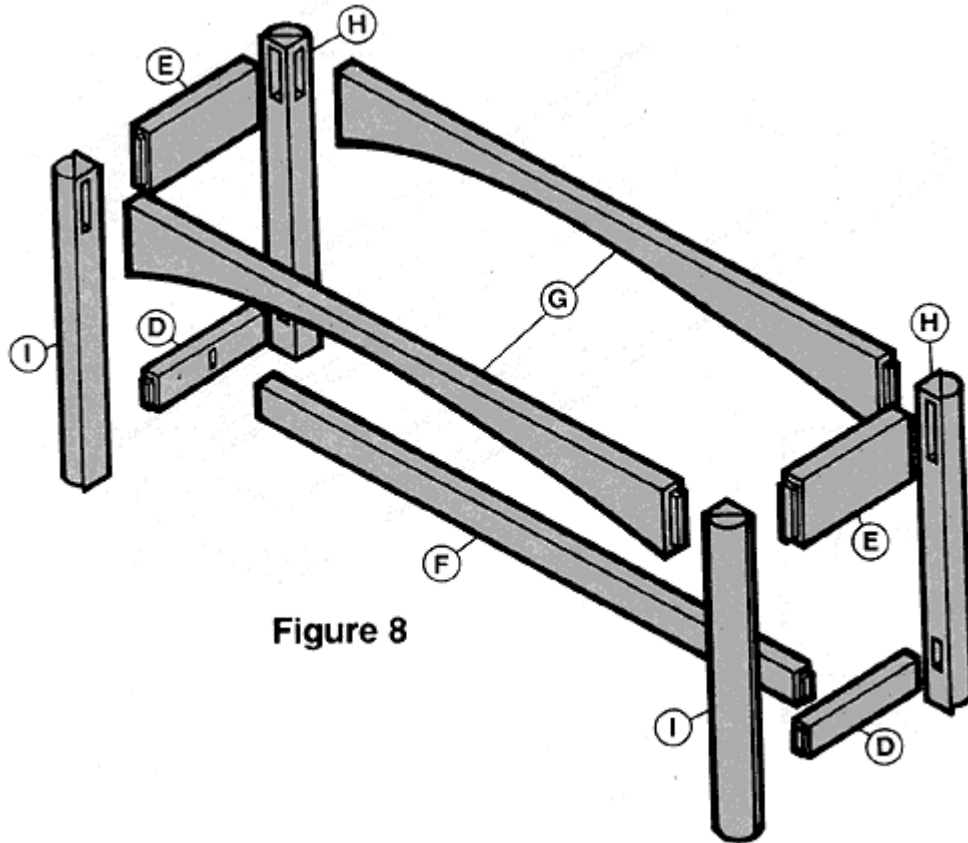
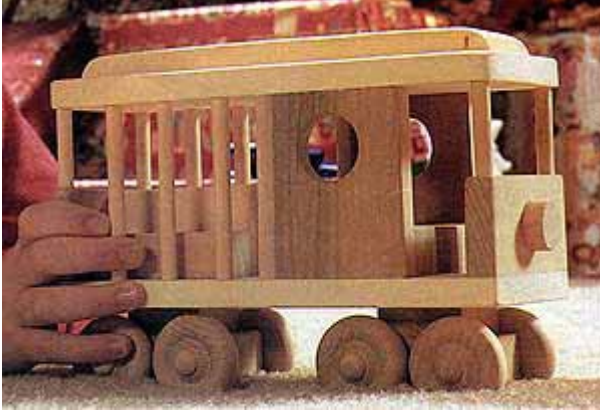

Figure 8



THE NOB HILL CABLE CAR



Here's a toy that brings to mind all the charm of San Francisco's famed Cable Cars - the clanging bells, the roller coaster hills and the thrill of seeing such sites as Fisherman's Wharf, Nob Hill and Golden Gate Park. Build it as the perfect gift for a favorite child this Holiday season...or for yourself!

The construction of this toy requires a series of simple sub-assemblies, while ready-made wooden toy wheels help make construction even easier. For best results, we recommend that you read through all of the instructions before beginning. Ready? Let's go!

If you're making just one car, prepare a 1/2" x 3-1/2" x 36" long piece of stock by either resawing or thickness planing a 1" x 4" piece of nominal stock to the proper 1/2" thickness. Also, have on hand, a 36" length of 1/4" diameter hardwood dowel -- 6" of 3/4" dowel -- and some 3/4" stock. We used poplar for our example, but clear pine works just as well.

Cut all pieces to size according to the List of Materials, using your Bandsaw or Table Saw. **WARNING:** Since many of the Cable Car parts are small, be sure to use proper safety equipment to control and guide your stock when making all cuts.

Lay out and drill 1/4" dia. by 1/4" deep holes in the Base (A), Roof (B) and Ends (C)...as well as the 1/4" dia. through-holes in the Axle Blocks (J). When laying out the holes in the Base, Roof and Sides, accuracy is important, since the Side Poles must be parallel once assembled.

Drill 3/4" dia. by 1/8" deep holes in the Ends (C) for the Lights (M)...then drill the 1" dia. window holes in the Sides (D), as indicated in the drawings.



Form the contour on the top of the Roof Vent (E), using your Disc or Belt Sander.

Glue and clamp the Axle Blocks (J) to the Axle Spacers (I); the Roof Vent (E) to the Roof (B); the Rear Seats (C) to the Rear Seat Back (F); and the Front Seats (H) to the Sides (D). Once the glue has dried thoroughly, square-up the Front and Rear Seat Assemblies using your Disc Sander.

Check the fit of the Side Poles (K) and Corner Poles (L) in the holes indicated in the Roof, Base and Ends. **NOTE:** Since dowel stock varies slightly in diameter, you may find that it's necessary to taper the ends of the Poles so they will fit easily into the holes for gluing.

Assemble the Ends (C), the Side/Front Seat Assemblies and the Rear Seat Assembly to the Base (A). Make sure all parts are square and clamp them until the glue has dried.

Once the Base Assembly has dried, dry-assemble the Roof Assembly to the Base with the Poles in position to check for proper fit. Glue the Poles, Roof and Base Assembly and clamp until dried. Be sure to allow the glue to dry thoroughly before proceeding.

Sand the Car Sides and Ends flush using the Disc or Belt Sander. **CAUTION:** While sanding, round the corners slightly...but be careful not to round them too much, since the Corner Pole holes are so close to the corners.

Glue the Wheels (N) and Axle Pegs (O) to the Axle Block Assemblies. After the glue has dried for about 10 to 15 minutes, carefully move the Wheels to make sure they don't get glued into place. Be careful not to move the Axle while doing this.

Attach the Wheel Assemblies to the Base with glue. Glue the Lights (M) into place.

Final sand the assembled Car with 100-grit sandpaper, being sure to knock off all sharp edges. Apply a non-toxic finish such as Salad Bowl Finish - or, if you prefer, leave unfinished!



LIST OF MATERIALS -(finished dimensions in inches)

A	Base (2)	1/2 x 3 x 8
B	Roof (1)	1/2 x 3 x 8
C	Ends (2)	1/2 x 3 x 1-1/2
D	Sides (2)	3/8 x 2-1/2 x 3
E	Roof Vent (1)	1/2 x 1-3/4 x 7-1/4
F	Rear Seat Back (1)	1/2 x 1-1/2 x 2-3/4
G	Rear Seats (2)	3/4 x 3/4 x 2-3/4
H	Front Seats (2)	3/4 x 3/4 x 2-1/2
I	Axle Spacers (2)	1/2 x 1-1/4 x 1-1/2
J	Axle Blocks (2)	3/4 x 1-1/2 x 2-1/4
K	Sides Poles (6)	1/4 dia. x 3-1/2 long dowels
L	Corner Poles (4)	1/4 dia. x 2 long dowels
M	Lights (2)	3/4 dia. x 3/8 long dowels

Miscellaneous:

N 1-1/2" dia. Wooden Toy Wheels (8)

O 1/4" dia. Axle Pegs (8)

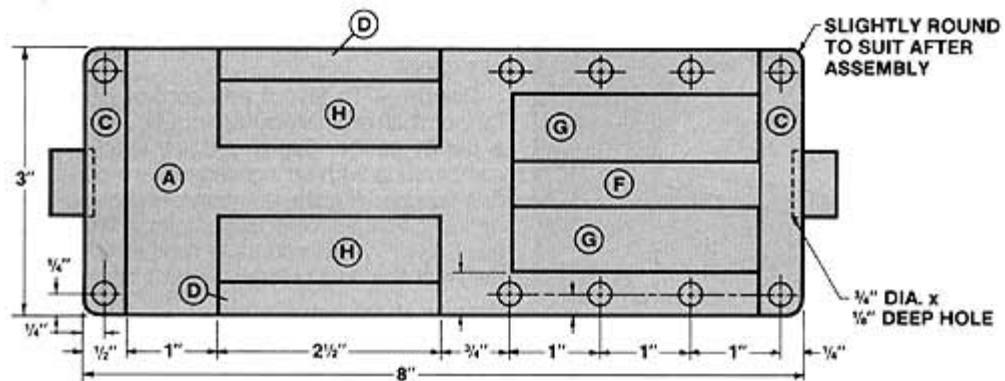

BASE LAYOUT

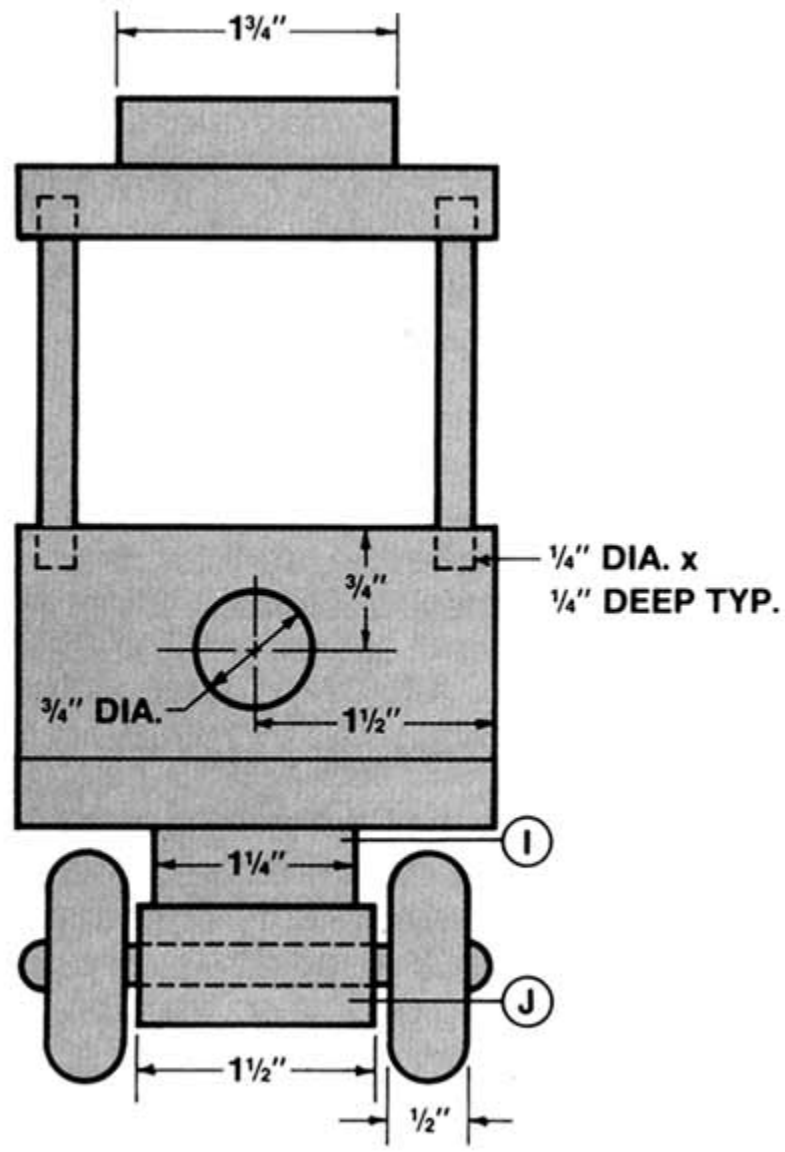

END VIEW

TWO SHELF SIDE TABLE



We know....today, everybody has a cell phone attached to their belt, the side of their purse and even the dashboard of the car. After all, this IS the "mobile society", isn't it? Well....yes....but there are always those "hold-outs" who prefer to have a number of hard-wired phones distributed conveniently around the house.

Question is....where do you put them? Not every room has a convenient place for a phone...and even fewer yet have room to keep a phone book and notepad in close proximity. Enter this dandy little stand from the '80's. Even if you decide not to try and market these stands for use with the telephone, they'll also make great Side Tables for a small lamp and some reading materials.

So....before we get started, let's talk briefly about three things:

DESIGN

As you can see, our stand is really quite simple...almost "Shaker-Like" in its design. However, with just a few simple changes, its appearance can be altered completely. Change the handle cut-outs to a heart shape for a



"Country" look...or even use a more elaborate fretwork design of your own. Create a "Mission" look with tapered Sides and re-designed "legs". Cut the Sides off flush with the Top Shelf for a more contemporary look. Change the appearance of the Shelf Facings. Add a shelf for more utility. The options are endless.

JOINERY

The second of these three points has to do with the way this project goes together with sliding dovetail joints. In our example, we used "stopped" dovetails that are only visible from one side of the project. However, these could just as easily be full "through" dovetails where the joinery shows prominently from both sides. You might even consider making the Sides of maple and the Shelves of walnut to give your dovetail joinery a contrasting look. Another (much simpler) option would be to use straight dado joints instead of dovetails.

MULTIPLICITY

The final point has to do with the fact that each Stand/Table is quite simply comprised of only seven separate pieces of wood, cut into just four sizes. That's it. And that means you can build a bunch of these tables in almost the same amount of time that it would take you to make just a couple. The secret lies in the efficiency of your machine set-ups. With our example, you'll have just four ripping set-ups (12", 11-5/8", 2-1/2" and 1-1/2")...and four crosscut set-ups (31", 16-1/2" and 16").

For added efficiency, try "pad-sawing" the Side shape cut-outs and leg shapes in pairs if you're using your Scroll Saw or in stacks of up to six if you've designed them so you can use your Band Saw without having to make a "piercing" cut. You can hold your multiples together temporarily during this process by using some high-strength Double-Stick Tape. So, let's get started on building the design shown here.

Cut all stock to size, according to the Bill of Materials.

Use a Router Table with a 3/8" Dovetail Bit to cut the four 3/8" stopped dovetail grooves (11-3/8" long) in Sides (A) as shown in Fig. 1. Be sure to start both dovetail grooves at the rear of the Sides (A).

Cut the matching four dovetails on the ends of the Shelves (B) as shown in Fig. 2.

Using a Router set-up with a 3/8" Round-Over Bit, round over the front edges of the Shelves (B).



Using your Bandsaw or Scroll Saw, round off the tops of the Sides (A) and cut out the openings at the bottoms (that form the legs). Use Your Drum Sander to smooth the inside edges.

Drill starter holes in Sides (A) at their tops where the decorative areas are to be cut out (See Fig. 1). Use your Scroll saw to cut out the openings.

Cut the decorative edge on the fronts of the Shelf Facings (C). We used a Shaper Set-up with a Bead & Bevel Cutter (See Fig. 3).

Assemble the Shelves (B) to the Sides (A) using the dovetails, glue and some clamps. Wipe away any excess glue immediately with a damp cloth.

Install the Shelf Facings (C) and the Bottom Shelf Back (D) with glue and clamps. **NOTE:** The two Shelf Facings (C) should be attached flush with the fronts of the Shelves (B).

Finish with a stain of your choice. Suggested retail price: \$25 to \$80 each, depending on woods used, design and finish.

LIST OF MATERIALS –(finished dimensions in inches)

A	Sides (2)	3/4 x 31 x 12
B	Shelves (2)	3/4 x 16-1/2 x 11-5/8
C	Shelf Facings (2)	3/4 x 16 x 2-1/2
D	Bottom Shelf Back (1)	3/4 x 16 x 1-1/2

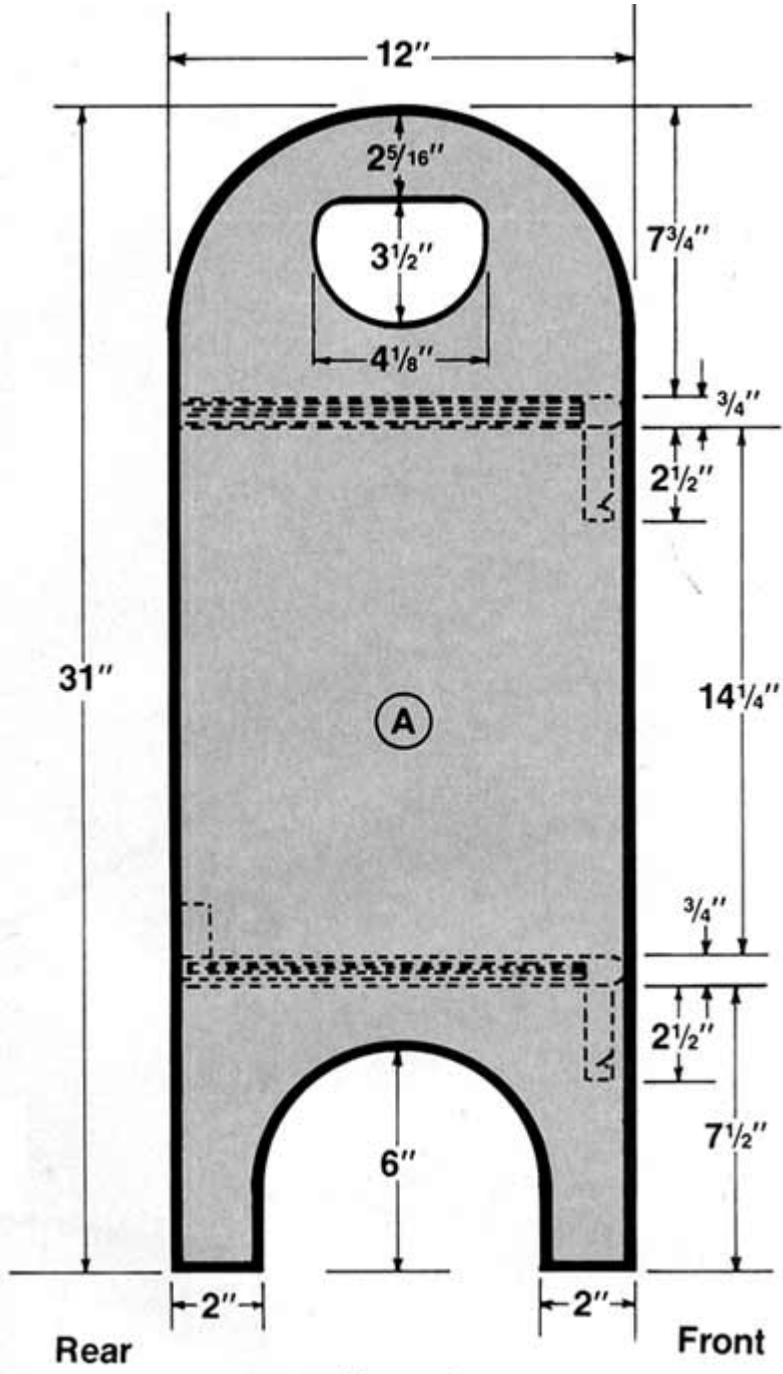
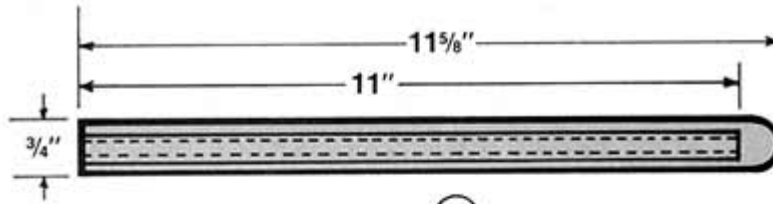

Figure 1



(B)

Figure 2

Rear

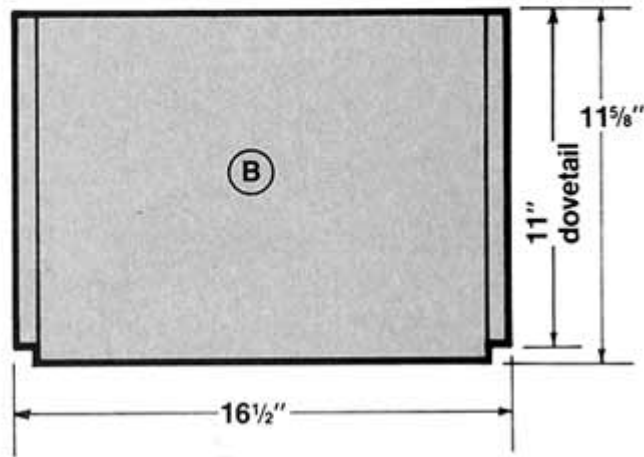

Front

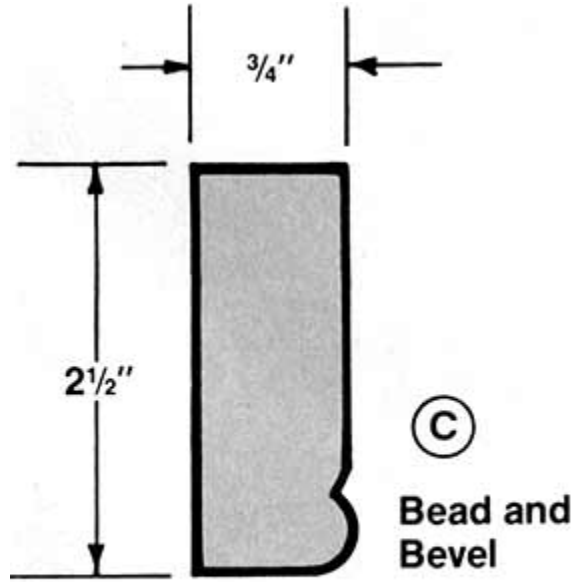
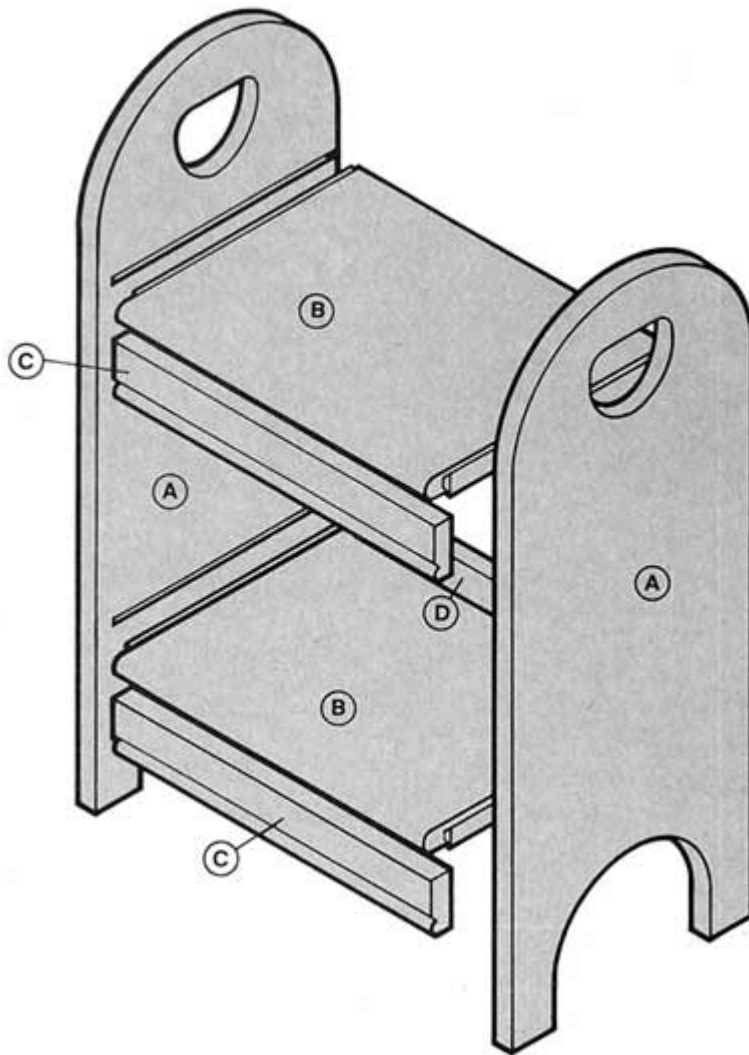

Figure 3
end view



THE OUTDOOR DECK CHAIR

Here's a simple, rugged outdoor chair design that you can easily modify to suit your own needs.



If you've already decided that cheap, plastic outdoor furniture isn't for you...and you've already priced well-designed wooden outdoor furniture, you can probably figure out pretty quickly that you'll be way ahead of the game if you build it yourself.

This chair plan gives you the opportunity to do just that. Plus...if you use the right materials, these chairs should provide a lifetime of great service, along with the great satisfaction that comes from having built them yourself.

And, with just a few simple dimension changes, the chair could easily become a lounge chair or even a love seat. Change a few more dimensions and you could even have a bench sofa (but you must increase the thickness of your seat slats to 1-1/8" to ensure adequate strength).

Let's start with a little talk about materials. We built our example chair from (selectively picked) number two white pine. Why?, you ask. First of all, we wanted you to know that with today's finishes, the material you choose isn't as important as it used to be.

There are loads of weatherproof finishes out there that will provide many long years of durable service (with a little or no maintenance). Ours is treated with a transparent penetrating oil stain that's especially formulated for outdoor use. Better quality stains such as ours contain additives that



repel water, resist mildew and protect the wood from the harsh Summer sunshine.

As a result, you don't really have to buy more costly, weather-resistant woods for projects like this chair. However, good outdoor woods such as redwood, Western red cedar, cypress or teak have a lot to offer beyond mere weather resistance. They can also be stronger with far more attractive natural colors and grain patterns. That's one decision you'll have to make for yourself.

So, Let's Get Started.

1. Cut all stock to size, according to the Bill of Materials. NOTE: Make any size adjustments now if you're planning to build your own variation of our chair. When selecting lumber, for reasons of strength, care should be taken to avoid knots, especially with treated lumber.

When cutting slats to length, a Miter Gauge Extension Face with an adjustable stop will significantly speed the cutting process and help ensure that all slat lengths are uniform.

2. Use a Shaper or Router set-up to radius two edges of the seat supports (B). A 1/2" radius is preferable, but a smaller radius is also acceptable.

3. Transfer the patterns (from the plan grid) for back supports (A) and seat supports (B) to a large piece of paper. Lay the back and seat supports on the pattern and mark, cut, drill, glue, dowel and clamp the two pieces together at the correct angle to fit your pattern.

4. Using your Bandsaw or Scroll Saw cut the newly created "side" (consisting of the back support [A] and seat support [B] sub-assembly) to shape. Sand and prepare for final assembly.

5. Transfer the pattern for the front legs (C) and back legs (D) to paper. Lay the front and back legs on the pattern and cut; drill for end dowels; and sand for final assembly.

6. Drill, glue and dowel the legs (C&D) to the side sub-assemblies at the proper angles, according to the pattern.

7. Attach the side/leg assemblies to the spreaders (E) with 3/8" dowels (G) and glue. Use extra care at this stage to ensure squareness.



8. Attach the slats (F) to the back supports (A) with screws (H). Use 1/2" wood block spacers to be sure the slats remain parallel to one another and at 1/2" intervals during assembly. Remove the spacers following assembly.

NOTE: If you decide to add arms to your chair, make the following changes:
Add 4-1/4" to the 14" length of the front legs (C)
Add (8) dowels to the Bill of Materials

Cut out two arms 3/4" x 5" x 22" (remember to flip the pattern over for tracing and cutting out the arms for the opposite sides of your chairs)

NOTE: If arms are installed, legs (C) must be doweled on the outside of the seat support (B) rather than the inside...and a couple of seat slats will have to be trimmed to accommodate the arm support.

LIST OF MATERIALS:

(finished dimensions in inches)

A	Back Supports (2)	3/4 x 6 x 28
B	Seat Supports (2)	3/4 x 6 x 21
C	Front Legs (2)	3/4 x 3-1/2 x 14
D	Back Legs (2)	3/4 x 3-1/2 x 12
E	Spreaders (2)	3/4 x 3 x 18
F	Slats (20)	3/4 x 2-1/4 x 22
G	Dowel Pins (26)	3/8 diam x 1-1/2
H	Screws (40)	#8 x 1-1/4" Flat Head Stainless Wood Screws

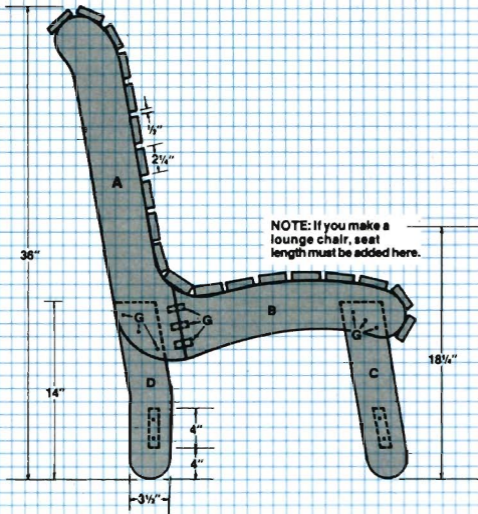

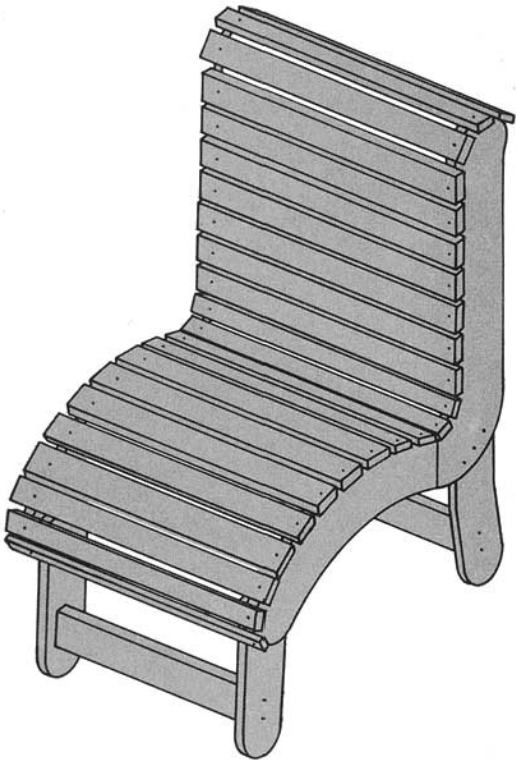

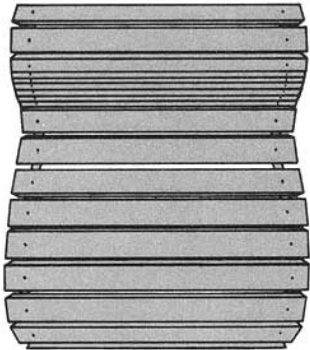

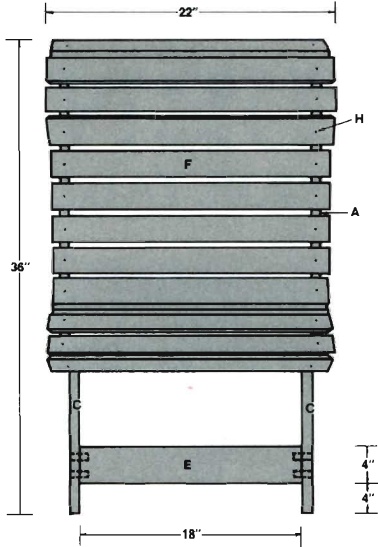

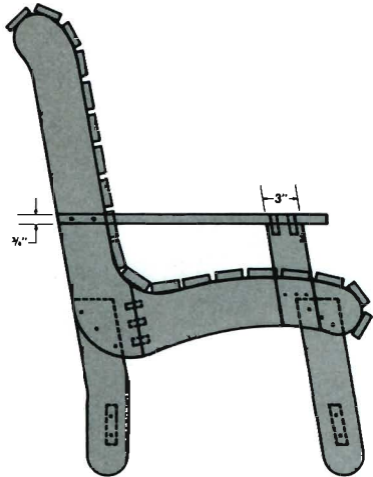

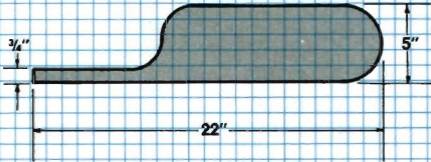

BANDSAW BOXES

Quick and easy to build -- with a "one-of-a-kind" flair that makes them sell fast, too



Bandsaw boxes are novel in their design, deceptively simple to build and make perfect jewelry, trinket or keepsake boxes. And the best part of all is that you don't need a bunch of fancy joinery tools to build them. Just a Bandsaw.

Their cleverness lies in the guaranteed snug fit of the drawers in the box. This is possible because the drawers are actually cut from the box carcass...so, naturally, they'll fit right back into the space they came from. Plus, you won't have to worry about miss-sizing any complex joinery, since the only gap between the drawer and its surrounding box will be the width of the kerf the bandsaw blade takes as it cuts out the drawers.

Just as the Bandsaw can cut practically any irregular shape, so can Bandsaw boxes be made in any shape. Drawers can be traditional rectangles...or circles, ovals or virtually any shape that suits your fancy.

A box can contain one drawer or several. In fact, you could almost go so far as to say that no two Bandsaw boxes are ever alike, since they are typically made out of small pieces of scrap wood in any shape. That's how the boxes pictured here were made. The small box is made from laminated cherry and the large box is laminated alder. There's only one limitation. Box sizes are restricted to the 6" capacity of the Bandsaw...and that's about it.

Although any Bandsaw blade may be used, you will obtain tighter fits between the drawers and the carcass by using smaller blades. The boxes shown here were cut with a 1/4" blade. Smooth cuts mean less sanding, which also contributes to tighter fits with the drawers.



The instructions and photos here describe the step-by-step procedure for cutting a two-drawer box. Build yours out of whatever size of solid wood or laminated pieces you can lay your hands on and enjoy designing your own one-of-a-kind creation.

Preparation

Start by cutting your wood block to size - or by laminating a series of pieces together to create the size block you want. Remember not to exceed your 6" Bandsaw limit on any one side or dimension of the box. Round your corners with a Router set-up or Belt Sander and do any shaping at this time, then sand the box smooth with 220-grit sandpaper. The shaping and sanding are done now because the box will be much more stable at this time than it will after it's cut.

Cutting the sides

Cut off both sides of the box. They'll be glued back on later, once you've cut out the drawers. The sides of our box are 1/2" thick, but you could safely go down to 1/4", if you prefer. You'll notice that we're using our Miter Gauge (clamped to the Bandsaw Table) as a Fence. If you have a newer model Shopsmith Bandsaw, just use your Bandsaw Rip Fence. (See Fig. 1)

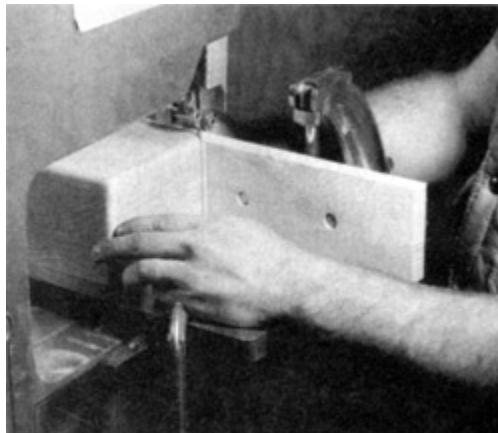

Marking the drawers

Once you've removed the sides, use a square to lay out the drawers on the front and side of the box carcass. On our two-drawer box, we allowed 1/2" thickness for the bottom of the box, the top, the back and the drawer separator. For lighter boxes, you may reduce these measurements to as small as 1/4". (See Fig. 2)

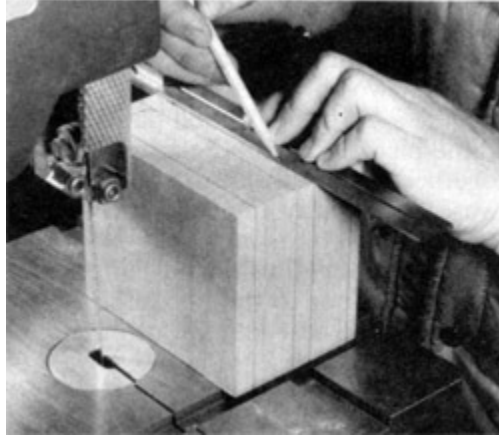

When determining your drawer depth, allow 1/4" to 3/8" for the thickness of the drawer bottom. Here, you're left with drawers 7/8" deep. Make the fronts and backs 3/8" to 1/2" thick. When you draw your drawer lines, be sure the corners are rounded and not square. Remember the turning radius of your blade when you make your corners: 1/4" for 1/8" Blades - 3/8" for 3/16" Blades and 1/2" for 1/4" Blades.

Cut the first drawer

Use your Miter Gauge and Rip Fence for the straight sides. Stop when you get to the corners and remove the Miter Gauge. Cut the corners freehand, then replace the Miter gauge and cut the other side. (See Fig. 3)

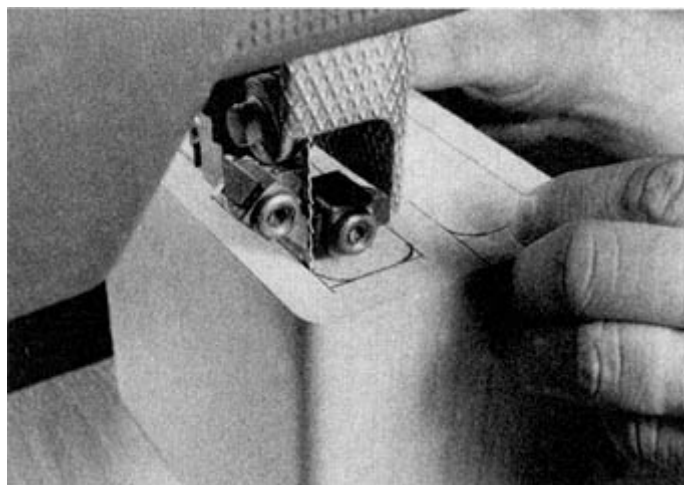

Cut the second drawer

Accuracy is extremely important when you cut the drawers, so work slowly and carefully. (See Fig. 4)

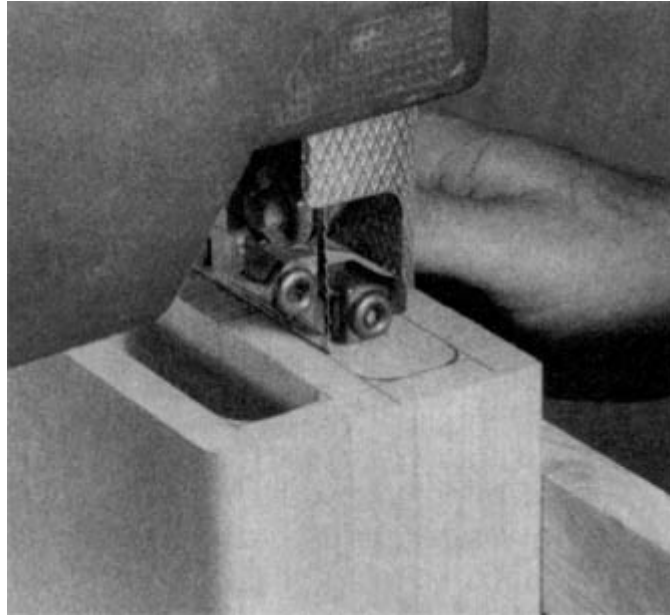

Assess your progress

Here, you see the box carcass after both drawer blanks have been removed. The depth of each drawer opening is 1-1/4" and the drawers will be 7/8" deep. To accommodate larger pieces of jewelry, this same size box could be made with just one drawer. In this case, the finished drawer would be about 2-1/2" deep. (See Fig. 5)

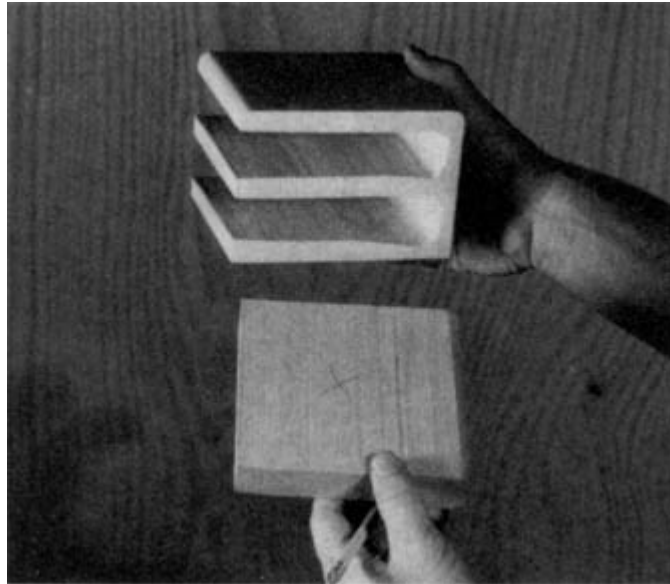

Cut the drawer sides

Put the drawer blanks on the Bandsaw and cut off the sides. the thickness of these drawer sides is $\frac{3}{8}$ ". Mark each drawer and the sides after they are cut so that later, you'll be able to match them up when you glue them back together. **This is important.** (See Fig. 6)

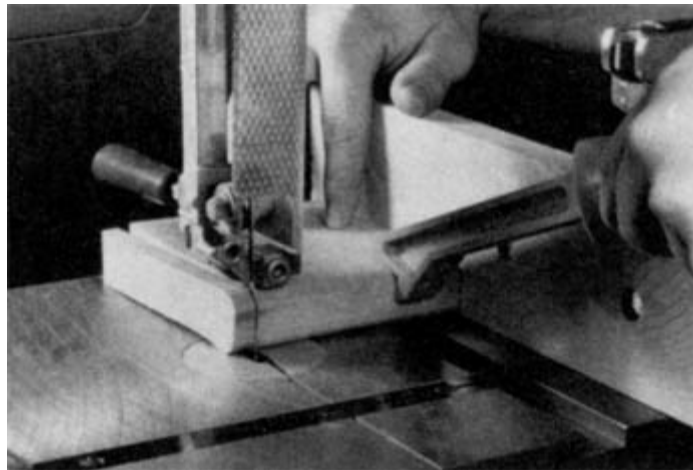

Mark the drawers

Draw lines on the sides of the drawer bodies to indicate the front, bottom and back of each drawer. In this case, they are all $\frac{3}{8}$ " thick. Once again,

remember to round the corners so your blade can make the turns. (See Fig. 7)



Cut out the drawer bodies

Follow the lines you drew and cut out the insides of the drawers. Once removed, the insides can be discarded. (See Fig. 8)



Finish the drawers

Do any light sanding on the drawer pieces at this time because it's easier to sand the insides before they're re-assembled. Then, glue the sides of the

drawers back onto the bodies. Once the glue has dried, lightly re-sand the glue joints. (See Fig. 9)

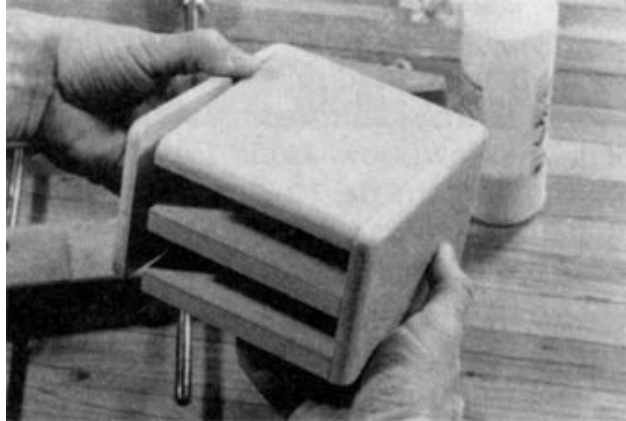

Finish the carcase

Do any light sanding to the inside of the carcase at this time. It will be easier to reach your fingers inside the drawer holes before the sides are glued on. Then, glue the outer sides of the box back onto the carcase. Once the glue has dried, re-sand the glue joints. Your Bandsaw box is now finished and ready to be stained, oiled or varnished - and to have drawer pulls attached.

Another Example

This photo shows how the construction differs for a one-drawer box. Fig. 10)

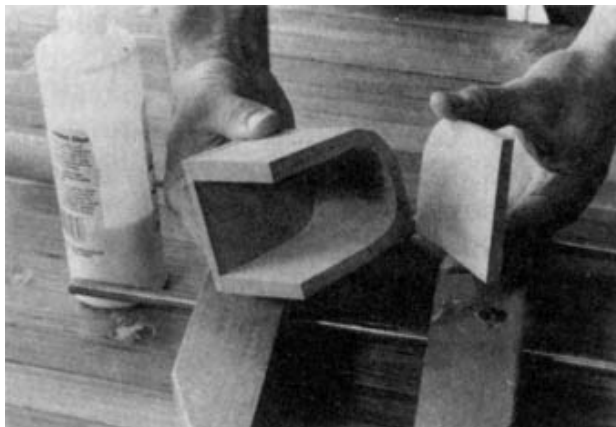

Suggested retail price: \$20 to \$30 each , depending on wood





THE HEIRLOOM CRADLE

A wooden canopy and turned rocking treadles make this cradle truly unique.



There's something very comforting about a wooden cradle...its gentle back-and-forth movement can be almost as soothing to a parent as it is to a baby.

Since we receive so many requests for cradle project plans, we decided to expand upon the more traditional baby cradle to fulfill your modern-day needs. A delicately arched canopy shields the baby's sensitive eyes from harsh light, while the twin, turned treadle bars allow you to rock the cradle with one foot while relaxing in your favorite easy chair.

Making the Cradle

To make the cradle, you'll need 32 feet of 1" x 8" (actually 3/4" x 7-1/4") lumber and 18 feet of 1" x 6" (actually 3/4" x 5-1/2") lumber, plus dowels, brads and flathead wood screws.

Start by cutting and jointing the lumber to the approximate size boards needed. Cut them a little oversized to allow for squaring.

Next, edge glue a series of boards together to form the wider panels you'll be needing for assembly. For added strength and to maintain proper alignment during glue-up, you might want to consider using a Biscuit Joiner with the appropriate sized Biscuits.

For each side (A), edge glue two 3/4" x 7-1/4" x 41" boards and a 3/4" x 7-1/4" x 18" board.

For the headboard (B), edge glue three 3/4" x 7-1/4" x 19" boards.

For the footboard (C), edge glue two 3/4" x 7-1/4" x 16" boards.



For the base, edge glue two 3/4" x 5-1/2" x 37" boards and a 3/4" x 7-1/4" x 37" board

Glue up the stock you'll be needing to turn the treadle bars (J) and end caps (K). For the treadle bars, glue up three 3/4" x 2-1/4" x 26" boards for each treadle bar. For the end caps, glue up three 3/4" x 2-1/4" x 10" boards to make one blank for turning all four of the end caps.

The rockers (H), canopy support (E) and canopy pieces (F,G) are cut from the remaining stock.

While the glue dries on the assembled boards, cut enough stock to width and length to make the canopy pieces (F,G). Then use a Bandsaw to resaw the pieces to 1/4" thickness (See Fig. 1).

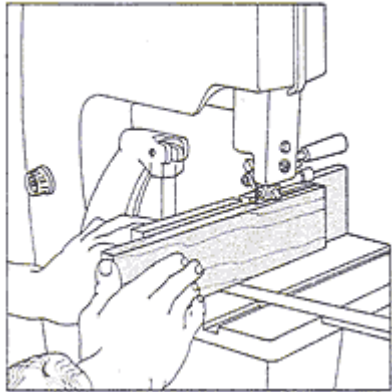

Fig. 1 Using a bandsaw to resaw stock.

Next, use a Table Saw and a Hollow Ground Blade or a Jointer to cut a slight 2-degree edge bevel along the length of each piece, so the pieces will form a smoothly arched canopy when assembled.

With your Bandsaw, cut the rockers (H) and canopy support (E) to size and shape, according to the drawings. To make sure both rockers are exactly the same shape, pad saw the two workpieces by double-stick taping them together and sawing both pieces out at the same time (See Fig. 2). Be sure to leave your cutting line intact while cutting.

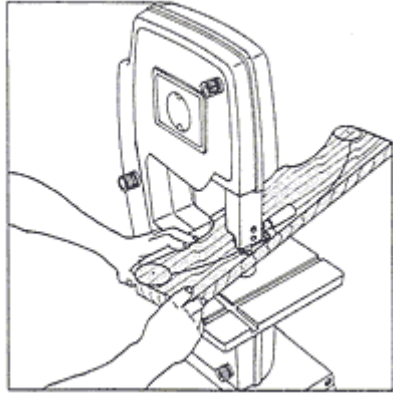

Fig. 2 Using a bandsaw to pad saw rockers to shape.

While they're still taped together, use a Drum Sander to sand them to final shape, then drill two 1" diameter holes in the ends to accept the treadle bars (J).

Once the glue has dried on all of the pieces you glued together earlier, use a Hand Scraper to knock off any excess glue, then belt sand the surfaces of the assembled pieces smooth.

Next, mark the angles and patterns on the sides (A), headboard (B) and footboard (C). A Protractor/Bevel or Precision Protractor will make easy and precise work of this task.

With your Table Saw set up for making bevel cuts...and your Miter Gauge set for making angled cuts, cut all required edge bevels and angled cuts in the various pieces. Next, use a Scroll Saw or Sabre Saw to create the circular cut-outs in the sides. Use a 1" dia. Brad Point Bit to drill the ends of the handle cut-outs, then your Scroll Saw or Sabre Saw again to remove the remainder of the stock. Remember to stay outside your cutting lines so you can smooth the handle edges with a small diameter Drum Sander once you've finished cutting them out.

Use your Bandsaw to cut out the pattern for the footboard (C). Cut the base (D) to size on your Table Saw, then shape the edge of the base using your Router Set-up with a 1/4" Router Chuck and a Roman Ogee Bit. **IMPORTANT:** To avoid splintering in the corners, always remember to rout the end grain first...then the edge grain.

Once the glued-up stock for the treadle bars (J) and end caps (K) has dried for 24 hours, use your Lathe to turn these pieces to shape. Remember that your four end caps (K) are to be turned from a single piece of glued-up stock. Smooth sand and finish sand the treadle bars and end caps at slow speed while they're still mounted on the Lathe.



Now, drill a 1/4" diameter by 1/2" deep dowel hole in each end of each treadle bar...and the adjoining ends of each end cap, using a Tailstock Chuck Arbor , your Drill Chuck and a 1/4" diameter Brad Point Bit. See Fig. 3.

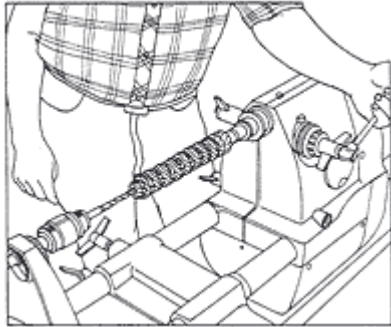

Fig. 3. Drilling dowel holes in the end cap.

Sand all remaining pieces smooth. Assemble the sides (A) to the headboard (B) and footboard (C) with glue and counterbored 1-1/2" - #8 flathead wood screws (L).

Span the canopy support (E) between the sides (A), then glue and screw the upper support into place. Using glue and counterbored 1-1/2" - #8 wood screws (L), attach the base (D) to the bottom edges of the sides, headboard and footboard.

Use brads (P) to assemble the canopy pieces (F,G) to the cradle. Start in the center with narrower 1/4" x 1-1/4" x 14" pieces and work your way to the ends. The 1/4" x 3" x 14" pieces are attached on the ends. Sand the canopy top for a smooth, rounded contour.

Insert the ends of the treadle bars (J) through the holes in the rockers (H). Attach the end caps (K) with 1" x 1/4" dowels (N) and glue into place. Attach the rockers to the bottom of the base (D) with glue and counterbored 1-1/2" - #8 flathead wood screws (L).

Cover all counterbored screws with 3/8" diameter x 1/4" dowel plugs (M). Sand the plugs flush, then finish sand.

Since the cradle is to be used for a baby, be sure to use a non-toxic finish such as Salad Bowl Finish or Preserve Oil Finish.



LIST OF MATERIALS –
(finished dimensions in inches)

A	Side (2)	3/4 x 21-3/4 x 40
B	Headboard	3/4 x 21-1/2 x 17-3/16
C	Footboard	3/4 x 13-1/2 x 15-1/4
D	Base	3/4 x 15-1/2 x 36
E	Canopy Support	3/4 x 4 x 17-3/16
F	Canopy Boards (12)	1/4 x 1-14 x 14
G	Canopy Edge (2)	1/4 x 3-1/2 x 14
H	Rocker (2)	3/4 x 5-1/2 x 28-1/4
J	Treadle Bar (2)	1-3/4 dia. x 26
K	End Cap (4)	1-3/4 dia. x 1-3/8
L	Wood Screws (49)	flathead, 1-1/2 - #8
M	Dowel Plugs (49)	3/8 dia x 1/4
N	Dowels (4)	1/4 dia. x 1
P	Brads (1 oz.)	#18 x 1

FOOT BOARD

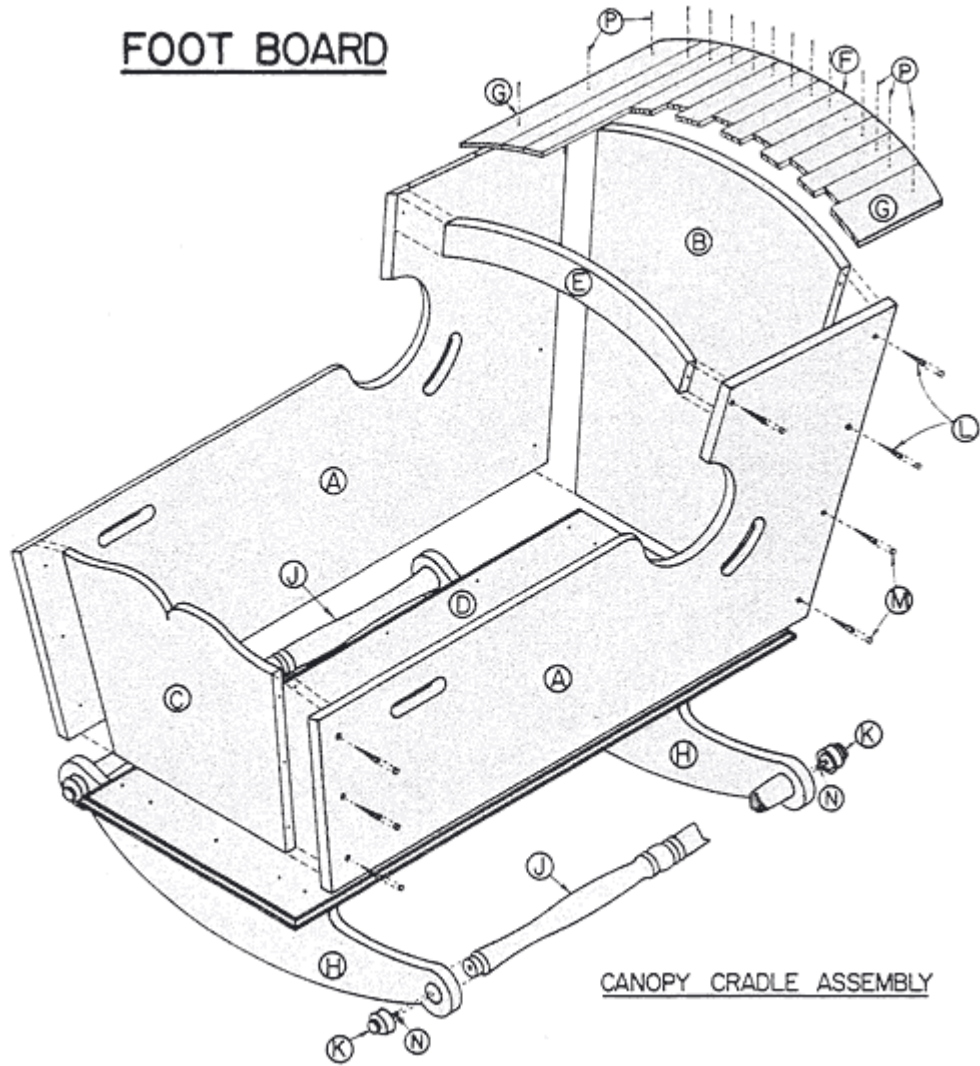

CANOPY CRADLE ASSEMBLY

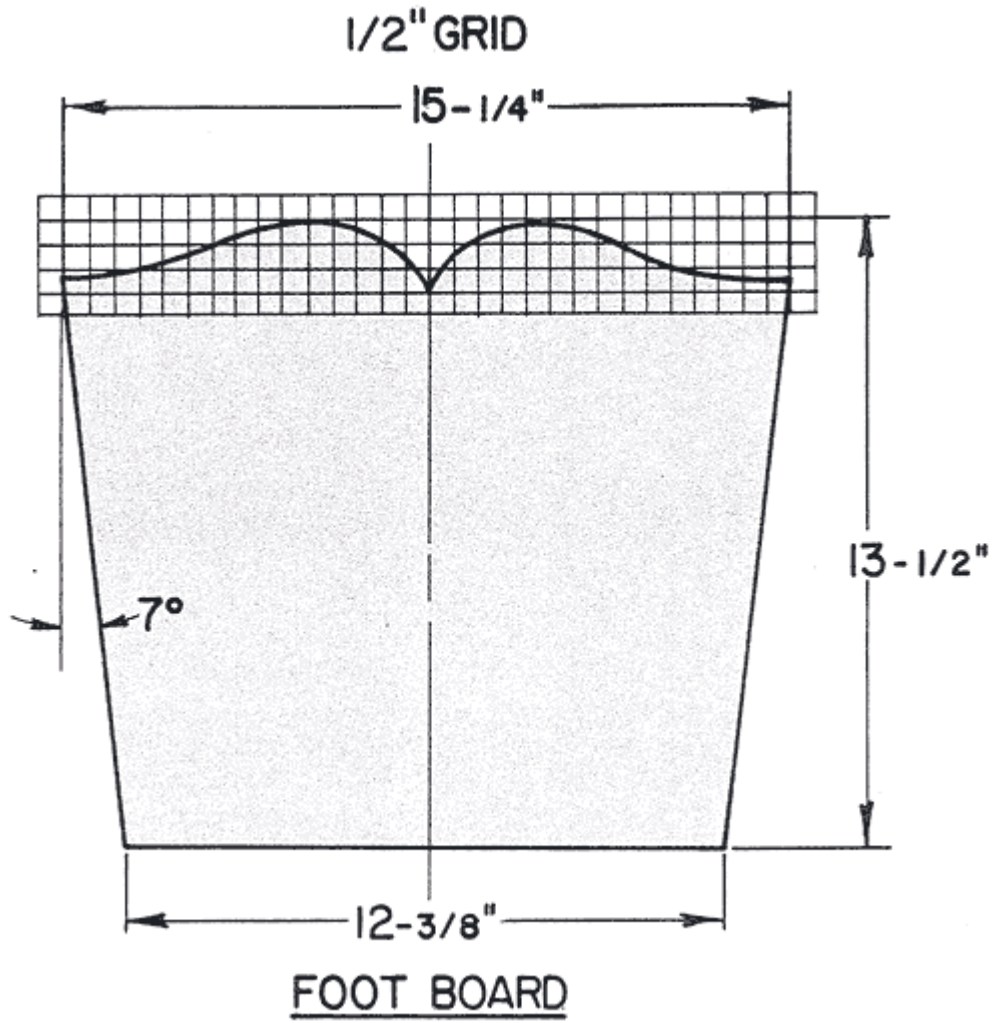

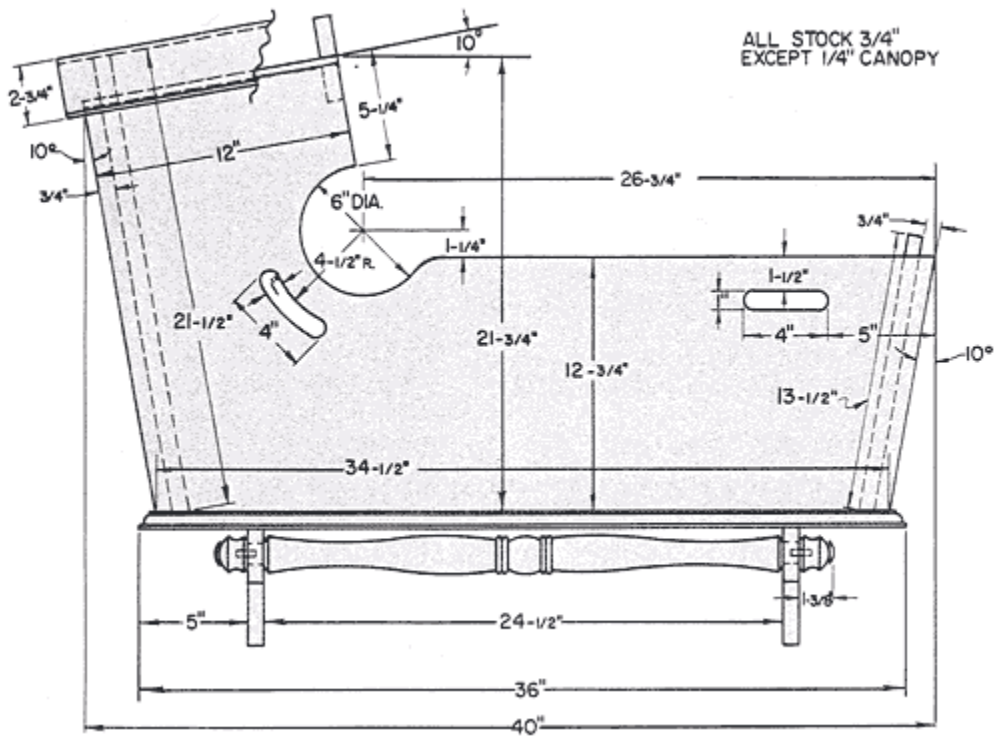

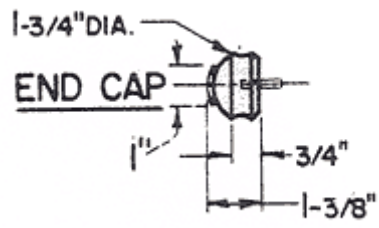

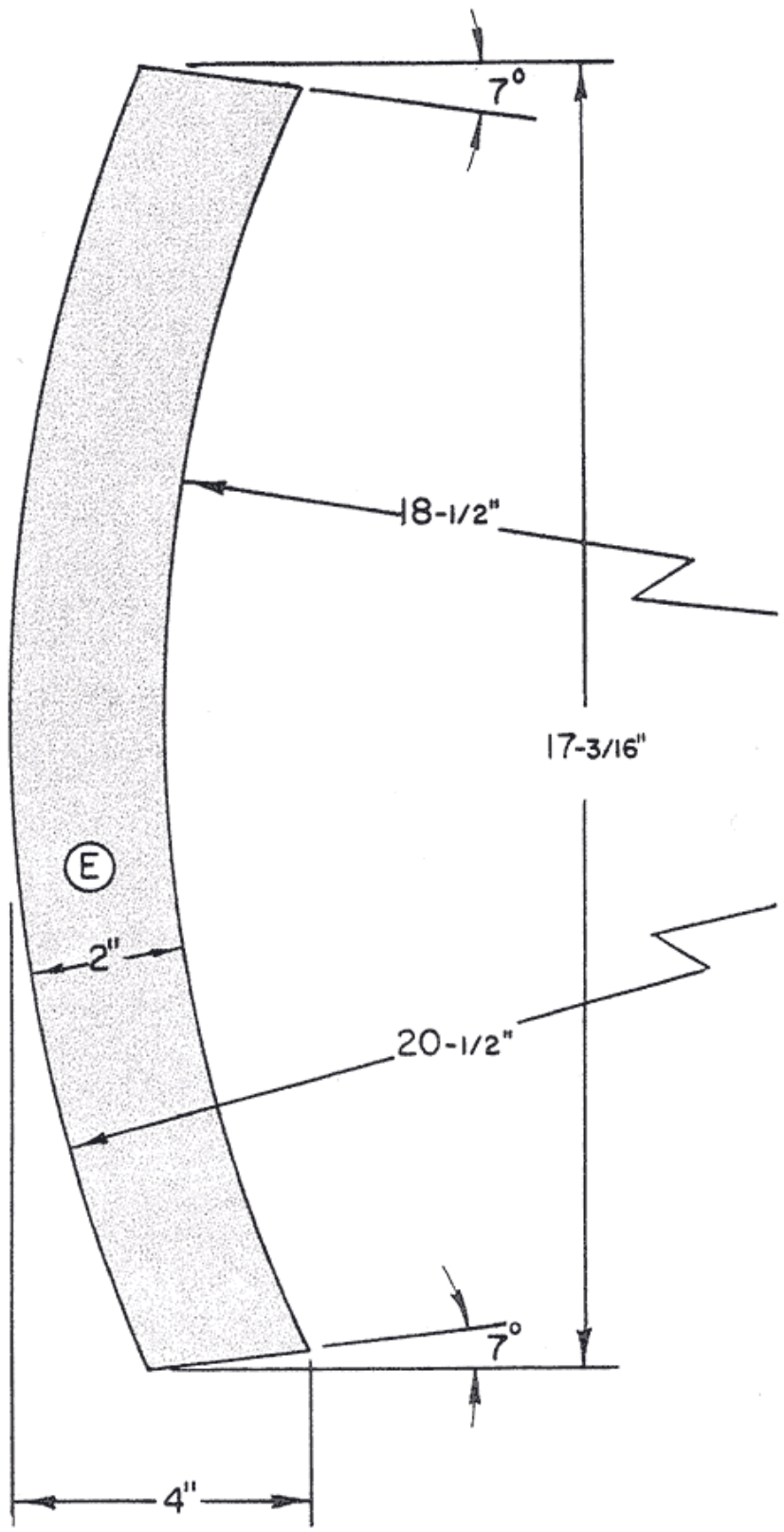

END OF CANOPY

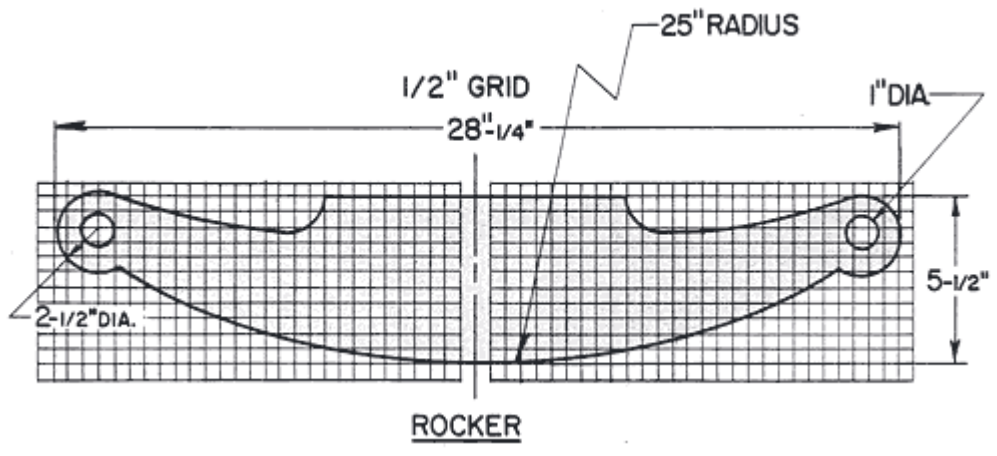

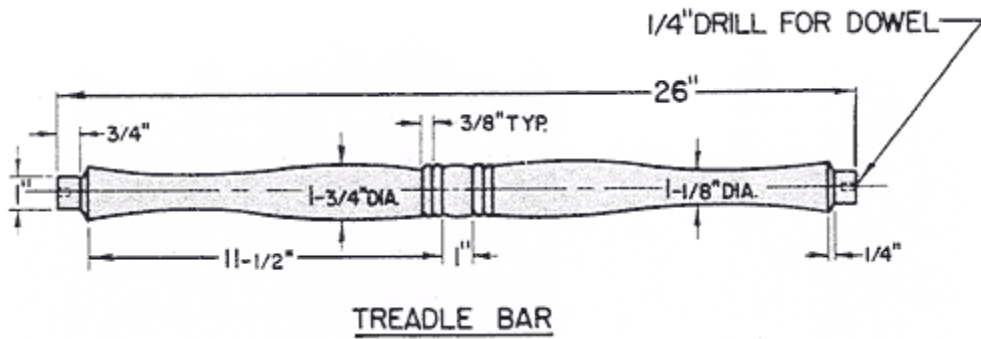

TOY AIRPLANE

A easy-to-build replica of Charles Lindbergh's famous trans-Atlantic airplane!



Having been a Naval Aviator for over 20 years gave Norm Marshall a real appreciation for airplanes. When he retired, he began building toys...and his fascination for airplanes continued. He particularly loved the stories surrounding the historic 1927 trans-Atlantic flight of The Spirit of St. Louis...and recounted how making those toys and remembering those stories gave him double pleasure - an escape into history and an adventure in woodworking.

So...get ready for your solo flight...but keep in mind that you don't have to do this one non-stop!

1: Prepare the stock. Use clear, straight stock (we used pine) and hardwood dowels. Glue-up or use your Bandsaw to resaw stock where required. When resawing stock for the wing (B), tilt the Bandsaw table 5-degrees and cut a 15" length of 1 x 4 stock. Next, rip the stock to a 2-3/4" width.

2: Drill the holes for the engine cylinders (K). Locate them 1/2" back from the front of the nose (See Fig. 1). Tilt the Drill Press table to 20-degrees and drill the holes in the fuselage (A) and the shock absorbers (F) for the wing struts (N).

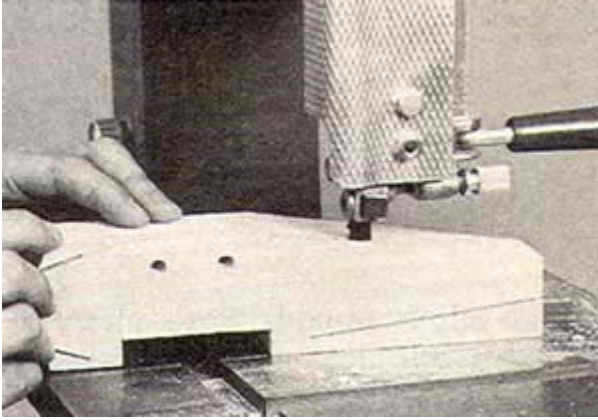

Fig. 1 Drilling the engine cylinder holes 1/2 in. back from the nose.

3: Cut out the contours. Transfer the side and top profiles to the fuselage (A), and draw a 1" diameter circle on the nose of the fuselage. First, form the dado for the wing...then cut the tail slot. Cut out the remainder of the profiles on the Bandsaw (See Fig. 2).

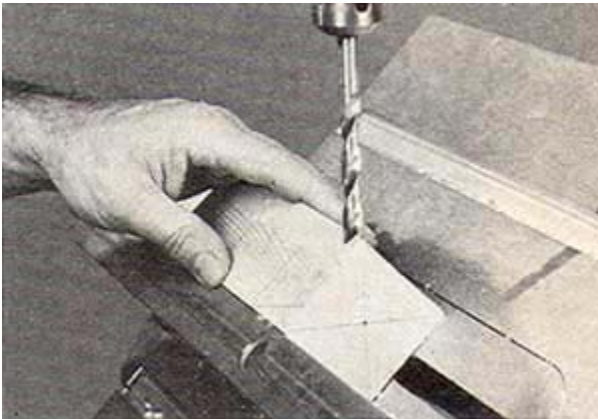

Fig. 2. Cutting out the fuselage profile on the bandsaw.

Transfer the patterns for parts (B, C, D & E) to the stock. Cut out these parts with either your Bandsaw or Scroll Saw, making sure to stay slightly outside your cutting lines.

4: Sand parts A through E to finished shape using your Disc Sander with fine grit paper. Round the nose section of the fuselage so the corners meet the circle. Hand sand part F.

5: Drill holes for the propeller shaft, tail skag, shock absorbers, axles and lock pins.



6: Make the wheels (H). Use a 1-1/2" hole saw to score the wheel rim lines 1/8" deep...then a 1-7/8" hole saw to cut out the wheels.

7: Make the propeller hub/shaft assembly by gluing the shaft (M) into the hub (L). Once the glue has dried, mount the hub/shaft assembly into your drill chuck and sand or rasp it to shape.

8: Assemble the plane. Start by gluing the cylinders (K) into place.

Next, place the wing struts (N) in the fuselage holes (but don't glue them yet). Place a straight edge in the wing slot and mark the outer ends of the struts. Cut the struts to length, then glue them into place.

Using 1/4" axle pins or #12 x 1-1/4" roundhead wood screws, attach the wheels to the wheel struts. If you use screws, be sure to file off any points that protrude through the struts. Glue the struts to the shock absorbers - remember that there are left and right wheels. Use the 1/8" hole in the shock absorbers as pilot holes and drill the struts for the lock pins (G). Glue pins (G) into place.

Glue and clamp the wing, rudder, stabilizer, propeller and tail skag into place.

9: Finishing touches. If you want to paint your plane, be sure to apply the proper filler first, then use silver or light grey on the fuselage and flat black on the cylinder heads and tires. Letters and numbers can be cut from adhesive-backed paper.



LIST OF MATERIALS -
(finished dimensions in inches)

A	Fuselage	2-1/4 x 2-1/4 x 10
B	Wing	1/2 x 2-3/4 x 15
C	Stabilizer	1/4 x 2-1/4 x 6-1/4
D	Rudder	1/4 x 2-3/4 x 2-3/4
E	Propeller	1/4 x 1 x 7
F	Wheel shock absorbers (2)	3/4 x 1-1/4 x 1-3/4
G	Shock absorber lock pins (2)	1/8 dia. x 3/4
H	Wheels (2)	1-3/4 dia. x 1/2
J	Wheel struts (2)	7/16 dia. x 2-1/4
K	Engine cylinders (8)	3/8 dia. x 3/4
L	Propeller hub	1 dia. x 3/4
M	Propeller shaft	1/4 dia. x 1-3/4
N	Wing struts (4)	5/16 dia. x 5
P	Tail skag	5/16 dia. x 1-3/4
Optional: #12 x 1-1/4" roundhead wood screws (2)		

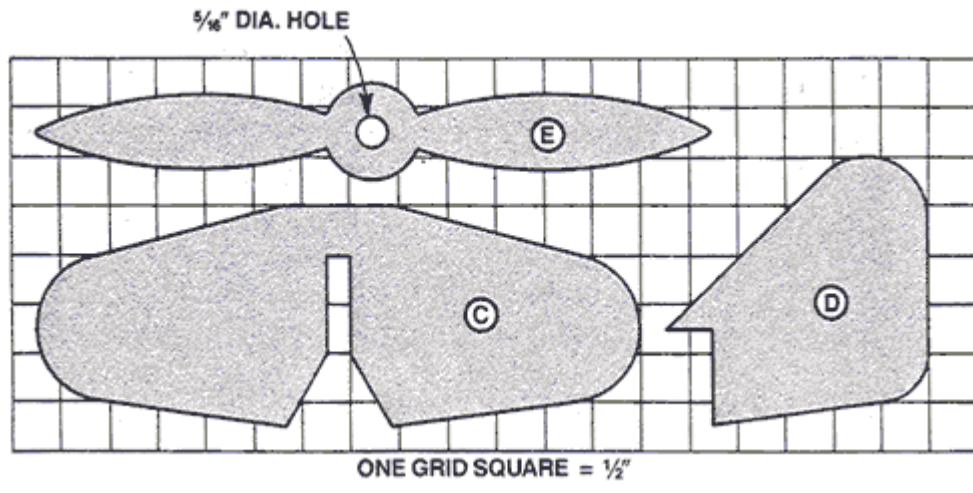

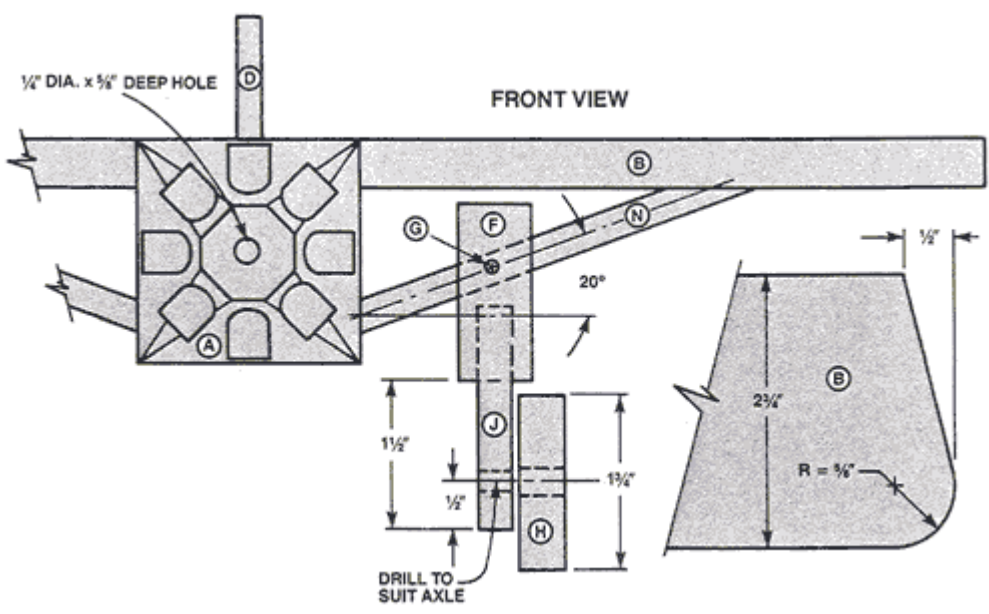

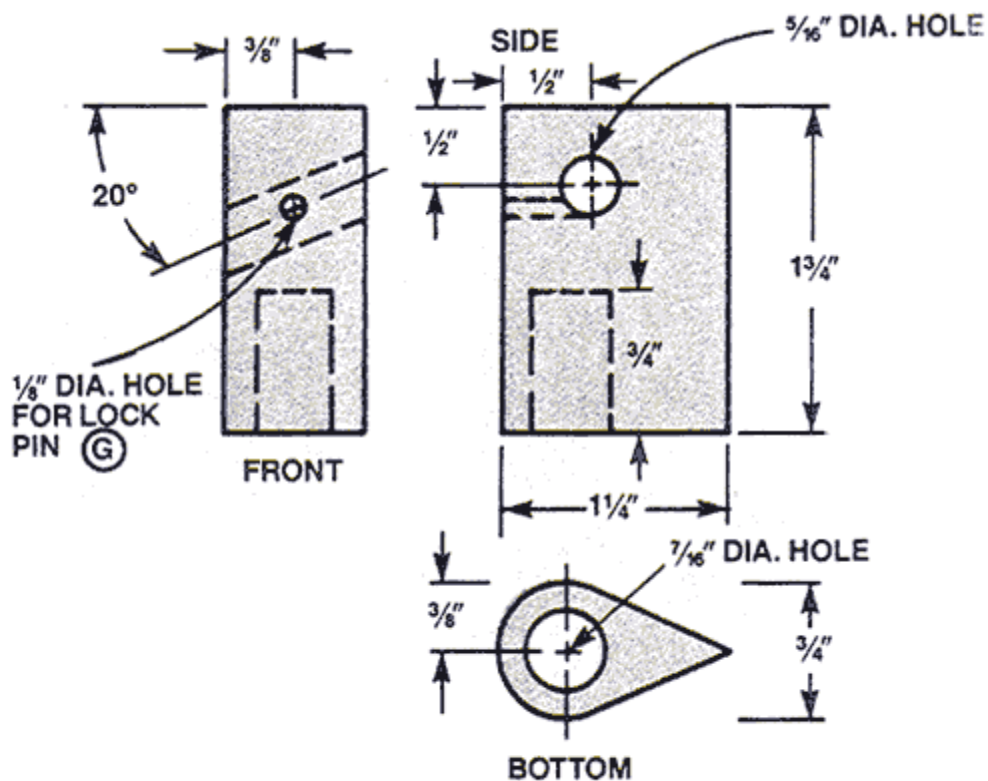

(F) SHOCK ABSORBER DETAIL

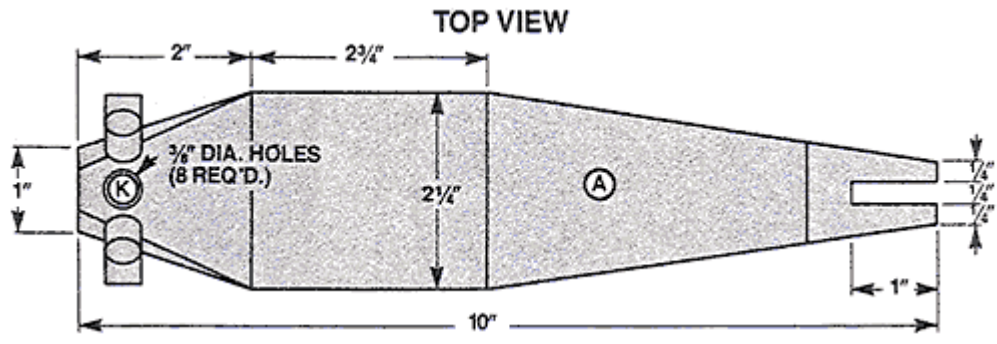

ALL PURPOSE WOODEN BOXES

A great jig for making multiple boxes...and step-by-step instructions for making a simple 3" x 5" x 8" all-purpose box.



The next time you're faced with making several gifts for friends and/or relatives for the Holidays ...or any time of the year for that matter...consider the benefits of mass production techniques.

And the best way to reap the benefits of mass production is by using specialized jigs and fixtures that help you perform a variety of operations quickly and easily, with significant improvements in repeatability.

Since wooden boxes have always made popular gifts, we've developed this simple jig to quickly and easily make multiple box parts. The variations are endless. Choose different woods. Alter the sizes. Partition the interiors or not. Hinged or removable top. It's easy to make your boxes as individual as you like.

Start by building this easy-to-use jig...then use it to build the boxes of your choice.

IMPORTANT NOTES: This jig was designed to make boxes with 45-degree mitered corners.

Our example jig was originally built to work with a Model 500 Shopsmith MARK V. Dimensions will vary for Model 505, 510 and 520 machines...so you'll have to adjust the dimensions accordingly.

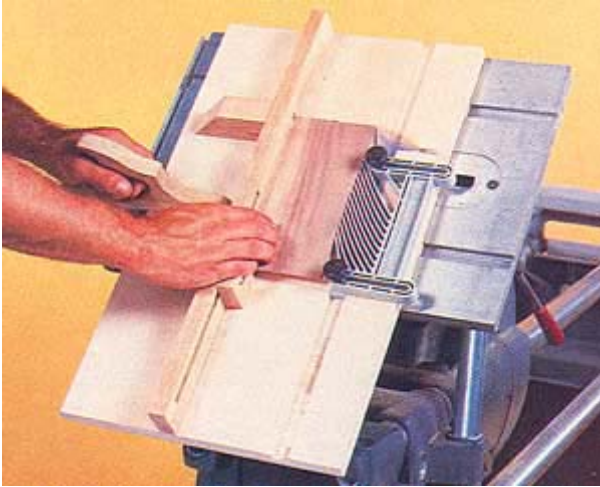

Making The Jig

1: Accuracy is essential, so check all of your machine alignments before you get started.

2: Cut the guide strips (**B**). Make them out of a durable hardwood such as hard maple, oak or ash. Note that the width and thickness of these strips will vary from machine-to-machine, so be sure to measure your Miter Gauge slots carefully before cutting the strips.

3: Cut the plywood table (**A**) to size. We recommend that you use 3/4" plywood for stability. A high-quality, multi-layered Baltic Birch or Apple-Ply product without unsightly voids is best. Next, lay your guide strips (**B**) in the saw table slots, then lay your jig table on top of thee with the left edge of the jig table flush with the left edge of your saw table. Drive some small brads through the jig table top and into the guide strips. NOTE: Leave the brad heads protruding above the top of the jig table so you can remove them once you've permanently attached the table to the guide strips.

Attach the guide strips permanently to the plywood table with some short, flathead wood screws, driven up from the bottom. Use about three screws per strip and be sure to countersink their heads below the guide strip surface. Be sure to keep all screws away from the location of the groove you'll be cutting in Step 4, below.

4: Use your dado blade to cut a 3/4" wide by 3/8" deep groove in the plywood tabletop to accept a Featherboard.

5: Tilt your saw table to 45-degrees. Use a carbide-tipped combination blade set to a depth of 1-5/8" to saw an angled through kerf 11" into the plywood table surface.

6: Using an accurate triangle or square, draw a line perpendicular to the kerf you cut in step 5. This line will be used to position the jig fence accurately.

7: Cut parts (C,D,E,F) to size and glue them together according to the drawings. This assembly will form the slotted fence. Use screws and glue to attach the fence to the plywood table, flush with the line you drew in step 6 above. As an alternative, you could make a solid fence and cut a 5/16" wide travel slot in it with a router bit.

8: Cut out the guard (G) and attach it to the plywood table, behind the fence, and in line with the saw kerf. This piece will act as the saw guard.

9: Make the stop block (H) and mount it through the slot in the fence.

10: Use a Scroll Saw to cut out the handle (J). Use glue and screws to attach the handle over the right hand guide strip on the plywood table. Place the jig on the table and make a kerf cut at 45-degrees into the fence. Do not cut through the guard (G). After cutting, slide the jig back, away from the saw.

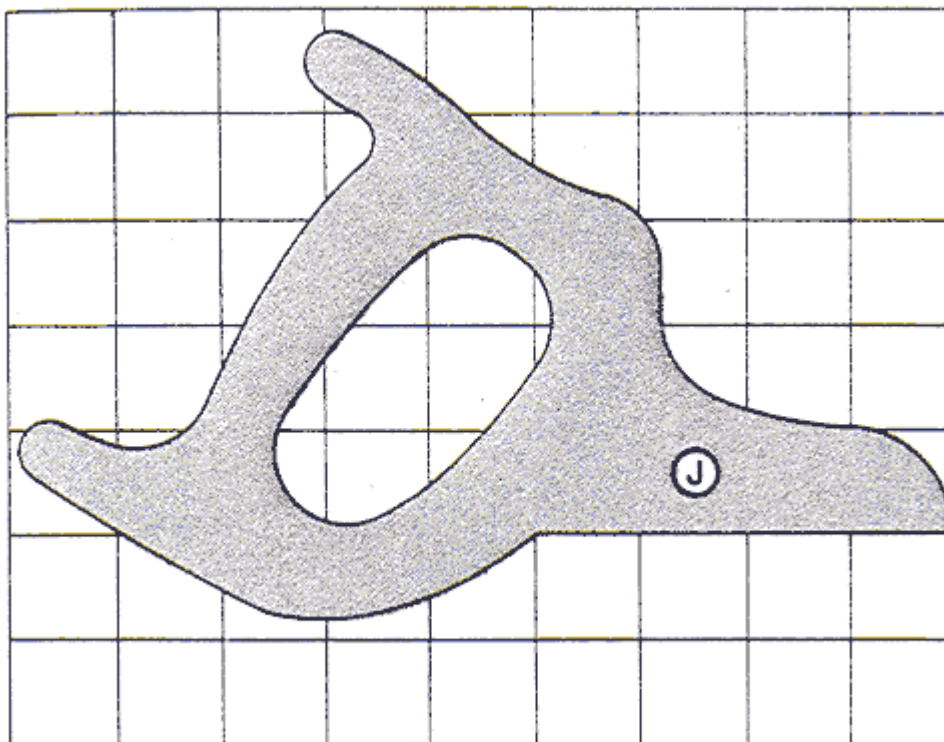

HANDLE LAYOUT

1 SQUARE = 1"

Using the Jig to make boxes

Once you've made the Jig, creating a variety of different sized and shaped boxes is fast and simple. Here's how to make a box that's 3" high x 5" deep x 8" long. We used 1/2" thick stock for the box sides.

Step 1: Prepare the stock for production. Start by using the table saw to rip a series of 2-7/8" wide pieces of stock for the box sides. Then use your Jointer to bring them to a final width of 2-3/4".

Next, use your Bandsaw with a 5/8" Resawing Blade to thin your stock down to slightly thicker than 1/2". Use your Jointer or a Thickness Planer to bring your stock to a final thickness of 1/2". Crosscut your prepared stock into two 8-3/8" lengths and two 5-3/8" lengths.

Now, prepare two pieces of stock 3/16" thick x 5-1/8" x 8-1/8" for the top and bottom.

Step 2: Tilt the saw table to 45-degrees and set a hollow-ground or carbide-tipped blade height to 1-5/8" (without the Jig in place). Make test cuts on scrap stock to check the accuracy of your cut.

Step 3: Set the Jig on your saw table and place one of the 8-3/8" pieces in it. Adjust your stock against the fence so that the end to be cut protrudes 3/16" past the kerf cut into the fence (See Fig. 1). Slide the stop block up against the other end of your stock and tighten the bolt. Adjust your featherboard against the edge of the stock so the stock will be held firmly against the fence. Bevel one end of each 8-3/8" board.

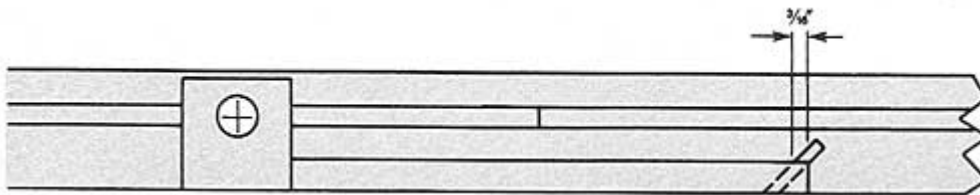

Step 4: Measure 8" from the mitered end and mark the stock on the uncut end. Set this piece in the jig, align the mark with the kerf and re-adjust the stop block (See Fig. 2). Cut all remaining ends of the boards.

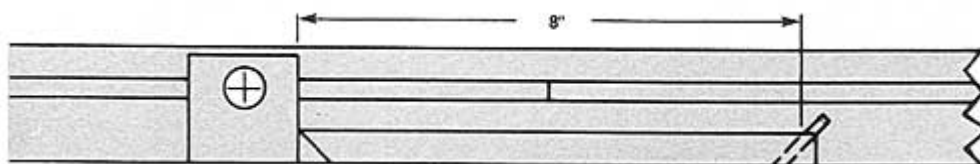



Step 5 Repeat steps 3 and 4 for the 5" sides of the box.

Step 6 (Optional) Reinforce the mitered corners with splines made from contrasting wood. For tips on performing this operation, refer to your copy of the "Power Tool Woodworking For Everyone" textbook that came with your MARK V.

If you want dividers in your box(es), remove the jig from your saw table and cut 1/8" or 1/4" wide dados on the inside faces of your stock to accommodate these 1/8" or 1/4" thick dividers...prior to assembly.

Step 7 Use woodworker's glue to assemble the sides of your box(es). To clamp, use large rubber bands (See Fig. 3) or pieces of an old rubber inner-tube. Once the glue has dried, carefully sand the top and bottom edges flat using your Belt Sander. Be careful not to remove more stock than necessary.

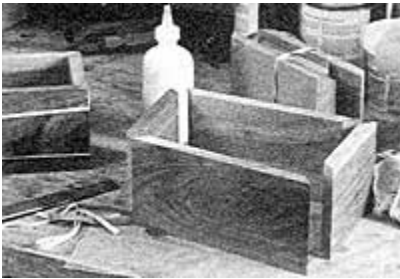

Fig. 3. Use rubber bands or pieces of inner tubes and woodworker's glue to assemble the boxes.

Position the tops and bottoms so they overhang the edges of the box by about 1/16" all the way around. Apply glue and weight them with bricks or similar heavy objects (See Fig. 4) until they dry thoroughly.



Fig. 4. Apply the top and bottom and place weights on top.

Step 8: Once the glue has dried, use your Belt Sander to sand the box(es) so the tops & bottoms are flush with the sides. (See Fig. 5&6)

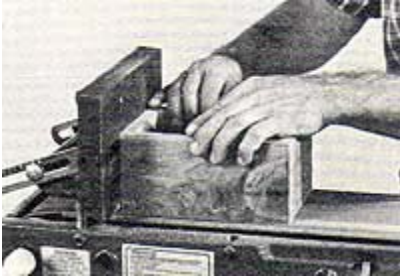

Fig. 5. After the glue has dried, sand the boxes. When using the belt sander, keep the box moving from side-to-side.



Fig. 6. Sand the sides flush after the glue has thoroughly dried.

Next, use your Bandsaw with a 5/8" resawing blade to cut the lid from the box. If you like, you can tilt your Bandsaw table 5 to 10-degrees when doing this for a different look (See Fig. 7). Be sure to follow-up by belt sanding the rims carefully to be sure they're flat and true.

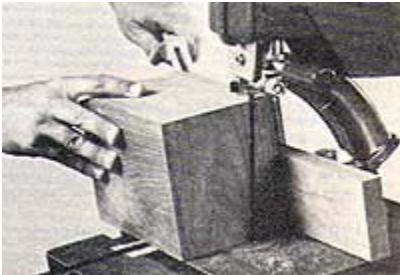

Fig. 7. Use the bandsaw to cut the lid from the box. Use a belt sander and carefully remove the saw marks from the top and bottom rims.

Step 9: Mount the hinges, attach the lid, then apply the finish of your choice.

As you can see, the potential for boxes is limitless. Using various woods, altering their sizes, adding partitions, inlaying decorations or adding decorative hardware are only a few creative ways to mass-produce stunning gift boxes for friends and relatives.

LIST OF MATERIALS -
(finished dimensions in inches)

A	Plywood Table	3/4 x 13 x 22
B	Guide strips (2)	1/4 thick x (width of miter gauge slot) x 14
C	Fence (top)*	3/4 x 1/2 x 22
D	Fence (spacer)*	3/4 x 5/16 x 1
E	Fence (spacer)*	3/4 x 5/16 x 8
F	Fence (bottom)*	3/4 x 1 x 22
G	Guard	1-1/4 x 1-3/4 x 4
H	Stop block	3/4 x 1-3/4 x 1-3/4
J	Handle	3/4 x 5-1/2 x 9
Optional: #12 x 1-1/4" roundhead wood screws (2)		

Miscellaneous

1/4" Knurled knob

1/4" x 2" Carriage bolt

*For making a four-piece Fence, as shown in the drawing. As explained in step 7, you could alternatively choose to make a one-piece fence with a routed 5/16" travel slot.

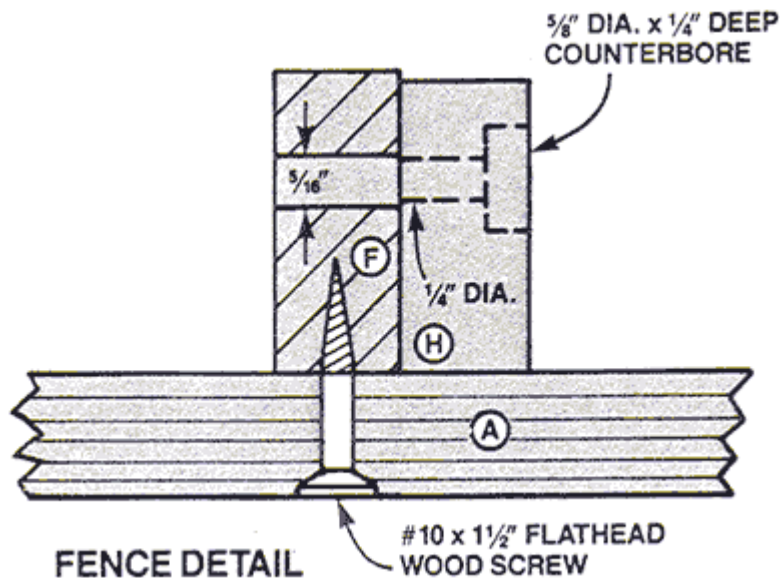

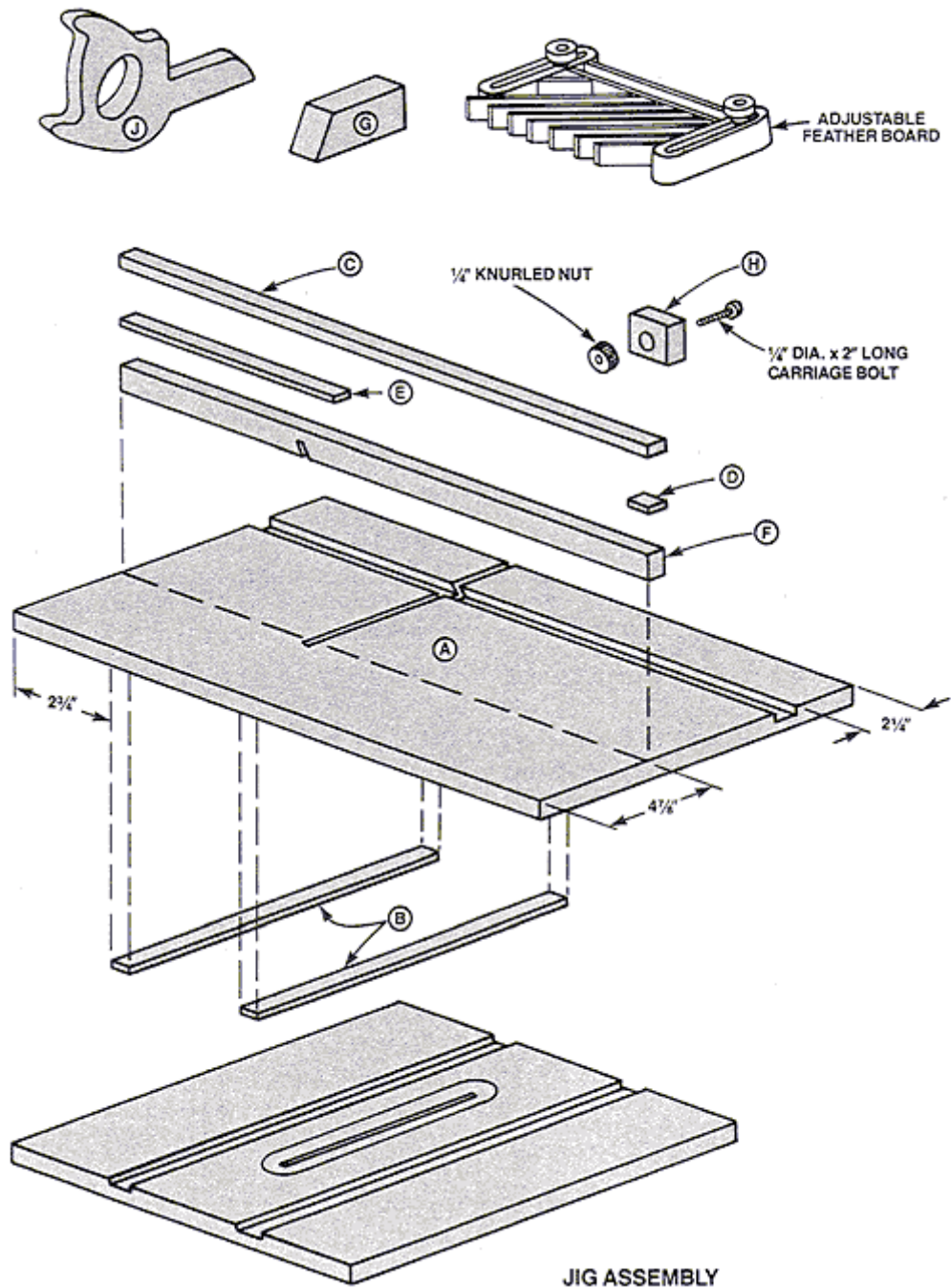

THE SHELTERED SWING



"My wife always wanted a porch swing...", wrote Bob Thompson, winner of Shoppersmith's (1982) Woodworking In The Great Outdoors contest. "...but we didn't have a porch to hang the thing from." So, Bob designed and built his own mini-porch to shelter the swing. And even after more than 20 years have passed, we think that Bob's design is as timeless today as it was way back then - and we'll bet you'll agree.

The Swing

Bob made the swing-portion of his project out of oak...but you could just as easily make it from almost any wood. Other great choices (for their weather-resistance) would include redwood, Western red cedar, cypress or first-rate pressure-treated lumber. The sizes can also be easily modified. For example, you might prefer a slightly longer swing - or a larger shelter for more protection from rain or ultraviolet rays. The choice is yours.

Start by cutting all of your swing components to size, according to the Bill of Materials. Use a Bandsaw to cut the contours on the seat supports (B), the arm rests (D) and the angled ends of the back supports (F). Once cut, use your Drum Sander to sand these cuts smooth.

Next, assemble the rectangular base of the swing, which is comprised of the five curved-top seat supports (B) and the front and rear rails (C). Attach seven of the slats (A) to the curved tops of the seat supports with 3d galvanized nails and a good quality waterproof glue.

Start by evenly spacing your five seat supports (B) on a benchtop or the floor. When you're sure they're aligned properly, attach the front and rear



rails (C) to each end of the seat supports (B) using two 3d galvanized nails and waterproof glue. To help prevent splitting, drill 1/32" pilot holes for the nails through the front and rear rails only. Do not drill pilot holes into the end grain of the seat supports. Once you're certain the assembled seat frame is square, set aside to dry thoroughly before proceeding.

Use 1/4" spacers to help you evenly space seven of the slats (A) across the tops of the seat supports and attach them with waterproof glue and 3d galvanized nails. As with the seat frame, it's important to drill 1/32" pilot holes for the nails. These holes should be drilled through the slat AND into the seat supports below.

IMPORTANT: Use an accurate 90-degree square to ensure the precise alignment of each slat prior to drilling your pilot holes... and 1/4" spacers between each slat to aid with proper positioning. Move from the back edge of the seat supports (B) to their front edges, repeating this procedure as you install all seven slats.

Next, the arm rest supports (E) are secured to the front and rear rails (C) with carriage bolts, washers and nuts. NOTE: These four bolts with oversized washers will also act as the anchors for the swing chain ends.

Drill holes in the arm rests (D) to allow the chain to pass through. You may have to adjust the hole sizes to accommodate the chain you plan to use. Attach the arm rests (D) to the tops of the arm rest supports (E) with 6d galvanized nails and waterproof glue.

Assemble the rectangular back of the swing using the remaining six slats (A) and the five back supports (F). Follow the same procedure as outlined for the seat, except use 2" spacers when positioning the back slats. Start by attaching the first slat to the top edges of the back supports (F) with 3d galvanized nails and waterproof glue.

This first horizontally-positioned slat will act as a "cap", covering the top ends of the back supports (A) and overlapping the top edge of the first vertically-positioned back slat immediately below it. As with the seat assembly, do not drill pilot holes into the end grain of the back supports.

Attach the assembled back to the rear seat rail (C) with 6d galvanized nails through the bottoms of the back supports (F). You must strengthen this assembly with carriage bolts through each of the rear arm rests (D) where they adjoin the back supports (F).

Finish sand the entire swing assembly and apply the stain or clear finish of your choice.



The Shelter

The stanchion (standing frame) for the shelter structure is assembled from 4" x 6" pressure-treated posts and a 4" x 6" cross-beam.

The rectangular roof frame is made from pressure-treated 2" x 4"s, bolted to the stanchion and covered with exterior grade plywood, roofing felt and shingles. A slotted 2" x 4" extends above the ridge board so the roof rafters will clear the cross-beam. The gable ends are covered in strips of 3" western red cedar...and the fascia boards are 1" x 6" cedar with 1" x 2" cedar furring strips to support a metal drip edge.

The roof assembly is then attached to the stanchion with 3/8" x 5" lag screws...then reinforced with four decorative scallop brackets.

LIST OF MATERIALS -

(finished dimensions in inches)

The Swing

A	Slats (13)	1/4 x 1-3/4 x 55-1/2
B	Seat Supports (5)	3/4 x 2-1/4 x 14-1/2
C	Front & Rear Rails (2)	3/4 x 2-1/4 x 60
D	Arm Rests (2)	3/4 x 2-1/4 x 17-3/4
E	Arm Rest Supports (4)	3/4 x 2 x 8-3/4
F	Back Supports (5)	3/4 x 1-1/2 x 22

The Shelter Assembly

(See dimensions and materials requirements on Shelter Assembly drawing and alter as required to suit your needs.)

The Hardware

Swing

1/4" x 2-1/2" carriage bolts w/nuts & washers	(6)
1-1/4" O.D. fender washers	(4)
Chain	(18 ft)
6d galvanized nails	(1 lb)
3d galvanized nails	(1/2 lb)



Shelter

3/8" x 6" eye bolts	(2)
3/8" x 5" lag screws	(8)
3/8" x 8" lag screws	(2)
Metal drip edge	
Miscellaneous nails	

SWING LAYOUT 1

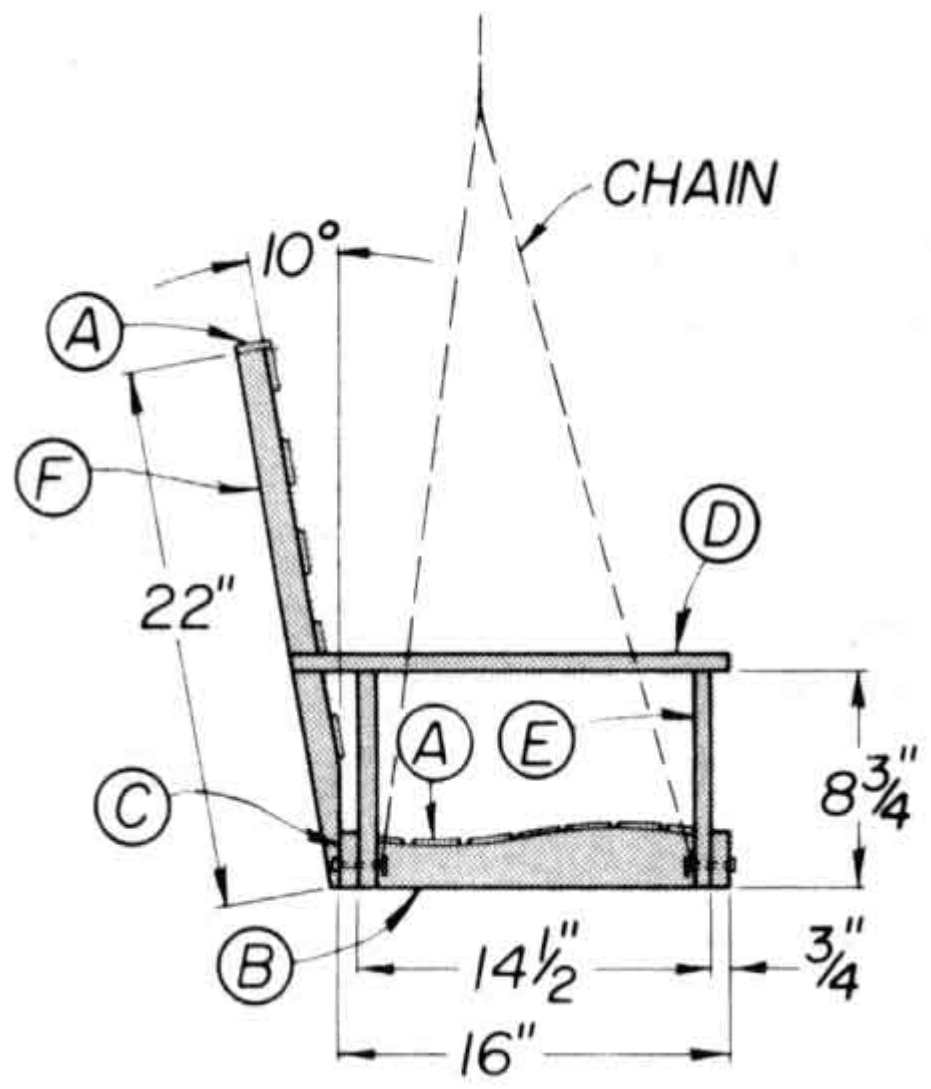

SWING LAYOUT 2

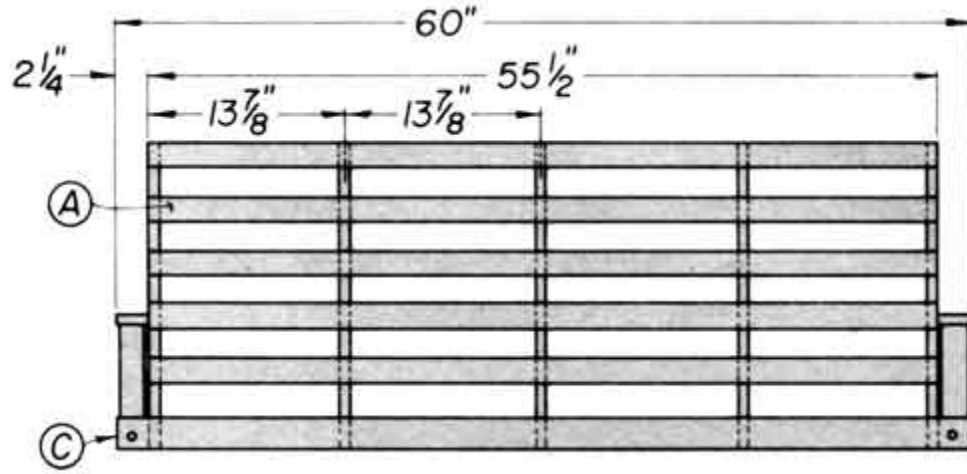

SUPPORTS

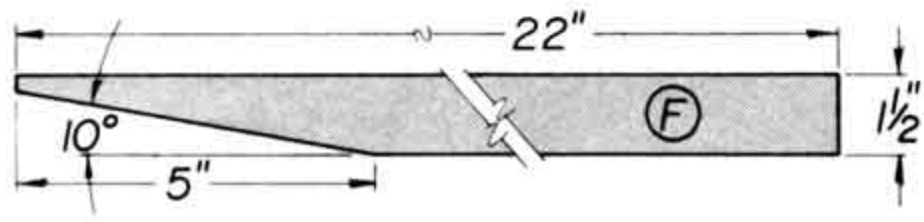
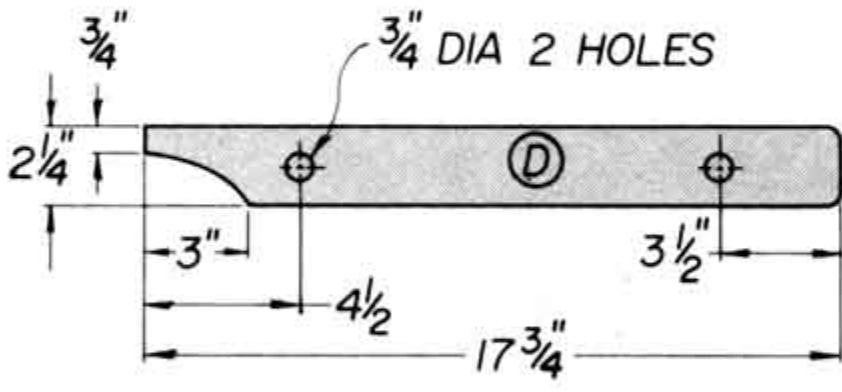
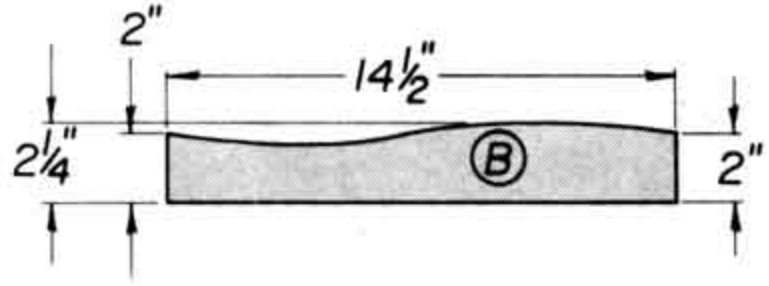

SCALLOP LAYOUT

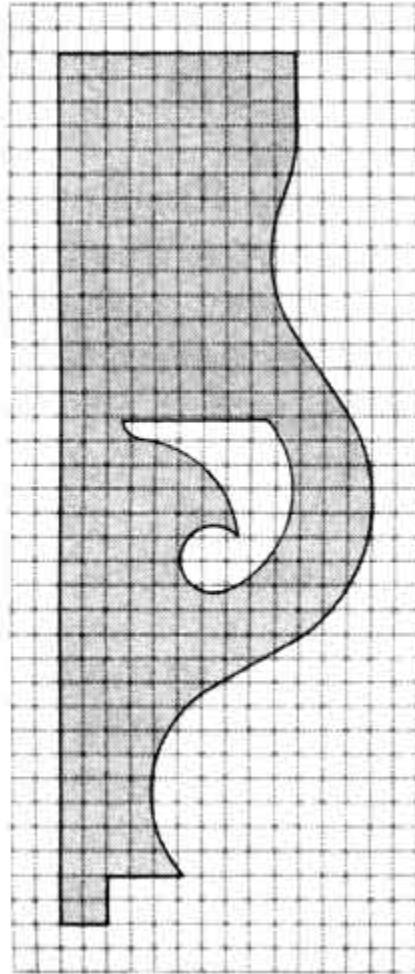

SHELTER ASSEMBLY

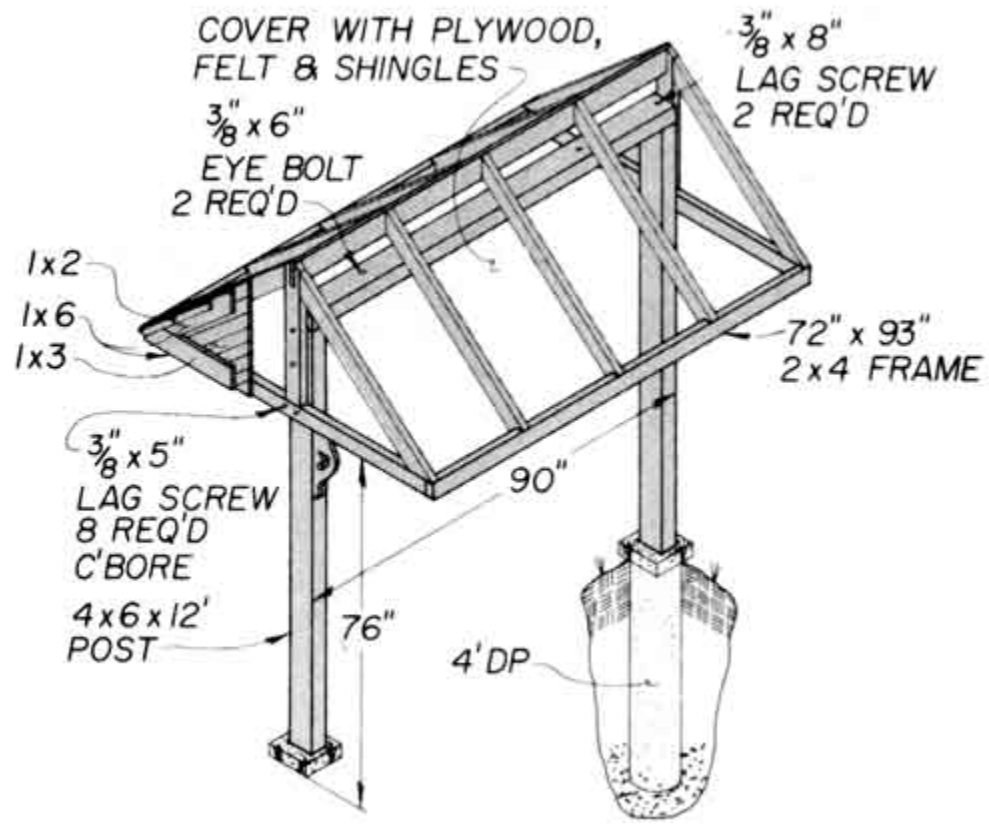

RAFTER LAYOUT

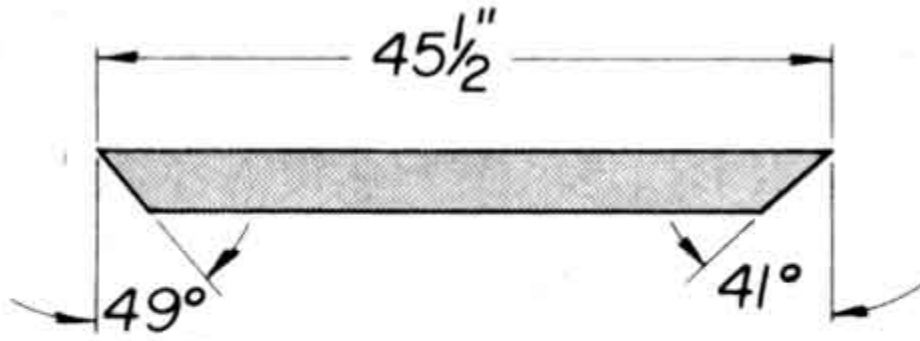

END RAFTER LAYOUT

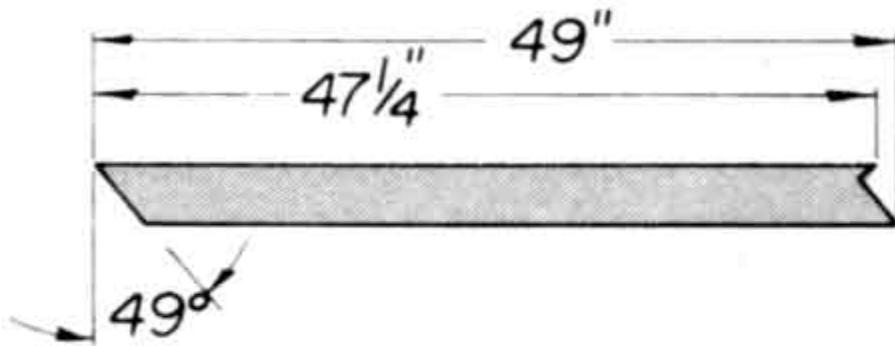

MIDDLE RAFTER LAYOUT

MEDICINE CABINET-2



Some projects look complicated, but really aren't. This cabinet is one of those projects. In fact, it's so simple that it's probably just as easy to make several at a time and give them as gifts to lucky family members and friends. In fact, if you have a Bandsaw and one of our new 6" high Drum Sanders, you can stack and pad saw, then drum sand enough sides (A) for four Cabinets at once - and enough top backs (E) for six.

Just nine simple steps and a 2-day weekend are all you'll need to complete one of these handsome Cabinets. Add about one more day and you could probably have five or six of them ready to bring some great smiles to a lot of faces. Here goes...

1. Cut the sides (A), top & bottom (B) and towel rod (C) to size, according to the Bill of Materials.
2. Use your Dado Set to cut the dadoes in the sides (A) for the top and bottom (B) - and for the stop rabbets in the sides (A) for the plywood back (J).
3. Use your Band saw or Scroll Saw to cut the contours on the sides (A) and top back (E). Smooth the curved surfaces of all cuts using a Drum Sander.
4. Drill the holes for the towel rod (C). Dry-assemble the sides, top, bottom and towel rod to check for squareness. When satisfied, assemble with glue and finishing nails. Install the back (J) with brads and no glue.
5. Cut the face frame stiles (F) to fit precisely between the top and bottom (B). Add a saw kerf or two...or use your Molder accent the front surfaces of the stiles. Glue and nail these into place.



6. Cut the shelves (D) and top back (E) to size, using the assembled frame as your guide. Shape the top back, then glue and nail these three pieces into position.

7. Prepare the door frame stock by first ripping stock to width. Then, use your table saw with a dado blade or a router set-up with a rabbeting bit to cut a 3/8" x 3/8" rabbet in the back side for the mirror or glass. Set your miter gauge to 45-degrees and cut the stiles (G) and rails (H) to size. Glue and nail the door frame together.

8. Mortise the door frame and the carcass for the hinges using a chisel. Drill a hole for the knob. Use a nailset to countersink all nails, then fill the holes with wood putty.

9. Apply the finish of your choice, then install the mirror or glass. If you're using a 1/8" thick, single-strength glass mirror, be sure to strengthen it with a 1/4" plywood back-up.

LIST OF MATERIALS -
(finished dimensions in inches)

A	Sides (2)	3/4 x 4 x 27
B	Top and bottom	3/4 x 4 x 15
C	Towel Rod	3/4 dia. x 15
D	Shelves (2)	3/4 x 3 x 14-1/2
E	Top Back	3/4 x 4 x 14-1/2
F	Face frame stiles (2)	3/4 x 1-1/2 x 17-1/2
G	Door Stiles (2)	3/4 x 1-1/2 x 17-1/2
H	Door Rails (2)	3/4 x 1-1/2 x 11-1/2
J	Back	1/4 x 15 x 18

Miscellaneous:

1/4" x 9-1/8" x 15-1/8" mirror or glass

1-1/2" x 1" butt hinges (2)

6d finishing nails

Knob

ASSEMBLY

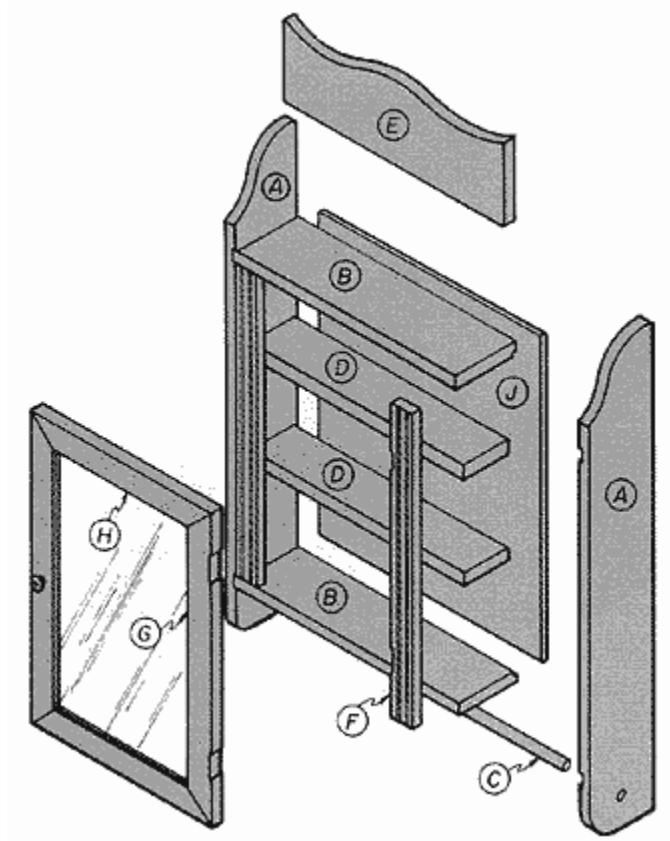

PLANS

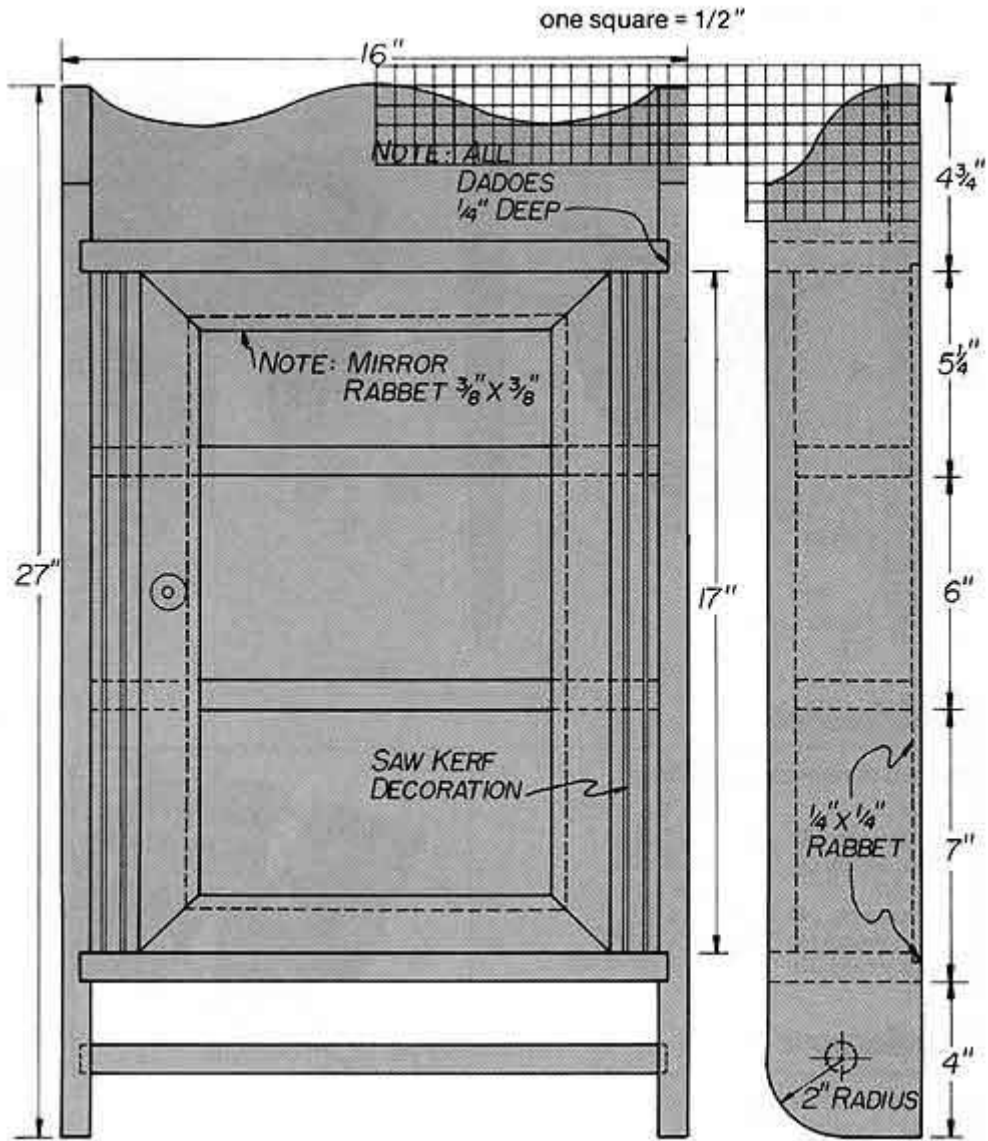

PUZZLE POWER



Cheryl Barnett, a craftswoman from Beavercreek, Ohio designs and makes delightful jigsaw puzzles as gifts...and to donate to church bazaars. Cheryl says that for strength and durability, she uses 1/4" or 3/8" thick high-quality, solid-core plywood and assorted hardwoods for her puzzles. **NOTE:** When making large quantities of these puzzles for resale, we suggest that you stack a number of work pieces and pad saw multiples simultaneously. Use double-stick tape to hold the pieces together temporarily for cutting. Make your stacks up to 2" thick if you'll be cutting them out with your Scroll Saw ... up to 6" thick if you'll be using your Band saw . Once cut, simply separate the parts.

1. Use a Belt Sander or hand-held orbital sander to sand both surfaces of your stock smooth.
2. Make a full-scale pattern from the plans by photocopying or re-drawing them, then attach a plan to the top of each "stack" with rubber cement or re-positionable adhesive from an office supply store.
3. Use your Scroll Saw to cut out the designs on the bold lines (the dotted lines are for detail painting). The Scroll Saw will make much smoother cuts than the Bandsaw...without having to sand the cut lines.
4. If necessary, sand the cut lines of your puzzles, being careful not to distort the interlocking patterns.
5. Starting with the large areas, paint the designs with non-toxic paints or food coloring.



***TIP:** It's best to trace the detail painting lines after you've painted the large areas. A fine-point permanent marker can be used for drawing the details.*

6. Coat the finished puzzles with a clear polyurethane varnish.
Suggested retail price: \$15 to \$20 per set of six

Plans

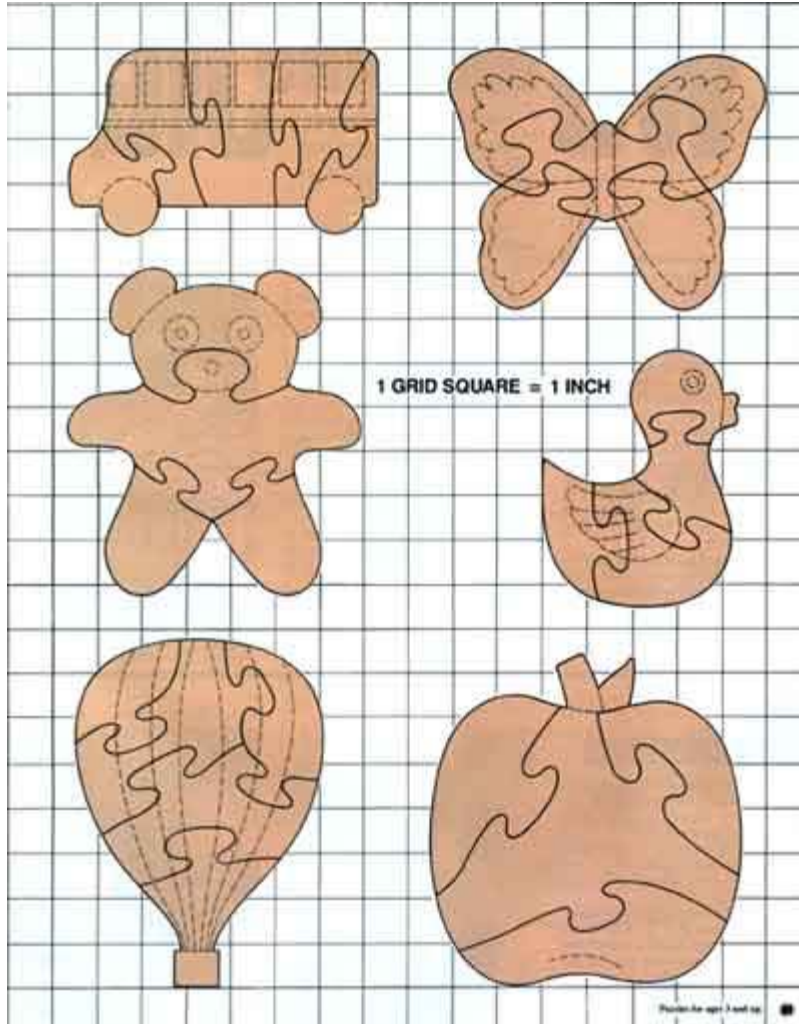

ENGLISH FLIP-TOP CHAIR-TABLE



The origin of this chair-table design dates back to 16th century England. It's an excellent example of multipurpose furniture, offering a draft-free place to sit near the fireside - a round-top table when the chair back is lowered - and a generous 13" x 23" x 7" storage drawer.

It's an idea that remained popular among furniture-makers on both sides of the Atlantic until well into the 19th century...an enduring concept that's not exactly what you'd call "a flash-in-the-pan".

Today, there are several companies around the World making "convertible" furniture. Chairs that become beds. Cocktail tables that convert into dining tables. Chests of drawers that "hide" plasma TV's. Where did it all start? Chances are...a chair-table like this one marked the beginnings of multi-purpose furniture nearly four centuries ago.

1: Cut all parts to size, following the List of Materials. Start by studying the list and finding all of the parts that are to be cut to equal widths and lengths. Rip-cut your parts first, then crosscut them to length. By grouping all same-sized parts together during this step, you'll save lots of time that would otherwise be required to make duplicate set-ups. NOTE: See Step 2 for special instructions on cutting out the top.



2: Make the Top (J), by first drawing a 42" diameter circle on the shop floor. Arrange the boards you're planning to use for this piece on top of your drawn circle to maximize the use of your available stock and determine the ideal grain patterns.

Cut all of your pieces to approximate length with an ordinary combination saw blade...then use a Hollow-Ground Blade to "shave" them super-smooth and bring them to their final lengths. Run all ripped edges over the Jointer in preparation for glue-up.

Glue all of the Top boards together. Use dowels or biscuits if you like, for reinforcement. Shopsmith's 48" Double Bar Clamps will help you hold everything flat and true while the glue dries.

Once everything has dried thoroughly, mark the center of your glue-up, draw a 42" diameter circle and cut the top out using your hand-held sabre saw, a Bandsaw or a Scroll Saw to make your circular cut. Stay slightly outside your cutting line so you can go back and sand everything smooth to the line with your Disc Sander.

ALTERNATIVE: As an option, you could make the top from 3/4" solid core veneered plywood and cover the edges with veneer edge banding.

3: Drill the dowel holes, in parts (A,B,C,D,G) using the MARK V Horizontal Boring mode of operation. Start with the ends of the sides (C), end (D) and rails (G). Next, locate the dowel positions on the legs (A) and drill these holes.

Dry assemble the sides, ends, rails and legs. Locate the dowel holes in the tops of the legs for the arms (B). Locate the matching dowel holes for the arms, then disassemble the chair. Drill the remaining dowel holes.

Round the back ends of the arms (B). Locate and drill 5/8" holes for the pivot pins (R) in the arms (B) and drill the hole for the locking pin (S) in the front of one arm. Mark the locations of the pin holes in the battens (K) and drill. NOTE: One batten has two holes -- one for the pivot pin (R) and one for the locking pin (S). Set the battens aside.

4: Assemble the chair. First, glue and clamp each of the legs (A) to the sides (C). After these have set up, glue these assemblies to the end (D) and rails (G). Check for squareness as you go. Glue the arms (B) into place.

Attach the drawer runners (F) to the drawer guides (E) with #8 x 1-1/4" flathead wood screws. Attach these assemblies to the inside of the chair assembly.



Cut out the notches for the legs in the seat (H) and attach the seat with #8 x 1-1/4" flathead wood screws. Bore 1/4" deep x 3/8" diameter counterbores for the screw heads use dowel plugs to fill the holes.

5: Make the drawer. First, check the size of the drawer opening on the assembled seat. Cut the drawer front (L) and back (N) to allow for 1/8" total clearance on the width. Cut the front, back and sides of the drawer to allow for 1/16" clearance on the height.

Cut the 1/4" groove for the bottom with your dado blade or your MARK V Routing Attachment.

Cut the 3/4" wide x 3/8" deep dado in the sides, to accept the back. Then form the locking drawer joint (see Drawer Joint Detail). Assemble the drawer by gluing and clamping the front, sides and back together. Check for squareness, slide in the bottom and secure it with a few 2d wire nails or brads. Do NOT use glue on the bottom.

6: Contour and drill the battens (K) according to the drawings (see Batten Layout). Use your bandsaw or a Taper Guide on your Table Saw to cut the angles. Drill 3/8" diameter screw pockets and pilot holes for the #10 x 1-1/2" roundhead wood screws. Use an oversized pilot hole to allow for expansion and contraction of the top.

Center the chair assembly upside-down on the bottom of the tabletop to locate the position of the battens. The battens must run at right angles to the grain of the top boards to provide strength and prevent warping. Mount the battens to the top with the screws, then cap the screw pockets with dowel buttons.

7: Turn the pins (R, S) from the 1-1/2" square stock. Turn all three pins at once (See Fig. 1). Note that the locking pin is shorter since it is not a through pin. Next, turn the drawer knob (Q). Use your Screw Center to mount the stock on your MARK V Lathe.

8: Finishing touches. Perform all finish sanding and apply the finish of your choice to all surfaces. Cut out felt washers to go between the arms and the battens to protect the wood.



LIST OF MATERIALS –

(finished dimensions in inches)

A	Legs (4)	1-3/4 x 1-3/4 x 26-1/2
B	Arms (2)	1-3/4 x 1-3/4 x 19-1/2
C	Sides(2)	3/4 x 10-1/2 x 21-1/2
D	End	3/4 x 1-1/2 x 14
E	Drawer Guide s (2)	3/4 x 1-3/4 x 21-1/2
F	Drawer Runners (2)	3/4 x 1-3/4 x 23-1/2
G	Rails (2)	3/4 x 1-3/4 x 14
H	Seat	3/4 x 17-1/2 x 25
J	Top	3/4 x 42 diameter
K	Battens (2)	3/4 x 2-1/2 x 32
L	Drawer Front	3/4 x 7 x 14
M	Drawer Sides (2)	3/4 x 7 x 24
N	Drawer Back	3/4 x 6-1/2 x 13-1/4
P	Drawer Bottom	1/4 x 13-1/4 x 23-1/8
Q	Drawer Knob	2 diameter x 1
R	Pivot Pins (2)	1-1/2 x 1-1/2 x 4
S	Locking Pin	1-1/2 x 1-1/2 x 3

The Shelter Assembly

3/8" dia. x 2" dowel pins

3/8" dowel buttons (12)

5/8" I.D. x 1-1/2" O.D. felt washers (2)

#12 x 1-1/2" flathead wood screw (for knob)

#10 x 1-1/2" roundhead wood screws

#8 x 1-1/4" flathead wood screws

2d wire nails

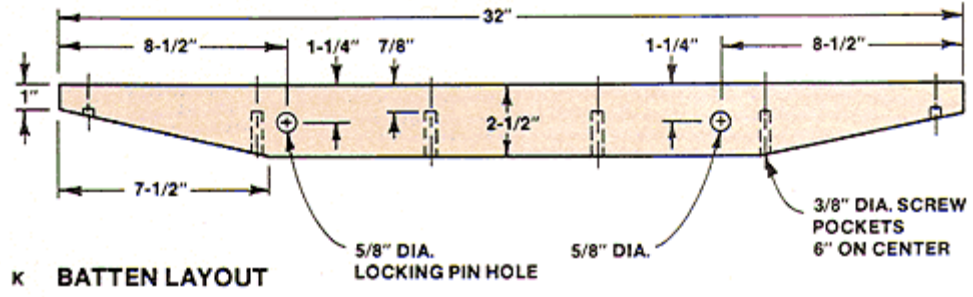

Side View

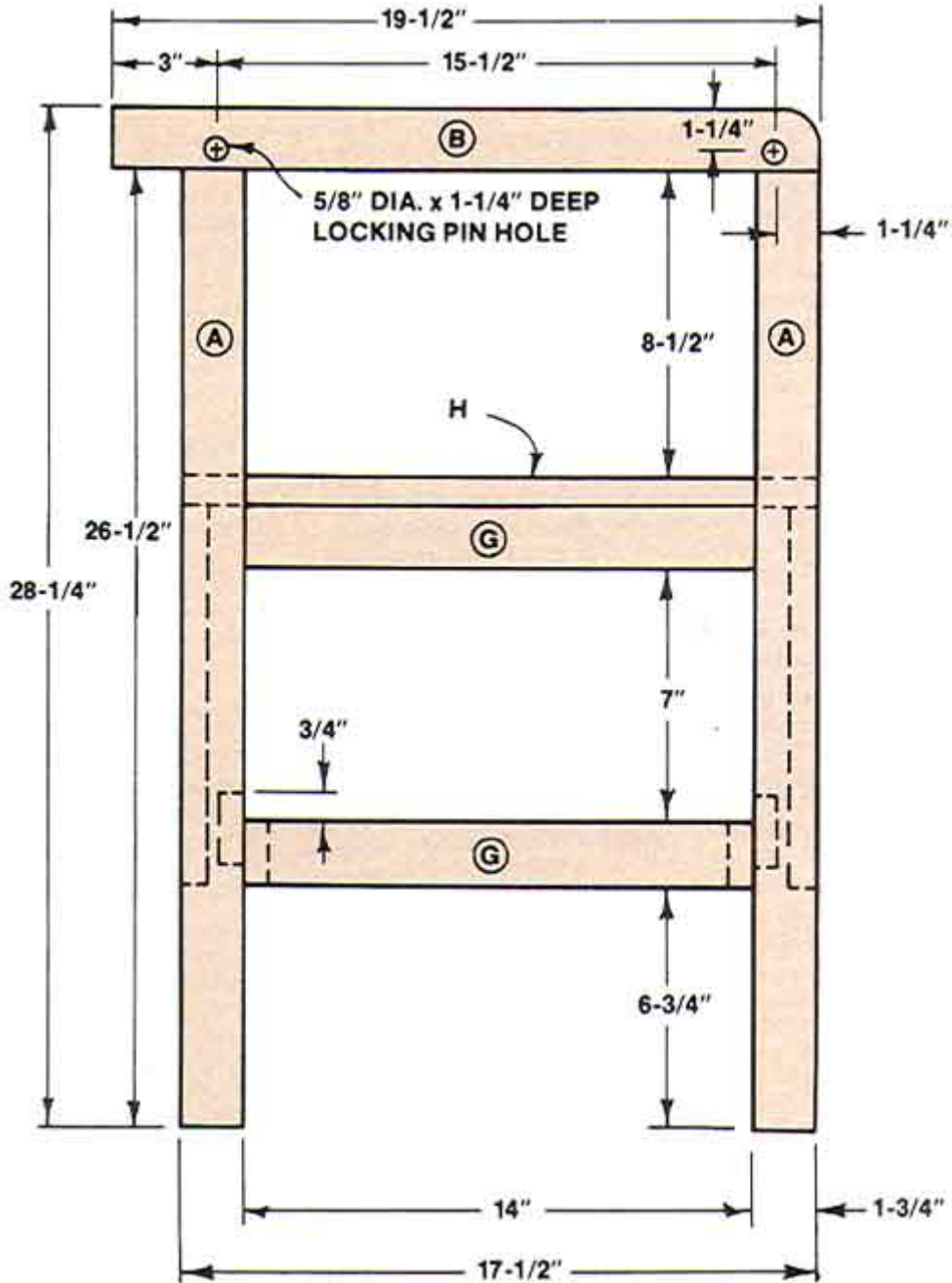

Drawer Knob

1 GRID SQUARE = 1/4"

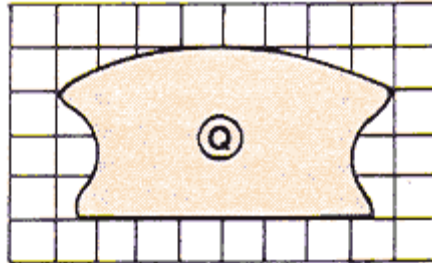

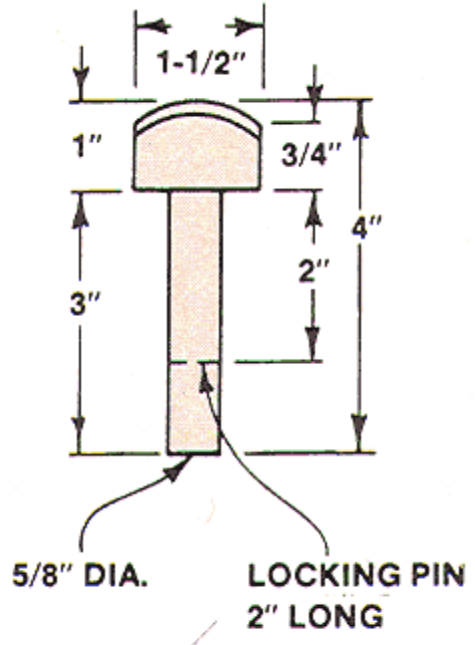

PIN LAYOUT

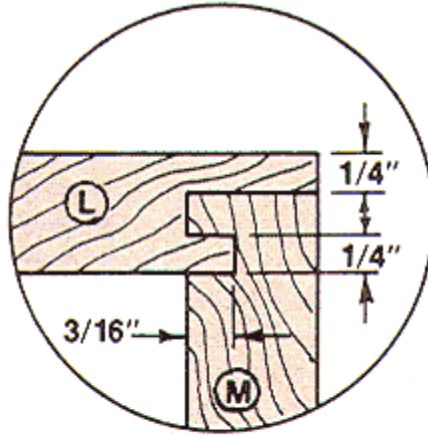

DRAWER JOINT DETAIL

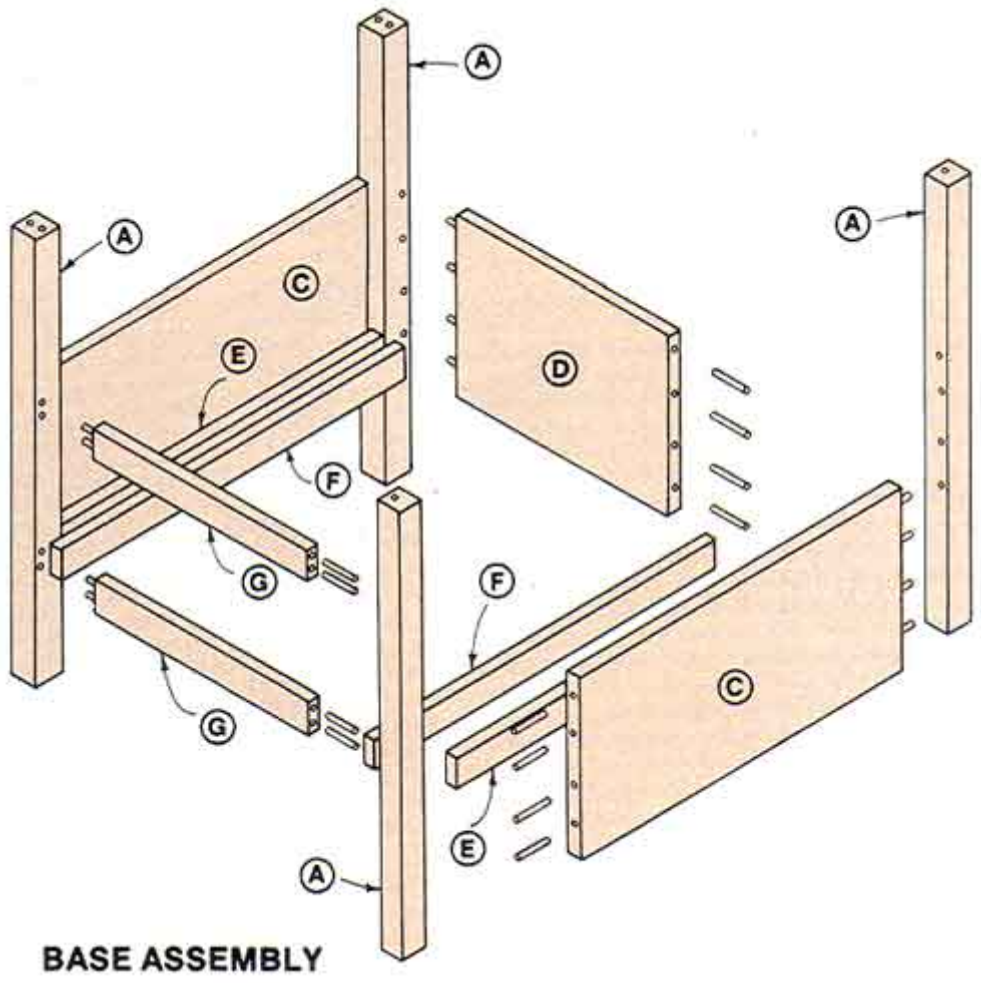

BASE ASSEMBLY

DRAWER ASSEMBLY

3/4" WIDE x 3/8" DEEP DADO
1/2" FROM END

1/4" WIDE x 3/8" DEEP GROOVE
1/4" FROM EDGE

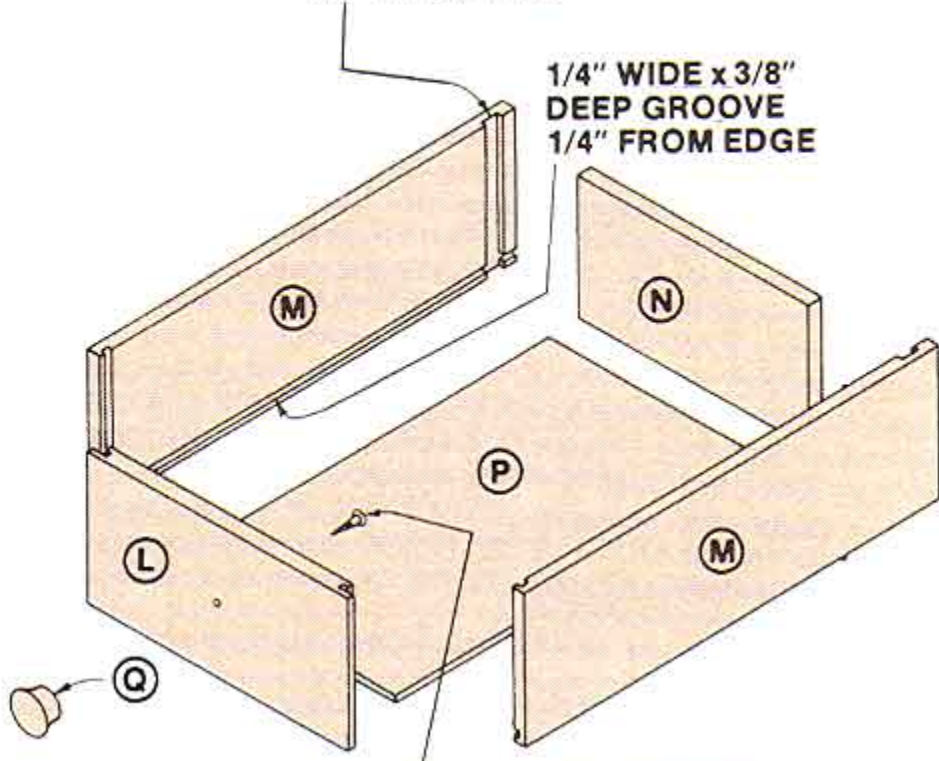

#12 x 1-1/2" FLATHEAD
WOOD SCREW

Final Assembly

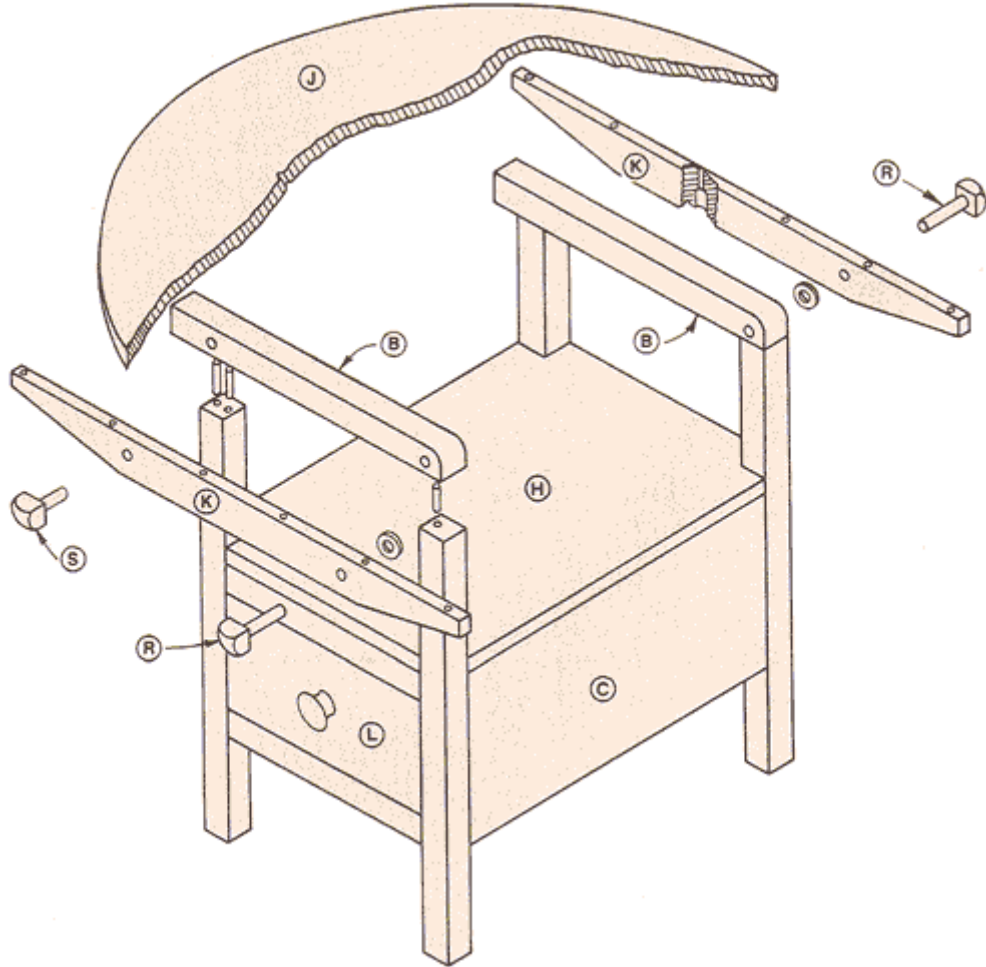



OVAL MAGAZINE RACK



These attractive magazine racks are so simple to make that as long as you're going to make one of them, you may as well make four or five for your house...and a few more to give as gifts.

- 1: Prepare a 3/4" x 9-1/2" x 22" piece of stock for each rack. As you can probably see, the bottom of each rack is made from the "scrap" piece that comes from the top cut-out.
- 2: Use your Scroll Saw to cut the Bottom (B) from the Top (A).
- 3: Use a Drum Sander to smooth the inside edges of the Top (A) - and your Disc Sander to smooth the outside edges of the Bottom (B).
- 4: Use your Shaper set-up with a Quarter-Round Cutter - or your Router set-up with a 3/8" Round-Over Bit to round the inside edge of the Top (A).
- 5: Use your Bandsaw or Scroll Saw to cut the outside contour of the Top...then sand and shape this edge. Shape the outside edge of the bottom .
- 6: Mark all dowel hole positions on the Top and Bottom pieces. Tilt your MARK V table to 10 degrees and use a 3/8" diameter bit to bore 1/4" deep holes at your market locations for the dowels.
- 7: Cut all dowels to length and lightly sand the rods.
- 8: Assemble the rack by first gluing the dowels into the Top...then gluing them into the Bottom. Use a wood glue with an extended "open time" to avoid having to rush through the assembly process before your glue sets-up.

9: Finish sand the project and apply the finish of your choice.

LIST OF MATERIALS -
(finished dimensions in inches)

A	Top	3/4 x 9-1/2 x 22
B	Bottom	3/4 x 6-1/2 x 19
C	Dowels (12)	Four 3/8 dia. x 3-foot dowel rods

Assembly

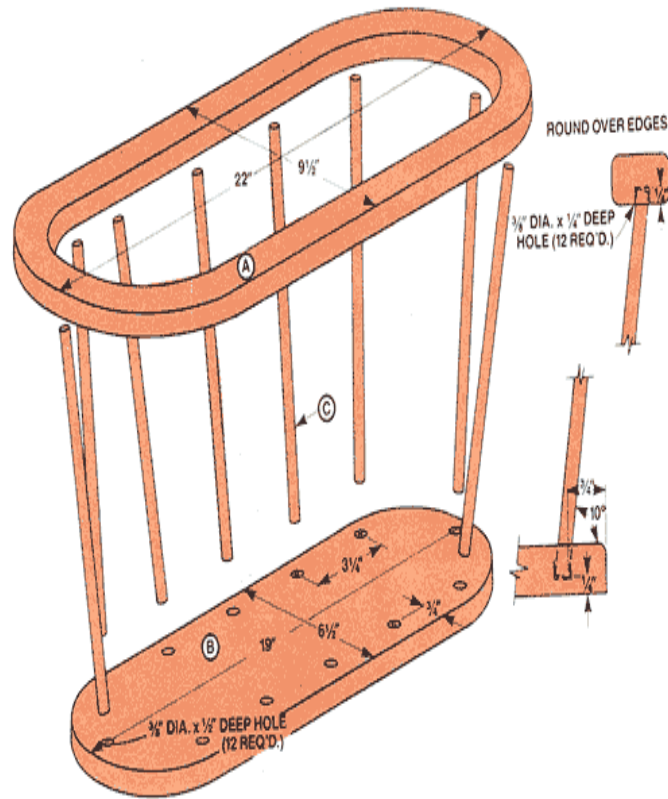

BREAD-SHAPED CUTTING AND CHEESE BOARDS



Talk about fast and easy ! These simple Bread-Shaped Boards are about as fast and easy as any project comes, these days.

Make them out of a single wood...or glue-up contrasting colored strips (maple & walnut, etc.) like many of the cutting boards you see today.

Change the shape to an Italian loaf (or slice cross-section), or that of a biscuit or muffin. Use your imagination.

1: Glue-up your choice of woods for the 1-1/2" thick Cutting Boards and the 3/4" thick Cheese Boards. Since they will be exposed to food and will therefore need to be washed, it's best to use a waterproof (or at least water resistant) glue for this.

2: Once the glue has dried completely, scrape off any big clumps of surface squeeze-out, then run your glued-up stock through a Thickness Planer , a thickness sander or over a stationary Belt Sander to smooth the surfaces thoroughly.

3: Make stiff cardboard templates of the designs you plan to use, then transfer them to your workpieces.

4: Use your Scroll Saw to cut out your edge shapes.

5: Depending on your external shape, use any combination of your Disc Sander, Drum Sander or Strip Sander to smooth the outer edges you've just sawn.

6: If you're making these Bread-Shaped Boards, apply a dark stain to the outer edges for the "crust"...then apply a non-toxic finish such as Salad Bowl Finish as a preservative.

CANDLE STAND



Simple and functional – are the hallmarks of Shaker furniture...and this graceful Candle Stand/Pedestal Table is a faithful copy of an original Shaker design and an ideal project for practicing a variety of Lathe techniques.

TOP & BRACE

Start by gluing up the stock you'll need for the top, using 1/4" dowels or your Molding set-up Molding set-up to strengthen the joints between the adjoining boards. Allow to set and dry for at least 24 hours.

Locate your center, then cut the stock to a rough circle using your Scroll Saw or Bandsaw with a Circle Cutting Attachment.

Next, make the tabletop brace (B). Bore the holes for the mounting screws, then use your Disc Sander or Belt Sander to create the tapers on the bottom side of this piece.

Mount the Brace (B) temporarily to the assembled Top (A) with wood screws.

IMPORTANT: Mount the Brace (B) so the wood grain runs perpendicular to the grain of the Top (A) to prevent cupping and warping.

Adjust your Lathe for SLOW speed. Attach the Brace/Top to your 6" diameter Lathe Faceplate and start by turning the outer edge of the Top. Finally, turn



the shallow (1/8" deep) recess in the Top and finish sand the completed turning before removing it from the Lathe.

SPINDLE

Glue up the stock for the Spindle (C). Allow plenty of time for everything to dry thoroughly, then turn the Spindle and finish sand it before removing it from the Lathe

LEGS

Make a cardboard pattern for the legs, following the design in the drawing. To ensure the strength of the Legs, lay the pattern onto your stock so that the wood grain runs from the top to the bottom, as in the drawing.

Use your Bandsaw or Scroll Saw to cut them out (if you have a Bandsaw, you could pad saw all three Legs at once)...then sand them smooth using a Drum Sander. Round the edges using a Router Table Shaper with a Round-Over Bit or Radius Cutter. To round the concave areas where the Legs join with the Spindle, use a 1/1-2" diameter Drum Sander.

Next, drill the dowel holes in the Spindle/Pedestal (C) for mounting the three Legs at 120-degree increments around the circumference of the Spindle.

NOTE: Lay them out and drill them as accurately as possible, since you will have to mate them with matching holes in each of the three Legs during assembly. Be very careful not to drill all the way through the Spindle or the Legs.

Saw a kerf in the top of the Spindle; remove the Brace from the Table Top and mount it to the Spindle, using glue and tapping-in a small wedge to lock the two pieces together.

Attach the Legs to the Spindle with dowels and glue. Use a discarded, cut-up inner tube, wrapped around the Legs to hold everything together while the assembly dries (See Fig. 2).

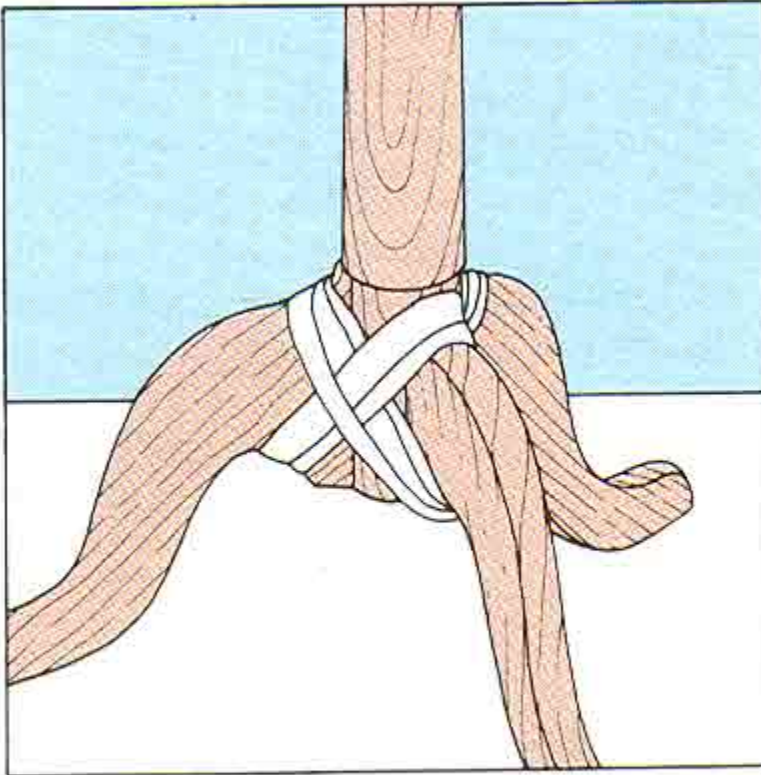

Fig. 2. Rubber from old inner tube interwoven around legs to grip and clamp equally.

Screw on the top and apply the finish of your choice.

Bill of Materials

(finished dimensions in inches)

Piece	Description	Size
A	Top (1)	16-3/8 dia. x 3/4
B	Brace (1)	3/4 x 4 x 14
C	Spindle/Pedestal (1)	2-1/4 dia. x 19-1/2
D	Legs (3)	3/4 x 4 x 12-1/2
E	Dowels (3)	3/8 dia. x 7.8
F	Dowels (6)	3/8" dia. x 1-1/2

Hardware:

#6 x 1" flathead wood screws (4)

#6 x 1-1/4" flathead wood screws (4)

Assembly Detail:

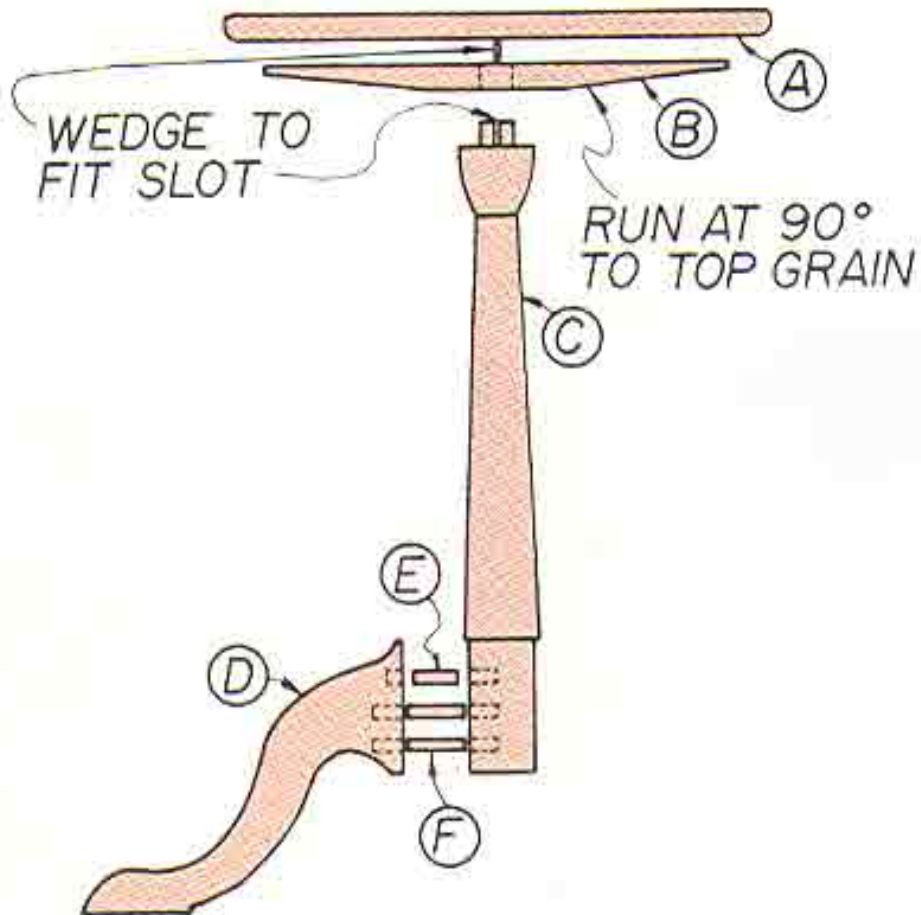

Leg Construction:

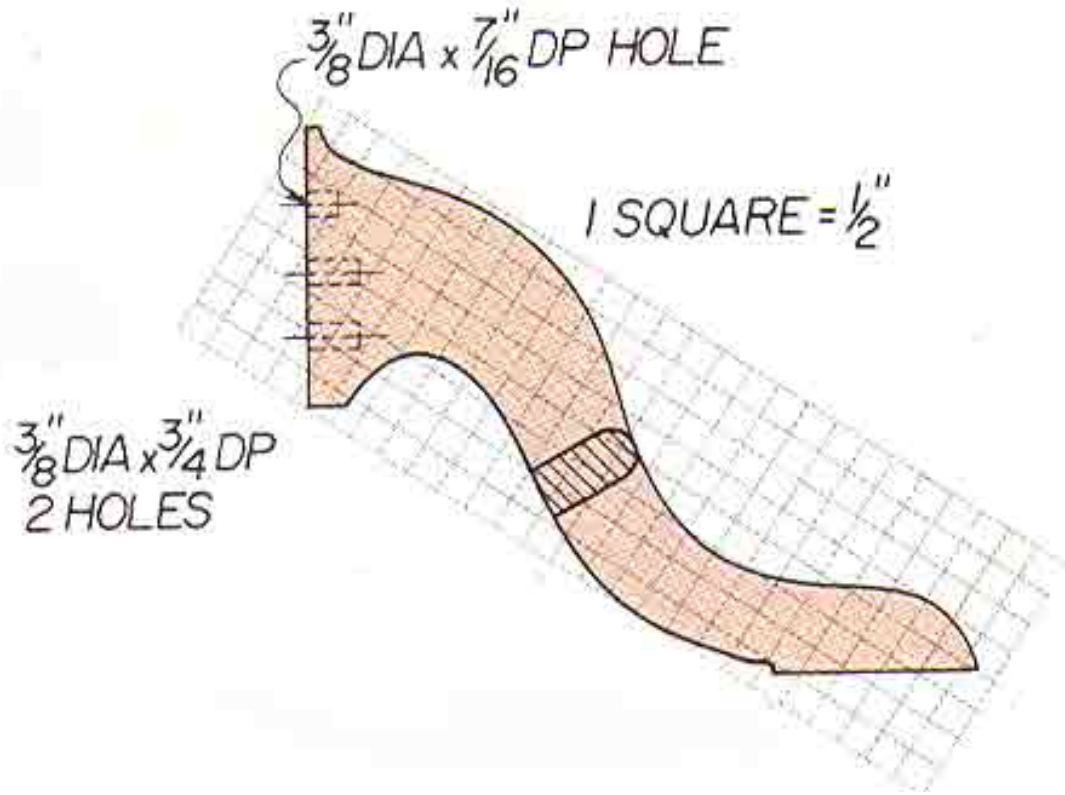

VERTICAL PAPER TOWEL HOLDER



Here's a simple, "turn-it-yourself" Paper Towel Holder that you should be able to make in record numbers...and, in record time, too!

The shape of the integral top knob (or finial) is up to you...as is the diameter and edge shape on the base (remember, some rolls of paper towels are larger in diameter than others)...so, get creative! Remember, too...that if your top knob (or base edge) is more elaborate than ours, you might also want to consider using a lathe duplicator to help you speed up the turning process.

- 1:** Prepare a 2" x 2" x 14" piece of stock for the vertical towel bar.
- 2:** Turn the towel bar according to your planned design.
- 3:** Sand the bar before removing it from the Lathe.
- 4:** Turn the round base on your lathe. (OPTION): Use your Bandsaw if you prefer.
- 5:** Drill and counterbore the bottom of the base to accept a 1/4" Tee-Nut.
- 6:** Drill a pilot hole in the bottom end of the towel bar to accept a 1/4" – 20 Hanger Screw.
- 7:** Assemble the holder and apply the finish of your choice.

TWO SHELF SIDE TABLE



We know....today, everybody has a cell phone attached to their belt, the side of their purse and even the dashboard of the car. After all, this IS the "mobile society", isn't it? Well....yes....but there are always those "hold-outs" who prefer to have a number of hard-wired phones distributed conveniently around the house.

Question is....where do you put them? Not every room has a convenient place for a phone...and even fewer yet have room to keep a phone book and notepad in close proximity. Enter this dandy little stand from the '80's. Even if you decide not to try and market these stands for use with the telephone, they'll also make great Side Tables for a small lamp and some reading materials.

So....before we get started, let's talk briefly about three things:

DESIGN

As you can see, our stand is really quite simple...almost "Shaker-Like" in its design. However, with just a few simple changes, its appearance can be altered completely. Change the handle cut-outs to a heart shape for a



"Country" look...or even use a more elaborate fretwork design of your own. Create a "Mission" look with tapered Sides and re-designed "legs". Cut the Sides off flush with the Top Shelf for a more contemporary look. Change the appearance of the Shelf Facings. Add a shelf for more utility. The options are endless.

JOINERY

The second of these three points has to do with the way this project goes together with sliding dovetail joints. In our example, we used "stopped" dovetails that are only visible from one side of the project. However, these could just as easily be full "through" dovetails where the joinery shows prominently from both sides. You might even consider making the Sides of maple and the Shelves of walnut to give your dovetail joinery a contrasting look. Another (much simpler) option would be to use straight dado joints instead of dovetails.

MULTIPLICITY

The final point has to do with the fact that each Stand/Table is quite simply comprised of only seven separate pieces of wood, cut into just four sizes. That's it. And that means you can build a bunch of these tables in almost the same amount of time that it would take you to make just a couple. The secret lies in the efficiency of your machine set-ups. With our example, you'll have just four ripping set-ups (12", 11-5/8", 2-1/2" and 1-1/2")...and four crosscut set-ups (31", 16-1/2" and 16").

For added efficiency, try "pad-sawing" the Side shape cut-outs and leg shapes in pairs if you're using your Scroll Saw or in stacks of up to six if you've designed them so you can use your Band Saw without having to make a "piercing" cut. You can hold your multiples together temporarily during this process by using some high-strength Double-Stick Tape. So, let's get started on building the design shown here.

Cut all stock to size, according to the Bill of Materials.

Use a Router Table with a 3/8" Dovetail Bit to cut the four 3/8" stopped dovetail grooves (11-3/8" long) in Sides (A) as shown in Fig. 1. Be sure to start both dovetail grooves at the rear of the Sides (A).

Cut the matching four dovetails on the ends of the Shelves (B) as shown in Fig. 2.

Using a Router set-up with a 3/8" Round-Over Bit, round over the front edges of the Shelves (B).



Using your Bandsaw or Scroll Saw, round off the tops of the Sides (A) and cut out the openings at the bottoms (that form the legs). Use Your Drum Sander to smooth the inside edges.

Drill starter holes in Sides (A) at their tops where the decorative areas are to be cut out (See Fig. 1). Use your Scroll saw to cut out the openings.

Cut the decorative edge on the fronts of the Shelf Facings (C). We used a Shaper Set-up with a Bead & Bevel Cutter (See Fig. 3).

Assemble the Shelves (B) to the Sides (A) using the dovetails, glue and some clamps. Wipe away any excess glue immediately with a damp cloth.

Install the Shelf Facings (C) and the Bottom Shelf Back (D) with glue and clamps. **NOTE:** The two Shelf Facings (C) should be attached flush with the fronts of the Shelves (B).

Finish with a stain of your choice. Suggested retail price: \$25 to \$80 each, depending on woods used, design and finish.

LIST OF MATERIALS –(finished dimensions in inches)

A	Sides (2)	3/4 x 31 x 12
B	Shelves (2)	3/4 x 16-1/2 x 11-5/8
C	Shelf Facings (2)	3/4 x 16 x 2-1/2
D	Bottom Shelf Back (1)	3/4 x 16 x 1-1/2

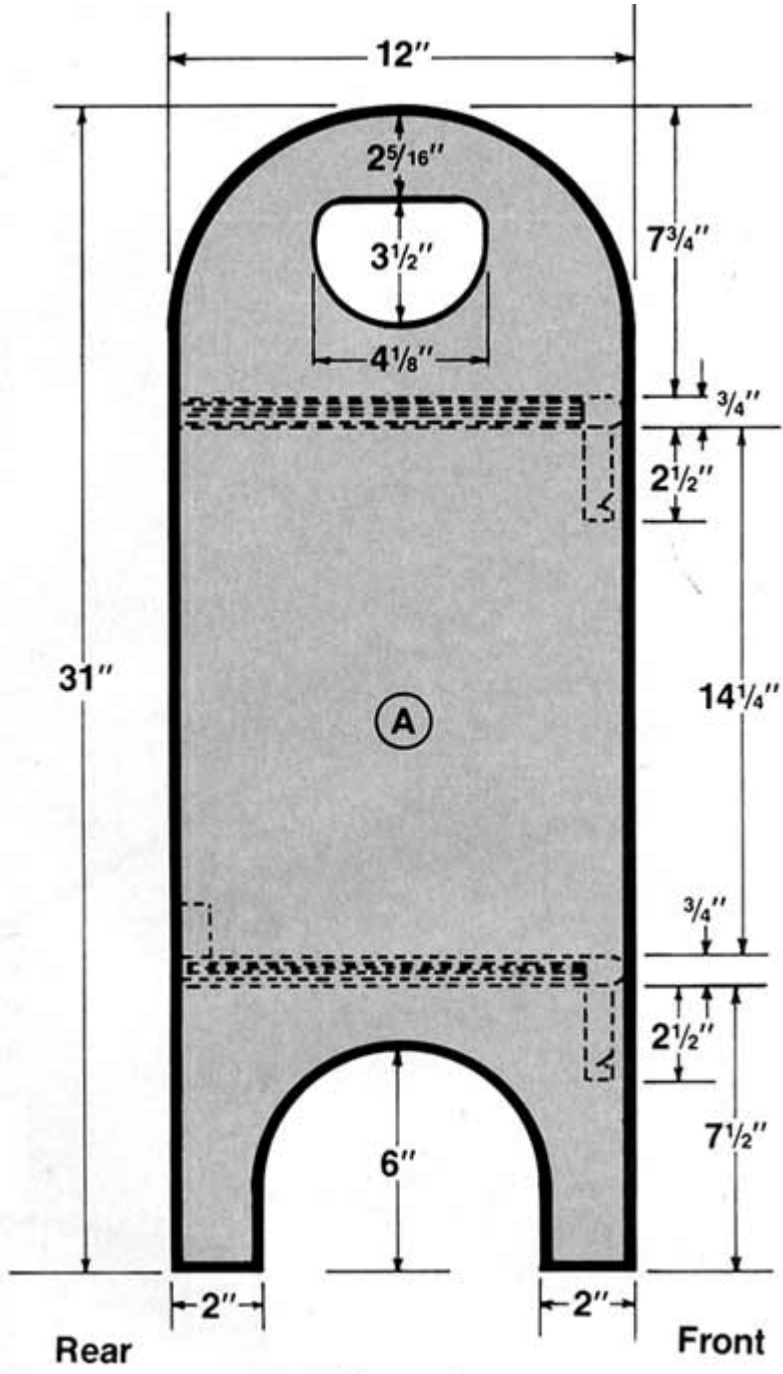

Figure 1

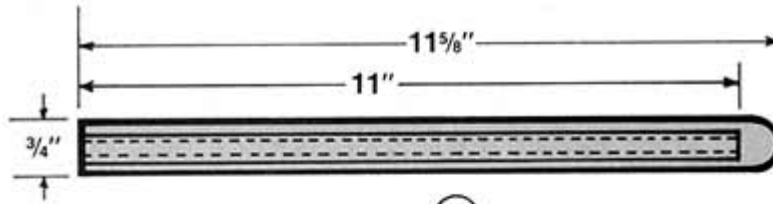
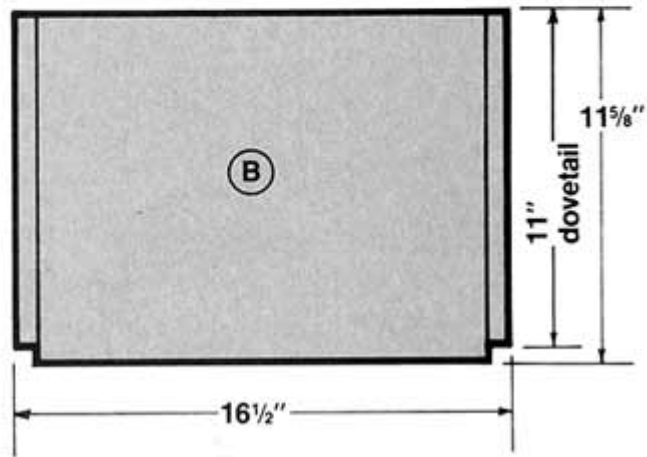

Figure 2

Rear



Front

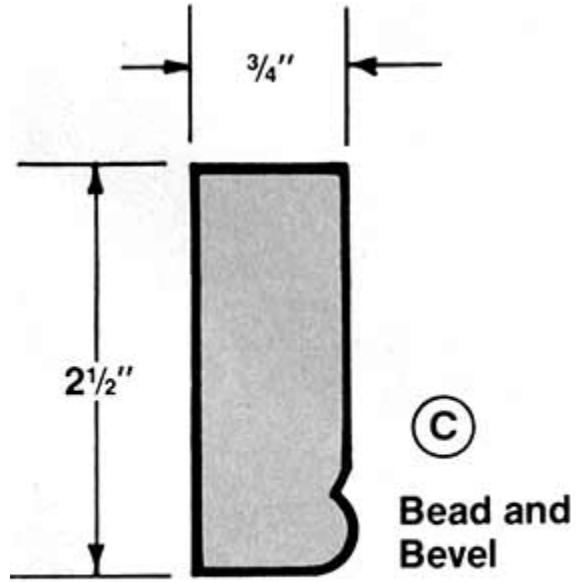
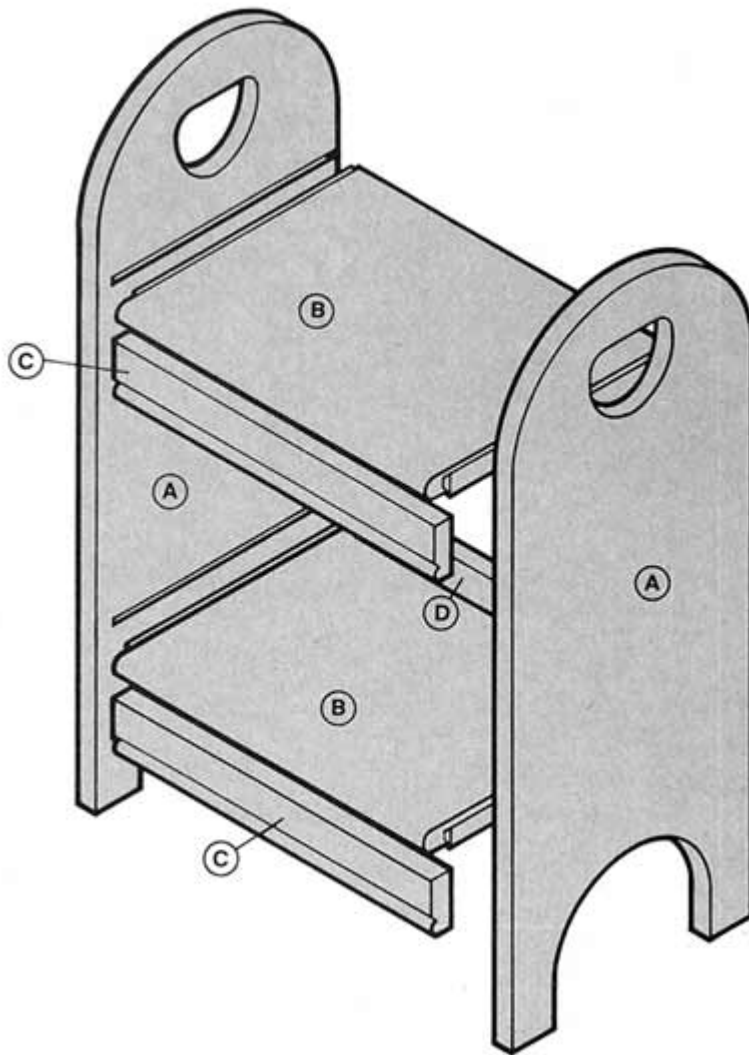

Figure 3
end view



SWINGING CRADLE

A wonderful heirloom-quality project that keeps on giving



One of the greatest joys in woodworking is to watch as the project you've made for someone is used and appreciated. This Pendulum Cradle will not only give you these pleasures, but will continue to be used and appreciated for generations to come. And, since this is true, you can consider it to be a true heirloom – a part of you that's destined to be around well into this century...and perhaps even the next.

Designed with simple, classic lines, the construction of this Cradle is very basic...and its joinery quite durable. Its most notable features include wide feet to prevent tipping, a locking pin on the basket, and knock-out wedges that allow you to break down the Cradle into just a few compact parts for easy storage and/or transport.

1: Glue up the stock where necessary, according to the List of Materials. A set of Double Bar Clamps will help you keep everything true while the glue sets. Use a portable belt sander to smooth the surfaces of the glued-up sections.



2: Transfer the patterns onto all of the parts that are to have contoured edges (A,B,C,D,E, & F). Mark the locations of the pivot holes in the headboard (E) and footboard (F). Do not cut out any of the contours yet.

3: Cut the mortises in the feet (A), posts (B) and stretcher (C) with the Hollow Chisel Mortising Attachment . If you don't have a Mortising Attachment, start with a 3/4" Router Bit...or drill several holes in a line, then clean out the ends with a wood chisel.

4: Cut the tenons on the bottoms of the posts (B) and ends of the stretcher (C), using your Dado set-up or an ordinary saw blade with a Tenoning Jig.

Once you've cut your tenons, round the ends of the stretcher tenons (NOT the post tenons) with a rasp.

5: Drill holes. First, insert the post tenon into the mortise in the foot...then drill the 1/2" dia. through holes for the dowels (P) that will be used to peg the cradle sides together (See Fig. 3). Then, drill the 3/4" dia. pivot holes in the posts (B), headboard (E) and footboard (F).

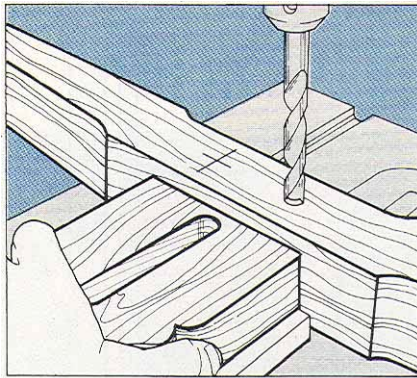

Fig. 1. Drilling the 1/2-in. holes for the pegged joint.

Finally, line up a post with the headboard and drill the locking pin hole through the post and into the headboard.

6: Cut the contours on the posts (B), stretcher (C), sides (D), headboard (E) and footboard (F), using your Bandsaw. Sand all of these cut edges using your Drum Sander or Disc Sander.

7: Assemble the feet to the posts with glue and 1/2" dia. dowels (P). Sand the ends of the dowels flush with the outside surfaces. Tip: Scrub off the excess glue with a wet rag. This works better than chiseling or sanding it off once it's dried.



8: Assemble the basket by attaching the sides (D) to the headboard (E) and footboard (F) with glue and #10 x 1-1/2" flathead wood screws. Use a 3/8" bit to counterbore the screw heads 3/16" below the surface and plug these holes with 3/8" dowels. You can use a Plug Cutter to make your own plugs from matching wood.

Use a portable belt sander to sand your plugs flush with the outside of the cradle.

9: Cut the cleat strips (G & H) to size and mount them to the inside of the cradle with #8 x 1-1/4" flathead wood screws.

10: Cut the bottom (Q) to size and bevel the two side edges. Sand all edges smooth.

11: Make the spacers (M) by first resawing 3/4" stock down to 3/8" thick. Draw the 2" circles on the stock and drill the 3/4" holes. Cut the washers on your Bandsaw or Scroll saw and sand the edges. Set aside.

12: Make the pivot pins (J) and the pivot lock pin (L). The pivot pins (J) are made from 3" lengths of 3/4" hardwood dowel. The caps to these are turned on the lathe using the screw center .

Once the pivot pins (J) are turned, use a jig to hold them while you drill the 3/4" x 1/2" deep holes for the pin (See Fig. 4). If you're using a good, durable hardwood such as cherry or maple, you can turn both pins from a single piece of stock.

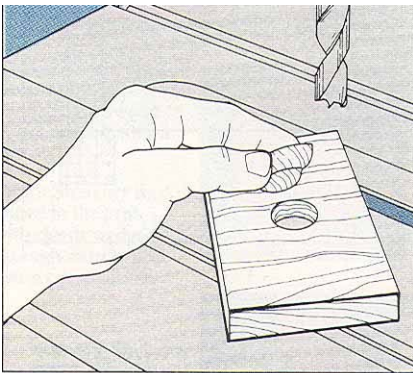

Fig. 2. Using a simple jig to hold the caps while drilling.

Finally, turn the lock pin (L) from a 4" length of 3/4" stock.



13: Make the wedges (N) for the post and stretcher joint. These wedges are cut to fit and should be centered and fit snugly with a tap from a mallet.

14: Finish sand all sub-assemblies with a fine grit sandpaper, then apply a non-toxic finish of your choice such as Preserve Oil (link to 521246 in on-line catalog)

Materials:

(finished dimensions in inches)

(ply = plywood -- hwd = hardwood -- pop = poplar -- peg = pegboard)

Piece	Description	Size
A	Feet (2)	2-1/4 x 2-1/4 x 24
B	Posts (2)	1-1/2 x 4-1/2 x 30
C	Stretcher (1)	1-1/4 x 4-1/2 x 42-3/4
D	Sides (2)	3/4 x 12 x 35
E	Headboard (1)	3/4 x 19-5/8 x 20-1/4
F	Footboard(1)	3/4 x 18-7/8 x 20-1/4
G	Cleat Strips (2)	3/4 x 3/4 x 33-1/2
H	Cleat Strips(2)	3/4 x 3/4 x 14-3/16
J	Pivot Pins (2)	3/4 dia. x 3
K	Pivot Pin Caps (2)	1-1/2 x 3/4
L	Pivot Lock Pin (1)	3/4 dia. x 3-3/8
M	Spacers (2)	2 dia. x 3/8
N	Wedges (2)	9/16 x 1-7/8 x 3-3/8
P	Dowels (4)	1/2 dia. x 2-1/4
Q	Bottom (1)	1/4 x 15-11/16 x 33-7/16

Hardware:

Qty	Description
	#10 x 1-1/2" flathead wood screws
	#8 x 1-1/4" flathead wood screws
	#6 x 1-1/2" flathead wood screws

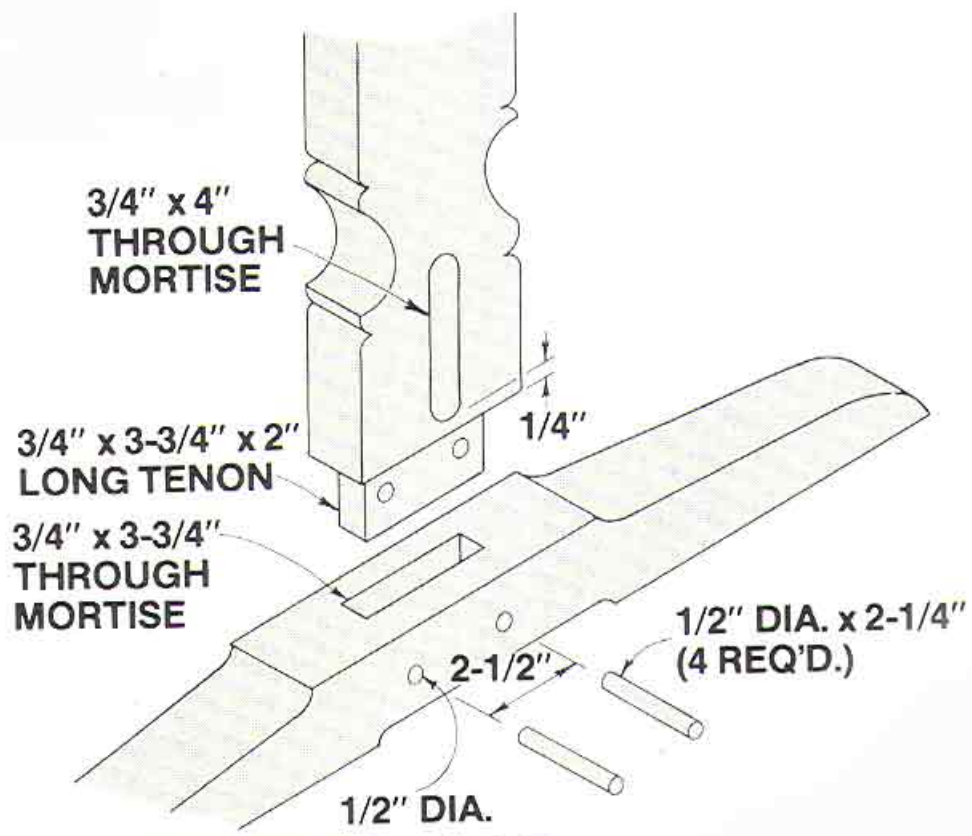

**POST TO FOOT
CONSTRUCTION**

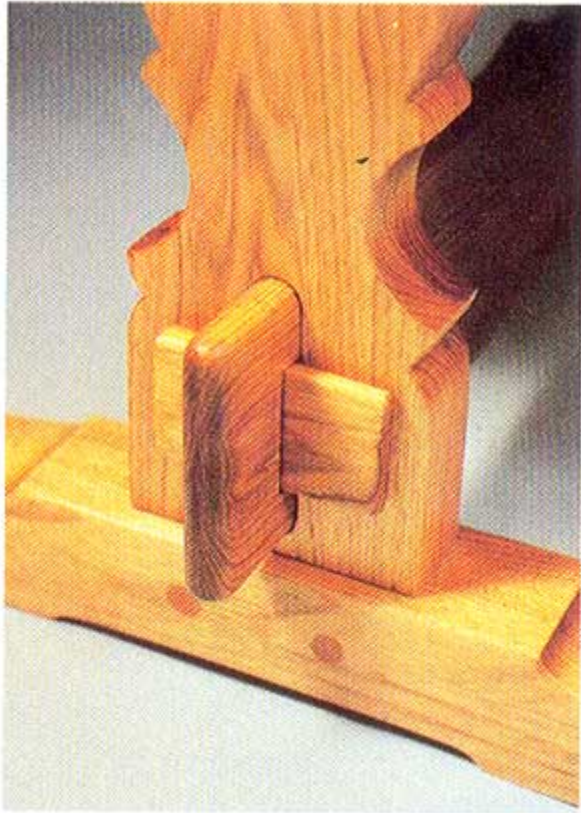

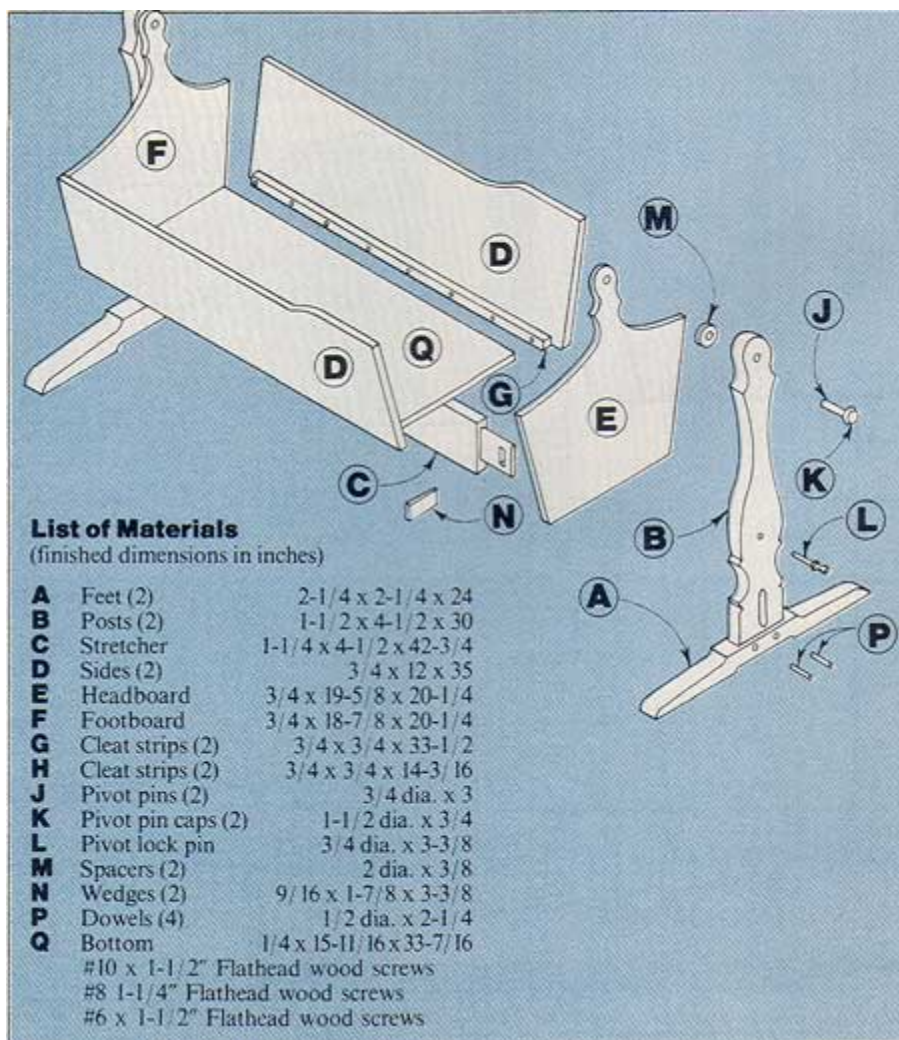

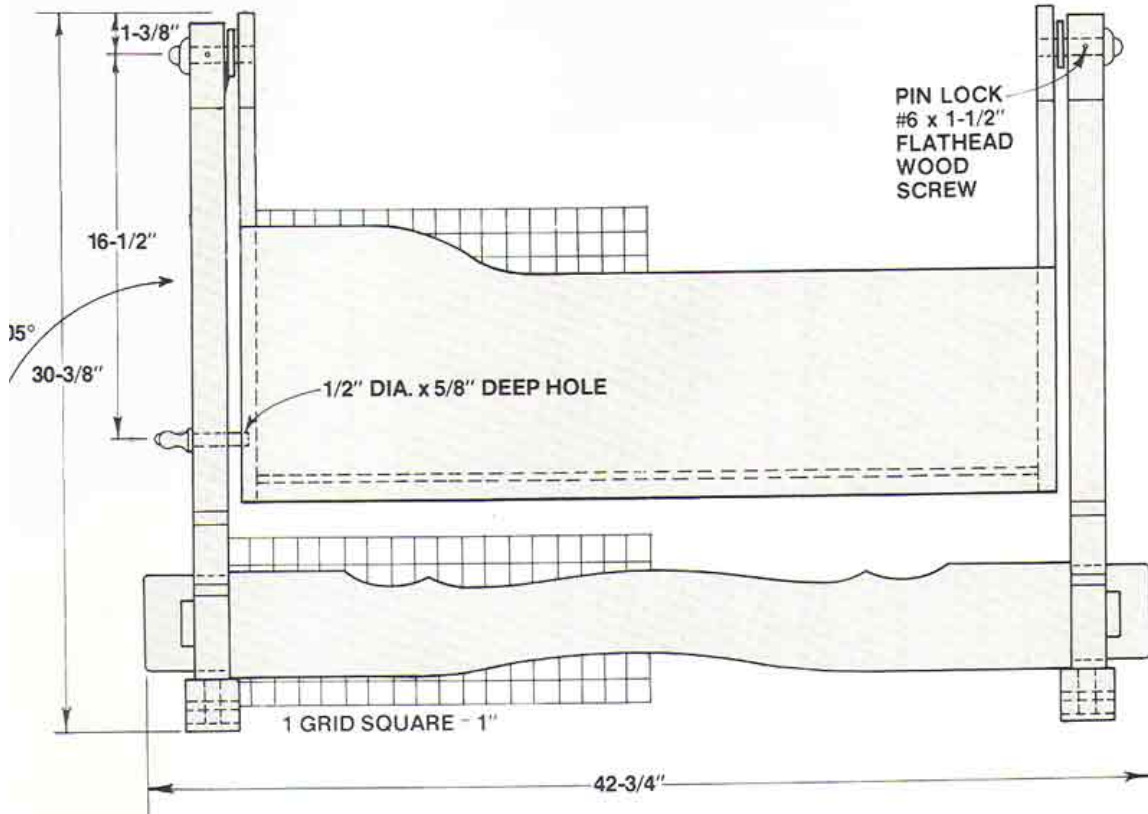

3/4" DIA. x 3" PIVOT PIN

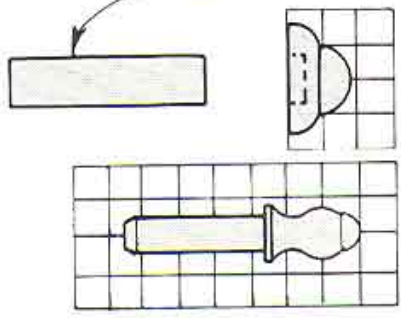

1 GRID SQUARE = 1/2"

PIN DETAIL

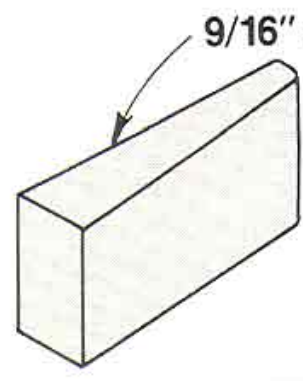

9/16" x 1-7/8" x 3-3/8"
WEDGE FITS
1/2" x 2"
THROUGH
MORTISE IN
STRETCHER.

SALT AND PEPPER SHAKERS



Start by deciding on your design. Ours is very contemporary with a simple rounded top and three small beads at the bottom. You may prefer something a bit more elaborate. Turn one or a few sets at a time out of full 2" x 2" or glued-up stock, as you prefer. Remember to leave glued-up stock clamped together for at least 24 hours before turning.

Following your design, make a durable template to guide you during the turning process. Set everything up so that you turn the Shakers with their tops toward your Lathe's Drive Spindle. We recommend that you size your Shakers so that you can turn a 3/4" long by 1/2" diameter tenon between each Shaker on your string.

These tenons will allow you to grip the Shaker strings with a 4-jaw Lathe Chuck during turning...and when drilling the cork counterbores and holes for the salt/pepper reservoirs. More about this later

First, place your stock between the Lathe Drive Center and Live Center and turn the first 3/4" long by 1/2" diameter tenon on the left end of each Shaker string workpiece. Once you've turned the tenons on the ends of all your workpieces, replace the Lathe Drive Center with a Lathe Chuck...grip the turned tenon on the first workpiece in your Chuck...and go to work, turning each string of Shakers and remembering to turn a gripping tenon between each Shaker.

Before removing each string of Shakers from the Lathe, finish sand them to the smoothness you desire. Once removed, use a hand-held razor saw...or



your Bandsaw or Scroll saw with a fine blade to separate the turned Shakers...remember...you must leave a 3/4" long tenon attached to the TOP of each Shaker when you separate them.

Turn your MARK V's Speed Dial to Slow, then turn off the Lathe. Replace your Lathe's Dead or Live Center with the Shopsmith Tailstock Chuck Arbor and attach your MARK V's Drill Chuck to it.

Insert a piloted drill bit of the appropriate size for the cork counterbore into your Drill Chuck (we used a 1-1/8" Forstner bit)...and align the drill bit pilot with the Lathe Drive Center. Replace the Live Center with your Lathe Chuck and mount the first separated Shaker into it (the Chuck). Set the Drill Press Depth Stop for the appropriate depth cork counterbore.

Turn on your MARK V and slowly advance the rotating Shaker into the stationary Bit to drill the cork counterbore in the first Shaker. Repeat the process for all remaining Shakers. Switch to the appropriate sized salt/pepper reservoir drill bit (we used a 5/8" Brad Point Bit) and follow the same process as you did when boring the cork counterbore holes. Repeat the process for all Shakers.

Saw the tenons off the tops of all shakers, leaving about 1/32" to 1/16" of the tenons proud of the top surfaces of each Shaker. Use your Disc Sander to slowly and carefully sand the tenon tops flush with the tops of the Shakers.

Use a 3/32" dia. drill bit in your Drill Press (or a hand-held portable drill) to bore the shaker holes in the tops. Drill four holes for salt and two or three holes for pepper.

Apply a non-toxic finish of your choice. We recommend a Salad Bowl Finish.

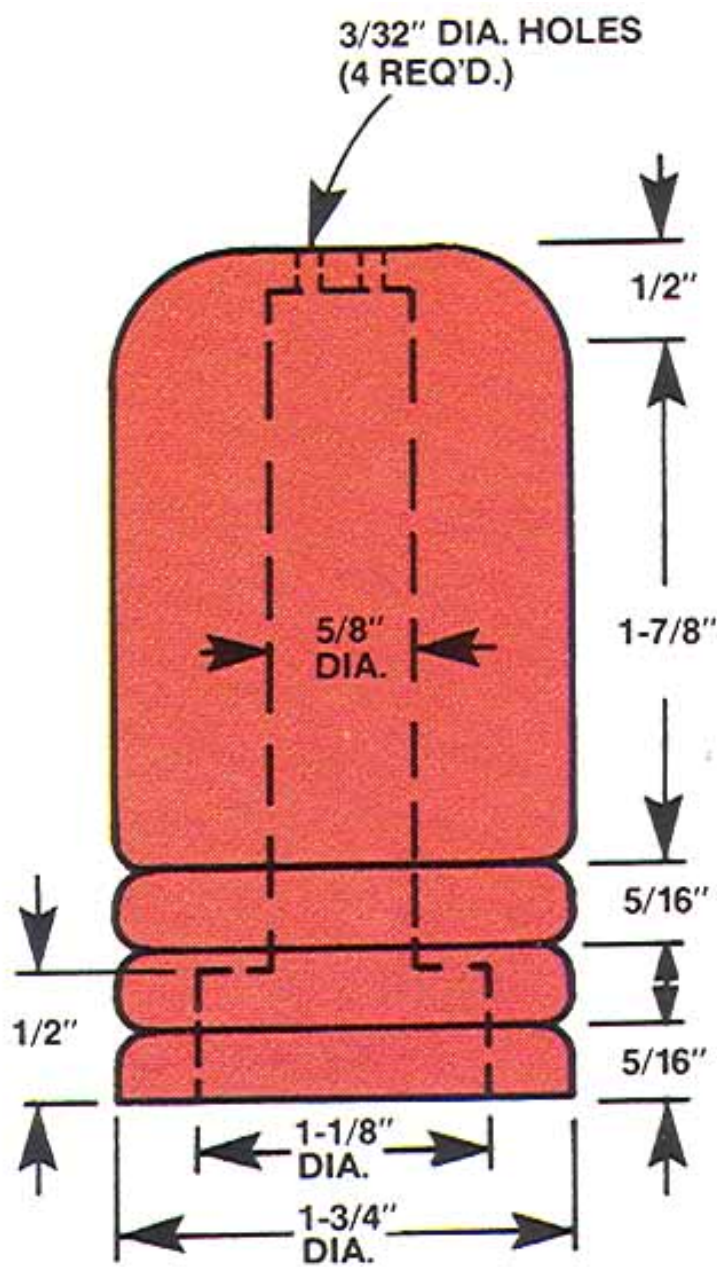

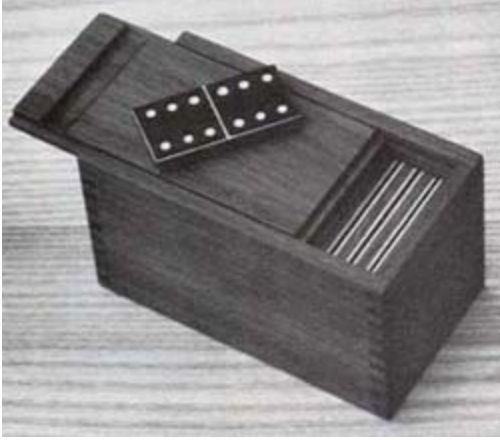

LAMINATED WOOD DOMINO SET

Made from your choice of contrasting domestic and/or exotic hardwoods, these laminated dominoes are real attention-getters at craft shows, street fairs and juried shows.

The set shown here was made with a 3/16" thick x 1-1/4" x 3-1/4" Red African Padauk (often called "Vermillion") core. Our core was then covered with a layer of holly veneer and then a layer of ebony veneer on each side.

Any contrasting light/dark woods will work. For example...a cherry core with maple and walnut veneers....or a mahogany core with ash and wenge veneers. The choice is yours. We think it's best to make your core from a medium colored wood, its surrounding veneers from a light-colored wood, and the top layers from a dark colored wood.

Start by ripping your core strips to the 1-1/4" width. Add glue, followed by a layer of light colored veneer, more glue, then a layer of dark colored veneer to each side. Clamp together and allow to dry thoroughly.

Crosscut 28 pieces to 3-1/4" long. Make a jig that you can use to hold your individual dominoes for Disc Sanding to final width and length. Use a Fine Disc and let your MARK V's Quill Stop control the consistency of all dimensions for you.

Once all of your dominoes are sanded to an identical size, mark their centerlines by making a very shallow (only as deep as your top layer of veneer) kerf cut with your Scroll Saw.



The dots are then revealed by drilling through the outer layer of veneer with a **SHARP, NEW** 1/8" twist drill bit. **Do not use a brad-point bit**, as they will leave an undesirable pilot hole in the center of each dot.



For mass-production, it's a good idea to make some jigs and fixtures to hold the dominoes and help you position the dots accurately, evenly and quickly.

Use some fine sandpaper to round-off all sharp edges slightly.

We made a finger-lapped box with a sliding top for our set...but a sliding top box with mitered, half-lapped or butt-jointed corners will work just as nicely.

THE FLYING TIGER P-40 AIRPLANE

Here's another great Norm Marshall toy – this one commemorating the P-40, a true WWII "ACE"



Back in the early stages of World War II, a group of volunteer aviators made history in the air over China. This group...known as The Flying Tigers...became world-famous for their victories against a superior Japanese air force.

Now, thanks to Norm Marshall, you can re-create those images of that glorious past in your own shop by making this great replica of The Flying Tigers' legendary P-40...and you should be able to easily complete it in a single, leisurely weekend. So, let's get started.

1: Cut all pieces to size according to the List of Materials.

NOTE: Because it can be difficult to guide a workpiece with irregular edges accurately through a resaw cut, we suggest that you start by resawing sufficient pieces of 1/4" and 3/8" thick stock to make all of your thinned parts (B,C,D,F,G & H) before cutting these parts to their final profiles.

Remember too, that it's always best to have extra resawn stock available in case of errors...and that it's much safer to cut small pieces from larger pieces of stock to help keep your hands out of harm's way. A little extra stock is a small price to pay for this added safety factor !



2: Fuselage. Tilt your Bandsaw Table to 5 degrees and cut the sides of the Fuselage (A). Tape the waste stock back onto the Fuselage and cut out your side profiles...including the Tail and Wing notches. Round all Fuselage edges to your liking.

3: Wing. Cut out the contour for the Wing (B), then drill the 3/16" holes in the full 3/8" thick leading (straight/front) edge for the Guns (N). Place the wing into position in the Fuselage notch and draw a line across the top of the Wing surface on each side, where it meets the Fuselage. Remove the Wing and use a conventional or Contour Sanding Drum to round the leading edge slightly and thin the trailing edge. Be careful not to sand past your lines on the top surface of the Wing or you'll have unsightly gaps where these two critical parts meet. Glue six of the Guns (N) into position.

4: Tail. Cut the contours for the Tail Pieces (C & D). As you did with the Wing, place the Tail Pieces into position in the Tail notch and draw lines across the bottom surface of the Horizontal Tail (C), where it meets the Fuselage. Remove the Horizontal Tail and use a conventional or Contour Sanding Drum to round the leading edge slightly and thin the trailing edge. Be careful not to sand past your lines to avoid unsightly gaps. Contour sand the leading and trailing edges of the Vertical Tail (D) to your desired profile.

5: Fairing and Cowling. Lay out and drill the 7/16" diameter holes in the Wheel Fairings (E) – and the 3/16" diameter holes in the Gun Cowling (G)...then use your Disc Sander to carefully shape these parts. Glue the last two Guns (N) into the Cowling (G).

6: Wheels. Use your Lathe and a 2" to 3" long piece of stock mounted to your Lathe Screw Center to turn, score and separate the 1-1/2" dia. x 1/2" thick wheels. Drill 7/32" diameter Axel holes in the Wheels (J) and 7/64" diameter Axel pilot holes in the Wheel Struts for the #12 x 1" long roundhead wood screw Axels.

Alternative method: Use a combination of 1-5/8" dia. and 1" dia. hole saws to cut out the Wheels and make the 1/8" deep score cuts for the tire lines.

7. Propeller. Use a 1-1/8" hole saw to cut the Propeller Hub (K) and Propeller Spacer (M) out of 3/4" and 1/8" thick (respectively) stock.

Glue the 1/4" dia. Propeller Shaft (L) into the Hub (K) and allow to dry thoroughly. Then, mount the assembly in your Drill Chuck and use a Rasp, File and Sandpaper to shape the Hub.

Cut the Propeller (H) from a piece of 1/4" thick plywood (for strength), shape the edges as you like with a Contour Sanding Drum and drill the center hole.



8: Exhaust Stacks. Use your Band saw or Scroll Saw to cut very thin, 1/8" deep saw kerfs to outline the Exhaust Pipes on the Engine Exhaust Stacks (F)...then cut each end of each Stack to the matching angle.
WARNING: Do not attempt this operation on a Table Saw, as these parts are far too small to handle safely.

9: Assembly. Glue parts (B,C & D) to the Fuselage (A). Glue the Propeller Spacer (M) to the front of the Fuselage, then drill the Propeller Shaft hole. Drill the angled Tail Skag hole and glue the Tail Skag (P) into place. Use the #12 Roundhead Screws to attach the Wheels (J) to the Wheel Struts (Q) and file off and screw points that protrude through the Struts. Use glue and clamps to assemble any remaining parts.

10: Decorate the Plane with Army Air Corps markings and the traditional shark's mouth. These decorations are easily made from colored contact paper.

LIST OF MATERIALS -

(finished dimensions in inches)

A: Fuselage 1-1/2 x 3 x 10-5/8

B: Wing 3/8 x 3-1/4 x 13

C: Horizontal Tail 1/4 x 2-1/2 x 6-1/4

D: Vertical Tail 1/4 x 2-1/4 x 2-3/4

E: Wheel Fairings (2) 3/4 x 3/4 x 2-1/4

F: Exhaust Stacks (2) 1/4 x 3/8 x 1-3/4

G: Gun Cowling 1/4 x 3/4 x 2-3/4

H: Propeller 1/4 x 6-1/2 dia.

J: Wheels (2) 1-1/2 dia. x 1/2

K: Propeller Hub 1 dia. x 3/4

L: Propeller Shaft 1/4 dia. x 1-3/4

M: Propeller Spacer 1 dia. x 1-1/8

N: Guns (8) 3/16 dia. x 1

P: Tail Skag 5/16 dia. x 1-1/2

Q: Wheel Struts (2) 7/16 dia. x 2-1/4

HARDWARE:

#12 x 1" Roundhead Wood Screws (2)

Design Copyright © 1985 Caryl Marshall. All Rights Reserved

Front View:

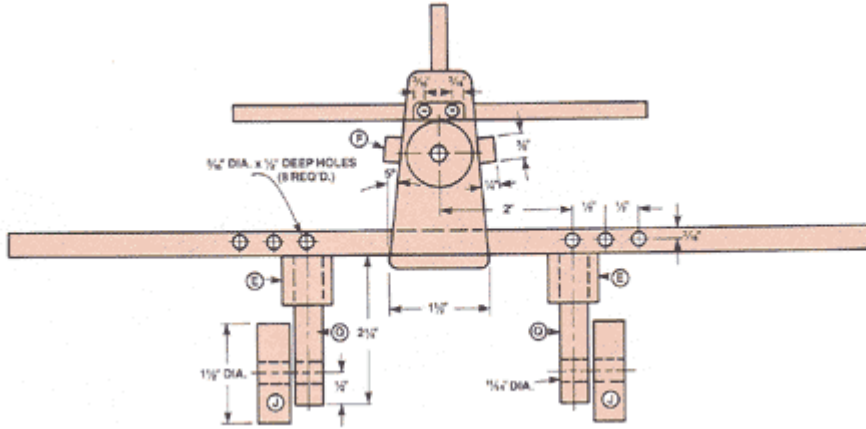

Wheel Detail:

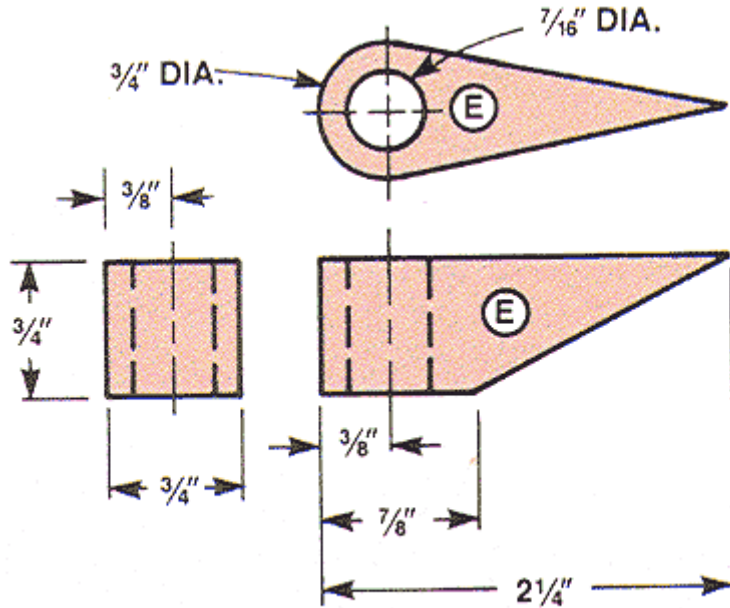

WHEEL FAIRING DETAIL

Prop Detail:

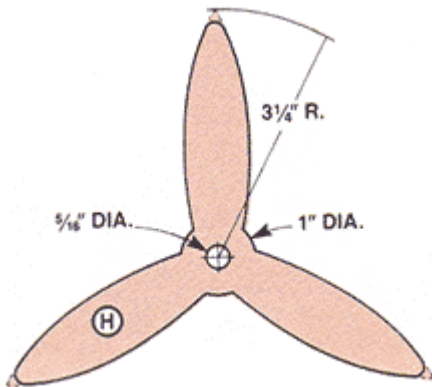

Side View:

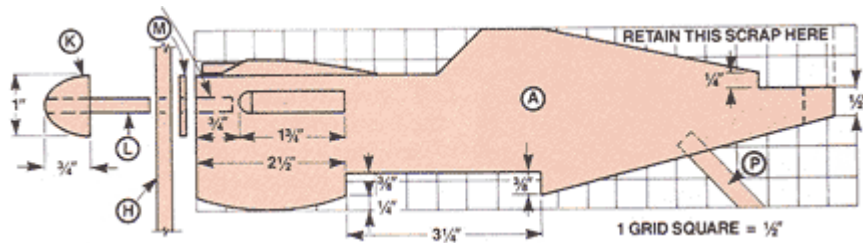

Top View:

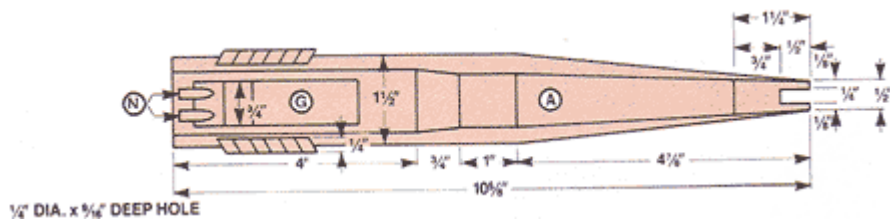

Stabilizer:

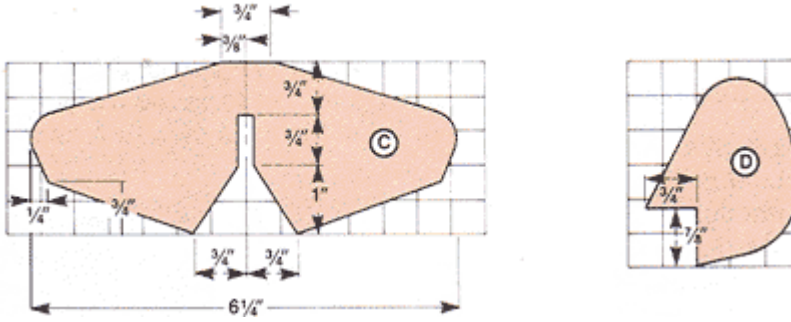

Wing Detail:

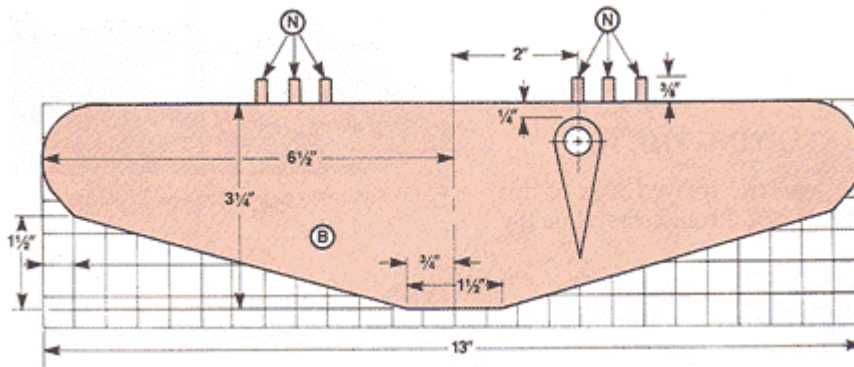



LAMINATED ROLLING PIN



The Rolling Pin was designed and turned by Rude (pronounced "Rudy") Osolnik, a master wood turner who was already retired from teaching generations of aspiring woodworkers at Berea College in central Kentucky when we met him and watched in awe as he originally created these two great projects for us in 1982.

Rude turned an amazing freeform bowl that now rests in Chicago's Museum of Science & Industry...and a laminated bowl that's part of the Smithsonian's permanent collection of fine woodworking projects by the top craftsmen from all over America.

According to Rude, "Working on the lathe is fun because it doesn't have to be bound by someone else's rules. Newcomers to the craft are realizing that they don't have to follow a textbook...and that once they've learned a few of the basics, it's a simple matter for each turner to develop his (or her) own style. It's a highly creative form of woodworking that you can start and finish on a single machine. Turn free-form and you don't even have to worry much about critical dimensions - just the overall design. The lathe leaves plenty of room for innovation and improvisation."

Work-Saving Production Note: Although we turned our examples using conventional Lathe Turning Chisels and workpiece mounting techniques, multiple copies of the Rolling Pin may be turned more quickly by using Shopsmith's Lathe Duplicator.



Here's an attractive, contemporary style Rolling Pin & Holder that's sure to be a real conversation-starter in anyone's kitchen. For our example, Rude used purpleheart, 11-ply Baltic Birch plywood (imported from Scandinavia & free of all voids), walnut and maple...but you can use virtually any wood species you desire. In fact, the more different woods you use, the better your chances of having just the right Rolling Pin for every customer who walks your way!

Rude has turned many of these graceful Rolling Pins for an East-coast gourmet magazine that used to offer them to their readers for \$35 each...way back in the late 70's and early 80's. In today's market, they're worth even more.

Start by gluing-up your stock to create a 2-1/2" x 2-1/2" x 18-1/2" block. To achieve the slanted grain effect, glue up a block that's at least 7" to 8" wide, then use your Bandsaw to slice the stock on an angle (See Fig. 1). Glue everything together using waterproof resorcinol or polyurethane glue so the Rolling Pin can be cleaned with soap and water after each use (that is, **IF** it's used, since a lot of your buyers will surely use it merely for decoration).

Cut on a bevel, turning the stock will open up a lot of beautiful grain, but you'll want to be careful that the exposed plies don't catch your Lathe Chisel and tear themselves as you turn the Pin.

Mount your stock between centers. To prevent burning, use a Ball Bearing Tailstock Live Center. Start by using your Gouge to rough your blank down to a smooth cylinder. Always hold your Chisel lightly to prevent jerky movements and keep from wearing yourself out from holding the Chisel too tightly.

First, use a pencil to mark the handle locations, then use an Outside Caliper and your Parting Tool to establish the diameters of the middle portion of the Pin and the Handle Knobs. Then, return to your Gouge and cut the Knob nearest the Tailstock first - making each Knob as wide as it is thick.

Switch to a Roundnose Chisel to create the sweeping transition areas from the Knobs to the Pin Body.

Once the basic shape has been turned...and while it's still mounted on the Lathe...sand the Pin with 80-grit, followed by 100-grit, then 180-grit sandpaper to achieve a super-smooth surface. Finish with Salad Bowl Finish or non-toxic Preserve Oil Finish.

The Holder is made from a piece of scrap wood that's 1/2" thick x 3-1/2" wide, with 3/8" dowels and a 1/4" diameter hole at the top for hanging it on the wall. It's just that simple.

Suggested retail price: \$35 to \$50

Figure 1:

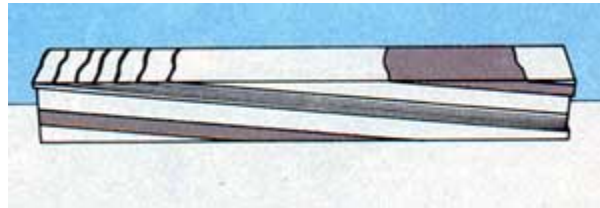
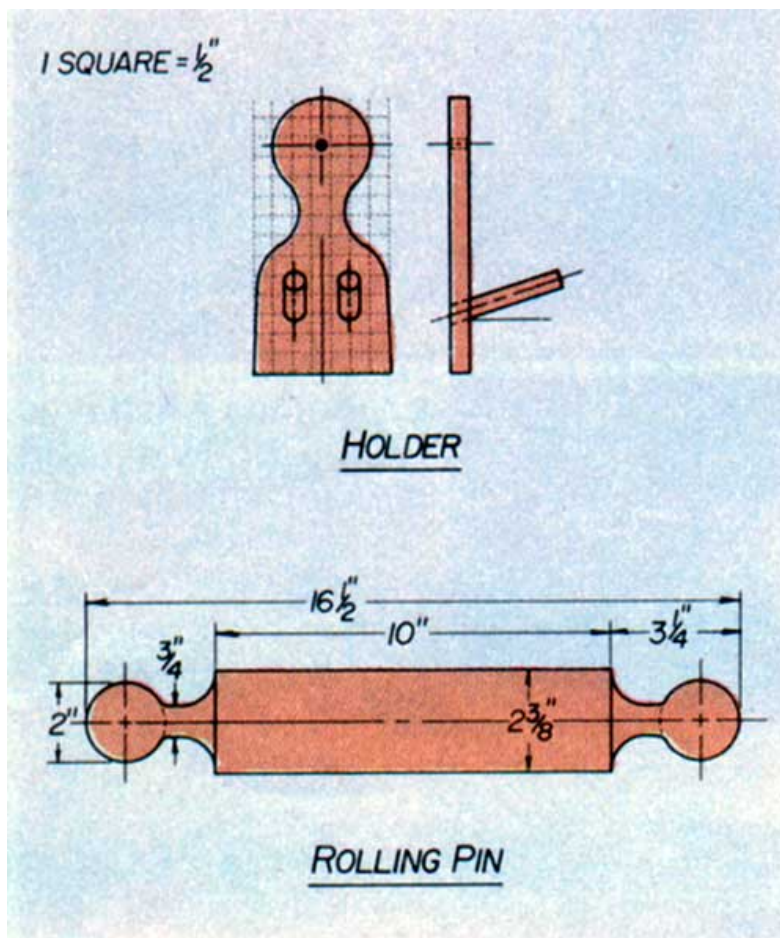
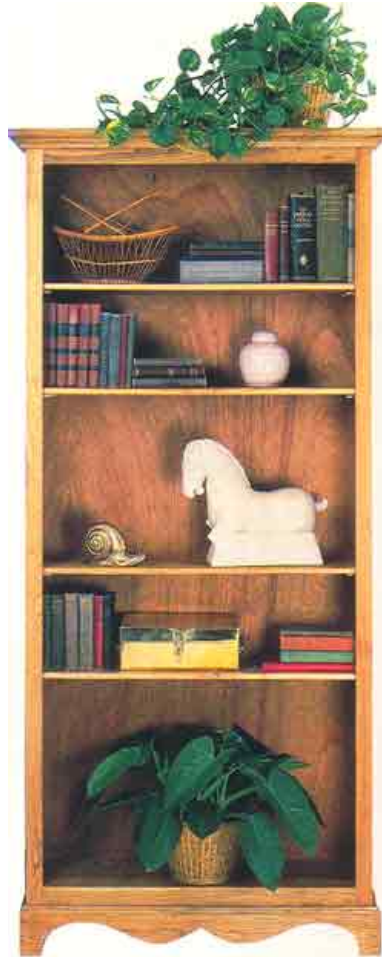

Figure 2:



THE ADJUSTABLE SHELF BOOKCASE



Five shelves (or more if you like) give you plenty of space for your favorite volumes and decorator artifacts, too

Simple bookcases are easy to build. A couple of sides, some shelves and a back...usually held together with some glue and a few nails. However, add just a bit of extra effort and you can dress-up that simple carcass with some accents that are sure to fit in with virtually any room décor. And, when you've finished, you'll have more than a simple bookcase. You'll have a top-quality piece of furniture that's sure to endure for generations.

A note about style and materials: As you can see from the photo, our example began with a simple, box-style carcass, then added bead-and-cove top and base moldings to give it a colonial or Early American look.



For a more contemporary look, make a box-style base with a straight-edged front (J) and sides (K) and a flush-edged top. For an oriental look, form 45-degree chamfered edges on the carcass, base, top and shelf edges. The design is so simple, that making changes for differing decors is an easy matter.

It's also important to note that we built our bookcase carcass (except for the back, of course) from solid red oak, although the sides, top and bottom could just as easily be built from 3/4" solid-core, veneered plywood. So, let's get started.

1: Stock preparation. Cut the sides (A), top (B) and bottom (C) to width. Note that all three pieces are the same 11-1/4" width.

2: Build the Case. Start by cutting the two sides (A), Top (B) and Bottom (C) to length. Next, use your Dado Set to cut the 1/4" deep by 3/8" wide rabbets in the back edges of these sides. These rabbets will house the back for the assembled carcass.

Next, cut the 3/4" wide by 3/8" deep dados in the sides to accept the Top (B) and Bottom (C).

Note that the Bookcase has adjustable Shelves that are supported by a "hole-and-peg" system using 3/8" dia. by 1-1/4" long dowels. These dowel holes must all be positioned in precisely the same locations for the shelves to rest flat on their support pegs (dowels) without wobbling.

To ensure consistency, start with a straight, six-foot long piece of scrap stock that's 1/2" to 3/4" thick and 1-1/2" or so wide. Make a pencil or scribe mark at every 1-1/2" along its length, then use this guide stick to mark the locations of the holes in each of the four pin rows.

Use your MARK V's Drill Press set-up with your Rip Fence set 2" in from your Drill Bit point to bore the four rows of 3/8" diameter holes to a depth of ". Dry assemble the Top, Bottom and Sides, then measure to verify the exact size of the Back (M) and cut it to size.

Use an extended open-time woodworker's glue and 6d finishing nails to assemble the Sides, Top and Bottom. Apply glue to the Back rabbets and use 4d finishing nails or small brads to nail the Back into these rabbets. Check to verify squareness three or four times during the assembly process.

3: Build the Face Frame. Cut out all Face Frame pieces (E, F, G). Use your MARK V's Horizontal Boring Machine set-up to drill the 3/8" dia. by 1-1/16" deep dowel holes that will be used to reinforce the joinery in these four



pieces. See the ASSEMBLY DETAIL drawing for approximate locations. Just be sure they're positioned identically on each end of the Top and Bottom Face Frames (E,F).

Assemble the Face Frame with 2" long dowels and glue, then attach it to the front edges of the Sides (A), Top (B) and Bottom (C) with glue and 6d finishing nails.

4: Create the Moldings. Use your Molding or Shaping set-up to create the decorative molding that will be used for the Top Front and Side Moldings (H,I). Refer to the TOP MOLDING DETAIL drawing when setting-up your machinery for making these components.

Cut your formed molding pieces to length and apply them to your carcass using glue and 4d finishing nails.

5: Build the Base. Cut all pieces (J,K,L) for the Base to size. Enlarge the pattern from the drawing and transfer it to the Base Front and Sides (J,K). Use your Bandsaw or Scroll Saw to cut out these Base pieces...then use your Drum Sander to sand all curved edges smooth.

Assemble, clamp and glue the three Base pieces (J,L) together. Allow the glue to dry thoroughly. Next, use your Molding set-up as shown in Fig 1. to create the Bead-&-Cove shape on the top edges of these three pieces.

Finally, with glue and #8 x 1-1/4" flathead wood screws, attach the Cleats (L) to the insides of the Base pieces. You can see their approximate positions in Fig. 1..and how they're attached in the BOTTOM CONSTRUCTION DETAIL drawing.

6: Cut & install the Shelves. Rip, then crosscut the Shelves (D) to size, then use your Shaper or Molder with a Nosing Cutter to shape the front edge of each Shelf.

7: Finish to suit. Sand the assembled project thoroughly, clean with tack cloth and apply the stain and/or top coat of your choice.



List of Materials

(finished dimensions in inches)

A	Sides (2)	3/4 x 11-1/4 x 78
B	Top	3/4 x 11-1/4 x 35-1/4
C	Bottom	3/4 x 11-1/4 x 35-1/4
D	Shelves(variable)	3/4 x 11 x 34-1/4
E	Top Face Frame	3/4 x 3 x 32-1/2
F	Bottom Face Frame	3/4 x 2-1/2 x 32-1/2
G	Side Face Frame (2)	3/4 x 1-3/4 x 78
H	Top Front Molding	3/4 x 2-1/2 x 40
I	Top Side Molding	(2) 3/4 x 2-1/2 x 14
J	Base Front	3/4 x 5 x 37-1/2
K	Base Sides (2)	3/4 x 5 x 12
L	Base Cleats (7)	3/4 x 3/4 x 4
M	Back	1/4 x 35-1/4 x 74-3/4 (to fit)

Hardware:

Dowels (8) 3/8 dia. x 2

Shelf Pins (dowels) 3/8 dia. x 1-1/4 *

Assembly:

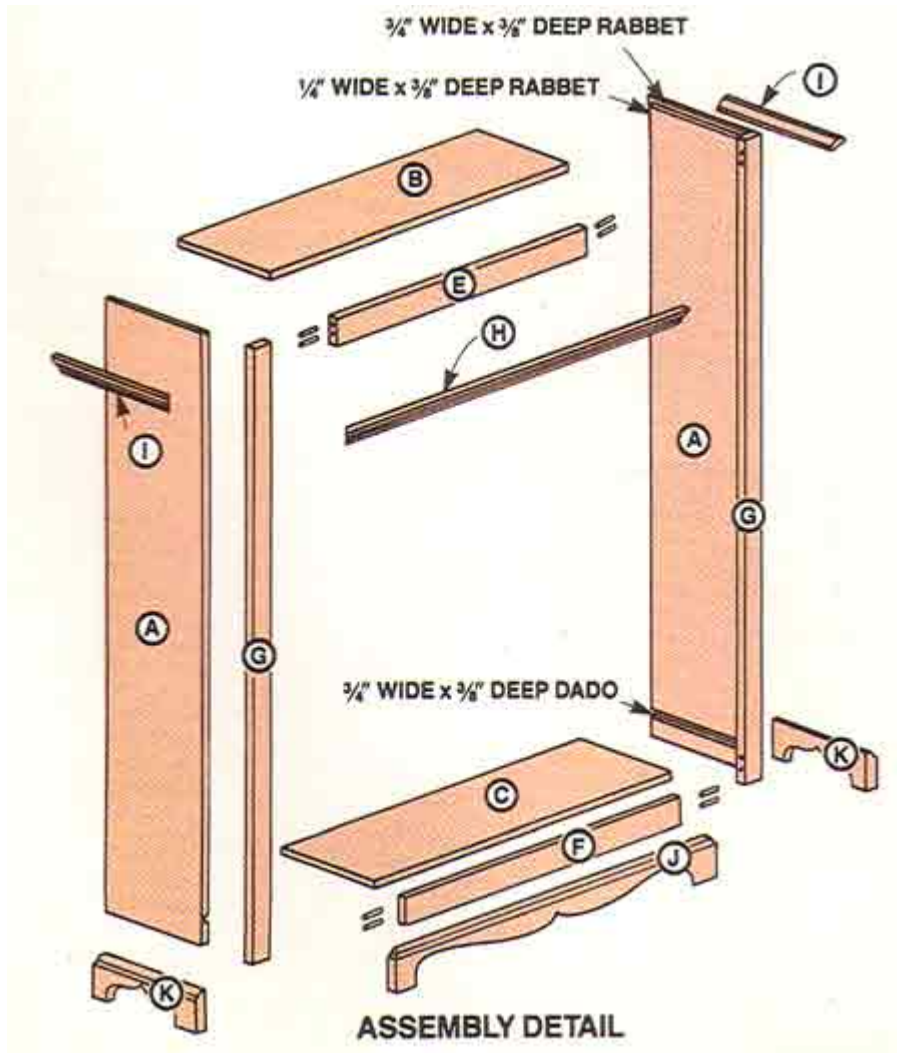

Top Molding, Base Molding, Shelf Edge Detail

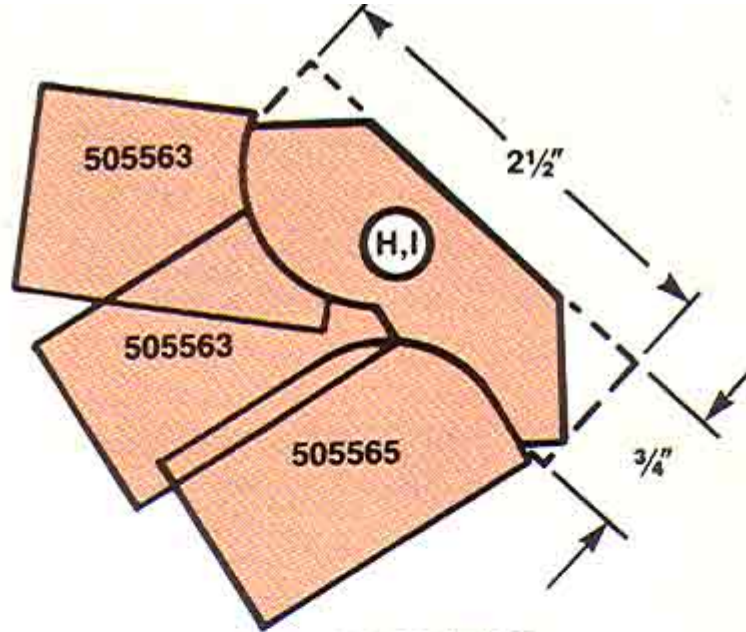

TOP MOLDING DETAIL

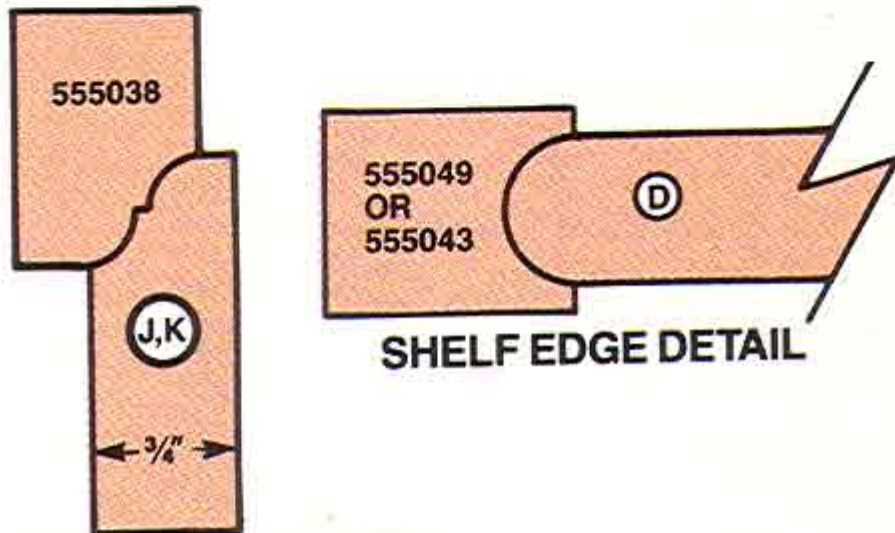

SHELF EDGE DETAIL

BASE MOLDING DETAIL

CONCORD TABLE



The Concord Table, also known as the candle stand table, is a traditional American Favorite. Our version lends itself to being a gift project because, by using a lathe duplicator, you can easily produce multiple spindles.

1. Cut stock to size according to List of Materials. Layout the spindle pattern (A) on a piece of 1/4" thick stock.
2. Use a scroll saw, Bandsaw or jigsaw to cut out the pattern and sand all sawn edges smooth. You now have the template for the lathe duplicator.
3. Mount the template on the lathe duplicator per your Owner's Manual.



4. Turn part A from a piece of 2" diameter x 21 1/4" stock.
5. Sand the spindle.
6. With the Mark V in the horizontal boring mode, drill the 3/8" diameter holes for the dowels "D" in the legs "C."
7. Use the grid pattern to layout the pattern for the legs "C."
8. Transfer the pattern to three pieces of stock 3/4" x 7 1/4" x 7 1/2".
9. Use a scroll saw, Bandsaw or jigsaw to cut out the legs. Save one piece of scrap from the outside curve for future use.
10. Use a drum sander to sand the curves of the legs.
11. Use a router with a piloted 1/4" rounding over bit to shape the curved edges of the legs. Do not shape the straight section.
12. Use a drum sander to sand a concave curve in the straight portion of the leg. This makes for a better fit when attaching the legs to the spindle.
13. Sand the legs and set aside.
14. Divide the base diameter of the spindle into three equal parts 120 degrees apart. Draw vertical lines on the base of the spindle to form the centerlines for the leg dowel holes.
15. Use dowel centers to mark the holes to be drilled in the spindle. In the vertical drill press mode, drill the 3/8" diameter holes in the spindle. Set up the table and rip fence to form a V-block to cradle the turning.
16. Glue and clamp the legs to the spindle, one at a time, to allow each leg time to set up. The scrap cutting from Step 9 will aid in clamping. With a square, check the bottom of the leg to assure it's square to the outside of the spindle.
17. Glue and clamp the stock to form the 16" x 16" piece for the top (B). Let glue dry for at least 24 hours.
18. Layout the 16" diameter circle for the top. Belt and surface of top blank smooth. **NOTE:**Mark the center for future use.
19. With a scroll saw, Bandsaw or jigsaw cut out the top (B).



20. Disc sand the edges of the top.
21. Use a router with a 1/4" Roman ogee bit to shape the top edge of B.
NOTE: The surface with the marked center should be on the bottom.
22. On the bottom of the table top, use a 1" Forstner or Brad-point bit to drill a 1" diameter hold through to brace (E).
23. Sand the table top.
24. Cut angled ends on brace with Bandsaw. Sand with disc sander or belt sander. Drill for screw holes.
25. Screw the top brace to the spindle.
26. Screw the brace to top.
27. Apply the finish of your choice.

LIST OF MATERIALS

Finished dimensions in inches

Piece	Description	Size
A	Spindle (1)	2 dia. x 21 1/4 stock
B	Top (1)	3/4 x 16 dia. Stock
C	Legs (3)	3/4 x 7 1/4 x 7 1/2
D	Dowels (10)	3/8 dia. X 1 1/2 (hardwood)
E	Top Brace (1)	3/4 x 3 x 12

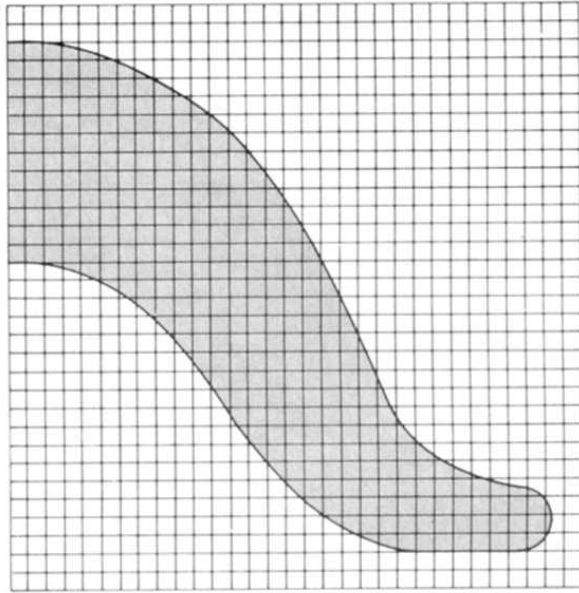

$\frac{1}{4}$ " Squares

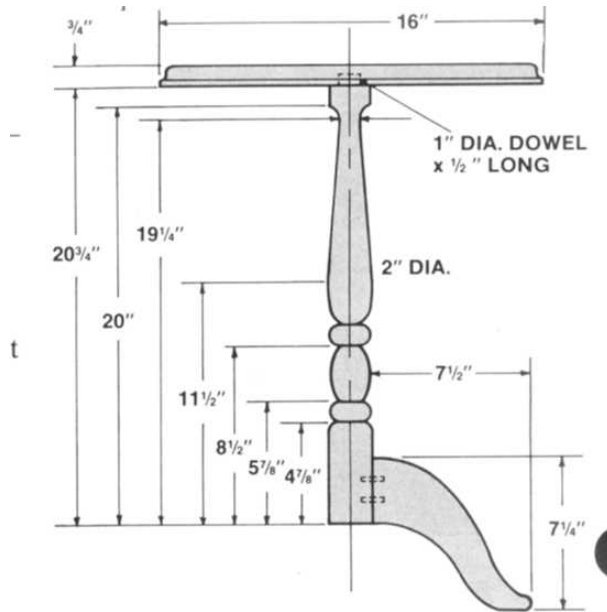

GATE LEG TABLE

24" x 36" of oval tabletop that folds out of the way to just 5" x 24" when needed



1: Prepare remaining stock. Use 3/4" stock for the main stretcher (E) and 5/8" stock for the remaining pieces. (See the Bill of Materials)

2: Glue-up the tabletop (L) and set it aside to dry. We started by preparing adjacent edges on the jointer. We then used the Shopsmith Biscuit Jointer with #10 biscuits to hold everything in alignment while the glue dried. As an option, you could eliminate the need for biscuits by using a set of 24" Double Bar Clamps to hold the boards in alignment while the glue dries. We added battens (K) to provide additional strength.

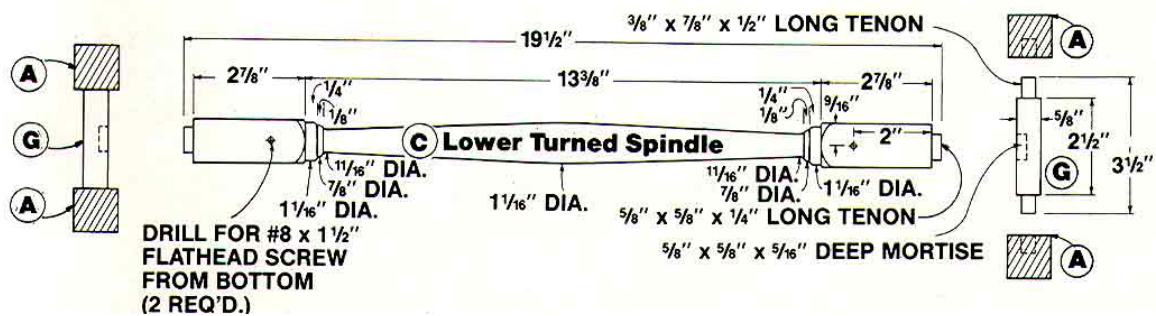
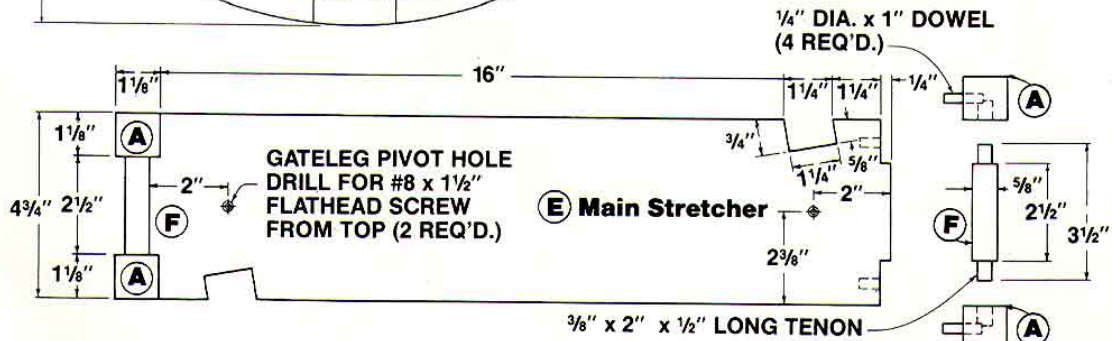
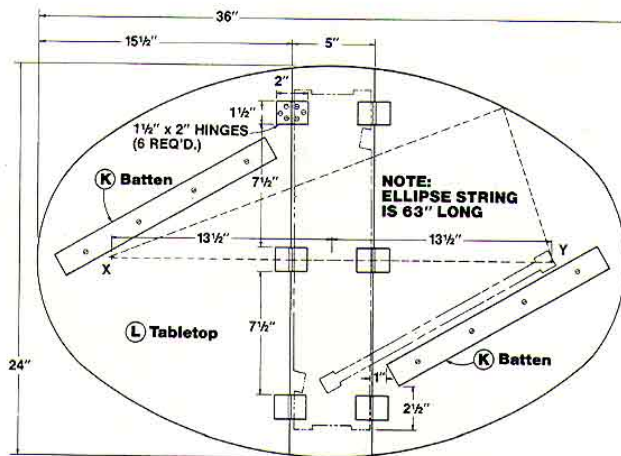

3: Cut the mortises in parts A,B & D for the stretchers. First, mark off the square sections on each leg, then the locations for the mortises (don't forget that each piece of turning stock is 1" longer than its intended finished length).

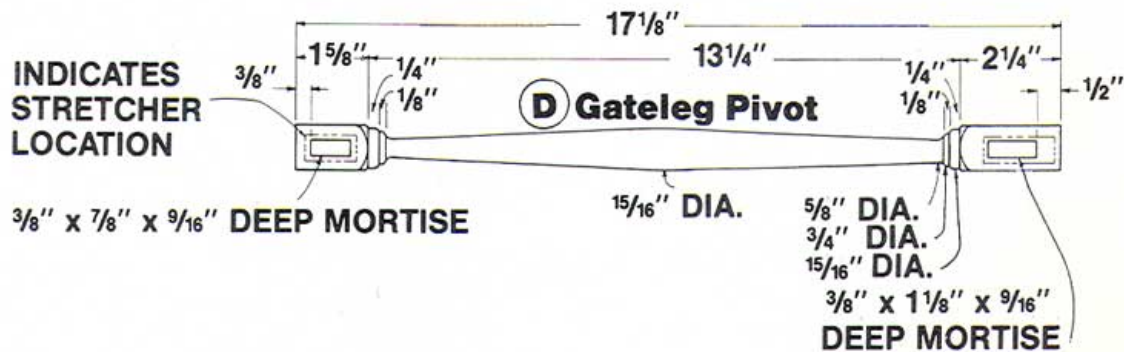
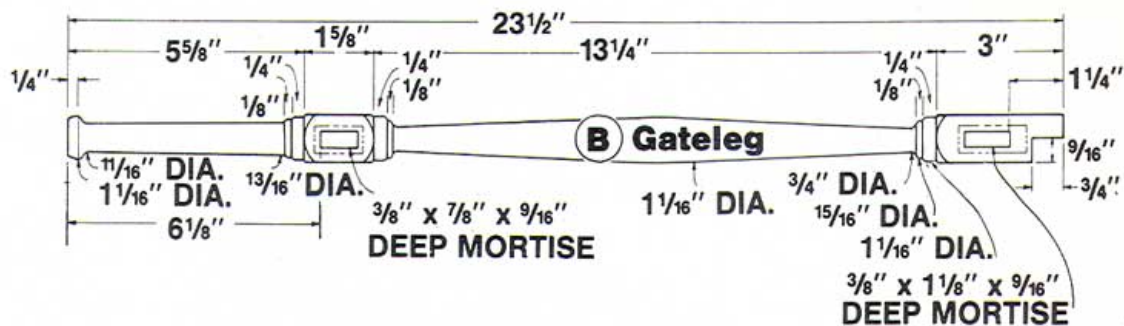
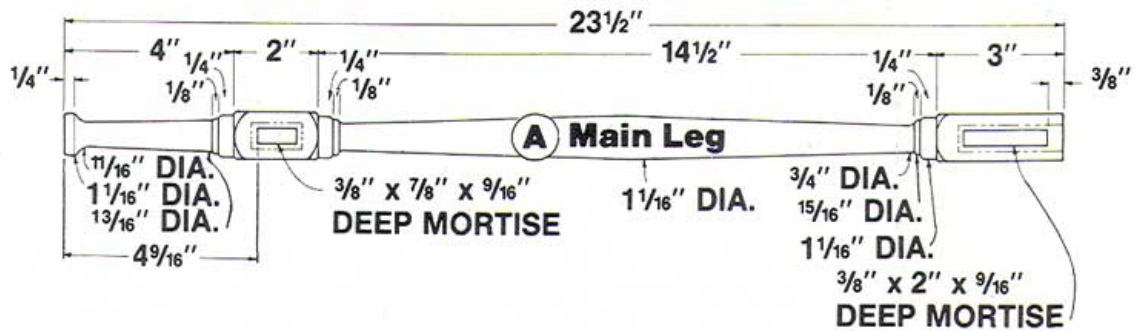

Use a Mortising Attachment with a 3/8" Bit & Chisel Set to do the job. Be sure to make each mortise about 1/16" deeper than its mating tenon to leave room for glue escapement.

As an alternative, you could also create the mortises with a Router Accessory, then square all edges with a chisel.

4: Cut the stretchers F,G,H & J to size. Use a Dado set-up or a Tenoning Jig to create the tenons on the ends. Important note: All tenons are 1/8" smaller in width and height than the stock, except for the tenons on the upper stretchers (F & H). Take an extra 1/4" off the tops of these tenons (3/8"

total). Doing so will prevent the tenons from splitting the tops of the turned legs (since they're so close to the ends).

The Gateleg Table Diagram (Leg Diagram)

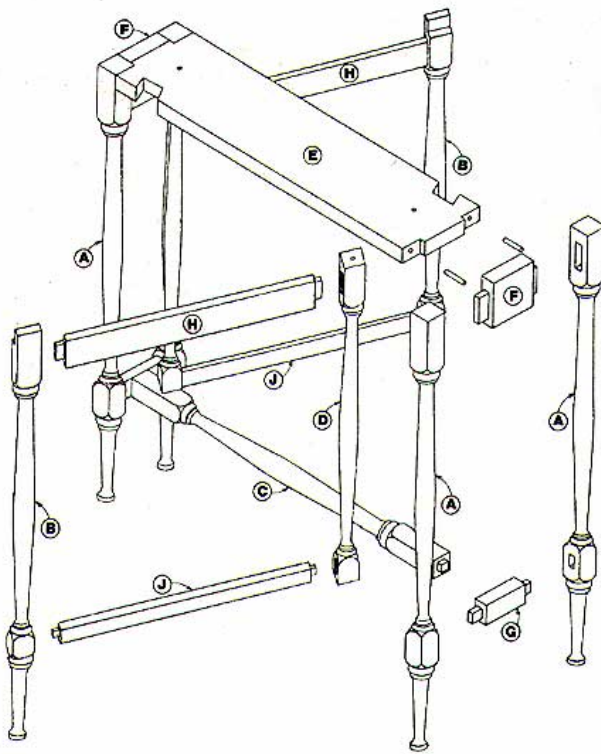

5: Turn parts (A,B,C & D). Accurately mark your turning centers on the ends of each piece. Use a soft mallet to avoid damaging your centers. Begin the turning process by roughing-to-round a 2" long section at the center of what will be the long tapered section. Sand it lightly, then install a Lathe Steady Rest to keep your long spindles from whipping during the turning process.

Start by cutting the shoulders, then round the turned sections. Form your design by turning the areas next to the squares first, then working your way toward the centers. Turn the feet as required (on parts A & B). Remove the Steady Rest and complete your turning by making light passes to reduce chatter. Finally, sand each turning while it's still on the lathe, using progressively finer papers and a slow speed.

6: Cut off the excess at the top (and bottom, if you so planned) of each turning and sand the ends square on the Disc Sander. See drawings for accuracy.



7: Cut and sand each turned piece to the exact, same length. If you have a MARK V, you can ensure that each leg is EXACTLY the same length by using your Disc Sander with the quill feed feature – and your Extension Table with the MARK V Rip Fence as a back-up.

8: Mark and cut the notches in the main stretcher (E) for the legs (A). Use your Band saw or Scroll Saw to cut the gateleg (B) notches.

9: Drill 1-1/4" dia. x 1/2" deep dowel holes in the ends of the main stretcher (E) and legs (A). Drill countersunk holes for #8 x 1-1/2" flathead screws in (E) and (C) for the gateleg pivots (D).

10: Dry assemble all leg assemblies, checking for fit and squareness. If the fit is OK, disassemble, then re-assemble using glue.

11: Cut tabletop (L) into the three parts. Joint the adjacent edges of the leaves, then clamp all three parts back together. Mark and cut the mortises for the hinges, using a hand-held or router set-up, followed by a chisel. If you use the latter, a Router Corner Chisel will make easy work of squaring the corners of hinge mortises made with a router. Mount the hinges.

12: Draw an ellipse on the bottom of the tabletop (see detailed tabletop drawing below for ellipse-drawing string length and pivot positions). We've provided simple instructions below for drawing ellipses. Secure a temporary batten on the underside of the tabletop to hold everything rigid, then cut out your ellipse on the Bandsaw or Scroll Saw, being sure to keep "proud" of your lines as you cut...so you can finish sand the edges to their final shape, using your Disc Sander.

How to Draw an Ellipse

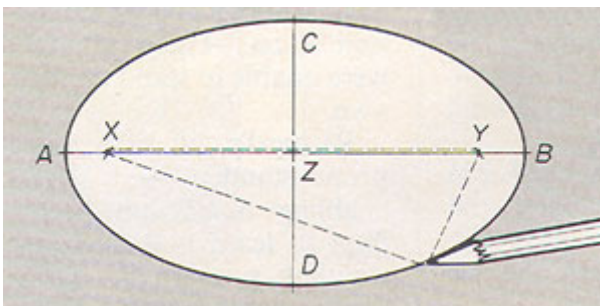

If AB is the major axis and CD is the minor axis, and they cross at point Z, set a compass or dividers (yardstick compass points may be best, depending on dimensions) to ZB or ZA. With the point at C, scribe arcs to intersect line AB at X and Y. Place a small brad at X and Y. Using NON-STRETCHING string, make a loop as long as AY. You'll get a perfect ellipse every time.



13: Shape the edge of the tabletop, using your Shaper set-up with a 1" dia. collar and the 3/16" Bead & Cove Cutter. Cut from below and make at least two passes. Make sure that at least 1/8" of the top is riding against the collar during your final pass. Use your Floating Extension Table and Telescoping Legs for outboard support if you have a Model 510 or 520 MARK V. If you have a Model 500 or 505 MARK V, we suggest that you support the front edge of your worktable with a Table Support Leg or custom-cut wooden leg to prevent worktable tipping during operation. Once you've finished forming the edge, remove the temporary batten.

14: Install the battens (K) on the underside of the leaves using #6 x 1" flathead screws. Be sure the battens are a minimum of 1" from the inside edge so they will clear the main stretcher (E) when the leaves are down.

15: Finish sand and apply the finish of your choice. Assemble the gatelegs and tabletop to the frame with screws. Enjoy !

Bill of Materials

(finished dimensions in inches)

Item	Description	Qty	Dimensions
A	Main legs	4	1-1/8 x 1-1/8 x 23-1/2
B	Gatelegs	2	1-1/8 x 1-1/8 x 23-1/2
C	Lower turned spindle	1	1-1/8 x 1-1/8 x 19-1/2
D	Gateleg pivots	2	1 x 1 x 17-1/8
E	Main stretcher	1	3/4 x 4-3/4 x 19
F	Upper stretchers	2	5/8 x 2-1/2 x 3-1/2
G	Lower stretchers	2	5/8 x 1-1/8 x 3-1/2
H	Upper gateleg stretchers	2	5/8 x 1-5/8 x 15
J	Lower gateleg stretchers	2	5/8 x 1-1/8 x 15
K	Battens	2	5/8 x 1-1/2 x 14-3/4
L	Tabletop	1	5/8 x 24 x 36

Miscellaneous

1-1/2" x 2" hinges (6)
#8 x 1-1/2" flathead wood screws (4)
#6 x 1" flathead wood screws (14)
1/4" dia. x 1" dowels (4)

SLANTED GOURMET KNIFE BLOCK

A simple project that's sure to look great on any kitchen countertop



Keep fine kitchen cutlery handy and sharp with this attractive knife block

Next, set up your table saw with a ripping blade set at slightly higher than half the thickness of your Body (A). Remove just enough stock from the opposite face to make it square by running the previously sanded side against your rip fence. After making your cut, flip the Body over and complete the through-cut by making a second pass. The top of the Body is then made square by cutting it on a Bandsaw with a sharp, 5/8" blade and a Miter Gauge. Then, belt sand the top using the Belt Sander Table and your Miter Gauge to true up the Body (A). The Body block is now totally squared-up.

Cutting the Retaining Strip slots

First, you need to cut the slots for the Retaining Strips (B). Follow the dimensions in Figure #1 and use your Dado set-up to cut 1/4" deep x 5/16" wide slots, as shown. First, cut the two upper slots, using your Rip Fence as a guide. Then, rotate the Body 90° to the next side and repeat the process. Be sure to cut slots on the back and two sides. To cut the bottom slot on the back side, use your Miter Gauge as a guide and NOT THE RIP FENCE.

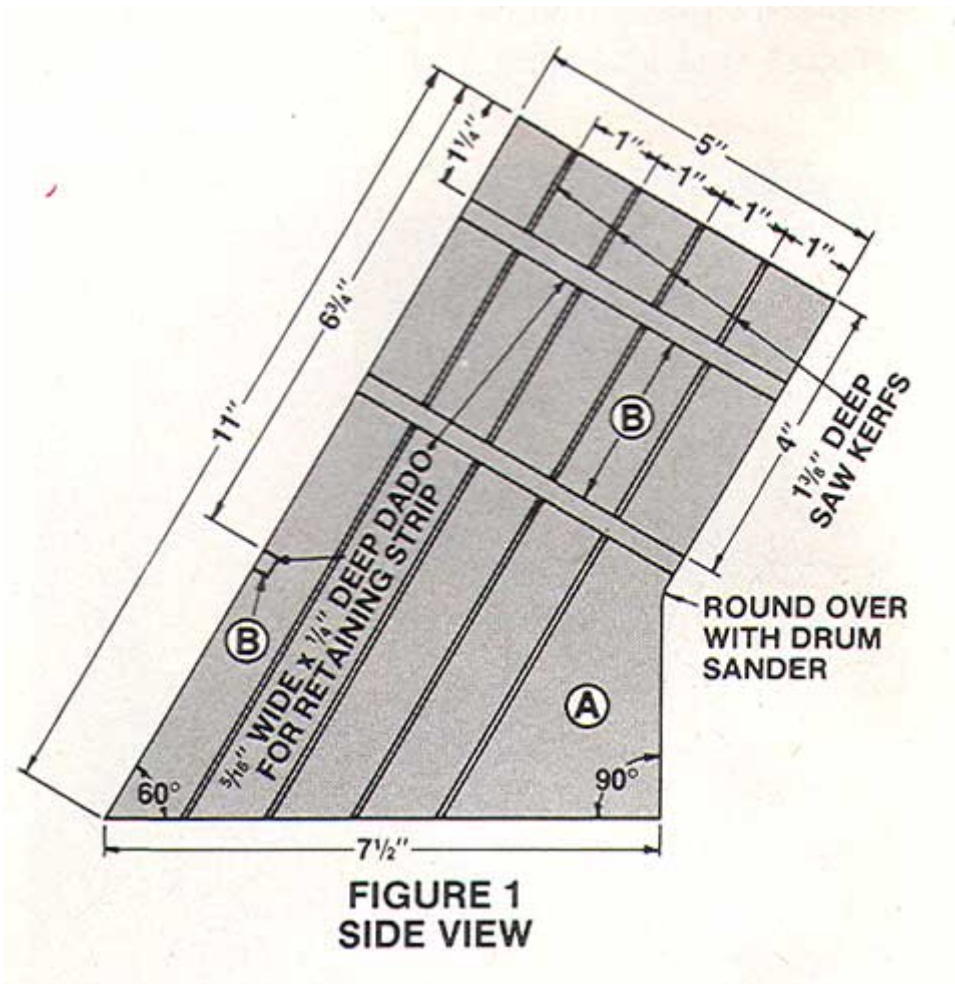

Shaping the Body

Follow Figure #1 and lay out the pattern for your Body shape. Use your Bandsaw with a 5/8" blade to cut out the profile. Belt Sand the bottom and the flat surfaces of the angled front. Use a 6" tall Drum Sander to round the inside corner.

Cutting the knife slots

The knife slots are easily cut by following Figure 2 for positioning, then making one pass on the Table Saw with a Rip Blade set at a depth of 1-3/8". The sharpening stone slot is made by setting your Dado accessory for a 1/2" wide x 1" deep cut. NOTE: For safety, make the dado cut in a series of passes so as not to remove too much stock at once.

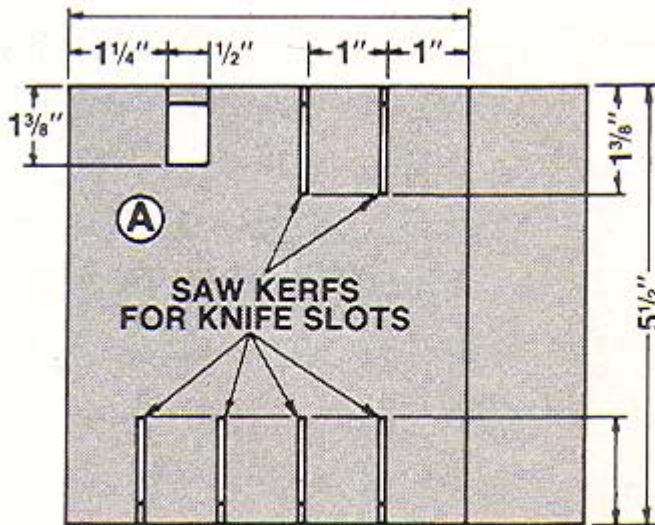

FIGURE 2
TOP VIEW

Making the walnut Retaining Strips

Using your Bandsaw, resaw stock for the Retaining Strips (B), making them slightly thicker than the 1/4" depth so they can fit tightly in the slots and sanded flush and smooth with the surface later. On any ends of the Retaining Strips that will form a joint with another Retaining Strip once assembled, use your Disc sander and Miter Gauge to sand the mating ends to create tight-fitting 45° corner miter joints. Glue all Retaining Strips in position. Once the glue has dried, belt sand the assembled Body and Retaining Strips smooth with 150-grit sandpaper.

Finishing Touches

We coated our knife block with a non-toxic Salad Bowl Finish and recommend that you do likewise for safety's sake. To be sure the insides of all slots are coated, you could dip the finished Body in a pan of finish...or sit it in a pan



and pour the finish over it, if you prefer. After it drips for 15 minutes or so, pour any finish back into your can. Wet sand with 320 to 400-grit paper to attain the desired luster.

Suggested retail price: \$30 to \$50

KNICK KNACK CABINET



1: Cut all pieces according to the list of materials. Cut pieces A through F from 3/4" stock, and the back panel from 1/4" plywood. Then cut one 3/4" x 2-5/8" x 13" piece and two 3/4" x 2-5/8" x 15" pieces (these will be resawed later to make the dividers and interior shelves - G through K)

2: Make a template (pattern) for the top (B) and bottom (C) shelf rails...and an end pattern for the sides (A). Use the top template to mark the center point for the circle on the top shelf rail (B), and use a compass to draw it on the wood.

3: Use your bandsaw to resaw the three pieces you made for G through K. Saw along the center (3/8") lines and save both sides of each piece. You'll have four 3/8" x 2-5/8" x 15" and two 3/8" x 2-5/8" x 13" pieces. Use your Jointer or Belt Sander to reduce these pieces to a thickness of 1/4".

4: Cut the pieces to length.

5: Cut 18-3/4" long stop rabbets in the sides (A). (NOTE: If one side of these pieces looks better than the other, select the best side as the outside, and make the rabbets on the opposite side.) These 1/4" deep rabbets are to accept the cabinet back (L). ...then clean up the ends of your cuts with a chisel.

6: Cut rabbets along the full length of the top and bottom shelves (D).

7: Sand all pieces to final smoothness.



8: Test assemble sides (A), top and bottom shelves (D), top and bottom shelf rails (B, C) and back panel (L). Lay the back panel on a flat surface and dry fit the sides, top and bottom shelves and top and bottom shelf rails around the back panel. Make sure that all parts fit together squarely and tightly.

9: Check fit of interior shelves and dividers...then assemble pieces. Be careful to get the glue ONLY between the two pieces to be glued. If the glue sets on an exposed part of a piece of wood, that part will not take a stain properly.

10: Glue and clamp the Cabinet frame pieces in place around the back panel. DO NOT glue the back panel in place yet. When the frame is dry, remove the clamps and the back panel, then drill the mounting holes. Sand away any roughness left by drilling.

11: Lay the cabinet frame face down on a clean, flat surface and glue the back panel in place. Put the glue in the rabbets to avoid smearing it where it's not wanted. Use 3/4" long brads to tack the back panel into position.

12: Once the glue's dried, place the cabinet on its back and mark the inside of the back to show where the dividers will go. Also mark the inside of the sides to show where the shelves will go.

13: Dry-fit all shelves and dividers into place in the cabinet. If you have to sand any pieces to get a good fit, mark them and be sure to return them to the same spot when you glue. Then fasten the dividers to the shelves using glue and small brads. Slip the entire assembly of shelves and dividers into the cabinet frame, then nail the assembly in place with brads through the cabinet back panel.

14: Cut rabbets in the door frame pieces (E, F). Pick the best sides of the door rails and stiles. Mark the pieces so that the rabbets for the glass and corner miters will be in the right places to allow the best sides of the wood to be on the outside.

15: Cut the miters on the ends of the door frame pieces...then cut the kerfs for the splines. Always be sure to keep the same (outside) side of the frame piece towards the rip fence when cutting the kerfs, so they'll align properly when you insert the splines.

16: Cut the four splines and shape the ends. Dry fit the door frame together and check for squareness. Glue each mitered corner, in and around the kerfs and splines, then fit the corner pieces together. Square and clamp the door frame while the glue dries...then promptly remove all glue drops and smears.

17: Cut the mortises in the cabinet for the hinges. Cut them just deep enough to allow for the thickness of the hinges. Measure the door and mark the locations of the hinge mortises...then place the door on the cabinet to verify that the locations are correct before cutting the mortises.



18: Clean away any dust and finish the two pieces with the stain and/or top coat of your choice.

19: Install the glass. After the finish has dried properly, lay the door face down on a flat surface...being careful not to scratch or damage it. Use glazing points or 1/4" molding to hold the glass in place.

20: Install the hinges...making sure that they are square to the door and cabinet. If they're not perfectly square, the door won't open and close easily.

21: Install the latching hardware, door handle and any other hardware you have chosen.

Bill of Materials

(finished dimensions in inches)

A Side (2) $3/4 \times 3 \times 25-1/2$

B: Top shelf rail (1) $3/4 \times 3 \times 15$

C: Bottom shelf rail $3/4 \times 2-1/4 \times 15$

D: Top & bottom shelf (2) $3/4 \times 3 \times 15$

E: Door rail (2) $3/4 \times 1-1/2 \times 16-1/2$

F: Door stile (2) $3/4 \times 1-1/2 \times 20$

G: Interior shelf (3) $1/4 \times 2-5/8 \times 15$

H: Dividers (2) $1/4 \times 2-5/8 \times 4$

J: Dividers (3) $1/4 \times 2-5/8 \times 4-3/4$

K: Dividers (3) $1/4 \times 2-5/8 \times 4-1/4$

L: Back panel (1 - plywood) $1/4 \times 15-3/4 \times 19-1/4$

Hardware

M: Glass (1) $1/8 \times 14 \times 17-1/2$

N: Hinges w/ screws (2)

P: Knob (1)

Q: Latch (1)

Brads 1/2 oz

KNICKKNACK CABINET

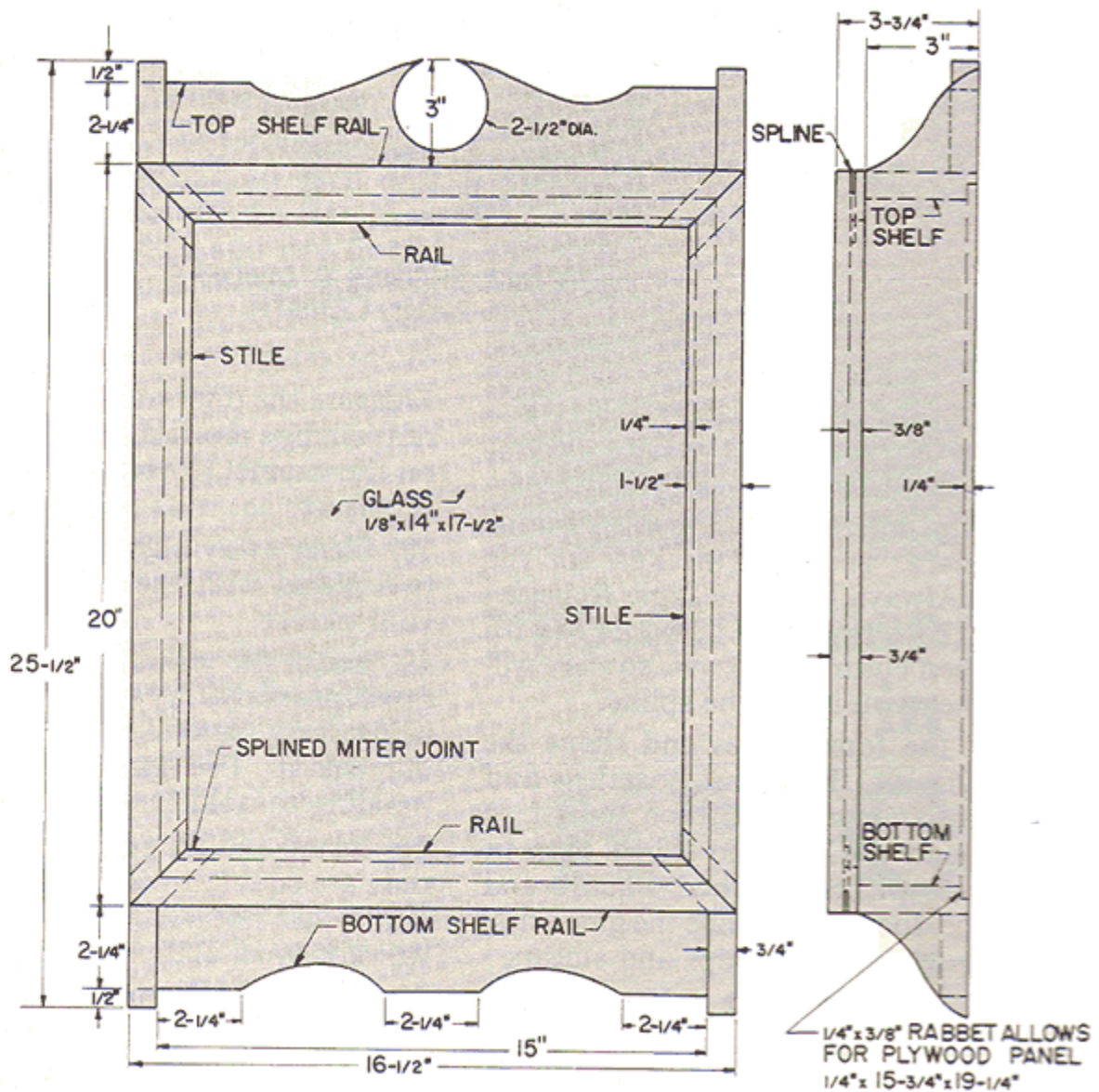

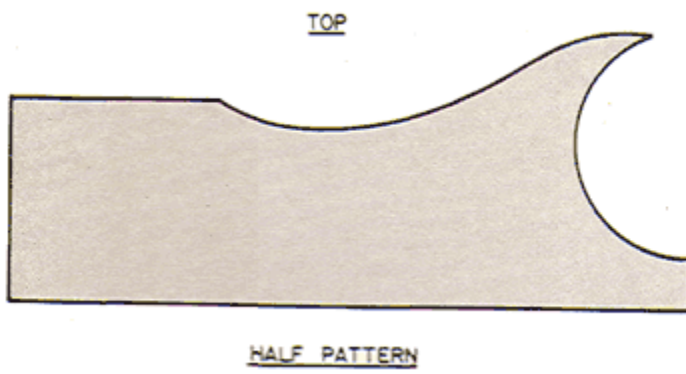

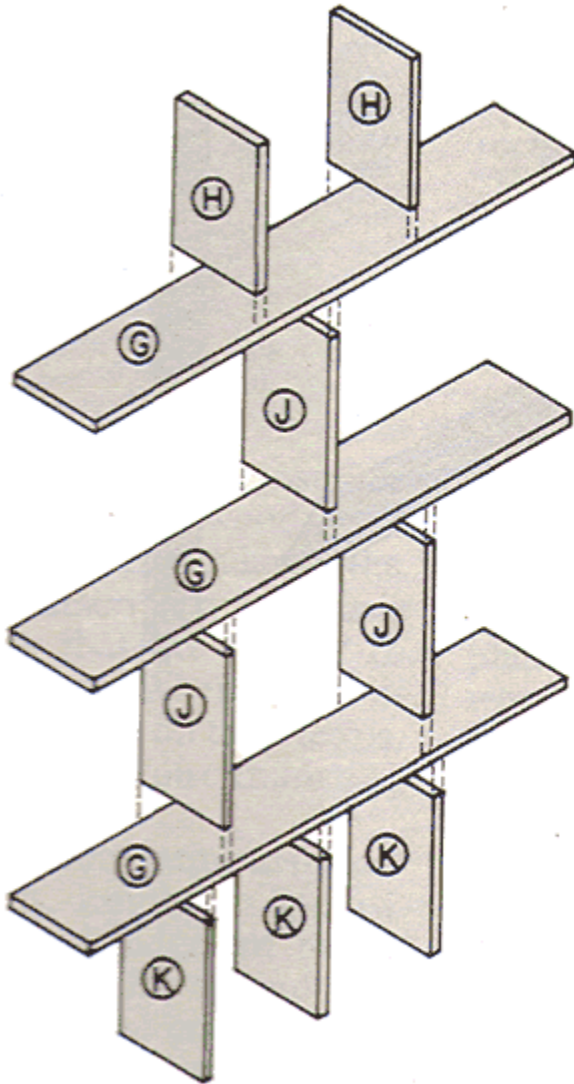

SHELF & DIVIDER ASSEMBLY

SIDE PATTERN

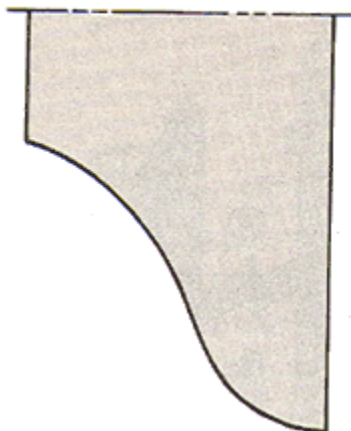

BOTTOM

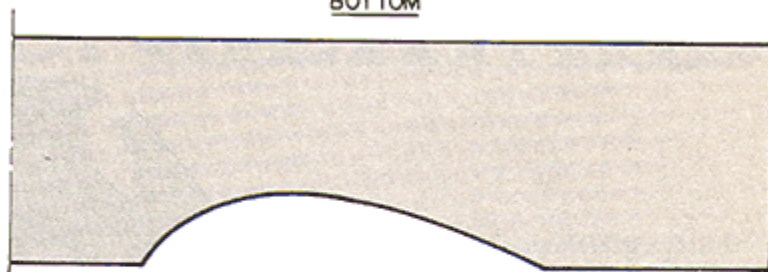

HALF PATTERN

INTERIOR SHELVES

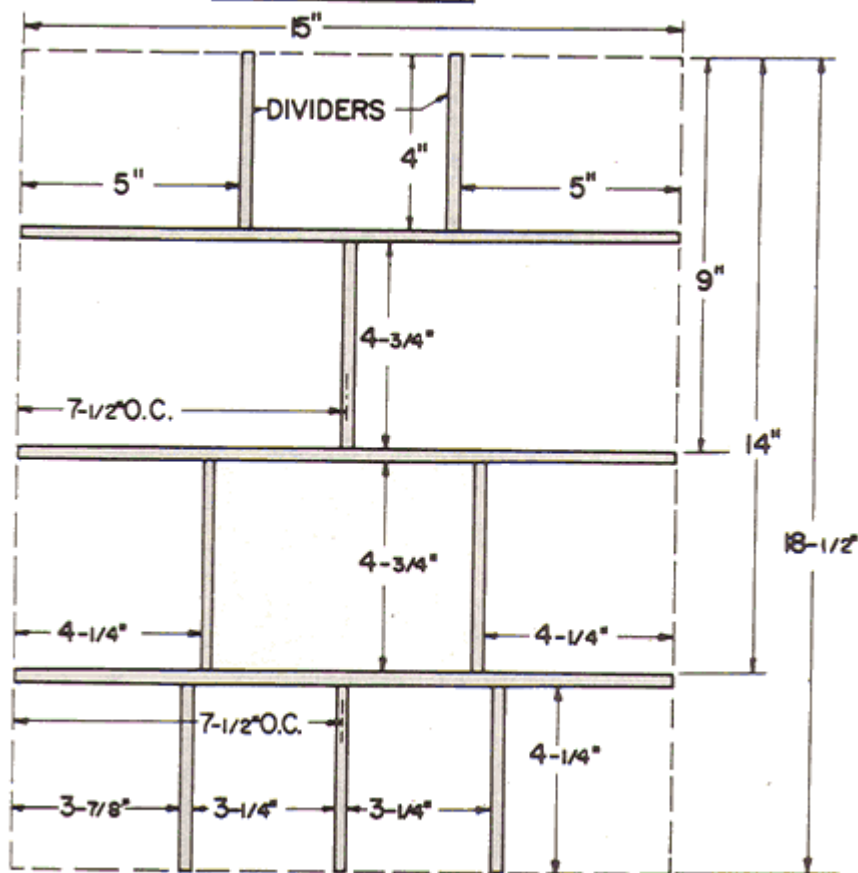

NOTE: ALL SHELVES & DIVIDERS
1/4" x 2-5/8" x LENGTH

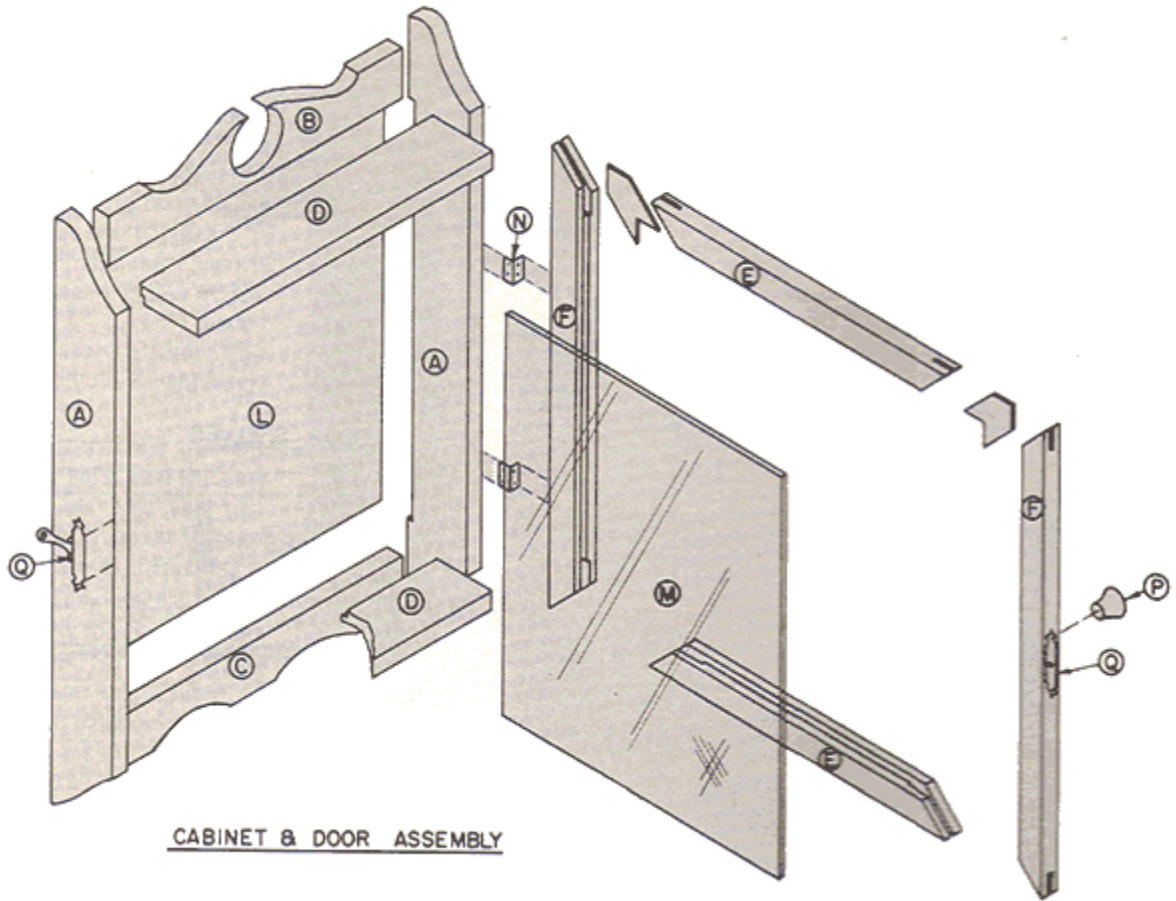

CABINET & DOOR ASSEMBLY

LANTERN HOLDER

Here's an attractive decorator project for adults

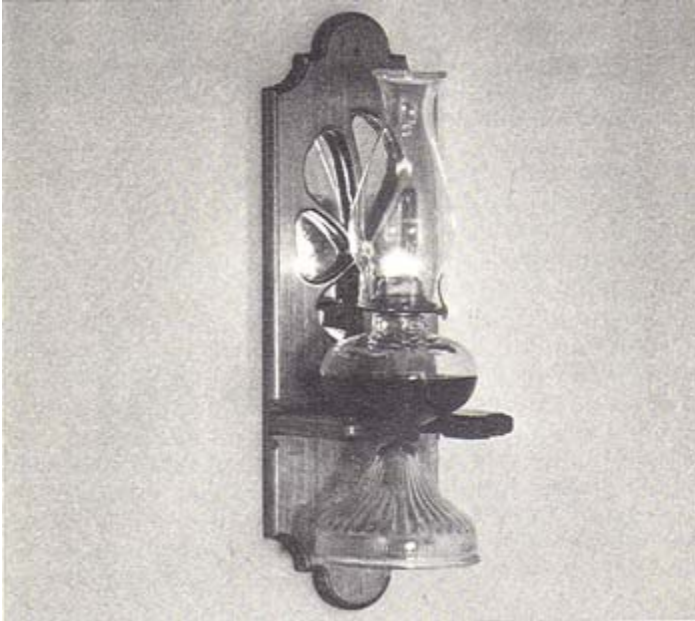

The age-old kerosene or oil-fired Lantern, complete with reflective Lantern Holder still casts a warm, friendly light...even in the most modern hole.

In our example, the notched shelf on our Holder is designed to cradle the Lantern, while the mirror behind reflects interesting patterns of light throughout the room.

There are two ways to go about making this Holder:

- If you're just making a few to give as gifts, the Scroll Saw or Sabre Saw method is probably going to be the best approach for you.
- However, if you're planning to make a larger quantity that you'll be selling at craft fairs and such, a router-based duplicating device such as Shopsmith's Overarm Pin Router will make fast, easy work of duplicating high numbers with amazing repeatability.

We'll give you the basic procedures for both methods...but it's important to note that actual sizes and designs are really up to you...and must be based on the actual Lantern you plan to use with it.

For example, you could create a completely different design for behind the mirror – or use a solid back with no mirror. You could substitute stained glass



for the mirror, and perhaps even make a solid shelf to hold candles or potted plants instead of the Lantern. So take a look at and understand our approach...then make the Holder to fit the Lantern you plan to put with it...and the mirror cutout shape you feel will best suit the décor.

The Scroll Saw Approach:

1): Glue-up (if necessary) and cut the pieces for the Lantern Holder Back and Shelf to outside dimensions. Make your workpieces about 1/2" larger all-around to allow for final shaping.

2): Cut the dado to accept the shelf

3): Enlarge the pattern in our drawing (or create your own), then transfer to your workpieces for cutting the outside shape and the mirror cut-outs. If you're using a Scroll Saw, you can probably pad-saw the Shelves and Backs two at a time by temporarily attaching your pairs together with Double-Stick Tape .

4): Use a hand-held Router or your Shoppersmith Routing Package to rout a 1/8" to 3/16" deep area behind the mirror cut-out area for mirror to drop into.

5): Next, use your Drum Sander set-up to smooth all internal and external edges to your pattern lines.

6): Once all edges are sanded, use a 3/8" piloted Round-Over Bit to form the decorative edges. Note that the edges of the Mirror cut-out are rounded-over flush, while the outer edges are made with a deeper cut to leave an extra decorative ridge. NOTE: Be careful to not shape the outside areas of the Back or Shelf where the two pieces glue together (See drawing).

7): Glue the Shelf to the Back and reinforce the joint with #12 x 1-1/2" wood screws.

8): Apply the finish of your choice.

9): Attach the mirror



The Pin Routing Approach:

1): Glue-up (if necessary) and cut the pieces for the Lantern Holder Back and Shelf to outside dimensions. Make your workpieces about 1/4" larger all-around to allow for final shaping.

2): Cut the dado to accept the shelf

3): Enlarge the pattern in our drawing (or create your own), then use it to make your pin routing fixture, following the process described in your Overarm Pin Router Owner's Manual.

4): Attach your workpieces to the fixture(s) and use a Straight Router Bit to cut out all internal and external shapes. Again, your Overarm Router Manual describes this process in detail.

NOTE: If you'll be forming decorative internal and/or external edges on your Holder (as we've done), the straight bit you use to create your fixture grooves and then cut out the basic shapes must be as large or larger in diameter than the outside diameter of the bearing pilot on the router bit you'll use for decorative edging. If not, some radii may be too small to accommodate the pilot on your edging bit.

5): Remove the workpiece from the fixture and flip it over, top-down on your Router Arm Table surface. Mark off a rectangular area on the back side of the stock that's 1/4" or so larger all the way around than the area of the pattern that will be in front of the mirror. Use your Router Arm's Fence as a guide and rout out a 3/16" deep recess that you'll drop the mirror into.

6): Switch to a 3/8" piloted Round-Over Bit to form the decorative edges.
NOTE: The edges of the Mirror cut-out are rounded-over flush, while the outer edges are made with a deeper cut to leave an extra decorative ridge.
NOTE: Be careful to not shape the outside areas of the Back or Shelf where the two pieces glue together (See drawing).

7): Next, use your Drum Sander set-up to smooth any internal or external edges, if required.

8): Glue the Shelf to the Back and reinforce the joint with #12 x 1-1/2" wood screws.

9): Apply the finish of your choice.

10): Attach the mirror

Assembly:

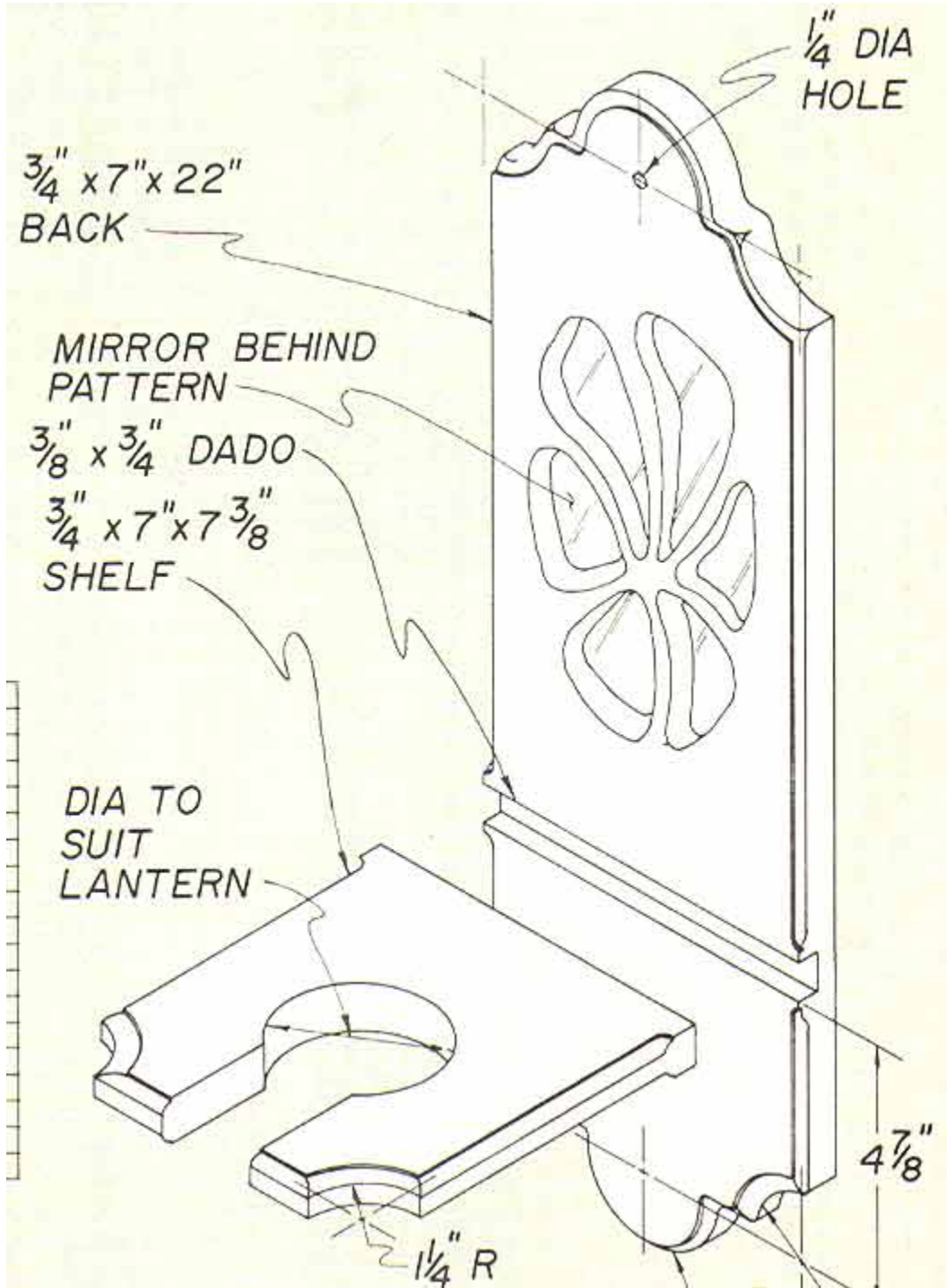

Base and Back Detail:

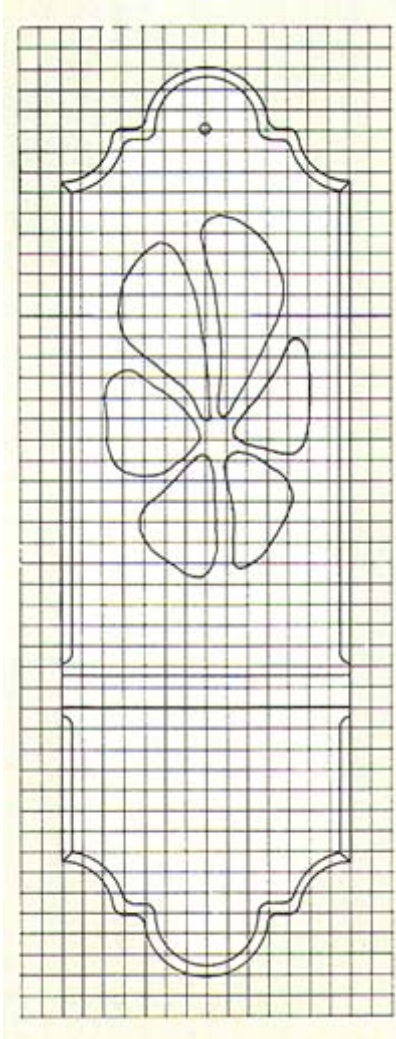

Holder Detail:

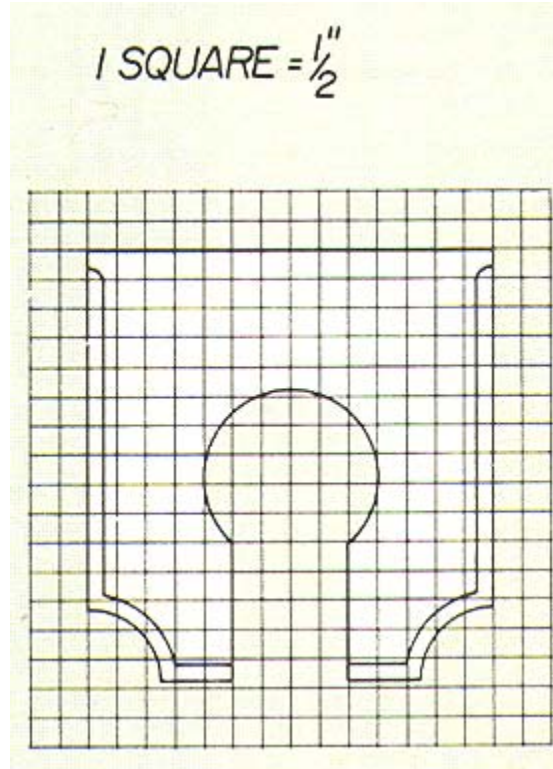

NESTING TABLES -2

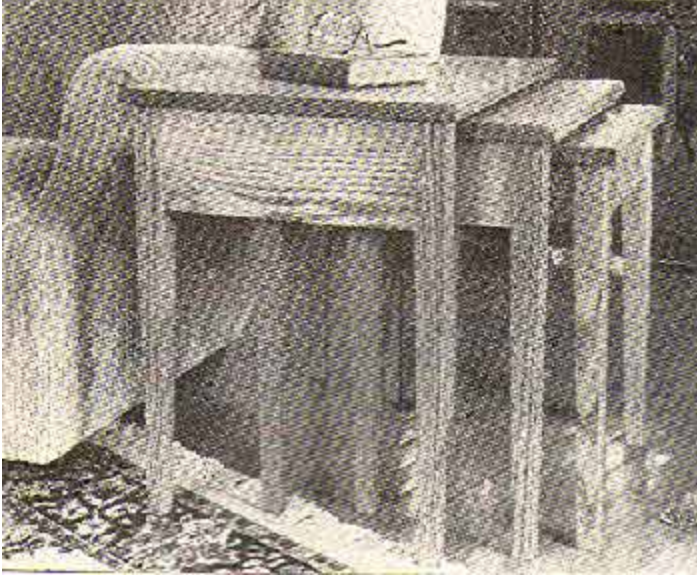

This simple project that will take you less time to build than you might imagine at first glance.

Why? Two reasons. First, there's no trick joinery, here...just simple dowelled butt joints. and second, because of their unique design, you can "borrow" machine set-ups from table to the next. For example: 1) The legs use the same Joints tapering set-up. 2) Although the widths of the Table Rails vary, the dowel hole boring set-ups are pretty much the same.

We built our examples using red oak, but you can make yours with any wood that best suits your décor. Just remember that since the legs are to be tapered, they should be made from clear, straight-grained wood for the best results. So, let's get started

1: Cut and assemble the stock for the three Table Tops (C). Make them about 1/2" oversized all the way around so you can square them up properly once the glue has dried. Be sure to pay close attention to the grain of the wood as you assemble the pieces for your Tops.

It's also important that all pieces are made from stock of the same thickness...and that everything is held flat and true as the glue sets up. A set of Double Bar Clamps will be a big help, here. They're real time-savers, since they'll squeeze the boards together and hold them flat at the same time while the glue dries.



Cut the Table Tops to final size, being sure everything is square.

2: Cut the Legs (D) to size, being certain they are square, all the way around. You'll note that all Legs are made from 1-1/2" square stock in differing lengths. Leave them un-tapered for now.

3: Cut the Rails (A) to size...again, being certain they are square, all the way around.

4: Set up for horizontal boring, then bore the holes for the dowels in the Rail ends. Use your Miter Gauge to hold your stock so the holes are perpendicular to the Rail ends...and your Rip Fence as a stop to keep the Rails from moving during the boring process. While you're still in horizontal mode, bore the Top stabilizing dowel holes in the tops of the Legs.

5: Change to vertical Drill Press mode and bore the mating dowel holes in two adjacent sides of each Leg top, as shown in the Table Assembly drawing. Next, drill the mating stabilizer dowel holes in the undersides of the Table Tops.

6: Set up your Jointer to make a 7/64" deep cut. Use a stop block at your starting position for each Leg and make two passes on all four sides of each Leg, as shown in Fig. 1. You'll make the taper the same length on all 12 Legs. Once the tapers are formed, re-set your Jointer to make a 1/32" deep cut and make one final pass over the Jointer on only the tapered sides of each Leg.

Set your Jointer fence to a 45-degree angle and cut a slight chamfer on all four Table Top edges. Be sure to chamfer only the tops of the Table edges (See Fig. 2).

7: Use your Table Saw to cut the grooves on the inside of each Rail. These grooves will accept the retainer clips that will be used to hold the Table Tops firmly down onto the base assemblies, allowing the Tops to move with changes in the weather.

8: Assemble all three Table Bases and finish sand them. Apply the finish of your choice. Then attach the Tops with retainer clips and stabilizer dowels (no glue on stabilizer dowels).



Bill of Materials

(finished dimensions in inches)

	LARGE TABLE	MEDIUM TABLE	SMALL TABLE
Short Rail (A)	(2) 3/4 x 5-1/4 x 13	3/4 x 4-1/8 x 11-1/2	3/4 x 3 x 10
Long Rail (B)	(2) 3/4 x 5-1/4 x 21-1/2	3/4 x 4-1/8 x 17	3/4 x 3 x 12-1/2
Top (C)	(1) 3/4 x 17 x 25-1/2	3/4 x 15-1/2 x 21	3/4 x 14 x 16-1/2
Legs (D)	(4) 1-1/2 x 1-1/2 x 21-1/4	1-1/2 x 1-1/2 x 20-1/8	1-1/2 x 1-1/2 x 19

Miscellaneous:

(44) 5/16" dia. x 1-1/2" dowels

(20) Mirror retaining clips

(20) #6 x 1/2" Roundhead wood screws

Top Detail:

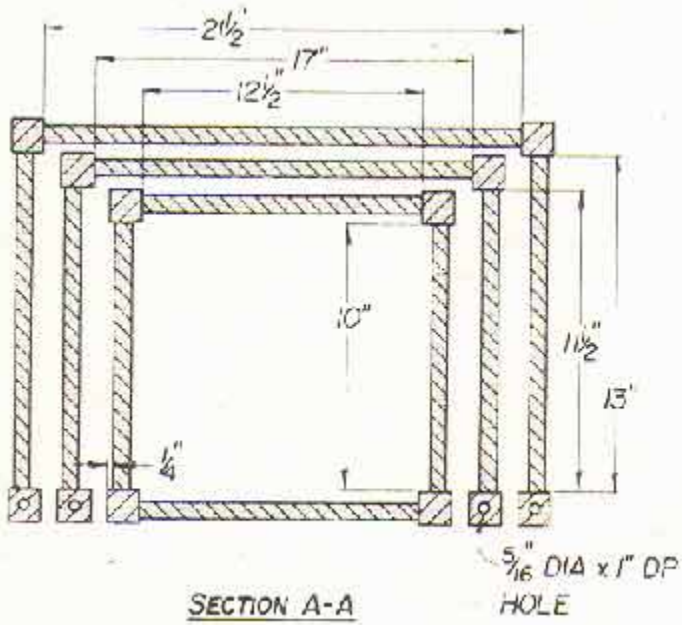

Detail A:

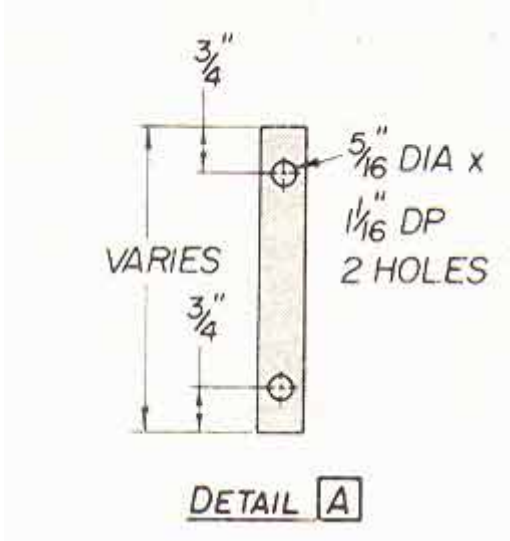

THE ORNAMENTAL HOLIDAY HURRICANE LAMP



Make just one of these great lamps in a single afternoon - or make a bunch more over a two-day weekend that you can give as gifts for family and friends!

With some projects...due to the ways they're designed...it's often about as easy to make 12 of them as it is to make only one. This Lamp is a prime example of that. Since it's comprised of just two different-shaped pieces of wood (the Sides and the Bottom), once you've established your Table Saw set-ups to rip or crosscut one of the eight side pieces to size, cutting another 16 or so is a simple matter of pushing more wood past the blade.

And, if you add yet another time-saving technique -- re-sawing multiple, pre-cut thin pieces from a single thick piece of stock - you'll be able to save even more time!

It's always a good idea to keep this in mind with many simple projects. Our lives are filled with birthday, anniversary and holiday opportunities to give our friends and families projects that we've made with our own two hands - and it can often be as easy as making a couple of set-ups...then simply pushing a few more pieces of wood past the blade!

MAKE IT YOURS!

Although our example Lamp is octagonal and features a holly, Christmas tree and bell design, it could just as easily be square or hexagonal...and feature a



Santa Claus, reindeer and snowman design. Or...you could make a number of copies of each design. It's your choice.

Option: If you prefer, you can also make a four, five or six-sided Lamp. Here are the table tilts for each: 4-sides 45 degrees - 5-sides 36-degrees - 6-sides 30-degrees.

If you're making anything other than our 8-sided version, don't forget to alter the shape of your Bottom (B) piece, accordingly.)

Our example also features a 9-1/2" glass chimney inside to protect the wood from exposed flames.

So, MAKE IT YOURS!...just a few simple changes can often make a big difference!!

SAVE TIME WHEN MAKING MULTIPLES - Here are two different ways for you to cut your building time when making more than one of these lamps:

#1: Pad-Sawing -- Purchase 1/4" thick stock, then use Double-Stick Tape to temporarily tape a number of pieces together (up to 2" worth for Scroll Sawing) and do the cut-outs for the entire stack at once. When finished, just un-tape and you'll have four pieces.

#2: Resawing -- If you have a Bandsaw, you can first Scroll Saw the designs into thick stock, then re-saw them and plane or joint them to final thickness. After making your cut-outs, re-saw your stock into 5/16" thick pieces, then use your Thickness Planer or Jointer to plane the pieces down to their final 1/4" thickness. Due to the kerf left by most re-sawing blades, you'll be able to get two pieces from standard 4/4 hardwood, three pieces from 5/4 and four pieces from 8/4.

So, let's get started....

1: Cut all stock to the indicated widths and lengths, as described in the Bill of Materials.

2: Print out and photocopy your pattern to size, according to the drawings (or develop your own designs).

3: With your MARK V in Table Saw Mode, tilt your table to 22-1/2 degrees, position your Rip Fence to the RIGHT of the blade and cut out your eight Side (A) Pieces.

4: Transfer the full-size pattern to the outsides of the Side (A) pieces you just cut. If you'll be using the *Pad-Sawing* or the *Resawing* method, you need



only apply the pattern to the top of each stack -- or to the top of each piece of thicker 4/4, 5/4 or 8/4 stock..

5: Drill a 5/16" dia. hole in the center of each cutout area for blade insertion. NOTE: 5/16" happens to be the correct size for the Holly "stems". Use any size drill you like.

6: Use your Scroll Saw to cut out your designs.

7: Once you've made your cut-outs...

Individual or Pad-Sawing Method: Separate individual Side pieces and sand all surfaces and edges smooth. IMPORTANT: Be careful NOT to sand the beveled edges, as doing so could alter their angles - and your pieces will not fit together properly. Lay your pieces aside for now.

Resawing Method: Use your Bandsaw with a special Resawing Blade to cut your thick stock into 5/16" slices. Use your Jointer or Thickness Planer to remove 1/32" from each side of the slices. Lay your pieces aside for now.

8: Lay out your octagonal Bottom (B). Use your MARK V Table Saw with your Miter Gauge set at a 45-degree angle to cut out the Octagonal shape. Be sure to use the Safety Grip on the Gauge and a wooden Extension Face to maintain adequate control of your workpiece while making this cut.

9: Use your Bandsaw to cut out four Glue Blocks (C) 1/4" x 1/4" x 3-3/4" long.

10: Lay your cut-out Side pieces (A) -- side-by-side on a flat surface - with their beveled edges just touching one another and facing down. Carefully place two pieces of masking tape at each joint.

11: Carefully turn this taped-together Assembly over onto your flat surface - with the beveled edges now facing up.

12: Run a small bead of woodworker's glue along each joint - and around the edges of the octagonal bottom

13: Carefully roll the Lamp Assembly up to form an octagonal shape and secure it together (loosely for now) with some large rubber bands, a strap clamp or a piece of rope with a wooden tourniquet-style tightening handle.

14: Gently press the octagonal Bottom (B) into the Lamp Assembly until just 1/4" of the bottom is protruding below the sides. Wipe off any excess glue around the Bottom.



15: Tighten your clamping devices around the sides...check for squareness...and wipe off any glue squeeze-out with a damp cloth.

16: Apply glue to...and position...the four Glue Blocks (C) inside the opposing sides (A) of the assembled Lamp, where they meet the Bottom (B)...to serve as reinforcements. Set aside to dry.

17: Once the glue has dried thoroughly, remove your clamping devices and finish-sand.

18: Apply the finish of your choice to the outside.

19: Paint the inside white or silver...or cover your cutouts with various colors of cellophane.

20: Install your candle and glass chimney, light and enjoy!

LIST OF MATERIALS –

(finished dimensions in inches)

A	Sides (8)	1/4 x 4 x 11-1/2
B	Bottom (1)	3/4 x 9 x 9 (octagonal)
C	Glue Blocks (4)	1/4 x 1/4 x 3-3/4
Glass Chimney (9-1/2")		

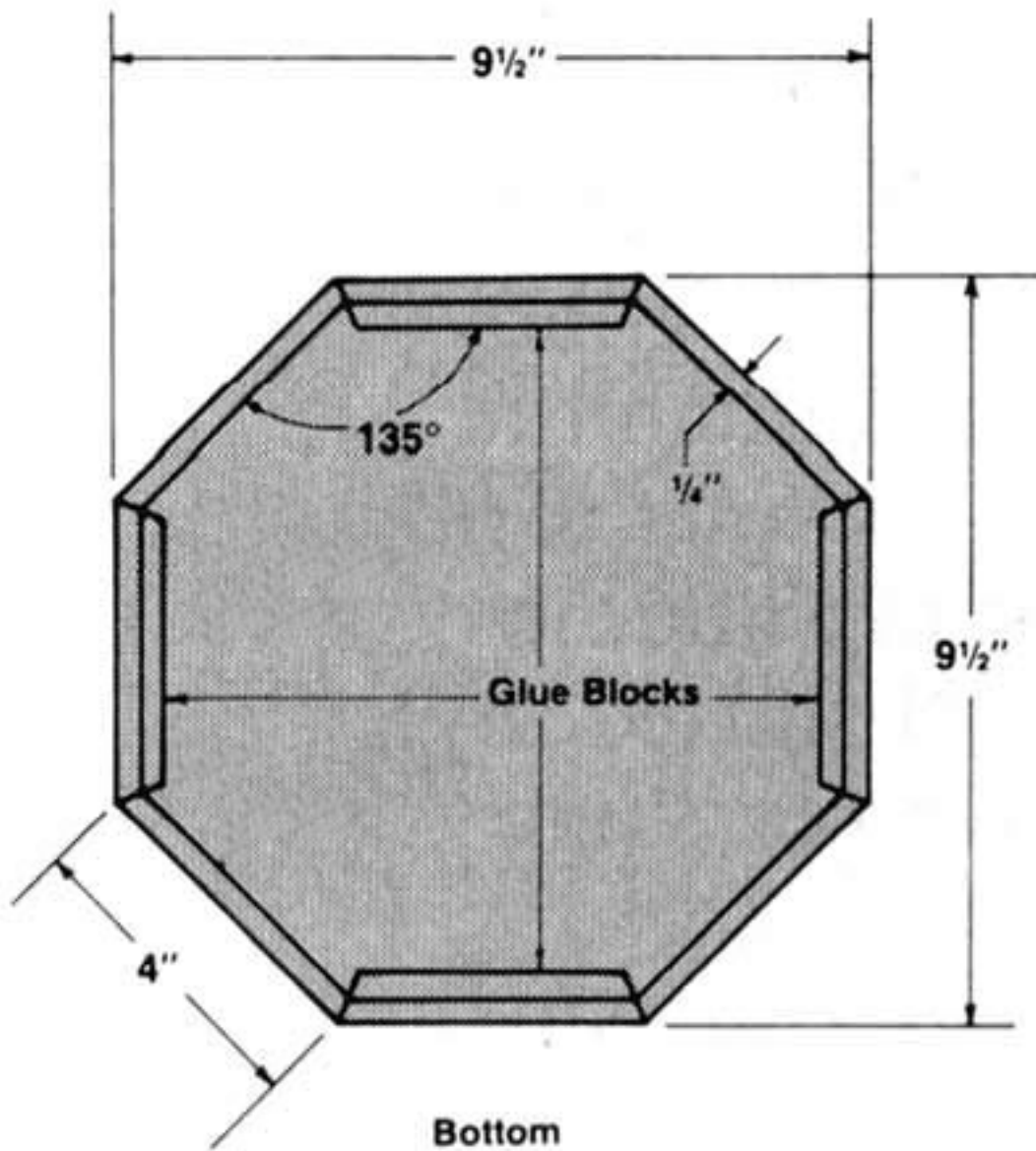

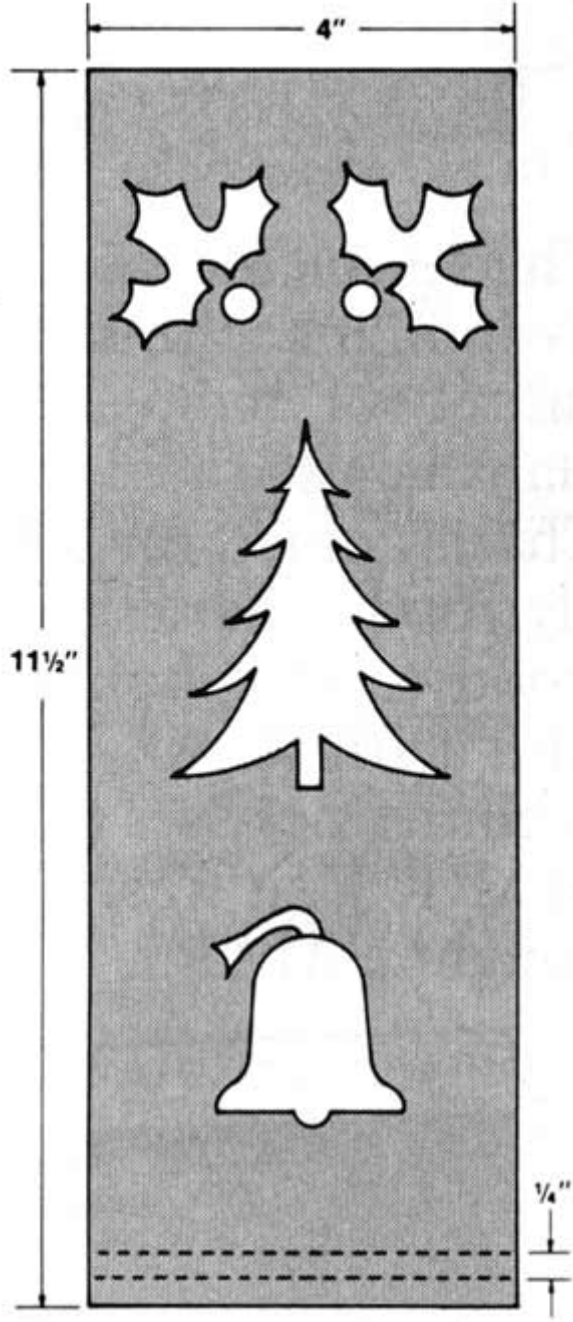

OVAL PICTURE FRAME



An oval frame can greatly enhance the photo, painting or mirror it frames. However, keeping all the dimensions correct can sometimes tax even the most skilled woodworker. **(Figure A)** below will help you make that frame fit what you want to put in it.

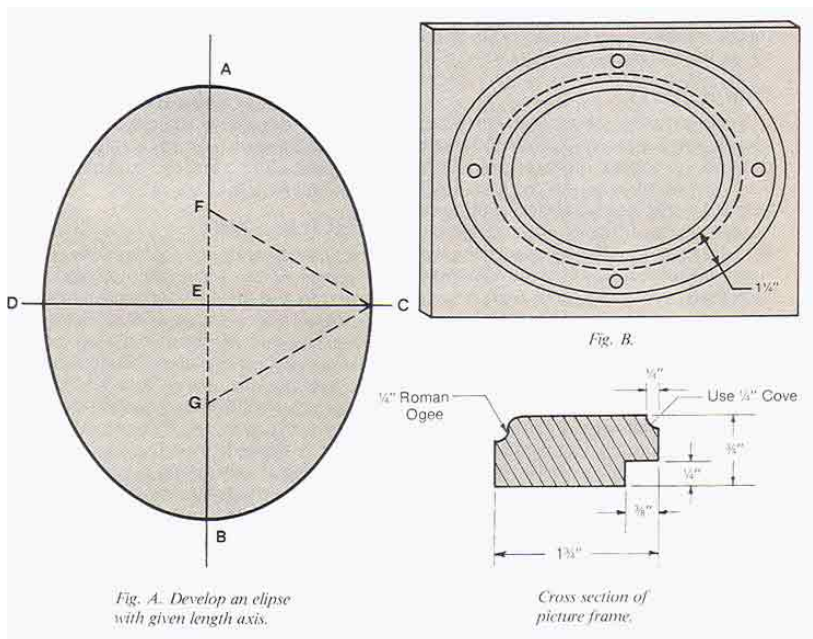

First, measure the width and height of the item you're planning to frame (these dimensions the length of the two axes in your oval).



On a piece of heavy paper, establish the axes of the desired lengths (In Fig A., these are represented by lines AB and CD). Draw these lines so the midpoint of each crosses at point E.

To find points G and H, swing an arc the length of AE from points C and D. Where these arcs cross line AB, points G & H will be found. Place straight pins or push pins at points C, F and G.

Tie string or thread around points C, F and G. Place the tip of a pencil at point C and remove that pin. Keep the string tight and move the pencil from C to B and part of your oval will appear. Follow around the other points to complete oval #2 (See Fig. B).

Now, you can develop your frame by drawing concentric ovals around new points 1/2" inside and 1-1/4" outside the original points AE.

No matter which method you plan to use in constructing these frames, if you're careful, when you're through cutting everything out, you'll have a square frame with an oval light (or cut-out), an oval frame with an oval light and an oval decoupage plaque.

Making The Frame

Overarm Pin Router Method

1: Place the oval pattern on a piece of 3/8" thick plywood and trace to make your routing template.

2: Use your Bandsaw or Scroll Saw to cut out this oval disc...then your Disc Sander or Drum Sander to sand your template edges smooth.

NOTE: This template can then either be screwed directly to your stock if you're making just a couple of frames or mounted to a piece of 3/4" thick plastic laminate-covered particleboard (sink cut-out) to make a fixture for mass-producing high quantities of these frames.

3: Attach the template to a piece of 3/4" particleboard (or stock) with two countersunk #8 x 1" flathead wood screws positioned near points C and D.

4: Using the Shopsmith Overarm Pin Router with a 1/4" straight bit and a 3/8" Guide Pin, trace around the outer edge of the template as you cut 3/8" deep grooves in the laminate side of the fixture blank. NOTE: This is done with progressive cuts advancing the depth 1/8" with each successive pass.

5: Using the same screw holes and #8 x 1" screws, attach the particleboard



master to your frame stock (we used red oak 14" x 11" x 1"). Be sure to countersink all screws to a depth of 1/4" to keep them from catching and dragging on your worktable surface.

6: Repeat step 4, but cut out the oval profile in the frame stock and remove the frame from the fixture.

7: Using the Overarm Router with the starter pin and a 5/32" bearing-piloted Ogee bit , form the decorative outer edge in two progressive cuts.

8: For the internal decorative cove, use a piloted 1/4" Cove bit and starter pin in a similar manner to step #7, above. For the back rabbet, use a 3/8" bearing-piloted Rabbeting bit . Be sure you're always cutting against the rotation of the bit, as climb-cutting can be dangerous.

9: Sand and apply the finish of your choice.

Scroll Saw Method

1: Place the oval pattern on your frame stock and trace.

2: Use your Scroll Saw to make the external and internal cuts for your frame...then your Disc Sander or Drum Sander to sand your edges smooth.

3: Using a hand-held Router or your MARK V Router Package with the starter pin and a 5/32" bearing-piloted Ogee bit , form the decorative outer edge in two progressive cuts.

4: For the internal decorative cove, use a piloted 1/4" Cove bit and starter pin in a similar manner to step #3, above. For the back rabbet, use a 3/8" bearing-piloted Rabbeting bit . Be sure you're always cutting against the rotation of the bit, as climb-cutting can be dangerous.

9: Sand and apply the finish of your choice.

PICNIC TABLE-8

You should be able to complete and start using this simple picnic table in record time! One day to build it -- and another to enjoy it!

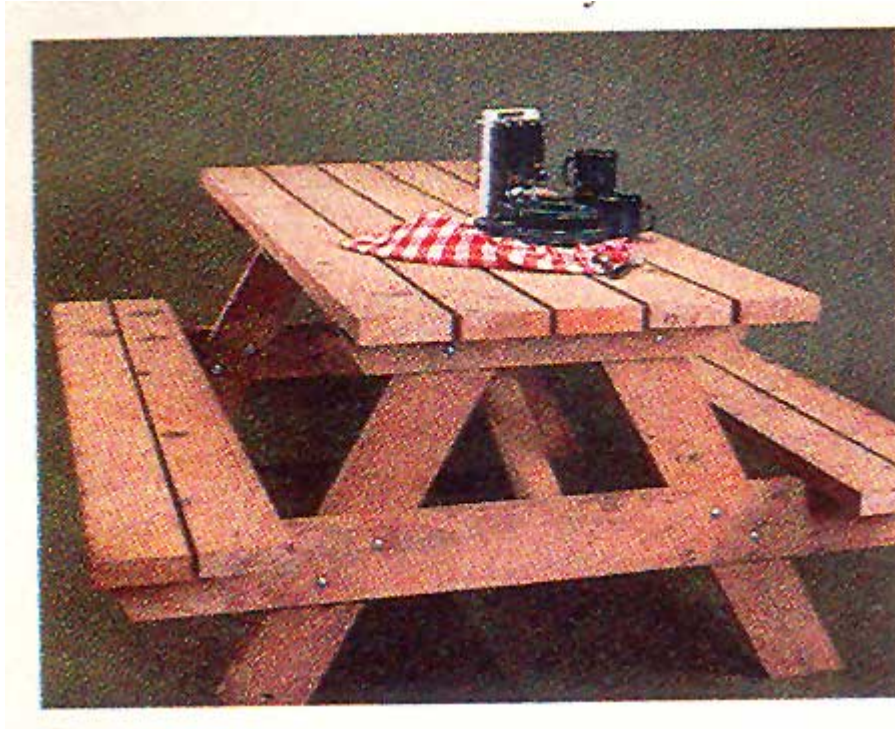

1: Crosscut parts A,B,C and F to length (*see CUTOUT DIAGRAM*). If you're using a MARK V or table saw, set your Miter Gauge at 90o and use an extension table or similar outboard device to support your stock. You could also use a hand-held circular saw for making all crosscuts, if you like.

Cutout Diagram

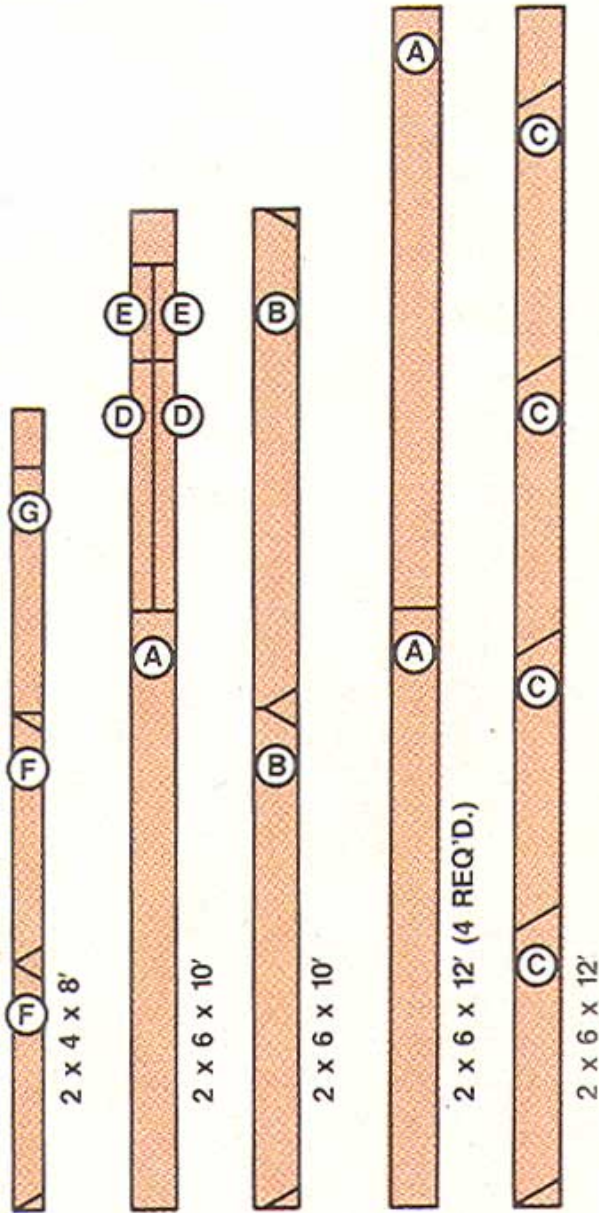

Use your MARK V or table saw to rip one five-foot-long 2" x 10" in half...then crosscut parts D and E to length.

2: Bevel the ends of parts E and G by setting your MARK V or table saw's worktable or arbor at 90o...angling your Miter Gauge to 30o...and placing the faces of pieces E and G against your Miter Gauge face, with the work piece edges resting on the table surface while you make your end bevel cuts.

3: Cut the miters on the ends of parts B, C and F by setting your MARK V or table saw's worktable or arbor at 90o...angling your Miter Gauge to 30o... and placing the faces of pieces B, C and F against your worktable surface, with the work piece edges resting against your Miter Gauge face while you make your end miter cuts.

4: Assemble parts B, C and F with 5/16" x 3-1/2"l. carriage bolts. Use two bolts per joint. Use #12 x 2-1/2" flathead wood screws to attach the top and seats (A) to the assembled frame. The seat and top supports (E and G) are also attached with #12 x 2-1/2" wood screws.

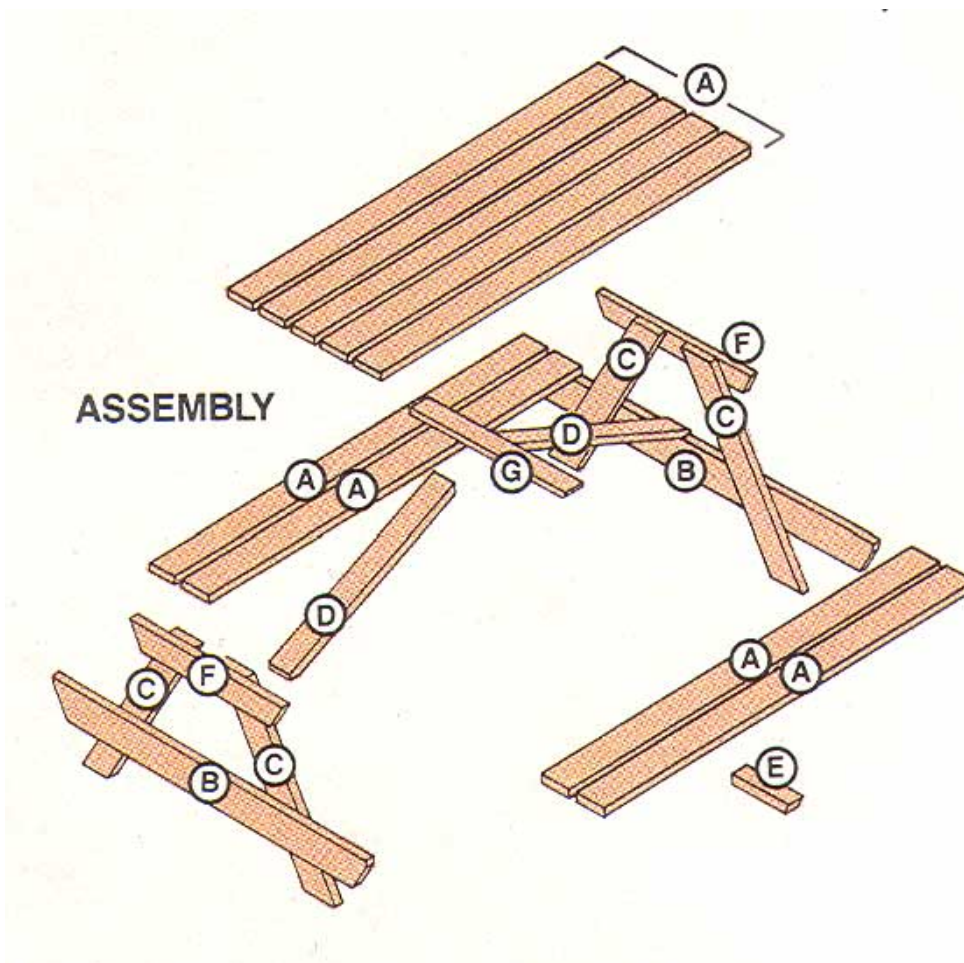

5: Cut the braces (D) to fit. With your stock resting on edge, tilt your Miter Gauge to 25° and bevel one end of each brace. Hold the upper ends of the braces in place against the center top support (G) while you mark the lower brace ends for length. Set your Miter Gauge at 67° and cut the marked end bevels.

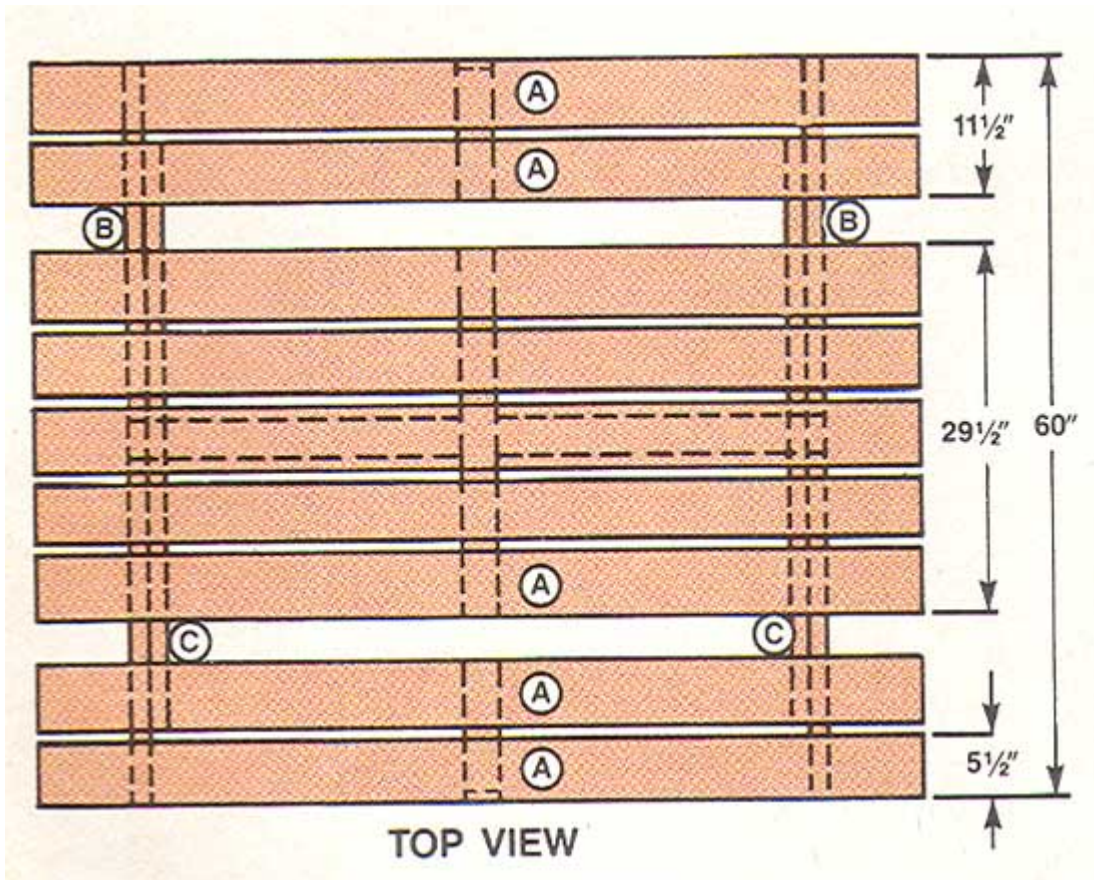
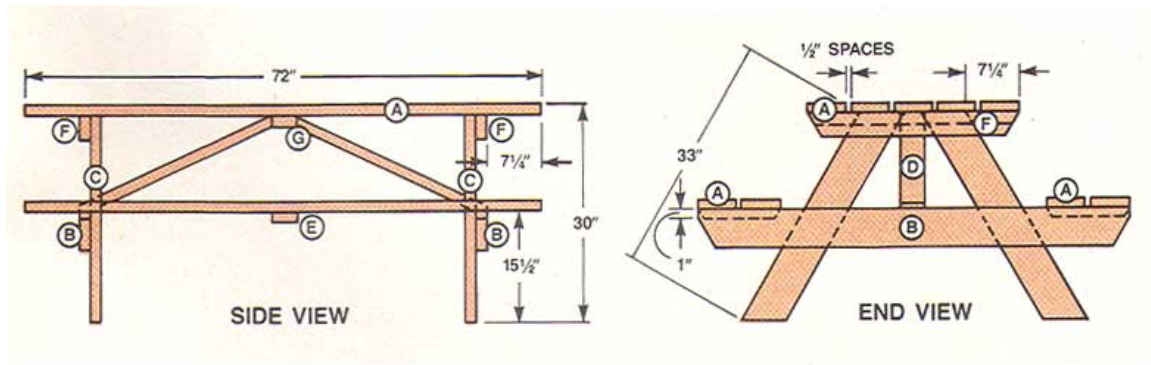



6: Finish. Apply the outdoor finish of your choice and enjoy.

Bill of Materials

(finished dimensions in inches*)

Item	Description	Qty	Measurements
A	Top and Seats	9	2 X 6 X 72
B	Seat supports	2	2 x 6 x 60
C	Legs	4	2 x 6 x 36
D	Braces	2	2 x 3 x 30
E	Center seat supports	2	2 x 3 x 11-1/2
F	Tabletop supports	2	2 x 4 x 29-1/2
G	Center top support	1	2 x 4 x 29-1/2

#12 x 2-1/2" stainless or cad plated flathead wood screws (60)

5/16" x 3-1/2" stainless or cad-plated carriage bolts (16)

* Standard lumberyard dimensions

THE POOR MAN'S HALL BUTLER



Have you ever noticed how jackets, coats, scarves, hats, mittens and other "outerwear" always manage to find their ways into unsightly piles on top of every piece of furniture near your home's entryway? If this sounds like your house, Bunky...if you can't see the furniture for the clothing...perhaps you need Jeeves, here...The Poor Man's Hall Butler! And although he won't smile at you, vocally call you by your name, bid you a fond "adieu" or welcome you home...he will help you keep your "stuff" in order and dress-up that barren wall next to the front door.

MAKE IT YOURS!

The Poor Man's Hall Butler can easily be altered from the "Traditional" design shown in our plan...to another of your choosing.

1. Start by cutting the Panels (G, H, J) and Shelf (M) from a single sheet of 3/4" plywood.

TIP: We used a carbide-tipped saw blade for this job, since a fine-toothed plywood blade could easily heat up and possibly wobble and burn when making such a long cut in thick stock.

CAUTION: It's always best to enlist the assistance of a helper when cutting large sheets of stock. If a helper is not available, use extreme caution and support both halves of your stock with auxiliary support devices such as Roller Stands and/or outboard Support Tables.

2. Use a hand-held sabre saw to cut the mirror opening in the Back Panel (G). We chose to cut a simple oval, 22-1/2" wide by 34-1/2" tall. However, you can make the opening any size or shape you like.

Drawing the oval

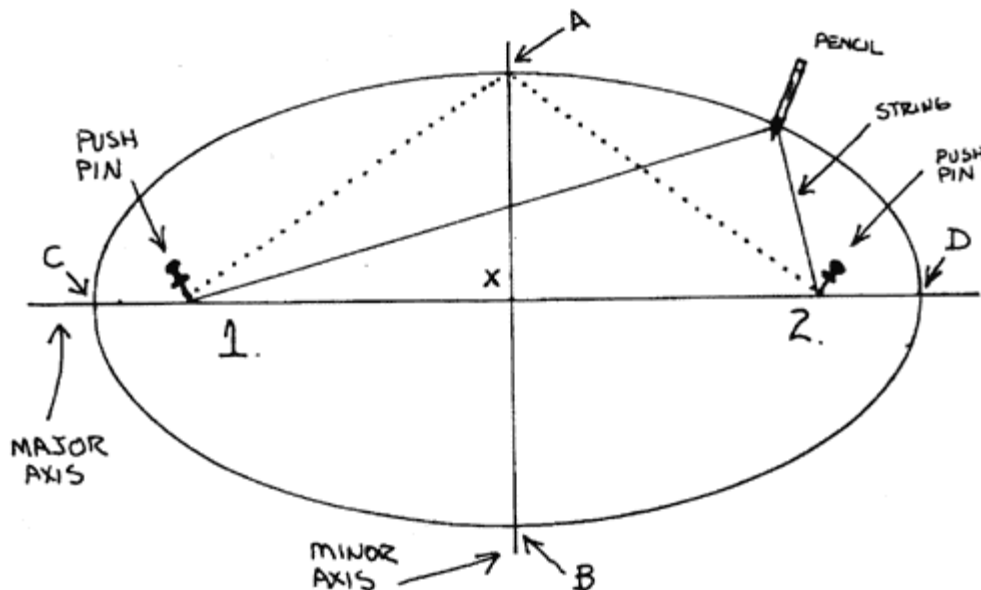

Turn your Back Panel (G) over and draw your oval layout on the back side. Begin by drawing perpendicular horizontal and vertical centerlines for your oval as shown in Fig. 1. These lines will be your minor (A/B) and major (C/D) axes.

Set a large compass to the distance CX (in our case, this should be half the width of our mirror opening or 11-1/4"). Position the compass point at location A and strike an arc across the major axis line at points #1 and #2.



Take a long piece of string or heavy thread and tie it into a continuous loop that will be equal to the distance between points "C" and "2", when the loop is pulled taut (In other words, if your push pins were inside your tied loop at points "C" and "2", the loop would be taut.)

Drive your two push pins lightly into the back side of the Back Panel at points #1 and #2 on your layout. Slip your tied loop over the outside of your push pins. Position the point of a pencil or marker inside your string loop at location "A" and begin moving your pencil or marker point around the layout in a clockwise manner...dragging the string loop with you as you finish drawing your oval.

3. Use your Bandsaw to cut the Lid out of the Seat (K).

4. The joinery for this project is a "snap" - most of it consisting of simple butt joints and rabbets, all reinforced with wood glue and countersunk wood screws. The one difficult joint - a stop rabbet in the Front Stiles (B) - is made by carefully lowering your stock onto the Dado Blade and cutting the rabbet to a pre-determined mark on your saw's worktable surface. CAUTION: Always use Push Blocks when performing this operation to keep your hands out of harm's way. Make several passes, taking a little more stock off with each pass. Square the ends of your stop rabbets with a bench chisel.

5. Use a 1" Forstner Bit or Brad Point Bit to drill the holes for the turned Pegs (Q, R) in the Back Stiles (A). Assemble the Back Stiles (A) to the Back Panel (G), build the Storage Box and attach the Seat/Lid (K) to the assembled Storage Box.

6. Screw the Front Stiles (B) to the assembled Storage Box, then dowel the Arms (C) to both sets of Stiles (A, B). Add the Shelf (M), Trim pieces (P, T) and Rails (E, F).

7. Cover the inside edge of your Mirror opening with matching veneer tape (available at your local Home Center). Turn the Pegs (Q, R) and glue them into the Back Stiles (A).

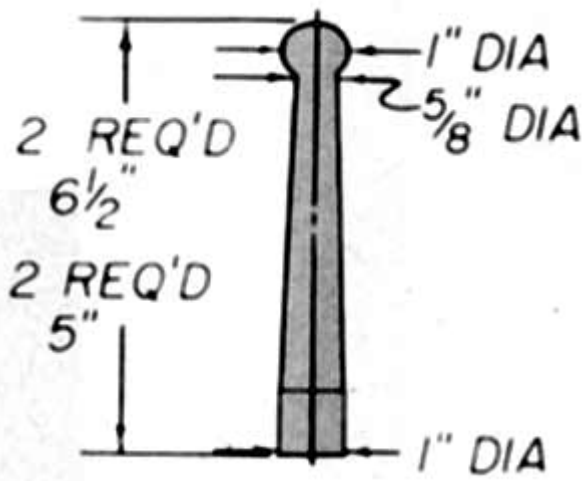

8. If you choose to build this project from standard fir plywood, be sure to apply a light coat of "plywood sealer" to help even-out your stain finish. Be sure to finish with something that won't be affected by wet raincoats. We recommend polyurethanes or spar varnishes.

9. Attach your mirror to the Back (G) using screws and nylon washers.

10. Collect all your coats, jackets and other clothing off the furniture and cover your new "Poor Man's Butler" with them.



LIST OF MATERIALS –

(finished dimensions in inches)

A	Back Stiles (2)	1-1/2 x 1-1/2 x 84
B	Front Stiles (2)	1-1/2 x 1-1/2 x 23-1/2
C	Arms (2)	1-1/2 x 1-1/2 x 17-1/4
D	Seat Brace	1-1/2 x 1-1/2 x 27
E	Front & Back Rails (5)	3/4 x 1-1/2 x 27
F	Side Rails (2)	3/4 x 1-1/2 x 15
G	Back Panel	3/4 x 28-1/2 x 77
H	Front Panel	3/4 x 10-1/4 x 28-1/2
J	Side Panels (2)	3/4 x 10-1/4 x 16-1/8
K	Seat/Lid (1)	3/4 x 17 x 29-1/2
L	Bottom	3/4 x 15-3/4 x 27
M	Shelf	3/4 x 7-3/4 x 29-1/2
N	Shelf Brackets (2)	3/4 x 7-1/4 x 7-1/4
P	Seat & Shelf Trim	1/4 x 3/4 x 105
Q	Upper Pegs (2)	1 dia. x 6-1/2
R	Lower Pegs (2)	1 dia. x 5
S	Dowels	3/8 dia. x 1-1/2
T	Mirror Opening Veneer Tape	3/4 x 93

Hardware

24" x 36" Mirror
 (50) #10 x 1-1/4" Flathead Wood Screws
 (8) #12 x 1" Roundhead Wood Screws
 (8) 1/4" I.D. Nylon Washers
 One pair, 1" x 2" Hinges

Assembly

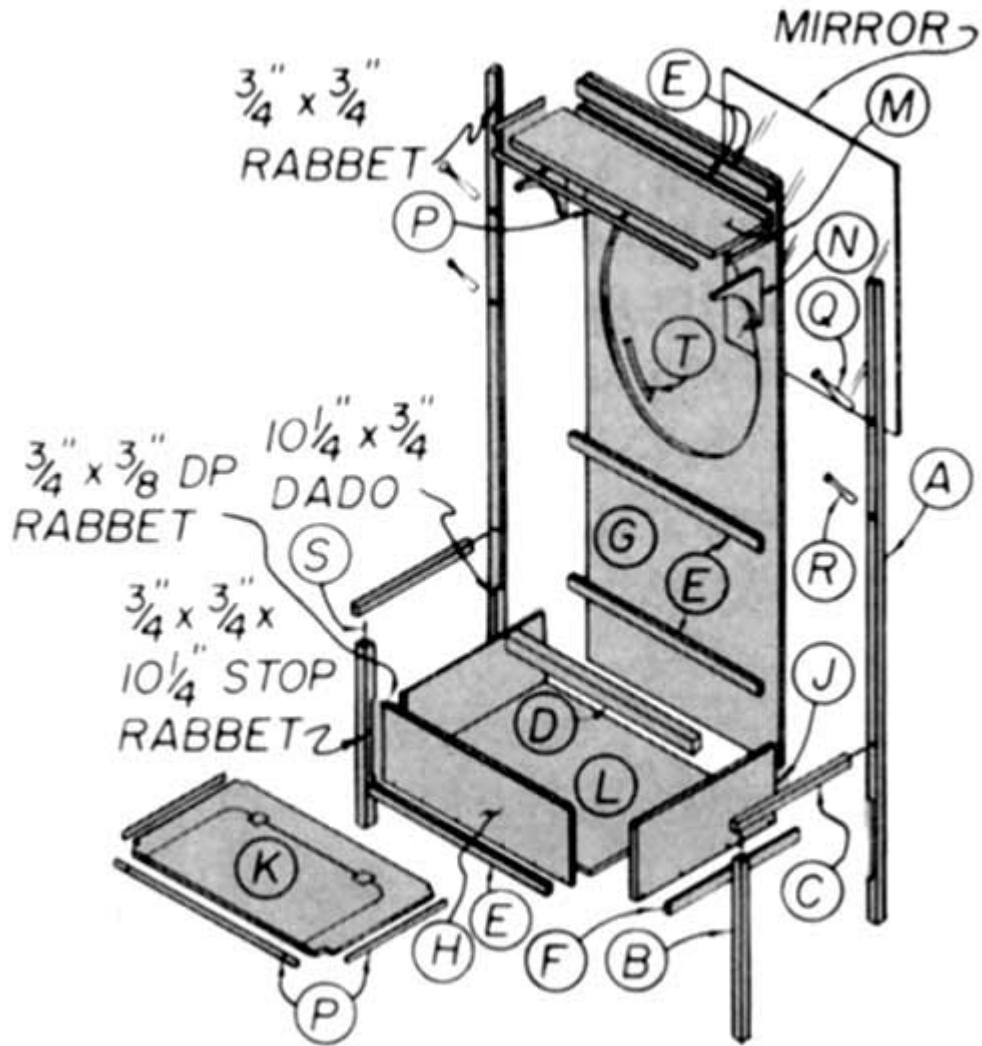

WOODEN TRAIN ENGINE AND SWITCHER



It doesn't really matter whether or not the Pennsylvania Railroad ever had an 8-0-8 switcher...what is important is that kids love trains with lots of wheels. That's why this little jewel is a big hit with children.

If you're building just one, you'll find that the 0-8-0 switch engine and tender will require only about four to six hours to complete. If you're building more than one to give away or sell, each will require less, time, of course. But, no matter how many you decide to make, you'll enjoy the simplicity and ease of the realistic design details. Here's how to make it:

- 1: Glue up a 2-14" x 2-1/4" x 7" turning block for the boiler (A) and steam dome (N). Keep the block clamped for 24 hours before turning. Turn parts A & N at the same time (see plans).
- 2: Using your Scroll Saw, cut the cab side (E) contours out of 3/4" stock, then resaw the stock to make the two sides. Carefully sand the surfaces.
- 3: Cut the remaining parts to size, according to the Bill of Materials.
- 4: Glue-up parts (S, T) to form the tender body. Use your Bandsaw to cut the tender slope, the rabbet on the front of the base (B), and the contours on the supports (H,I). Disc sand the tender and the cab roof (F) contours.
- 5: Use a 1-1/2" hole saw for the engine wheels (O) and a 1-1/4" hole saw for the tender wheels (V) and lights (L, X).
- 6: Prepare a 3/4" x 1" x 2-1/2" piece of stock for the piston supports (J). Drill the two holes then rip the stock in half. Disc sand the bevels (see drawing detail).
- 7: Set-up your drill press to 45° and use your Rip Fence to form a V-Block for drilling the holes in the edges of the headlamp (L) and searchlight (X) for their supports (Q, Y). Glue and clamp the



front and rear supports to the boiler (A), then drill the holes for the headlamp (L), smokestack (M) and steam dome (N).

8: Glue and clamp the axle holder (C) and boiler assembly to the base (B). Next, glue the cab front (D) to the base and sand the cab sides (E) flush. Glue the remaining cab parts to the assembly, then glue parts (L, M, N, Q) into place.

9: Assemble the wheels to the base and sand flush any axles that may be too long.

10: Attach the piston supports to the front boiler support (H) with glue and clamp. After the glue dries, drill a hole through the assembly and insert a 1/4" reinforcing dowel. Disc sand the sides flush then glue and clamp the pistons (K) to the supports.

11: Assemble the tender with glue and clamps. After the glue has thoroughly dried, check all parts of the construction for any loose parts. Drill 3/32" holes in both ends of the engine and tender and install the screw eyes and hooks.



BILL OF MATERIALS

(dimensions in inches)

ENGINE

- A Boiler 2 dia. x 4-1/2
- B Base 3/4 x 2 x 7-1/2
- C: Axle holder 3/4 x 2 x 5-1/4
- D: Cab front 3/8 x 2 x 2-3/4
- E: Cab sides (2) 3/8 x 3 x 4-1/4
- F: Cab roof 3/8 x 3 x 3-1/2
- G: Cab roof vent 1/8 x 3/4 x 3-1/4
- H: Front boiler support 3/4 x 1 x 2-7/8
- I: Rear boiler support 3/4 x 1-1/4 x 2
- J: Piston supports (2) 3/4 x 1/2 x 2-1/2
- K: Pistons (4) 1/2 dia. x 1-3/8
- L: Headlamp 1-1/8 dia. x 3/4
- M: Smokestack 3/4 dia. x 2-1/4
- N: Steam dome 1 dia. x 1-3/8
- O: Wheels (8) 1-3/8 dia. x 3/8
- P: Axles (4) 1/4 dia. x 2-7/8
- Q: Headlamp support 1/4 dia. x 1

TENDER

- R: Base 3/4 x 2-3/4 x 5-1/2
- S: Tender sides (2) 1/2 x 2 x 5-1/4
- T: Tender tank 1-1/2 x 2 x 3-1/4
- U: Axle holders (2) 1 x 2 x 1-3/4
- V: Wheels (8) 1-1/8 dia. x 3/8
- W: Axles (4) 1/4 dia. x 2-7/8
- X: Searchlight 1-1/8 dia. x 3/4
- Y: Searchlight support 1/4 dia. x 1-1/4
- Z: Ladder rungs (7) 1/8 x 3/8 x 3/4

MISCELLANEOUS

- 1-5/8" screw hooks (2)
- 1-5/8" screw eyes (2)

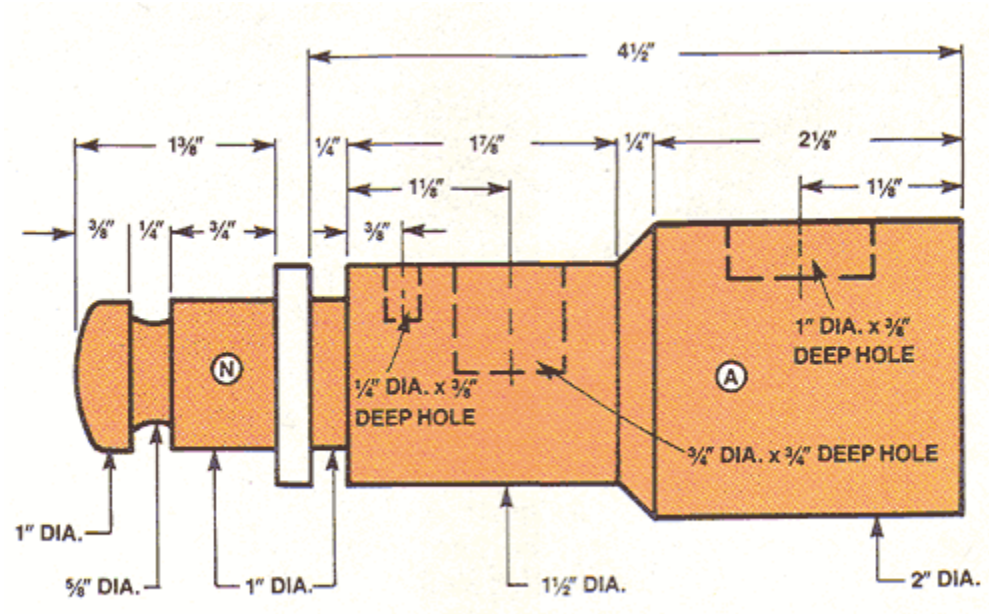

BOILER/STEAM DOME DETAIL

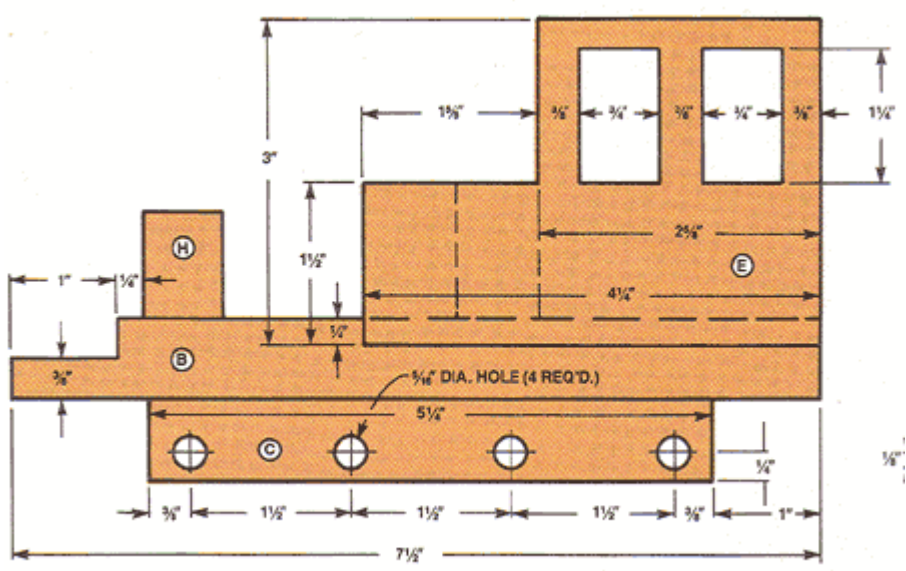

ENGINE SIDE DETAIL

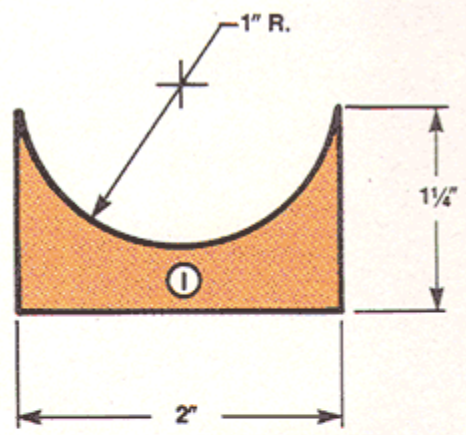

REAR BOILER SUPPORT DETAIL

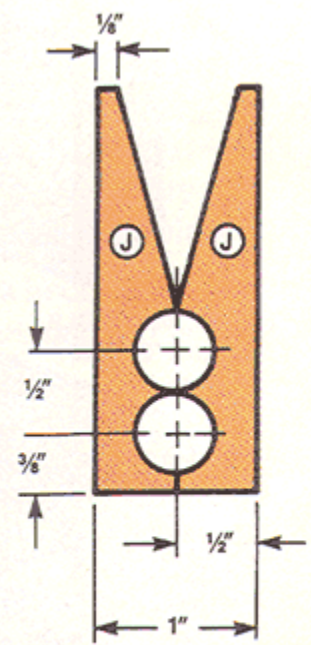

NOTE: DRILL 1/2" HOLES, RIP STOCK, CHAMFER ENDS.

PISTON SUPPORT DETAIL

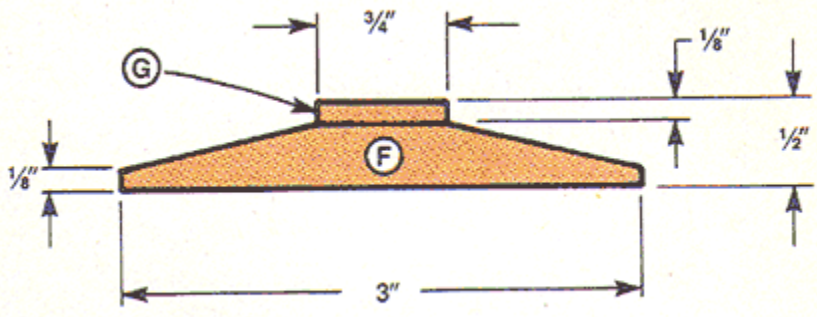

ROOF DETAIL

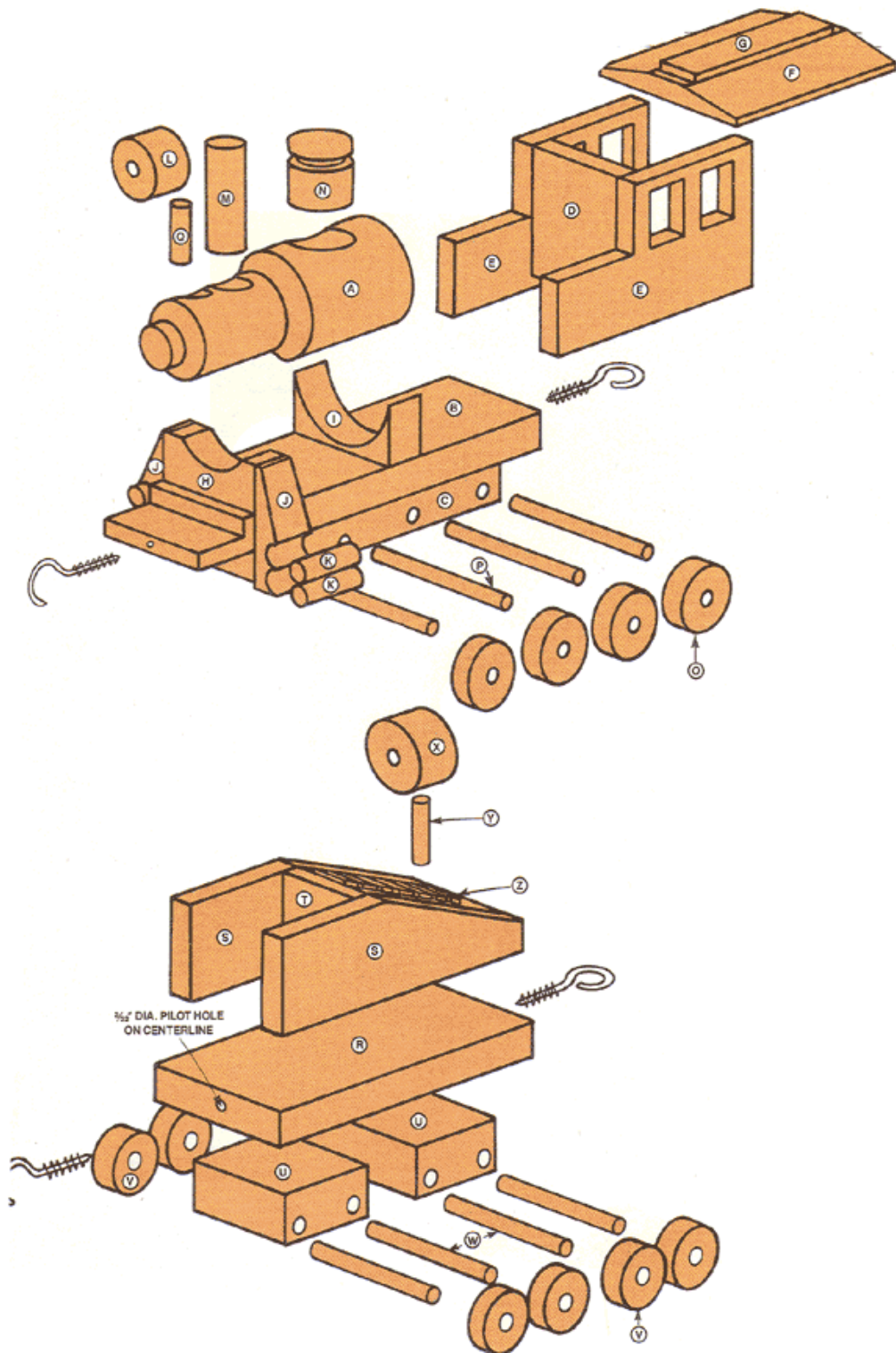

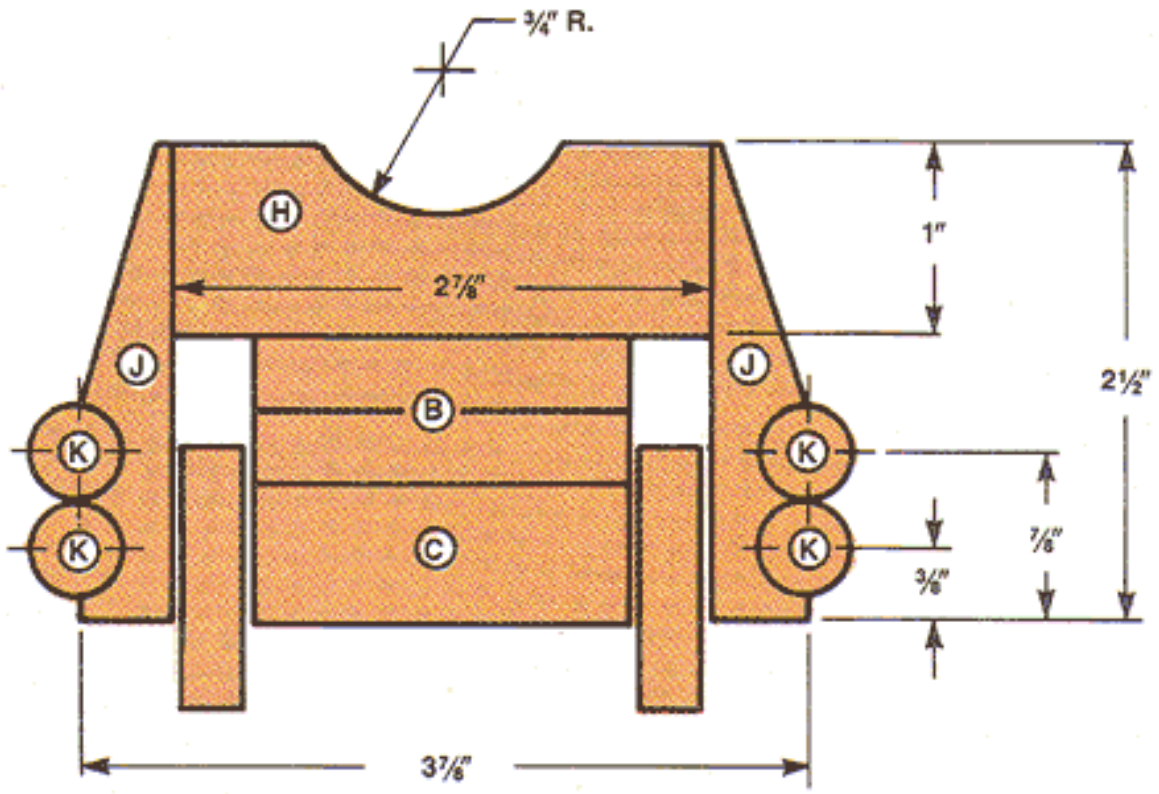

ENGINE FRONT DETAIL

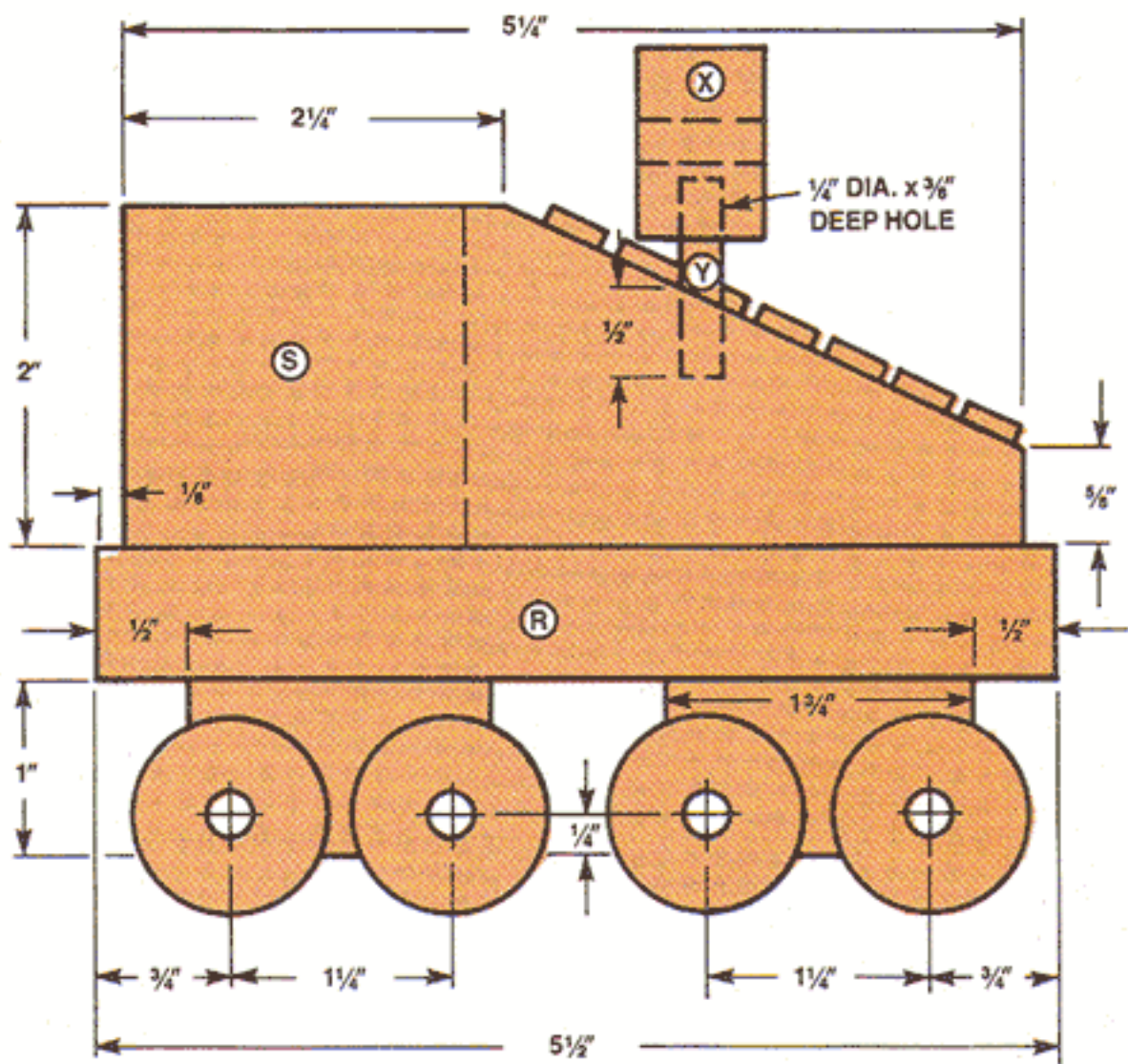

TENDER SIDE DETAIL