

Table Saw

SECRETS

TIPS, TECHNIQUES, PLANS, & PROJECTS

375+
ILLUSTRATIONS
& PHOTOS



**Top Tips for
Perfect Cuts**

**Must-Have Shop-Built
Jigs & Accessories**

Easy-to-Master Techniques

**Table Saw Upgrades—
Space-Saving Storage Solutions**

**Essential Joinery—
Perfect Results Every Time!**



table saw secrets

President & Publisher: Donald B. Peschke

Editor: Terry J. Strohman

Managing Editors: Vincent Ancona, Bryan Nelson

Senior Editors: Ted Raife, Phil Huber

Associate Editors: Dennis Perkins, Randall A. Maxey

Assistant Editors: Carol Beronich, Catherine Seiser

Editorial Intern: Brianna Nelson

Executive Art Director: Todd Lambirth

Art Director: Cary Christensen

Senior Graphic Designers: Bob Zimmerman, Jamie Downing,
Randy Shebeck

Senior Illustrators: David Kreyling, Dirk Ver Steeg

Harlan V. Clark, Peter J. Larson, David Kallemyr

Graphic Designer: Shelley Cronin

Graphic Design Intern: Megan Leafgreen

Creative Director: Ted Kralicek

Sr. Project Designers: Ken Munkel, Kent Welsh,

Chris Fitch, James R. Downing, Mike Donovan

Project Designer/Builder: John Doyle

Shop Craftsmen: Steve Curtis, Steve Johnson

Sr. Photographers: Crayola England, Dennis Kennedy

Associate Style Director: Rebecca Cunningham

Sr. Prepress Image Specialist: Allan Ruhnke

Production Assistant: Minniete Johnson

Video Director/Editor: Mark Hayes

Single Copy Sales: Lisa Trom, Sandy Baum

New Media Manager: Gordon Gaippe

Table Saw Secrets is published by
August Home Publishing Company,
2200 Grand Ave., Des Moines, IA 50312.
Canada Post Agreement 40038201.
Canada BN 84597 5473 RT.

©Copyright 2010 August Home Publishing.

All rights reserved. No part of this book may be reproduced in any form or by any electronic or mechanical means, including information storage and retrieval devices or systems, without prior written permission from the publisher, except that brief passages may be quoted for reviews.

Woodsmith® and ShopNotes® are registered trademarks of August Home Publishing Co.

For subscription information about
Woodsmith or *ShopNotes*, visit us online at:
Woodsmith.com or call (800) 333-5075
ShopNotes.com or call (800) 333-5854

A Supplement to August Home Publications

AUGUST HOME
PUBLISHING COMPANY

2200 Grand Ave., Des Moines, IA 50312

Printed in U.S.A.

SHOP SAFETY IS YOUR RESPONSIBILITY

Using hand or power tools improperly can result in serious injury or death. Do not operate any tool until you read the manual and understand how to operate the tool safely. Always use all appropriate safety equipment as well as the guards that come with your tools and equipment and read the manuals that accompany them. In some of the illustrations in this book, the guards and safety equipment have been removed only to provide a better view of the operation. Do not attempt any procedure without using all appropriate safety equipment or without ensuring that all guards are in place. August Home Publishing Company assumes no responsibility for any injury, damage, or loss suffered as a result of your use of the material, plans, or illustrations contained in this book.

EDITOR'S NOTE

For me, the table saw is one of the most versatile, must-have tools in the shop. And this book will help you get more out of it.

We start off with some tips for getting and keeping your saw running at peak performance. Next, you'll learn the secrets of cutting tight-fitting joinery. We'll also show you some of our shop-tested techniques for making perfect cuts on the table saw.

Then we've included our favorite jigs and accessories to make your work at the table saw faster, safer, and more accurate.

Finally, be sure to check out the chapter on upgrades and add-ons. Here we'll show you how to turn your table saw into a complete, full-featured workcenter.

I'm sure you'll find this book to be an essential "upgrade" for your table saw. For even more information, don't forget to check out the bonus material highlighted on the back cover.

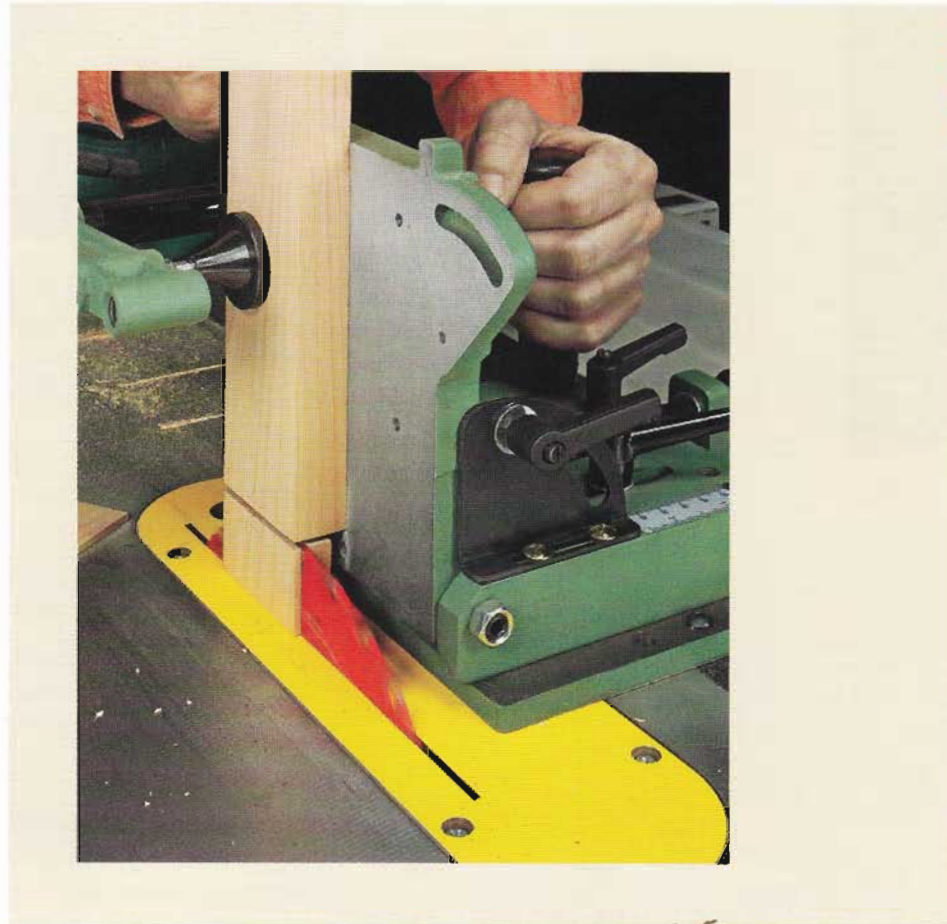

Terry

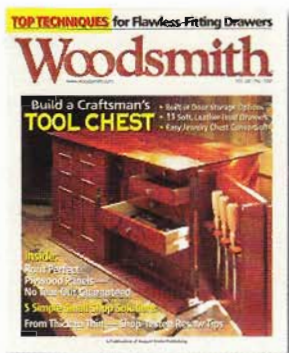

Woodsmith.com

GET MORE

- Tips
- Projects
- Techniques

in Every Issue

ORDER ONLINE



ShopNotes.com

contents



start with the basics

7-Step Table Saw Tune-Up 8

Make sure your table saw is in tip-top shape with this simple tune-up.

Avoiding Kickback 12

Minimize the chance of kickback at the table saw with these foolproof tips.

Precision Crosscuts 14

You can get perfect crosscuts with the proper setup and the right techniques.

Ripping Long Stock 16

Take the hassle out of tough rip cuts with a few workshop "helpers."

Saw Blade Maintenance 18

Learn how to get better results and longer life out of your blades

Choosing Blade Cleaners 20

Use these shop-tested cleaning products to keep your blades cutting efficiently

Motor Wiring 22

Here's what you need to know about wiring your power tools for 240v.



essential joinery

Dead-On Dadoes 26

We'll show you the secrets to cutting clean, crisp dadoes in any material.

Tongue & Dado Joinery 28

This joint is easy to master and perfect for building strong, sturdy projects

Rabbeted Cases 32

With ordinary rabbet joints, you can create rock-solid cases in no time

Top-Notch Tenons 34

A tenoning jig and a step-by-step process are all you need to cut perfect tenons

Tenon & Groove Joinery 38

Use our tips to make this solid and dependable joint on the table saw



advanced techniques

Making a Bevel Rip Cut 42

The key to a perfect bevel cut is simple — just start with the setup.

Cutting Perfect Circles 44

Believe it or not, you can cut circles on the table saw with this shop-built jig.

Traditional Raised Panels 46

Raised panels on the table saw? We'll show you just how straightforward it is.

Pattern Cutting 48

Hard-to-cut, identical parts are a cinch with pattern cutting on the table saw.



jigs & accessories

Precision Crosscut Sled 52

This sled creates dead-on crosscuts, and an attachment makes box joints a snap.

Fence Accessory System 60

Your table saw's rip fence serves as the backbone for these must-have add-ons.

Small Parts Jig 66

You can rip and crosscut even the smallest pieces with this table saw accessory.



upgrades & add-ons

Table Saw Workcenter 74

With these custom upgrades, your table saw will be able to handle any project.

Space-Saving Ideas 86

Make the most of limited space with four practical ideas for your table saw.

All-In-One Project Station 88

Replace the wings of your table saw, and turn it into a multi-purpose work area.

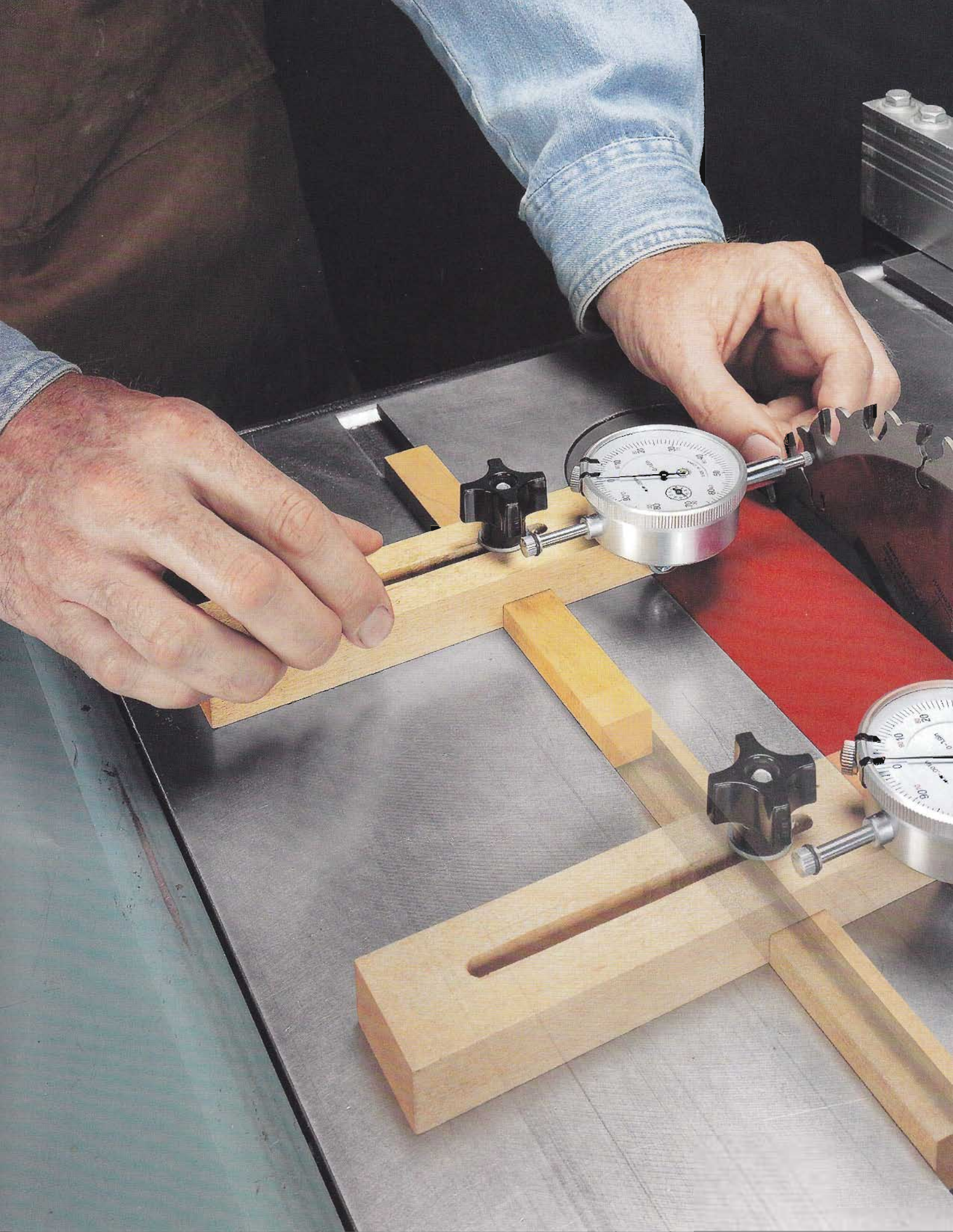

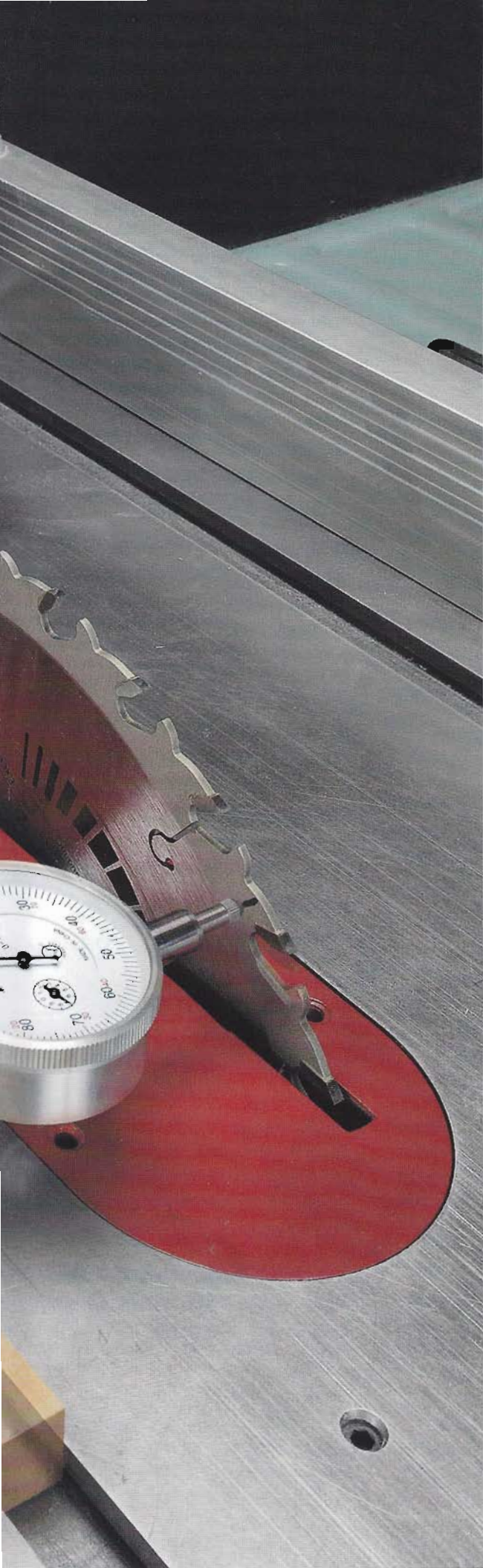
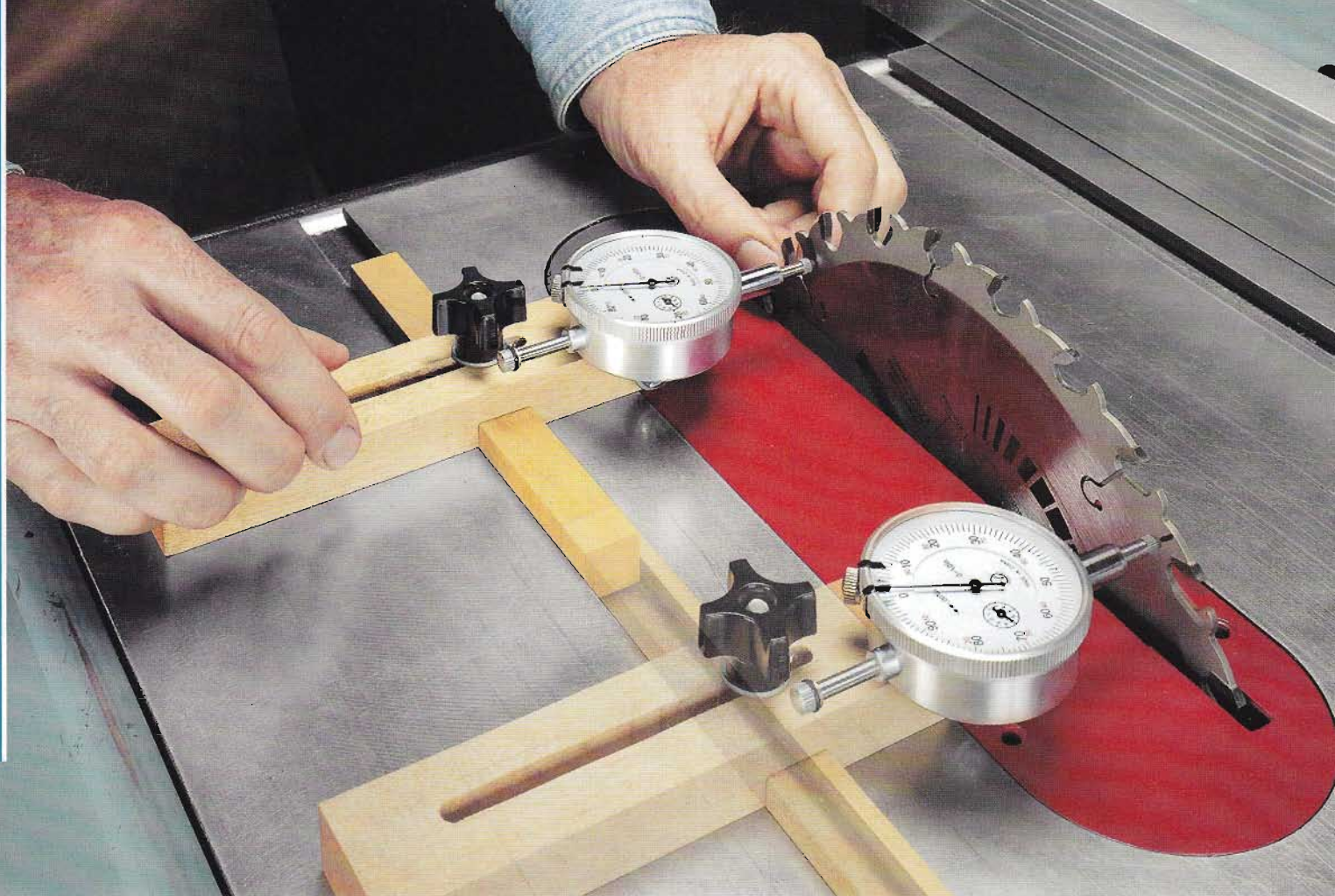

Table Saw Basics

Before putting your table saw to work, a tune-up will make sure it's in proper shape. Plus, our tips on maintenance and tackling basic cuts will make using your saw safer and easier.

7-STEP TABLE SAW TUNE-UP	8
AVOIDING KICKBACK	12
PRECISION CROSSCUTS	14
RIPPING LONG STOCK	16
SAW BLADE MAINTENANCE	18
CHOOSING BLADE CLEANERS	20
MOTOR WIRING	22



7-Step Table Saw Tune-Up

To ensure your table saw makes smooth, straight, and square cuts — project after project — it pays to set aside a little time for a tune-up.

Solvents and brushes are the tools of choice for removing built-up pitch and resin.



In most shops, the table saw is the center of activity and the tool that sees the most use on just about every project. Whether it's cutting sheet goods, ripping hardwood boards to size, or cutting precision miter joints, the table saw is a real workhorse.

So it's easy to take your saw's performance for granted. After all, its cast iron top and rugged interior don't appear to need a lot of delicate care. But to keep it cutting reliably and safely, it's a good idea once or twice a year to devote an afternoon to the routine maintenance and adjustments it requires.

The good news is, you don't have to be an engineer to bring your saw's performance up to peak efficiency. The following operations are pretty straightforward and will keep your saw working at its best.

Before getting started, though, I pull out my owner's manual. Your manual may or may not cover the maintenance procedures in depth, but it should at least help you find the parts that need adjustment and offer advice on the wrench sizes or other tools needed for the tune-up. Whenever they're listed, I set them out on the bench for easy access.

1 Basic Cleaning

Before you start adjusting and tuning your saw, it's helpful to clean it thoroughly. This makes it easier to access the parts and gives you a chance to look for broken or damaged components.



A paint brush works great for getting into the tough-to-reach parts of your table saw.

I usually begin by vacuuming the saw inside and out, reaching as far in as I can to clean up the gears. The brush attachment of a shop vacuum takes care of most of the surface dust and debris. But it will only get you so far.

For the harder-to-reach areas, a paint brush works well (left photo). And compressed air helps clear out the dust the brush dislodges. If the dirt is really stubborn, a little solvent on the tip of the brush will loosen and dissolve pitch and resin. This is also a good time to lubricate the gears. I prefer to use wax or a dry lubricant so sawdust won't stick to it.

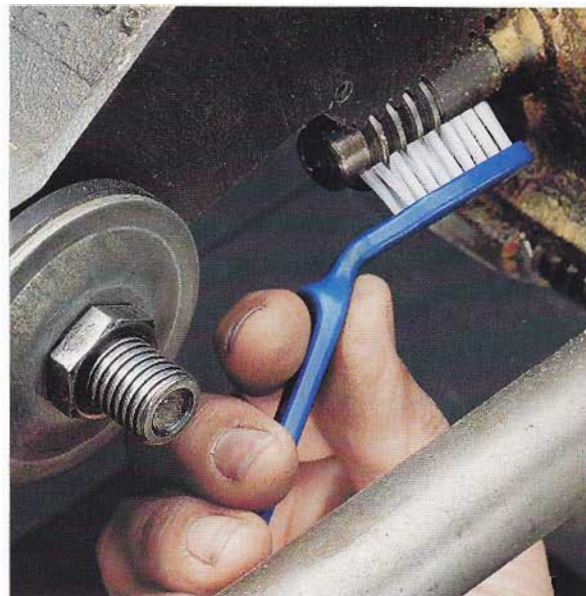

Gears can become stubborn and hard to turn if the teeth are filled with sawdust, pitch, and resin. The stiff bristles of a toothbrush clean them out in a hurry.

2 Be on the Level

In order to make square cuts, your saw's worksurface must be perfectly flat. If one of the extension wings is higher than the main table, a workpiece will not be level during a cut. This can make it difficult to get flush-fitting joints.

You can check the wings by laying a long straightedge across the table (photo at right). On most saws, all you need to do is loosen a couple of bolts on the extensions to make the necessary adjustments. Make sure

to check the fit at both the front and back of the saw table.

The throat insert also needs to be flush with the surface, or a workpiece may catch the edge or rock during a cut. In either case, it can be a safety issue and will result in less than perfect cuts.

Most inserts have leveling screws that you adjust with an Allen wrench. You can use a metal ruler to check for gaps. Then, adjust one screw at a time until the insert is level with the surface.

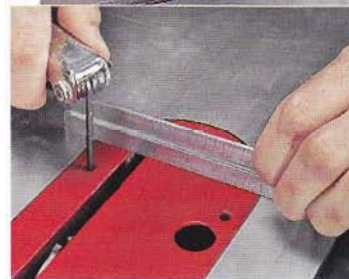
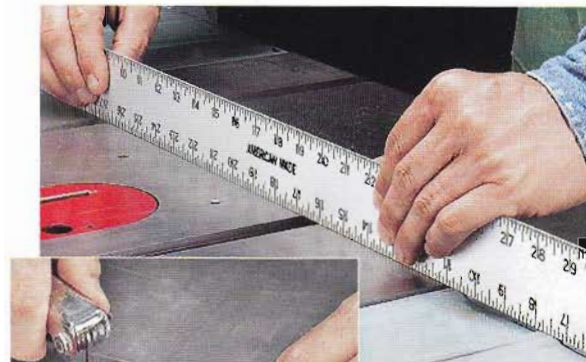

A straightedge helps point out high or low spots in the table and throat insert.

3 Check for Runout

In a perfect world, table saw blades would turn without any side-to-side movement. In reality, there's usually deviation caused

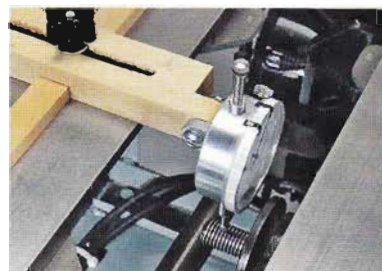

A flat tip on the dial indicator spans the threads of the arbor for an accurate reading.

by the arbor or flange not being perfectly straight or flat. This condition, known as runout, reduces the quality of the cut.

The best way to check for runout is to measure the arbor and flange with a dial indicator. I use a shop-made holder for both jobs, as shown in the photos. A dial indicator is inexpensive and accurate (refer to Sources on page 98). And you can find a plan for the holder on page 11.

The photos show how to measure for runout on the arbor and flange. Position the indicator, turn

the arbor by hand, and watch the needle for movement. I like to see runout less than .005". If you're getting more than that (and certainly if it's in the .010" range), you may have a more serious problem, like bad bearings or a bent arbor.



To measure the flange for runout, tilt the arbor and keep the indicator perpendicular to the face to ensure an accurate reading.

4 Align the Blade & Miter Slot

After checking the arbor, use the dial indicator to make sure the blade and miter slot are parallel.

Start by making a reference mark on the blade. By measuring



A dial indicator can measure the distance to the blade at two positions, helping you determine if the blade is parallel to the miter slot.

only at this mark, you avoid any surface imperfections on the blade and are assured of getting a more accurate reading.

Next, place the dial holder in the miter slot (photo at left), and slide the indicator into position. For the first measurement, place the marked spot on the blade toward the front of the saw and position the tip of the indicator so it's touching the mark on the blade. By zeroing out the indicator in this position, you establish the baseline measurement.

Then rotate the blade toward the back of the saw and slide the indicator back to again touch the mark on the blade. If the



On a contractor's saw, aligning the blade and miter slot means adjusting the trunnions.

dial doesn't move, then your saw is aligned. If it does move, make note of how much. On a contractor-type saw, you can usually correct the problem by adjusting the trunnions. For a cabinet saw, the adjustment probably involves adjusting the position of the table. Refer to your owner's manual for the correct procedure for your saw.

5 Align the Pulleys

Another potential source of problems is the alignment of the motor and arbor pulleys. If they're not both turning in the same plane, the drive belt can deflect slightly and cause significant vibration in the saw. Fortunately, this is pretty easy to check and correct.

You can determine if the pulleys are aligned by resting a straightedge on the outside faces of both pulleys. (You can use a narrow piece of wood, as shown at right, if you don't have a long enough straightedge.)

If the straightedge rests flat on both pulleys, they're in good shape. If there's a gap, you'll need to shift the position of one of the pulleys on the shaft. Usually it's just a matter of loosening the pulley's Allen screw and sliding it into position.

If you still have vibration, you might want to replace the standard "V"-type drive belt that came with your saw with a link belt. Another option is to upgrade the factory-installed, cast pulleys with machined replacements.



Use a straightedge resting on the face of the motor and arbor pulleys to check if they're aligned.

6 Set the Stops

Because cuts at 45° and 90° are so common, most table saws have adjustable stops for each of these settings. But through repeated movements, the stops can be bumped out of alignment.

Manufacturers use different methods of adjustment, so here again, you'll need to consult your owner's manual for specific instructions. If you take a look at the photos at left, you'll notice that set screws in the top of the saw are used to make adjustments.

To check the stops, start by raising the blade to full height. Then, use a square or a drafting triangle, as shown in the photos at left, to set the blade to 90°. Now just set the stop to match.

To confirm the setting, tilt the saw blade a few times and return it to the 90° setting. Measure each time to verify the stop's accuracy, and make adjustments until you're satisfied with the results.

Then complete this same procedure for the 45° stop.

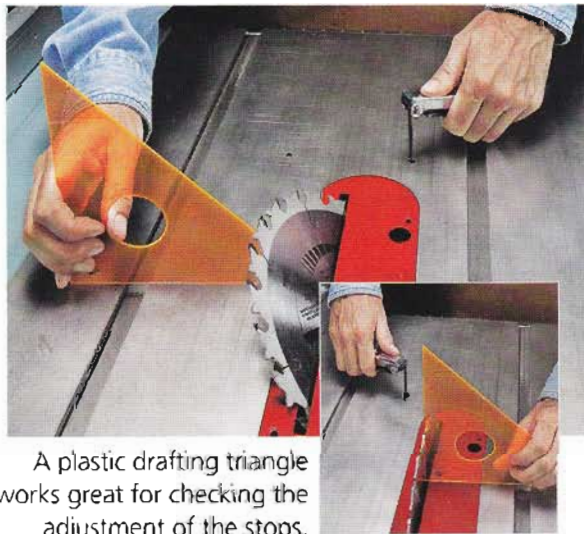

A plastic drafting triangle works great for checking the adjustment of the stops.

7 Square the Miter Gauge & Rip Fence

With the adjustments to the saw complete, it's time to turn your attention to the accessories you'll use to make virtually every cut — the rip fence and miter gauge.

I start by squaring the miter gauge to the saw blade. This is an effective method since you've already aligned the blade to the miter slot. Using a drafting triangle against the plate of the blade (be sure it's not touching a tooth), loosen the miter gauge and set it to match the square side of the triangle. You can see what I mean in the photo below.



To align the miter gauge, keep the drafting triangle on the plate of the saw blade, not the teeth.

There are two schools of thought regarding the alignment of the rip fence. Most recommendations suggest setting the fence parallel to the blade. But some woodworkers prefer to have it angled slightly away from the blade so the fence doesn't push the workpiece against the blade and cause kickback. If you choose to add a slight angle to the fence, it shouldn't exceed .003".

It's very important that the fence never be angled toward the blade, or kickback could result. You can measure the fence with

the dial indicator, like you see in the lower right photo.

Finally, check to make sure the fence is square to the table. You won't need to adjust this very often, but it's still worth taking a minute to check. Then your saw will be ready for the next project.

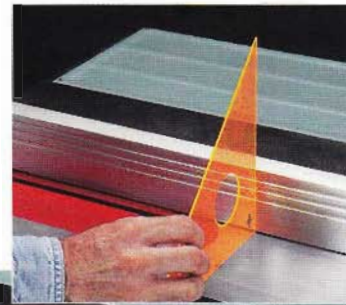

Check the fence to ensure it's square to the top of the table.



Use the dial indicator to determine if the fence is parallel to the miter slot (and blade). Take readings all along the length of the fence and adjust it according to the instructions in your owner's manual.

How-To: Shop-Made Dial Indicator Holder

A dial indicator is the perfect tool for measuring very small differences in alignment. It's an extremely sensitive and accurate device. But before you can use one, you'll need a way to mount the indicator so you can move it to measure different points while still maintaining an accurate reference. The sliding holder shown in the drawing at right does just that.

A hardwood runner fits tightly into the miter slot to guarantee a stable position. And the sliding base that holds the indicator is easily adjustable. This allows you to move the tip so it can contact the blade or arbor to take the measurement. Finally, the rounded

end of the base allows you to pivot the indicator to any angle.

You can make the sliding holder using hardwood scraps. Start by milling the runner to fit snug in the miter slot. I added two set screws to the runner to tighten the fit in the miter slot. Then cut a notch to house the base.

The base fits into the dado on the runner and is adjustable side to side. To cut the slot for the screw and knob, I just drilled a series of holes and cleaned up the sides with a chisel (the same way you'd clean up a mortise). After drilling a hole to hold the indicator, I rounded the end with a belt sander.

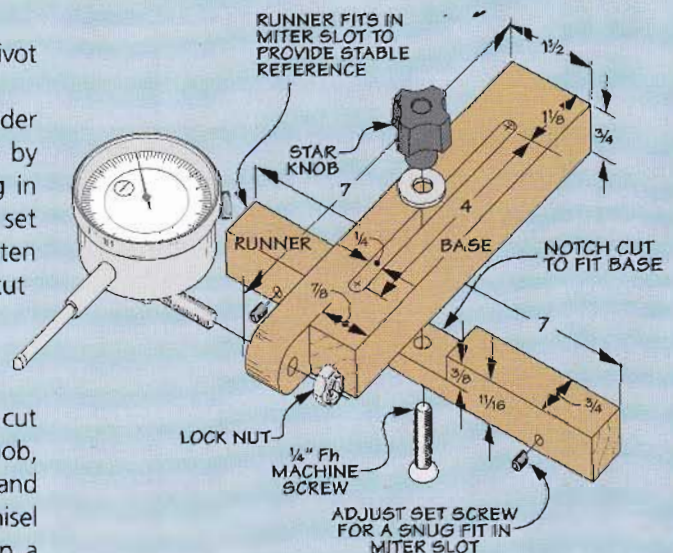



Avoiding Kickback



Outfeed Support. Outfeed rollers are especially helpful for controlling wide or long workpieces.

Here are a few easy steps and simple accessories that are certain to help you rip stock more safely and accurately.

When you look at a table saw, it's easy to see why a spinning saw blade is a danger to your fingers. But the more common hazard is when a workpiece

you're ripping pinches the back of a blade, causing it to "kick back" toward you. Fortunately, this problem is easy to avoid if you follow a few simple rules.

If they're not aligned, consult the owner's manual for your saw.

Another consideration is the height of the blade. The higher the blade is raised, the fewer teeth are in the stock at any time. This means the force of the blade is directed downward, not back, so there's less chance the workpiece will get pushed back toward you.

But, there is a drawback to raising the blade. You may get rougher cuts from the "chopping" action of the teeth. So I compromise and set the blade with the bottom of the gullets just above the top of the workpiece (Side View drawing at left).

SET UP. The most important factor in preventing kickback is to be sure your table saw is set up properly. The blade should be aligned with the miter slot, and the rip fence should be aligned with the blade (drawing at left).

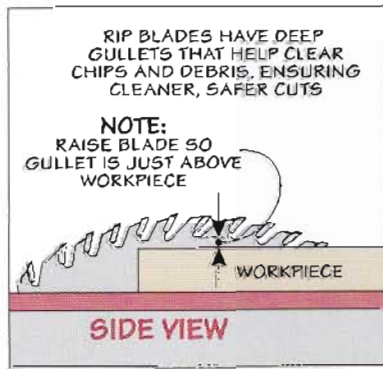
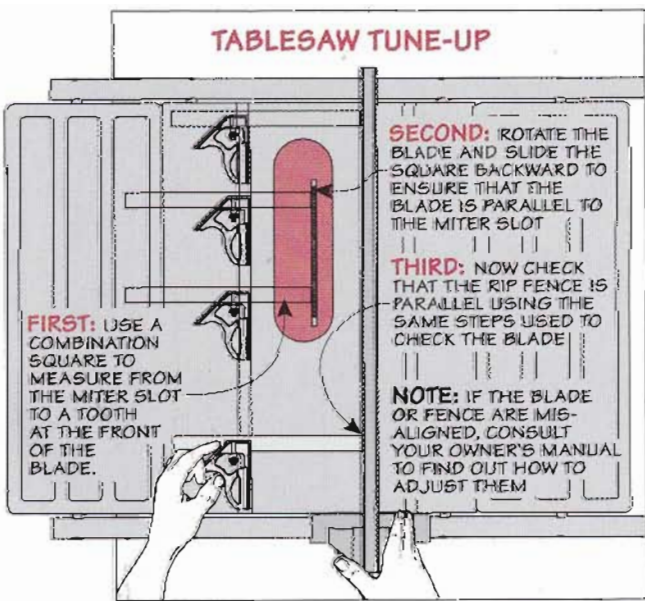

STRAIGHT & FLAT. Another secret to avoiding kickback is to always use flat stock with a straight edge. Straight and flat stock is less likely to shift away from the rip fence or rock on the saw table.

Safe Ripping Techniques

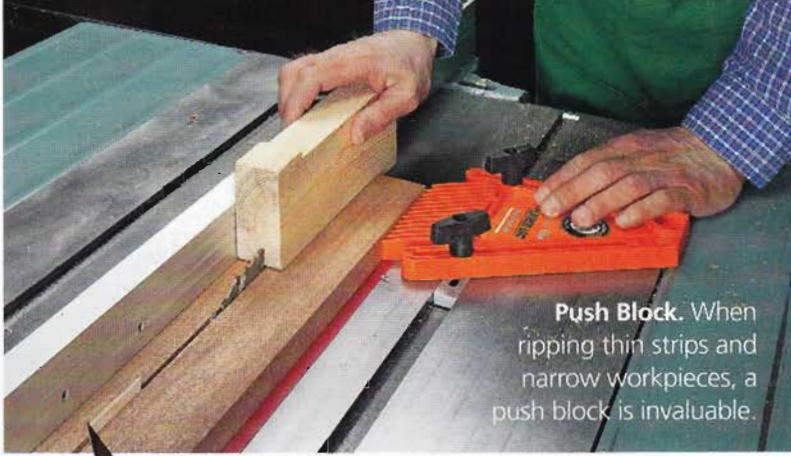

Push Block. When ripping thin strips and narrow workpieces, a push block is invaluable.



Splitter. When a blade guard can't be used, a shop-made splitter works best.



BLADE GUARD. Even with perfectly milled pieces, kickback can still happen when the saw kerf closes in on the back edge of the blade. The key to preventing this is to use the factory blade guard assembly that came with your table saw.

Most have a built-in splitter as well as a pair of spring-loaded pawls that are specifically designed to keep a workpiece from kicking back.

SHOP-MADE SPLITTER. There are times when using the factory blade guard isn't possible (as when ripping really narrow pieces). In that case, it makes sense to use a splitter, like the one shown above.

This shop-made splitter is the same thickness as the saw blade, so it prevents the kerf from closing up and pinching the back of the blade. As an added benefit, the splitter is part of a zero-clearance insert. You can find a video on making an insert with a splitter in the online extras.

SAFETY ACCESSORIES. In addition to the blade guard and splitter, there are a few more safety accessories you can use. These include a good featherboard, outfeed support, and a push block.

A featherboard provides extra control. It's like having a third

hand to hold the workpiece up against the rip fence. The best thing about a featherboard is that the "fingers" allow the workpiece to move in only one direction, decreasing the chance that the workpiece will kick back.

Another accessory I use, especially when working with long or wide workpieces, is a roller stand. You can see an example in the inset photo on the opposite page.

Finally, a push block helps you maintain firm control over a workpiece while keeping your hands and fingers up out of harm's way. The one shown in the photo above is made from scrap "two-by" stock.

PROPER TECHNIQUE. The position of your body, where you place your hands during the cut, and how you hold the workpiece are all extremely important, as well. For example, never stand directly behind a workpiece while making a cut. Not only does this keep you safe, but it also dictates the position of your hands as you push a workpiece up to and past the blade. Learn more about the proper feed technique in the box at right.

The good news is that if you use these simple techniques, kickback can be avoided.

To make safe, accurate cuts, you need to maintain constant control of the workpiece while moving it past the blade in a smooth, steady motion.

The step-by-step process shown in the three drawings below should clear up questions about how to achieve this goal. The first drawing explains how to use both hands to start the cut. Then, use a push block to control the workpiece as you push it past the blade. Finally, to safely finish the cut, don't let go of the workpiece until it is completely clear of the blade.

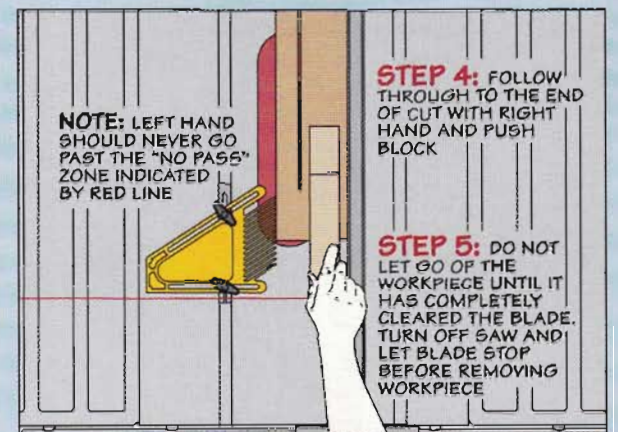
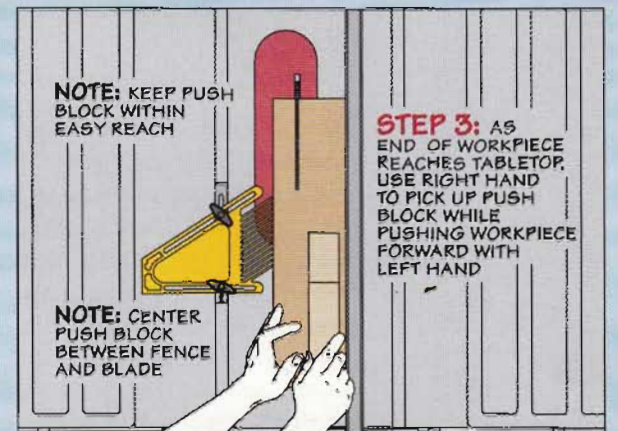
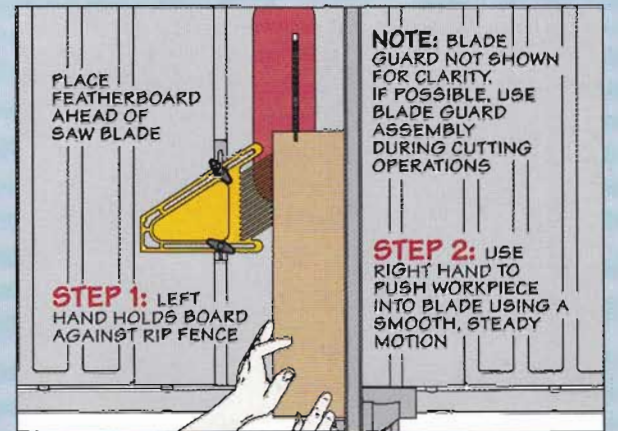

Hassle-Free Precision Crosscuts

A smooth, clean crosscut is guaranteed with the right setup and these tips and techniques.

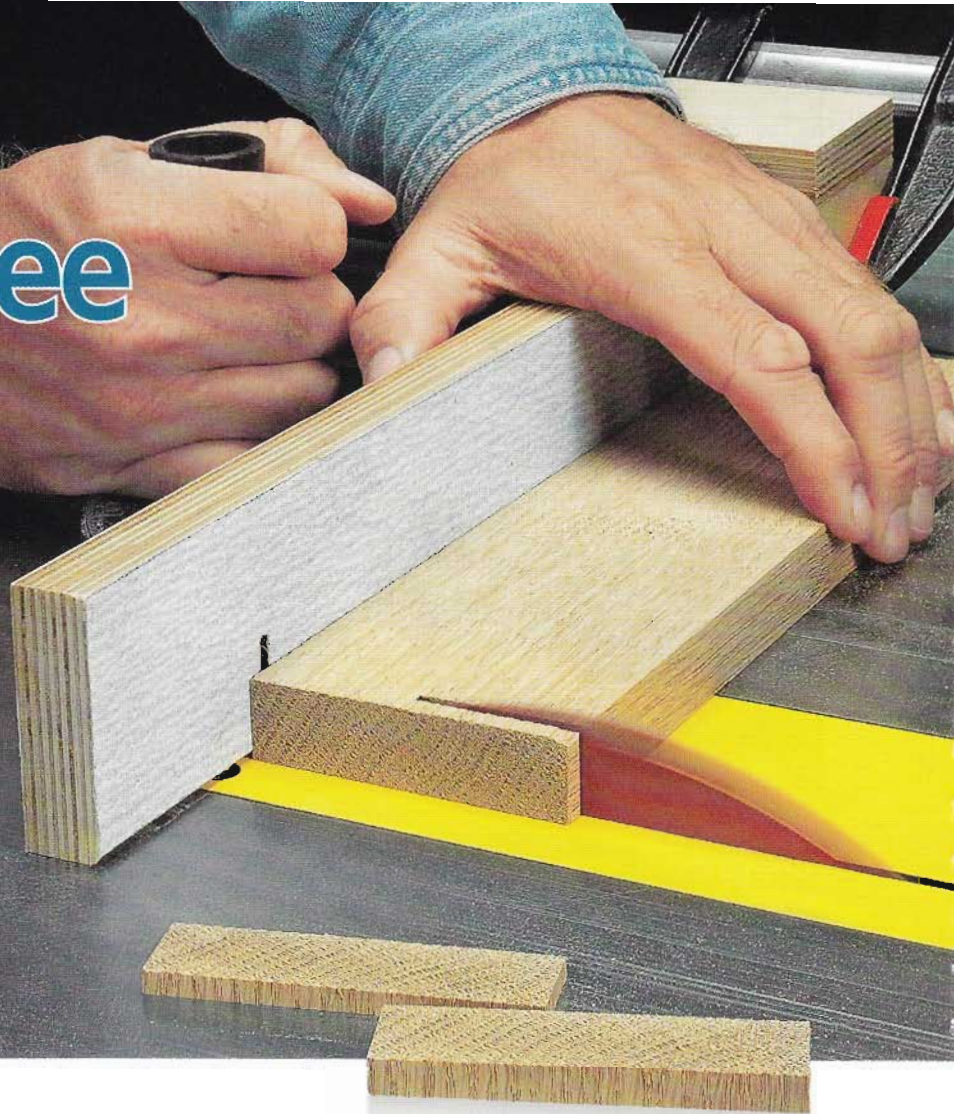

There's nothing more basic in woodworking than a crosscut on a table saw. But even with a perfectly tuned-up saw, you may still end up with splintering, tearout, burning, or saw marks marring your cut. By using the following tips and techniques, you can get smooth, tearout-free crosscuts on your table saw every time.

TABLE SAW SETUP

Most crosscut challenges can be dealt with before you even begin to make the cut. The first step to accurate crosscuts is setting up your table saw. And for that, I turn to a couple of accessories, like the auxiliary miter gauge fence and zero-clearance insert you see in the drawing below.

AUXILIARY FENCE. The auxiliary fence I use is just a strip of plywood that extends beyond the blade, like you see in the main photo. This way, the workpiece is fully supported on both sides of the blade, minimizing any chance of tearout. Plus, the cutoff is pushed safely past the blade.

Another benefit is that it provides an easy way to clamp a stop block in place (more on this later). Finally, adding some self-adhesive sandpaper to the fence keeps the workpiece from shifting during the cut.

ZERO-CLEARANCE INSERT. While an auxiliary fence prevents tearout along the back edge of a workpiece, it doesn't help along the bottom face. As the teeth of the blade exit the bottom of the workpiece, they can cause tearout — especially with the wide opening in most table saw inserts. So it's

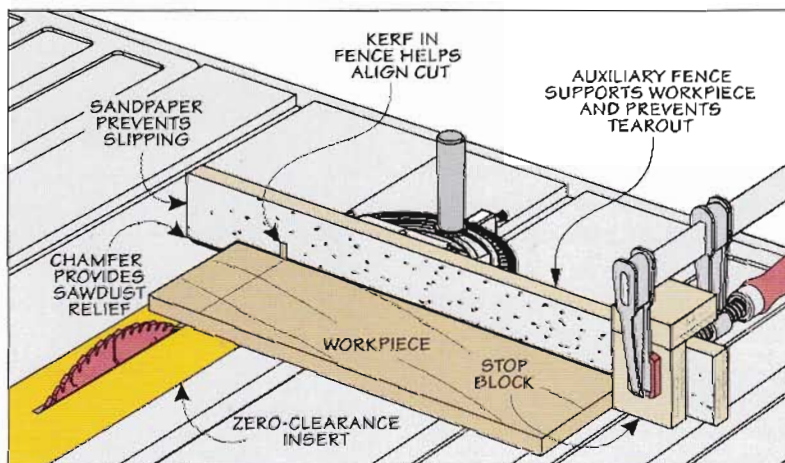

best to make a crosscut with the good face of the workpiece up.

But what if you need a clean cut along both faces? The solution is a zero-clearance insert. It supports the workpiece right up to the edge of the cut. As an added bonus, the insert prevents the cut-off from getting wedged in the blade opening and kicking back.

TIPS & TECHNIQUES

Using an auxiliary fence and zero-clearance insert will give you a good start to better crosscuts. And adding a dedicated crosscut blade can help (box below). But there are still a few techniques for getting better crosscuts.

SMOOTH & STEADY. As you feed the workpiece through, keep it moving steadily. Burning is a sure sign you're moving too slow, while blade marks and a lot of tearout mean you're going too fast.

COMPLETE THE CUT. Be sure to push the workpiece all the way past the blade, then slide it away. Pulling the workpiece back across the blade can spoil the cut edge.

REPETITIVE CUTS. These techniques will produce a clean cut. But when I need to make several identical parts, I've found it's hard to get consistent results. So, instead of measuring each part, I use an adjustable, L-shaped stop block, as you see in the photos above.

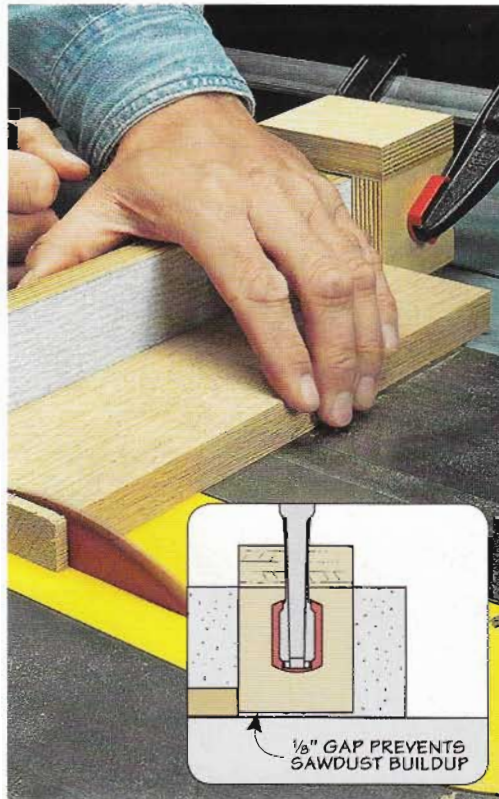

Stop Block. Clamping a stop block to the auxiliary fence allows you to cut several parts to the same exact length.

To make repetitive cuts, clamp your stop block in place. Then all you have to do is butt each workpiece against the block, and you'll get consistent pieces quickly.

SHORT PIECES. When I need to cut a number of short pieces, this method puts my fingers too close to the blade. To make the cuts safely, I simply flip the stop block

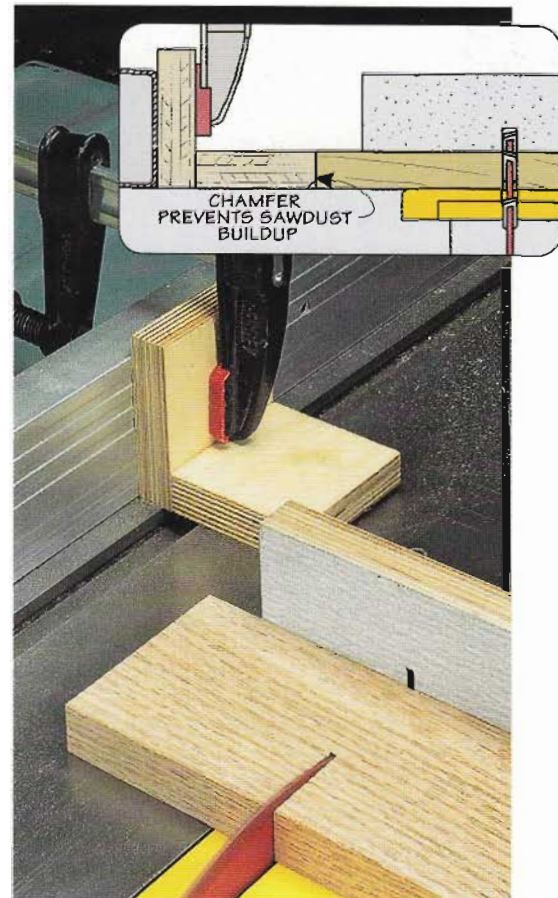

over and clamp it to the rip fence, as shown in the right photo.

By clamping the block in front of the blade, you can still position each workpiece identically. As you make the cut, a gap opens up between the workpiece and the fence, so the cutoff isn't trapped. And once again, the end result will be a flawless crosscut.

Offset Block. When crosscutting short pieces, clamp the block to the rip fence — a few inches in front of the saw blade.

Saw Upgrade: Crosscut Blade

Setup and technique go a long way toward getting a good crosscut on a workpiece. Another way to improve your crosscuts is to use a saw blade specifically designed for the task, like the crosscut blade you see in the photo at right.

While a typical saw blade may have 40 or 50 teeth, a dedicated crosscut blade may have 80 or more. Plus, the teeth are ground with alternating top bevels.

So what does all this mean? Well, the extra teeth mean each one is taking less of a bite. So it's not aggressively tearing away at the fibers. And the alternating top bevel grind means a smooth shearing cut through the fibers.

The end result is less splintering and clean, crisp edges on both sides of the cut. For the ultimate super-smooth cut, a dedicated crosscut blade is your best choice.

Crosscut Blade. The high tooth count and alternating bevels work together to give you a top-notch crosscut.

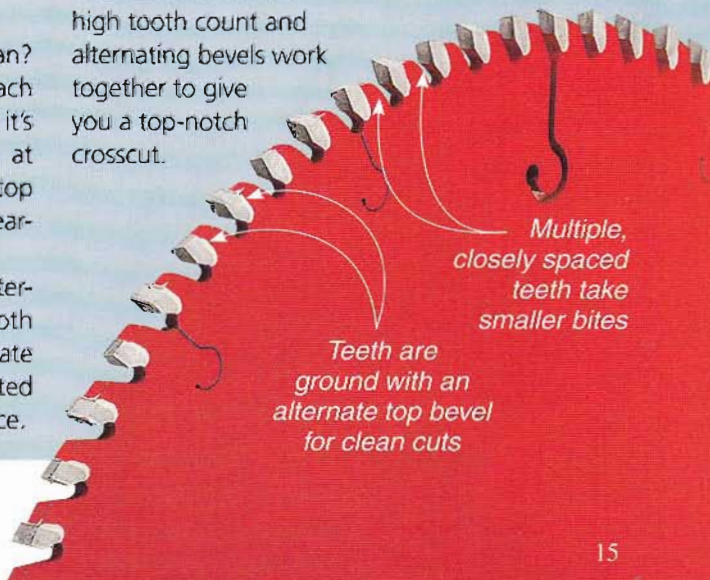

Ripping Long Stock

Does the thought of ripping long stock on the table saw make you cringe? Some good outfeed support might be the answer.

Of all the cuts I routinely make at the table saw, safely and accurately ripping long pieces of stock is one of the biggest challenges. The problem is that to get good results, there are a number of things you have to pay attention to — all at the same time. You're trying to keep a large, bulky piece of stock tight against the rip fence while feeding it into the blade and keeping your hands out of the way. And if this isn't enough, how do you manage to keep the long board flat on the saw table all through the cut? Well, I've found that one way to make this

tough job a bit easier is with some well-placed outfeed support.

THE PLUSES. Good outfeed support takes one big concern "off the table." It allows you to concentrate on accurately feeding the stock. Your feed rate will be more consistent, which means the cut will be smoother and "burn-free." And because there's less chance of the stock wandering away from the fence, the cuts are more accurate.

But the most important benefit of being able to focus entirely on feeding the stock is safety. When you have complete control of the stock, there's much less chance of something going wrong.

A SIMPLE SUPPORT. Most of us don't have the space in our shop for a large, permanent outfeed table. Folding roller stands can be a good option for extra support. But if you don't have one, there's another easy solution. As you see in the drawings on this page, a simple, shop-built outfeed support can work just as well.

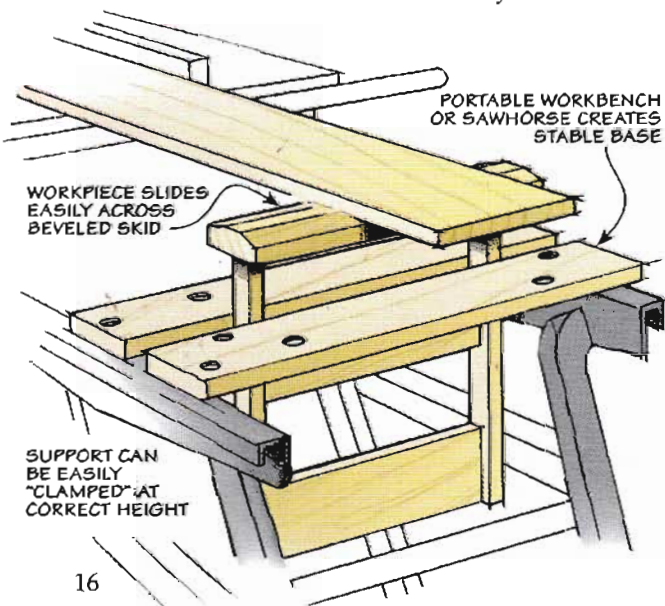
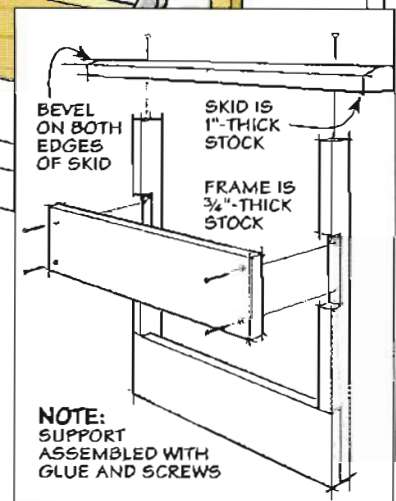
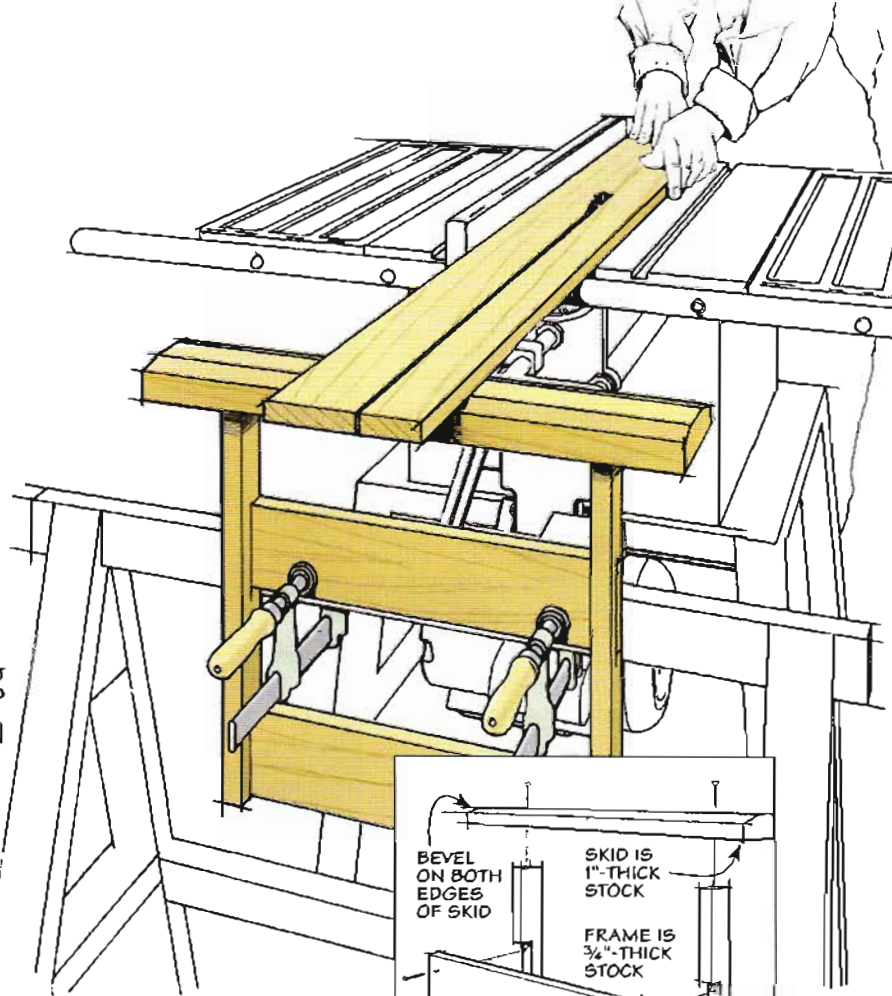

This support costs little to build and the finished product is lightweight, compact, and easy to store. Just hang it on the wall. A portable workbench or sturdy sawhorse can be used to give the support a wide, stable stance.

Instead of a roller, this support uses a wide, beveled, hardwood skid to support the workpiece. The narrow support surface creates minimal resistance, which makes for a smooth, easy feed. And beveled edges ensure that the workpiece won't hang up.

SET IT UP RIGHT

To make an easy job of hard-to-handle rip cuts, your outfeed support needs to be positioned where it will do the most good.

WHAT HEIGHT? The first thing to think about is setting the support at the correct height. The perfect height depends on the type and thickness of stock you're ripping. You can be pretty sure that thick stock (1" plus) won't sag much as it comes off the saw table. So here, I generally set my support level to the table or just a hair below.

For thin or narrow stock, you can expect it to droop a bit, as you see in the top drawing at right. Just drop the support slightly below the surface of the saw table to account for this.

PROPERLY ALIGNED. Next, the support stand needs to be properly aligned with the workpiece as it comes off the saw table. And it should also be placed parallel to the surface of the table.

When I position the stand side to side for a cut, I don't think in terms of centering it on the blade. You need to think about supporting the entire board. Generally, this means centering the support (more or less) on the workpiece (right drawing). But the important thing is that the support stand must carry both "halves" of the ripped board.

Next, you can squat down behind the support and sight across it to make sure the surface is parallel to the table. This is important because if one side is low (or high), the misaligned outfeed support can cause the board to twist and bind against the saw blade or go off line.

THE PERFECT DISTANCE. The final question is, "How far from the saw table do you place the support?" As you might expect, this depends on the board's length.

At the beginning of a rip cut, the saw table supports the workpiece. But once more than half the length of the board is beyond the table, it starts to tip downward. This calls for more support.

So, you need to place the support close enough to the table saw to catch the workpiece before it reaches this "tipping point" (top drawing below). On the other hand, when you push the workpiece past the blade at the end of the cut, you don't want it to pivot up and off of the saw table. This means that you need to avoid

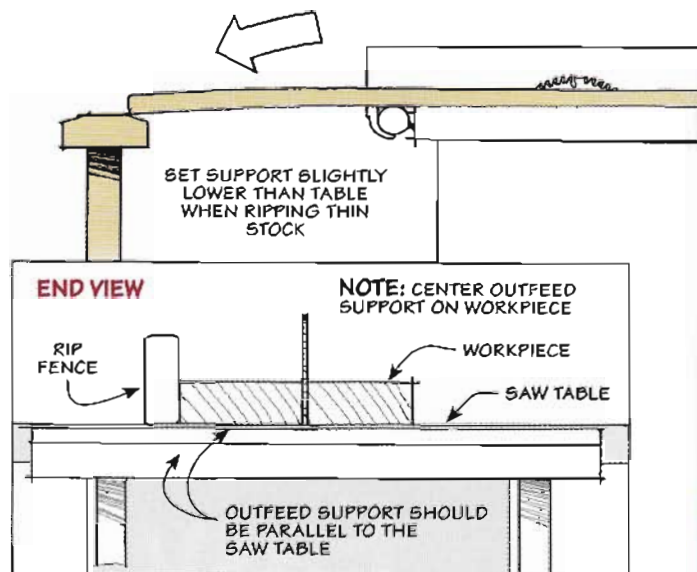

placing your outfeed support too close to the table saw.

Positioning the support to do its job from the beginning to the end of the cut is pretty easy. It turns out that the perfect support position is just a little less than half the length of the board from the back edge of the saw. You can just make a rough guess on this position, and it'll work out fine.

And now with the outfeed support carrying the load, tough rip cuts are a thing of the past.

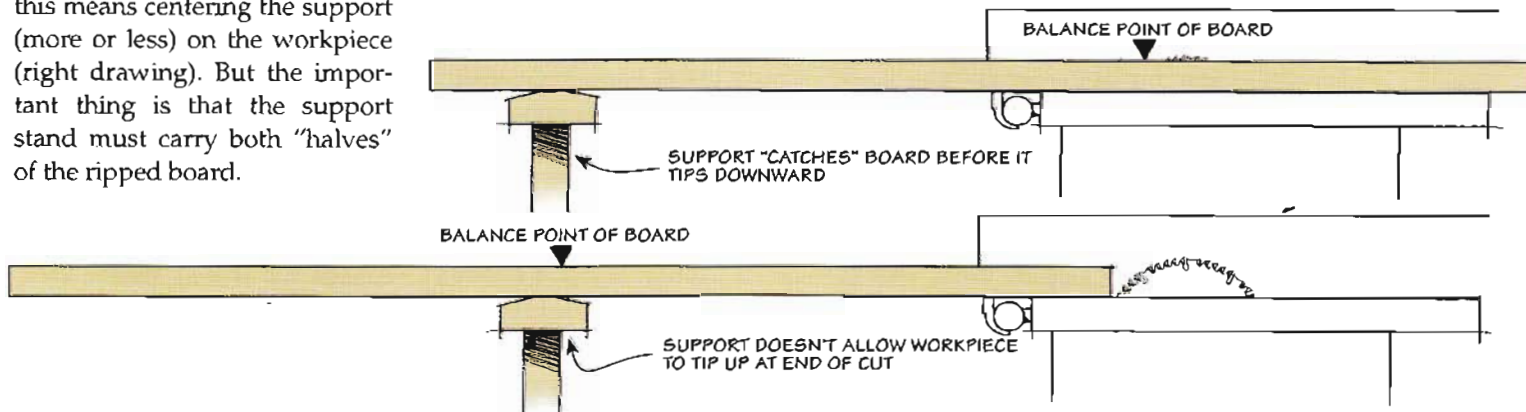

Another Helper: Infeed Support

Good outfeed support is a must for safe, accurate ripping, but there are also times when a little help with infeed support can make a cut a lot easier. When I have a large, awkward panel or board that needs to be accurately positioned for a cut, I install the simple infeed support shown in the drawing at right.

The infeed support is simply a fence extension attached to the rip fence that holds a wide support board level with the saw table. Use this along with an outfeed support stand to give yourself complete control — before, during, and after the cut.

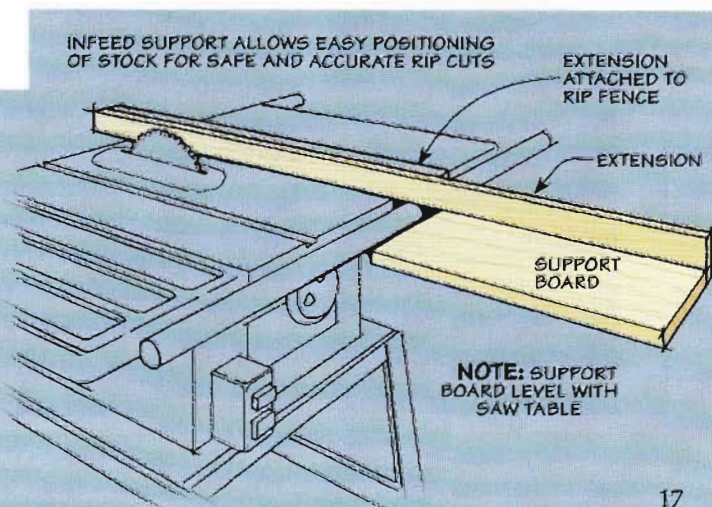

Easy Maintenance for your Saw Blades

For better cuts and longer life, it makes good sense to take the best possible care of your table saw blades.

1 Removal & Installation

If you're like me, you have quite a bit of money invested in high-quality, carbide-toothed table saw blades. To ensure they always give top-notch results, you need to care for them properly.

For the most part, this is pretty simple stuff. And it starts with the basic job of removing and installing a blade without damaging the brittle, carbide teeth. This is easy to do when you follow the routine explained here.

To remove a blade, I first lower it completely below the surface of the saw table. This allows you to easily remove the throat insert plate without bumping it against the teeth, as shown in photo 'a.'

With the throat opening clear, you now want to raise the blade to give yourself better access to the arbor and arbor nut. Next, use a sturdy scrap to gently "jam" the teeth of the blade and prevent it from turning while

you loosen the nut, as shown in photo 'b.' Notice that I added a "bend" to the shaft of the arbor nut wrench (photo 'c'). This keeps both the wrench and your hand away from the teeth.

After removing the nut and washer, carefully grab the blade with both hands and slowly work it off of the arbor shaft (photo 'c'). It may take a back and forth "wobble" to move it along. When you reach the end of the shaft, gently ease the blade free and lift it out of the throat opening. Note: If the blade isn't going straight into storage, be sure to set it on a "soft" surface.

When you install a blade, you simply reverse the order of the steps. But note that to tighten the arbor nut, you'll need to jam the blade from the back of the saw. And try not to overtighten the arbor nut, a light torque is all it takes. Finally, lower the blade, replace the throat insert plate, and your saw is back in business.



2 Keep It Clean

A blade that's free of pitch and resin buildup will produce cleaner cuts and stay sharp longer. So for me, regular cleaning is a must when it comes to saw blade maintenance.

For a long time, caustic oven cleaner was recommended for the job. Today there are less harmful options (refer to the article on page 20). The idea is to spray both sides of the blade with cleaner and then give it five or ten minutes to work. The lid from a plastic five-gallon bucket makes a good tub (main photo at right).

Once the cleaner has done its job, all it takes is a little work with a non-abrasive scrub pad to remove the residue. A brass-bristle brush will make quick work of cleaning hard-to-reach spots on the teeth and in the gullets (main photo at left). When all you see is a bright, shiny surface, rinse the blade with water and dry it off to prevent rust.

And finally, to reduce the friction that increases pitch and resin buildup, I complete the job by spraying the blade with a coat of lubricant (inset photo at right).

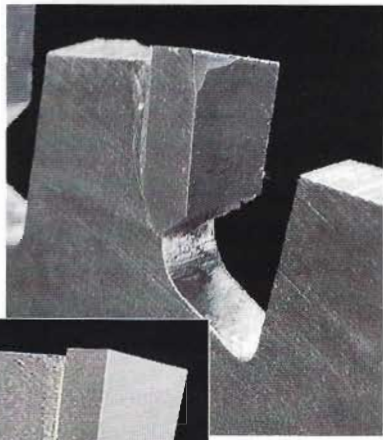

▲ BEFORE

◀ AFTER

3 When Do I Sharpen?

It can be hard to know when a blade needs to be sharpened. But there are a couple of indicators that help remove the guesswork.

The most obvious sign is a poor-quality cut. If you're getting rough cuts and burning from a clean blade on a well-tuned saw, dull teeth are the likely culprit.

The second clue comes from a close inspection of the carbide tips under good light. All the edges and corners (beveled tips) should look sharp and crisp.

A reflective line along the edges means they're getting rounded. And keep an eye out for minor chips, like you see in the main photo at left. Even a dull blade can feel sharp (and cut you), so I never judge with my fingers.

If your blade fails the tests, it's time to consider spending \$15 to \$20 for a professional blade sharpening. On the plus side, the blade will come back with razor-sharp teeth that cut like new (inset photo at left).

4 Safe Storage

Storing your blades safely is a simple, but important, component of a long, sharp blade life. The key is to keep the blades (especially the teeth) away from damaging surfaces and away from each other, but still within reach. A simple wall rack, like the

one in the photo at right, is the best answer that I've found.

Each blade has its own protective slot in this compact, plywood rack. The slots (cut with a jig saw) are widely spaced to make inserting or removing a blade safe and easy (drawing below).

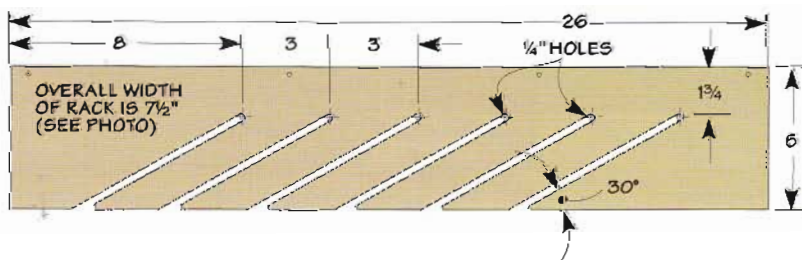



Choosing & Using Blade Cleaners

You can bring new life to your saw blades with a surprising range of cleaning products.

Just like any other tool in the shop, saw blades get dirty. The result can be ragged cuts and burned edges. But the solution to these problems is often just a simple cleaning.

All kinds of products are available for cleaning saw blades, from commercial versions to home brews. But finding one that works quickly and efficiently can be a challenge. I compared several cleaners and found some that work very well and a few others that were less effective (chart on opposite page). Sources for these are available on page 98.

A WORD OF CAUTION. Before you decide on a product to use, you should know that lye-based cleaners, like oven cleaner, aren't recommended for use on carbide-tipped blades. The lye breaks down the binders used to hold the carbide together.

This causes a blade to dull more quickly and more carbide will need to be taken off during the sharpening process, reducing the life of the blade. Lye also could remove the non-stick coating and printing.

THE RIGHT TOOLS. Selecting a cleaner is just one step in the process.

To get started you'll also need something to work in. There are pans made specifically for cleaning saw blades. But several things you may already have on hand will work just as well, like the lid from a bucket of drywall mud or a clean oil pan.

You'll also need a small brass brush, a synthetic cleaning pad, and some type of rust inhibitor.

CLEANING. Now that you have all of your tools assembled, you can start work on removing the pitch and resin. Depending on the type of product you choose to use, you'll need to either spray or soak the blade.

Once the cleaner has time to react with the resin, remove the blade from the solution and scrub the surface with a synthetic pad. A synthetic pad will help remove resin from saw blades, but won't remove metal like steel wool does. If any resin remains, use the brass brush to remove it.

If the cleaner is oil-based, you can remove the excess with a



Before. Resin builds up on the shoulders and gullets of a blade, as well as the cutting edge.



After. A good cleaner will remove resin without much scrubbing with a brush or pad.



Apply Cleaner. Use a clean oil pan or other flat plastic pan to soak the blade in the cleaner.



Elbow Grease. A brass brush is handy for cleaning the shoulders and gullets of accumulated resin.



Protect. Be sure to apply rust inhibitor to surfaces cleaned with water-based cleaners.

soft cloth. But some of the cleaners listed need to be rinsed off with water, in which case a rust preventive should also be used.

TOP PICKS. After testing several cleaners, I found that some work better than others. *Extreme Simple Green* is an earth-friendly product made by the folks at *Simple Green*. It was developed to clean aircraft, so it won't damage or corrode metal. You can safely soak blades in the full-strength solution without

breaking down the carbide. Plus, it's biodegradable.

Lestoil cleaned the blade in the main photo on the opposite page without scrubbing in just five minutes and at a low cost. But it contains a strong solvent. The thing to be aware of here is that the cleaner is not biodegradable. If you decide to use *Lestoil*, it can be reused until it becomes cloudy. But you'll need to rinse blades in water and collect the waste for disposal at your local collection

center for household waste. If it wasn't for this one thing, I'd use *Lestoil* without hesitation.

Rockler Pitch and Resin Remover also worked well at removing resin. And *Rockler* offers a complete kit with the large-sized cleaner that includes a brass brush, a pan for blades, and a small plastic jar for cleaning bits.

Once you find a cleaner that works for you, I think you'll find it's a quick and easy way to improve blade performance.

USAGE NOTE

While the original *Simple Green* is a good option for cleaning most of your blades, the manufacturer warns it should not be used when cleaning carbide-tipped blades. The contents of the cleaner cause the carbide to leach from the metal.

Brand	Lestoil	Extreme Simple Green	Rockler Cleaner	Baking Soda	Goof Off	CMT Blade & Bit Cleaner
Ingredients	Stoddard Solvent (white spirits) Oil based	Contains no harmful chemicals Water based	Citrus Oil Water based	Sodium Bicarbonate Water based	Xylene, Toluene Oil based	Butoxyethanol Water based
Cost per use	\$\$	\$\$\$\$	\$\$	\$	\$\$	\$\$
Amount used	7 oz.	16 oz.	4 oz.	2 oz.	3 oz.	3 oz.
Speed	5 minutes	15 minutes	10 minutes	8 hours	30 minutes	30 minutes
Ease of Use	<ul style="list-style-type: none"> • Resin removed without effort • Use full strength • Water rinse • Can be reused 	<ul style="list-style-type: none"> • Resin removed without effort • Use full strength • Water rinse 	<ul style="list-style-type: none"> • Resin removed with little effort • Mix 1/3 cleaner with 2/3 water • Water rinse 	<ul style="list-style-type: none"> • Resin removed with little effort • Mix 1/4 cup with 1 qt. water • Water rinse 	<ul style="list-style-type: none"> • Resin removed from flat surfaces • Gullets didn't get as clean • Spray on 	<ul style="list-style-type: none"> • Resin removed from flat surfaces • Gullets would not scrub clean • Spray on
Comments	<ul style="list-style-type: none"> • Not biodegradable • Collect for disposal at collection center for household waste • Safe for all metals 	<ul style="list-style-type: none"> • Biodegradable • Safe for all metals • Leaves residue 	<ul style="list-style-type: none"> • Need wire brush to remove resin from gullets • Safe for all metals • Biodegradable 	<ul style="list-style-type: none"> • Inexpensive and handy • Longer working time • Safe for all metals • Biodegradable 	<ul style="list-style-type: none"> • Slow working time • Not biodegradable • Rust inhibitor • Safe for all metals 	<ul style="list-style-type: none"> • Slow working time • Left resin in the gullets that would not scrub out • Safe for all metals



120 vs. 240 Volts Motor Wiring

Is there an advantage to running your power tools at 240 volts? Here's what you need to know to decide what's right for you.



240 Volts. This 20-amp receptacle will accept 15-amp or 20-amp plugs

If you ask a woodworker about which voltage is better for the motors on stationary power tools (120 or 240), you're likely to get some strong opinions. Some say it doesn't make any difference. Others swear that their motors are more powerful since they made the switch to 240 volts. A few will tell you that you'll save money on your utility bill by switching your tools over to 240 volts. So what's the truth? Read on to find out which option is best for your shop.

SHOP WIRING. One of the first things in determining the best voltage for your tools is your shop wiring. If your shop already has 240-volt circuits available, you'll find receptacles like the one shown at left.

But if your shop is like mine, there are only 120-volt circuits. So the decision comes down to a few other factors.

ELECTRICAL WORK. When thinking about adding circuits in my shop, I like to rely on the help and advice of an electrician. He can tell you if your breaker box can handle the additional load and required breakers. He'll also help you decide which type of cable is needed and how to install it.

MOTOR LABELING. Besides the shop wiring, there's the issue of whether your tools can run at 240 volts. Looking at the nameplate or label on most power tool motors (top of the next page), you may see a reference to two voltages, in this case "120/240." This designation means the motor can be wired for either voltage.

Note: The voltage listed on a motor is the nominal voltage it's rated to run at. You'll see references to 110/220, 115/230, or 120/240. But when referring to household or residential voltage, "120/240" is an accepted term.

MAKING THE DECISION. Once you've determined whether or not the motor is capable of running at 240 volts, you have to decide if it has any benefits for you. I contacted a friend who's an electrician to help me out. Without getting into a technical discussion, he gave me some valuable information.

SAVING MONEY? The first thing to get straight is that you won't save a nickel on your utility bill by converting your motors to run at 240 volts. The total power used by the motor is the same at 240 volts as it is at 120 volts.

MORE POWER? Here's something else that surprised me. The motor doesn't actually develop any more muscle at 240 volts. The horsepower rating on most motors is the same at either voltage.

DUAL RATING. After clearing up these misconceptions, it's good to know there are some benefits to making the switch to 240 volts.

SAFETY NOTE

If you are not comfortable performing electrical work, consult with a licensed electrician.

This designation means the motor can be wired to run at either 120 or 240 volts.

The amperages tell you the amount of current draw at low voltage/high voltage.

HP	1 1/2	RPM	3450
VOLTS	120/240	AMPS	12.8/6.4
HZ	60	PH	1
SERVICE FACTOR	1.0	ENC.	-DP
INSUL. CLASS	3	FRAME	56
TIME RATING	CONT.	TYPE	B
DESIGN LETTER		KVA CODE LETTER	H

The first is the fact that your tool's motor might be "dual-rated." The motor could be designed to run with more horsepower at a higher voltage. If this is the case, you'll see two horsepower ratings on the motor's label. For example, 1.5/2.0. In this case, you would see a 33% increase in power by converting to 240 volts.

HIGH AMPERAGE DRAW. If the lights in your house dim when you turn on the table saw, you'll see an improvement by converting to 240 volts. The lights dim because of the high draw of starting current required by the motor. Using 240 volts reduces the operating current with a side benefit of reducing the startup current.

RULES OF THUMB. When it comes to electricity in the shop, the first recommendation is to put your tools on a 20-amp circuit if possible, regardless of the voltage. But it's because of the startup load that it might make sense to

convert to 240 volts. That will depend on the full-load amperage draw shown on your motor's label. If the motor is rated over 16 amps at 120 volts and you have the option, go ahead and make the switch to 240 volts.

MULTIPLE TOOLS. If you're like most woodworkers, you probably run a dust collector and a major tool like a table saw or planer at the same time. Here, it makes sense to operate them at 240 volts, if possible. There's not enough capacity on a 120-volt circuit, even at 20 amps, to handle the load of both motors at the same time. (Your electrician can help you calculate the load of your tools and type of circuits required.)

MAKING THE SWITCH. Once you've decided to switch to 240-volts, you'll need to move a couple of wires on the motor. Your motor should have a diagram to help you out with this. You can see a sample diagram below. As you

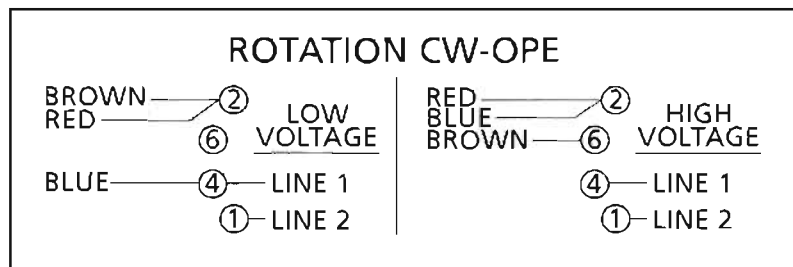

Wiring Diagram. A label on your motor or a diagram in your owner's manual will show you how to switch the wiring for 240-volt use. After that, you'll have to install the appropriate plug on the tool's cord.



Plug Change. When converting a motor to 240-volt operation, you'll need to change the plug on the cord, as shown below.

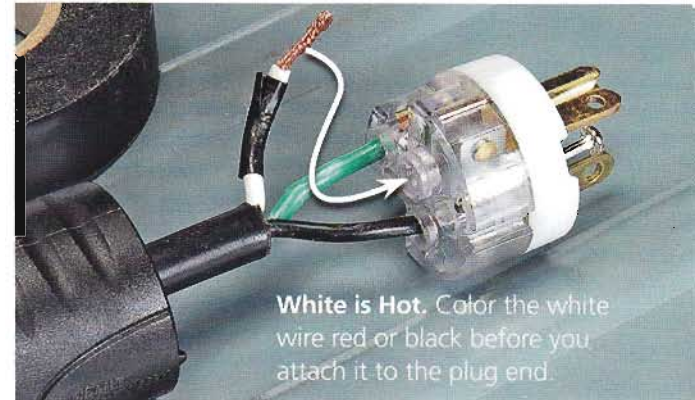

White is Hot. Color the white wire red or black before you attach it to the plug end.

can see in the photo on the opposite page, the wires can be found behind a plate on the motor.

The next thing to do is change the plug to a 240-volt plug, like you see in the photo above. When you do this, you should color the white wire black or red to indicate it's a "hot" wire.

EXTENSION CORD. Chances are, your power tool won't always be near a 240-volt outlet. But with a pair of cord ends (plug and receptacle), you can make your own extension cord (photo below).

As you can see, once you decide it's the right move, converting your tools to 240 volts is easy.

Extension. You can easily make an extension cord for your 240-volt tools.

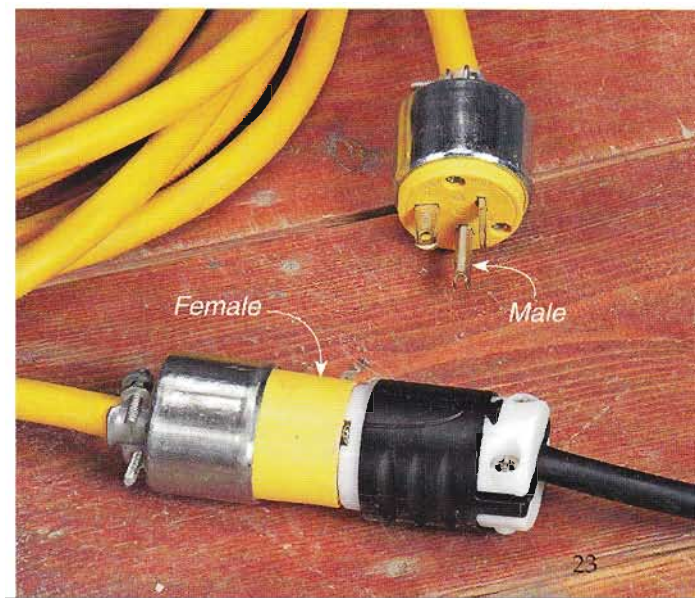

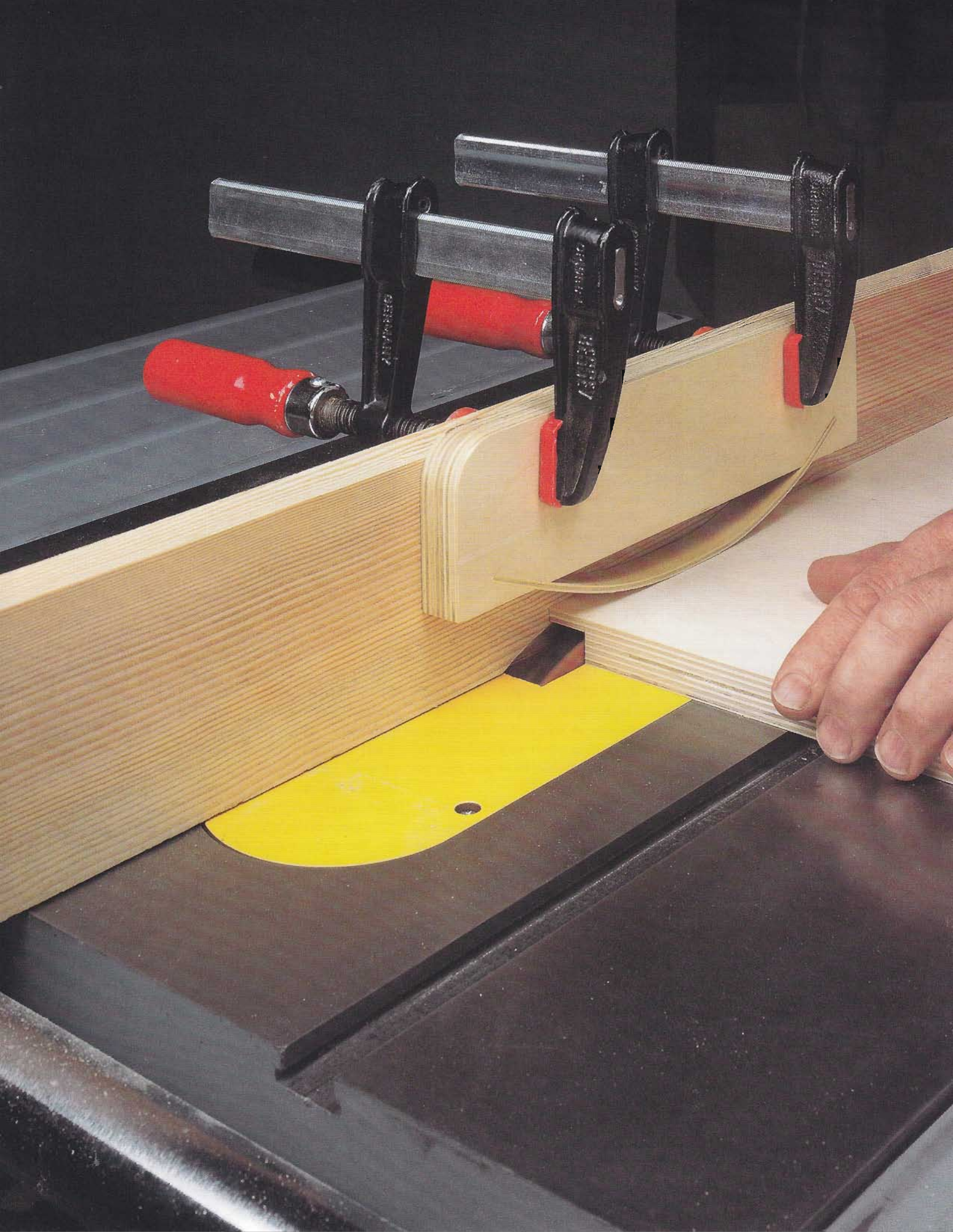

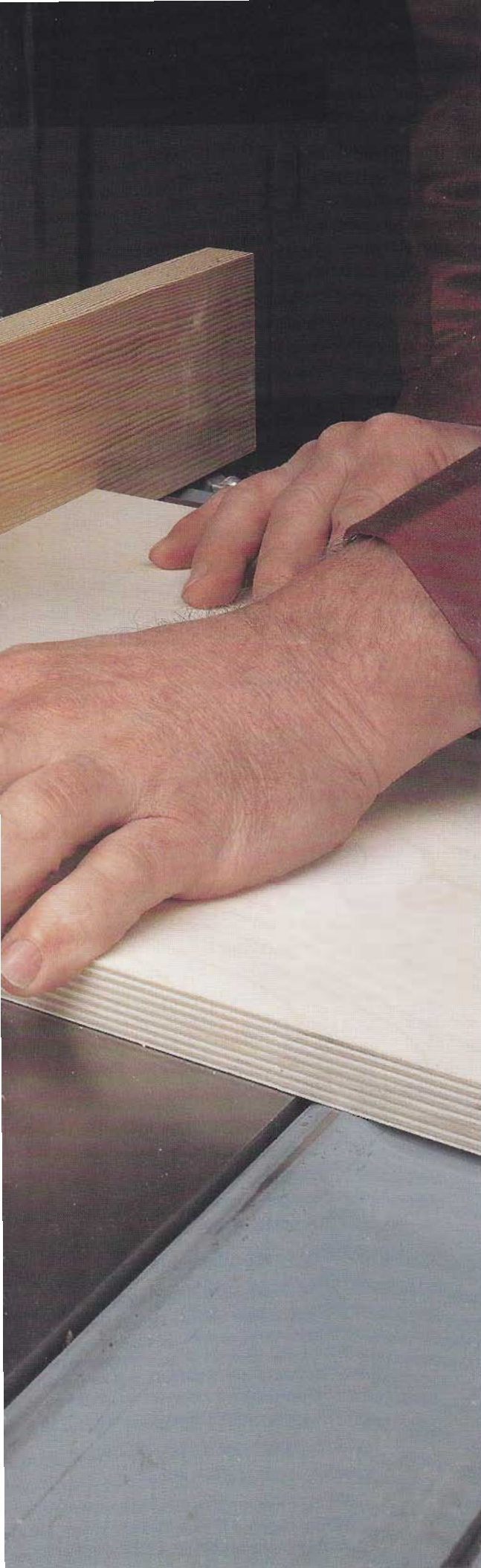

Essential Joinery

Mastering joinery on the table saw is easier than you might think. Here, we'll break down the steps for each individual cut so you're sure to end up with perfect-fitting, sturdy joints.

DEAD-ON DADOES26

TONGUE & DADO JOINERY28

RABBETED CASES32

TOP-NOTCH TENONS34

STUB TENON & GROOVE JOINERY ..38

Dead-On Dadoes

With the right setup and a few, simple techniques, you'll be cutting perfect dadoes every time.

A stack dado set is the standard tool for cutting grooves, rabbets, and dadoes on the table saw in my shop. Unfortunately, it doesn't always yield results that meet my expectations. The key to getting better results with your dado blade involves understanding how it works. Once you've got that down, you just need to know the best ways to set up, lay out, and cut your dadoes.

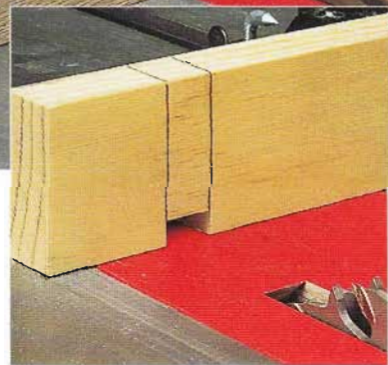

SETUP. The first step is properly setting up a dado blade. And to do this, it's a good idea to understand how it works. As you can see in the drawing below, a dado set consists of a pair of scoring blades and several chippers.

The scoring blades are the outer blades that resemble standard saw blades. You'll find that the difference is their teeth are angled either left or right to cut crisp outside edges for the dado (detail drawing below).

Sandwiched between the outer blades are the chippers. These are designed to clean out the waste left between the scoring blades. They come in different

Notch It. The notch in this auxiliary miter gauge fence pinpoints the dado location on the workpiece.

widths and can be combined to create a variety of dado widths.

When installing a dado blade, remember that you need to stagger the teeth of the chippers. This prevents them from touching each other and being damaged. It ensures that all the plates are flat against each other and the arbor nut can be securely tightened.

DADO SET

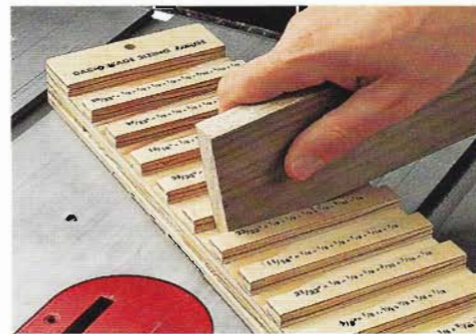
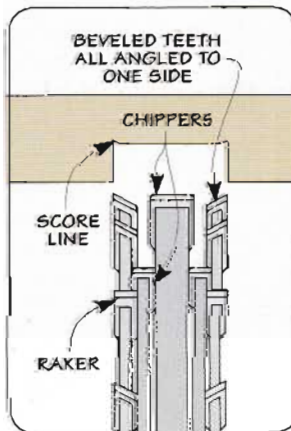
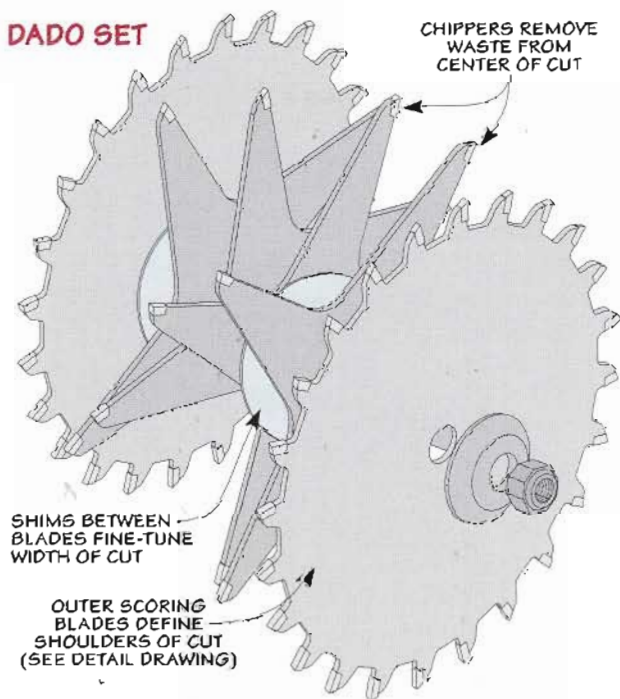

Dado Blade Gauge. This shop-made guide determines which blades and chippers are needed to make the perfect-sized dado.

SIZING GAUGE. To speed up the process of sizing a dado blade, I made the gauge pictured at the bottom of the opposite page. Just slip your workpiece in the dado that fits to know the "recipe" of blades and chippers it takes to make a dado that size. Now, it takes just a few seconds to put the right parts together to accurately size the blade and dado.

If the dado is still a hair undersized, you can use shims to tweak the final width. And for the best results, place the shims evenly throughout the stack.

POSITIONING. With the sizing and setup complete, the next step is cutting the dado in the right place. Leaning over the table saw to accurately align the layout lines with the dado blade can be

a challenge. For better results, I like to cut a notch in an auxiliary miter fence and draw layout lines on the fence to show the edges of the cut (detail photo on the opposite page). To prevent tearout, the notch in the auxiliary fence is the same depth as the dado.

Next, I mark the edges of the dado on the workpiece (main photo, opposite page). Then, line everything up and make the cut. (For other ways to reduce tearout, check out the box below.)

HANDY TECHNIQUES. This process works great for most dados. But centered and matching dados call for different techniques.

Centering a dado is a simple two-pass process (upper right drawing). Once you've finished the second pass, the dado is

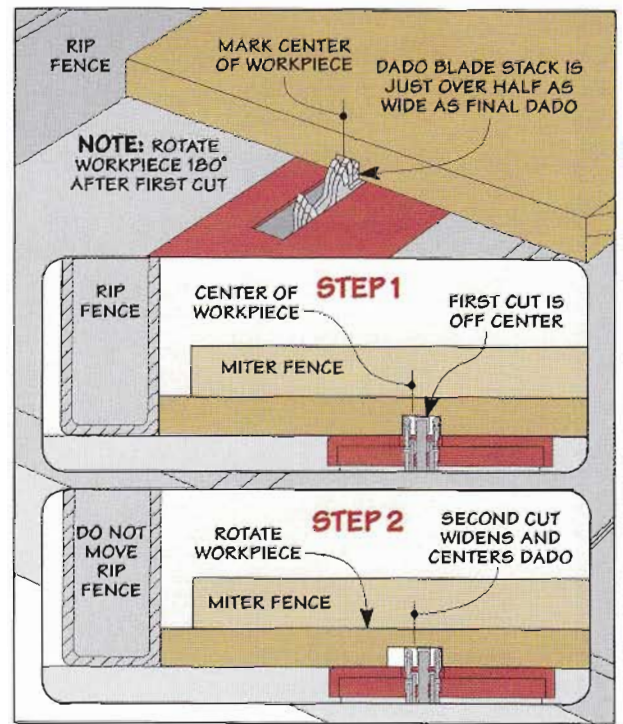

automatically centered on the workpiece. However, it may not be the correct width. To get the right width while keeping the dado centered, you can sneak up on it by readjusting the rip fence and repeating the procedure.

For matching dados in small projects, I like to start off with an extra-wide workpiece (left photo). After ripping the workpiece to final width (inset photo), the dados will match perfectly.

So, you can see that a dado blade is a must-have table saw accessory. And with these simple techniques, you can be sure you'll get crisp, precise cuts every time.



Matched Dados. After carefully cutting the dados, ripping the workpiece to final width provides perfectly matched dados.

Tips & Tricks: Avoiding Tearout

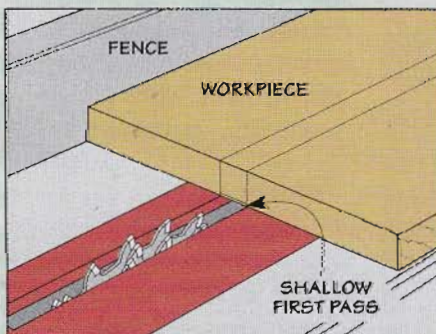

Shallow Cut. To cut clean shoulders, make a shallow scoring pass before cutting the dado to full depth.



Tape Reinforcement. Press masking tape firmly onto the workpiece to reinforce the wood for a chip-free cut.

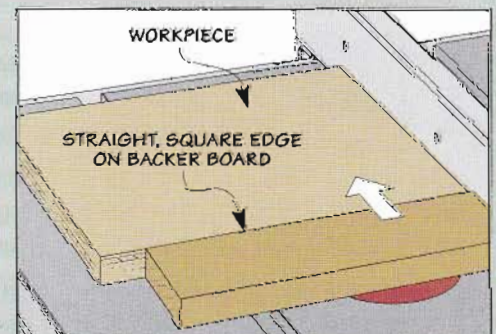

Back Up the Cut. A backer board is a simple way to prevent tearout at the edge as the dado blade exits the cut.

This versatile joint makes it easy to create strong and sturdy cases and drawers.

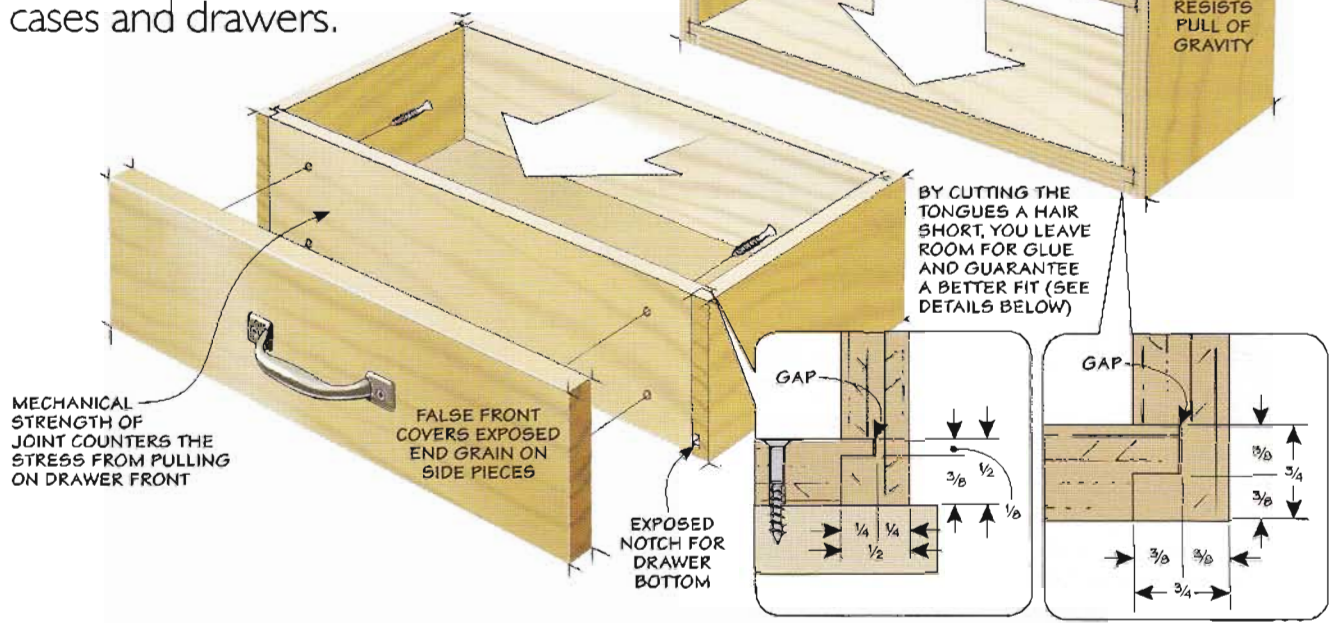

Essential Joinery: Tongue & Dado

When I'm building a case, I want the joinery to be both strong and easy to make. A tongue and dado joint is a good option for a couple reasons: The interlocking parts make aligning the case pieces during assembly a snap. And it provides a good amount of glue surface for a sturdy connection.

CASES & DRAWERS. Another benefit of this joint is that, with a few adjustments, it works equally well on drawers. The drawings at the top of the page give you a good overview of how the joint works in both instances.

A dado is cut near each end of the case sides (or drawer sides),

as shown in the lower left photo. Then a mating tongue is cut on the case top, bottom, and shelves (or drawer front and back), as you can see in the right photo below. There's a simple reason for this arrangement.

In the wall cabinet you see in the drawing above, the joinery resists the pull of gravity. In a drawer, the joints need to stand up to the repeated tugging on the drawer front. In both cases, the interlocking nature of a tongue and dado joint fills the bill.

EXPOSURE. But there are a couple drawbacks to this technique. With a plywood case, the top and bottom reveal exposed ends.

With drawers, there are two problems. The first is that the end grain of the sides is exposed at the front. And the second is that



◀ **Dado First.** The first half of the joint is a dado cut near each end of the side pieces.

Rabbet to Fit. ▶ The other part of the joint is a rabbet that creates a snug-fitting tongue for the dado.



Shop Tip: Removing Tearout

you typically see a notch from the groove for the drawer bottom.

The obvious solution for a case is to hide it with a top. And for a drawer, you can add a false front. Yes, this does add an extra step. But it's worth considering when you're designing a project.

Now that you have a good idea of the basics of a tongue and dado joint, the next step is mastering how to cut it accurately.

CUTTING THE JOINERY

I have a few goals when creating a tongue and dado joint. First of all, when it's assembled, the ends of the case sides should be flush with the top and bottom. And the two pieces should fit together with hand pressure.

Finally, the tongue should almost, but not quite bottom out in the dado. This provides extra space for glue, but more importantly, it allows the shoulder of the joint to close tightly. All this should add up to a case (or drawer) that's square and solid.

Note: For this process, I'll refer to making a case out of $\frac{3}{4}$ " plywood. You can find details on making drawers on page 31.

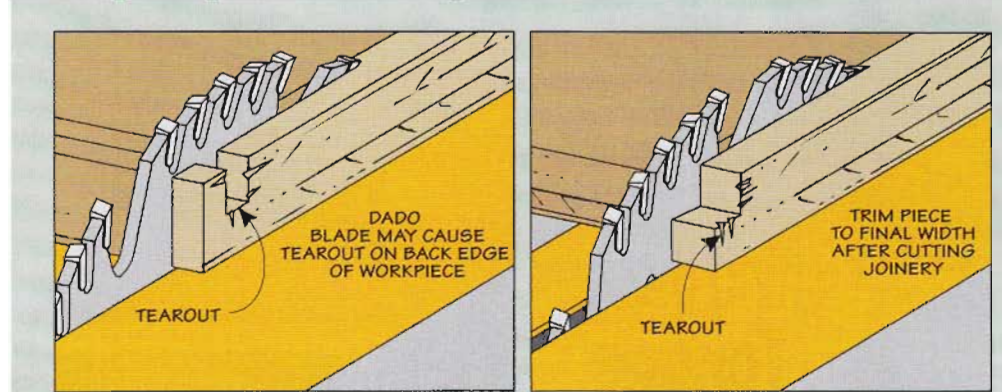

Eliminate Tearout. Cutting dados and rabbets can lead to tearout on the trailing edge of the workpiece. One way to avoid this is to use a backer board to support the edge. But often, it's easier to cut the case panels a bit wider than I need. Then when I'm finished cutting the joinery, I can trim the panels to size and cut away the tearout.

CREATING THE DADO. Creating a tongue and dado joint can be neatly broken down into two steps — making the dado and then cutting the tongues to fit.

I like to start by cutting the dado. I find it's easier to adjust the thickness of the tongue and sneak up on a good fit than trying to change the width of the dado.

There are three things to consider when cutting the dados: location, width, and depth.

As I mentioned earlier, one of my goals is making sure the assembled joint is flush on the end. So accurately locating the dado in the side is key. Of course, it's a good idea to make a few test cuts. But to get the fence position in the ballpark, I use a mating piece (or cutoff) as a set-up gauge, as shown in Figure 1.

WIDTH. At first glance, it would seem like any width dado would work. But there's a catch. The dado creates a short grain section that can be easily broken if the joint is stressed. So the idea here is to keep this piece as long (wide) as possible. When working with $\frac{3}{4}$ " plywood, a $\frac{3}{8}$ "-wide dado is a good choice.

DEPTH. The last thing to think about is the depth of the dado. You don't want to compromise the strength of the sides, so the dado should be no more than half the thickness of the sides ($\frac{3}{8}$ ").

CUTTING THE DADO. When you're ready to make the cut, you want to make sure the dado is a consistent depth. To do this, I attach a featherboard to the rip fence, like you see in Figure 2.

One more thing, since this is a crossgrain cut, tearout can be a problem. Check out the box above for an easy way to eliminate it.

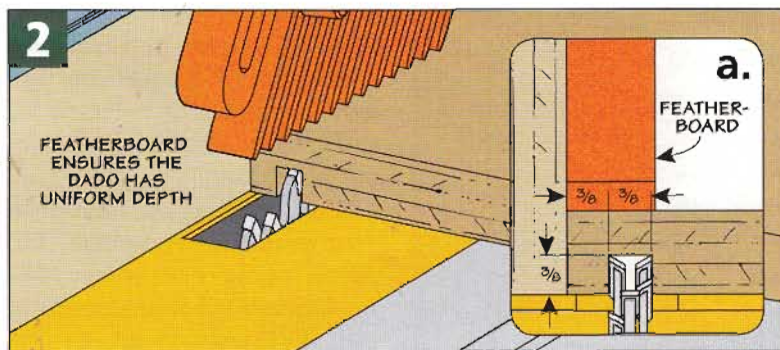
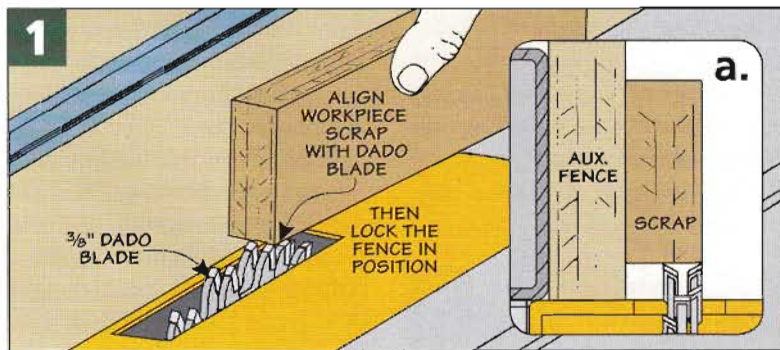



Perfect Fit. You know it's right when the joint fits tight and the ends are flush.

Cutting the Tongue

Once you've finished cutting the dados on all your workpieces, it's time to turn your attention to cutting the other half of the joint — the tongue.

It sounds simple enough, but this process is a little more involved than cutting the dados. Remember the goals I mentioned earlier. The tongue should slide easily into the dado without any slop. And the shoulder of the joint needs to close up tight.

SAW SETUP. The first thing you'll need to do is change the setup of the table saw. Start by installing a dado stack that's wider than the final length of the tongue.

Then attach an auxiliary rip fence. This allows you to bury the blade in the fence to "dial in" the exact length of the tongue.

Just like when you cut the dados, it's a good idea to attach a featherboard to keep the thickness of the tongue consistent.

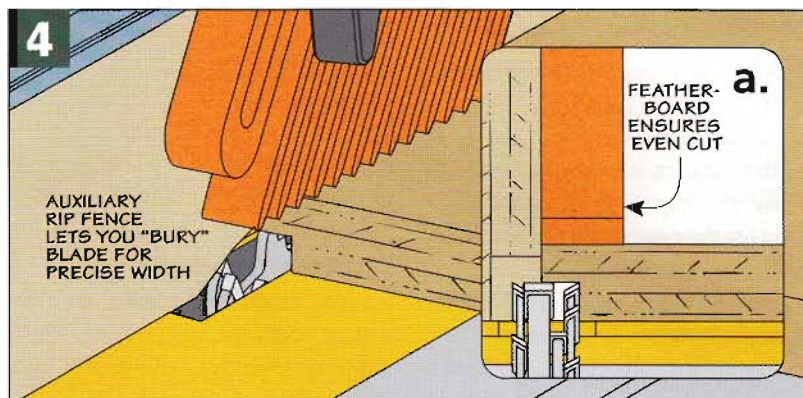
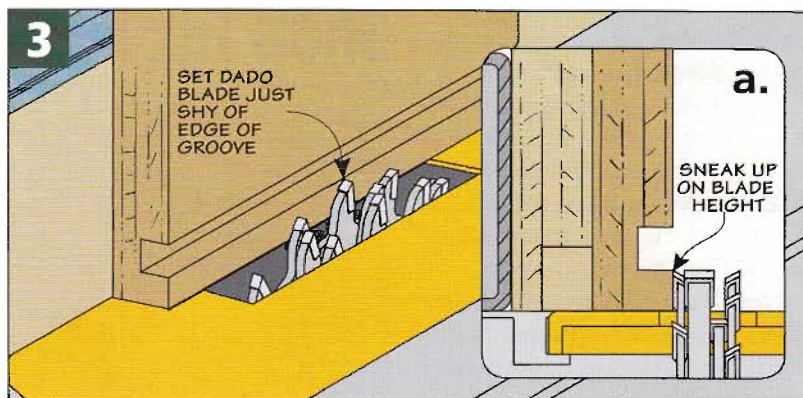

That takes care of the initial setup. Now you can focus on fine-tuning the setup for the cut. This involves two things — setting the blade height and establishing the width of the cut.

BLADE HEIGHT. The height of the dado blade should create a tongue that just fits in the dado. Once again, making some test cuts is the way to go. But you can eyeball the height by using one of the side pieces as a gauge, as shown in Figure 3. Place a side piece on end and raise the blade

until it's almost even with the lower edge of the dado. This gets you in the ballpark.

To get the blade height set just right, you'll need to bring in the rip fence. I like to bury most of the blade and make a test cut (Figure 4). This creates a short tongue. Check the fit of the tongue in one of the dados you cut earlier, like you see in Figure 5. It will probably be a bit "fat."

Simply raise the blade a hair and make another cut. Then just repeat this process until you end up with a fit that isn't too tight.

LENGTH. With the blade height set, you can follow a similar process to adjust the length. Bump the rip fence over and make a series of test cuts. Your aim is for the shoulder of the rabbet to pull tight, as illustrated in Figure 5b, and for the tongue to not bottom out in the dado.

Finally, you can cut tongues on your remaining workpieces. The payoff is a case that goes together easily (photo above) and is sturdy enough for years of use.

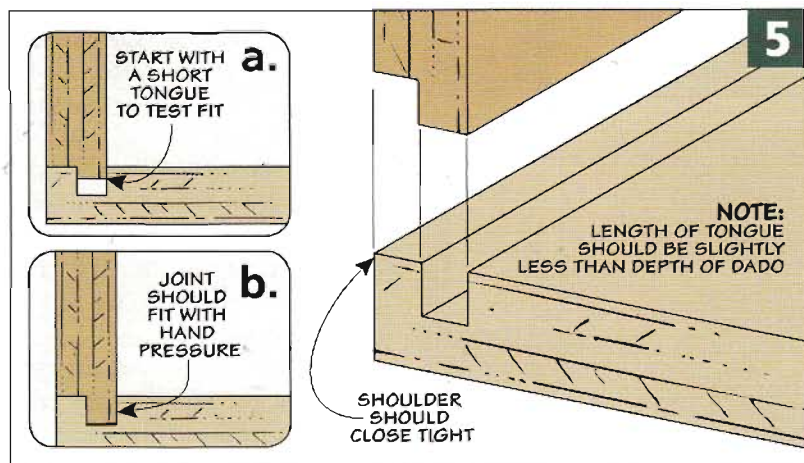

Solid-Wood Drawers

What makes tongue and dado joinery a favorite is that it's versatile enough for case construction and easy-to-assemble drawers. After all, drawers are really nothing more than small cases.

Since drawers are smaller in scale, it makes sense to scale down the joinery, too. But don't get me wrong, the joinery will still be plenty strong. In the example here, the drawer parts are made from 1/2"-thick hardwood.

Narrow Dado. Sizing the joinery starts with the dado. Instead of using a dado set, I like to use a standard combination blade. Here again, the reason is that I want to prevent the short grain section ahead of the kerf from popping off. Using a 1/8"-wide blade leaves this vulnerable section as long (wide) as possible.

If you take a look at Figure 1, you'll see that setting up for this cut works about the same as it

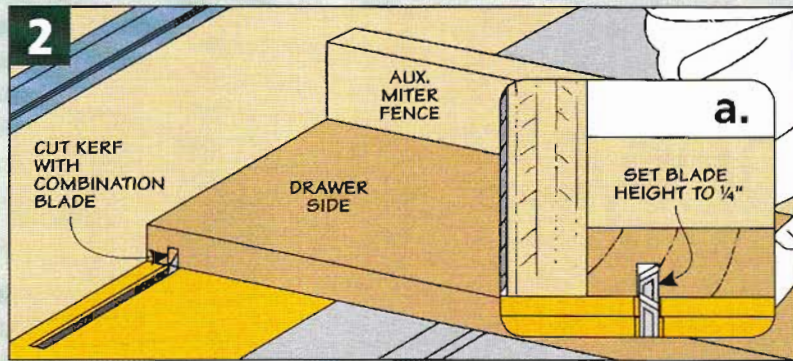
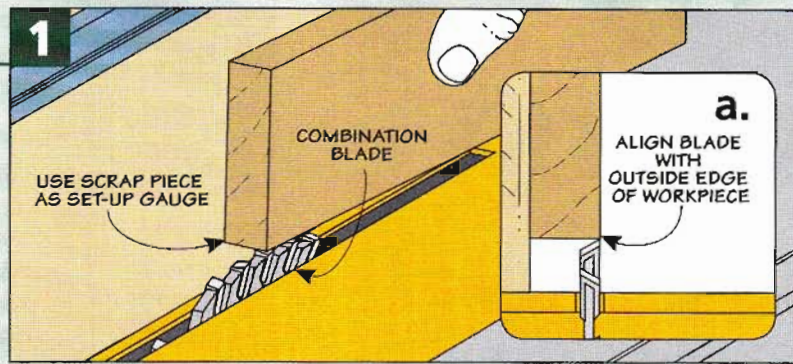

does for case construction. First, set the rip fence to align the outer edge of the teeth with the outside face of a scrap piece that matches the thickness of the drawer front or back. Then adjust the blade to a height of 1/4".

Preventing Tearout. When cutting the dados, I like to use

the miter gauge fitted with an auxiliary fence to guide the narrow drawer parts across the blade. The auxiliary fence also backs up the cut to prevent tearout, as illustrated in Figure 2.

Then as you make the cut, provide firm downward pressure on the workpiece. This keeps the dado a consistent depth.

Cutting the Tongue. Setting up for cutting the tongue is shown in Figure 3. As you can see, I replaced the single blade with a dado blade. Use the piece you just cut to set the blade height.

Now it's simply a matter of adjusting the rip fence to control the length of the tongue. Make a few test cuts until the tongue slides securely into the dado and stops just short of the bottom, like you see in the photo at right.

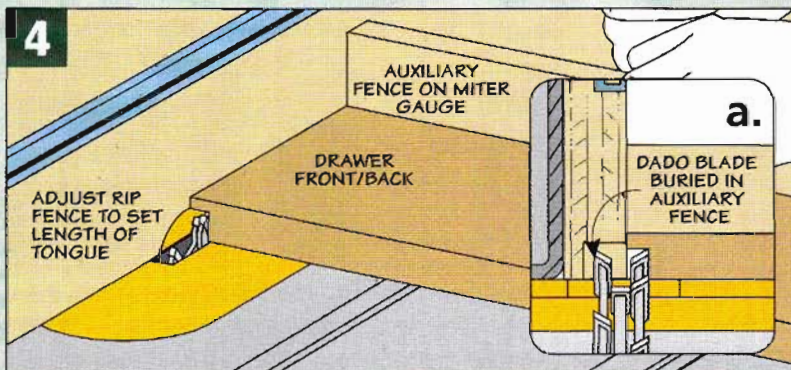
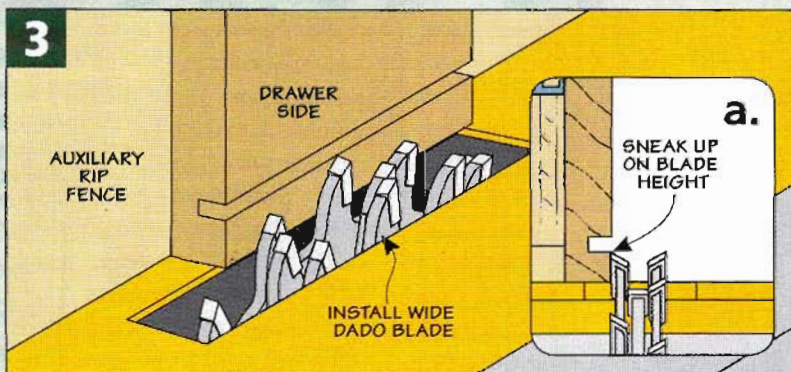

Drawer Joint. A single blade kerf provides the anchor point for the tongue in drawer construction.

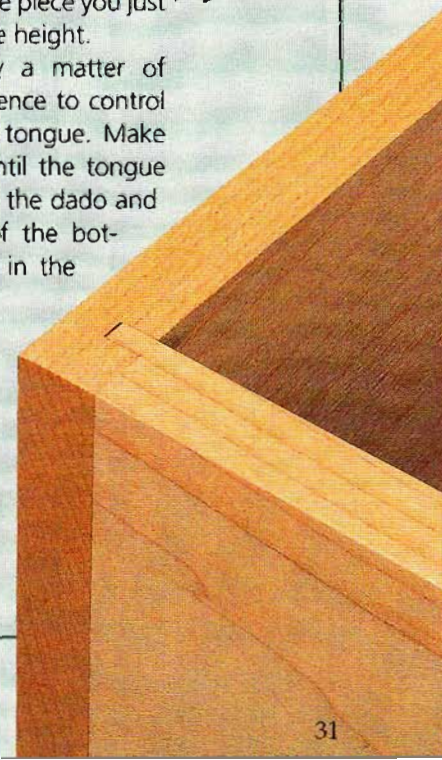

Building Cases with Rabbet Joinery

This basic method offers quick, easy, and solid construction.

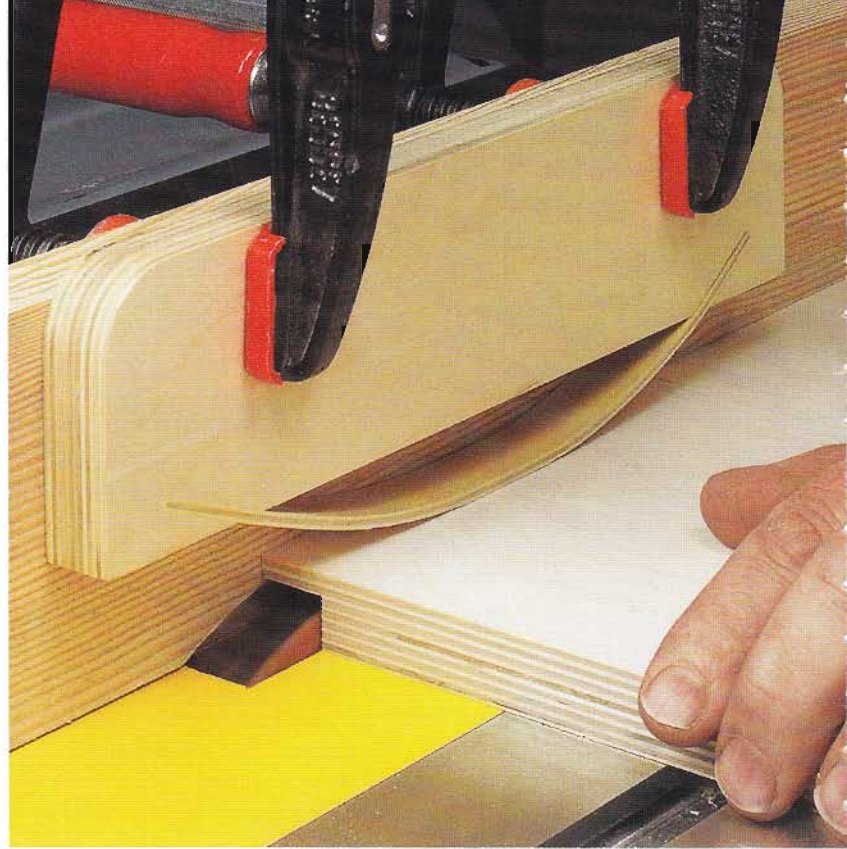

When it comes to building a sturdy case out of plywood or MDF for a shop project, basic rabbet joinery is often the best choice for the job. It's a fast way to assemble a cabinet without sacrificing strength.

WHY RABBETS? Rabbet joinery has some very basic structural benefits. First, the shoulder and the bottom of the rabbet automatically capture and align the mating pieces during assembly. The result is that the parts go together easier. Second, the "two-sided" joint creates racking resistance and a much more solid case. Finally, you have plenty of good gluing surface — and more is definitely better.

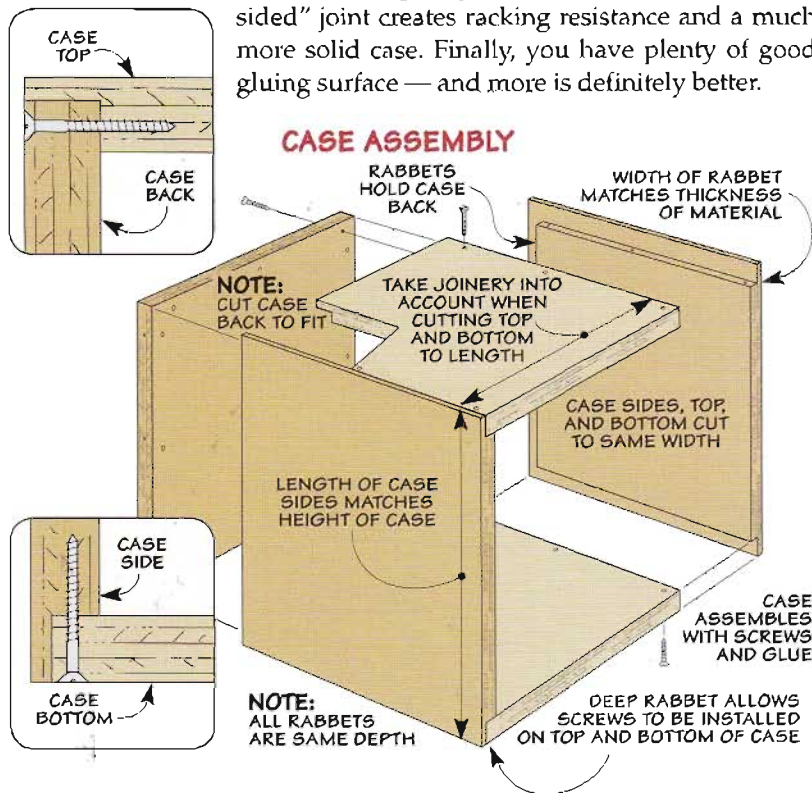

VERY BASIC. Building a case with rabbet joinery couldn't be much easier. The drawing at the lower left illustrates how the pieces all go together.

To create a four-sided box, all you need to do is cut rabbets across the ends of two opposite case pieces — most often the sides. The depth of the rabbet can vary from one quarter to three quarters of the thickness of the case piece. The width of the rabbet needs to match the thickness of the mating case piece so that the assembled joint forms a flush corner. A second series of rabbets along the back edges of the case pieces holds a back panel. This further stiffens the case and also allows you to easily attach it to a wall. Fasteners (screws work the best) and glue hold all the pieces together.

CONSIDERATIONS. Before getting to work, there are several things you'll want to think about. The first is how to size your case pieces. If the rabbets are cut on the case sides, the length of these pieces should match the height of the case (drawing at left). And to end up with a case that's the correct width,

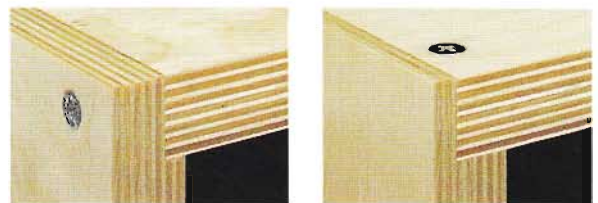

Two Good Options. The left photo shows the simplest assembly option, a shallow rabbet with screws installed through the case sides. A deeper rabbet allows you to "hide" the screws (right photo)

you need to account for the depth of the rabbets when cutting the top and bottom to length.

ASSEMBLY OPTIONS. This leads to the next point. The photos at the bottom of the opposite page show two rabbet assembly options. The left photo illustrates the more basic assembly option — a shallow rabbet with screws through the case sides pulling the pieces tightly together.

As you can see in the right photo, a deeper rabbet allows you to hide the screws on the top and bottom of the case when desired. Here, installing the screws takes a little more care, but you'll end up with a cleaner looking case.

Finally, there's one point to mention about the rabbets for the back panel. Their widths simply match the thickness of the panel, while their depths match the rabbets in the case sides. This creates a seamless assembly.

A SETUP HOW-TO. Once you've done all the advance planning and cut your pieces to size, you can set up to cut the joinery. The drawing above shows the table saw setup I rely on to take care of this job. It starts with a stack dado blade installed in the table saw. The blade should be wider than the width of the rabbets so you can make the cuts with a single pass. A zero-clearance

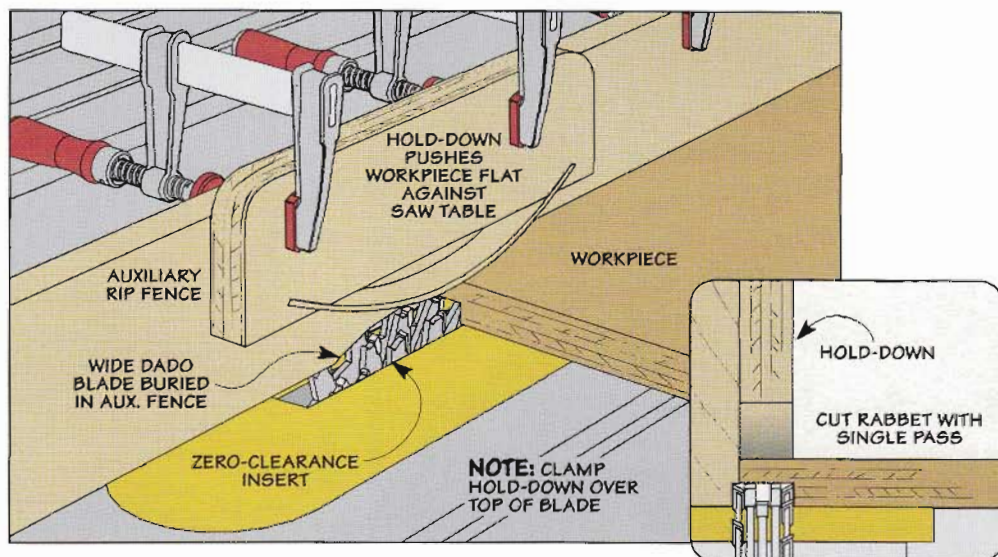

insert surrounding the blade will help prevent chipping along the shoulders of the rabbets.

As you see, the edge of the blade is buried in an auxiliary rip fence. This is how you establish the width of the rabbets and guide the cuts. Finally, a hold-down clamped to the rip fence will ensure that the depth of the cuts remains consistent.

NOW, THE RABBETS. With the table saw ready to go, the rabbets in the case sides come first. For accurate results, you'll need to carefully adjust the blade height and the position of the rip fence.

Using a separate test piece or one of your workpieces will help you with this. Start by adjusting the height of the dado blade until it cuts a rabbet of the correct depth. Then you can tweak

the position of the rip fence to get the right width.

Now, you can simply make the cuts one after the other. Your goal is a consistent depth and width. The hold-down will help keep the workpiece flat against the table for a full-depth cut. So your main focus is keeping the workpiece snug against the fence.

The rabbets for the back panel follow. You may have to adjust the rip fence to match the width of the rabbet to the thickness of the back, but otherwise the setup is the same. All four pieces need a rabbet along the back edge.

That's it for the joinery. Now all that stands between you and a sturdy case is a tight, square assembly. The box below will give you a few helpful pointers on this.

Rabbet Joinery Assembly

Once the joinery is cut, the final task is to put all the pieces together into a solid case. The process is shown in the drawings at right.

Glue alone would work, but I like to reinforce the assembly with a few screws. So the first step is to dry assemble the case and drill pilot holes for the screws.

As you can see, clamps spanning all four sides are used to pull the joints tight. Cauls placed on the case top and bottom ensure

that the clamps pull these pieces snug to the rabbet shoulders.

The cauls are placed back from the edges to allow access to drill countersunk pilot holes, as shown in the detail. A screw installed every 6" to 8" should do the job.

Now you can take the clamps off, add glue to the joints, reapply the clamps, and install the screws. And finally, the case can be flipped over to allow the back to be glued and screwed in place.

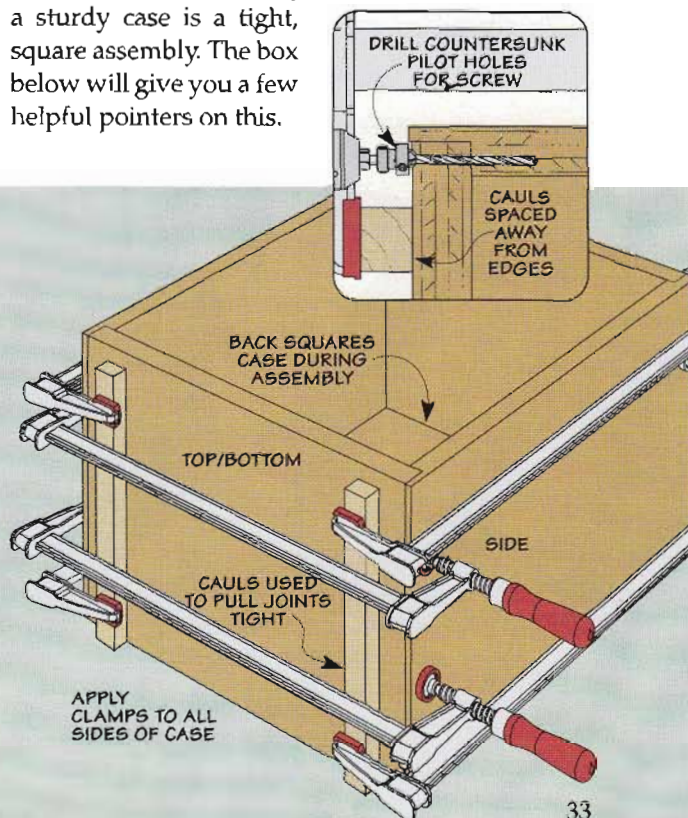

Top-Notch Tenons.

A tenoning jig and a step-by-step approach make quick work of creating tenons on the table saw.

The mortise and tenon joint is my "go-to" joint. The ample gluing surfaces and mechanical strength that it provides make it ideal for a wide range of projects.

Since I use this joint so often, my process is pretty routine. I cut the mortises first, then the tenons. This means that "the make it or break it" part of the task is cutting the tenon to fit snugly into the mortise. So I always use a tenoning jig (photo below).

ADVANTAGES. Most commercially made tenoning jigs have some real advantages over shop-built versions. They're made out of cast iron, so they'll last a lifetime without warping or going out of square. They can also be adjusted quickly and easily. Finally, the weight and mass of commercial jigs makes them solid and stable, meaning that you'll get smooth, accurate cuts every time.

ANATOMY. There are a number of commercial tenoning jigs available, but most of them are built with the same basic design. The tenoning jig is really nothing more than a tall, wide fence that holds the workpiece perpendicular to the saw table and parallel with the saw blade.

This fence slides on top of a solid base, so it can be adjusted to cut different tenon thicknesses and widths. And a runner on the bottom of the base allows it to travel in either one of your table saw's miter gauge slots.

FEATURES. The photo at left shows you a few of the typical features included on these tenoning jigs. All of these jigs have a beefy, built-in clamp that holds the

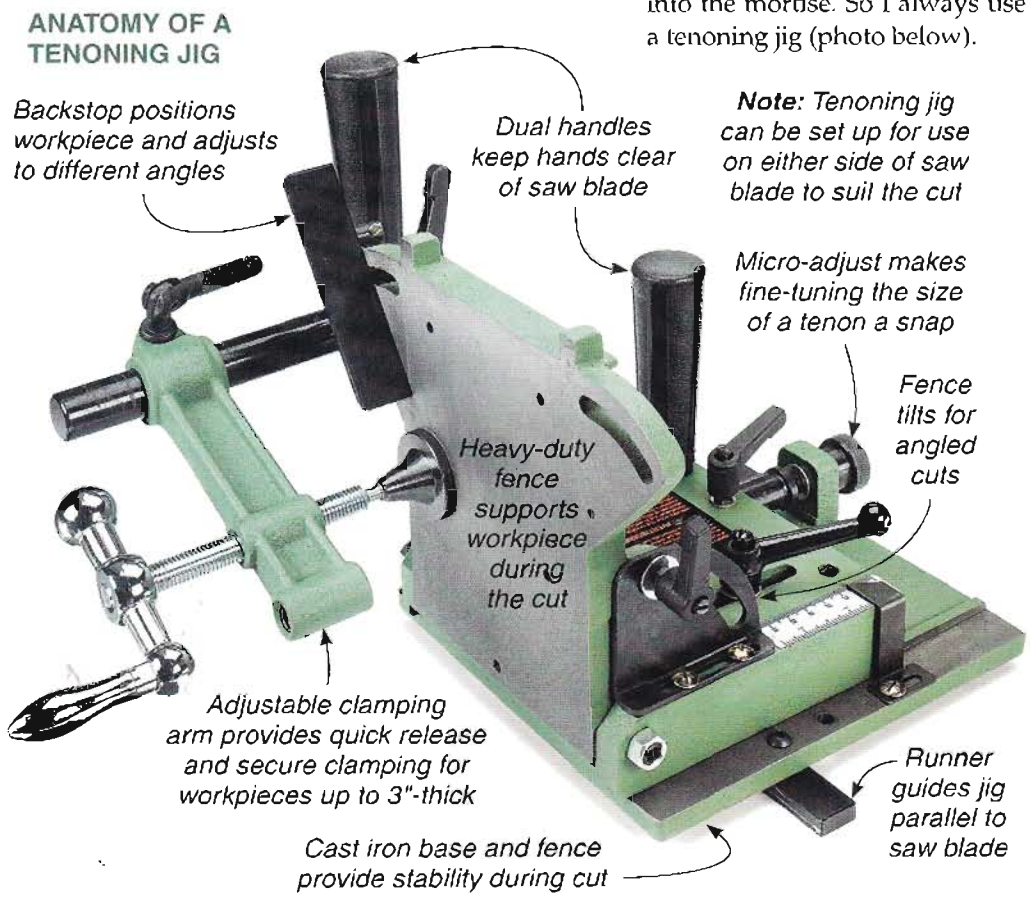

workpiece securely. And most of them feature a handy micro-adjust system, which allows you to easily fine-tune the thickness of the tenon you're working on. Some tenoning jigs may even have a scale to help you size the tenon, while others rely on adjustable stops.

TABLE SAW SETUP

A tenoning jig goes a long way toward helping you cut perfect tenons. But there are a few things on the jig you'll want to check and verify before you start with the step-by-step procedure on the following pages.

The first thing to look at is your table saw. The best tenoning jig in the world won't do you much good if your table saw isn't tuned up and ready to go.

A plastic drafting triangle is an accurate way to check that the saw blade and rip fence are square to the surface of the saw table (upper right photos). You'll also want to make sure the miter gauge slot and saw blade are parallel. Note: Refer to your owner's manual if you need to make any of these adjustments.

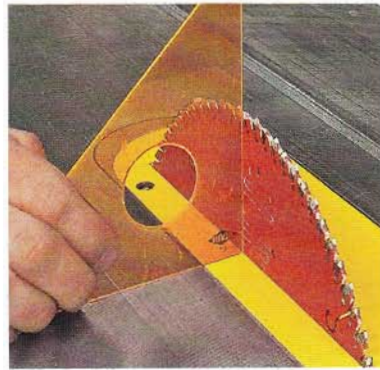

Square the Blade. Make quick work of checking the blade for square with a drafting triangle.



Check the Rip Fence. For even tenon shoulders, the rip fence should be square to the table.

FINE-TUNE THE JIG

Once your table saw is in good order, move on to the next step, fine-tuning the tenoning jig.

SQUARE UP THE FENCE. The first step here is to check the fence of the tenoning jig. To ensure that the tenon is a consistent thickness, the fence needs to be square to the surface of the saw table. You can see how to square the fence in the lower left photo.

ADJUST THE BACK STOP. While you're at it, make sure that the backstop on the fence is square to the table. Most backstops tend to be short, so I find it best to use a long workpiece while checking this.

You can see what I'm talking about in the center photo below.

CHECK FOR PARALLEL. There's one last important step to complete your setup. And that's to confirm that the face of the fence is parallel to the saw blade. If it's even slightly out of parallel, the tenon cheeks will end up angled, or "twisted," to the rest of the workpiece.

What's nice is that this is a simple adjustment to make. Start by sliding the fence face against the saw blade, like you see in the lower right photo. Once the teeth of the saw blade touch along the entire face of the fence, securely tighten the runner in place.

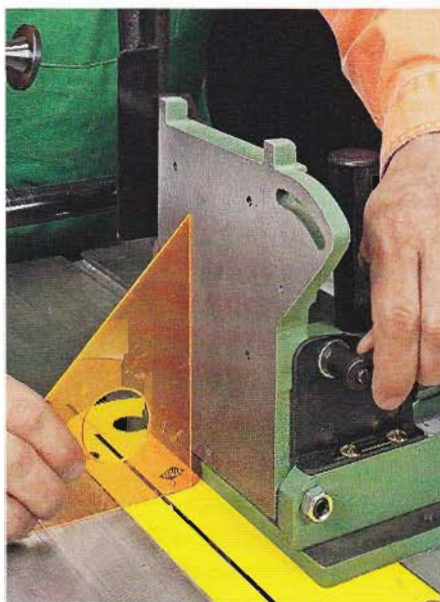

Square the Fence. Once you have the fence adjusted square to the saw table, lock it securely in place.

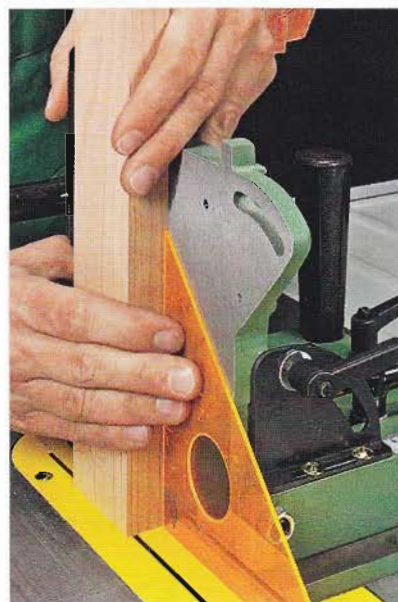

Adjust the Backstop. A long workpiece makes it easier to square the backstop to the saw table



Ensure Parallel Operation. Finally, align the fence flush with the saw blade, and secure the base to the runner.

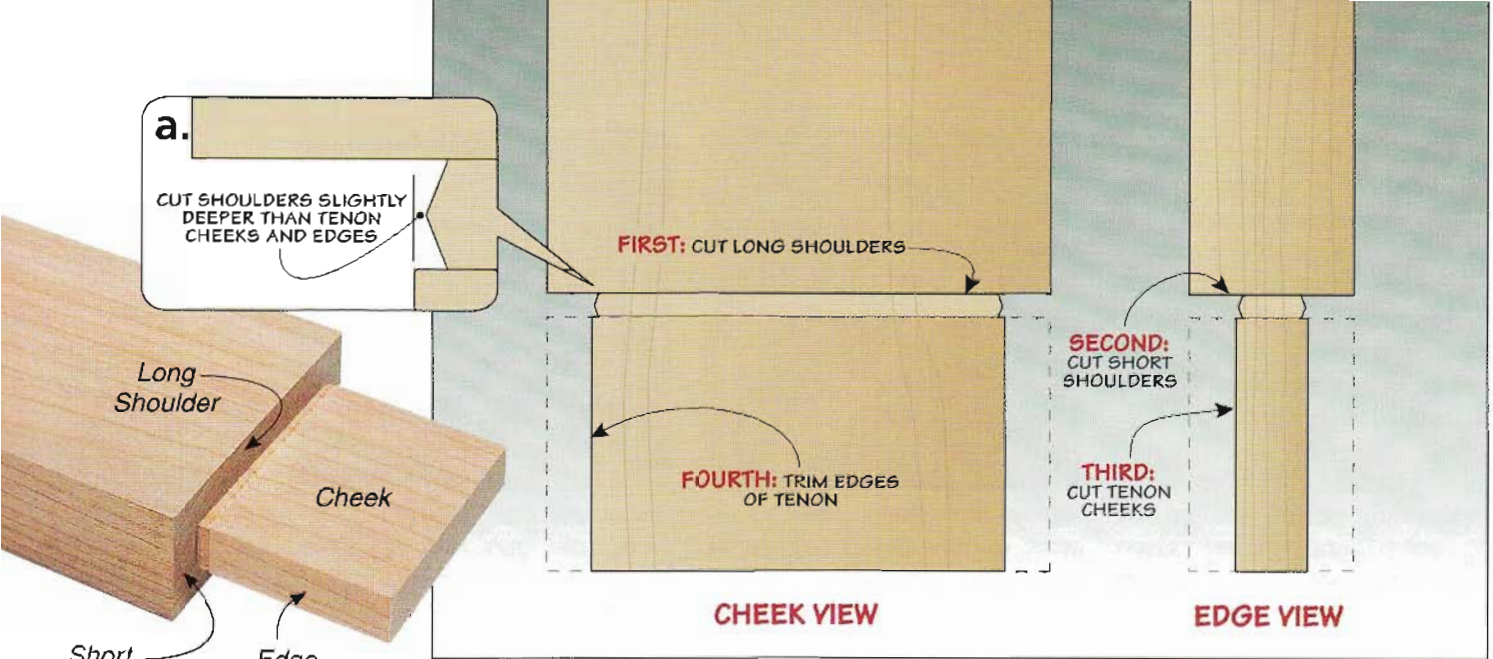

Cutting a Perfect Tenon

Once you have your table saw tuned up and your tenoning jig adjusted properly, you're ready to start cutting tenons. The process is fairly simple and results in tenons like the ones you see in the photo and drawings above. It's really just a matter of making the cuts in the correct order.

STEP-BY-STEP PROCESS. The first step is to cut clean, crisp shoulders. This ensures a tight, seamless fit against the mortised workpiece. After that, you'll cut the cheeks so the thickness of the tenon matches the width of the mortise. And finally, completing the tenon is just a matter of trimming the

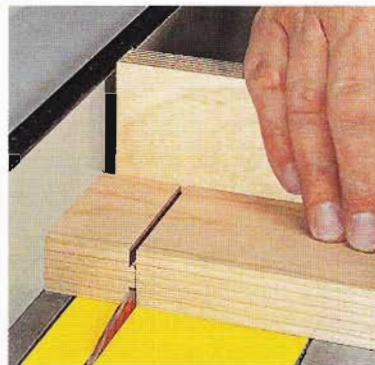

Long Shoulders First. Using the fence as a stop, cut the long shoulders to set the tenon length.

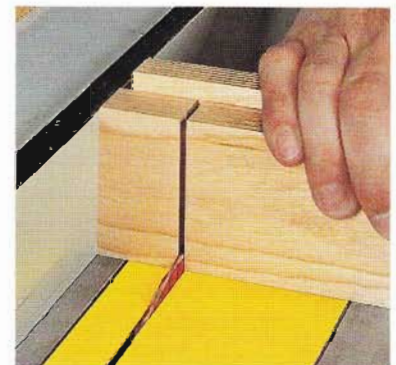

Short Shoulders Next. Complete the short shoulders by standing the workpiece on edge.

edges so the tenon slides into the mortise with a smooth, snug fit.

It's always a good idea to have test pieces handy to use during each part of the process. And marking layout lines on the test pieces makes it easier to fine-tune the setup. Then, once you have the settings correct, you can

cut all of the workpieces at that setting. As you work, check out the box on the opposite page for some handy troubleshooting tips and the best solutions. ←

SHOULDERS FIRST

As I mentioned, the place to start is with the shoulders. The important thing to keep in mind here is that this is what really makes or breaks the final look and fit of the joint. You'll want to ensure the cleanest shoulders possible, so make the cuts with a crosscut blade (I use one with 80 teeth) and a zero-clearance insert.

A combination blade would also work for all of the cuts you'll need to make. I've found that installing a crosscut blade for the shoulder cuts, however, is a small price to pay for crisp, clean results like you see here.



Test Fit. You'll know you have the jig set correctly when the tenon just slips into the mortise.

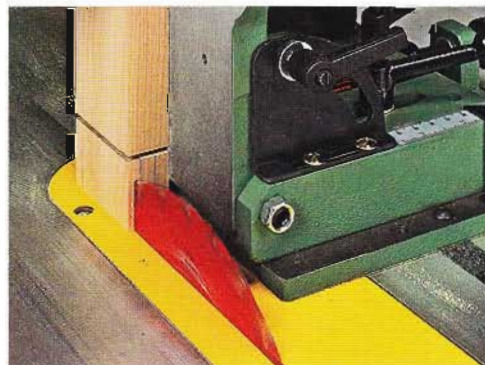

Cheek Cuts. After making the first cheek cut (above), flip the workpiece for the second cut and then test the fit (left).

Besides using a crosscut blade, I make sure to attach an auxiliary fence to my miter gauge, as shown in the center of the opposite page. The auxiliary fence backs up the cut, minimizing any chance of chipout.

Once you have the auxiliary fence attached to your miter gauge, you're ready to begin cutting. Start by positioning the rip fence to establish the desired length of the tenon.

Next, you need to set the depth of cut (drawings on opposite page). I like to use a slight undercut to create a relief space. I find this makes it easier to remove the cheeks and edge waste later. You don't risk cutting into the clean shoulders. Note: Depending on the size of the tenon, you may need to readjust the blade height for the short shoulder cuts.

CUTTING THE CHEEKS

With the shoulders complete, you can move on to the cheek and edge cuts. Since these are rip cuts, I like to remove my crosscut blade and install a rip blade. As I said earlier, you could also use



Remove the Edges. With the tenoning jig reset for the edge cuts, repeat the process for removing the waste, testing the fit as you go (photo at right).



A Snug Fit. After sneaking up on the final fit, it just takes firm hand pressure to seat a perfectly sized tenon.

a combination blade. But if you have a lot of tenons to cut, a rip blade will give you quicker cuts and cleaner cheeks and edges.

Next, set the tenoning jig in place and adjust it so the waste will fall to the outside (right photo at the bottom of the opposite page). I like to make my first cuts just to the outside of my layout lines. Then, after testing the fit, simply adjust the fence (and workpiece) a bit closer to the blade and make both of the cheek cuts again. This allows you to sneak up on the final fit (lower left photo on the opposite page).

TRIMMING THE EDGES

When the corner of the tenon fits into the mortise, finish by cutting the edges free. This process is the same as the cheeks. To ensure that waste drops to the outside of the blade, reposition the jig to the opposite side for the edge cuts.

Start the cuts just a little outside your layout lines (upper left photo). After sneaking up on the fit, a little pressure should seat the tenon (upper right photo).

The feel of a well-fit tenon sliding into place can't be beat. This step-by-step process and a tenoning jig make it quick and easy.

Troubleshooting Tips

As you're making your test cuts, it can be a challenge to determine the solutions to any problems that come up. Using the drawings at right, you can zero in on the solution. Some require you to adjust either the jig or table saw while others provide solutions to problems with your actual workpieces.

If the tenon ends up tapered or dovetail-shaped (upper right drawings), check that both the saw blade and face of the tenoning jig are exactly 90° to the saw table. If you end up with shoulder cuts that don't go deep enough (near right) or have a stepped short shoulder (far right), the solution is to clean up the waste with a sharp chisel.

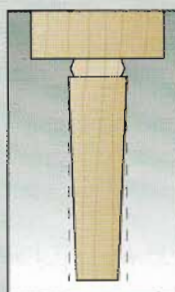

Tapered. If your tenon tapers toward the end, the saw blade is tilting away from the jig or the jig face is tilting away from the blade.

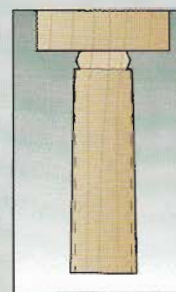

Dovetailed. A dovetail-shaped tenon means the saw blade is tilting toward the jig or the fence of the jig is tilting into the saw blade.

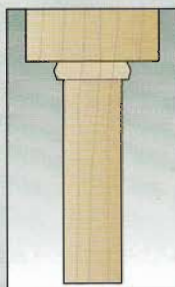

Waste. If you have a "ridge" running around the shoulder of the tenon, you'll need to use a chisel to remove the waste.

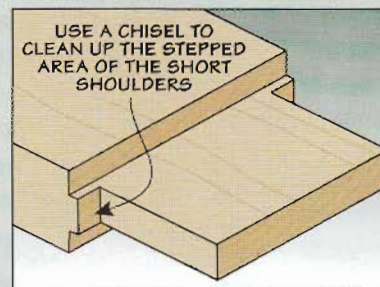

A Step. A stepped short shoulder is a possible indication that your rip fence is tilting slightly toward the saw blade.

Stub Tenon & Groove Joinery

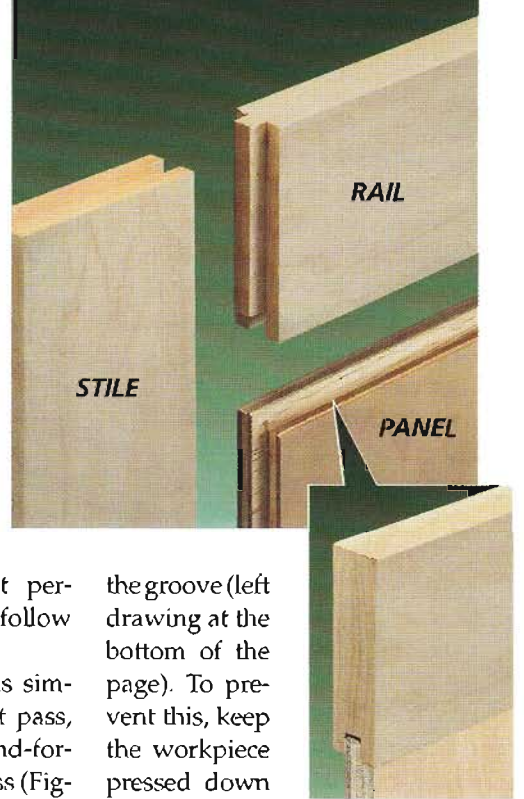

Whenever I'm building a frame and panel assembly that uses a plywood or hardboard panel, I like to use a stub tenon and groove joint. It's quick and easy to make, plus the assembly is incredibly strong since you can glue the panel into the frame.

GROOVES

The first step in creating a stub tenon and groove joint is to cut the grooves in the rails and stiles that make up the frame.

FLIP WORKPIECE. In most cases, the groove is centered on the edge of the frame piece. But don't worry about centering it perfectly on the first try. Just follow the process in Figure 1.

The reason this works is simple. After making the first pass, you flip the workpiece end-for-end and make a second pass (Figure 1b). Even if your blade isn't centered, the groove will be.

To fine-tune the width of the groove, nudge the rip fence over a little and repeat the process. Since you're removing material from both sides of the workpiece, it's best to make small adjustments and sneak up on the final width.

TROUBLESHOOTING. Flipping the workpiece to center the groove is only part of the process. The workpiece also needs to stay tight against the rip fence. So I like to use a featherboard (Figure 1).

Another problem is not cutting deep enough. This can happen when the workpiece "rides up" during the cut, causing a step in

the groove (left drawing at the bottom of the page). To prevent this, keep the workpiece pressed down against the saw table. Be sure to check the groove after each cut and, if necessary, make another pass.

GROOVE WIDTH. There is one thing to mention about the width of the groove. If I'm using $\frac{1}{4}$ " plywood or hardboard, I cut the groove to match its thickness — which is often slightly less than $\frac{1}{4}$ " thick.

But if I'm working with $\frac{1}{2}$ " plywood, I cut a $\frac{1}{4}$ "-wide groove and then cut tongues on the panels to match (inset photo above).

BLADES. And if the bottom of the grooves will be visible (like on a frame and panel door), it's best to use a rip blade to make a flat-bottomed cut (drawing below).

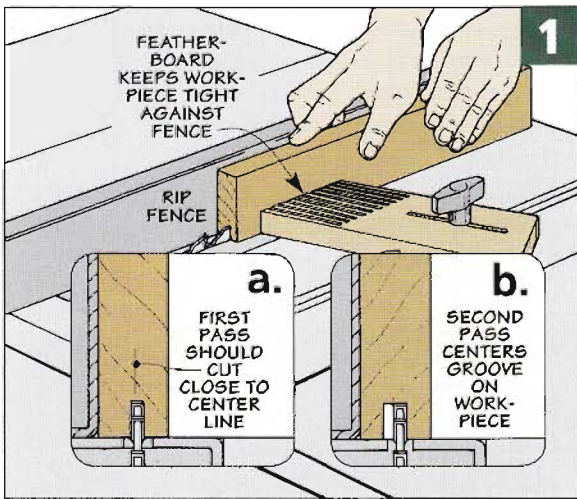

Troubleshooting Grooves

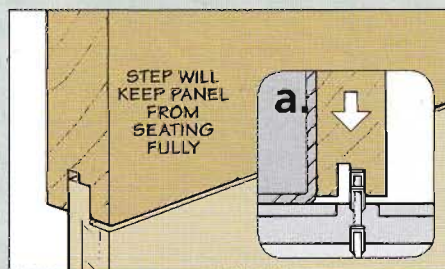

Downward Pressure. To prevent steps in the bottom of the groove, hold the workpiece firmly against the saw table.

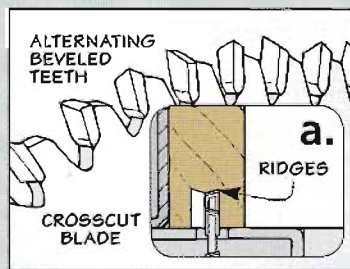

Blade Choices. A crosscut blade produces grooves with ridges. A better choice for cutting grooves is a rip blade. The flat-topped teeth produce a groove with a perfectly flat bottom.

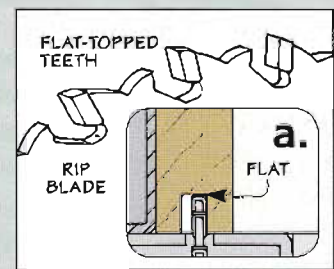

STUB TENONS

Once the grooves are complete, the next step is to cut the stub tenons on the ends of the rails. A single setup with a dado blade is a quick way to do this in two passes.

After burying the dado blade in an auxiliary fence (Figure 2), simply adjust the fence to set the length of the tenon (Figure 2a).

BLADE HEIGHT. The next step is to establish a centered tenon that's the correct thickness. As before, the idea is to make two passes, flipping the workpiece over between each pass (Figure 2b).

But you still need a starting point. Using the groove as a guide, raise the blade until it's just about even with the shoulder of the groove (Figure 2a). Here again, make your cuts on a test piece and check the fit.

After cutting all the stub tenons on both ends of all the rails,

you can turn your attention to the tongues on the ½" plywood panels. For this you can leave the rip fence set and simply adjust the height of the blade to cut a rabbet along the edge of the panel. Once again, you'll find it's best to sneak up on the fit.

ASSEMBLY

At this point, you're just about ready for assembly. But it's always a good idea to dry assemble things to check for problems.

SAND. Then you can sand the face of the panel as well as the inside edges of the stiles and rails, which are difficult to sand later.

GLUE. Gluing up the assembly is just a matter of following the process shown in Figure 3. To keep glue squeezeout to a minimum, I only apply the glue on the inside face of the tongue on the panel. But I do apply glue to both sides

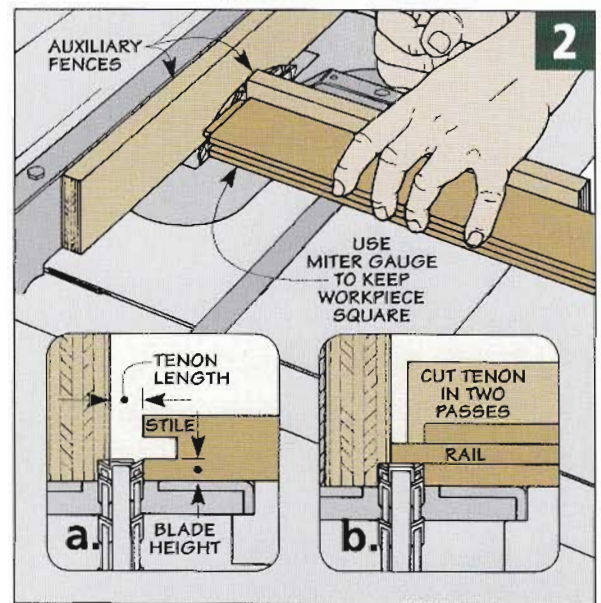

of the tenons on the rails, like you see in Figure 3b.

After clamping the pieces together (Figure 4), check to see that the frame is flat and square. If it isn't flat, try loosening the clamps a bit. And if it isn't square, try repositioning them slightly.

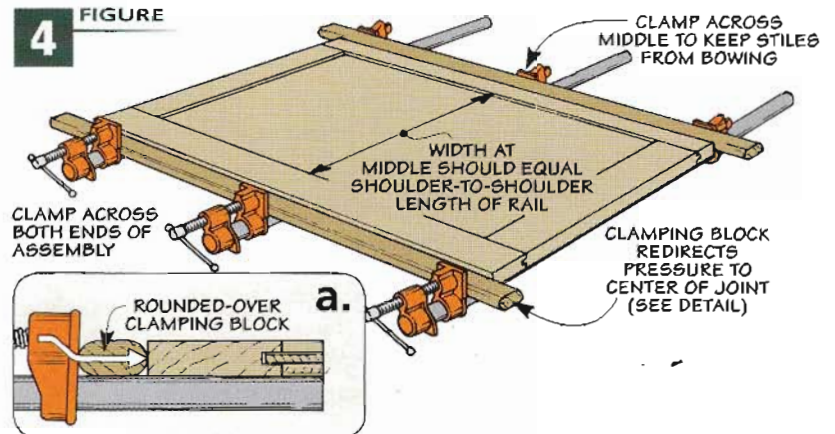
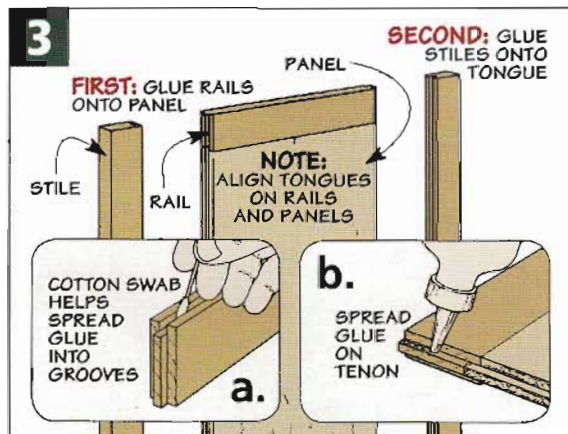

Troubleshooting Stub Tenons

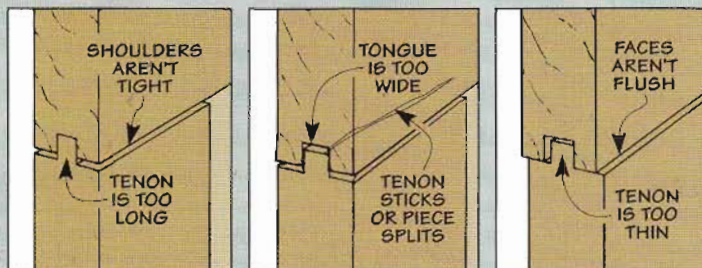

Tenon Troubles. When the tenon is too long (left) or too wide (center), assembly is difficult. A tenon that's too thin (right) results in a poor glue joint and makes it hard to align the faces.

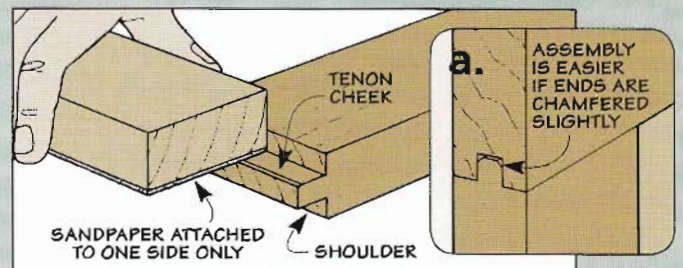

Fitting the Tenon. Lightly sand the tenon cheeks and chamfer the ends to get a good fit in the groove. But stay clear of the shoulder to keep it sharp.





Advanced Techniques

Some cuts seem impossible to make on the table saw, but we'll show you how to do them safely and accurately. You'll be able to take your projects to a new level of detail.

MAKING A BEVEL RIP CUT.....42

CUTTING PERFECT CIRCLES.....44

TRADITIONAL RAISED PANELS.....46

PATTERN CUTTING48

Making a Bevel Rip Cut

With proper setup and the right technique, you'll end up with a perfect bevel cut.



Ripping a workpiece on the table saw is a pretty straightforward task for most woodworkers. But when you tilt the blade for a beveled cut, the process suddenly causes most of us to pause.

Still, there's no reason for concern. Starting with a solid setup and using the correct technique, you'll find that ripping a clean, smooth bevel is a snap.

SETTING UP THE SAW

Before getting into the specific techniques for making consistent bevel cuts, there are a few

things to mention. First, you'll get less cutting resistance and safer, cleaner cuts by starting with a sharp blade. I like to use a good quality rip blade. But a combination blade will do in a pinch.

Next, you'll want to check the alignment of the rip fence. You can avoid the chance of binding or a burned and scarred cut by

ensuring the rip fence is perfectly parallel to the saw blade.

Finally, when you're making any type of rip cut, a good push block and a properly installed featherboard are essential (left drawing). Both help maintain solid control and minimize any chance of kickback.

START WITH A PUSH BLOCK. The push block I use is easy to make. It's just a 2x4 scrap (main photo) that's notched along the bottom edge. This forms a "heel" at the back end and allows you to provide a firm, steady push along with the downward force necessary to keep the workpiece securely against the table.

ADD A FEATHERBOARD. For better control, you can add an extra set of "fingers" with a lock-in featherboard. A featherboard takes over the responsibility of keeping the workpiece snug against the rip fence. With the firm, continuous pressure of the featherboard, the workpiece can't

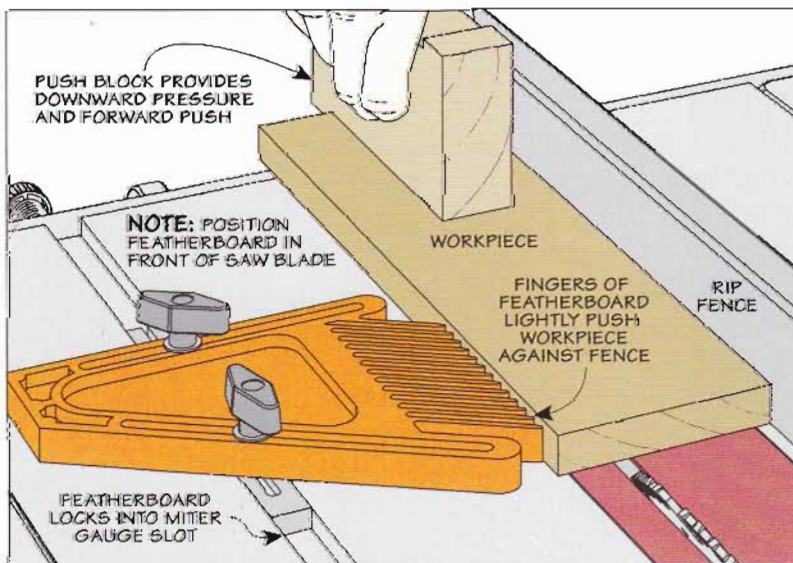

wander away from the fence. And since the fingers only allow movement in one direction, the chance of the workpiece being kicked back is nearly eliminated.

In order for a featherboard to do its job well, it has to apply the pressure in the right spot and with the correct amount of "push." Check out the drawing on the opposite page for more on adjusting it properly when you're setting up to make the cut.

MAKING THE CUT

At this point, you're just about ready to make a cut. And the last part of the setup process is just a matter of safely positioning the rip fence and the workpiece.

The correct way to make a bevel cut is shown in the main photo. Here you see that the blade is tilted away from the fence in order to prevent the workpiece from being trapped and kicked back (upper right drawings).

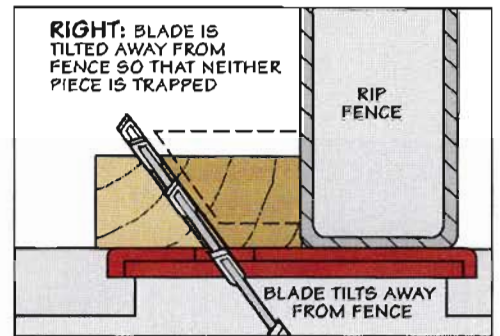
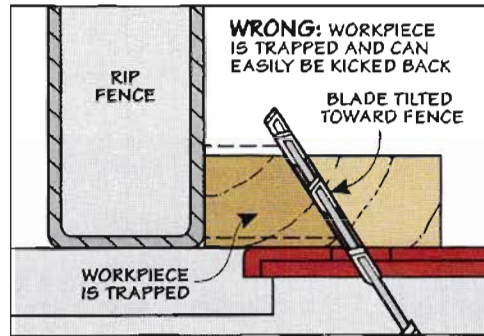

The left drawing above shows that when the blade tilts toward the fence, the workpiece is trapped. If the workpiece shifts, it can be pinched between the blade and fence and then kicked back. When you make a bevel cut as shown in the right drawing, neither piece is trapped.

On a left-tilt saw, this isn't much of an issue. Just tilt the blade to the desired angle. But if you have a right-tilt saw (like mine), you'll have to shift the rip fence to the left side of the blade, which isn't a big deal.

POINT UP. If you have to bevel both edges of a workpiece, there's one thing to keep in mind. For the second cut, you want the beveled point of the workpiece (the one against the fence) to be up off the table, as in the far left drawing below. Otherwise, the point can wedge under the rip fence.

EXCEPTIONS. Of course, you can't always have the point up when making the cut you want. It's still safest to tilt the blade away from the fence, but I attach the piece to a 1/4" hardboard sled (right drawing). The sled "lifts" the point off the table so it can ride securely against the rip fence.

The other exception is beveling a wide workpiece. If your saw doesn't have the capacity to do this, use the technique below.

Use these setups and techniques to cut safely, and you'll end up with a perfect bevel cut.

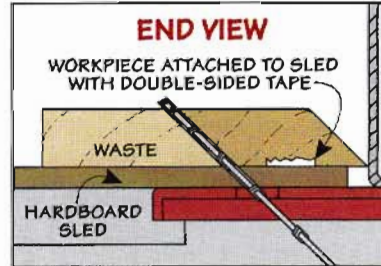
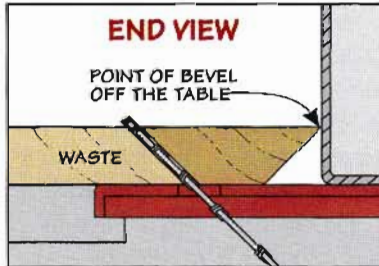

Breaking the Rules: A Wide Workpiece

It's always a goal to make any bevel cut with the saw blade tilted away from the rip fence. Unfortunately, that won't work if you're cutting a wide workpiece and you have a right-tilt saw. With most saws, there's simply not enough rip capacity to move the fence to the left of the blade.

When that's the case, you can make your cuts with the blade tilted towards the fence. Note: Be sure to use a hardboard sled if necessary to keep the opposite bevel from slipping under the fence.

What makes this a safer operation is that you can firmly push the workpiece through the blade using both hands (right drawing). If the piece is bowed, it's important to keep it flat against the table (drawing below). By applying continuous downward pressure, the bevel will be consistent and you minimize the risk of kickback.

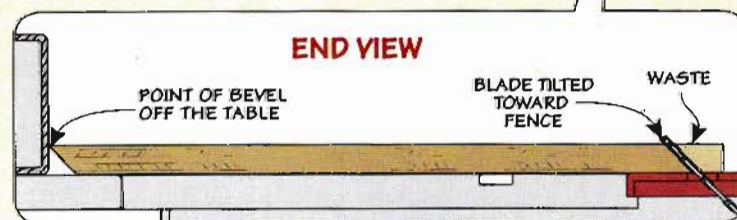
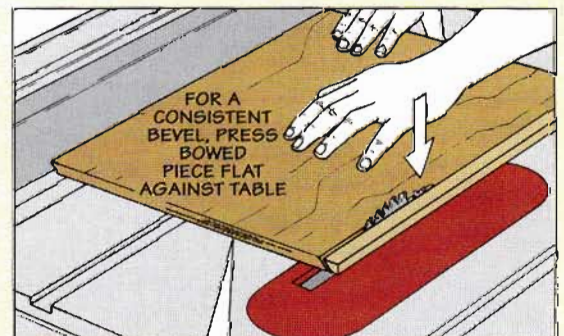



Cutting Perfect Circles

Cut a circle with crisp, clean edges on the table saw? Absolutely. All it takes is a simple, shop-built jig.



For a 3D model and video animation of the circle-cutting jig, check out:

WoodsmithSpecials.com

A table saw isn't the first tool you think of when it comes to cutting circles. But with a shop-built jig, cutting a circle up to 40" in diameter is quick, easy, and accurate. And it results in a surprisingly smooth, even edge.

CIRCLE-CUTTING JIG. As you can see below, the circle-cutting jig starts out as a large base with a hardwood runner glued to the bottom. The runner fits in the miter slot of the table saw and guides the jig during the cut while the base supports the workpiece.

The runner is located to position the edge of the jig flush with the teeth of the saw blade. And the base is sized so it overhangs the left edge of the table saw wing by 2". (Mine ended up 22½" x 26".)

A pair of intersecting grooves in the base accept T-track. One groove is located 8" from the front of the base. A piece of T-track installed upside-down in this groove acts as an adjustable pivot bar. To lock the bar in place, there's a knob and a flange bolt that come up through the base where it overhangs the saw wing. To create a pivot pin, I cut the threads off a #8 woodscrew

and used epoxy to glue the ¾"-long smooth shank into a counter-sunk hole drilled in the T-track.

The second groove holds two sections of T-track (one on either side of the pivot bar groove). A flange bolt, hold-down, and knob fit into the T-track to secure the workpiece during a cut.

Finally, installing a section of self-adhesive measuring tape makes it easy to set up the jig for a specific size circle. The tape is "zeroed" out at the edge of the jig that aligns with the saw blade.

USING THE JIG

Once you have the jig made to fit your table saw, using it to cut a circle couldn't be simpler. The process begins by cutting a square blank slightly larger (about ⅛") than the final diameter of the circle you want.

With the blank cut to size, the next step is to drill a centered hole in the bottom face. Size the hole to fit over the pivot pin of the jig.

SIZE THE CIRCLE. At this point, you're ready to position the workpiece on the jig. The first

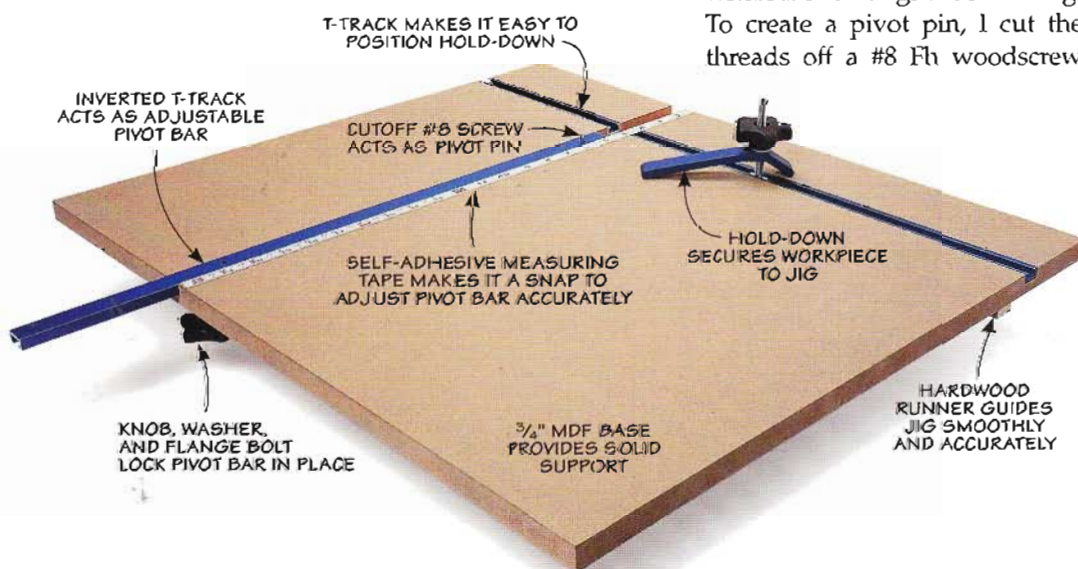

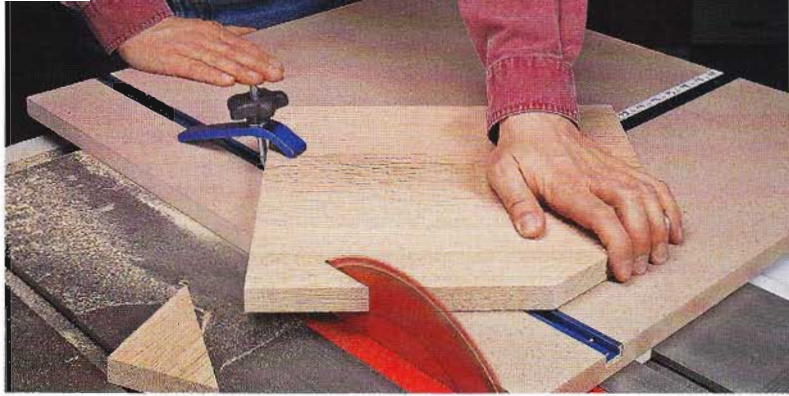

Knock Off the Corners. After setting the blank over the pivot pin, clamp it in place with one corner hanging over the edge. Once you trim the corner off, simply repeat the process for the other three corners.

thing to do here is adjust the pivot bar (and pin) to match the radius of the circle. To do this, position the pivot bar so the distance from the center of the pivot pin to the edge of the jig matches the desired radius.

Next, rotate the workpiece so a corner overhangs the edge of the jig. Once you secure the workpiece with the hold-down, simply trim off the waste. Then, repeat the process for the other corners, like you see in the left photo at the top of the page.

Completing these cuts results in a workpiece with a “rough” octagonal shape. The next step is to repeat the trimming process by knocking off the smaller waste “corners.” This is shown in the upper right photo.

As you can see, the workpiece is beginning to look like a circle.

If you’re cutting a large circle, you may need to repeat the trimming process a couple of times, clamping the workpiece in place for each of the cuts.

FINAL SHAPING. The last step is to rotate the workpiece a number of times — trimming away small amounts of waste with each rotation. To do this, simply “nudge” the base forward slightly, and then rotate the workpiece a complete 360°. This will trim off a small amount of waste near the back edge of the workpiece. As you do this, be sure to keep your hands well away from the saw blade. (I keep my hands to the left of the clamping T-track at all times.)

To end up with an edge that’s square to the face, you’ll need to repeat this process: Move the jig forward a bit more, and rotate the workpiece again. Do this as



Continue Trimming. At this point, you have an octagonal shape. The next step to creating a circle is to trim off the newly created “corners.”

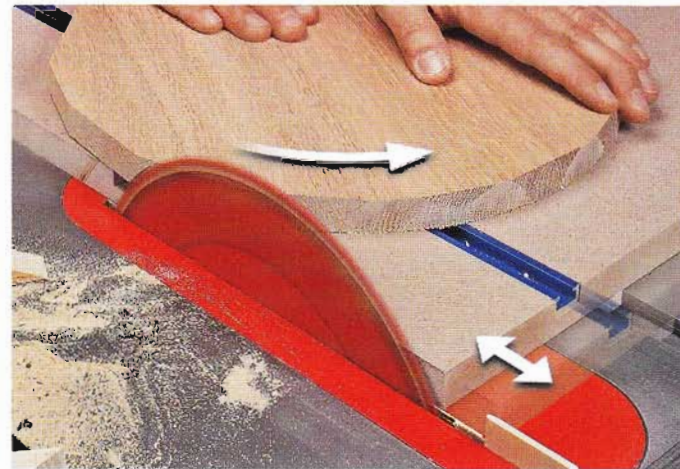

many times as necessary until the entire edge is smooth and square, like you see in the main photo.

Don’t worry, the entire process of creating a circle takes just a few minutes. And the end result is a perfectly sized circle. For the smoothest edge possible, check out the box below.

Shape the Edge.

Finally, rotate the workpiece as you trim away the final waste. You’ll need to move the jig forward slightly after each rotation.

Smoother Edges with a Sanding Disk

While a good table saw blade provides a clean edge, you may want to sand it even smoother. The solution is to install a sanding disk in your table saw, like the one below.

(It also doubles as a setup plate for tuning up your table saw.)

Just attach a self-adhesive sanding disk to the plate, and the circle-cutting jig will work for sanding. After turning on the saw, simply adjust the pivot bar (and workpiece) until it just starts sanding, and then lock the bar in place. With just a few turns of the workpiece, you’ll end up with a smooth edge. Sources for sanding disks are provided on page 98.



Sanding It Smooth.

Installing a sanding disk in your table saw allows you to use the circle-cutting jig to sand a perfectly smooth edge.

Traditional Raised Panels

Make your cabinets stand out with raised panels cut on the table saw

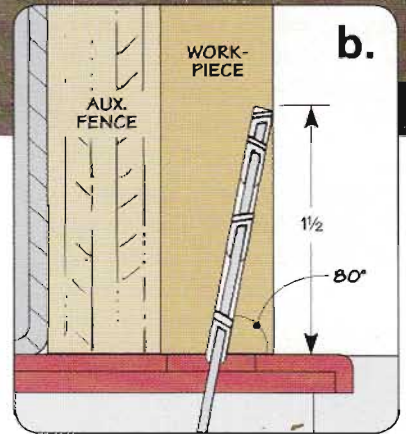

One of the simplest cabinet doors to make is a frame and flat panel door. You build the frame and slide a 1/4" plywood panel into it. But what if you want to dress that door up a little bit more?

One way to add interest to the door is to substitute a raised panel for the flat one.

And you can add this traditional detail by cutting the panel on your table saw using a simple two-step process.

The first step is to bevel the edges of the panel to raise a "field" in the center (left drawing). The second step is cutting a rabbet along the back edge of the panel so it slides right into the door frame (detail 'a').

CREATING THE FIELD

Before you begin working on the raised field, you need to cut the panel to final size. To do that, you'll first need to dry-assemble the door frame and measure the distance between the grooves. Then, you can cut the panel 1/16" narrower, which will allow it to move with humidity changes.

With the panel cut, you're ready to make the raised field. The first thing you'll need to do is set your rip fence and saw blade.

SETUP. What's important here is to tilt the blade away from the fence to prevent trapping the waste between the blade and the fence. Because the panel will be standing on edge as you make the cut, you'll want to use a zero-clearance insert and a tall auxiliary fence to provide solid support (box on opposite page).

I've found that tilting the blade 10° and raising it 1/2" will give you a nice-looking panel. Then, to add an extra detail to the panel, I like to set the fence so the blade will leave a 1/8" shoulder between the field and the bevel (detail 'b').

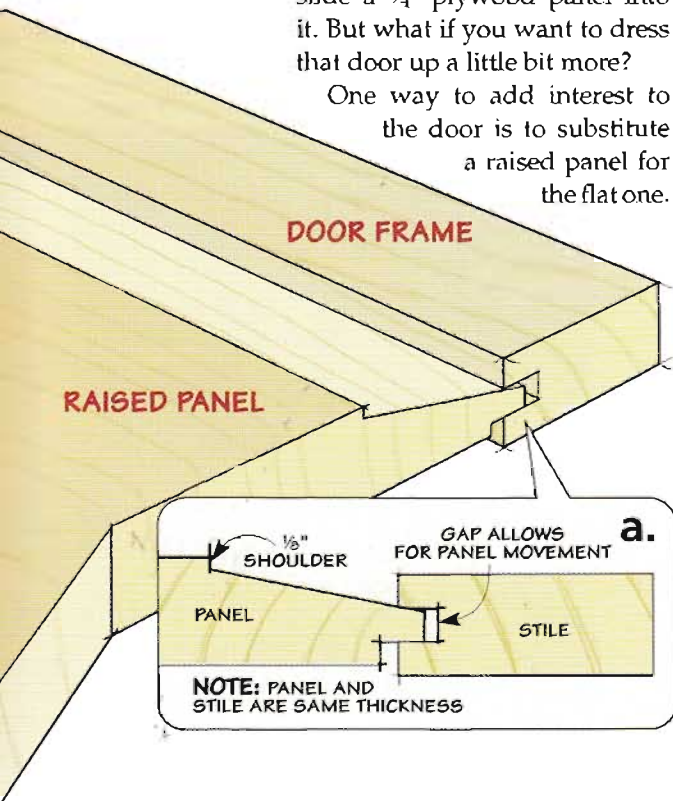

MAKING THE CUT. Now you can make a bevel cut on each edge of the panel. Since the end grain is more likely to tear out at the end of the cut, be sure to cut these edges first. Cutting the other two edges will remove tearout.

To keep the panel firmly against the fence, I also like to use a tall featherboard. The box below shows how to build it.

CLEANING UP. After you make the cuts, it's normal to find saw marks on the bevels. Plus, the shoulder won't be square to the face of the panel. A simple way to fix both problems is to use the beveled sanding block shown in Figure 1. It squares up the shoulder of the field as you sand away the saw marks (Figure 1a).

CUTTING THE RABBET

Now that the field is done, you're halfway through creating a raised panel. At this point, the edge of the panel is too thick to fit into the

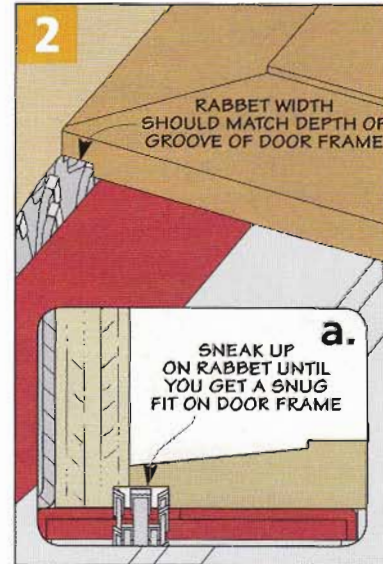
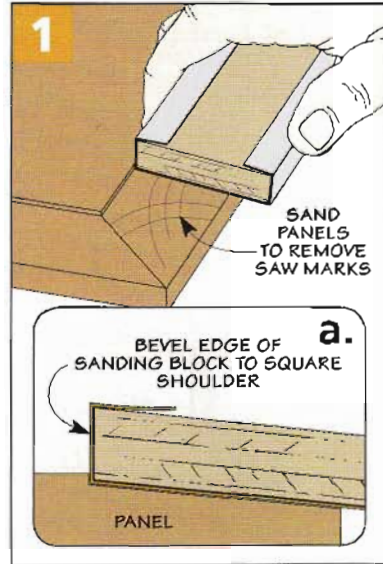

groove of the door frame. That's where the second step of the process comes in — cutting a rabbet along the back edges of the panel to get a nice fit (Figure 2).

The rabbet is sized so the panel can slide into the frame, but not so loose that it rattles around. The best way to fit the panel is to

“sneak up” on the depth of the rabbet until the panel just slips into place. Also, the rabbet should be as wide as the groove is deep to allow the panel to expand and contract (Figure 2a).

And that's it — two simple steps and your new raised panel is ready for the door frame.

Shop-Made Accessories

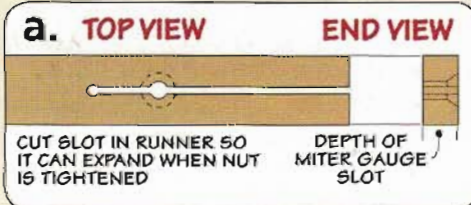
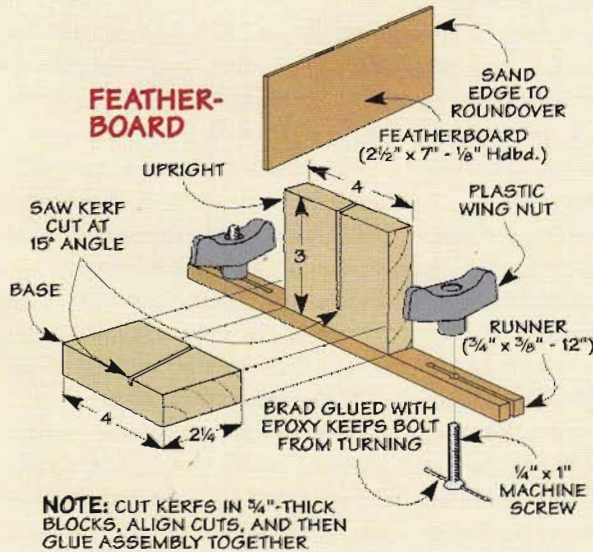

Cutting a raised panel on a table saw requires you to stand the panel on edge when making the cuts. The two accessories shown here will provide you with solid support and help make the task go much smoother.

Featherboard. The featherboard shown at left helps by keeping your fingers out of the way while pressing the panel firmly against the fence, and it's quite simple to build. All you need is a strip of 1/8" hardboard that's held in place by an L-shaped block attached to a hardwood runner.

Auxiliary Fence. The auxiliary fence you see on the right should fit snugly over your table saw fence. It should be tight enough that the fence won't slide as you push the panel. You can also add a cap to one end of the auxiliary fence to keep it from slipping. The taller side of the fence should be high enough to keep the panel stable while it passes through the blade.

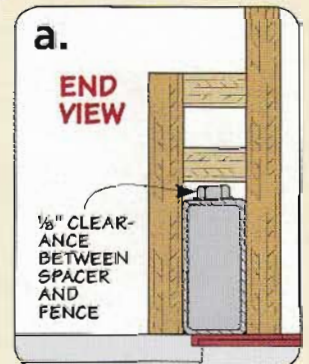
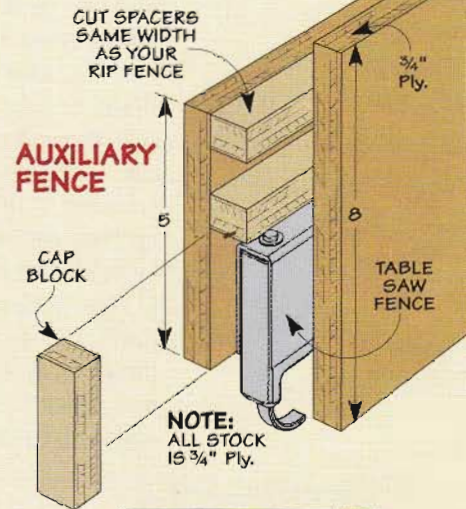

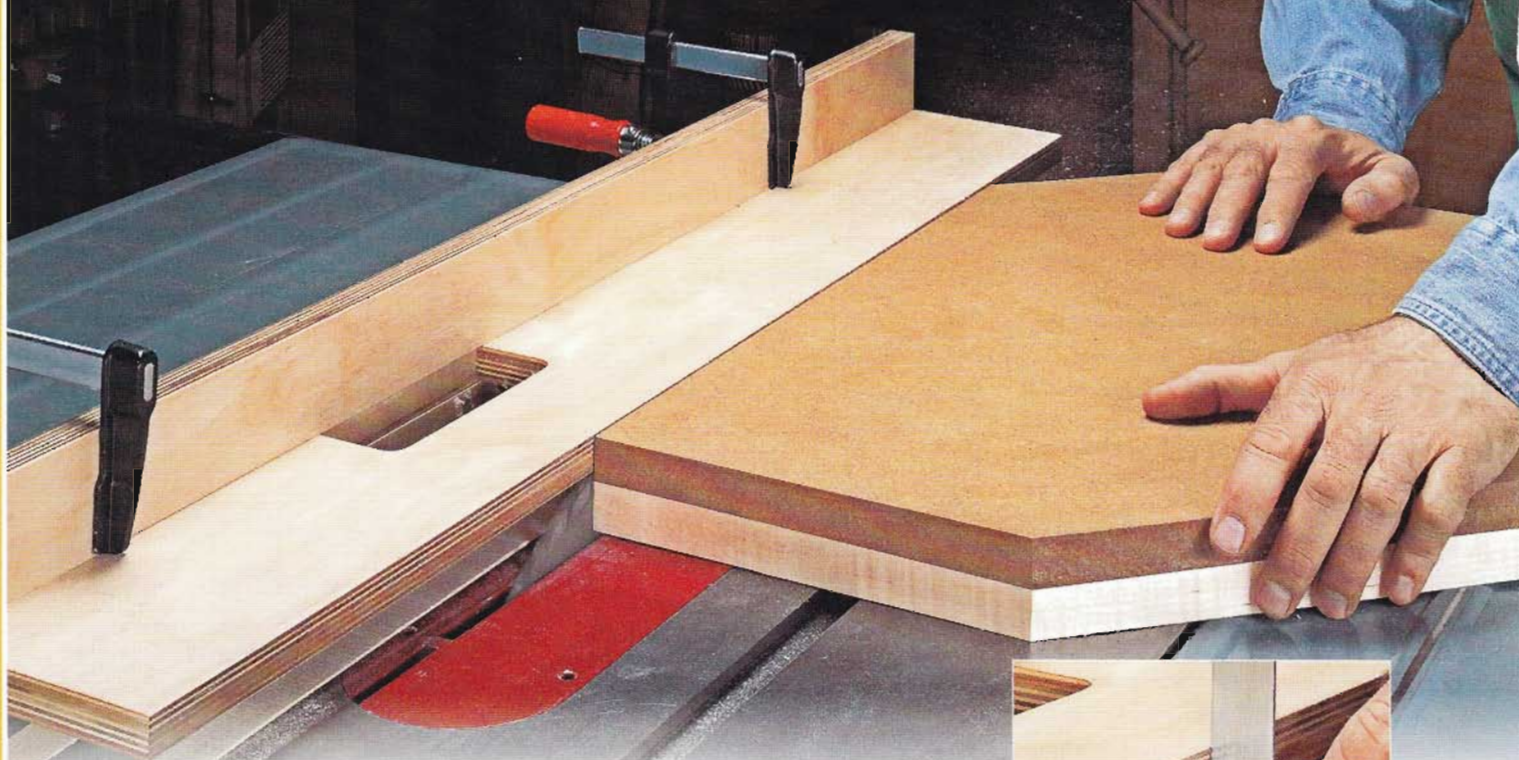

Pattern Cutting

This technique takes the challenge out of cutting multiple odd-shaped pieces to size.



Have you ever faced the task of making multiple copies of an odd-shaped workpiece and not had any idea how to get the job done? So you stand staring at a pile of wood and hope that a sudden inspiration will provide the solution. Well it could be that the answer you're looking for is the table saw trick of pattern cutting.

This technique allows you to duplicate straight-edged workpieces on the table saw accurately and quickly. The large dividers and shelves of a corner cupboard,

as shown in the photo above, are a good example. But any hard-to-cut workpiece with straight sides is fair game for pattern cutting.

THE SECRET. Pattern cutting on the table saw may seem a bit odd. But just think of it as similar to template routing. If you take a look at the lower left drawing, you can see how it works.

You start by clamping a simple pattern-cutting fence to the rip fence of your table saw. The horizontal arm of the fence is aligned directly above the blade of the saw to act as a "rub" guide. And a pattern attached to the workpiece follows the edge of the guide arm to "steer" the workpiece past the blade. Follow this plan and the result is a flush cut that creates a perfect copy of the pattern. The advantage to this technique is that all you need is a master pattern and one simple setup.

THE FENCE. The first item on the pattern-cutting "checklist" is the guide fence. If you take a close

look at the photo above and the drawing at left, you'll be able to put one together pretty easily. So I'll just give you a few pointers.

You'll want to make the guide fence the same length as your rip fence. I like the long, steady guide surface this provides. And when I'm pattern cutting, it's usually on $\frac{3}{4}$ "-thick stock. So the guide arm is attached to the upright about $\frac{7}{8}$ " from the bottom edge.

The cutoffs from the workpieces will fall harmlessly between the upright and the saw blade. Usually these will only be narrow strips. But even so, you need plenty of room for them. A 4"-wide guide arm creates the space you'll need. Finally, notice the window just opposite the blade.

This lets me see when I need to do a little housekeeping and clean out the cutoffs.

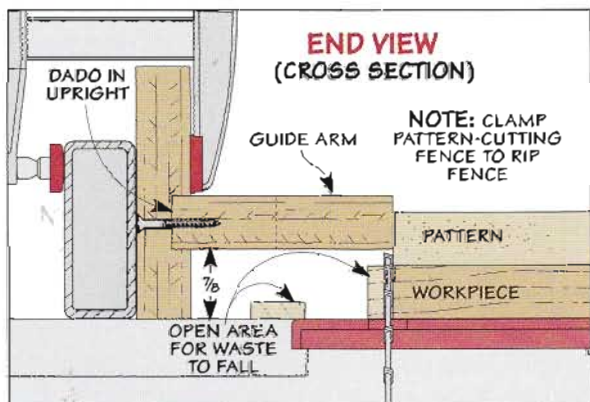

THE PATTERN. Next comes the pattern. This should be made to the exact size and shape of the parts you want to duplicate. Plywood or MDF works great. Keep in mind that once you make the pattern, the hard work is over, so take the time you need to get it right. Extra time here will be more than made up for later on.

SETTING UP

With the fence and the pattern in hand, you're ready to get set up. When you install the fence on the saw, the edge of the guide arm needs to be directly above the outside edge of the blade. A square helps get it close (inset photo at left). But I like to start out with the blade set a little behind the edge of the guide arm and then readjust it after a test cut. Hitting it dead-on may take a little trial and error.

With the fence in place, I don't start cutting on the table saw right away. First, I make a quick trip to the band saw to rough cut the workpieces. If you only have to trim off a little bit of waste, the cuts go easier and you won't

have to clean out the cutoffs quite as often.

Don't worry about the workpiece staying in place. There are several ways to fasten it to the pattern. If you don't want to leave any marks, a few strips of double-sided tape will do the job, as shown in the drawing above. When the workpieces are especially large or have a face that won't show, I'll tack or screw the pattern in place. Regardless of the method you use, make sure the attachment is good and solid.

MAKING THE CUT

Making the cut is pretty routine. Butt the pattern firmly against the guide arm well in front of the blade and then slide it forward. If the feed is stiff, some wax on the pattern and guide arm will help.

Feeding the pattern and workpiece along the guide arm may be a little awkward at first. If the pattern wanders away from the fence and the cut isn't smooth and

straight, don't worry — all you need to do is make a second pass. Remember, with the fence in place, you can't cut too deeply.

As you cut around the pattern, use a steady feed rate like you would for any cut. Even when the cutting is easy, don't go too fast. Keep an eye on the scraps building up under the guide arm and clean them out when needed.

You might find that it takes you longer to get everything set up than it actually does to cut the workpieces. But all in all, you'll get the job done quicker, easier, and much more accurately. And that's a good enough reason for me to use pattern cutting.

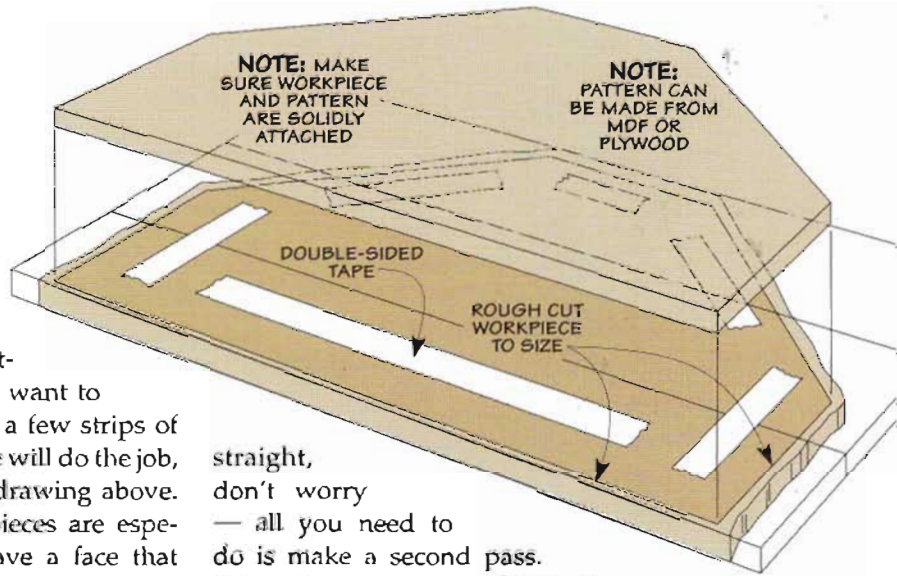

To view a video of this technique, go to our website:

WoodsmithSpecials.com

Square an Edge

Sometimes, all you need to do is cut one straight, square edge across the end of a panel. But manhandling a large panel through the saw guided only by the miter gauge can be a challenge at best. As you see in the photo at right, the pattern-cutting fence and a straight cleat will help you get the job done right.

Just set up the fence as you would for a pattern cut. Then tape or tack the cleat to the workpiece with the straight edge right on the line of the cut. As you feed the panel into the blade, the cleat rides along the guide arm and you get a straight, square cut.

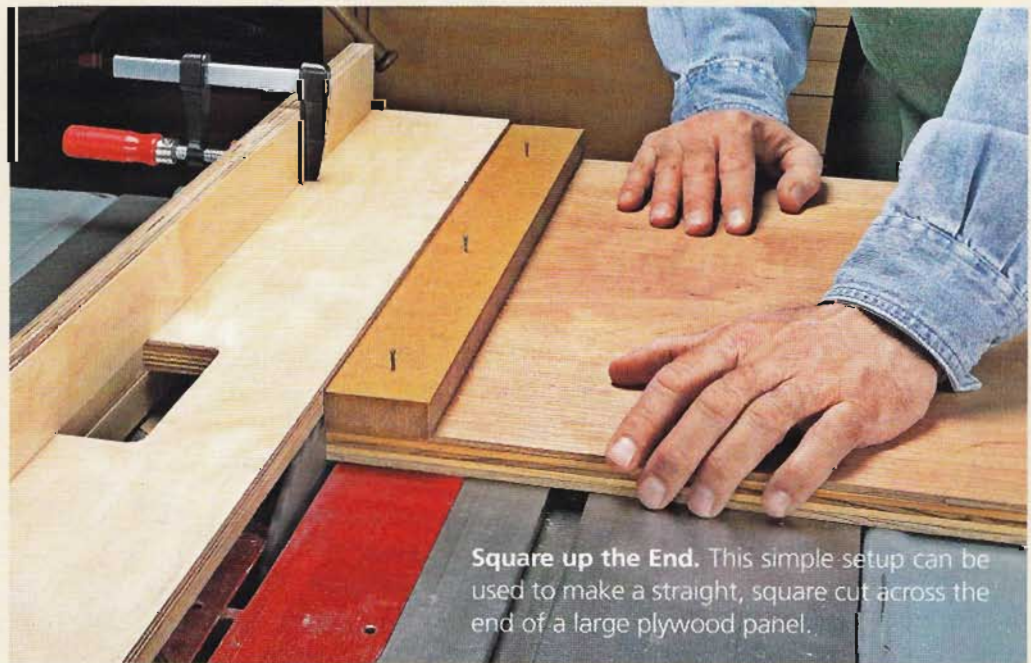

Square up the End. This simple setup can be used to make a straight, square cut across the end of a large plywood panel.

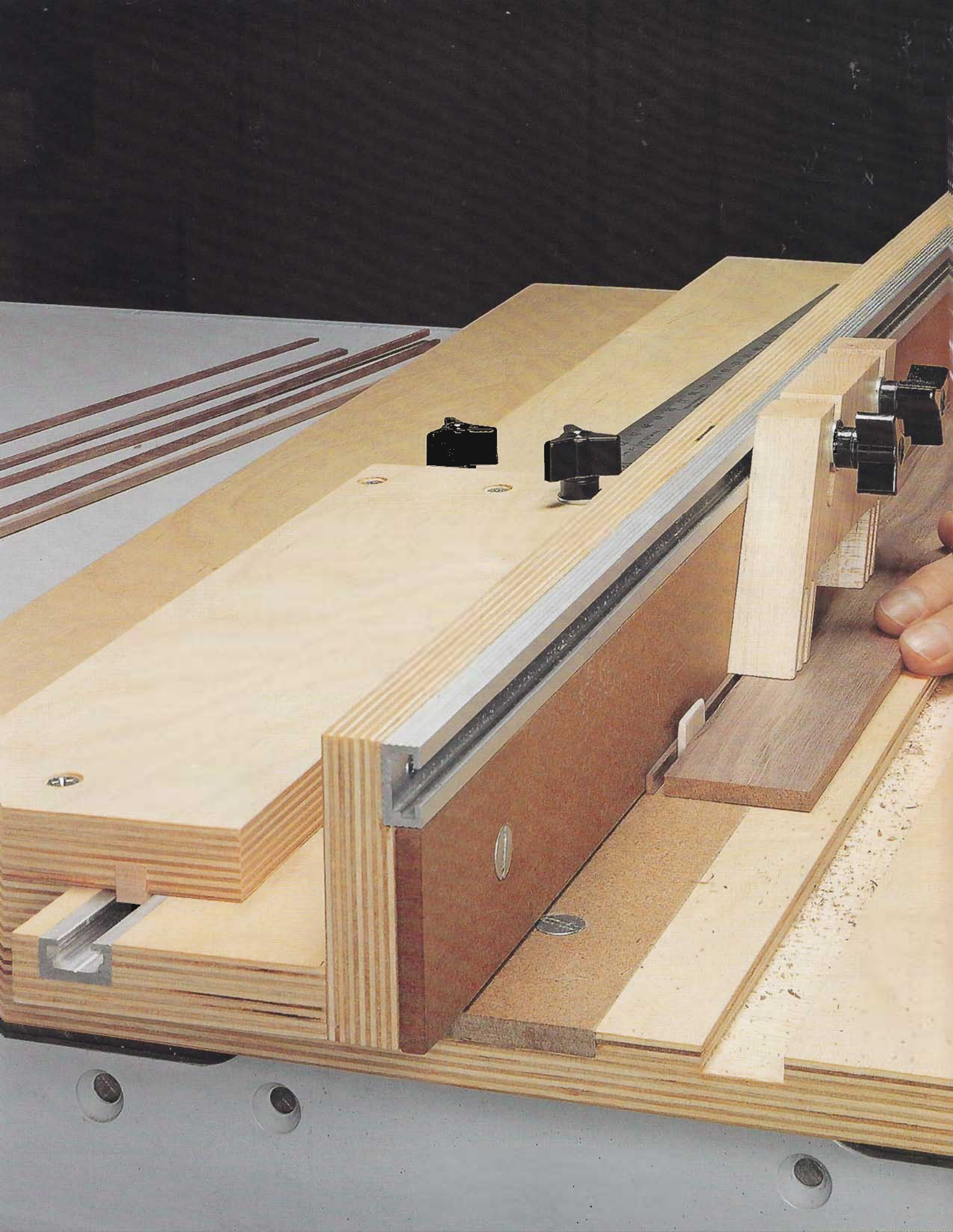



Jigs & Accessories

Get even more from your table saw by building your own jigs and accessories. These projects don't require much time or money, but they make your table saw more versatile than ever.

PRECISION CROSSCUT SLED..... 52

RIP FENCE ACCESSORY SYSTEM 60

SMALL PARTS JIG 66



Zero-Clearance Base. Whether you're making a simple crosscut or cutting dados or box joints, the adjustable base ensures less chipout.

Add-On Accessories. The versatile fence design allows you to easily add accessories like a featherboard, stop blocks, or a box joint attachment.

Precision Crosscut Sled

With this must-have table saw jig, you'll always get chip-free crosscuts. Plus, a versatile fence for accessories increases its cutting capability.



When crosscutting on the table saw, I like the foolproof accuracy a shop-made sled provides. A solid but lightweight sled, like this one, makes cutting longer and wider workpieces easier.

The rock-solid fence design of this sled means you'll get straight, square cuts every time. And it's designed so you can add a variety of accessories, like a flip stop, ruler, and the box joint jig shown in the lower left photo.

But this sled has another unique feature — a “zero-clearance” base. The sliding base extension allows the sled to hug both sides of the blade. That means you'll get cuts that are cleaner with less chipout.

With all these features, this sled is sure to become one of your favorite table saw jigs and one that's likely to stay on your saw most of the time. Turn the page to get started.

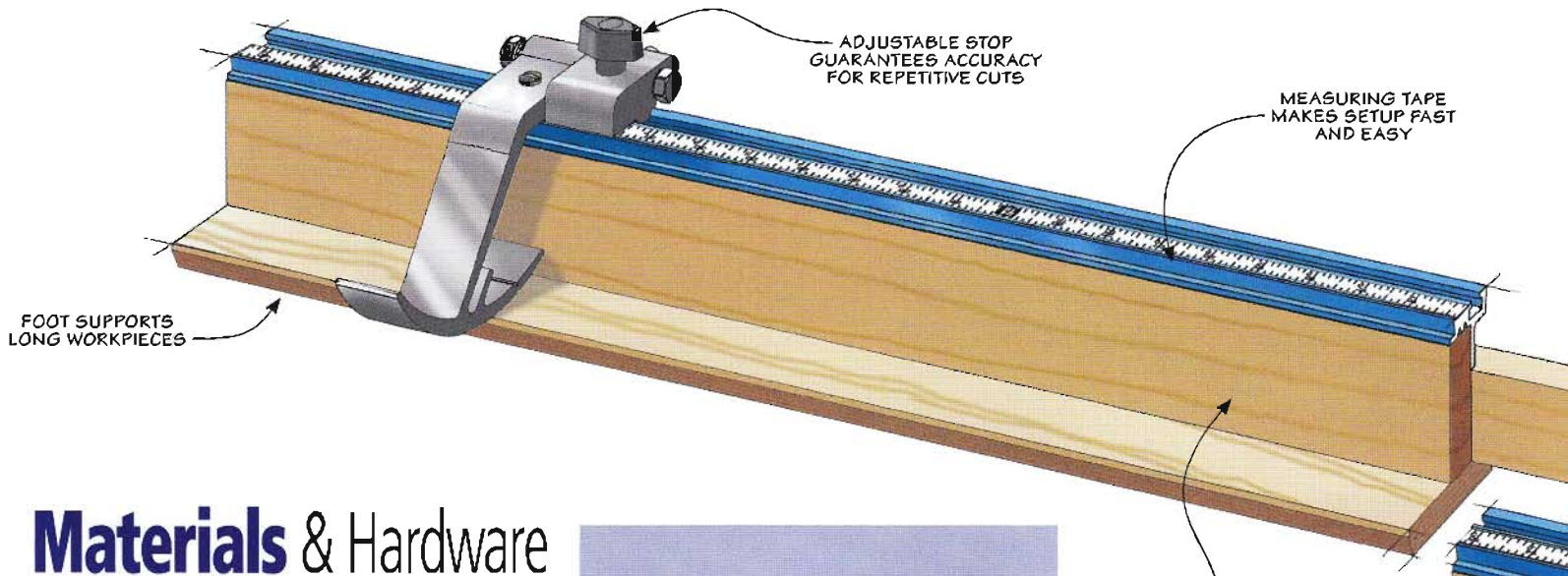

Materials & Hardware

- A Base (1) $\frac{1}{2}$ ply. - $16\frac{1}{2} \times 18$
- B Rear Fence (1) $\frac{3}{4} \times 2\frac{1}{4}$ - 24
- C Front Fence (1) $\frac{3}{4} \times 2\frac{1}{4}$ - $13\frac{1}{2}$
- D Sliding Base (1) $\frac{1}{2}$ ply. - $16\frac{1}{2} \times 5\frac{7}{8}$
- E Adjustment Blocks (2) $\frac{3}{4} \times 1\frac{1}{2}$ - $5\frac{7}{8}$
- F Guard (1) $\frac{1}{4}$ plastic - $3\frac{1}{8} \times 5$
- G Fence Rail (1) $\frac{3}{4} \times 1\frac{1}{2}$ - 42
- H Fence Face (1) $\frac{3}{4} \times 2\frac{1}{4}$ - 24
- I Fence Foot (1) $\frac{1}{2}$ ply. - 3×24
- J Top (1) $\frac{3}{4} \times 1\frac{1}{2}$ - 8*
- K Face (1) $\frac{3}{4} \times 4\frac{1}{4}$ - 8*

- (1) $\frac{3}{8} \times \frac{3}{4}$ - 20" Aluminum Miter Bar
- (3) #8 x $\frac{5}{8}$ " Fh Woodscrews
- (10) #8 x $1\frac{1}{4}$ " Fh Woodscrews
- (2) 24" Aluminum Fence Tracks w/Screws

- (1) Flip Stop
 - (1) 4' Measuring Tape (Left-to-Right)
 - (4) $\frac{1}{4}$ "-20 Knobs w/Insert
 - (4) $\frac{1}{4}$ "-20 x $1\frac{3}{4}$ " Threaded Rods
 - (4) $\frac{1}{4}$ " Washers
 - (4) $\frac{1}{4}$ "-20 Threaded Inserts
 - (2) #6 x $\frac{5}{8}$ " Rh Woodscrews
 - (1) Micro-Adjuster*
 - (1) $\frac{1}{4}$ "-20 x $1\frac{1}{2}$ " Hex Bolt*
 - (1) $\frac{1}{4}$ " Washer*
 - (1) Knob with $\frac{1}{4}$ "-20 Insert*
 - (1) $\frac{1}{4}$ "-20 Cross Dowel*
 - (2) $\frac{1}{4}$ "-20 Threaded Inserts*
 - (2) $\frac{1}{4}$ "-20 x 1" Fh Machine Screws*
- * Indicates items for optional box joint jig shown in the drawing below

FENCE EXTENSION ALLOWS ACCURATE CUTS ON LONG WORKPIECES

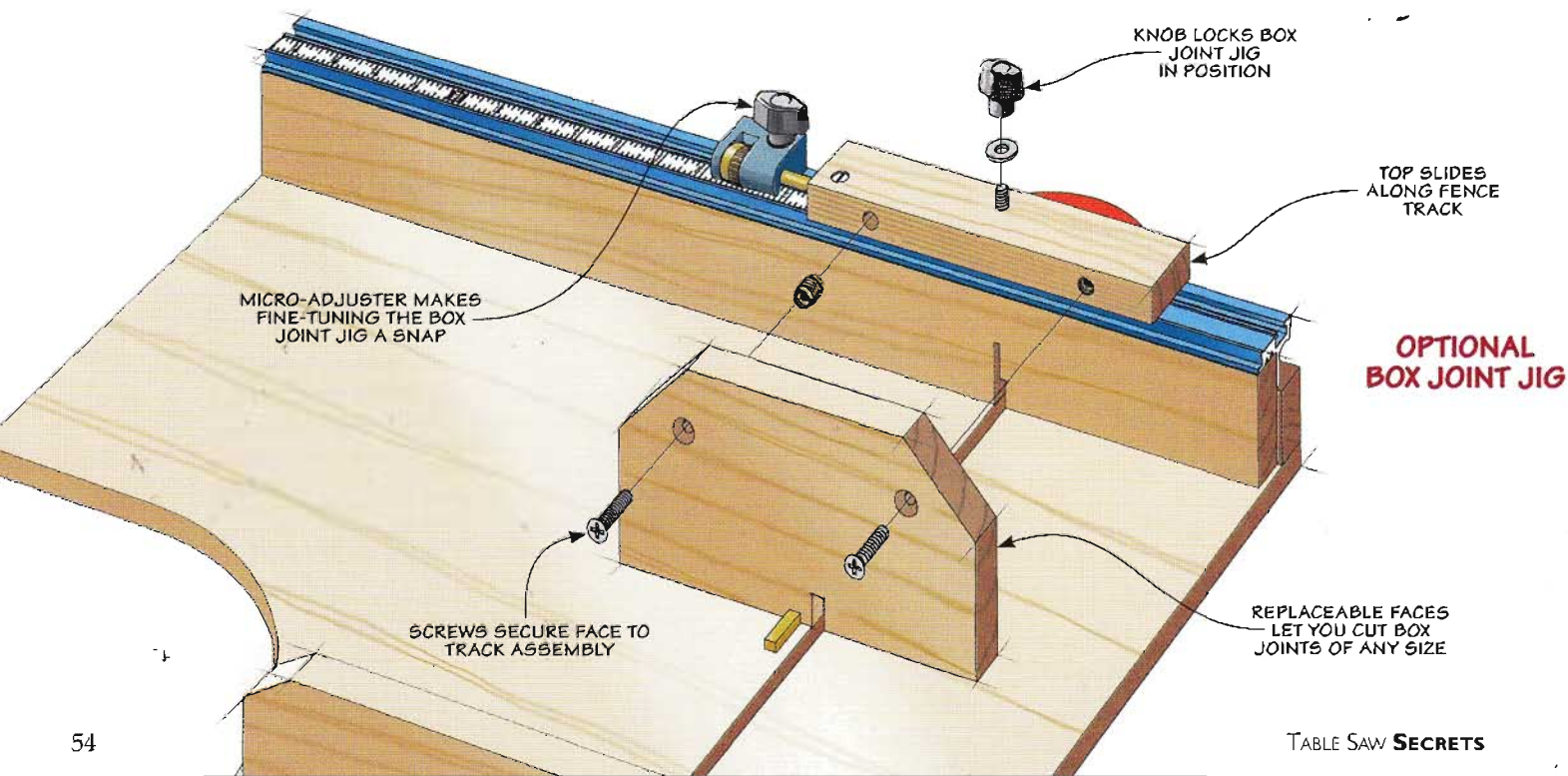

Exploded View Details

OVERALL DIMENSIONS:
21⁵/₈" D x 24" W x 5" H
(WITHOUT FENCE EXTENSION)

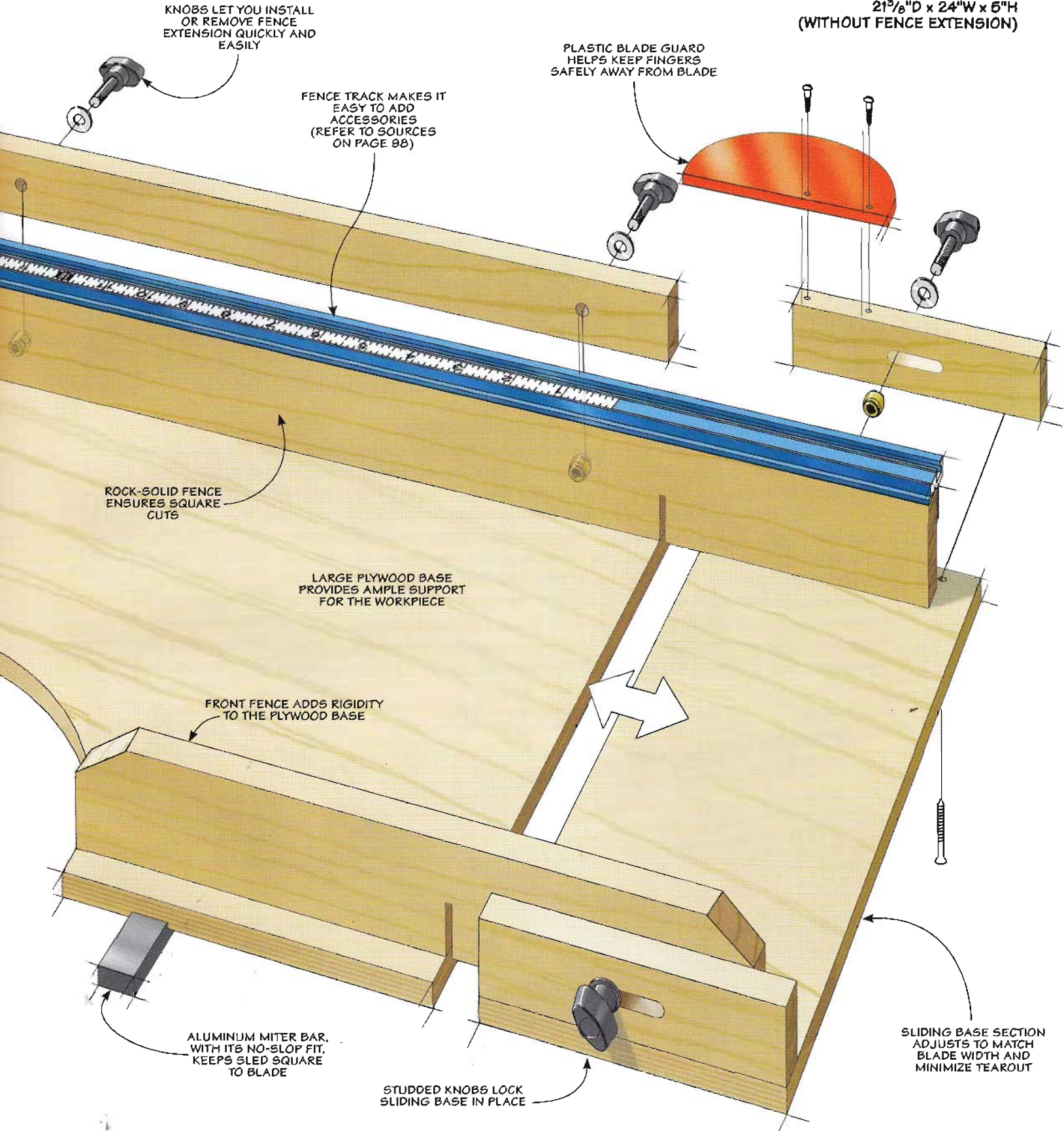

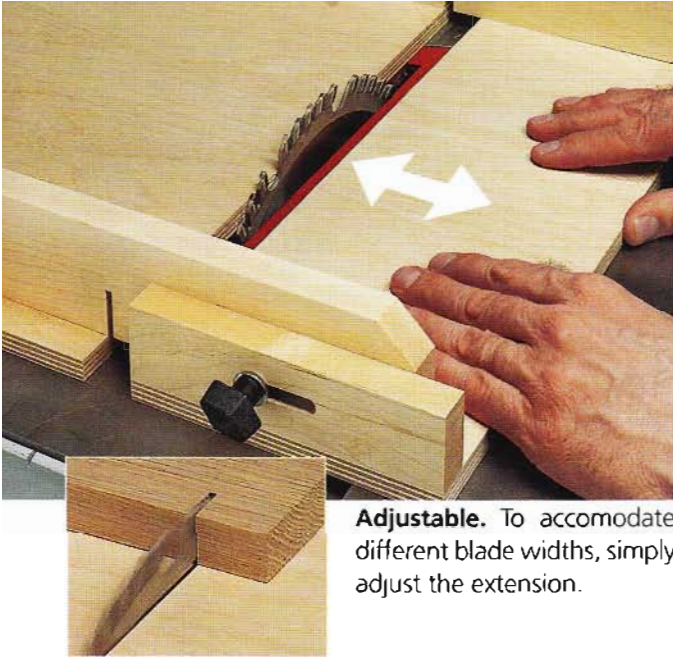

Adjustable. To accommodate different blade widths, simply adjust the extension.

Rock-Solid Base & Fence

The foundation of the sled is a plywood base upon which the workpiece rests. A miter bar is attached underneath. On top of the base, you'll add the front and rear fences. To finish up, add the fence track, measuring tape, blade guard, and flip stop. The result is a solid, accurate sled.

Before you start, I need to mention a few things. This sled was designed for a right-tilt table saw.

If your blade tilts left, make a mirror image of the sled. This allows the sliding base to accommodate a wide range of dado blade widths, as in the photos above.

Also, take the time now to tune up your saw. You want to make sure the blade and rip fence are parallel to the miter slots (refer to page 8). Doing this now will help make sure accuracy is built into the crosscut sled.

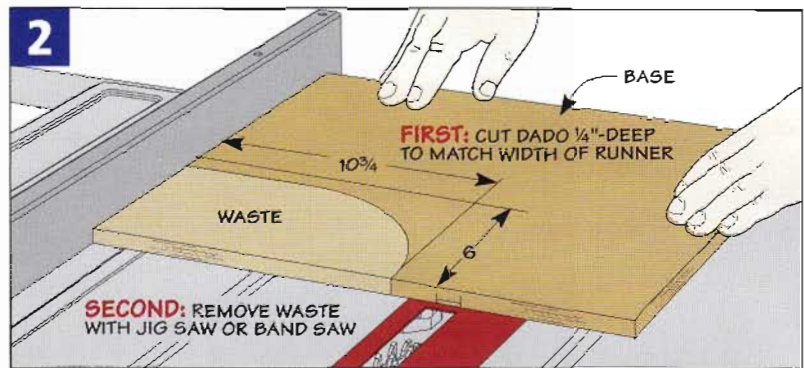
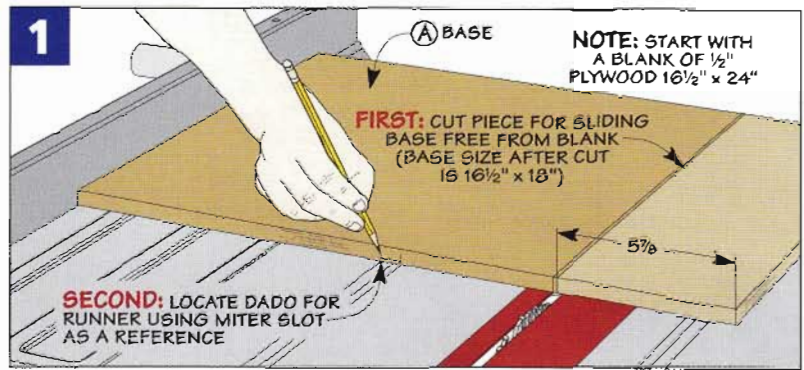

SLED BASE

The fixed and sliding bases are cut from a single blank. When cutting the blank to size, I made sure the sides were perfectly square. Doing this is important because you'll use the rip fence to locate and cut the dado for the runner. And you'll use the front and back edges to determine the location for the fences later.

SLIDING BASE. The first thing you need to do is cut the piece for the sliding base from the blank and set it aside (Figure 1). Without moving the rip fence, mark the location for the runner using the edges of your saw's miter slot as a reference.

FIXED BASE. Once you've cut the dado for the runner, you can go ahead and cut the curved cutout, as shown in Figure 2. Finally, attach the runner and adjust it for a smooth, sliding fit in your saw's miter slot.

FENCE BLANK. Now you can work on the front and rear fences you see in Figure 3. To make both fences, start with a long blank ripped to width and cut the fences to size. Then cut off the corners of the front fence (Figure 3).

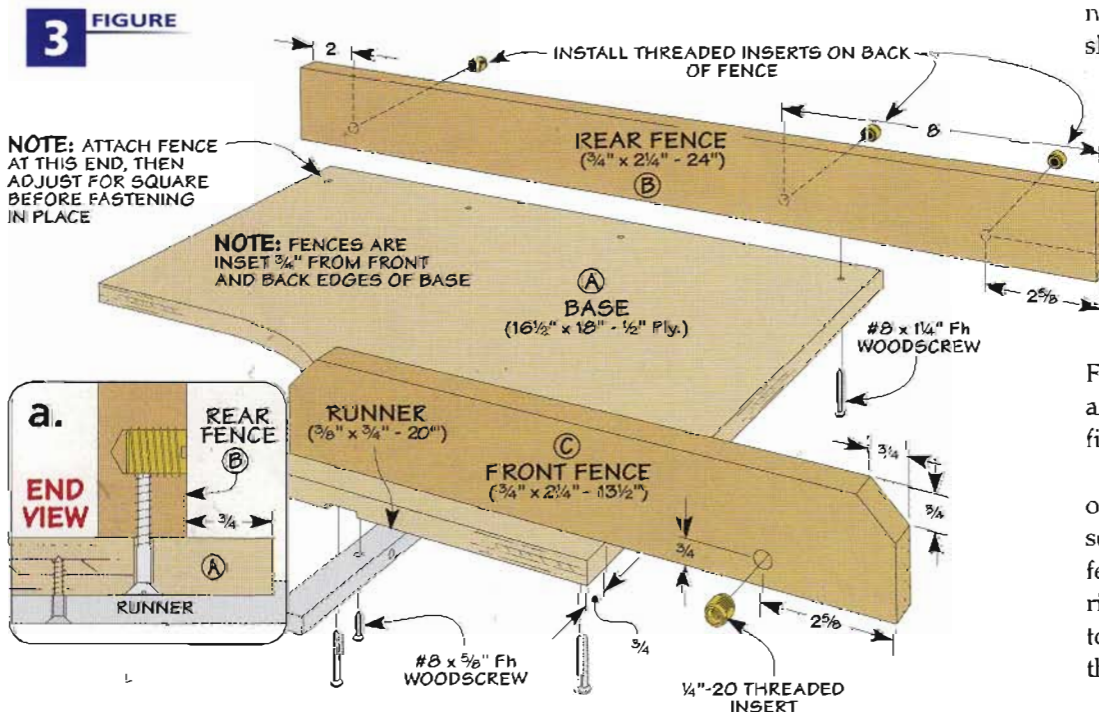

INSERTS. You'll want to install the threaded inserts before attaching the fences to the base. Doing this now rather than later makes it much easier. The inserts are used for adjusting the sliding base and attaching the fence extension that you'll be making later.

ADDING THE REAR FENCE. If you take a look at Figures 3 and 3a, you'll see that the fences are inset a little from the edges of the base. This space provides room for the adjustment blocks used to position the sliding base.

You'll want to take extra care when you're installing the rear fence because the accuracy of the sled depends on the rear fence being square to the blade. To ensure that it's square, I fastened the fence to the sled with one screw at the far end of the sled. Then after squaring it up, fasten the fence at the opposite end with one screw and make some test cuts. Once everything checks out, add the remaining screws to lock it down to the base.

FRONT FENCE. The front fence gets installed next. The important thing to keep in mind here is that it needs to be parallel to the rear fence so the extension can freely slide in and out.

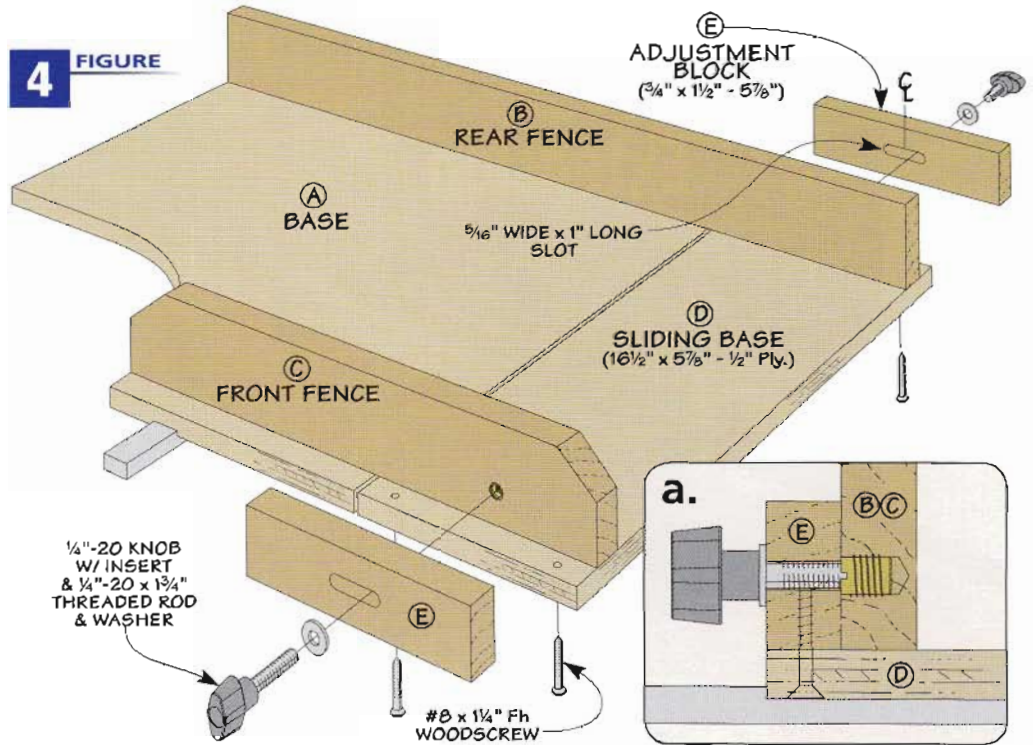

SLIDING BASE & DETAILS

Now, turn your attention to the sliding base (Figure 4). You just need to add the two adjustment blocks. The slots allow the sliding base to hug the blade as you're crosscutting. When you fasten the blocks to the sliding base, they'll sit flush with the front and back edges of the base (Figure 4a).

Adding a little hardware comes next. Make the studded knobs to ensure they're just the right length

to engage the threaded insert. To do this, use a dab of epoxy to lock the threaded rod into the knob.

FINAL DETAILS. To finish up the rear fence, you'll add a commercial fence track, measuring tape, flip stop, and finally, the blade guard (Figure 5). At this point, you have a fully functional sled that's sure to become a mainstay in your shop. The next page shows how to make a fence extension that increases the capacity of the sled.

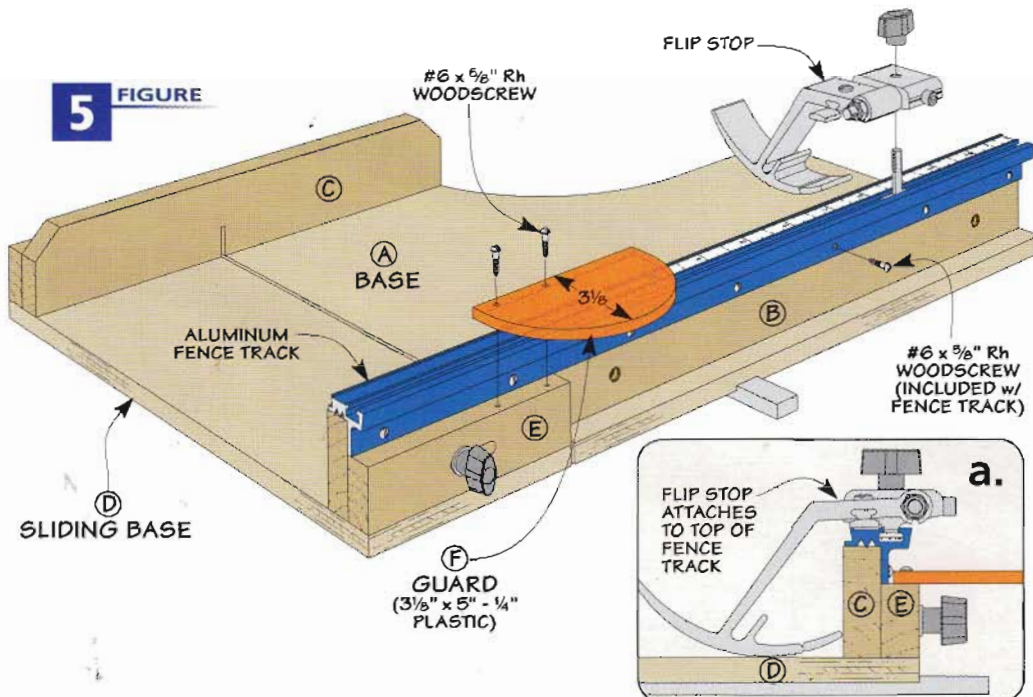

Blade Guard. The guard helps to keep your fingers away from the spinning blade as it exits the sled.

Adding the Fence Extension



Long-Reaching Support. The fence extension gives you the capability to accurately cut long workpieces with ease.

The crosscut sled by itself is a great addition to any table saw. But for cutting longer workpieces, this add-on fence extension lends a hand. When making precise cuts, the extra length plus the “foot” on

the extension both work to support a long workpiece. The extension mounts to the sled’s fence with studded knobs.

START AT THE RAIL Figure 6 shows you how the fence extension is put together. I started with the fence rail. It’s the “backbone” of the extension. After cutting it to size, you can drill the oversized holes for the studded knobs.

FENCE FACE. The fence extension’s face is just like the one on the sled’s rear fence. The only difference is the addition of the foot. After cutting the face to final size, you cut the foot with its beveled

front edge. (This helps the fence slide over your saw’s table).

To make assembly easier and eliminate gaps between the sled’s fence and the extension, fasten the fence rail to the sled first. Then just butt the end of the foot against the sled and fasten it to the rail. You can do the same with the fence face. Finally, install the fence track along the top edge, and add the measuring tape.

HANDY HELPER. After making a few cuts with this sled, you’ll wonder how you got along without it. But to make it even more useful, take a look at the opposite page.

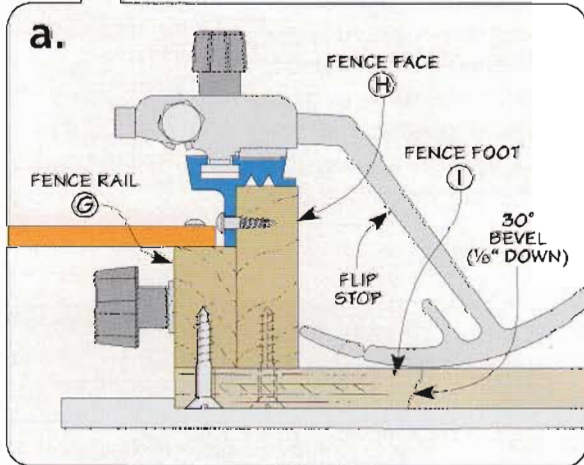

6 FIGURE

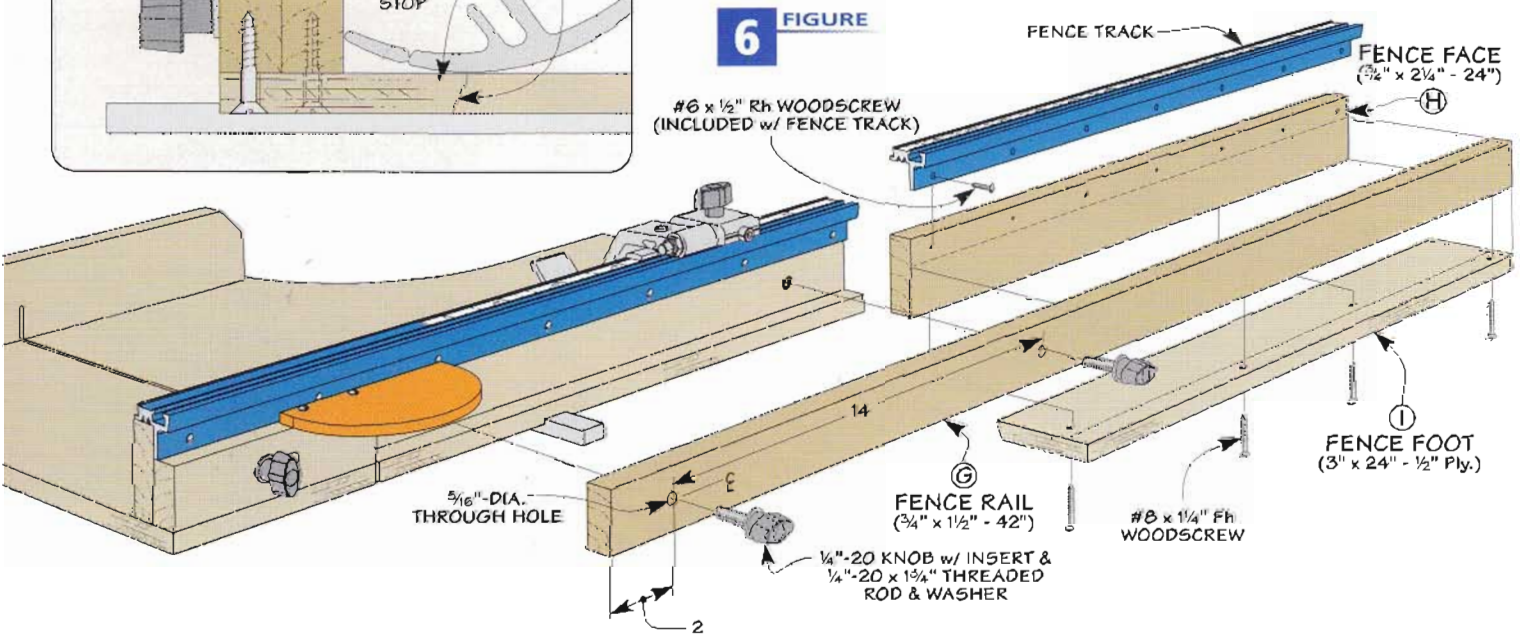

Box Joint Attachment

The crosscut sled makes an ideal platform for cutting box joints, as shown in the photo. It's easy to make and takes the "trial and error" out of cutting box joints.

The jig consists of a top piece that slides along the fence track. The micro-adjust mechanism takes the guesswork out of cutting box joints by allowing you to fine-tune its position. Finally, interchangeable faces make it easy to cut a wide range of box joint sizes.

Micro-Adjustment. It's best to start with the top piece so you can accurately fit the micro-adjuster (drawing below). You can cut the top to length, but leave it a little wide to make it easier to locate the holes for the cross dowel that accepts the stud on the adjuster.

To do this, install the micro-adjuster on the fence track. Now place the oversized top piece on top of the track, overlapping the front and back edges. Use the threaded stud of the micro-adjuster to locate the holes for the stud and cross dowel (detail 'a'). With these holes drilled and the cross dowel

in place, go ahead and thread the micro-adjuster into the dowel. Next you can mark the width of the top using the fence edges as a guide and rip the top to width. Finally, after drilling the holes for the adjustment knob and inserts, thread the inserts in place.

Jig Face. Now you're ready to work on the face of the jig. There are only a couple of things you need to do here. First, drill countersunk holes for machine screws that fasten the face to the top. Then you'll need to cut a notch so you can glue the index key in place. (The width of the notch and key determine the size of the box joints.) The great thing is you can make a separate face for each size of box joint you need to cut.

Using the Jig. Using the jig is a simple process. You'll find it's similar to other box joint jigs you may have used. The advantage of this jig, however, is the micro-adjuster. Zero in on the perfect fit of your box joint just by turning the knurled knob. And in no time, you'll be making perfect box joints.

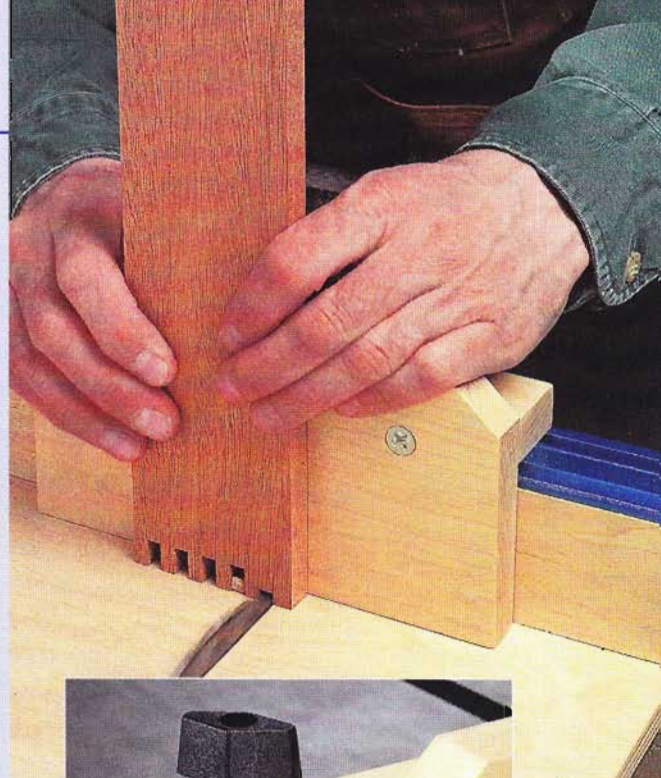

Box Joints. Turn the crosscut sled into a precise box joint jig with this commercial micro-adjuster.

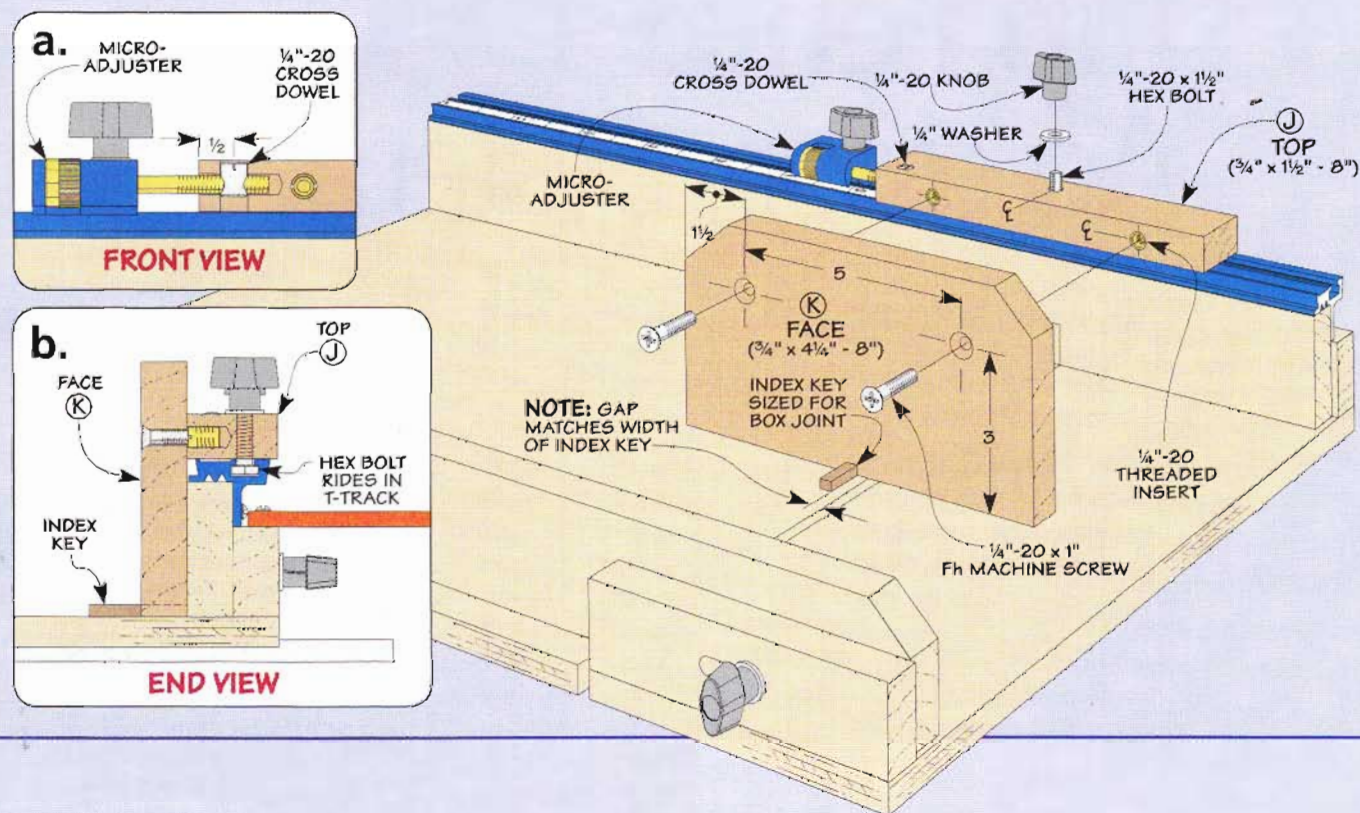



Rip Fence Accessory System

These versatile add-ons increase accuracy, improve safety, and help you get more from your table saw.

If you're anything like me, you use your table saw for more tasks than just ripping and crosscutting. That includes cutting rabbets, grooves, dados, and raised panels, just to name a few. To do these things well, I often attach some sort of accessory to the rip fence. These one-time solutions work, but there's usually a clamp or two that gets in the way.

The accessory system you see here eliminates this problem. It starts with a platform that's attached to

your rip fence, and it accepts several handy add-ons. There's a stop for making short crosscuts, a plate for attaching featherboards, and a dual-purpose fence for rabbets and wide workpieces. Finally, there's a dust-collecting blade cover to pull away chips and dust right at the source.

Each accessory attaches quickly — so you're more likely to use it. And you can make the whole set in just a few hours. You'll find it's time well spent.

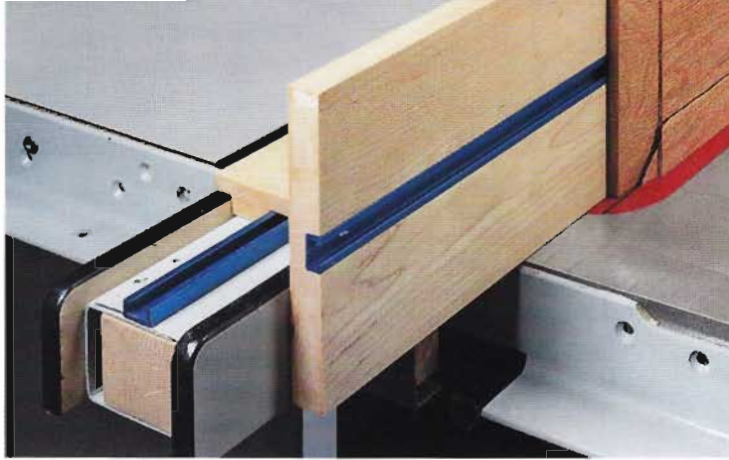

Tall Fence. It only takes a few seconds to attach a tall fence for greater control when cutting a wide or tall workpiece on edge. This comes in handy when making a raised panel, for instance.



Featherboards & Hold-Downs. Adding featherboards to the rip fence accessory plate makes it a snap to cut rabbets, dados, and grooves to a uniform depth.

Exploded View Details

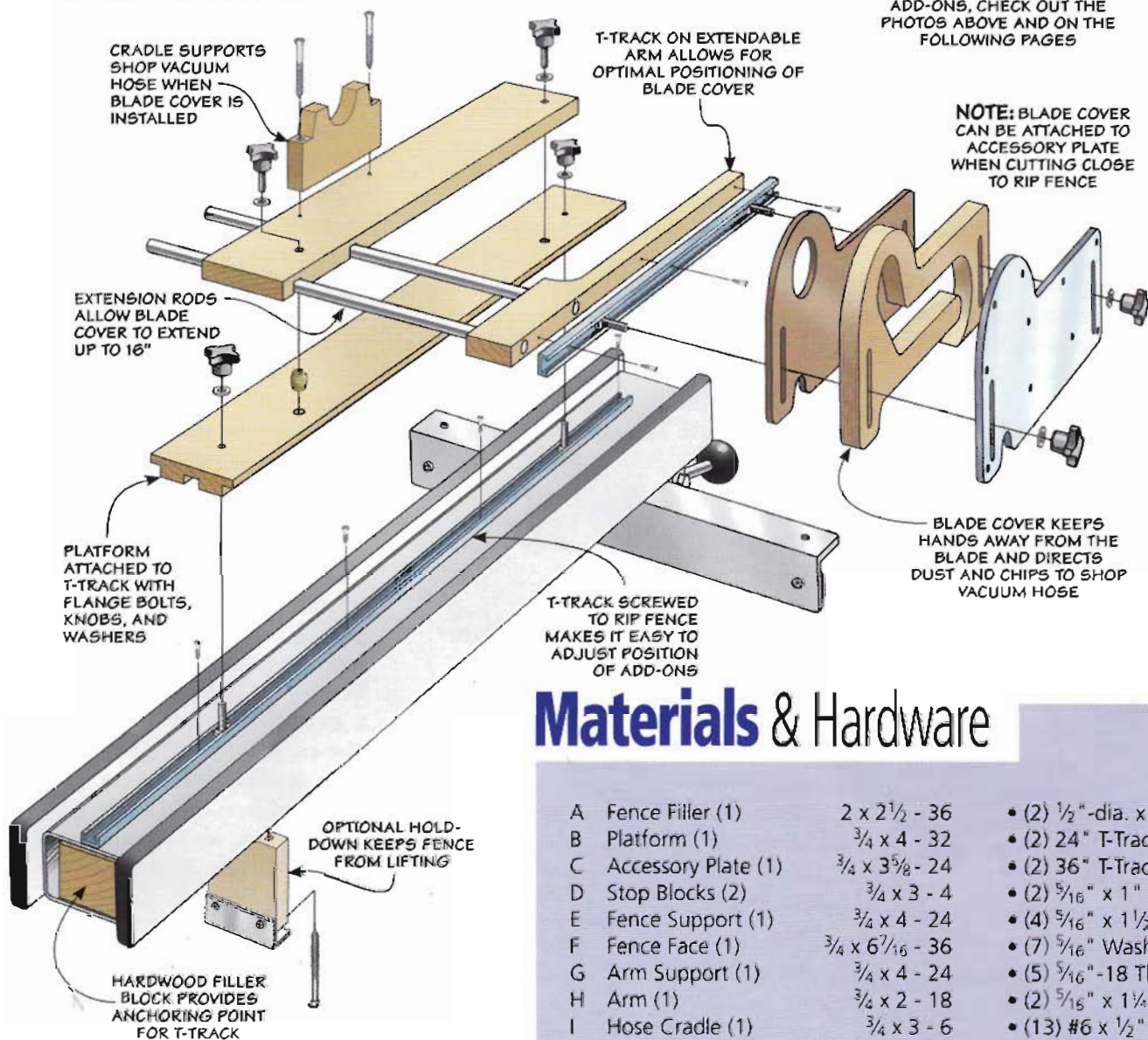

Materials & Hardware

A	Fence Filler (1)	2 x 2 $\frac{1}{2}$ - 36	• (2) $\frac{1}{2}$ "-dia. x 18" Steel Rod
B	Platform (1)	$\frac{3}{4}$ x 4 - 32	• (2) 24" T-Track
C	Accessory Plate (1)	$\frac{3}{4}$ x 3 $\frac{5}{8}$ - 24	• (2) 36" T-Track
D	Stop Blocks (2)	$\frac{3}{4}$ x 3 - 4	• (2) $\frac{5}{16}$ " x 1" Flange Bolt
E	Fence Support (1)	$\frac{3}{4}$ x 4 - 24	• (4) $\frac{5}{16}$ " x 1 $\frac{1}{2}$ " Flange Bolt
F	Fence Face (1)	$\frac{3}{4}$ x 6 $\frac{7}{16}$ - 36	• (7) $\frac{5}{16}$ " Washers
G	Arm Support (1)	$\frac{3}{4}$ x 4 - 24	• (5) $\frac{3}{16}$ "-18 Threaded Knob
H	Arm (1)	$\frac{3}{4}$ x 2 - 18	• (2) $\frac{5}{16}$ " x 1 $\frac{1}{4}$ " Studded Knob
I	Hose Cradle (1)	$\frac{3}{4}$ x 3 - 6	• (13) #6 x $\frac{1}{2}$ " Fh Woodscrews
J	Blade Cover Core (1)	$\frac{3}{4}$ ply. - 7 x 14	• (2) #8 x 2 $\frac{1}{2}$ " Fh Woodscrews
K	Blade Cover Back (1)	$\frac{1}{4}$ ply. - 7 x 14	• (10) #6 x 1" Fh Woodscrews
L	Blade Cover Frt. (1)	$\frac{1}{4}$ poly. - 7 x 14	• (2) #8 x 2" Fh Woodscrews
			• (2) #8 x 1 $\frac{1}{2}$ " Fh Woodscrews
			• (2) $\frac{5}{16}$ "-18 Threaded Inserts

Start with the Mounting Platform

One of the benefits of this system is that the accessories are easy to attach and remove from the rip fence. Since each add-on is a different size and serves a different purpose, the mounting method is designed to be flexible, as well. Note: This system is designed for a T-square-style rip fence.

FIXED ASSEMBLY

In general, each accessory attaches to a platform that's mounted on top of the rip fence. You can see how this works in Figure 1. A set of threaded inserts allows the accessories to be installed with a few twists of a pair of studded knobs.

To make it easy to secure the platform, it locks to a length of T-track. And that's where you start making this accessory system.

GUIDE TRACK. The T-track is screwed to the top of the main tube of the rip fence. For a secure

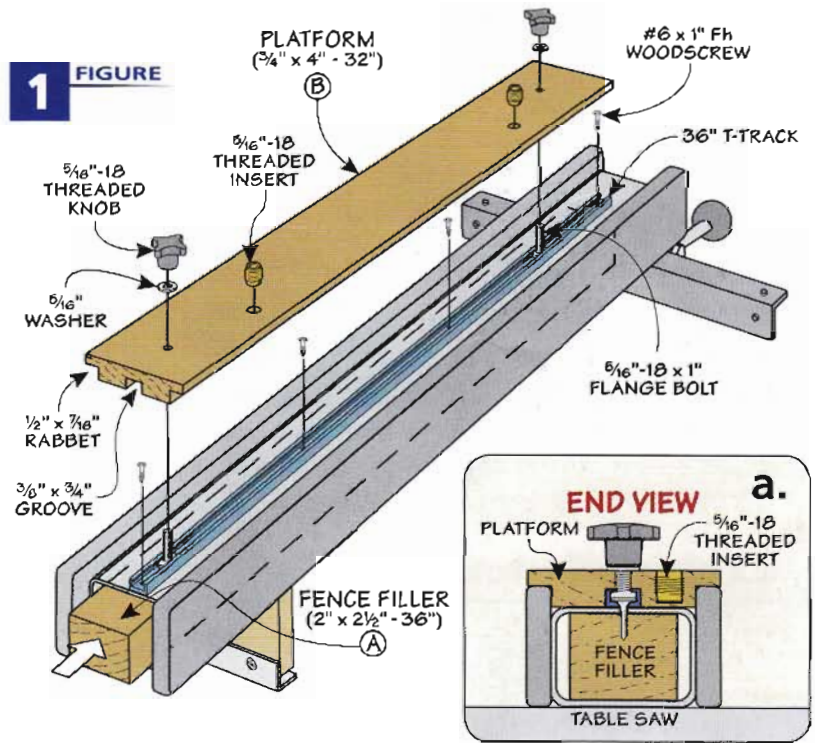

connection, I anchored the T-track to a hardwood filler that I cut to fit inside the fence, as shown in Figure 1a. This also means you need to drill a few holes in the rip fence for the screws.

You can do this with a hand drill and a twist bit. But there are a few things to keep in mind. First, you'll need to use a punch

to create a dimple so the bit won't wander. Then, concentrate on keeping the bit square as you drill. It's also a good idea to use a light machine oil to draw out the chips and keep the bit cool.

The filler piece is sized to fit easily into the fence tube. I didn't want to have to pound it in place.

MOUNTING PLATFORM. To provide a place for adding the accessories, I made a platform that attaches to the guide track. The important thing about sizing this piece is that it should match the width of your rip fence. Then there are several details to work on.

RABBETS & GROOVE. The first thing to do is cut a pair of rabbets and a groove along the bottom face. The rabbets are cut so the platform nestles around the fence faces and rests on the top of the tube, like you see in Figure 1a. In a similar fashion, I cut a groove to accept the T-track.

The next task is to drill some holes. The first pair line up with the T-track and allow the platform to lock in place with flange bolts, washers, and knobs. Another pair in the platform accepts threaded inserts. These will be used to mount the accessories you'll build later on.

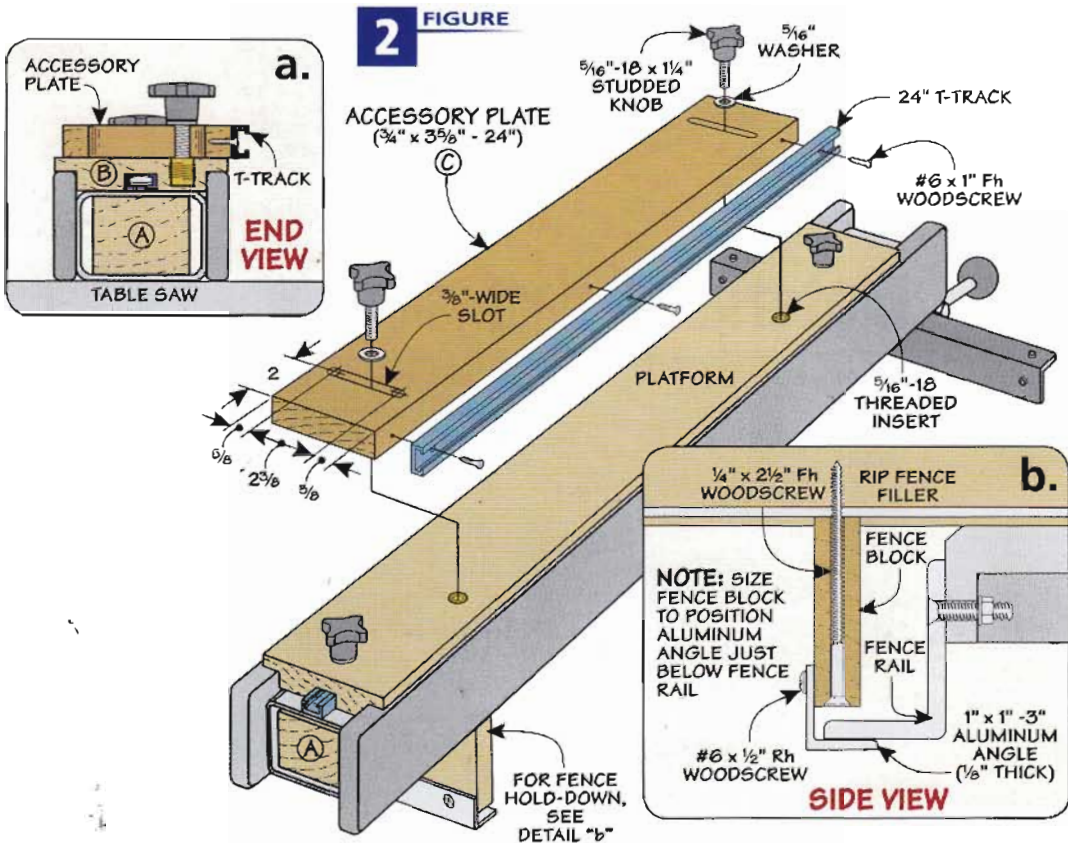

This takes care of the “fixed” portion of the accessory system. You can now attach the platform to the T-track and get started on making the accessories.

ACCESSORY PLATE

As I mentioned earlier, it’s not easy to clamp some accessories, like featherboards, to a rip fence. So the first thing I added to the platform was an adjustable accessory plate (Figure 2).

The accessory plate is a board with a slot cut in it near each end. The slots allow the plate to be adjusted in and out. Along one edge, there’s a length of T-track. This makes it easy to attach a shop-built or commercial featherboard and adjust it to provide pressure in the right location.

STOP BLOCK. The accessory plate also accepts shop-built add-ons, like the one in the upper right photo. Used along with the miter gauge, it serves as an end stop for crosscutting short pieces from a long blank. This way, when the piece is cut free, it won’t bind between the rip fence and blade.

The adjustable stop consists of two identical pieces of hardwood that are screwed together in an “L” shape (End View detail above). A knob and flange bolt makes it easy to mount the stop to the accessory plate.

TALL FENCE

Besides a featherboard and stop blocks, I often attach an auxiliary fence to my table saw’s rip fence. In the past, I’ve used two kinds of auxiliary fences.

One version was a sacrificial fence for rabbeting. This fence allowed me to “bury” an extra-wide dado blade in the fence.

The other was a tall fence for cutting a workpiece on edge. Here, I just needed a wide bearing surface to provide additional control on a workpiece. I used it for making raised panels or cutting grooves in the edge of

Stop Block. Attach this L-shaped stop block to the rip fence system for crosscutting short pieces. Locate the stop ahead of the blade to prevent binding.

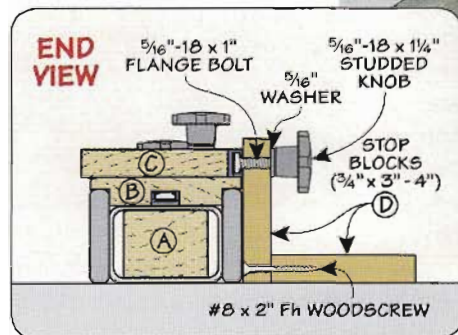
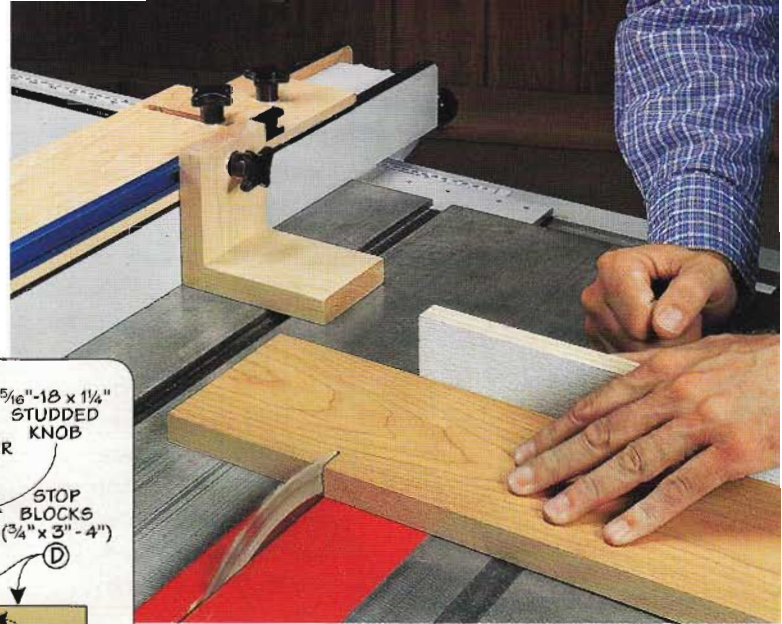

wide pieces. For this rip fence system, I combined the two functions into one accessory.

You can see what I’m talking about in Figure 3. It consists of two pieces. A fence support holds the fence to the platform. This piece is screwed to a tall face piece. Along the center of the face, I cut a groove and installed a length of T-track. As before, this makes it easy to attach a featherboard or other type of hold-down.

What makes this fence a two-in-one design is that the fence is reversible. One edge is flat and smooth. The other edge has a pocket for a dado blade.

To create the pocket, all you need to do is install a wide dado blade in the table saw. Then lower the blade below the table. Slide the auxiliary fence over the insert plate and turn on the saw. Then slowly raise the blade — about 1/2” will cover most of your needs.

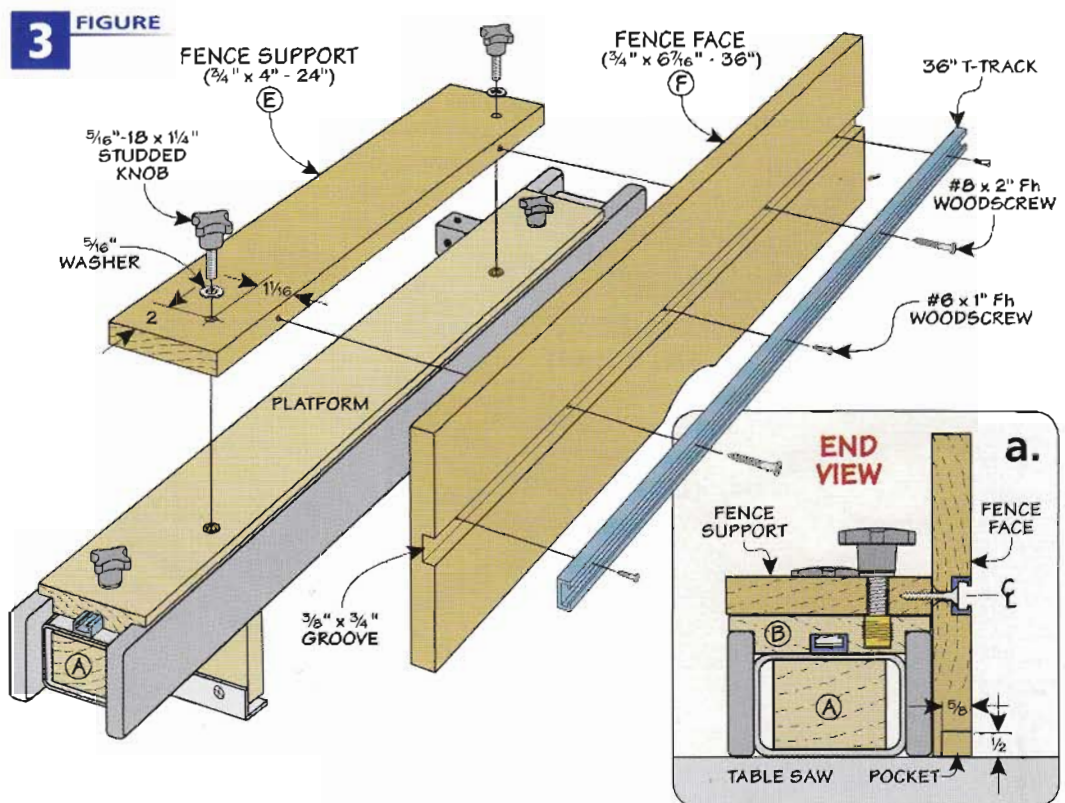

Making the Blade Cover

The final component of the accessory system is a blade cover. It has a couple of advantages over the blade guard and splitter assembly that came with your saw.

The main benefit is that this is just a blade cover. So that means you can use it on non-through cuts like dados and grooves. Note: Because the blade cover doesn't have a built-in splitter, it's a good idea to use an aftermarket splitter or install one in a shop-made zero-clearance insert plate.

The blade cover has one other important feature I like — built-in dust collection capability. Its design allows you to plug in your shop vacuum and collect dust and chips right at the source.

MOUNTING ASSEMBLY. The blade cover actually consists of two sections. First, there's the mounting assembly that connects the cover to the platform on the rip fence. The other section is the three-piece blade cover assembly.



Dust-Free Cutting. This two-in-one blade cover forms a barrier to keep you safe. And it has a built-in port to accept a shop vacuum hose. Adjustment slots let you change the height to match the workpiece.

ARM SUPPORT. You can see what goes into the mounting assembly in Figure 4. The first piece to make is the arm support. It's similar to the accessory plate and fence support you made earlier. But there are a few key differences.

The main difference is the set of dados cut on the bottom face. These accept a pair of steel rods, which let you adjust the position of the blade cover. Just be sure to cut the dados for a snug fit.

The other difference is the hose cradle attached to the top. As you

might guess, it holds the vacuum hose in place when it's plugged into the blade cover.

ARM. Attached to the other end of the steel rods is the final piece of the mounting assembly — the arm. Its curved shape provides clearance when the cover is located close to the rip fence. On the other side, I attached another piece of T-track. This allows you to quickly slide the blade cover on and adjust its position.

BLADE COVER. That brings us to the blade cover assembly. You can see

4 FIGURE

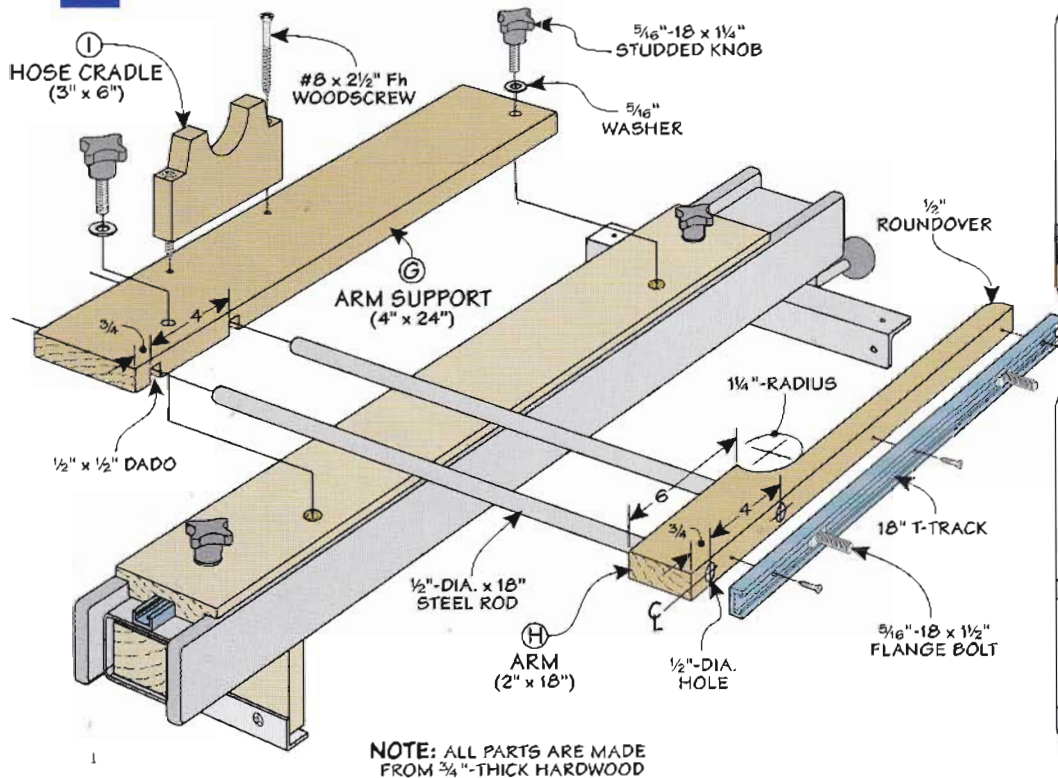

NOTE: ALL PARTS ARE MADE FROM 3/4\"-THICK HARDWOOD

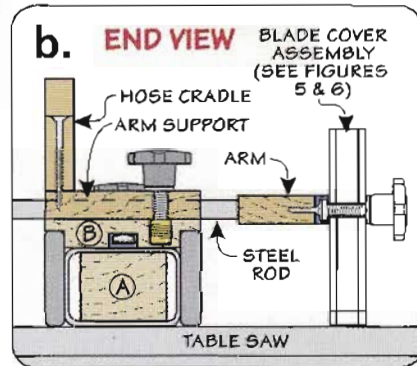
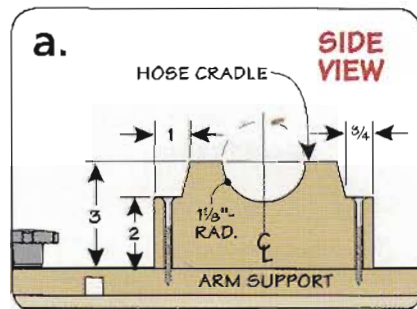

5 FIGURE

NOTE: USE PATTERN BELOW TO LAY OUT AIR PATH AND SLOTS

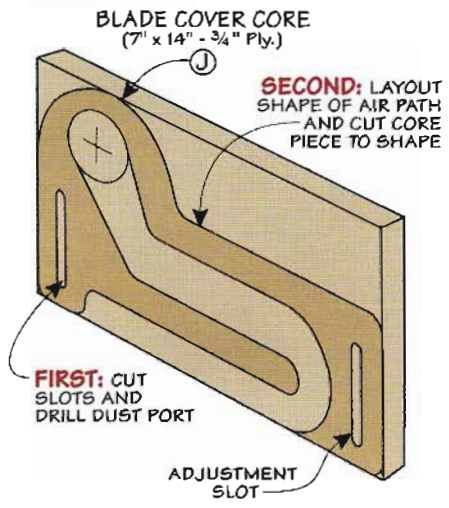

6 FIGURE

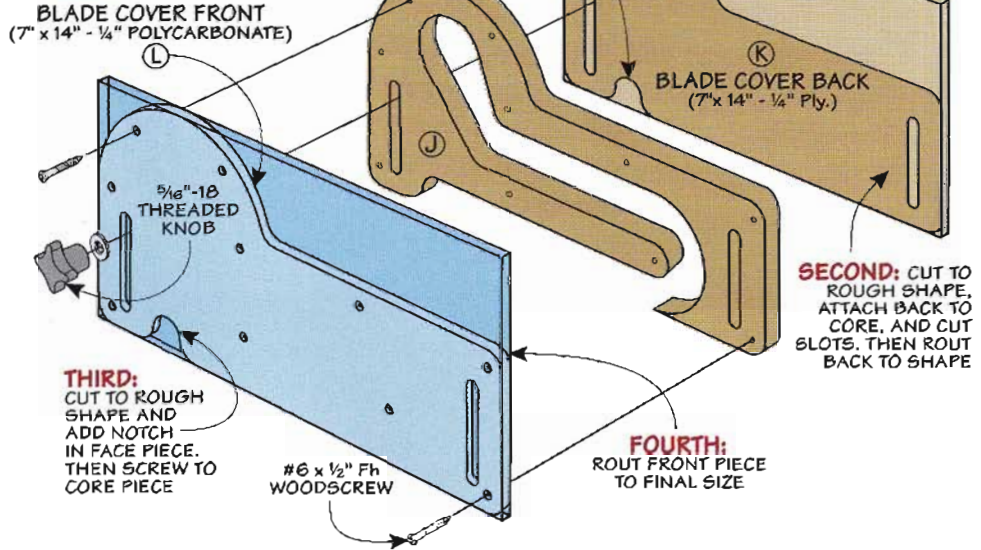

in Figure 6 that it's a sandwich of three layers. Figures 5 and 6 show you the order of construction, so I'll just hit some highlights.

You can start by making the core piece from 3/4" plywood. You'll find it's easier to create the adjustment slots before cutting the core to shape. Then lay out the air path using the pattern below.

From there, you can cut the core to shape at the band saw. I used a 2 1/4"-dia. Forstner bit so

drill out the end of the air path where the shop vacuum hose connects. Now, you're ready to make the faces.

FACES. The faces of the blade cover enclose the air path for dust collection and form a physical barrier to keep your hands away from the blade. The back face is made of 1/4" plywood for a solid connection point for the vacuum hose. I made the front from 1/4" polycarbonate for visibility.

Each face has a notch on the lower edge. This provides adequate airflow for the shop vacuum to be most effective.

To shape the faces, I cut them to rough shape at the band saw. Then, I attached them to the core piece (glue for back, screws for front) and trimmed with a flush-trim bit at the router table.

With these accessories close at hand, you'll find using your table saw is easier than ever.

Blade Cover Core Pattern

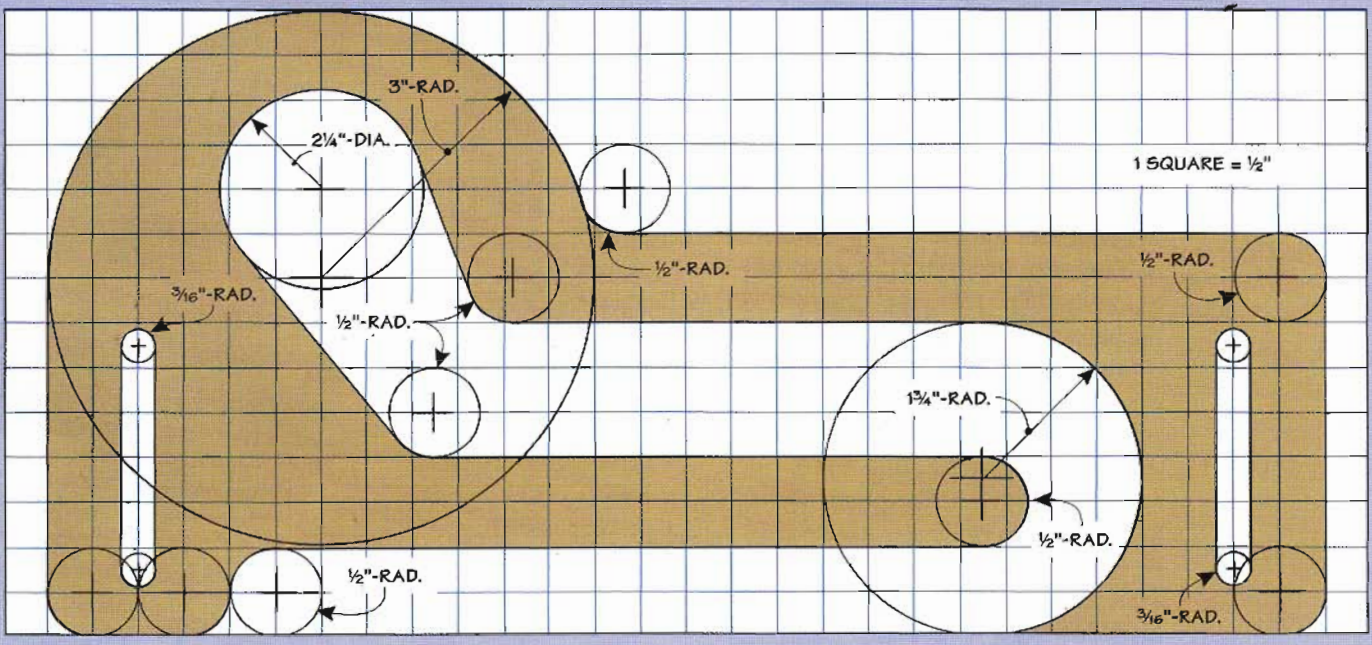

Multi-Purpose Small Parts Jig

This easy-to-build project makes it a snap to cut thin and small parts accurately and safely.

It's no surprise that the table saw handles most of the cutting chores in my shop. It's a powerful and accurate tool for heavy work. But when it comes to cutting very small parts, it's just not as well suited to the task. The reasons for this are simple. First, the rip fence isn't designed for easy adjustment in very small increments (less than $\frac{1}{32}$ "). And even if you can dial in that level of accuracy, you still end up with the problem of controlling a workpiece before, during, and after the cut.

The jig shown in the photo above handles these tasks by incorporating a small-scale "replacement" table in your saw setup. Along with the table comes a couple of handy accessories designed to take you to a whole new level of precision.

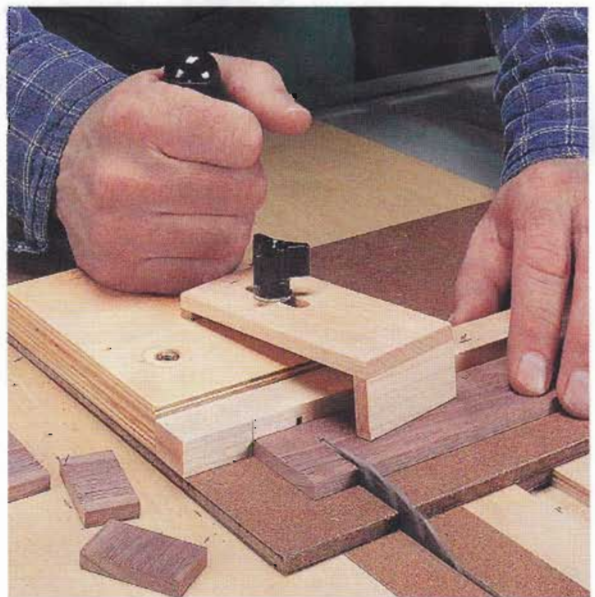

Crosscut Sled. This crosscut sled rides in a slot in the platform for accurate cuts in small parts. A hold-down keeps the workpiece safely in place.

The main feature of this jig is a micro-adjusting rip fence. It consists of two tapered sections that slide against each other. Sliding the adjustable section forward or backward shifts the fence toward (or away from) the blade in very small, repeatable amounts.

Some of the other features included with this jig are a cross-cut sled, a zero-clearance insert, and a unique hold-down.

THE RIGHT BLADE. There's one other component of your table saw to consider when cutting small parts — the blade. I replaced my standard blade with a 40-tooth, 7¼"-dia. combination blade. Using a smaller blade reduces the tooth speed, which makes cutting small pieces smoother and provides more accurate results.

START WITH THE PLATFORM

The jig is made up of three assemblies. It begins with the platform, which serves as a base for the other assemblies: the rip fence and the crosscut sled. What's important here is for the platform to be flat and smooth. To ensure this, I used a piece of Baltic birch plywood for the platform.

THREE GROOVES. There's a little more to the platform than a plain

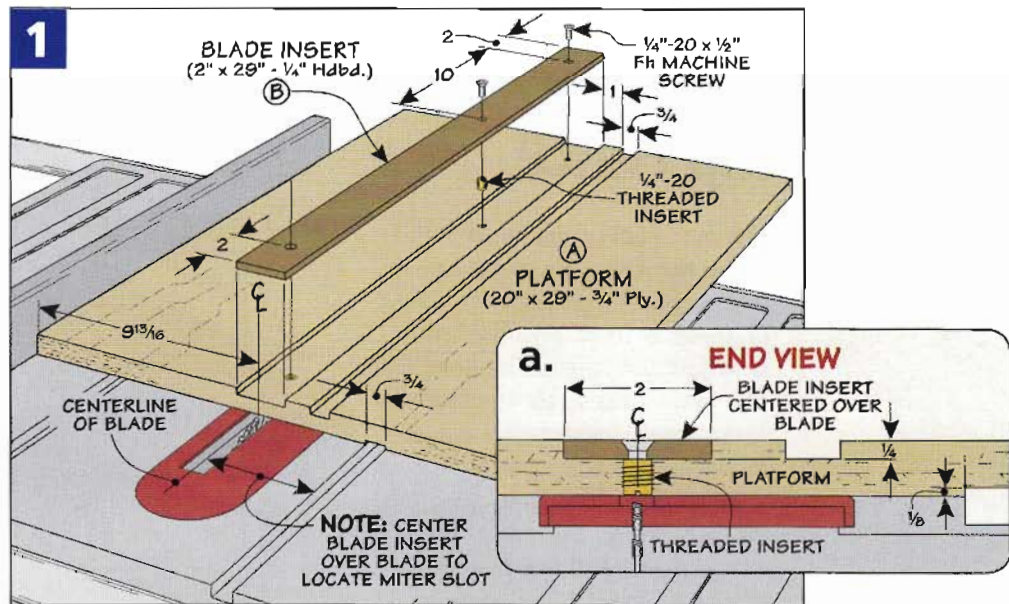

piece of plywood, though. It has three grooves cut in it (Figure 1). A wide groove in the top holds a hardboard insert, which allows you to create a zero-clearance opening for the blade (Figure 1a). A second groove cut in the top serves as a miter gauge slot for the crosscut sled shown on page 71.

The final groove is cut in the bottom face. This groove accepts a runner to register the jig in the miter gauge slot of the saw table.

MITER BAR. With the details of the platform done, you can make a few parts that attach to it. The first

is the miter bar (Figure 2). Size it for a snug fit in the groove and the miter gauge slot in the saw table. Just don't glue it down yet.

HARDBOARD INSERTS. The other part you need to make is the blade insert I mentioned earlier, as you can see in Figures 1 and 2.

Go ahead and make a few of these. The hardboard insert will eventually get chewed up. And you'll use one as a fence insert later on. Finally, Figure 2 shows you how to add a splitter to the insert. This is helpful when ripping very narrow strips.

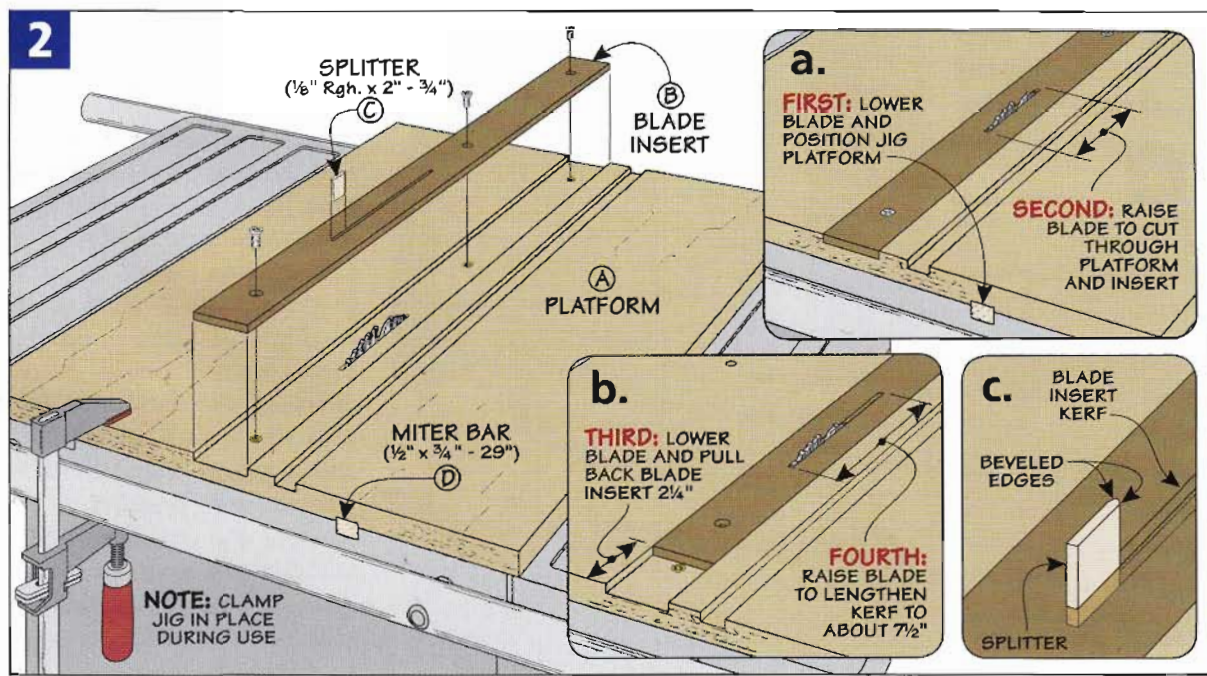

Micro-Adjusting Rip Fence

The next part of the jig to make is the rip fence. It's made up of two, tapered components. One of these is fixed and the other is adjustable to slide against it. The two tapers work together to make small, incremental adjustments easy to accomplish.

SLIDING TAPER. The fixed base of the rip fence assembly registers in a series of notches in the platform. The notches provide a rough adjustment. To fine-tune the position, you move the sliding fence face forward or backward — not side to side.

The key is the long taper on the mating faces of the fence parts I mentioned earlier. If you slide the fence face away from you, it also moves away from the blade a small amount. For example, sliding the rip fence forward 1" moves the fence face away from the blade only $\frac{1}{16}$ ".

TAPERED BASES. Start by making the tapered portions of the rip fence. As you're preparing to make these pieces, the most important thing to keep in mind is that the taper on each edge

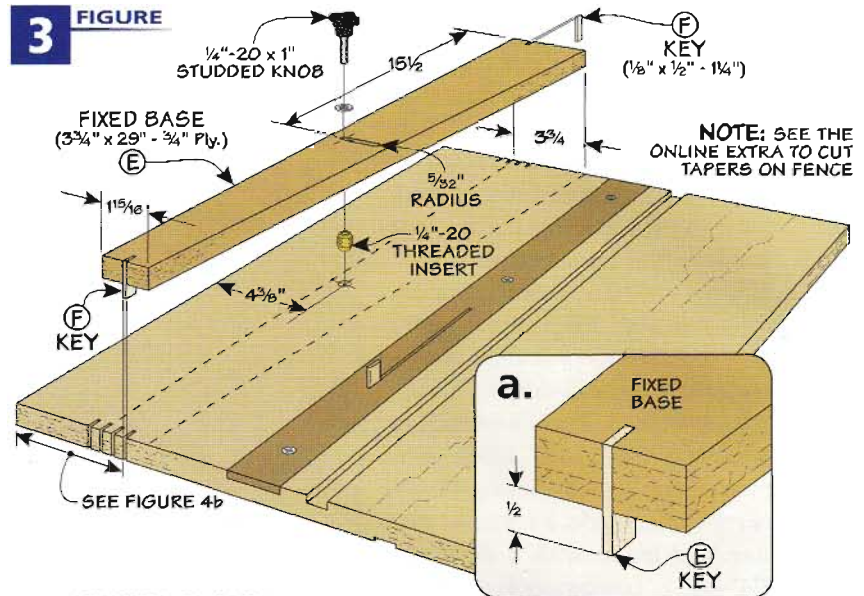

FENCE BLANK

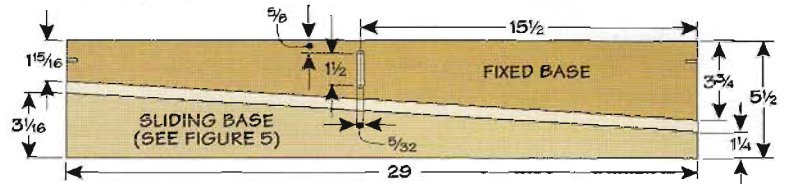

should be identical. This way, as you adjust the fence, it stays parallel to the blade. To make these cuts, I used a sled at the table saw. You can find out more about the sled in the Online Extras.

FIXED BASE. Take a look at Figure 3 to see how to make the tapered pieces from a single blank.

Now you need to take care of a couple of details on the fixed base. The first is a slot that's used to set the rough position of the fence. The slot acts as a guide to install a threaded insert in the platform.

The other detail is a notch cut in each end. These hold hardwood keys, as shown in Figure 3a. The keys slip into a matching series of notches in the platform.

CUTTING THE NOTCHES. The setup I used to cut all these notches is shown in Figure 4. Begin by cutting the first notch in the platform and the fixed base at the same time. The notches are cut with these pieces held on end.

Since this could be a little unsteady, you'll want to take a couple of steps to keep the pieces under control. Start by attaching the fixed base to the platform with a studded knob and a clamp. Figure 4a shows you where to position the fixed base for the cut. Then attach a tail auxiliary fence on the miter gauge to keep things stable.

To locate the notches accurately, I used the rip fence as an end stop.

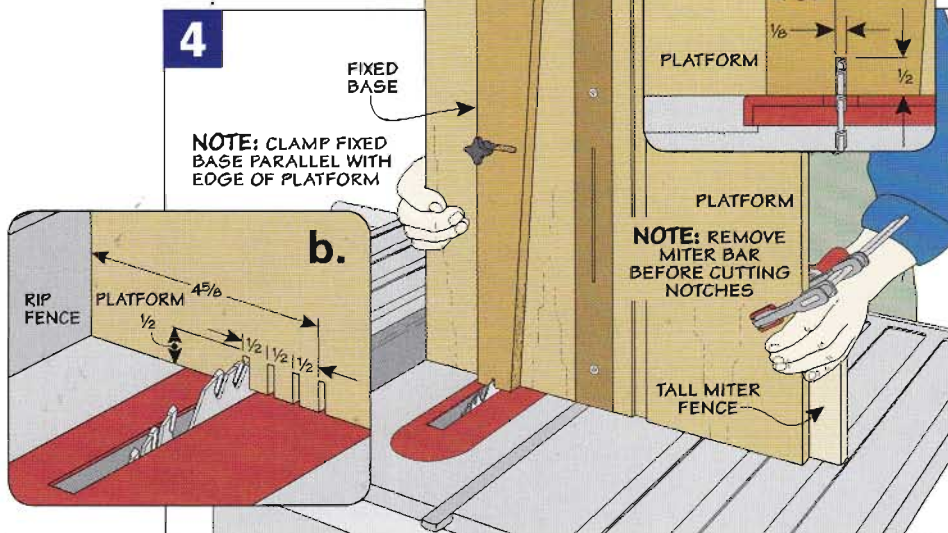

After making a notch at one end, flip the assembly end for end and cut a notch on the opposite end. Note: You'll need to move the clamp to the other end of the platform to make this cut.

To create the remaining notches in the platform, remove the fixed base and adjust the rip fence, as shown in Figure 4b.

HARDWOOD KEYS. Once you cut the notches in the fixed fence base, you can make and glue the hardwood keys in place, as illustrated in Figure 3a. Your aim is for the keys to fit snugly in the notches in the platform, but not be too difficult to insert or remove. I used some sandpaper to ease the edges and fine-tune the fit.

SLIDING ASSEMBLY. Now, you can turn your attention to the sliding L-shaped portion of the rip fence. The pieces for this assembly are shown in Figures 5 and 6.

The sliding base has a matching taper that slides along the fixed base. After using the tapering sled to cut the base to size, the only other thing you need to do is cut a groove near one edge.

As illustrated in Figure 5, the groove is sized to hold a length of aluminum T-track. This track is used to secure the sliding part of the fence once it's in position.

When cutting this groove, make sure to cut it parallel with

5 FIGURE

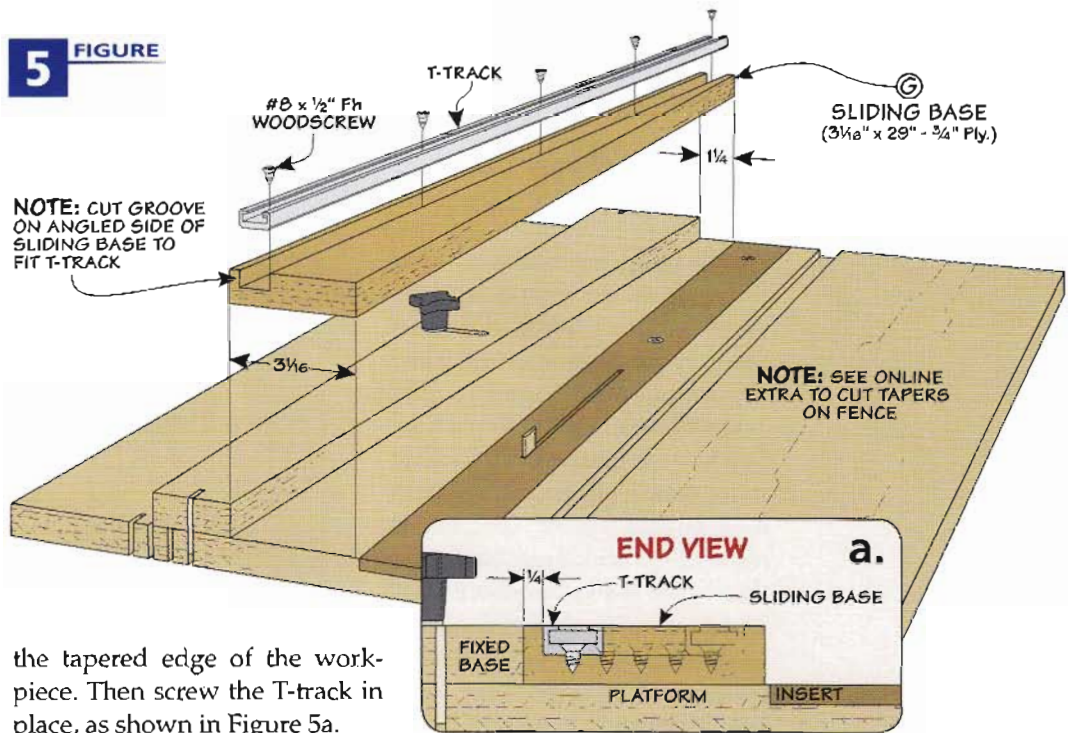

the tapered edge of the workpiece. Then screw the T-track in place, as shown in Figure 5a.

FENCE FACE. Attached to the sliding base is the upright portion of the rip fence. It's made up of two pieces. The main part is a plywood fence face. Attached to it is a replaceable hardboard insert.

The insert is identical to the blade inserts made earlier. And it's attached the same way — with screws and threaded inserts.

The plywood fence face also has a section of T-track mounted to it. This allows you to attach a featherboard or hold-down.

If you look at Figure 6a, you can see that the T-track is flush with the fence insert. So I had to

cut a shallow rabbet along the top edge of the fence face to accommodate the T-track. At this point, the upright portion of the fence can be glued to the sliding base. Just take care to keep the fence face square to the jig platform.

FEATHERBOARD. One useful accessory for the fence is a featherboard. My version is detailed in Figure 6 and featured as an Online Extra. It straddles the blade and holds the workpiece down both ahead of the blade and behind it.

GO
2
Online
Extras

For details on the taper sled and the featherboard, go to:
WoodsmithSpecials.com

6 FIGURE

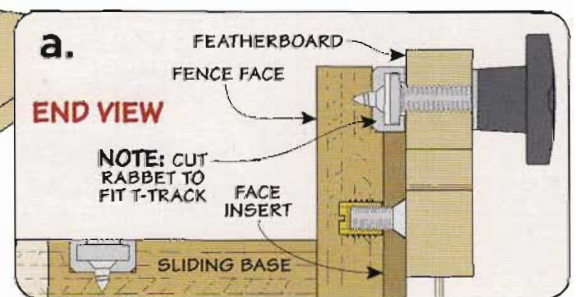
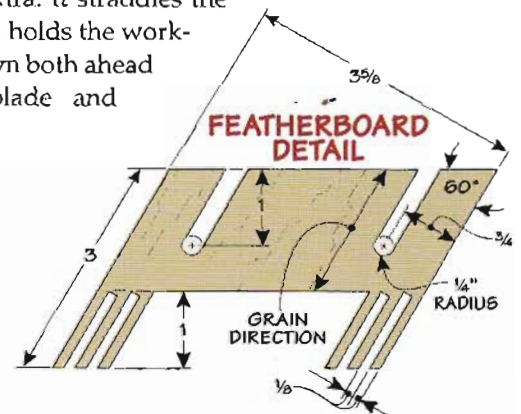
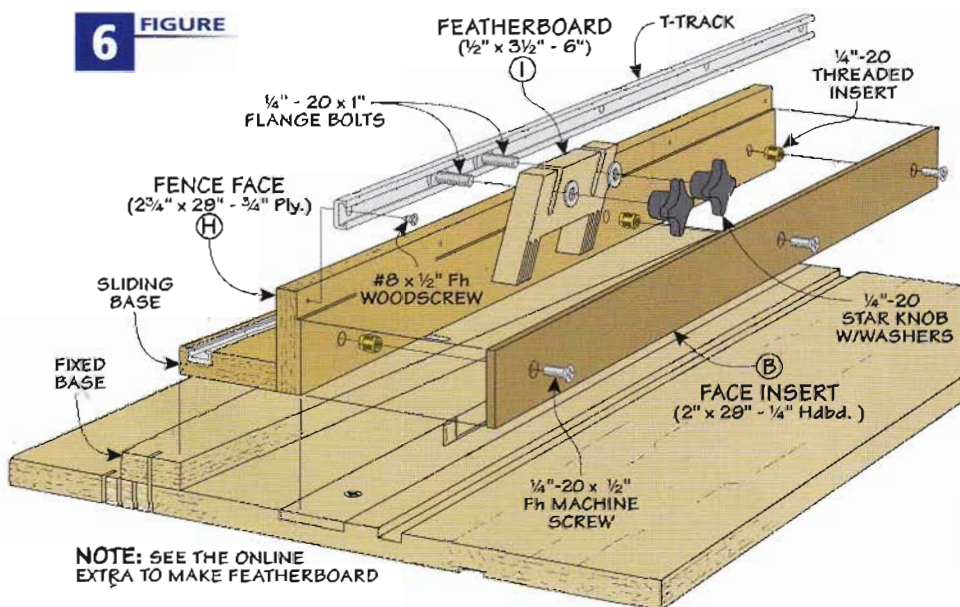

NOTE: SEE THE ONLINE EXTRA TO MAKE FEATHERBOARD

Lock Plate & Indicator

At this point, the two sections of the rip fence are essentially complete. All that's left is to connect them so the fence can be locked in position to make a cut.

LOCKING PLATE. Figure 7 shows how this is accomplished. It's nothing more than a plywood plate with a hardwood runner. The plate is attached to the fixed base, and the runner hooks into the T-track in the sliding portion of the fence, as shown in the photo at right. A flange bolt, washer, and knob hold everything in place.

The trick is that the runner in the plate sits in an angled groove. This allows it to mate with the tapered fence. You can use the same taper sled you used earlier to cut the groove.

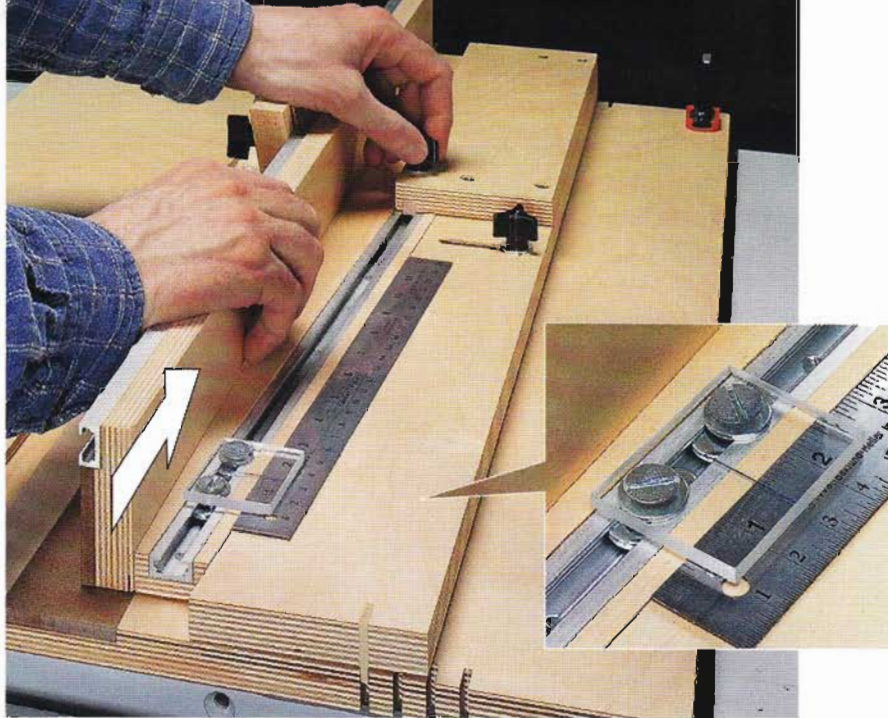

Adjusting the Fence. A ruler and indicator help you fine-tune the position of the sliding fence. Tightening the knob locks it in place.

When sizing the groove, the goal is to match the width to the slot in the top of the T-track (Figure 7a). Then you can cut a hardwood runner to fit and glue it in place. The last step is to drill a hole to accommodate the flange bolt, as in Figures 7 and 7a.

INDICATOR. You could put the jig to use as is, but I added one other feature — a hairline indicator. I use it as a gauge to adjust the position of the fence face. The tapered fence design gives you finer control for adjusting the fence. The ruler allows you to move the fence in precise, small increments. For example, a $\frac{1}{4}$ " of

movement on the ruler moves the fence $\frac{1}{64}$ " closer to or farther from the saw blade.

Making the indicator is a pretty simple task, as you can see in Figure 8. Attach a ruler to the fence base with screws or double-sided tape. Then cut a piece of acrylic to size and drill mounting holes.

To create the hairline, I used a utility knife and square to scratch a line on the back face. Filling in the line with a fine-tipped marker makes it stand out. Now, you can clamp the jig to the saw table and set up to rip thin strips. To handle crosscutting on the jig, take a look at the sled on the next page.

7 OVERVIEW

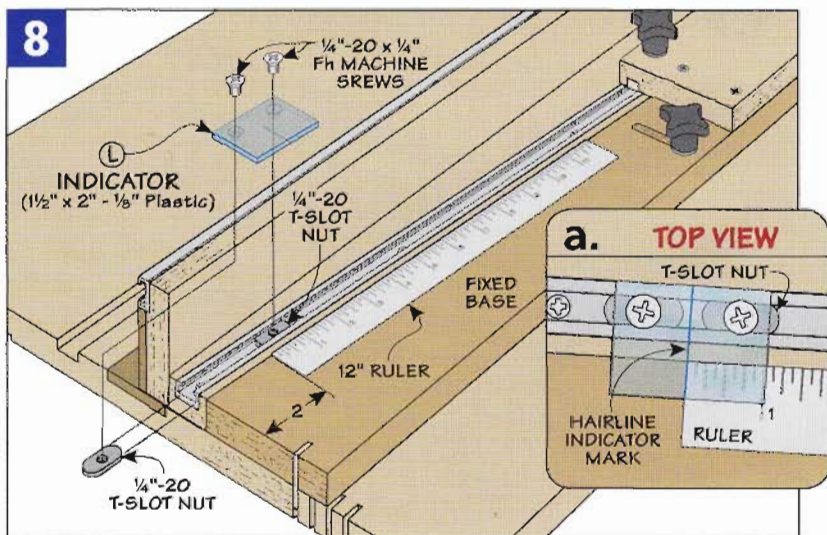
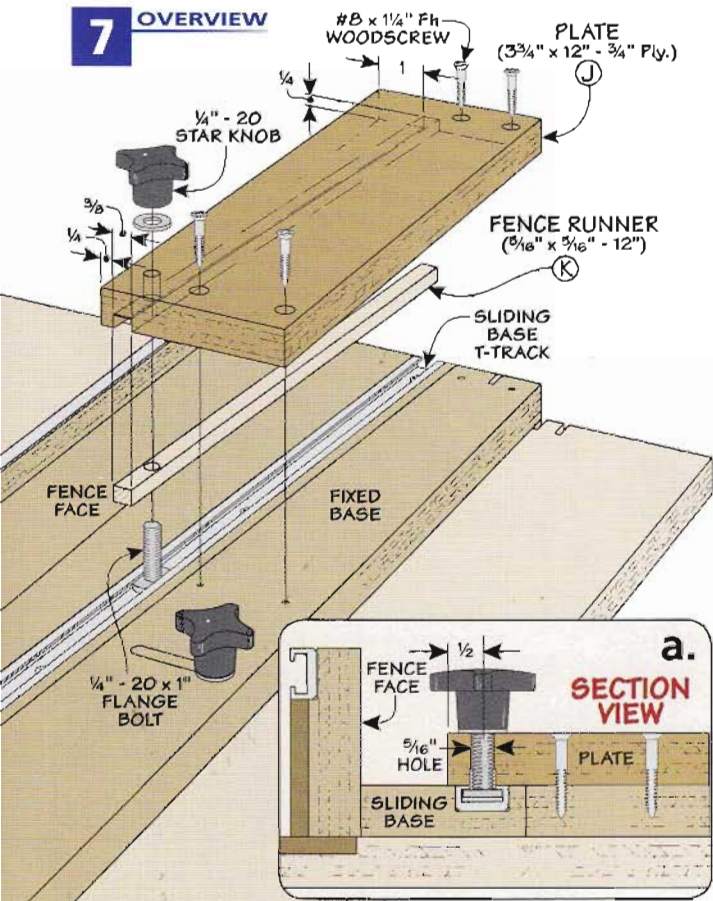

Small Parts Crosscut Sled

The platform and rip fence allow you to make precise, small-scale rip cuts. For crosscutting a small part, you need an alternative to a miter gauge. There are a couple of challenges. The first, of course, is cutting the piece accurately. The second is controlling the workpiece and the cutoff piece.

This crosscut sled lets you do both. It has a hardboard base and hardwood fence to keep a workpiece steady as it's cut. A runner on the bottom slides in a groove in the top of the platform.

The sled has a hold-down to prevent a piece from shifting or getting thrown by the blade. And it keeps your fingers away from the cut. Threaded inserts allow the hold-down to be positioned on either side of the blade.

Figure 9 provides the details for building the sled. I started

with a base then added the fence and a plywood blade guard.

The blade guard also houses three threaded inserts. Two are for the hold-down and the third accepts a tall plastic handle.

The critical part of making this sled comes when you attach the runner to the underside of the base. It needs to be perfectly square to the fence in order to make accurate crosscuts.

When that's done, you can set it in place on the platform and cut a kerf in the base. This kerf makes it a snap to line up a cut.

HOLD-DOWN. The final piece is the hold-down. It consists of three thin pieces of hardwood (Figure 9a). It's secured with a studded knob and washer.

Now the jig is complete. The results are new capabilities and versatility for your table saw.

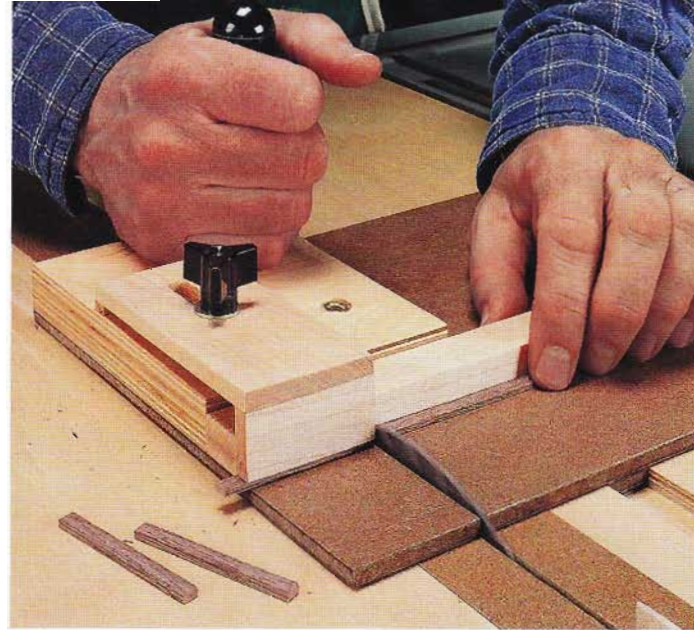

Crosscut Sled. The hold-down on this sled provides you with solid control over your workpiece, so you can make accurate crosscuts on small parts.

Materials & Hardware

CASE

A Platform (1)	$\frac{3}{4}$ " ply. - 20 x 29
B Inserts (2)	$\frac{1}{4}$ " hdbd. - 2 x 29
C Splitter (1)	$\frac{1}{8}$ " rgh. x 2 - $\frac{3}{4}$ "
D Miter Bar (1)	$\frac{1}{2}$ " x $\frac{3}{4}$ " - 29
E Fixed Base (1)	$\frac{3}{4}$ " ply. - 3 $\frac{3}{4}$ " x 29
F Keys (2)	$\frac{1}{8}$ " x $\frac{1}{2}$ " - 1 $\frac{1}{4}$ "
G Sliding Base (1)	$\frac{3}{4}$ " ply. - 3 $\frac{1}{16}$ " x 29
H Fence Face (1)	$\frac{3}{4}$ " ply. - 2 $\frac{3}{4}$ " x 29
I Featherboard (1)	$\frac{1}{2}$ " x 3 $\frac{1}{2}$ " - 6
J Plate (1)	$\frac{3}{4}$ " ply. - 3 $\frac{3}{4}$ " x 12
K Fence Runner (1)	$\frac{5}{16}$ " x $\frac{5}{16}$ " - 12
L Indicator (1)	$\frac{1}{8}$ " plastic - 1 $\frac{1}{2}$ " x 2

CROSSCUT SLED

M Sled Base (1)	$\frac{1}{4}$ " hdbd. - 6 x 12
N Fence (1)	$\frac{1}{2}$ " x $\frac{3}{4}$ " - 12
O Blade Guard (1)	$\frac{3}{4}$ " ply. - 4 x 5
P Runner (1)	$\frac{1}{4}$ " hdbd. - $\frac{3}{4}$ " x 6
Q Hold-Down (1)	$\frac{1}{4}$ " x 1 $\frac{5}{16}$ " - 4
R Hold-Down Back (1)	$\frac{1}{8}$ " x $\frac{1}{4}$ " - 1 $\frac{5}{16}$ "
S Hold-Down Front (1)	$\frac{1}{4}$ " x $\frac{7}{8}$ " - 1 $\frac{5}{16}$ "

- (2) 36" T-Tracks
- (5) $\frac{1}{4}$ "-20 x 1" Flange Bolts
- (2) $\frac{1}{4}$ "-20 T-Slot Nuts
- (10) $\frac{1}{4}$ "-20 Threaded Inserts
- (5) $\frac{1}{4}$ "-20 Star Knobs
- (2) $\frac{1}{4}$ "-20 x 1" Studded Knobs
- (1) $\frac{1}{4}$ "-20 x 1" Studded Handle
- (1) 12" Ruler
- (1) 1 $\frac{1}{2}$ " x 2" - $\frac{1}{8}$ " Plastic for Indicator
- (2) $\frac{1}{4}$ "-20 x $\frac{1}{4}$ " Fh Machine Screws
- (6) $\frac{1}{4}$ "-20 x $\frac{1}{2}$ " Fh Machine Screws
- (9) $\frac{1}{4}$ " Washers
- (10) #8 x $\frac{1}{2}$ " Fh Woodscrews
- (4) #8 x 1 $\frac{1}{4}$ " Fh Woodscrews

9 FIGURE

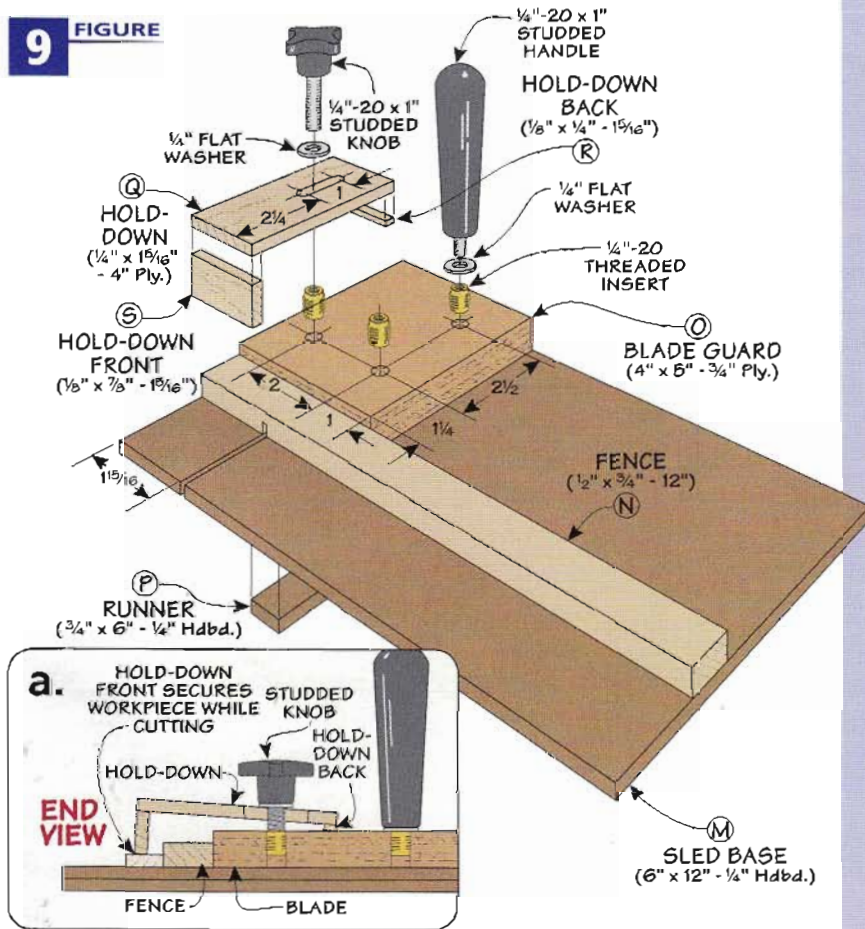



BIESEMEYER

40 35 30 25 20 15 10 5
DELTA CONTRACTOR'S SAW



Upgrades & Add-Ons

With just a few do-it-yourself upgrades, you can increase the potential of your table saw. Find out how to transform it into a multi-purpose workstation without sacrificing shop space.

TABLE SAW WORKCENTER 74

SPACE-SAVING IDEAS 86

ALL-IN-ONE PROJECT STATION 88



Table Saw Workcenter

Take a contractor's saw, a router, a couple of sheets of MDF, and a handful of hardware, and turn it into this complete workcenter.

For me, the most satisfying shop projects are the ones I know I'll put to use day in and day out. And if there was ever a project that filled this bill, it's the table saw workcenter you see here.

This project has a long list of features. The workcenter is designed around a standard contractor's saw. And it will accommodate just about any saw on the market. (Ours is a *Delta*, with a heavy-duty *Biesemeyer* rip fence).

As you can see in the photo, the table of the saw is surrounded by a huge worksurface that makes crosscutting or ripping workpieces (large or small) a breeze.

Off to the right side of the workcenter, you'll find a large, stable router table with all the extras — a drop-in insert, a miter gauge slot, and an easy-to-adjust fence. And basically the entire lower part of the workcenter is dedicated to valuable storage.

Now you might be thinking that a project with this many highlights is probably difficult, time-consuming, and expensive to build. Not so. A combination of modular casework, simple but sturdy joinery, and inexpensive materials keeps both the work and the cost to a minimum.

And believe it or not, you can make a good thing even better by adding the outfeed stand on page 84 to the workcenter.

Exploded View Details

OVERALL DIMENSIONS:
37¹/₄"D x 64¹/₄"W x 34³/₄"H

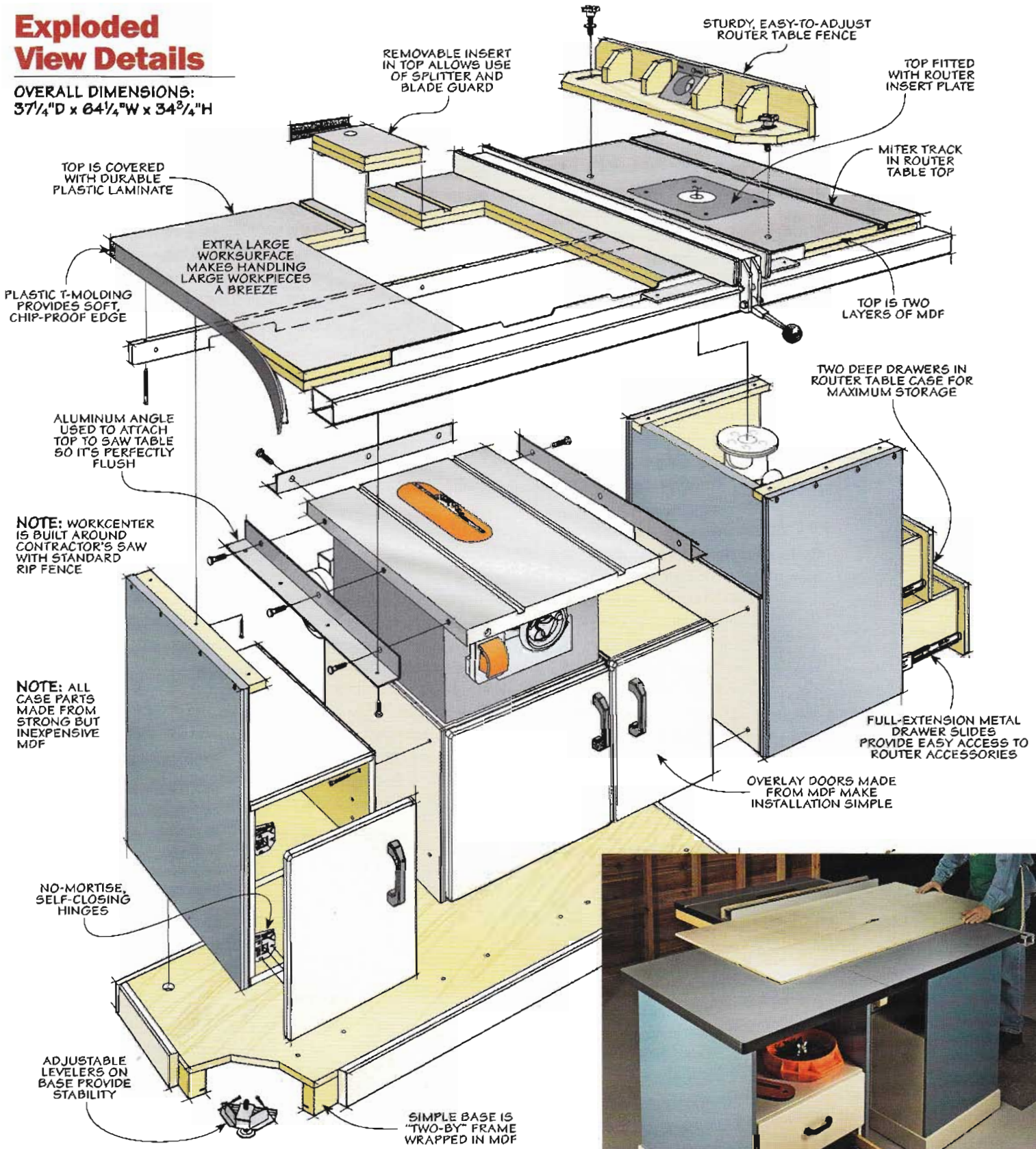

Optional Outfeed Stand. Easier cuts and more storage are a couple of the benefits you'll get from this outfeed stand. You'll find the details on page 84.

NOTE: MODULAR CASE DESIGN MAKES ASSEMBLY GO QUICKLY

Building the Cabinet

As you can see here, your first job is to build the main cabinet that supports the table saw and router table. Take a look at the drawing at right and you'll see that the cabinet consists of a stack of four short MDF cases fastened to a long, continuous base. You'll find that this simple, modular assembly makes the work go fast and easy without sacrificing a bit of strength. The best plan is to tackle the cases first, then build the sturdy base to fit them.

GETTING STARTED. Other than size and a few interior details, the four cases are built identically. You'll find the biggest differences in the case that supports the table saw, so I saved it for last.

EASY JOINERY. My goal was to build the cases solidly, but also to keep the joinery as straightforward as possible. So take a quick look at Figures 2 and 3 below, and you'll see how the two storage cases and the router table case are put together. Basically, once the parts are cut to size, all you'll have to do to complete the joinery is

1 FIGURE

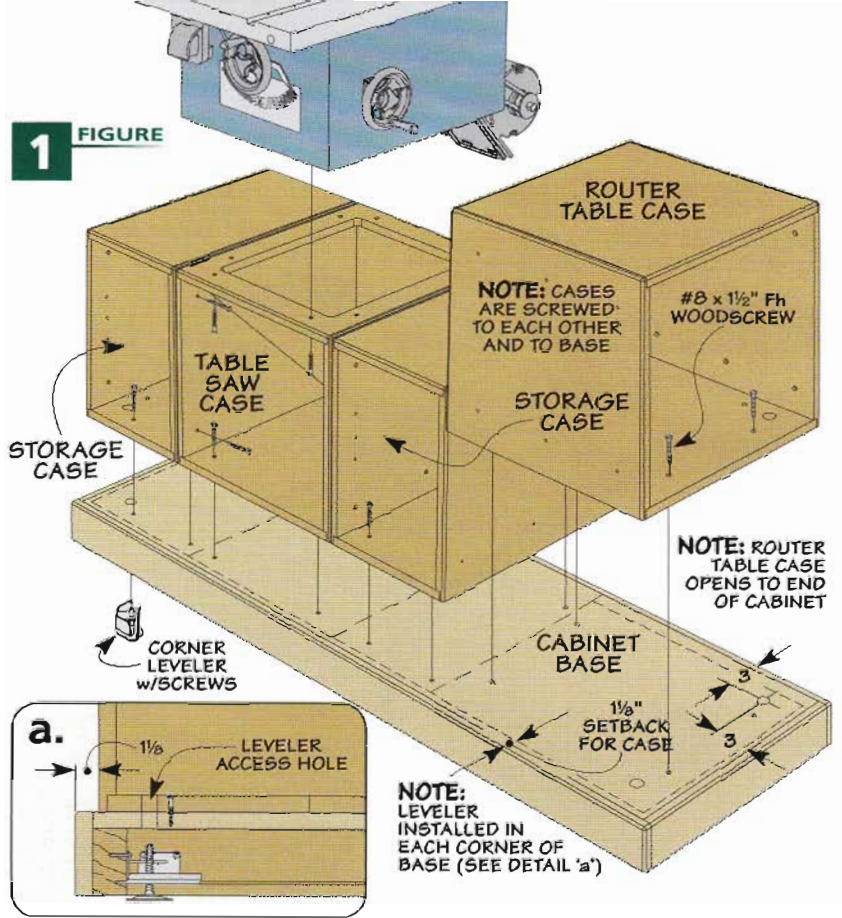

install a dado blade on the table saw and start cutting rabbets.

Figure 2a shows how the case sides are rabbeted to hold the top and bottom. And then if you look at Figure 3a, you'll see that the sides, top, and bottom are all rabbeted to capture the back panel.

A FEW DETAILS. Before gluing the cases together, there are a couple

of interior details to take care of. You'll need to drill shelf pin holes in the two storage cases for the shelves you'll add later. Notice that these three cases have a series of countersunk screw holes on the sides and bottoms (Figures 2 and 3). When the time comes, these holes will be used to fasten the cases together and to the base.

2 FIGURE

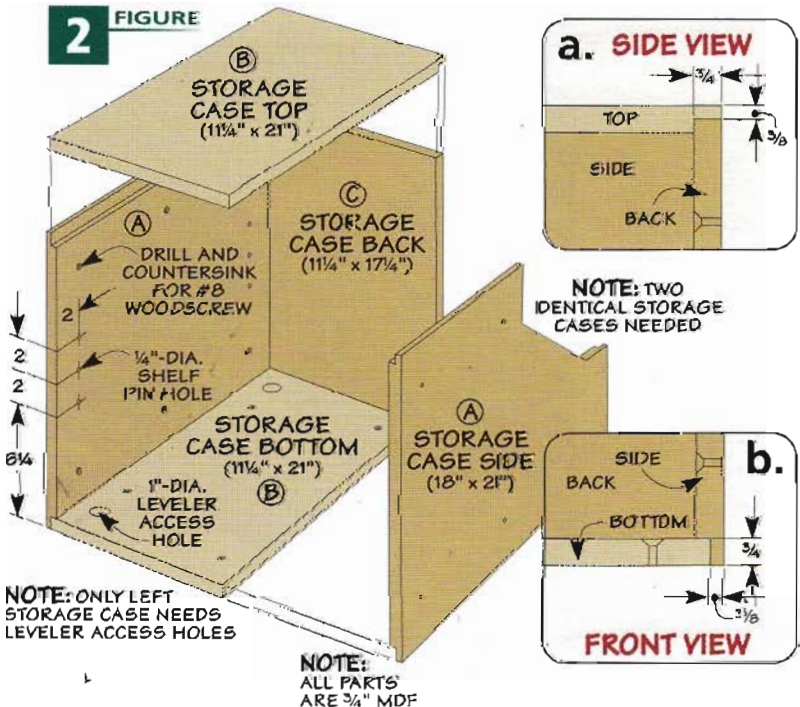

3 FIGURE

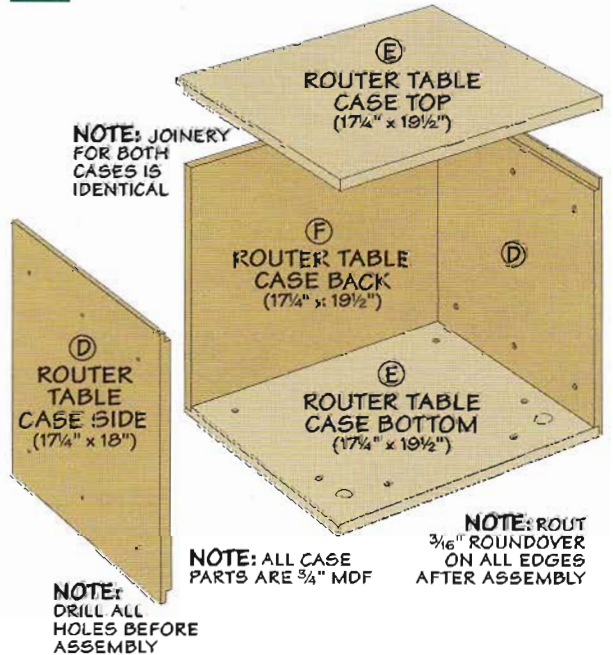

GO
2
Online Extras

For a tip on providing clearance for the saw motor, as well as materials, supplies, and cutting diagrams, go to:

WoodsmithSpecials.com

There's one last thing. To be certain the workcenter was good and stable when set in place, I planned to add levelers to the corners of the base later. This means you'll need access to the levelers to adjust them. For this purpose, I drilled access holes in the router table case and the left storage case (and later the base).

Now, the cases are ready for glue and clamps. And once the assembly is complete, all the outside edges of the cases need to be rounded over.

TABLE SAW CASE. I had one requirement for the table saw case that made building it a bit more involved — dust collection. Figure 4 shows how it works. As you can see, the top of the case has a large cutout. I did this by drilling holes at the corners and removing the waste with a jig saw.

DIVIDER. Below the cutout, an angled divider funnels the dust to the back of the case. It's held in place by a pair of angled cleats.

It works best to add the divider after the case is assembled. First, cut the parts to size, and screw the cleats and the divider together. Then you can slide the assembly into the case from the front and fasten it in place from above.

Finally, rather than cut a dust port directly into the back panel, I opted for a large cutout covered with a separate dust port panel. This will give you better access to the dust chamber when needed.

THE BASE. Once all four cases are complete, you can build the base that connects them. Like the cases, it's pretty basic, but there's one point I should mention up front. The base is sized to hold the four cases and the end panels that support the top, along with the overlay doors and drawers. When everything is in place, the goal is to have an even $\frac{3}{8}$ " reveal all the way around.

You start the base by building a sturdy frame from "ripped down" two-by stock (Figure 5).

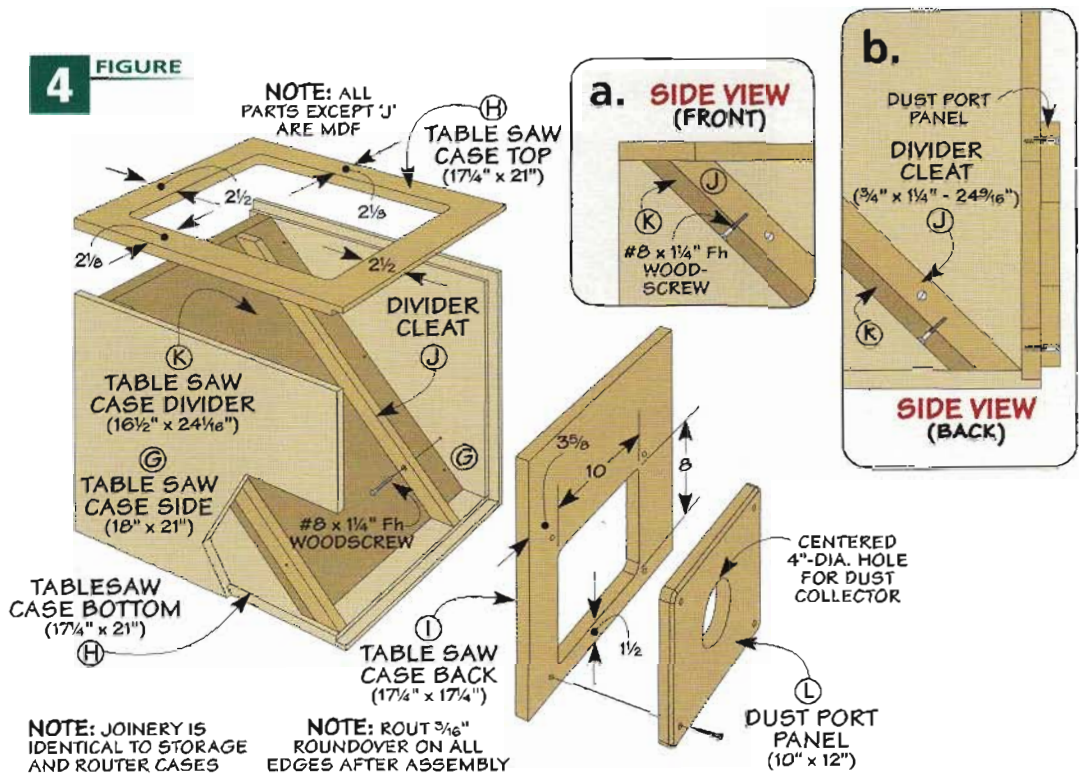

The only detail you'll need to worry about is a saw kerf running around the inside perimeter. This gives extra support to the levelers you'll add later (Figure 5a). I relied on woodscrews to assemble the frame.

Once the frame is assembled, you can wrap it with an MDF skirt and top. The skirt pieces are butted at the corners, and the top is cut to fit inside the skirt. With this done, I drilled an adjustment hole in each corner and then installed the levelers.

Finally, I routed a roundover on the top edges and the corners.

PUT IT ALL TOGETHER. Now you're ready to screw all the cases and the base into one assembly. Here, you just want to make sure everything is aligned. First, I set the cases in place on the base and fastened them together. The four cases should be flush across the front (this will be the side of the router table case). Now, when you fasten the cases to the base, leave an even $\frac{1}{8}$ " setback on each end and across the front.

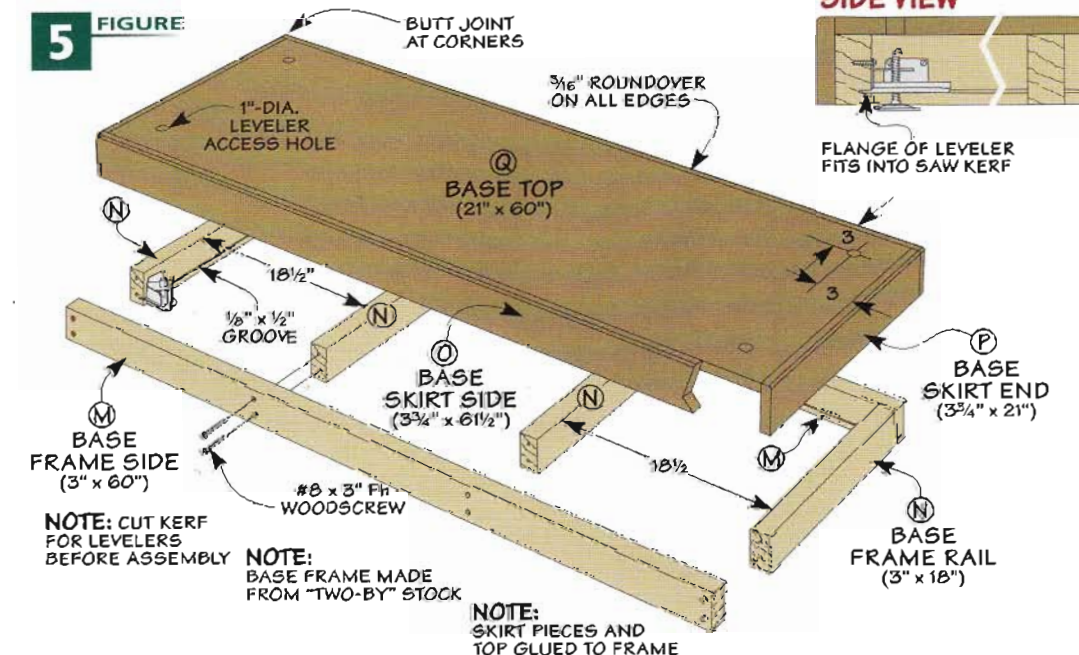



Easy Installation. These no-mortise hinges make installing the doors a quick and easy job.

At this point, the cases and the base are joined into one assembly, but one of the major features of the workcenter — its generous storage — still needs more work. The three front cases simply need doors and shelves. But I had other ideas for the router table case. Here, easy access to my ever-growing collection of router bits and accessories was my number one goal. A couple of deep drawers were the answer.

SIMPLE DOORS. I took on the easier challenge of making the overlay

doors first. As you can see in Figure 6, I certainly didn't get fancy here. I started by cutting panels of MDF to overlap the openings in the cases by $\frac{1}{2}$ " on all sides. And then after rounding the sharp corners, I routed a roundover on the outside edges. All that's left is to add the hardware.

MOUNTING THE DOORS. To install the doors, I turned to self-closing, no-mortise hinges (left margin). They look a little intimidating, but actually, I found that they were pretty easy to install.

There are a couple of tips I can share with you. First, these hinges are designed to be used on both inset and overlay doors. For the overlay doors, you want to attach the hinge plate with the long arm to the case (Figure 6b). This will give you the right "swing."

Second, the hinges have slotted screw holes for horizontal adjustment, but not much in the way of vertical adjustment. So to help me get the vertical position correct, I drew corresponding centerlines for the hinge plate on both the door and the case. You can simply center the middle screw hole of the hinge plate on this line.

DETAILS. A few more details and you can move on to the drawers for the router table case. You won't need catches on the doors, but you will need pulls. I ordered durable, hard plastic pulls for this job. They simply screw to the face of the door. And finally, I cut a couple of MDF shelves to size for the two storage cases (Figure 6a).

THE DRAWERS. The drawers for the router table case are likewise, no frills. They're just sturdy boxes with false, overlay fronts (Figure 7). Full-extension slides give you easy access to everything inside.

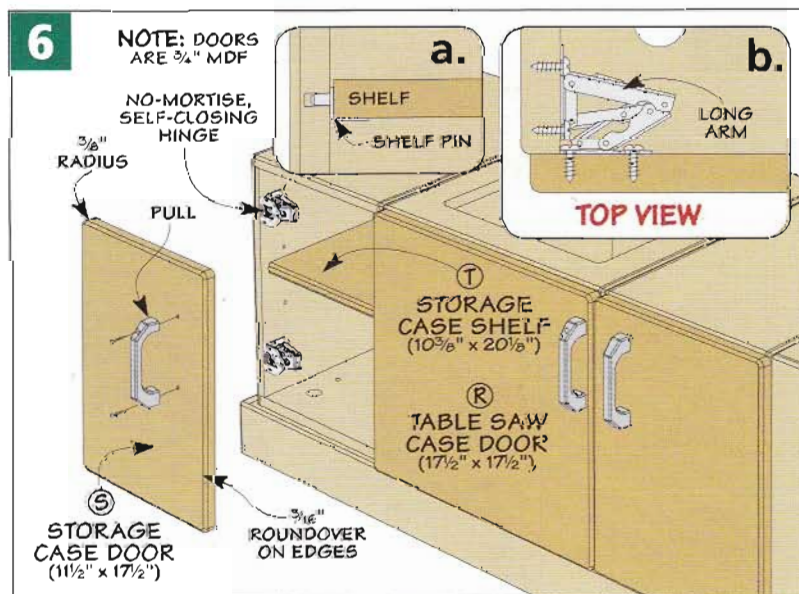

THE DETAILS. A quick overview will be all you'll need to build the drawers. The sides, fronts, and backs are cut from 1/2" Baltic birch plywood. The plan calls for metal slides, so allow 1/2" clearance between the case sides and both sides of the drawers (Figure 7c).

THE JOINERY. The joinery on the boxes is a basic tongue and dado. You'll start by cutting a 1/4"-wide dado in both ends of the sides. Then cut a matching tongue on each end of the front and back to create a rigid joint (Figure 7a). A groove in all four pieces holds a 1/4" plywood bottom (Figure 7b).

FRONTS. Once the drawer boxes were assembled, I cut the false fronts to size and gave them the same treatment as the doors — rounded corners and a rolover on the outside edges (Figure 7d).

Before adding the fronts, you'll want to install and adjust the slides. Then, use double-sided tape to locate the fronts on the boxes, and drill the screw holes used to attach them. Finally, remove the tape, refasten the fronts, add the pulls, and you're done.

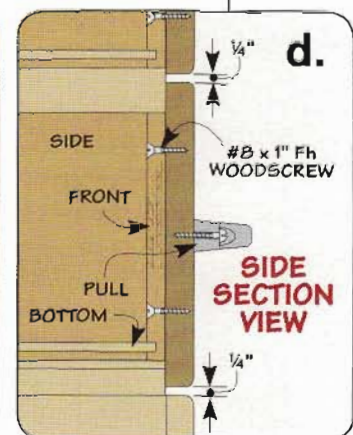
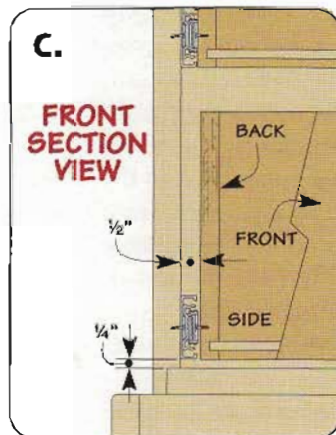
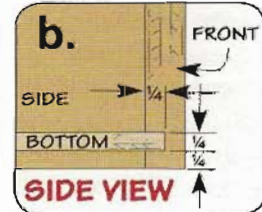
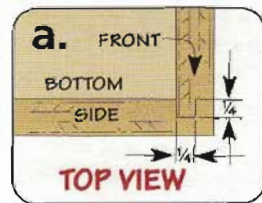
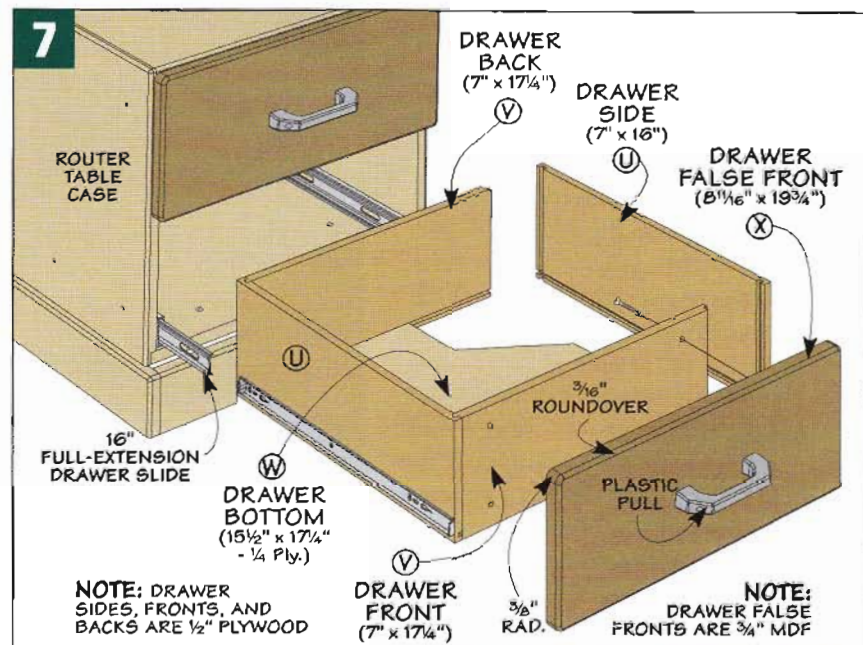

Materials & Hardware

- | | | | | |
|-----------------------------|-----------------------------|--|-----------------------------|-------------------------------------|
| A Stor. Case Sides (4) | 3/4" MDF - 18 x 21 | V Dwr. Fronts/Backs (4) | 1/2" ply. - 7 x 17 1/4 | • (1) Router Insert Plate |
| B Stor. Case Tops/Btms. (4) | 3/4" MDF - 11 1/4 x 21 | W Dwr. Bottoms (2) | 1/4" ply. - 15 1/2 x 17 1/4 | • (5) 4 3/4" - Long Handles |
| C Stor. Case Backs (2) | 3/4" MDF - 11 1/4 x 17 1/4 | X Dwr. False Fronts (2) | 3/4" MDF - 8 1/16 x 19 3/4 | • (6) 5/16" T-Nuts |
| D R.T. Case Sides (2) | 3/4" MDF - 18 x 17 1/4 | Y Left Top Section (1) | 1 1/2" MDF - 20 1/2 x 37 | • (1) 1 1/2" x 15' T-Molding |
| E R.T. Case Top/Btm. (2) | 3/4" MDF - 17 1/4 x 19 1/2 | Z Right Top Section (1) | 1 1/2" MDF - 37 1/2 x 37 | • (2) 5/16" x 2" Studed Knobs |
| F R.T. Case Back (1) | 3/4" MDF - 17 1/4 x 19 1/2 | AA Left Side Panel (1) | 3/4" MDF - 21 3/4 x 29 3/2 | • (2) 5/16" Flat Washers |
| G T.S. Case Sides (2) | 3/4" MDF - 18 x 21 | BB Left Side Panel Cleat (1) | 3/4 x 1 1/2 - 21 3/8 | • (1) Dust Collection Hood |
| H T.S. Case Top/Btm. (2) | 3/4" MDF - 17 1/4 x 21 | CC R.T. Side Panels (2) | 3/4" MDF - 18 x 29 1/2 | • (1) Miter Track |
| I T.S. Case Back (1) | 3/4" MDF - 17 1/4 x 17 1/4 | DD R.T. Side Panel Cleats (2) | 3/4 x 1 1/2 - 17 5/8 | • (8) Shelf Support Pins |
| J T.S. Case Cleats (2) | 3/4 x 1 1/4 - 24 9/16 | EE R.T. Case Partition (1) | 1/4" MDF - 20 1/4 x 11 1/2 | • (4) #6 x 3/4" Fh Woodscrews |
| K T.S. Case Divider (1) | 3/4" MDF - 16 1/2 x 24 3/16 | FF Splitter Insert (1) | 1 1/2" MDF - 6 x 10 | • (24) #8 x 3" Fh Woodscrews |
| L Dust Port Panel (1) | 3/4" MDF - 10 x 12 | GG Splitter Insert Cleat (1) | 3/4 x 3/4 - 6 | • (2) #10 x 3/4" Sheet Metal Screws |
| M Base Frame Sides (2) | 1 1/2 x 3 - 60 | HH Top Cleat (1) | 3/4 x 2 - 63 | • (53) #8 x 1 1/2" Fh Woodscrews |
| N Base Frame Rails (4) | 1 1/2 x 3 - 18 | II Fence Base (1) | 3/4 x 6 - 30 | • (10) #8 x 1 1/4" Rh Woodscrews |
| O Base Skirt Sides (2) | 3/4" MDF - 3 3/4 x 61 1/2 | JJ Fence Face (1) | 3/4 x 4 - 30 | • (46) #8 x 1 1/2" Fh Woodscrews |
| P Base Skirt Ends (2) | 3/4" MDF - 3 3/4 x 21 | KK Fence Braces (4) | 3/4 x 3 - 3 | • (6) 5/16" x 1" Lag Screws |
| Q Base Top (1) | 3/4" MDF - 21 x 60 | • (4) Corner Levelers | | • (8) #8 x 3/4" Sheet Metal Screws |
| R T.S. Case Door (1) | 3/4" MDF - 17 1/2 x 17 1/2 | • (2 pr.) 16" Full-Extension Drawer Slides | | • (4) #6 x 5/8" Fh Woodscrews |
| S Stor. Case Doors (2) | 3/4" MDF - 11 1/2 x 17 1/2 | • (3 prs.) Spring Hinges w/Screws | | • (8) #8 x 1" Fh Woodscrews |
| T Stor. Case Shelves (2) | 3/4" MDF - 10 3/8 x 20 1/8 | • (2) 1 1/2 x 1 1/2" - 4" Alum. Angle (1/8" Thick) | | • (1) Router Table Dust Port |
| U Dwr. Sides (4) | 1/2" ply. - 7 x 16 | • (2) 48" x 72" Plastic Laminate (Face/Backer) | | |

Making the Top



The table saw and router table top is where the work will get done when I put this workcenter to use in my shop. So I was looking forward to starting on this part of the project.

A QUICK LOOK. First, I'll give you a general overview. Take a look at Figure 8 below, and you'll see that the top consists of two main sections. Each is made up of a double-thickness of MDF with plastic laminate on both sides.

Both sections wrap around the back of the saw table. And a gap between them provides a space for the splitter and blade guard. It can be filled with a "pop out" insert, like you see in Figure 10. Finally, the top is attached to the saw table by way of aluminum angle bolted to the saw table (Figure 8a). I'll cover the rest of the details along the way.

A NEW BASE. Before I began making the table saw and router table top, I took my saw off its stand and moved it to its new home on

the workcenter cabinet. This way, when the top is ready to install, everything will be in place.

GET STARTED. I started building the top by gluing up an oversized, two-layer, MDF panel for each top section. Then before applying the laminate, you'll want to cut the sections to final size and shape. The less opportunity to chip the laminate, the better.

You really have two jobs here. First, cutting each section to overall size, then making the L-shaped cutouts that allow the sections to wrap around the saw table.

I was able to do some of this work at my table saw. But the

large size of the right section and the notches presented a couple of problems. The solution is to first rough cut the pieces to size and then use a router with a straight bit installed and a straightedge to trim them accurately.

PLASTIC LAMINATE. Now you can apply the plastic laminate and trim it flush. You'll want to be sure to apply a backer laminate to the underside to keep the top "balanced" and flat. But don't worry about the edges, they get a different treatment later.

MITER GAUGE SLOTS. You'll notice in Figure 8, that the miter gauge slots extend into the top. Since this is just for clearance, I routed oversized slots and didn't worry about perfect alignment.

CLEARANCE. Just a couple more things and the top sections will be ready to install. In order for the top to fit over the aluminum angle and snug to the saw table, you'll need to rout a deep, narrow rabbet around the L-shaped cutouts, like you see in Figures 8a and 8b. You'll also need to counterbore for the heads of the bolts, but this step can wait until after the angle is installed.

SIDE PANELS. Before installing the new top, the cabinet below needs one more addition. In Figure 9, you'll see how three MDF side panels are screwed to the cabinet to help support the top — one on the left end and one on either side of the router table case.

The panels rest on the cabinet base. A hardwood cleat at the top

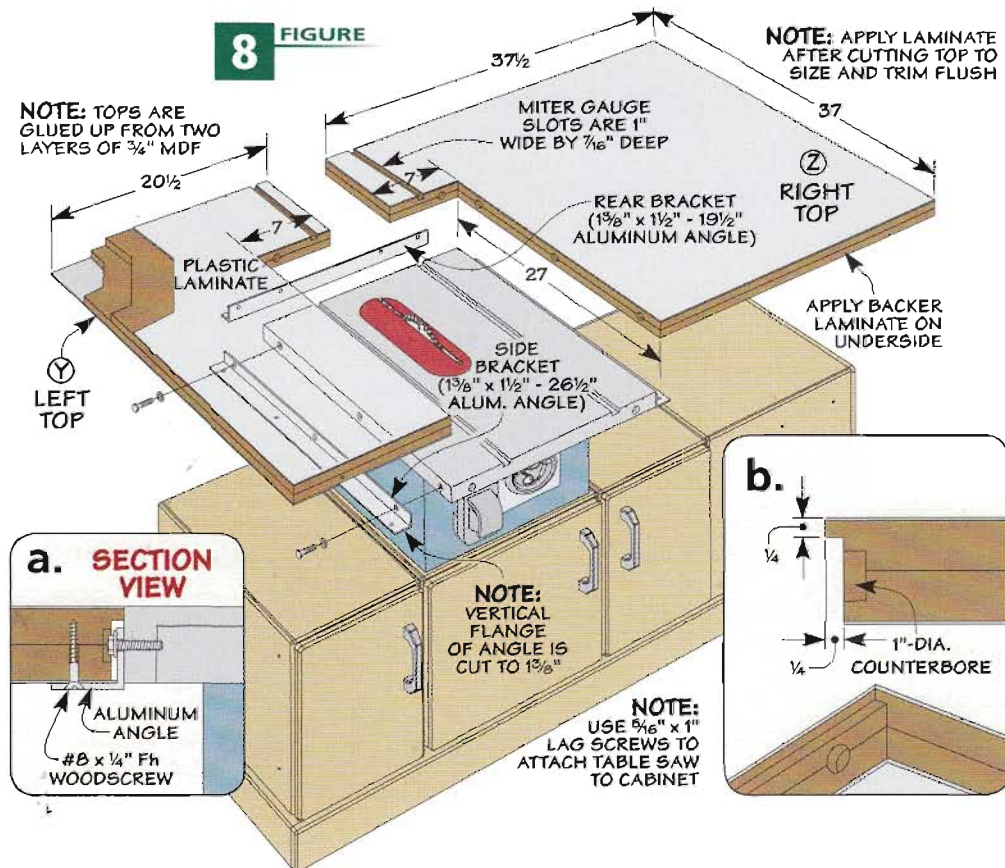

of each panel is used to fasten the top down. There's also an upper partition at the back of the router table case, which adds additional support and helps control the dust from the router.

It's important that the panels support the top level with the saw table. Figure 9a illustrates how to find the height of the panels. Just measure from the top of the base to the top of the saw table and then subtract the thickness of the new top.

NEW TOP. Once the side panels are in place, you can take the extension wings and fence off the saw and switch to the new top.

The aluminum angle used to attach the top is fastened to the saw table using the bolts and threaded holes that held the extension wings. To allow easy adjustment of the height of the angle, I drilled the bolt holes oversized. Figure 9b shows how to adjust the angle for a flush fit of the top. Once the aluminum angle is attached and adjusted, the two top sections can be set in place and screwed down.

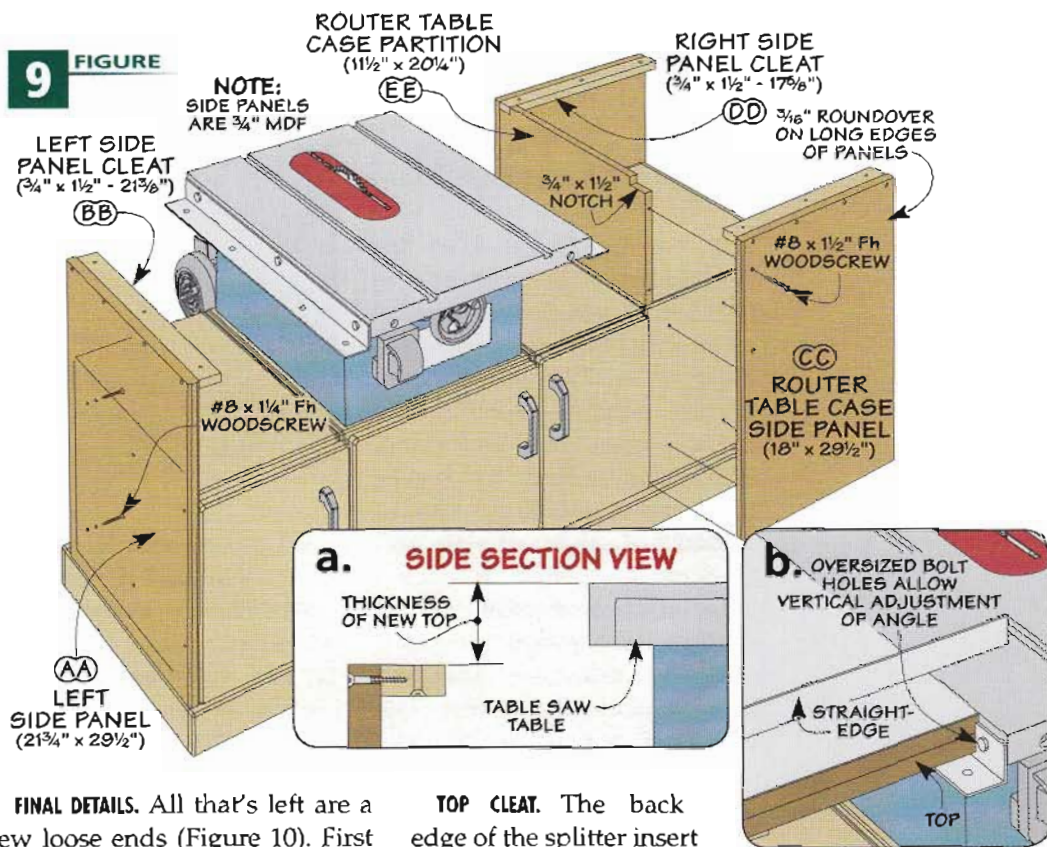

FINAL DETAILS. All that's left are a few loose ends (Figure 10). First comes the splitter insert that fills the gap at the back of the top, as shown in the right margin photo. It's sized to fit snugly in its pocket and has laminate on both sides. I added a finger hole to remove it and a cleat to keep it in place.

TOP CLEAT. The back edge of the splitter insert rests on a long cleat that's screwed to the underside of the top, like you see in Figure 10b. This cleat's main purpose is to connect the top sections and keep them flat and true.

You'll notice that the cleat has a good-size notch cut into it. This provides clearance for the motor when the blade is tilted to 45°.

T-MOLDING. The last item is the top edging. For this, I turned to easy-to-install and chip-proof, plastic T-molding. But before starting on this, decide whether you plan on building the outfeed stand on page 84. If so, hold off and install all the T-molding at once.

INSTALLATION. The first thing to do is round all the corners of the top so the molding will bend around them. The T-molding is held in place by a flange that fits a slot in the edges of the top (Figure 10a). So routing this narrow, centered slot is the next job. You can mark the ends of the rip fence rail and stop the slots there.

Then installing the T-molding on the top is as easy as pressing or lightly tapping it into place.

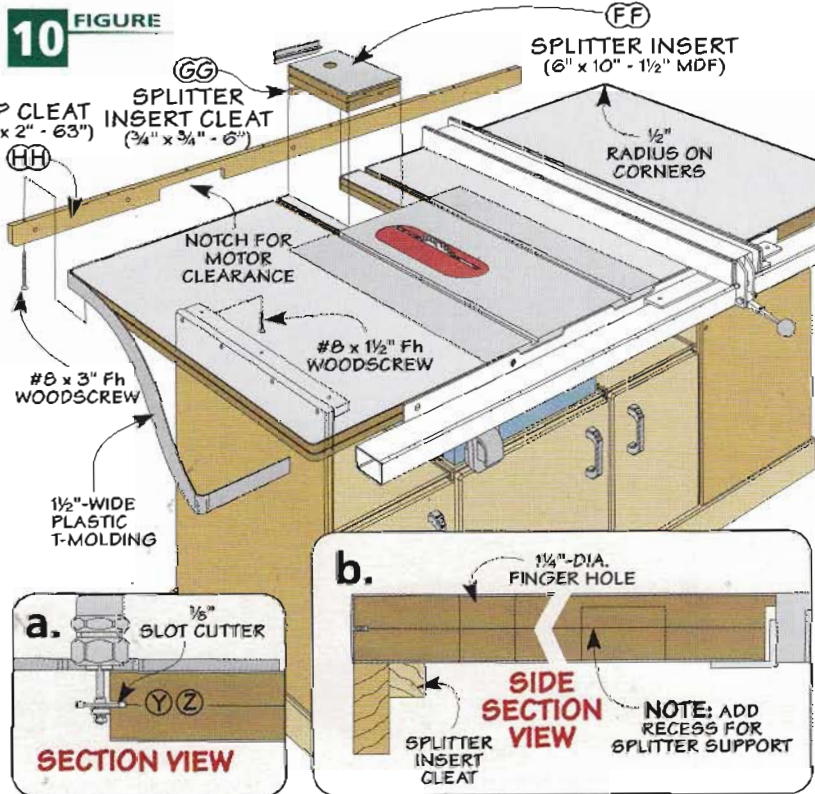

Splitter Insert. Removal of the "pop out" insert makes way for installation of the splitter and the blade guard.

Completing the Router Table

With the top in place on the workcenter, your table saw is back in business. So now you can set your sights on completing the router table. This comes down to three things — installing the phenolic insert plate in the top, adding a miter track, and finally, building and installing the fence.

INSERT PLATE. An insert plate isn't an extra, it's a must. It saves a huge amount of effort on bit changes and generally makes using the router table easier. So I added a heavy-duty insert plate with "pop out" collars. You can see the pop out collars and how to fit the insert in Figure 11 and the photo on the next page.

MITER TRACK. After installing the insert, you need to add the aluminum miter track. To do this, I simply routed an appropriately

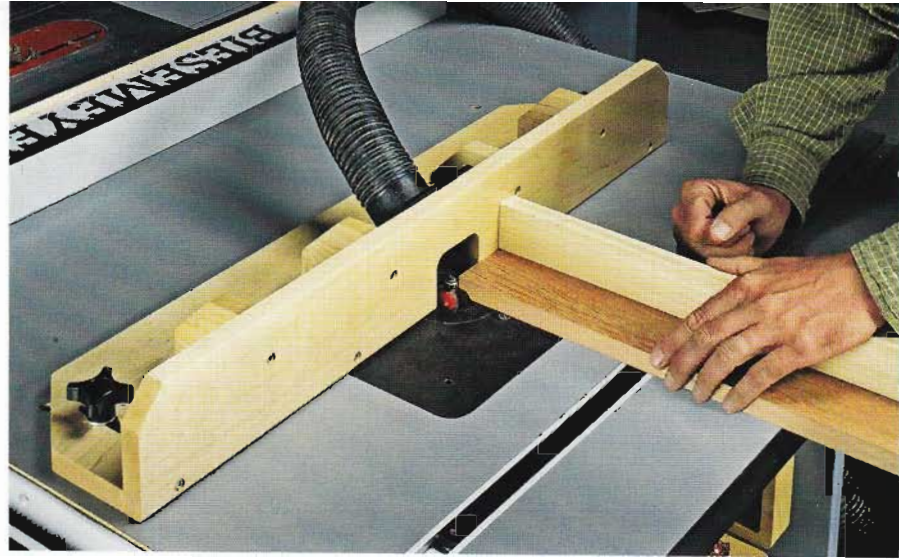

sized groove and then screwed the track in place (Figure 11).

THE FENCE. Now all that's left is to add a fence. Take a look at Figure 12, and you'll see the practical answer for how to do this. The fence I built is simply a hardwood base and face screwed together in an "L" shape. Four braces keep it square and large cutouts provide plenty of bit clearance.

Smooth, easy adjustment is important, and this job is handled by a pair of slots in the

fence base and studded knobs that screw into T-nuts installed in the top (Figures 12a and 12b). For a wider adjustment range, I installed three sets of T-nuts, as shown in Figures 11 and 11a. As you can see, the T-nuts are countersunk on the underside of the top. You'll want to do this after drilling the shank holes.

That's it. Your new workcenter is ready. But before putting it to the test, be sure to check out the outfeed stand on page 84.

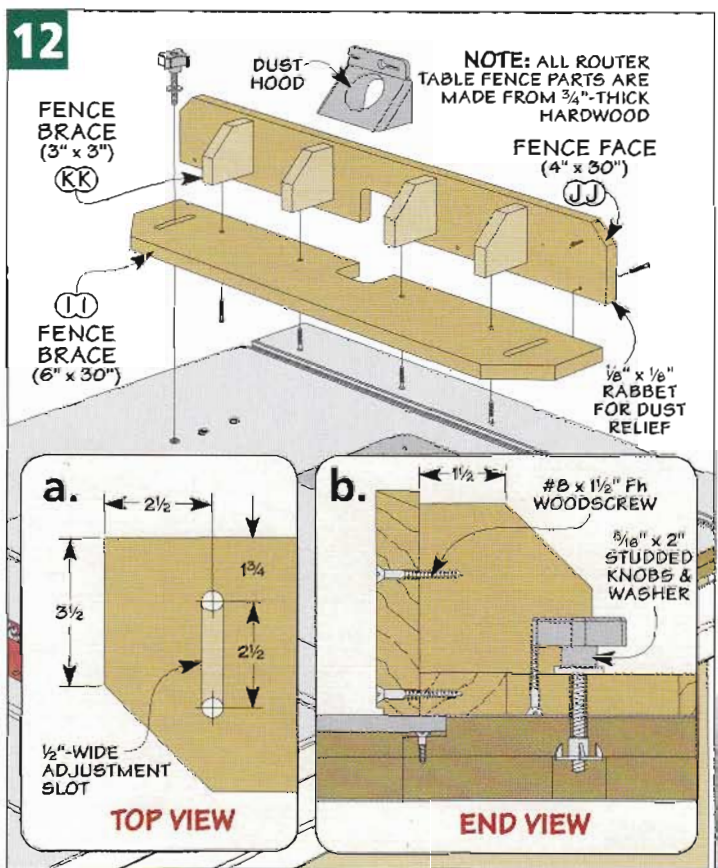
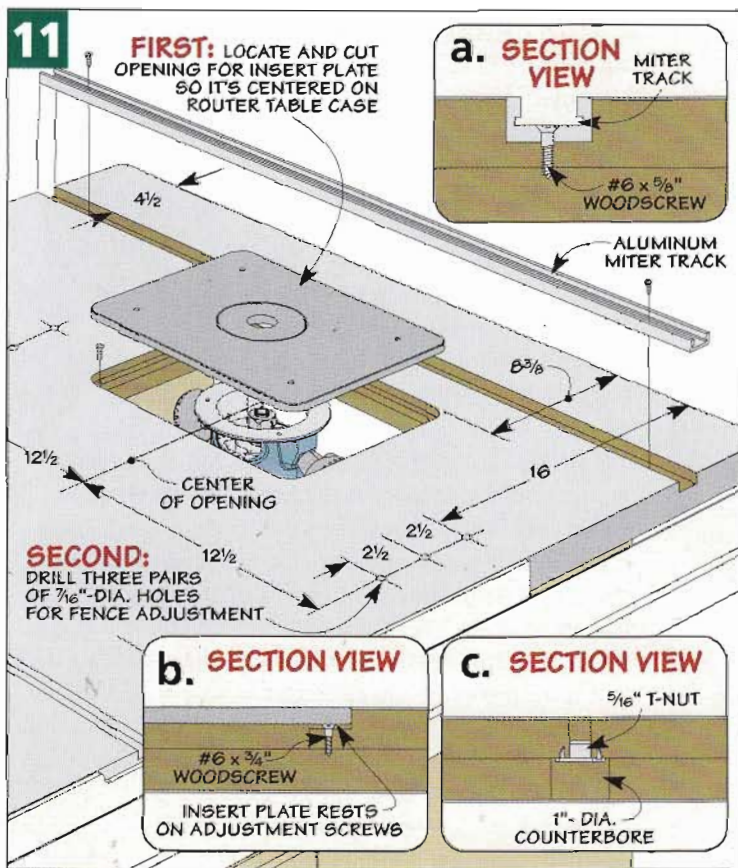

Step-by-Step: Insert Plate

An insert plate should fit snugly in the router table top and be perfectly flush with the surface. The drawings below show how I accomplished this.

Basically, you'll need to make an accurately sized, rabbeted cutout in the top of the workcenter (photo at right). The rabbeted pocket that holds the insert is $\frac{1}{8}$ " deeper than the thickness of the insert. Then a screw installed in each corner allows you to adjust the height of the insert (Figure 12a on page 82). Note that the insert plate is centered over the case below.

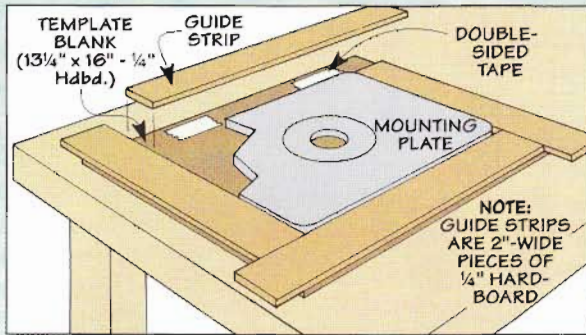

1. Start the Template. To install the insert, you need to make a hardboard template. First, place the insert on the template blank and wrap it with guide strips.

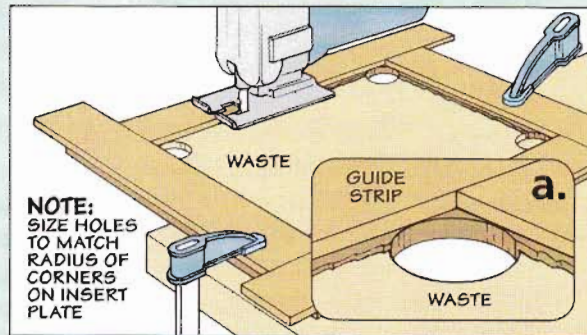

2. Remove the Waste. Drill a hole in each corner that matches the corner radius of the insert. Then remove the waste — cutting to the inside of the strips.

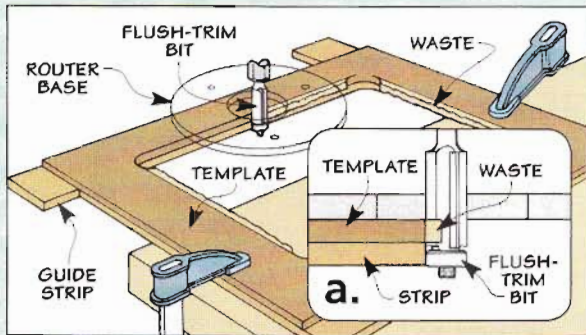

3. Flush Trim. To complete the template, smooth the rough cuts between the holes with a router and flush-trim bit. Notice I flipped the assembly over.

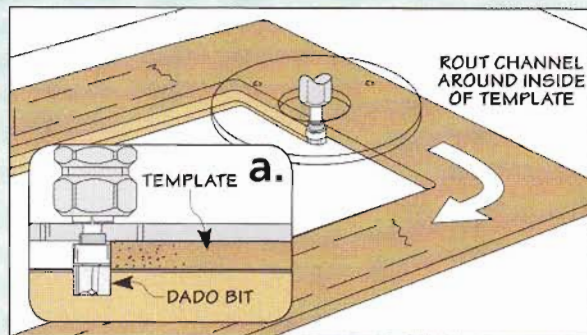

4. Start the Cutout. Next, with the template held in place on the top by double-sided tape, I routed a narrow channel around the inside of the template.

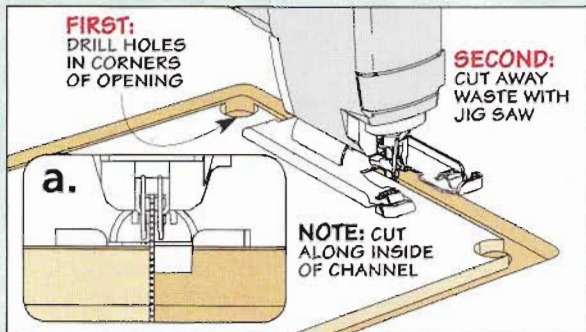

5. Complete the Cutout. After drilling starter holes in the corners, complete the cutout with a jig saw. Just cut along the inside edge of the channel.

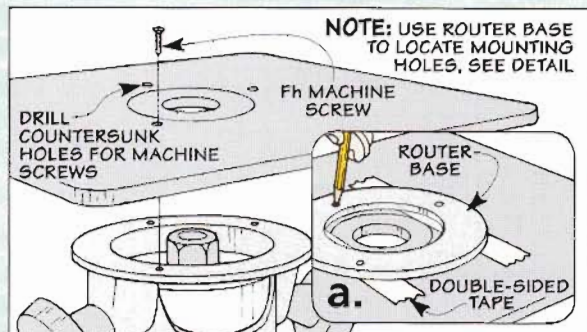

6. Mount the Router. Finally, you can mount the router to the insert using the router base plate as a template to locate the screw holes.



Dado Bit.

I used a short dado bit with a top-mounted bearing to rout the pocket for the insert plate.

Optional Outfeed Stand

The large top of the workcenter is a big plus. But when cutting sheet stock or ripping long boards, you also want steady outfeed support. And that's where the outfeed stand, shown in the photo at right, comes in.

OUTFEED PLUS. Although offering safe, stable outfeed support for ripping and cutting large panels is its main duty, the outfeed stand also gives you three different types of storage. Below the top is a deep "pass-through" storage area where the tools you use often can be kept close at hand. The case that forms the lower part of the stand is divided down the middle. On the left, you'll find open shelving, while on the right side of the case I added a couple of drawers. And a bonus is that the top can do double-duty as an extra worksurface.

BUILDING THE STAND. There is one other important benefit here. Just like the main cabinet, the outfeed stand is designed to go together quickly and easily. In general, the construction of this cabinet and



its top is identical to the main cabinet you've already seen. The only things that are different are the size and a few details. So, all you should need is a quick overview of the construction.

THE CASE. You'll start by building a simple case out of MDF, as shown in Figure 13. The joinery is identical to that used on the cases for the main cabinet. Rabbits in the sides capture the top and

bottom (Figure 13a). But there is one new twist here. As mentioned before, to make the case a bit more practical, I added a vertical divider. An MDF panel dadoed into all four case parts handles this job (Figure 13b).

As you can see in the drawing, the divider is offset toward the open, shelf side of the case. This makes room for deeper drawers and keeps the shelves narrower and more accessible.

That's all for the joinery. But before the case is assembled, you have some holes to drill. The case sides need shelf pin holes, the sides and bottom have countersunk assembly holes, and finally, the bottom gets leveler access holes.

THE BASE. Building the base is basically a repeat of the base for the main cabinet — a frame made from "two-by" stock wrapped in MDF (Figure 14). And don't forget that the base needs to be sized to hold a couple of side panels and the overlay drawer fronts,

13 FIGURE

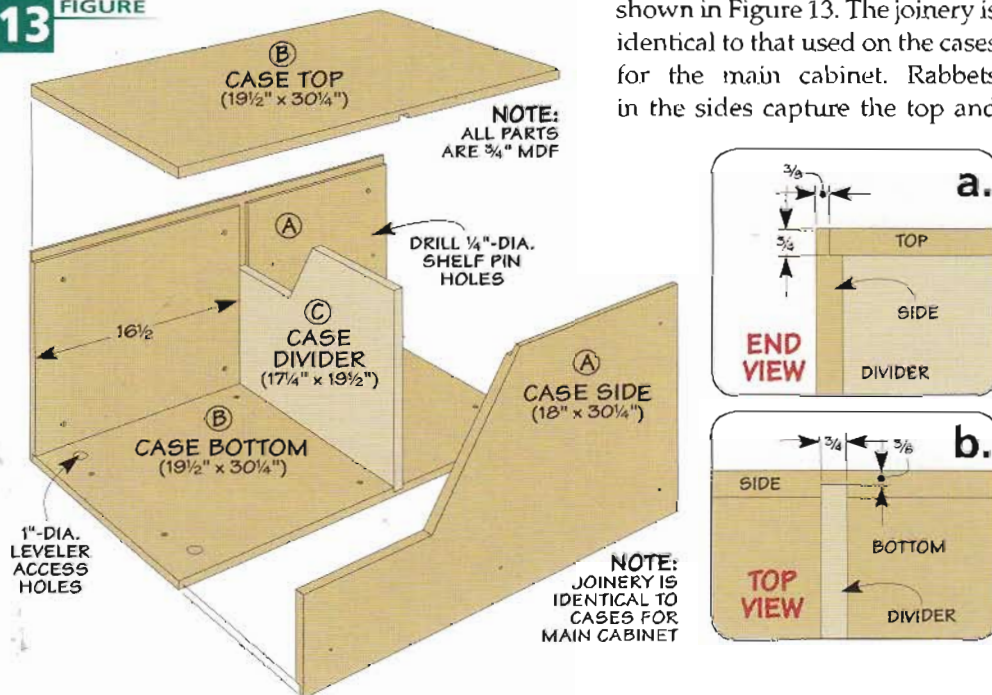

as well as the case. The levelers on the base make it easy to align the top of the outfeed stand with the top of the workcenter.

SIDE PANELS. Once the case and base are assembled, you can add the side panels, as shown in Figure 14. Again, the details are all the same. You can cut the panels to the same height as the panels for the main cabinet. After rounding over the long edges and attaching the cleats, the panels are simply screwed to the case sides.

THE TOP. Now the cabinet needs a top. Figure 14 provides the details. It's basically just a smaller, simpler version of the top for the workcenter: a double layer of MDF with laminate on both sides and T-molding on the edges.

One long edge of the top butts against the back edge of the main top. So these two corners are left square and there's no T-molding on this edge. But you will need a cleat along this edge to mate with the cleat across the back of the main top. These two cleats tie the two tops together, as shown in Figure 14a. Hex bolts, washers, and nuts create a snug joint.

NEAR THE END. All you have left to build are a pair of drawers for the deep side of the cabinet and a shelf for the shallow side.

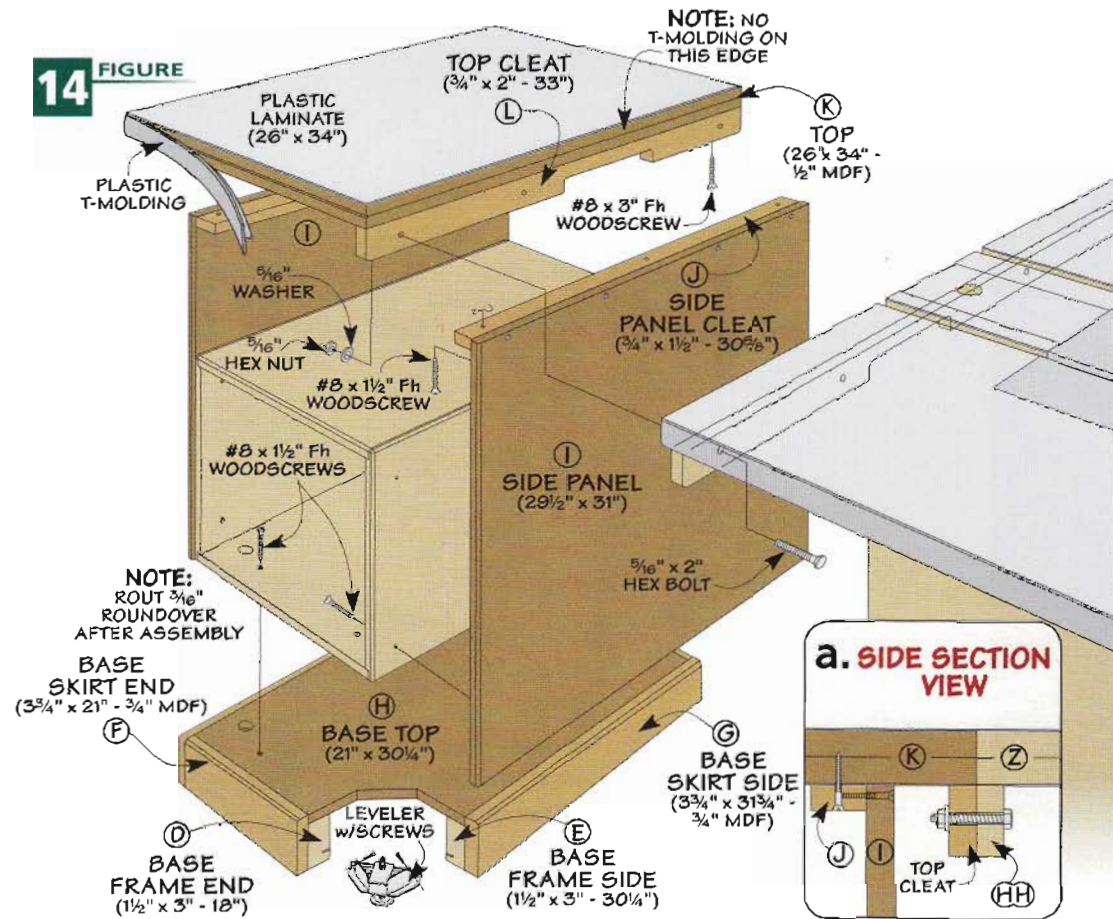

The drawers, shown in Figures 15 and 15a below, should look pretty familiar. In fact, they're identical to the drawers built for the router table case. You'll find all the details you need on page 78.

The last step is to move the stand into position, level it up, and bolt it in place (Figure 14a). Then it can start earning its keep.

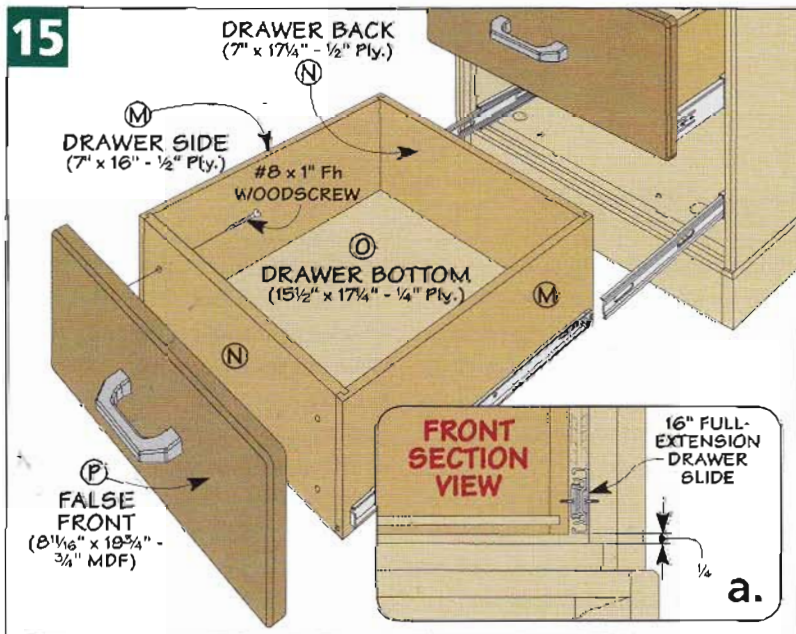

Materials & Hardware

A	Case Sides (2)	3/4" MDF - 18 x 30 1/4"
B	Case Top/Bottom (2)	3/4" MDF - 19 1/2" x 30 1/4"
C	Case Divider (1)	3/4" MDF - 17 1/4" x 19 1/2"
D	Base Frame Ends (2)	1 1/2" x 3" - 18"
E	Base Frame Sides (2)	1 1/2" x 3" - 30 1/4"
F	Base Skirt Ends (2)	3/4" MDF - 3 3/4" x 21"
G	Base Skirt Sides (2)	3/4" MDF - 3 3/4" x 31 3/4"
H	Base Top (1)	3/4" MDF - 21" x 30 1/4"
I	Side Panels (2)	3/4" MDF - 29 1/2" x 31"
J	Side Panel Cleats (2)	3/4" x 1 1/2" - 30 5/8"
K	Top (1)	1 1/2" MDF - 26" x 34"
L	Top Cleat (1)	3/4" x 2" - 33"
M	Dwr. Sides (4)	1/2" ply. - 7" x 16"
N	Dwr. Fronts/Backs (4)	1/2" ply. - 7" x 17 1/4"
O	Dwr. Bottoms (2)	1/4" ply. - 15 1/2" x 17 1/4"
P	Dwr. False Fronts (2)	3/4" MDF - 8 1 5/16" x 19 3/4"
Q	Case Shelf (1)	3/4" MDF - 12 3/4" x 18 5/8"

- (4) Corner Levelers
- (2) 4 3/4" - Long Handles
- (2 pr.) 16" Full-Extension Drawer Slides w/Screws
- (4) Shelf Support Pins
- (2) 48" x 48" Plastic Laminate (Face/Backer)
- (1) 1 1/2" x 10" T-Molding
- (12) #8 x 3" Fh Woodscrews
- (20) #8 x 1 1/2" Fh Woodscrews
- (12) #8 x 1 1/4" Fh Woodscrews
- (3) 5/16" x 2" Hex Bolts w/Nuts & Washers
- (8) #8 x 1" Fh Woodscrews

Space-Saving Ideas

Four quick and easy-to-build solutions to maximize the storage space around your table saw.

No matter what kind of wood-working you do, chances are that the table saw is the heart of your shop. So it's only natural that most woodworkers give their table saw the best location in the shop — usually right in the center, with plenty of room on all sides for handling long boards and sheet goods.

Although your table saw may deserve more space than any of your other power tools, there's no reason why that area can't be organized for maximum benefit. Here are four ideas to help you get the most out of the space your saw occupies. None of them takes more than an hour or two of time to build, but you're sure to appreciate the extra space they'll provide for years to come.



NOTE: LIFTING END OF SAW BRINGS WHEELS INTO CONTACT WITH FLOOR

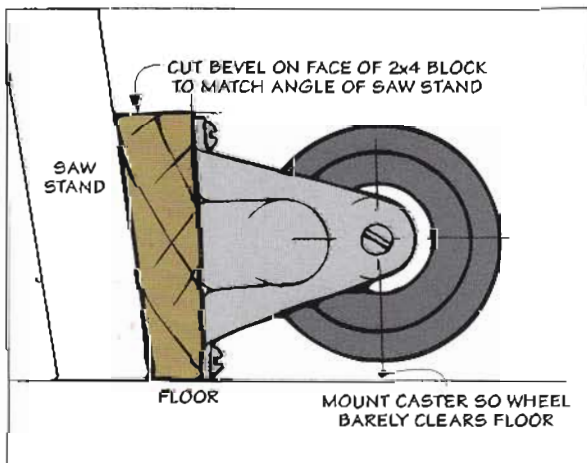

Making it Mobile

It's no secret that table saws eat up a lot of real estate in a shop. But there's an easy way to reclaim some of that space — make your saw mobile. This allows you to roll the saw out of the way when you're not using it.

Now there are plenty of after-market mobile bases available. But you can get the same results by simply adding a pair of casters to your existing table saw stand.

Mount the casters to a block of wood and bolt it to the stand (drawing above). The trick is to position the casters just above the floor (drawing at left). Then you just have to slightly lift up the end of the saw to bring the casters in contact with the floor so you can roll it around like a wheelbarrow. The best part is that when you set the saw back down, it rests solidly on the floor.

Bolt-On Pegboard

It doesn't take long to accumulate a number of accessories for your table saw — like blades, insert plates, and arbor wrenches to name a few. Instead of taking up space in a tool cabinet or drawer, add a simple storage rack to the side of your table saw stand, as shown in the drawing at right.

The rack is nothing more than a piece of $\frac{1}{4}$ " pegboard that's cut to match the profile of the side of your stand. After drilling holes in the metal stand, just bolt the pegboard in place and use pegboard hooks to hang up the items that you want to keep close at hand.

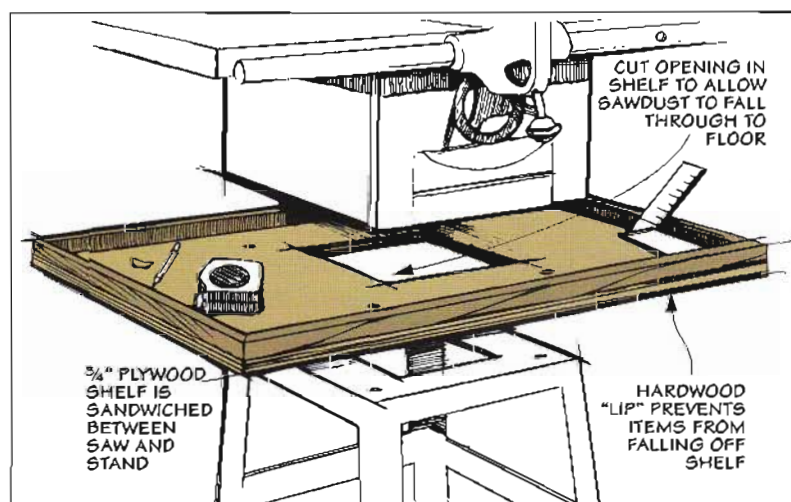
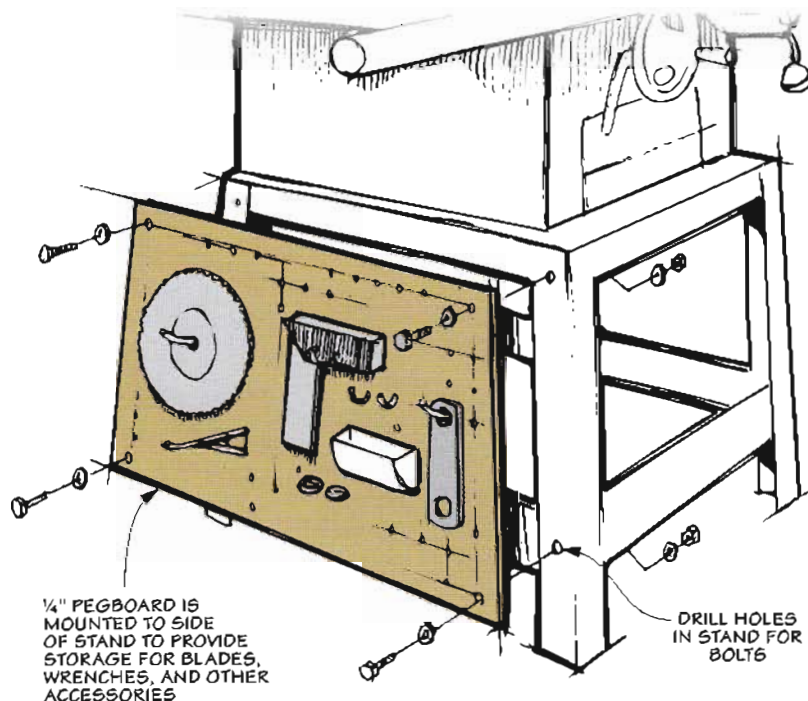

Tool Shelf

When I'm working at the table saw, I usually have a number of items that I'm constantly using to lay out and mark my workpieces — a square, tape measure or rule, and a pencil. If you set these items on top of the saw, they can get in the way or accidentally fall off onto the floor because of the vibrations of the saw. An easy solution is to add a tool shelf to your saw like the one you see at left.

The shelf is just a piece of $\frac{3}{4}$ " plywood that's sandwiched in between the saw and the stand. A hardwood lip on all four edges keeps items from falling off. And an opening cut in the center of the shelf allows sawdust to fall through to the floor.

Table Saw Worksurface

In a small shop, worksurfaces are often in short supply. So it seems only natural for the top of your saw to end up working as an assembly table or finishing area when it's not being used for cutting wood. But there are a couple of drawbacks to this.

For one thing, workpieces tend to fall into the miter gauge slots and the opening in the insert plate when you're working on top of your saw. And you also run the risk of scratching or damaging the surface of your table saw by working directly on it.

The solution is a simple one. All you need to do is make a

cover that slips over the top of your table saw and doubles as a worksurface, just like you see in the drawing to the right.

The cover is made out of a piece of $\frac{1}{4}$ " hardboard with some rabbeted hardwood edging to help hold it in place. Size the cover so that it just fits over the top of your saw. (Be sure to include the rip fence rails.) The cover protects the cast iron top of your saw from damage. And when you're not using it, you can simply remove the cover and hang it on the wall.

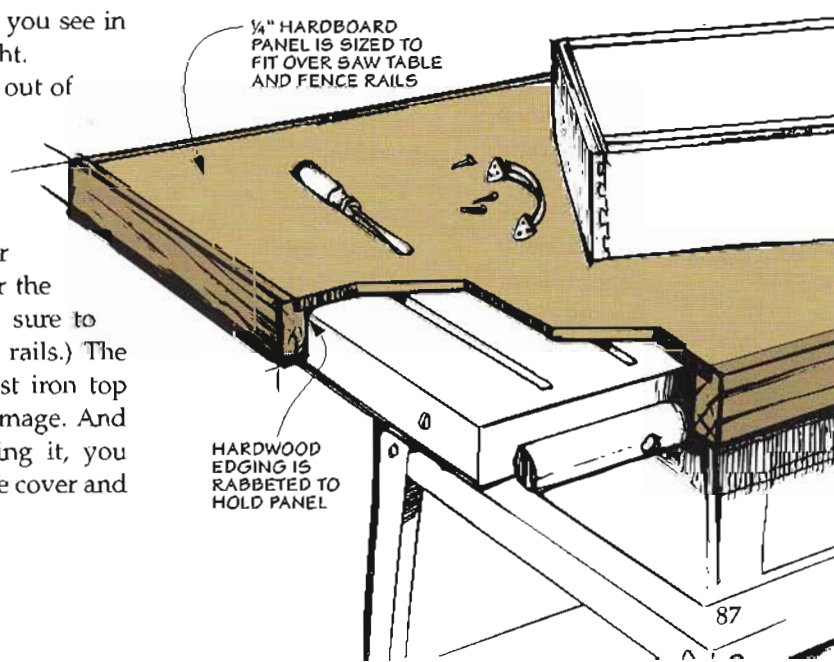

All-In-One Project Station

Maximize the capabilities of your table saw by transforming it into a workstation for sawing, routing, clamping, drilling, and assembly.

I don't know many woodworkers who aren't looking for a way to use the space in their shop more efficiently. So, if a single workstation can pull double or even triple duty, it's sure to be a hit.

The table saw upgrade shown here adds capabilities without taking up more valuable floor space. With the help of some hard-working accessories, I've turned an ordinary contractor's-style table saw into a versatile joinery, assembly, clamping, and routing station (inset photo). Throw in some storage shelves, a drawer, and tool holsters, and it becomes an all-in-one workshop powerhouse.



Routing Station. The router table extension replaces the left wing and includes a detachable router table fence.



Exploded View Details

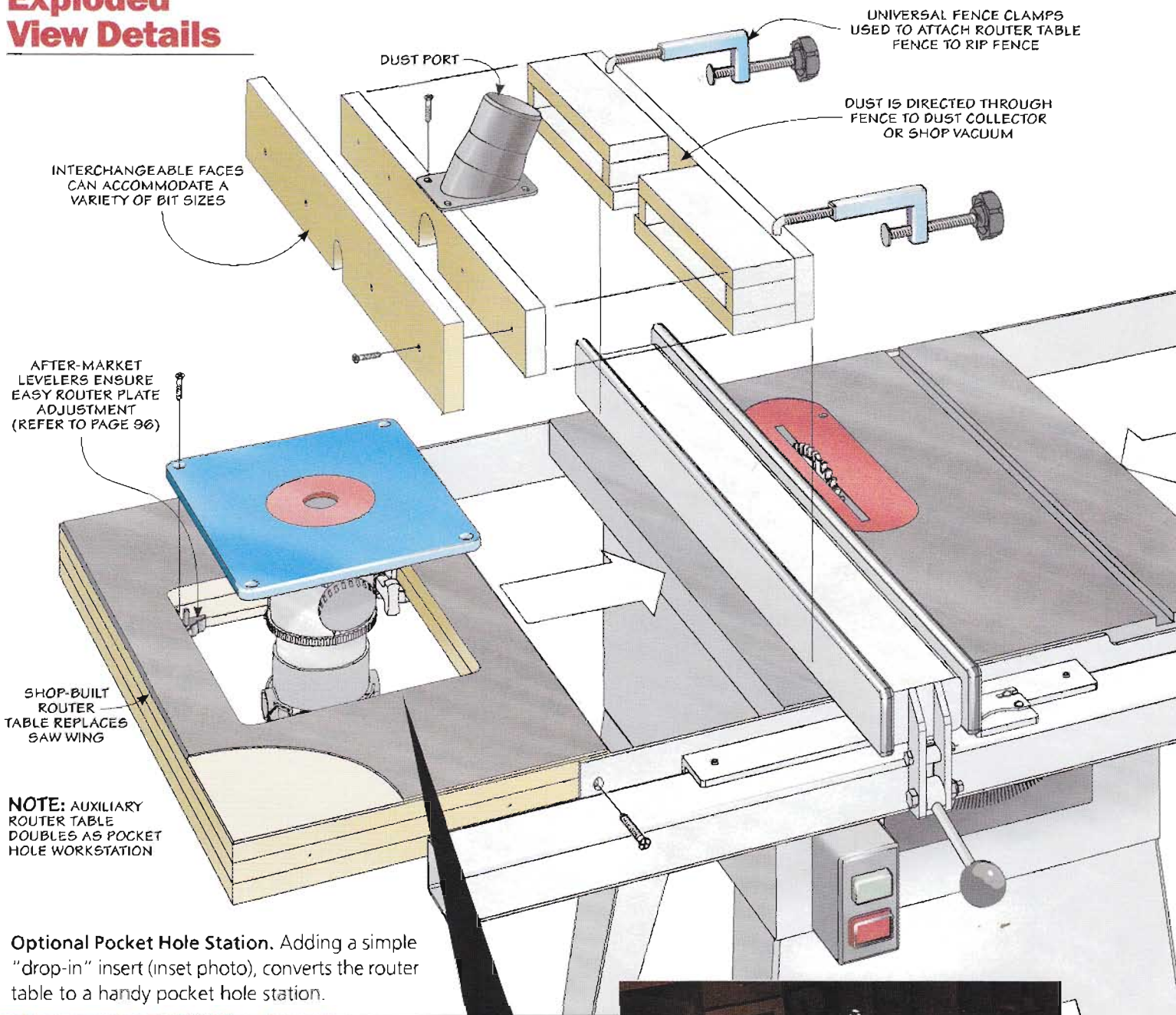

Optional Pocket Hole Station. Adding a simple "drop-in" insert (inset photo), converts the router table to a handy pocket hole station.

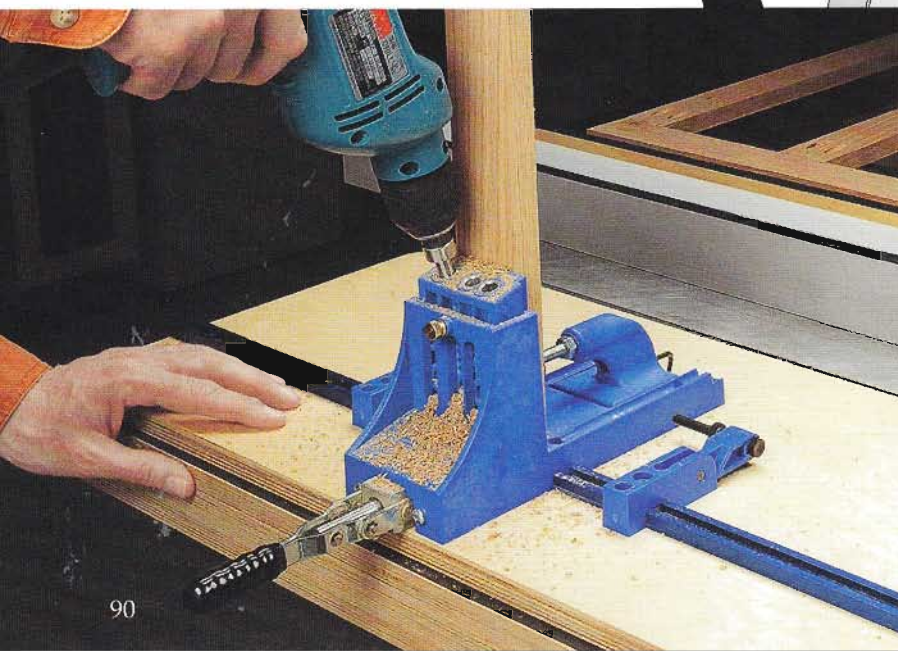

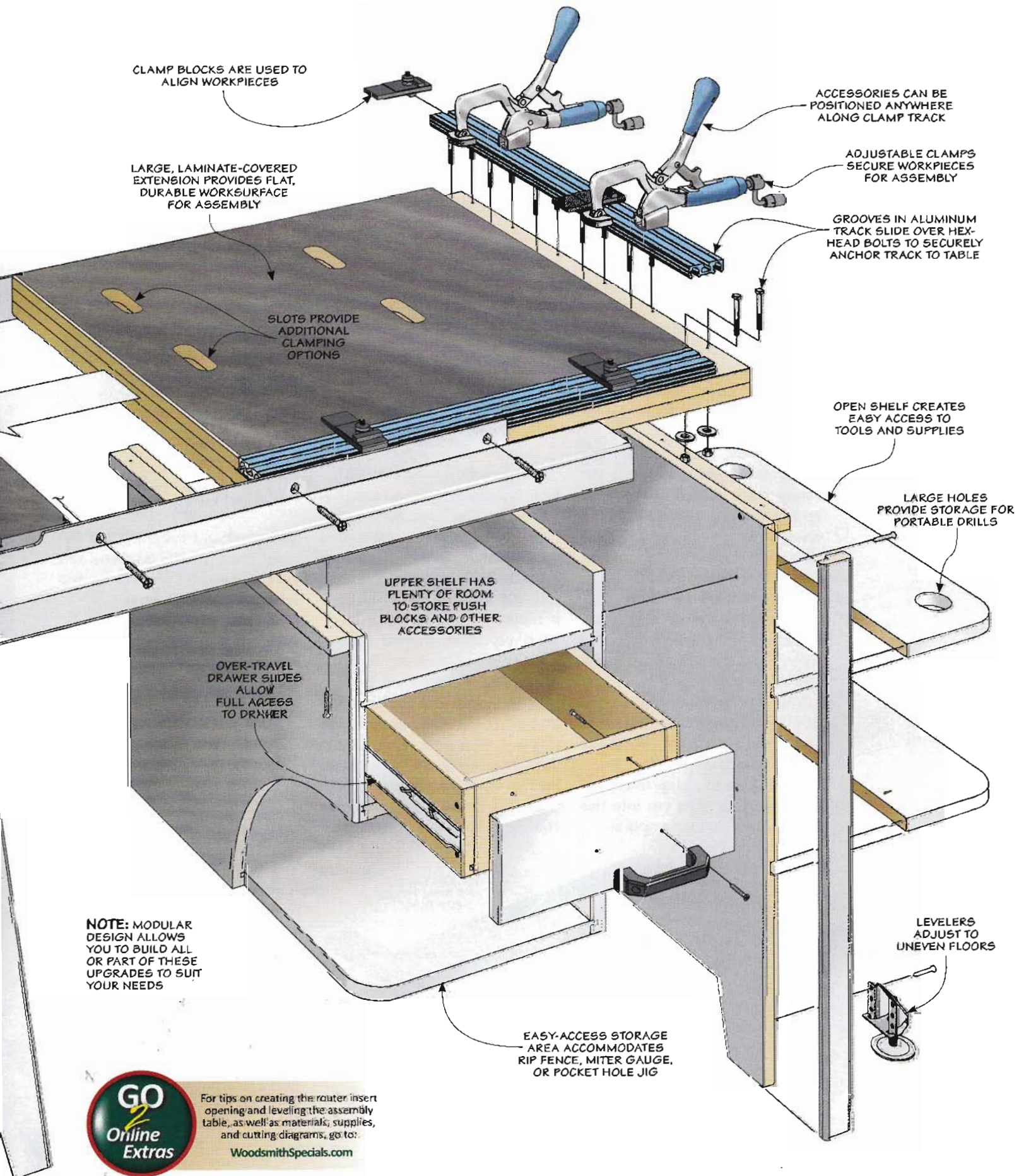

CLAMP BLOCKS ARE USED TO ALIGN WORKPIECES

ACCESSORIES CAN BE POSITIONED ANYWHERE ALONG CLAMP TRACK

LARGE, LAMINATE-COVERED EXTENSION PROVIDES FLAT, DURABLE WORKSURFACE FOR ASSEMBLY

ADJUSTABLE CLAMPS SECURE WORKPIECES FOR ASSEMBLY

SLOTS PROVIDE ADDITIONAL CLAMPING OPTIONS

GROOVES IN ALUMINUM TRACK SLIDE OVER HEX-HEAD BOLTS TO SECURELY ANCHOR TRACK TO TABLE

OPEN SHELF CREATES EASY ACCESS TO TOOLS AND SUPPLIES

LARGE HOLES PROVIDE STORAGE FOR PORTABLE DRILLS

UPPER SHELF HAS PLENTY OF ROOM TO STORE PUSH BLOCKS AND OTHER ACCESSORIES

OVER-TRAVEL DRAWER SLIDES ALLOW FULL ACCESS TO DRAWER

LEVELERS ADJUST TO UNEVEN FLOORS

EASY-ACCESS STORAGE AREA ACCOMMODATES RIP FENCE, MITER GAUGE, OR POCKET HOLE JIG

NOTE: MODULAR DESIGN ALLOWS YOU TO BUILD ALL OR PART OF THESE UPGRADES TO SUIT YOUR NEEDS



For tips on creating the router insert opening and leveling the assembly table, as well as materials, supplies, and cutting diagrams, go to: WoodsmithSpecials.com

Construct the Main Wing

One practical workshop layout places the table saw in the middle of the shop. It's a good rule that provides clearance for any size workpiece. The project station takes advantage of this placement by replacing the extension wing on the right side of the table saw with an assembly table.

ASSEMBLY TABLE WING. Before you get started, you'll need to size the depth (width) of the wing to fit your saw. The dimensions shown here are what I used to fit my contractor's saw.

One thing that makes this replacement wing unique is the clamp track located at the front and right edges of the table. I used an extruded aluminum track with slots on the bottom to mount it to the table with hex-head bolts. A slot on top holds adjustable locking clamps and other accessories anywhere along its length. Learn more about the accessories in the box on the next page.

This type of track is available through various manufacturers. You'll find sources for two kinds of clamp track on page 98.

In addition to clamp track, the wing has four slots cut into the top for extra clamping options.

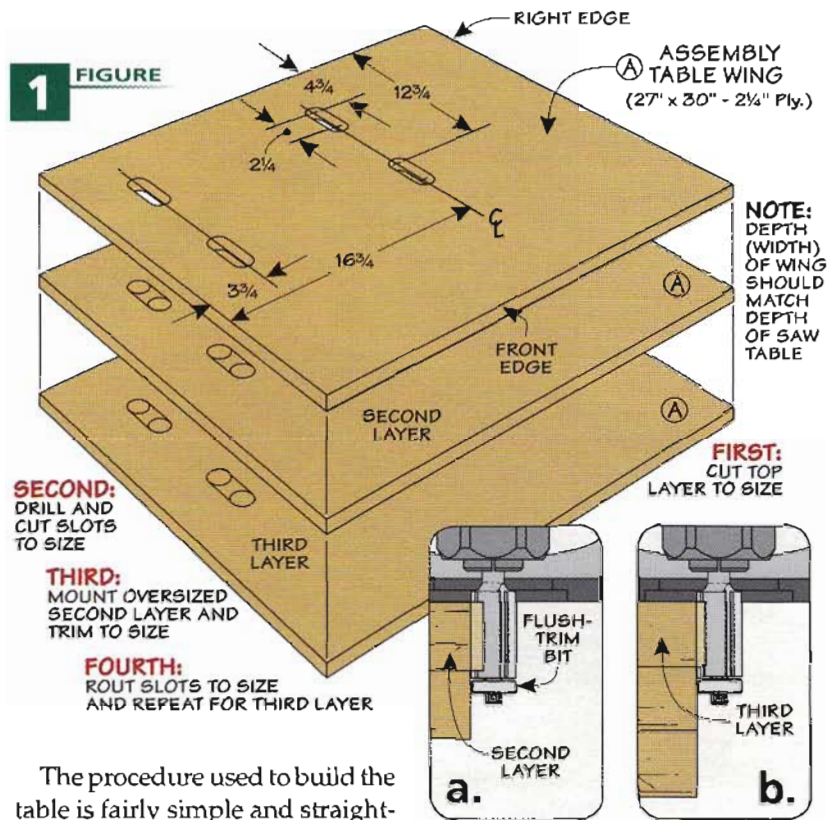

SECOND: DRILL AND CUT SLOTS TO SIZE

THIRD: MOUNT OVERSIZED SECOND LAYER AND TRIM TO SIZE

FOURTH: ROUT SLOTS TO SIZE AND REPEAT FOR THIRD LAYER

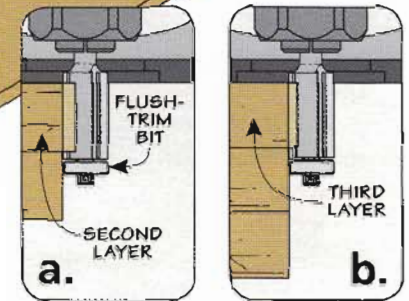

The procedure used to build the table is fairly simple and straightforward. The assembly table needs to be sturdy, so it makes sense to start by building up an extra-thick plywood base.

LAYERED TOP. The assembly table is made of three layers of Baltic birch plywood, topped with a sheet of plastic laminate. To make things easy, I cut the top layer to size, then laid out and cut the four clamping slots, as shown in Figure 1. This first workpiece is then used as a template to shape the two remaining pieces.

The key here is to add one layer at a time, cutting it just slightly

oversized and roughing out the slots. Then you can go ahead and bond the second piece to the top layer with contact cement.

To clean up the edges and the slots, use a router and flush-trim bit, as in Figure 1a. Then you can simply repeat the process for the last plywood layer (Figure 1b).

ADD A RABBET. Once the base is complete, you're ready to cut a rabbet for the clamp track shown in Figures 1 and 2. A dado blade is perfect for this job.

However, there's one thing you'll need to keep in mind here. You want the track to sit flush with or slightly below the top of the worksurface, so be sure to

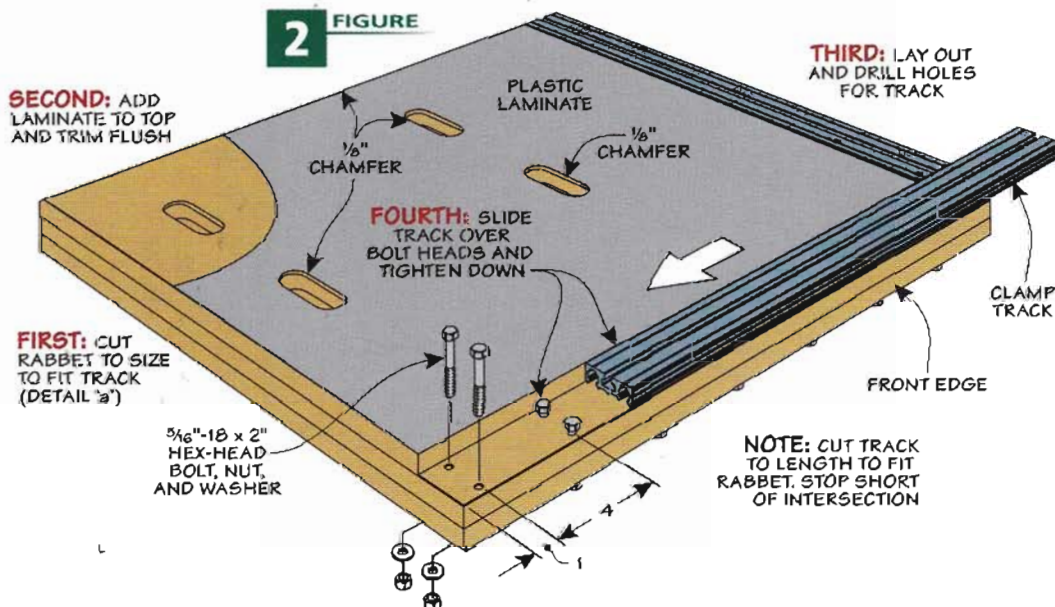

SECOND: ADD LAMINATE TO TOP AND TRIM FLUSH

FOURTH: SLIDE TRACK OVER BOLT HEADS AND TIGHTEN DOWN

FIRST: CUT RABBET TO SIZE TO FIT TRACK (DETAIL 'a')

5/16"-18 x 2" HEX-HEAD BOLT, NUT, AND WASHER

THIRD: LAY OUT AND DRILL HOLES FOR TRACK

NOTE: CUT TRACK TO LENGTH TO FIT RABBET. STOP SHORT OF INTERSECTION

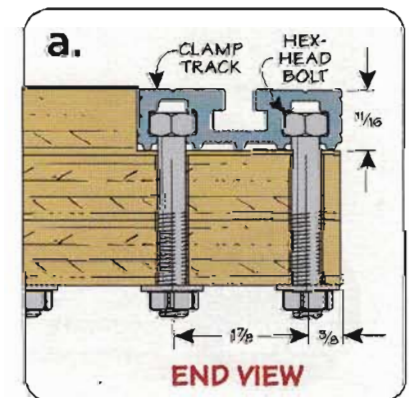

measure carefully and don't forget to account for the laminate, which will be added next.

PLASTIC LAMINATE. I wanted a smooth, durable worksurface for the assembly table, so I added a final layer of plastic laminate to the top, as shown in Figure 2.

With the laminate in place, carefully cut starter holes in the waste areas of the four clamping slots. Then, using a router and flush-trim bit, trim the laminate flush with the edges of the slots and around the outside of the top. Finally, switch over to a chamfer bit and rout a shallow chamfer along the edges of the slots as well as the back, exposed edge of the table (Figure 2).

ADD THE TRACK. The next step is to secure the track to the table. In order to do this, you need to drill a series of holes, as illustrated in Figure 2. What's important here is to pay close attention to the spacing of the mounting holes you're drilling. If the holes are spaced too far apart, the track may lift up from the table.

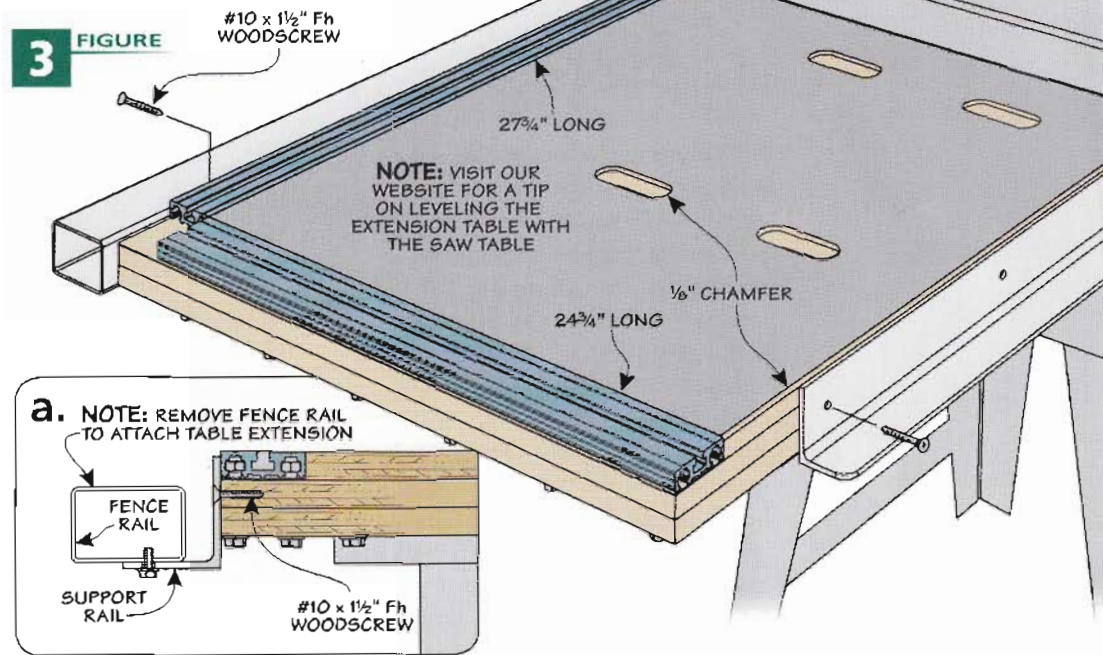

After cutting the track to length, install the hex-head bolts, washers, and nuts with a loose fit. Then, all that's left to do is slide the track in place over the bolt heads and tighten the nuts. You can see the track stops short of the corner where the two rabbets intersect. This allows you to add or remove accessories.

INSTALL THE ASSEMBLY TABLE. To install the table, you'll have to remove the wing that came with your saw, as well as the fence rail. Now, simply attach the table with wood screws, using the existing holes in the support rails (Figures 3 and 3a). You'll find more tips for leveling the assembly table with the saw table online.

Clamping Accessories

The features on this assembly table are as helpful as an extra workbench and another pair of hands in your workshop.

Clamping System. There are two ways to secure a project to the table. The first uses the clamp track to hold locking clamps, as shown in the photo at right. The slots in the track let you place a clamp where it's needed most. Plus, specially designed plastic blocks help align your workpieces. The adjustable blocks allow you to position both workpieces so that the center of the locking clamp head is directly over the joint line.

Table Slots. You also have the option of positioning the clamps in the middle of the assembly table. Four handy slots in the top of the table work great for positioning a bar clamp wherever you need a little extra support.

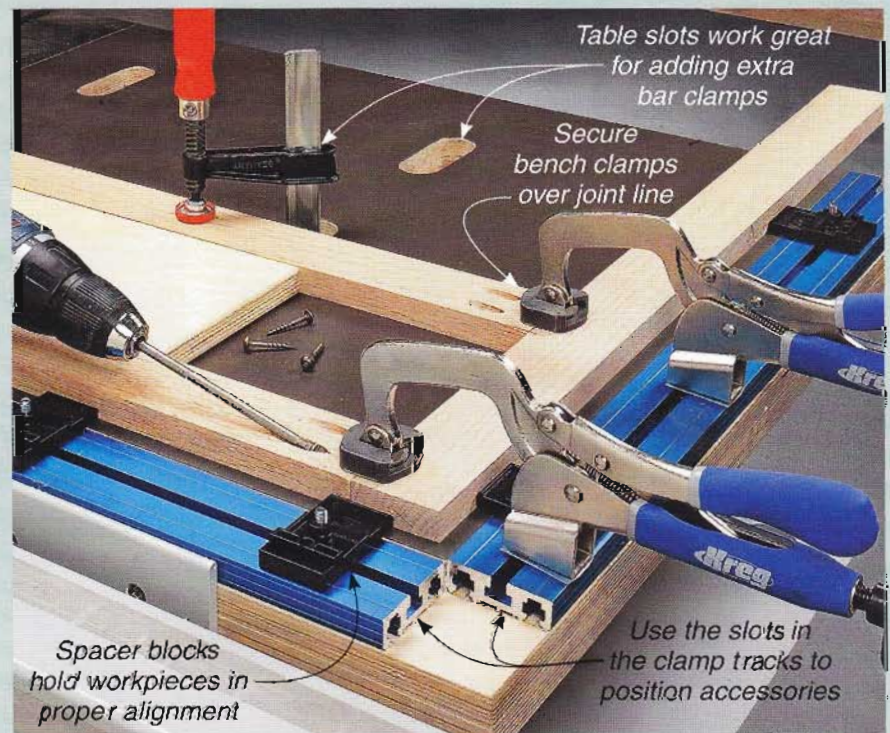

Creating Storage

With the main wing installed, it's time to add some support and storage underneath. To do this, I built a sturdy end assembly that's made up of a wide panel and two integral legs. A look at Figures 4 and 5 gives you the idea.

Adding a couple of narrow, open shelves provides some extra storage in this area. And two holes in the top shelf create quick-access "holsters" for cordless drills. Finally, to make it easy to adjust the end assembly on an uneven floor, there are a couple of heavy-duty leg levelers.

END ASSEMBLY

As you can see in Figure 4, I used a pair of dados in the end assembly to hold the shelves in place. The challenge is making sure the dados align once

4 FIGURE

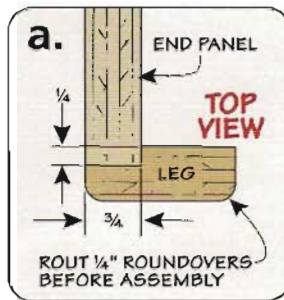

NOTE: END ASSEMBLY DADOES AND RABBETS ARE 1/4" DEEP

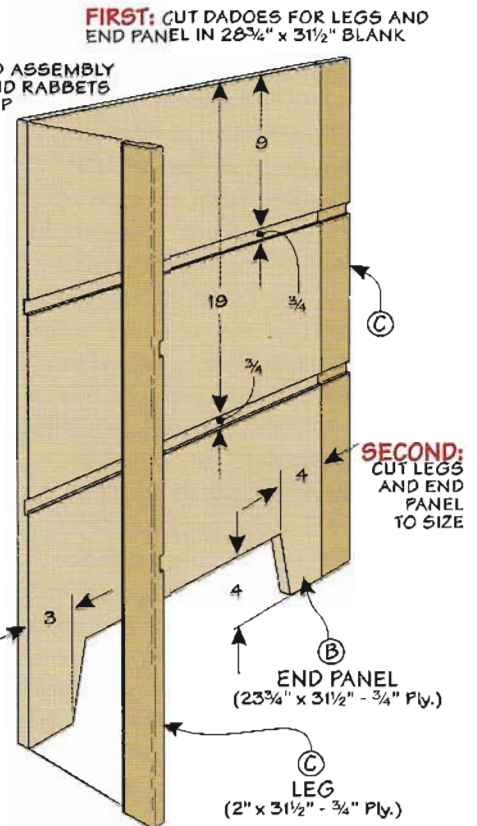

FIRST: CUT DADOES FOR LEGS AND END PANEL IN 28 3/4" x 31 1/2" BLANK

SECOND: CUT LEGS AND END PANEL TO SIZE

the legs and the panel are joined together.

OVERSIZED BLANK. To do this, I found it easier to cut the dados first in an oversized plywood blank. After the dados are cut, you can rip the two legs from the panel and trim the end panel to width, as shown in Figure 4. Figure 4a shows how I cut the rabbets and rounded over the outsides of the legs. Once the legs are complete, add a cutout at the bottom of the panel to create feet.

SHELVES. The shelves are a perfect place for supplies, and they're simple to make. First, cut them to size and add a small radius on the outside corners. Then, go ahead and drill holes sized to fit your drill chuck (Figure 5).

COMPLETE THE END ASSEMBLY. There are just a few last steps to complete before you can assemble and install the end panel below the assembly table. First, glue the legs and shelves to the panel.

Then, you can make it easier to fasten the end panel to the main wing by adding a small cleat at the top of the end panel assembly (Figures 5 and 5a). This is also a

Drill Holsters. Two holes drilled in the upper shelf provide storage and easy access to your drills.

5 FIGURE

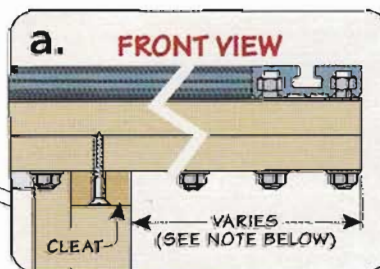
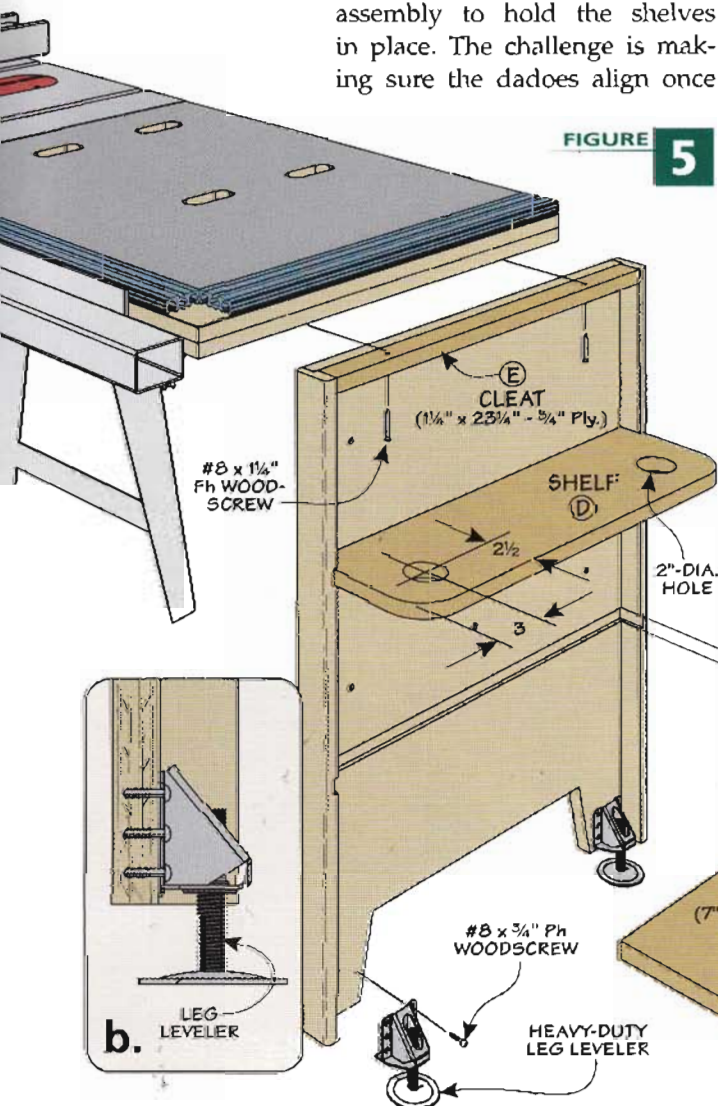

NOTE: IF YOU PLAN ON PLACING YOUR SAW AND EXTENSION TABLE ON A MOBILE BASE, BE SURE TO ADJUST SIZE AND POSITION OF END ASSEMBLY TO FIT



good time to drill the counter-sunk holes on the outside of the panel and the cleat, as shown in Figure 5. These holes are used later to attach the end assembly to the cabinet you'll build next.

If you're going to paint the assembly, now is the time to do it. Then, the next step is to add the leg levelers and mount the panel to the table with screws. You can see what I mean if you check out Figures 5 and 5b. If you're using a mobile base, be sure to position the end assembly so it fits onto the base extension.

CABINET ASSEMBLY

All the open space below the extension table creates another great opportunity for storage. So I added a cabinet featuring a large open bay, a storage shelf, and an easy-access drawer.

To make the cabinet, I used tongue and dado joinery, as you see in Figure 6. Start by cutting the sides to size. Each side has three grooves to hold the shelves. The upper and middle shelves form a drawer compartment and have a rabbet to hold a back.

BOTTOM SHELF & SIDE. If you take another look at Figure 6, you'll see that I added a large opening along the front edge of the left

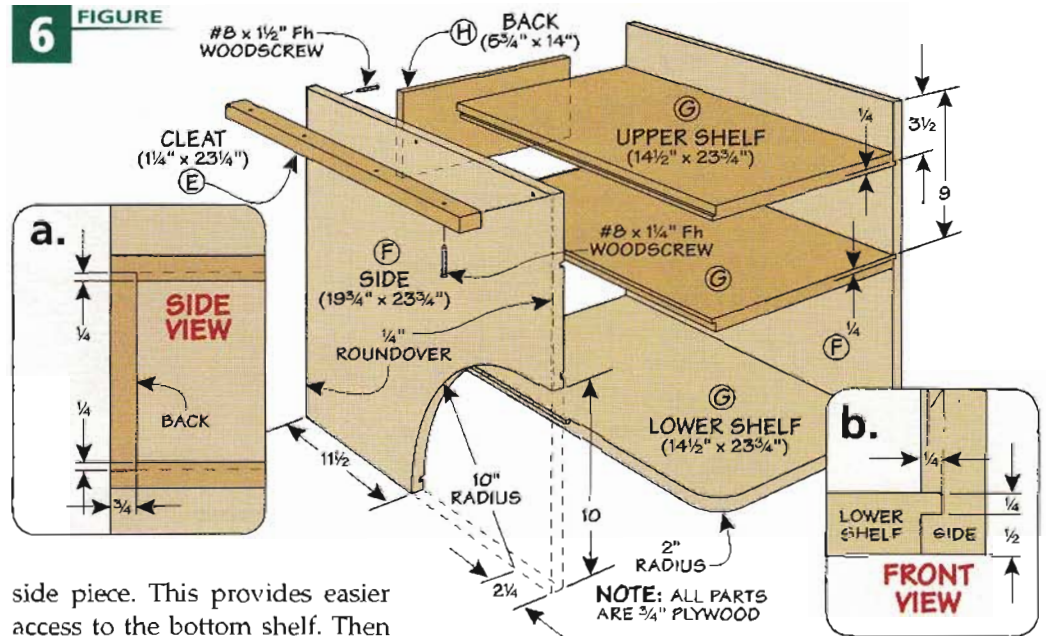

side piece. This provides easier access to the bottom shelf. Then just remove the exposed portion of the tongue on the lower shelf. I laid out the end point of the tongue and used a router and flush-trim bit to trim to the line. Finally, round the exposed corner of the bottom shelf.

ASSEMBLY. Now it's time to assemble the sides and shelves with glue. Also, cut a back piece to size, but wait until after you've built the drawer and installed the slides before gluing it in place.

Before you start on the drawer, paint the cabinet and attach it to the assembly table. I used a cleat and screws to do this (Figure 6).

DRAWER. The drawer provides a lot of good storage for accessories. But the deep overhang created by the fence rail limits access, so I used "over-travel" drawer slides to solve the problem (Figure 7b).

Tongue and dado joinery (with a groove on the inside for the bottom) works well for the drawer. Just be sure to account for the slides when you size the parts. Then add screws to reinforce the joinery. Finally, after installing the slides and the false front, add a pull to complete the cabinet.

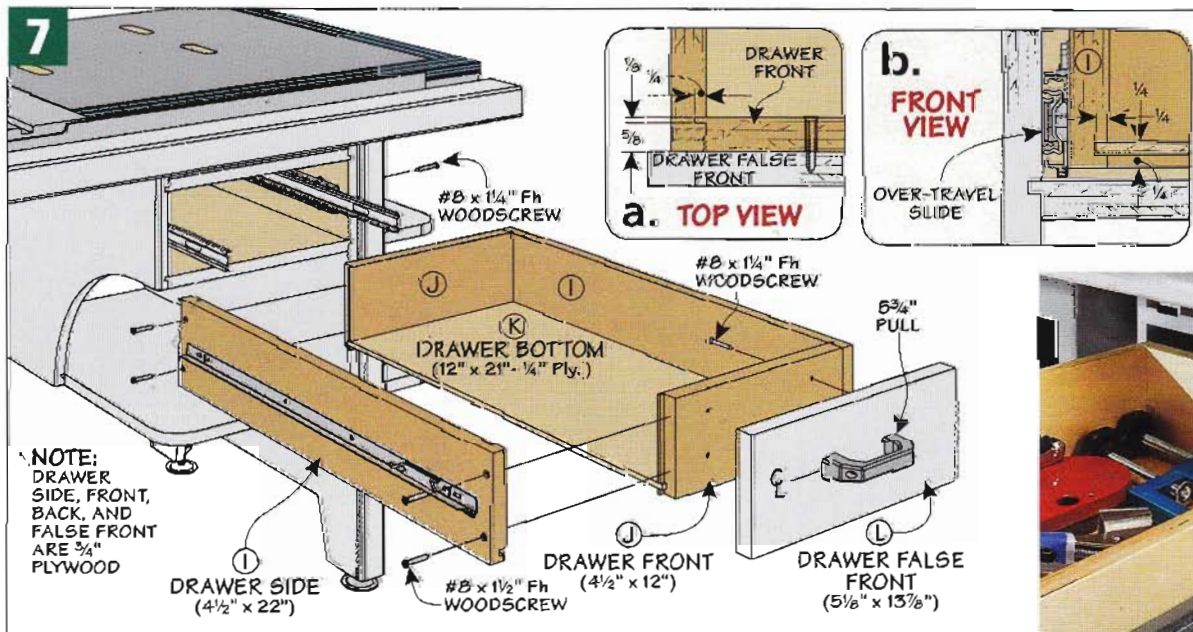

Over-Travel Slides. These drawer slides provide plenty of access to the back of the deep drawer.



Router Table Extension

One of the things I like most about this project is it really turns your table saw into a multi-purpose workstation. The router table extension and fence are proof of that (photo on opposite page).

Even though it takes up a small amount of space, this router table is big enough for most routing operations. And the router table fence attaches to the table saw rip fence using universal fence clamps. This way, it can easily be locked in place wherever it's needed, as shown in the photo on the opposite page. Plus, the clamps make it easy to remove the fence and store it in no time at all.

DRILLING STATION. To get more out of the router table extension, the wing doubles as a pocket hole drilling station. I mounted my pocket hole jig to an auxiliary base, then added a simple plywood insert that fits into the opening

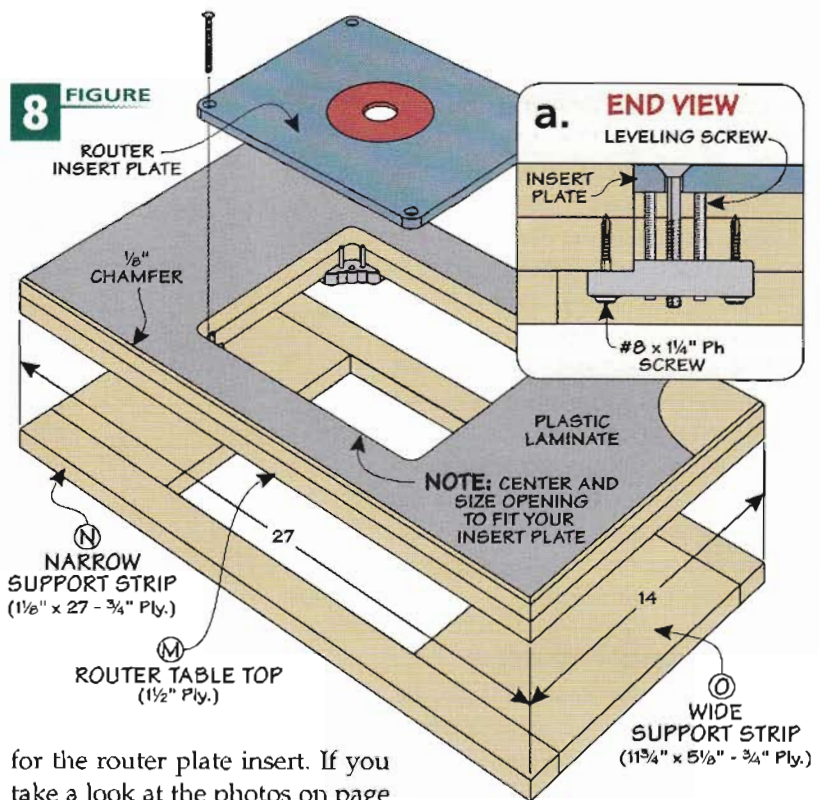

for the router plate insert. If you take a look at the photos on page 90, you'll see what I mean.

CONSTRUCTION DETAILS. I used a lot of the same techniques to build this table as I did on the assembly table, with a few small changes.

First of all, the router table has just two full-size layers of 3/4 inch plywood. And as before, I cut the

first layer to size, then used it as a template to complete the second. But instead of slots, I added an insert plate opening (photo below). To learn how to do this, visit WoodsmithSpecials.com.

PLATE LEVELERS. In the inset photo below, you'll see the insert plate levelers I used. These levelers are designed to work on router table tops up to 1 1/2 inch thick. After installing them, I added four support strips to create a "third layer" for the top (Figure 8). This provides



Leveling Hardware. These levelers make adding and leveling an insert plate easy work.

Materials & Hardware

ASSEMBLY TABLE WING & STORAGE

A	Assembly Table Wing (1)	2 1/4 ply. - 27 x 30
B	End Panel (1)	3/4 ply. - 23 3/4 x 31 1/2
C	End Legs (2)	3/4 ply. - 2 x 31 1/2
D	Shelves (2)	3/4 ply. - 7 x 23 3/4
E	Cleats (2)	3/4 ply. - 1 1/4 x 23 1/4
F	Cabinet Sides (2)	3/4 ply. - 19 3/4 x 23 3/4
G	Cabinet Shelves (3)	3/4 ply. - 14 1/2 x 23 3/4
H	Cabinet Back (1)	3/4 ply. - 5 3/4 x 14
I	Drawer Sides (2)	3/4 ply. - 4 1/2 x 22
J	Drawer Front/Back (2)	3/4 ply. - 4 1/2 x 12
K	Drawer Bottom (1)	1/4 ply. - 12 x 21
L	Drawer False Front (1)	3/4 ply. - 5 1/8 x 13 7/8

ROUTER TABLE WING & FENCE

M	Router Table Top (1)	1 1/2 ply. - 14 x 27
N	Narrow Support Strips (2)	3/4 ply. - 1 1/8 x 27
O	Wide Support Strips (2)	3/4 ply. - 11 3/4 x 5 1/8
P	Fence Back/Frt./Btm. (3)	3/4 ply. - 2 1/2 x 24
Q	Fence Tops (2)	3/4 ply. - 2 1/2 x 10 1/4
R	Fence Filler Blocks (4)	3/4 ply. - 1 x 2 1/2
S	Fence Face (1)	3/4 MDF - 3 1/4 x 27

- (6) #8 x 1 1/2" Fh Woodscrews
- (10) #8 x 1 1/4" Fh Woodscrews
- (24) #10 x 1 1/2" Fh Woodscrews
- (12) #8 x 1 1/4" Fine Ph Screws
- (16) #8 x 3/4" Ph Screws
- (2) Clamp Tracks (33 3/4" long)
- (1 set) Clamp Blocks
- (2) 3" Locking Bench Clamps
- (1) Router Plate
- (4) Router Plate Levelers
- (2) Universal Fence Clamps
- (1) Dust Port
- (2) Heavy-Duty Leg Levelers
- (1 pr.) 22" Over-Travel Drawer Slide
- (1) 1 17/32" x 5 3/4" Drawer Pull w/Screws
- (26) 5/16" - 18 x 2" Hex-Head Bolts
- (26) 5/16" - 18 Hex Nuts
- (26) 5/16" Washers

some additional strength to the table and gives it the built-up look that I wanted.

To complete the router table extension, I added plastic laminate to the top of the table. After trimming it flush, I routed a small chamfer on the top front and side edges of the router table extension (Figure 8). To match the assembly table, I left the edges of the plywood unpainted.

BUILD THE FENCE

Next you'll need to add a sturdy router table fence. There are several things I like about this design. First, it's easy to build, with no fancy joinery. Second, the integral dust channel whisks chips up through the fence and out to a vacuum or dust collector.

Another nice feature of this fence is its replaceable face. You can easily make extras to keep on hand. The face is just a piece of MDF with an opening sized for your most common bits.

Finally, I used special clamps to attach the fence to the rip fence. Where other clamps might be in the way, these clamps keep

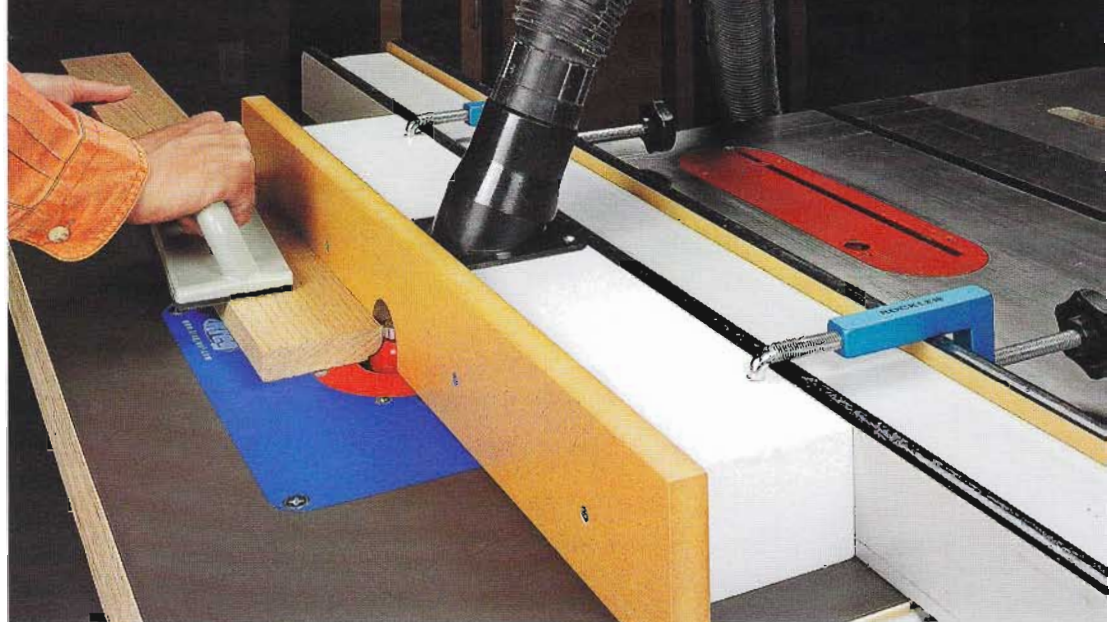

the fence face unobstructed, as in Figure 9 and the photo above. For sources, turn to page 98.

BASIC FENCE. If you take a look at Figure 9, you'll see how the fence base is made. The idea is to make an opening big enough for the dust port, while at the same time providing a solid base for clamping everything to the rip fence.

Go ahead and cut the base pieces to size, but before you glue them up, make the notches in the bottom and front pieces. To do this, I simply drilled a hole and then removed the waste.

Once you've cut everything to size, you can glue up the pieces, paint everything but the face, and drill two holes on the back edge of the fence for the clamps.

Now you can work on making some replaceable faces. The size of the opening should accommodate your most commonly used bits. Finally, fasten the face in place and add the dust port.

This table saw workstation makes your saw capable of more than ever before. And it only takes a few days to complete.

Router Table Fence. Held to the rip fence with special clamps, the fence is easy to install and remove.

9 FIGURE

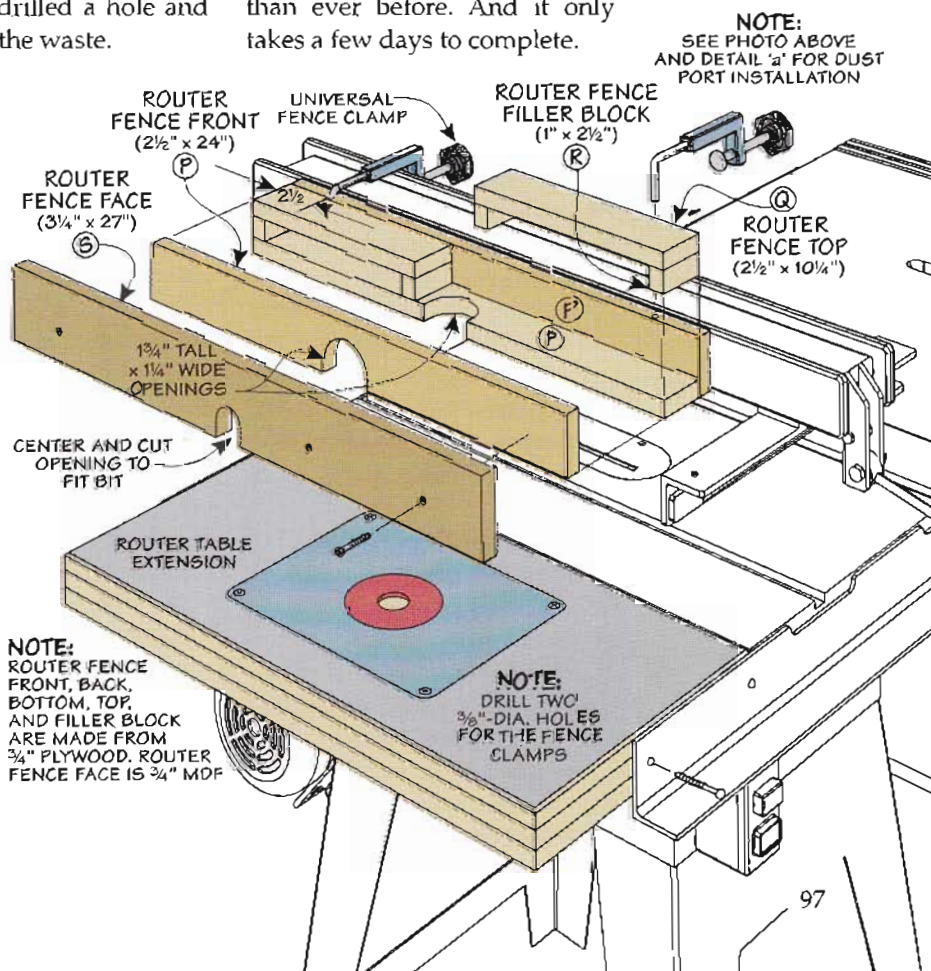
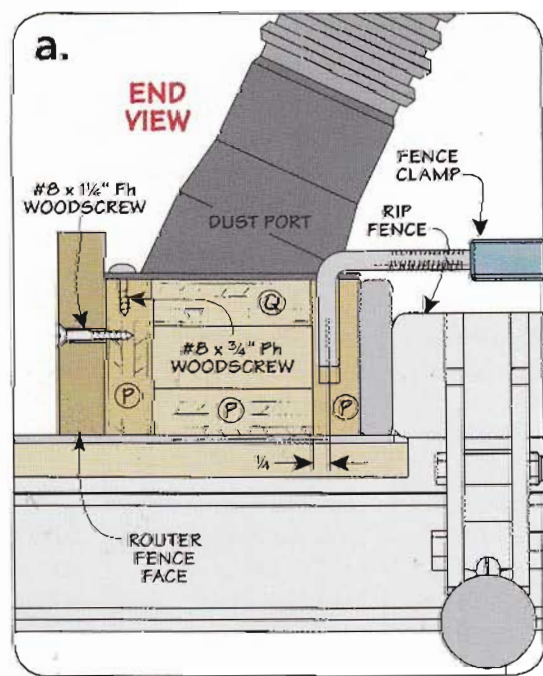

NOTE: SEE PHOTO ABOVE AND DETAIL 'a' FOR DUST PORT INSTALLATION

NOTE: ROUTER FENCE FRONT, BACK, BOTTOM, TOP, AND FILLER BLOCK ARE MADE FROM 3/4\"/>

NOTE: DRILL TWO 3/8\"/>

Table Saw Secrets Sources

MAIL ORDER SOURCES

Woodsmith Store
800-444-7527

Rockler
800-279-4441
rockler.com

Kreg Tool
800-447-8638
kregtool.com

Lee Valley
800-871-8158
leevalley.com

Mike's Tools
714-558-8737
mikestools.com

Reid Supply
800-253-0421
reidsupply.com

SkyGeek
skygeek.com

Woodcraft
800-225-1153
woodcraft.com

Woodhaven
800-344-6657
woodhaven.com

Woodpeckers
800-752-0725
woodpeck.com

Most of the materials and supplies you'll need for projects in this book are available at hardware stores or home centers. For specific products or hard-to-find items, take a look at the sources and part numbers listed here.

I should also mention that manufacturers and retailers periodically redesign or discontinue items. So, you'll want to gather all the hardware you need before you get started. It's easy to adjust dimensions or drill different sized holes to suit your hardware.

TABLE SAW TUNE-UP

As you see on page 8, a dial indicator is an important gadget to have for a table saw tune-up. The dial indicator shown (128397) was ordered from *Woodcraft*.

BLADE CLEANING

We reveal our test results for blade cleaners on page 20. You can find *Lestoil Grease and Stain Remover* at *Ace Hardware Stores*. *Extreme Simple Green Aircraft and Precision Cleaner* can be ordered from online retailer *SkyGeek*. And *Rockler* sells its own *Saw Blade Cleaning Kit* (63895).

CUTTING PERFECT CIRCLES

Many of the items we used for the circle-cutting jig on page 44 came from *Rockler*, including the 5-star knob with insert (23812), the 6' R-to-L measuring tape (69124), and the *Hold-Down Clamp Kit* (21912). The *Freud* calibration disk is available at the *Woodsmith Store* (222512).

PRECISION CROSSCUT SLED

I ordered the following supplies for the crosscut sled on page 52:

- **Runner**
Kreg KMS7303
Woodsmith Store 273736
- **Fence Track**
Kreg KMS7712
Woodsmith Store 273733
- **Flip Stop**
Kreg KMS7801
Woodsmith Store 273729
- **Measuring Tape (L-to-R)**
Kreg KMS7724
Woodsmith Store 273740
- **Micro-Adjuster**
Kreg KMS7215
Woodsmith Store 618033
- **Knobs**
Reid Supply DK-228
- **Cross Dowels**
Rockler 31823
Woodsmith Store 454269

RIP FENCE ACCESSORY SYSTEM

When building the rip fence accessory system featured on page 60, I ordered the 5/16"-18 knobs with insert (*RST-94*) and 5/16"-18 knobs with 1" stud (*RST-99*) from *Reid Supply*.

SMALL PARTS JIG

All the parts you'll need to build the small parts jig on page 66 are available from *Lee Valley*:

- 36" T-Track 12K79.24
- 1/4"-20 T-Slot Nuts 05J21.15
- 1/4"-20 x 1" T-Bolt 12K79.70
- 1/4"-20 Inserts 00M90.01
- 1/4"-20 Knob w/1" Stud 00M51.02
- 1/4"-20 Knob w/Insert 00M51.01
- Tapered Handle w/Stud 00M53.02
- 12" Centering Rule 60N46.02

TABLE SAW WORKCENTER

Building a versatile workcenter (page 74) requires an assortment of materials and hardware.

The corner levelers (31217) for the cabinet, spring hinges (28845) for the doors, and 16" *Accuride* drawer slides (32482) were all purchased from *Rockler*.

The 5/16" star knobs (*DK-685*) for the router table fence, as well as the drawer handles (*DUH-50*), were ordered from *Reid Supply*.

You'll also need to get the phenolic router plate (147) from *Woodhaven*, and you can find the *Rockler* dust collection port (35317) at the *Woodsmith Store*. The *Rousseau* miter gauge track (0048) came from *Mike's Tools*.

To create a finished edge at the top of the workcenter, I ordered the 1 1/2" black T-molding (*T-BLA-150*) from *T-molding.com*.

PROJECT STATION

You can get the supplies you need for the project station on page 88 from these sources:

- **Woodsmith Store**
Klamp Trak 618057
Klamp Blocks 618059
Bench Klamps (3") 415585
Router Insert Plate 618062
Insert Plate Levelers 618063
- **Woodpeckers**
Dual Purpose Track DPTRACK36
- **Rockler**
Over-Travel Drawer Slides 30812
Universal Fence Clamps 31373
Leg Levelers 81239
Dust Port 92031
- **Reid Supply**
Drawer Pull DUH-55

Get these Best-Selling Books — only \$9.95 with **FREE** Shipping!

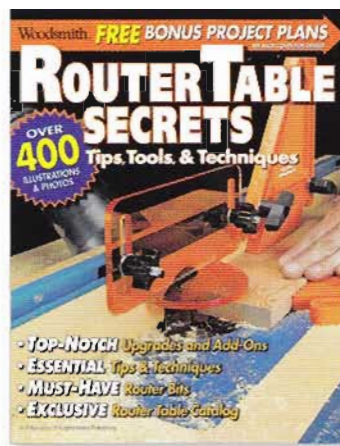
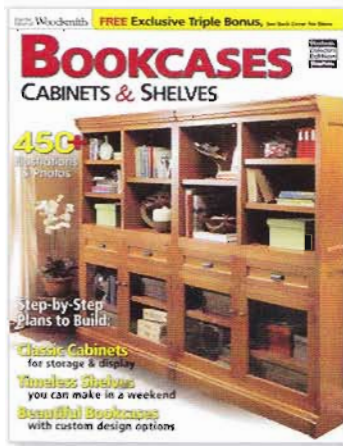

These and other woodworking books available at Woodsmith.com



Sign-Up Now and get Free *Woodsmith Tips!*

- Shop-tested printer-friendly tips
- NEW video tips & techniques
- Slide shows of great new products

Yours free at Woodsmith.com

Yours **FREE** at WoodsmithSpecials.com

Table Saw SECRETS

EXCLUSIVE FREE Online TRIPLE BONUS!

✓ 1. **FREE**

10 Table Saw Jig Plans

Easy-to-build jigs to make your work faster, safer, and more accurate.

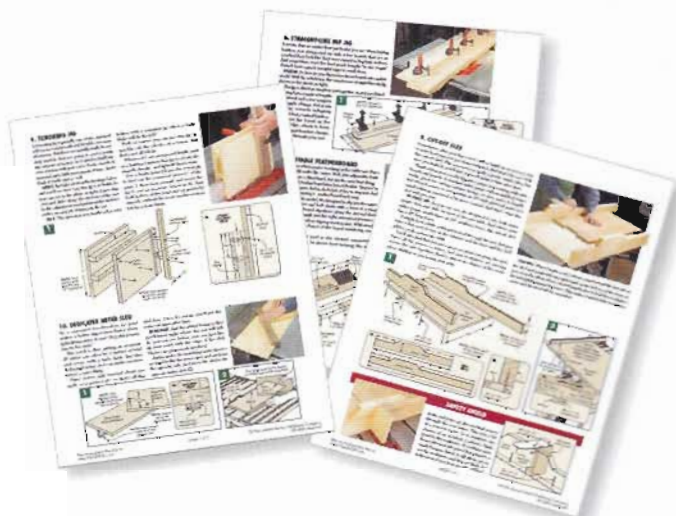

✓ 2. **FREE**

10 Table Saw Videos

See the tips, tricks, and secrets to make you a better woodworker.



✓ 3. **FREE**

100+ Table Saw Tips & Techniques

Quick and easy tips and techniques for getting the most out of your table saw.



Immediate on-line access for buyers of Table Saw Secrets

To get all your **FREE** bonus material go to WoodsmithSpecials.com
and enter this access code: