

**GEL VARNISH: ALMOST THE PERFECT FINISH**

Stash Trash With  
A Recycling Station



# POPULAR WOODworking

Learn How. Discover Why. Build Better.

DECEMBER 2009 #180

## PINT-SIZE DRILLS PACK A PUNCH

We Test 6 To Find  
The Best Borer

Shaker-Inspired  
Cherry Bookcase  
Plans Inside

The 12 Best New  
Tools of 2009

Boomerangs!  
Build 1 (or 100)  
This Weekend

popularwoodworking.com



twmedia US \$5.99

12

0 74470 01355 6

Display until January 11, 2010

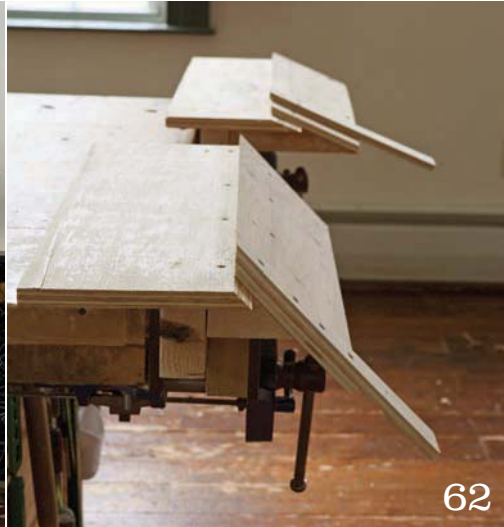

### 36 Compact 12v Drill-drivers

We test six compact 12-volt drill-drivers to see which one bores and screws the best – for the best price.

BY GLEN D. HUEY

### 42 Sam Maloof

Sam Maloof died in May 2009, but his legacy lives on through his iconic, elegant furniture.

BY JOHN ECONOMAKI

### 44 James Krenov

Though James Krenov died in September 2009, his philosophy and influence will continue through his students and books.

BY RON HOCK

### 46 Bibliophile's Bookcase

This large Shaker-inspired bookcase provides plenty of storage for your favorite stories, with two drawers to boot.

BY MEGAN FITZPATRICK

### 52 Build a Boomerang

Making a boomerang (or a bunch of them) is simple and fast – and these fun projects will set your head spinning.

BY TREVOR SMITH

### 57 2009's Best New Tools

One of the bright spots of an otherwise dismal economic year is that small tool companies have turned out some amazing new products.

BY CHRISTOPHER SCHWARZ



57



### 62 Shooting Boards

Small work is safer – and easier – to size when you work with a handplane and a well-made shooting board.

BY MICHAEL DUNBAR

### 66 Seamless Curved Panel Glue-ups

With careful layout, you'll be able to hide seams on the widest panels, even when the grain throws you a curve.

BY MARIO RODRIGUEZ

Number 180, December 2009. *Popular Woodworking* (ISSN 0884-8823, USPS 752-250) is published 7 times a year, which may include an occasional special, combined or expanded issue that may count as two issues, by F+W Media, Inc. Editorial and advertising offices are located at 4700 E. Galbraith Road, Cincinnati, Ohio 45236; tel.: 513-531-2222. Unsolicited manuscripts, photographs and artwork should include ample postage on a self-addressed, stamped envelope (SASE); otherwise they will not be returned. Subscription rates: A year's subscription (7 issues) is \$19.96; outside of the U.S. add \$7/year • Canada Publications Mail Agreement No. 40025316. Canadian return address: 2835 Kew Drive, Windsor, ON N8T 3B7 • Copyright 2009 by *Popular Woodworking*. Periodicals postage paid at Cincinnati, Ohio, and additional mailing offices. Postmaster: Send all address changes to *Popular Woodworking*, P.O. Box 420235, Palm Coast, FL 32142-0235 Canada GST Reg. # R122594716 • Produced and printed in the U.S.A.

REGULARS



**10** The Felling of  
3 Giant Oaks  
**OUT ON A LIMB**  
BY CHRISTOPHER SCHWARZ

**12** One Editor's  
Method to  
Sharpen a Scorp  
**LETTERS**  
FROM OUR READERS

**16** Safer Sheet-  
Goods Sawing  
**TRICKS OF THE TRADE**  
FROM OUR READERS

**20** Hidden in  
Plain Sight  
**ARTS & MYSTERIES**  
BY ADAM CHERUBINI

**24** Recycling  
Station  
**I CAN DO THAT**  
BY MEGAN FITZPATRICK

**26** Get the Most  
From Your  
Router  
**THE WOOD WHISPERER**  
BY MARC SPAGNUOLO

**28** SawStop  
Professional  
Cabinet Saw  
**TOOL TEST**  
BY OUR STAFF

**70** Coping at the  
Router Table  
**JIG JOURNAL**  
BY ROBERT W. LANG

**74** Gel Varnish  
**FLEXNER ON FINISHING**  
BY BOB FLEXNER

**80** But Aren't You a  
Woodworker?  
**OUT OF THE WOODWORK**  
BY ETHAN SINCOX

ON THE  
DECEMBER  
COVER



Small, lightweight 12-volt drill-drivers are up to just about any typical shop task, and they're less expensive than their larger brethren. Page 36.

COVER PHOTO BY AL PARRISH



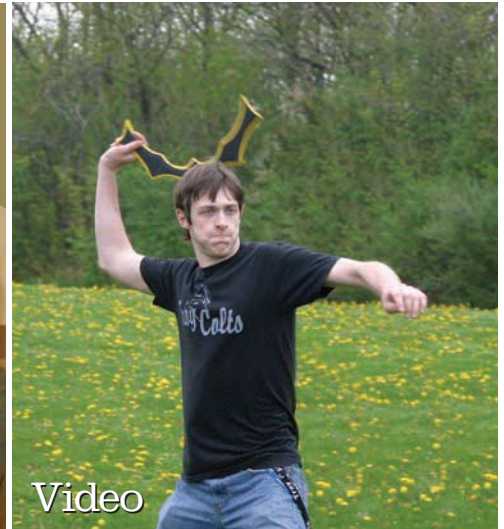
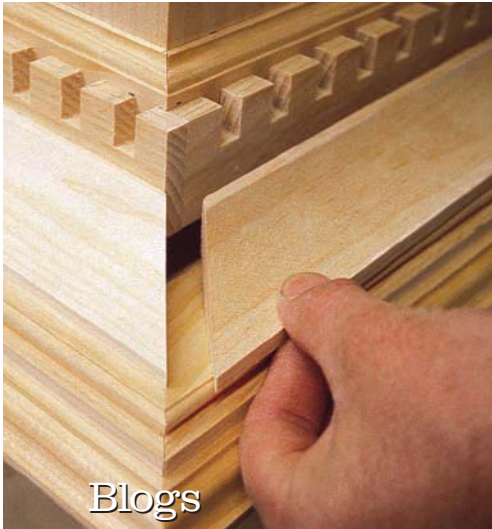

## New On the Blog

### Crown Moulding Installation

Senior Editor Glen D. Huey has a clever method for installing crown moulding on casework. You can read about it on our blog. [popularwoodworking.com/dec09](http://popularwoodworking.com/dec09)

## On the Web Site

### Legendary Rocker

We had the privilege of visiting with Sam Maloof in his workshop in 2003 just after he moved from his original Alta Lomo, Calif., location. You can read the Great Woodshops story free, on our web site. [popularwoodworking.com/dec09](http://popularwoodworking.com/dec09)

## Video Gallery

### Boomerangs in Flight

Trevor Smith's students combine woodworking with classroom learning to discover how edge shapes help to make their work fly. Watch them as they send their projects soaring. (Check out page 52 in this issue for the story.) [popularwoodworking.com/video](http://popularwoodworking.com/video)

### College of the Redwoods

James Krenov's teaching led to his founding the Fine Woodworking Program at the College of the Redwoods in Fort Bragg, Calif. We visited the school in 2007, the 25th anniversary of the woodworking program. You can read the Great Woodshops story free, on our web site. [popularwoodworking.com/dec09](http://popularwoodworking.com/dec09)

### Router Basics

Marc Spagnuolo (a.k.a. The Wood Whisperer) shows you the basics of using a router – one of the most handy tools in a powered shop. You'll discover how to rout perfect profiles and keep your bits cutting as if they're fresh from the package. [popularwoodworking.com/video](http://popularwoodworking.com/video)

 [popularwoodworking.com](http://popularwoodworking.com)

- [Contact Customer Service](http://popularwoodworking.com/customer-service)
- [Free Project Plans](http://popularwoodworking.com/projects)
- [Article Index](http://popularwoodworking.com/articleindex)
- [Tool Reviews](http://popularwoodworking.com/tools)
- [Editor Blogs](http://popularwoodworking.com/blogs)
- [Writer's Guidelines](http://popularwoodworking.com/writersguidelines)
- [Contact the Staff](http://popularwoodworking.com/contactus)

### 18-volt Lithium-ion Drills

In this issue, we test six 12-volt compact Lithium-ion drill-drivers (page 36). But if you're in the market for a larger tool with a bit more power, take a look at our 18-volt drill-driver test from April 2008 – it's free on our web site. [popularwoodworking.com/dec09](http://popularwoodworking.com/dec09)



### And More!

Visit [popularwoodworking.com/dec09](http://popularwoodworking.com/dec09) to find a complete list of all the online resources for this issue – including videos, additional drawings and photos.

**Trevor Smith** A good middle-school shop teacher got Trevor hooked on woodworking. Now, after years in his own shop and in classes with Alan Lacer, David Marks, Garrett Hack and the like, he enjoys making unique pieces for his home and shop, including a custom workbench, band saw boxes and a plane box, as well as “commissioned” pieces for his brother’s professional kitchen. He also teaches sharpening at his local Woodcraft store, and has to sharpen all his children’s kitchen knives. Recently, he’s been teaching woodworking to his oldest granddaughter, and has become interested in turning.

By day, Trevor is a physics teacher who values the process of learning through doing – as his students do when they build boomerangs (the story is on page 52).



**Ethan Sincox** Fairly new to woodworking, Ethan aspires to the level of quality and attention to detail his grandfather achieved as a life-long woodworker and artist.

When Ethan isn’t providing software support, working on his honey-do list or editing the St. Louis Woodworkers Guild newsletter, he is always looking for ways to combine his joys in life – kilts, writing and woodworking. He spends his occasional bit of free time hunting for old tools at estate sales and auctions. You can read more about his work at [greystonegreen.blogspot.com](http://greystonegreen.blogspot.com).

In this story, his first for *Popular Woodworking*, Ethan muses about the woodwork- ing he doesn’t like to do (page 80).



**Christopher Schwarz** In addition to his full-time job as editor of *Popular Woodworking* and *Woodworking Magazine*, Chris has his own publishing company, Lost Art Press. For this issue of the magazine, he wrote the “Best New Tools of 2009” story on page 57. In his spare time, he’s been working on reprinting “The Joiner and Cabinet Maker,” a charming tale from 1839 that tells the story of young Thomas, an apprentice in an early 19th-century rural English shop. It’s the earliest book to give detailed instruction on the basics of hand-tool woodworking, and the original has been reprinted along with step-by-step instruction from Chris on building the projects therein, with detailed footnotes and a chapter on early 19th-century British history by Joel Moskowitz. Find out more about the book and read an excerpt at [lostartpress.com](http://lostartpress.com).



DECEMBER 2009, VOL. 29, NO. 7

[popularwoodworking.com](http://popularwoodworking.com)

EDITORIAL OFFICES 513-531-2690

**PUBLISHER & GROUP EDITORIAL DIRECTOR**

Steve Shanesy

**EDITOR** Christopher Schwarz

x11407 ■ [chris.schwarz@fwmedia.com](mailto:chris.schwarz@fwmedia.com)

**ART DIRECTOR** Linda Watts

x11396 ■ [linda.watts@fwmedia.com](mailto:linda.watts@fwmedia.com)

**SENIOR EDITOR** Robert W. Lang

x11327 ■ [robert.lang@fwmedia.com](mailto:robert.lang@fwmedia.com)

**SENIOR EDITOR** Glen D. Huey

x11293 ■ [glen.huey@fwmedia.com](mailto:glen.huey@fwmedia.com)

**MANAGING EDITOR** Megan Fitzpatrick

x11348 ■ [megan.fitzpatrick@fwmedia.com](mailto:megan.fitzpatrick@fwmedia.com)

**ASSOCIATE EDITOR FOR THE WEB** Drew DePenning

x11008 ■ [drew.depenning@fwmedia.com](mailto:drew.depenning@fwmedia.com)

**PHOTOGRAPHER** Al Parrish

**CONTRIBUTING EDITORS**

Adam Cherubini, Bob Flexner, Troy Sexton

**F+W MEDIA, INC.**

**CHAIRMAN & CEO** David Nussbaum

**CFO** James Ogle

**PRESIDENT** Sara E. Domville

**SENIOR VP, MANUFACTURING & PRODUCTION** Phil Graham

**EXECUTIVE VP, eMEDIA** John Lerner

**VICE PRESIDENT IT, CIO** Mike Kuehn

**EVENTS DIRECTOR** Cory Smith

**CIRCULATION DIRECTOR** Linda Engel

**NEWSSTAND DIRECTOR** Susan Rose

**PRODUCTION COORDINATOR** Vicki Whitford

**ADVERTISING**

**ADVERTISING DIRECTOR**

Don Schroder

331 N. Arch St., Allentown, PA 18104

TEL. 610-821-4425; FAX 610-821-7884

[d.schroder@verizon.net](mailto:d.schroder@verizon.net)

**DISPLAY & CLASSIFIED ADVERTISING**

**SALES COORDINATOR**

Krista Morel

TEL. 513-531-2690 x11311

[krista.morel@fwmedia.com](mailto:krista.morel@fwmedia.com)

**SUBSCRIPTION SERVICES:** Subscription inquiries, orders and address changes can be made at [popularwoodworking.com](http://popularwoodworking.com) (click on “Customer Service”). Or by mail: *Popular Woodworking*, P.O. Box 420235, Palm Coast, FL 32142-0235. Or call 386-246-3369. Include your address with all inquiries. Allow 6 to 8 weeks for delivery.

**NEWSSTAND DISTRIBUTION:** Curtis Circulation Co., 730 River Road, New Milford, NJ 07646

**ATTENTION RETAILERS:** To carry *Popular Woodworking* in your store, call 800-894-4656 or write Magazine Retail Sales, P.O. Box 5014, Iola, WI 54945-5014.

**BACK ISSUES** are available. Call 800-258-0929 for pricing or visit [popularwoodworking.com](http://popularwoodworking.com). Send check or money order to: *Popular Woodworking* Back Issues, F+W Media Products, 700 E. State St., Iola, WI 54990. Please specify publication, month and year.

Copyright ©2009 by F+W Media, Inc. All rights reserved. *Popular Woodworking* is a registered trademark of F+W Media.



# The Felling Of 3 Giant Oaks

With 2009 at a close, I'm trying to take stock of all my gains and losses for the year—not the financial ones, but the more important personal ones.

This year we lost three men who changed the way I work wood: Sam Maloof, James Krenov and Jack Hill.

Of the three, I'd only met Sam Maloof, who died on May 21. In 2002, Maloof opened his home and shop to us, even though there was nothing that we could do to possibly make him more famous.

He introduced us to his shop workers and we examined one of Maloof's earliest pieces—a cabinet—that a customer had brought in for minor repairs. Maloof pointed out all the little mistakes he had made in the piece, both structurally and stylistically. (In other words, he acted just like any other woodworker.)

After a few hours, I became worried that we were taking up his whole day, so we kept trying to excuse ourselves.

"Nonsense," he said. "Let's go to lunch."

So we all piled into our cars and headed to a Mexican hole-in-the-wall.

"Get the chicken tacos," he advised. I obeyed. Over lunch we peppered him with questions about the craft, his work, his legacy and fellow woodworkers. He answered every question with a direct answer (a rarity in journalism)—especially the last question: "Can we pick up the check?"

"No," he replied. And sadly, I never got to return the favor.

In August, British chairmaker and

author Jack Hill died. Though American readers might not be familiar with Hill, his book "Jack Hill's Country Chair Making" (David & Charles) was an enormous influence on me when I began making chairs. I've always been fascinated by the vernacular chairs of the British Isles, and



Hill was one of the teachers who showed me that chairmaking is different than cabinet making. The rules of accuracy, for example, are completely different. And I struggled with that until Hill's book made it obvious.

And finally, on Sept. 9 we lost James Krenov, one of the most influential woodworking writers of this generation. His five

books, including "A Cabinetmaker's Notebook," changed the way that woodworkers think about the craft.

Few woodworking writers have ever managed to capture, bottle and distribute that impossibly compelling but difficult-to-explain relationship that all artisans have with their raw material. That was his gift to us all. So I'd like to end this entry with my favorite quote from Krenov:

"The understanding eye sees the maker's fingerprints. They are evident in every detail ... Leave Fingerprints."

Look carefully. Though we lost these three giants this year, we gained their fingerprints on our work, our tools and our lives. **PW**

PHOTO BY CHRISTOPHER SCHWARZ

## Customer Service

*How can I contact customer service with questions regarding my subscription, including a lost or damaged issue?*

Visit [popularwoodworking.com/customer-service](http://popularwoodworking.com/customer-service). Or write to *Popular Woodworking*, P.O. Box 420235, Palm Coast, FL 32142-0235. Or, if you prefer the telephone, call 386-246-3369 and a customer service representative will be happy to help you.

## *When does my subscription expire?*

The date of your subscription expiration appears on your magazine mailing label, above your name. The date indicates the last issue in your subscription.

## *Can I get back issues of Popular Woodworking?*

Back issues are available while supplies last. Visit [popularwoodworking.com/backissues](http://popularwoodworking.com/backissues). Or if you know the exact month and year of the issue you want, call our customer service department toll-free at 800-258-0929 to order.

## *What if I want more information about the projects and tools I read about in Popular Woodworking?*

For all editorial questions, please write to Popular Woodworking Editorial, 4700 E. Galbraith Road, Cincinnati, OH 45236. Or e-mail [popwood@fwmedia.com](mailto:popwood@fwmedia.com).

## *Does Popular Woodworking offer group discounts?*

Group discounts are available by special arrangement with the publisher. For more details, send an e-mail to [debbie.paoello@fwmedia.com](mailto:debbie.paoello@fwmedia.com) or call 513-531-2690 x11296.

## Our Privacy Promise to You

We make portions of our customer list available to carefully screened companies that offer products and services we believe you may enjoy. If you do not want to receive offers and/or information, please let us know by contacting us at:

List Manager, F+W Media, Inc.  
4700 E. Galbraith Road  
Cincinnati, OH 45236

## Safety Note

Safety is your responsibility. Manufacturers place safety devices on their equipment for a reason. In many photos you see in *Popular Woodworking*, these have been removed to provide clarity. In some cases we'll use an awkward body position so you can better see what's being demonstrated. Don't copy us. Think about each procedure you're going to perform beforehand.

# One Editor's Method to Sharpen a Scorp

I picked up a couple of scorps off eBay and they are in really good shape, other than the sharpening job from the previous owner. Do you have any pointers on how to sharpen a scorp? They will have to be ground before I try to put an edge on them. It appears the previous owner tried to sharpen them with a straight file, leaving numerous deep gouges that will have to be removed. What grinding angle is the best for scorps?

Joel Mahoney  
Belleville, Ontario

*I'm no scorp-sharpening expert. I sharpen mine and am very happy with the results on my chair seats, but I don't know if my technique is the best way or not.*

*I first grind the edge (when necessary) with a hand-held sanding drum chucked into a drill. Then to hone, I use adhesive-backed sandpaper that is stuck to 1"-diameter dowels. I start with #100 grit for shaping the bevel and work my way up to about #800 grit. I use long dowels (about 12" long) to keep my fingers away from the edge.*

*Other details: I clamp the scorp (sometimes called an "inshave") to hold it while I work, and I usually shoot for a 25° bevel on the tool. That seems a good compromise of durability vs. effort required to make the cut.*

— Christopher Schwarz, editor

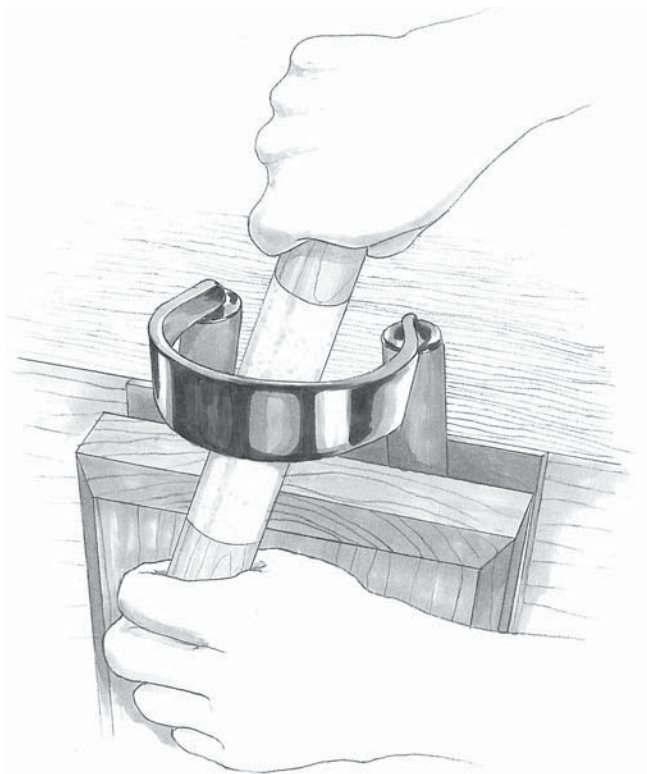

## A Sharp Reminder

I read with great interest "3 Ways to Make Raised Panels" in the August 2009 issue of *Popular Woodworking* (#177).

I recently raised some panels using the table saw method (about which Senior Editor Glen D. Huey wrote) and received a painful reminder of where to stand when ripping on the saw. The offcut (as shown on page 43 in step three) has sharp, pointed ends which can catch the blade and be kicked back toward the operator at high velocity. I was lucky and only received a bruise, but those sharp ends could have caused much greater injury. Lesson learned, never stand directly behind the blade.

Brad Patch  
Tucker, Georgia

## Admiring Trees in All Their Forms

Your April 2009 "Out on a Limb" (Issue #175) got my attention. It was thought-provoking, for sure.

I grew up in the nursery business and have always admired trees in all of their beauty and form. It is truly amazing what is out there if you really look at the trees and not the forest.

Growing trees for production, you get a feel for them in their youth, but I am always amazed and often in awe of the huge old specimens. The stories they could tell of what they have seen in their lives!

I guess this led to a natural appreciation for the wood that trees produce, which has brought me full-circle through the life of a tree.

I hope that this appreciation has led me to become a better woodworker.

Maybe, just maybe, I can do that grand old tree justice for the wood it has provided me to enjoy my hobby.

Hopefully others will help to continue to replenish this valuable resource.

Greg Salata  
Streator, Illinois

## Size Restrictions on Glass Doors?

I am planning to make glass fronts and doors for a wide showcase. When "up sized," I think the method used to construct the glass doors in the Barrister Bookcase project in the April 2007 issue (#161) will work for my purpose.

CONTINUED ON PAGE 14

ILLUSTRATION BY HAYES SHANESY

But how large can I make the glass doors? I would like them to be approximately 36" x 60". How thick or what "strength" should the glass be and what width should the rails and stiles be? I have a good supply of red oak on hand that will be used.

The display wall is 16' long and the 12" glass shelves are already installed. Would it be better to alternate fixed 36"-wide glass panels with the hinged 36"-wide glass doors?

Ken Vaughn  
Columbus, Ohio

*I think you'll be much better off if you reduce the width of the doors to 18". The size you propose is pushing the limits, especially if you use pocket screws (as we did on the Barrister Bookcase) instead of mortise-and-tenon joints on the door frames. Weight and leverage will work against you with wider doors. If you make the doors narrower, you could size the stiles between 1 1/2" and 2" wide. Regular 1/8"-thick window glass should be fine in this application.*

— Robert W. Lang, senior editor

### Bench Slat Replacement Tips

I need to fix two red oak indoor benches. Both benches are missing slats in the backs. The flat slats are in mortises in both the upper and lower rails. Without breaking loose the rails (which are also mortises and tenon) is there a way I can insert new back slats?

Paul Yanney  
via e-mail

*Without seeing a photo of the bench, it is hard to come up with a number of options. But one way to accomplish this task without re-working the intact mortise and tenons (if there is no shoulder on the tenons) is to deepen the mortise in the upper rail and slide the slat farther up into that rail—at least enough to allow the slat to fit between the rails. Then align the slat bottom with the mortise in the lower rail and pull the piece downward into the mortise.*

*If there is a shoulder to work with, that option is null. In that case, you would need to disassemble the mortise-and-tenon joint of one rail and fit any full-size, one-piece replacement slats to the bench.*

*Another option, although aesthetically an issue, is to create new slats that can be joined after assembly. Cut a half-lap or scarf joint to meet in the center of a slat, push the tenoned ends into*

*position, then affix the half-lap area with glue. However, this option may be more work than reworking one mortise and tenon.*

— Glen D. Huey, senior editor

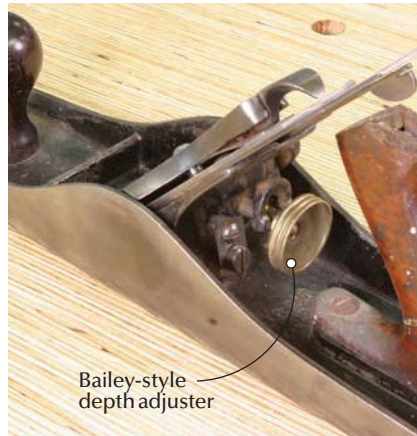

### History of Bailey Depth Adjuster

I was very interested to see your short review of the new premium Stanley No. 4 bench plane in the October 2009 issue of *Popular Woodworking* (#178). It was especially good to see the plane discussed on its own merits, rather than being compared to other planes not included in the test.

Just in the interest of historical accuracy, I want to call your attention to the mentions, once in the text and once in a picture caption, suggesting that Stanley invented the Bailey depth-adjuster mechanism for bench planes. As the name suggests, that was an innovation of Leonard Bailey, patented by him on August 6, 1867 (patent #67,398, if anyone's checking). Two years later, in 1869, Bailey sold the license to use his plane patents to Stanley Rule and Level Co., and in 1870 Stanley introduced its new line of planes, based on Bailey's designs, including the depth adjuster. Some years later, in 1902, in recognition of Bailey's contributions, Stanley began to cast "BAILEY" into the bodies of its iron planes.

Tom Holloway  
Vacaville, California

### Comments and Concerns with Benchtop Table Saw Review

In the October 2009 benchtop table saw review (issue #178), you give high praise to the twist-lock insert retainer used by DeWalt. I see that this would make replace-

ment inserts more expensive, and home-made ones impossible. If DeWalt would have mounted the twist lock in the table instead of in the insert, at least making your own inserts would probably not be an issue.

I make mine from MDF for about 50 cents each, and varnish and wax them. I began making them from HDPE plastic, as recommended in several publications, but found that the material was not flat at all.

Also, the table on page 37 gives a measurement of "front edge to insert." Wouldn't this be more useful if you measured "front edge to blade" and took the length of the insert out of the picture?

Alan Wesley  
via e-mail

*I agree that making a replacement insert for the DeWalt would be more difficult if you attempted to have the new insert lock in the same manner. But if you made a replacement that didn't lock, you would be in the same position as if you made a new insert for any of the other models.*

*As for the distance to the blade versus the insert, I agree with you and was going to measure that way when I realized that the blade height would affect the measurement—the higher the blade, the less the distance. In the end, I felt a less-variable number would be more useful information. PW*

— Glen D. Huey, senior editor

### Question? Comment? We want to hear from you.

*Popular Woodworking* welcomes comments from readers about the magazine or woodworking in general, as well as questions on all areas of woodworking. We are more than happy to share our woodworking experience with you by answering your questions or adding some clarity to whatever aspect of the craft you are unsure about, and if you have a complaint, we want to address it whenever possible.

Though we receive a good deal of mail, we try to respond to all correspondence in a prompt manner. Published correspondence may be edited for length or style. All correspondence becomes the property of *Popular Woodworking*.

Send your questions and comments via e-mail to [popwood@fwmedia.com](mailto:popwood@fwmedia.com), or by mail to:

Letters  
Popular Woodworking  
4700 E. Galbraith Road  
Cincinnati, OH 45236



THE WINNER:

# Safer Sheet-goods Sawing

I use a portable circular saw to break down plywood and other sheet goods into manageable pieces before bringing them to the table saw for final sizing. I prefer to do the job on sawhorses rather than crouching on the floor. Unfortunately, you normally need three or four horses to provide enough support to prevent cutoffs from binding the saw blade and crashing to the floor at the end of the cut.

My trick is to use a full sheet of 2"-thick rigid foam insulation (available at home-supply stores) as a cutting platform straddling two horses. I lay my plywood on top, and clamp it and the insulation board to the sawhorses. I adjust my saw blade depth to

cut no more than 1/8" or so into the insulation board (always cutting into the same face to preserve strength.) I can now make my cuts safely and securely with all pieces fully supported at the end of the cut. If necessary, I can clamp workpieces or straightedge guides anywhere I like by removing the jaw from a clamp, poking the bar through the foam board, then reattaching the jaw. When I'm done cutting, the lightweight insulation board stores perfectly with my other sheet goods.

— David Peterson, Hillsboro, Oregon

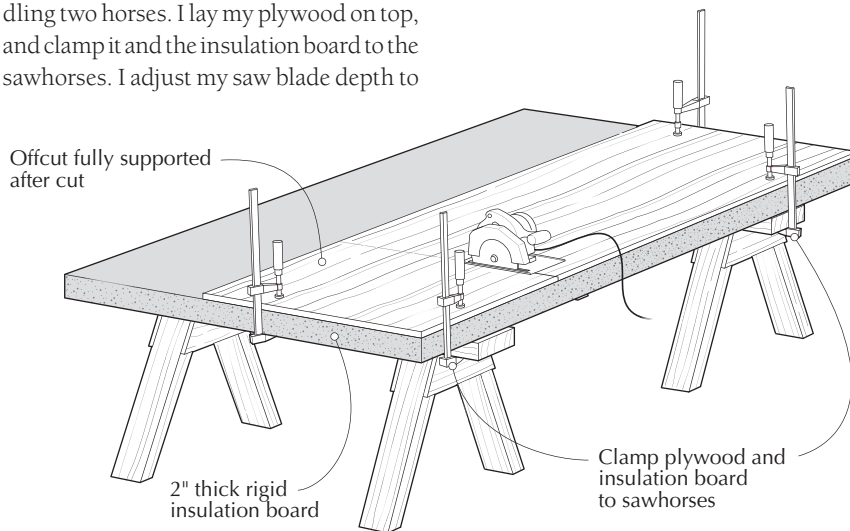

## Vise in a Vise

I don't use my machinist's vise often enough to dedicate any of my limited bench space to it. Instead, I keep it tucked under a nearby cabinet for occasional use. I bolted the vise to a board that has a heavy cleat glued to its front edge, which allows me to clamp the whole setup in my bench vise. It's a quick and easy change-over that provides for secure mounting in use.

— Paul Anthony, PW Contributor

CONTINUED ON PAGE 18

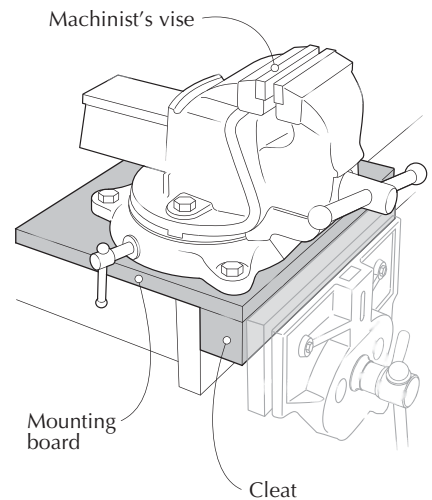

## Cash and prizes for your tricks and tips!

Each issue we publish useful woodworking tips from our readers. Next issue's winner receives a \$250 gift certificate from Lee Valley Tools, good for any item in the catalog or on the web site ([leevalley.com](http://leevalley.com)). (The tools pictured at right are for illustration only, and are not part of the prize.)

Runners-up each receive a check for \$50 to \$100. When submitting a trick (either by mail or e-mail) you must include your complete mailing address and a daytime phone number. If your trick is selected for publication, an editor will need to contact you. All entries become the property of *Popular Woodworking*. You can send your trick by e-mail to [popwoodtricks@fwmedia.com](mailto:popwoodtricks@fwmedia.com), or mail it to Tricks of the Trade, *Popular Woodworking*, 4700 E. Galbraith Road, Cincinnati, OH 45236.



## Easy-lift Bench Dogs

I really like my round Veritas bench dogs because they're so versatile and easy to install. The only problem I have with them is raising the less accessible ones when they're tucked down flush in their holes. My bench is against a wall, which makes it difficult to push the rear-most dogs up from underneath. To solve the problem, I drill a shallow hole into the flat face of a hard-to-reach dog. That allows me to quickly and easily lever it upward by inserting a small screwdriver or awl into the hole. This trick would also be useful for benches with cabinets installed underneath.

— Alejandro Balbis, Longueuil, Quebec

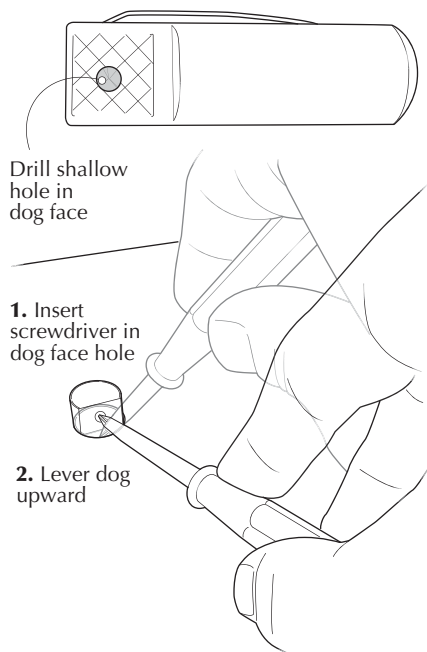

## There's the Rub

When making crosscut sleds and other runner-guided jigs for woodworking machines, there's always the matter of fine-tuning the fit of the runners so they glide smoothly but without side-to-side play. After sizing the runners to the table slots, then attaching the jig to them, I rub a wide-point carpenter's pencil aggressively across the sides of the slots. Pushing the jig back and forth then transfers the graphite to the runners anywhere they're binding in their slots, which makes targeted trimming a breeze.

— Paul Anthony, PW Contributor

## Edge-joining Thin Boards

Thin boards glued edge to edge have a tendency to spring out of place when pressure is applied to the bar clamps. A simple solution is to use short, notched caul clamps at the ends of the joints. The cauls keep the boards aligned, while the notch prevents glue squeeze-out from bonding the cauls to your boards.

When gluing up, rest your boards on  $\frac{3}{4}$ "-thick scrap to allow access for the caul clamp heads. Apply just enough bar clamp pressure to snug up the edges of the boards, then attach the cauls and clamp them lightly into place. You can now apply the final clamp pressure to pull the boards together without them buckling on you.

— Rob Porcaro, Medfield, Massachusetts

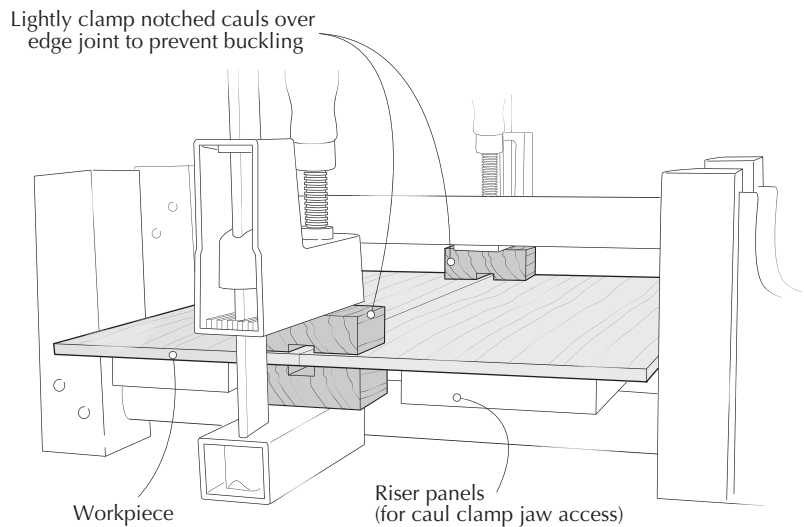

## Quick Panel-finishing Setup

When making frame-and-panel doors, my panels are finished before installing them into their frames. The fact that the edges will be tucked into the frames allows for a quick, easy setup that permits finishing both faces right away instead of waiting for one face to dry before flipping the panel over to finish the other side.

Insert two widely spaced push pins into one end of the panel, and one into the center of the opposite end as shown.

Rest the push pins on the edges of a pair of 2x4s, and apply finish to the first face of the panel. Afterward, grab the pair of pins at one end, flip the panel over, rotating it on the single pin at the opposite end, and bring it to rest again on the 2x4. Now you can finish the opposite side. The holes from the pins won't show once the panels are installed. The same setup can be used to finish any sort of tall door on which the top and bottom edge won't ever be seen. To support heavier pieces, use brads or nails. **PW**

— Mark Freestone, Austin, Texas

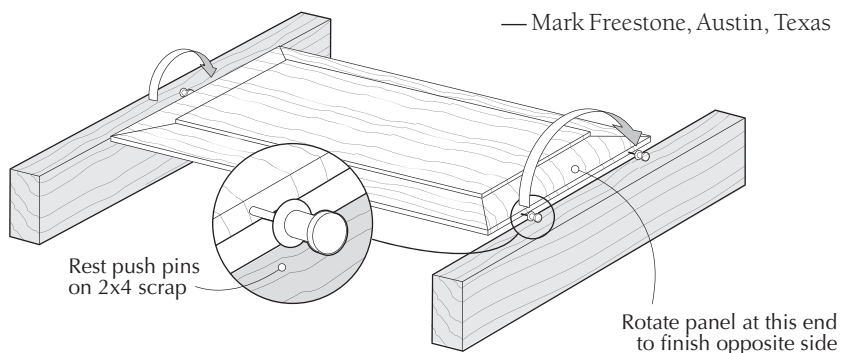

# Hidden in Plain Sight

Lessons learned from examining a Pennsylvania Spice Chest.

On a recent tour of Pennsbury Manor, the reconstructed home of William Penn in Bucks County, Pa., where I volunteer some weekends each year, I noticed a small “spice chest” atop a larger case piece in a dark corner. The Pennsylvania black walnut, though lightened after nearly 300 years, did nothing to proclaim the presence of the tiny box. Roughly 17" square and possessing restrained mouldings and bun feet, even its silhouette was uninteresting. Its flat door revealed only upon closer examination a touch of figured grain and a fancy keyhole escutcheon. The door was closed, concealing the only interesting part of the chest – the woodwork inside.

These chests were typically fitted out with myriad drawers to store precious items. It's true that spices were expensive then, but few of these boxes were actually used to store spices. Rather, they were used to store valuables such as coins, jewels, important papers, possibly keys and other expensive household items.

Pennsbury Manor's museum curator, Kim McCarty, probably positioned the box purposely to keep it out of the sun's damaging rays. But she may have also suspected that a “hidden in plain sight” location would have been chosen for boxes like this one 300 years ago.

Imagine yourself living in that time. What would you do with earnings from the sale of a prized hog, for example? Would you hide your money under your mattress? For most of us, our mattresses and our bedrooms are private. But Colonial homes had few or no private spaces. Folks wealthy enough to have something to hide invariably had household servants. Even when one's own servants could be trusted, homes were often awash with relatives, neighbors, custom-



**Hidden treasure.** A rare look inside Pennsbury Manor's early 18th-century Pennsylvania spice chest reveals its array of tiny drawers. Originally designed to hide precious objects, it still contains many hidden treasures for those of us interested in history and woodworking.

ers or merchants, and very possibly their servants. A coin hidden in a secret place could be discovered and pilfered without detection. A spice chest filled with valuables, “hidden in plain sight,” would be difficult to shoplift. And that's the sense I get from objects such as these. Colonial homes might seem to us more like stores at the mall than quaint private residences. The spice box furniture form is yet one more reminder that our ancestors lived in a world we probably wouldn't recognize.

But there's more hidden in this little chest than a history lesson. The original was made of three different species of wood. This is a common characteristic of Colonial-era furniture. The door, sides, top, mouldings and feet are all black walnut. The bottom, drawer bottoms, back and drawer dividers are all yellow pine (which grew in the Delaware Valley at that time). The thin drawer sides are all white oak. It could have been the case that these woods were chosen for

their mechanical properties: Walnut for its color and stability, oak for its strength and wear characteristics, and pine for its low cost, perhaps? Could be. But a closer examination revealed interesting similarities in the grain orientation of the different species.



**Mixed materials.** This chest's drawers are constructed of 1/2" walnut drawer fronts, 1/4" riven white oak sides and 1/4" sawn yellow pine bottoms. Was this choice of materials based on utility, availability, or ease of stock preparation?

The walnut was all flat-sawn. The oak was all perfectly quartered, suggesting it was riven (though no rive marks were evident). The pine was sawn, though the pieces chosen were close to the tree's heart. I wondered whether this little chest wasn't a record of different stock preparation techniques taking place in cabinet shops of this era.

### Sawn Lumber

The 4/4 walnut used for the carcass was probably commercially sawn. Based on the rings, I estimated the minimum diameter of the log at 18". I think that's really too wide to handle without a pit saw, the long two-man saw used to convert logs into lumber back then. Some cabinet shops did indeed have pit saws, but they were then indistinguishable from commercial (professional) sawyers. Other cabinetmakers purchased their lumber in the thicknesses required, much as we do today. We can assume the lion's share of that lumber was 4/4, much as it is today.



**Thicknessing thoughts.** I suspect 18th-century cabinetmakers did as little thickness planing as possible. I don't see many different thicknesses of stock used on period furniture. When it was necessary, a jack plane like this one was used in Anglo-American shops (scrub planes are a Continental European tradition). This plane is throwing .020-.040" shavings (note: neatly in a row at that!). They are only an inch or so wide because the blade is curved. Note my relaxed and unorthodox grip on the plane. I prefer wooden planes because they are light, slide easily and they offer many different ways to hold them. With no secondary support for the board, I'm leaning over my bench, controlling the stock under my plane. I don't want to kid anybody; this can be a lot of work. Judging from my observations of period furniture and this piece in particular, I think it was work that guys in the 18th century tried to avoid. You should too.

### Thickness Planing

The drawer fronts on this piece are all 1/2" thick. It's possible sawyers prepared 1/2" stock for the cabinetmaker. But in those days, sawyers charged by the foot, making a board of 1/2" stock essentially the same

price as 4/4 or 8/4. The price for the lumber and the sawing were separate. The individual pieces selected for the drawer fronts seem to have been chosen for their interesting grain. It doesn't appear any attempt was made to match one drawer front to the others. In

## Smoothing Figured Wood

This little spice chest exhibited nearly flawless surfaces and on curled grain at that. And though this may come as no surprise to Clark & Williams' customers, I had little trouble smoothing my knotty



walnut with a simple wooden smoothing plane (below left). There are a few things you can try to get the most out of your smoother, be it wood or metal:

First, make sure your blade is super sharp. I sharpened my blade before and during this smoothing session. Next, I find that downward force really helps. Some advocate for heavy planes, but no plane is this heavy. A low bench is key to producing this kind of force without feeling like your personal trainer just left for the day. And last, go slowly. Don't be in a hurry to remove wood. A light-set blade and slow movements help.

As a last resort, you can always scrape (below center). The secret to successful scraping is learning to sharpen a scraper

with a smooth edge. If the edge is jagged, it will remove wood quickly, but leave a scored surface behind. Editor Christopher Schwarz produced a good video on the subject. It's available from Lie-Nielsen Toolworks ([lie-nielsen.com](http://lie-nielsen.com)).

But wait there's more! The cabinetmakers in Colonial Williamsburg's Anthony Hay shop have found success using their toothy planes to level difficult surfaces, finishing with a scraper. Why anyone would use sandpaper on a flat surface when they have these fine tools escapes me. Toothy planes can be used in any direction. I moved my left hand back while I was doing this just to give you a better look at the plane (below right). — AC



fact, I get the distinct impression the builder was seeking a variation of color, perhaps to help distinguish the different drawers. This appears in evidence in the Edward Evans “Scrutore” (on display in Colonial Williamsburg’s Wallace Dewitt gallery). So the sense I get is that the cabinetmaker foraged for scraps of different colors and planed them to 1/2".

Cabinetmakers could change the thickness of their stock by planing it down. This can be a time-consuming process, but it makes sense when a small amount of wood is required (as on these drawer fronts). Anglo-American craftsmen from this period began the process with a jack or fore plane, a medium-length plane. If a high degree of flatness was required, they might have followed the jack plane with their longer “try” planes. A smooth plane would have typically finished the exterior.

### Resawing

It was possible for cabinetmakers to resaw lumber in their own shops. Long frame saws, resembling miniature pit saws, were used to resaw narrow stock, veneer or small amounts of wide stock in European shops throughout

the 18th century. I’ve not seen evidence of these saws in 18th-century Philadelphia shops, but I wouldn’t be surprised if they had them. The same cuts can be accomplished with only slightly more difficulty by using a standard rip saw (saw the corners out). On this spice chest, the pine drawer bottoms would have been significantly easier to resaw than the white oak used for the drawer sides.

My interpretation is that where thin stock was needed in widths inconvenient for riving, an easy-to-saw wood (such as pine) was chosen. My feeling is that the thin stock used for drawer construction throughout the period presented Colonial-era woodworkers with a significant challenge. What began as riven oak sides and sawn pine bottoms, ended with riven white cedar drawer sides and bottoms. Virtually every other piece of wood in a case piece (of any size) was 4/4, mouldings excepted. I think this speaks to the difficulty of resawing and thickness planing.

### Riving

Colonial American furniture often shows evidence of riven (split) lumber. This fact

seems to be lost on those concerned about the cross-grain joinery and wood stability. Riven wood is the most dimensionally stable cut of wood, widthwise and lengthwise, varying primarily in thickness (percentage-wise). In the 18th century, riving was also the fastest way to process stock.

We usually think about riving as old-fashioned in the 18th century, or reserved for “country” craftsmen. As more people like us examine period furniture, I suspect we’ll see increasing evidence of its use on a wide range for products. It may seem a little silly or uncontrollable, but it really is a practical way to produce superior furniture parts.

### Conclusion

I think we can look at old furniture as archeological finds, analyzing the remains for clues about lost civilizations. In this case, I looked not only at surfaces for clues about stock preparation techniques, but also at thicknesses and ring orientations to try to piece together a narrative of what might have been happening in this particular cabinet shop. Here’s the story I think I’m hearing:

This cabinetmaker had 4/4 walnut. He was able to use the narrower stock, sawn closer to the sapwood, for the carcass. For the door and drawer fronts, he foraged for figured material. What he found, he planed to 1/2" thickness for drawer fronts. They were scraps and it wasn’t a lot of material, so planing was the easiest method to prepare this stock.

For the narrow drawer sides, riving was fastest. Oak rives best and was plentiful, so oak was used. Sawn lumber would have been a more expensive choice with quartersawn material particularly expensive.

For drawer bottoms he needed wide, thin pieces. Splitting out wide, thin pieces is much harder than splitting narrow stock. So he decided to saw these. He could have chosen oak to match his drawer sides. But pine was easier to saw than oak. For the interior dividers, 6" to 8" wide material was required. Six inches is really no problem for an ordinary handsaw. But 8"-wide material is pushing it. My guess is he used some kind of frame saw like mine. But don’t let me put you off resawing by hand. I’ve resawed 12" material with my handsaw. No matter how hard it seems, it’s still easier and faster than planing it down by hand.



**Not so hard.** Despite the look of despair on my face, this saw is pretty easy to use. The problem I’ve had is controlling it! The tool is a reproduction of one depicted by Roubo dating from the 1760s. Its blade is 4' long and features two teeth per inch. It’s difficult to start but cuts aggressively once the kerf is established.



**Splitting.** *Splitting thin pieces is not difficult and you don't need a lot of specialty equipment. Here I'm using a lightweight (read cheap) basket froe. I smacked it into the end grain of this oak using a homemade dogwood root cudgel. Though a riving brake would make this job safer and easier, steadying the log with your feet works also. Just try not to get a snag in your favorite baby blue stockings!*

I've talked in the past about the speed of 18th-century craft work. I based that on documentary evidence. Here, we can see what I think is physical evidence of 18th-century craftsmen making material choices to increase their efficiency. I find this interesting for a couple reasons:

After having described (once again) that our ancestors were essentially nothing like us, here is an example of how we are alike: impatient, looking to cut corners and maybe not as concerned as we should be about wear, repair, and expansion and contraction. The other reason I find this interesting is that it elucidates the intentions of period artisans. Fans of period work (I mean me) can sometimes over-analyze what we see. I think it's true that quartersawn – or even better, riven stock – makes a better drawer. The question is, were they intending to make a better drawer or just a faster one? The answer may be hidden right before our eyes. **PW**

---

*Visit Adam's blog at [artsandmysteries.com](http://artsandmysteries.com) for more discussion of traditional woodworking techniques.*

# Recycling Station

Handy and handsome, this piece helps you keep refuse neatly separated.

In some locations these days, recycling is mandatory; fines can result if recyclable materials are thrown out with your garbage. But at my local home center, there are few aesthetically pleasing options for sorting and storing recyclables until the weekly collection.

This project is sized to fit the cheerful green “party tubs” I found at the home center (just \$8 each), which are 15½" deep, 21¼" wide and 11" high. Purchase your bins, buckets or baskets before buying your lumber, as you may need to adjust your sizes to fit whatever receptacles you plan to use.

## Overcome a Lumber Conundrum

If your bin sizes match mine, you'll need 60" or so of 18"-wide lumber for the sides, and 46" or so of 17¾"-wide lumber for the shelf and bottom (I've added a bit to the actual total necessary lengths to allow for saw kerfs). And you'll also need a ¾" x 18¼" x 25" piece for the top. You can't often purchase 18" or 18¼"-wide material off the rack, so you're going to have to glue up panels, or cut down pre-made panels. The less-expensive option (by far) is to glue up your own panels, at which point it's simpler to crosscut all your pieces to rough length first, then glue up each panel individually.

So, if you're buying off the rack at the home center, you may think that a 1x10 glued to a 1x8 will get you your 18" – but it won't. Remember that dimensional lumber is sold in nominal sizes, and widths greater than 6" are actually ¾" less than the nominal width (and ¼" less in thickness). So a 1x8 is actually ¾" x 7¼". It's confusing, but it's the industry standard. So, you'll be looking for nice, straight, flat 1x10s, which



**Keep it neat.** This handy piece helps you separate and store recyclable items.

will glue up into panels that are ¾" x 18½". From those, you can get all your panels.

After the glue dries, rip them to the necessary widths with a jigsaw or circular saw, guided by a straightedge. Then cut the sides, shelf and bottom to final length – hold off on cutting the top yet, as you may wish to adjust the overhang after the base is together.

## Pocket-screw Joinery

I chose clean, straight lines for the foot cutouts at the bottom to give the piece a contemporary look; refer to the illustrations for the layout.

The shelf and bottom are drilled for eight pocket screws, four at each end, spaced approximately 1½" and 5" in from each edge – avoid drilling directly on your glue line.

Now lay out the bottom and shelf locations, marking the top and bottom of each on both side pieces.

Next, clamp a wide, straight cutoff at the top edge of the shelf location. With the

shelf pressed against the stop block and aligned at the front edge of the sides, sink the screw on one edge, then the other. These are wide pieces and you may have some cupping issues, but you should be able to pull the cup out as you screw the shelf in place, as long as you push each end tight to the stop block. Now sink the two middle screws. Place the second side flat on your work surface, align the shelf and bottom, and repeat.

## Top and Apron

Decide on the overhang for your top. I opted for a ¼" on the front to line up with the ¼"-thick screen moulding, and ½" on either side. Cut the top to final width, then align it to the case (the back edge is aligned with the back edge of the side pieces), mark a line from front to back ½" in from each end, and drill four or five holes for nails, then nail the top on. Use a nailset to sink the nailheads below the surface, then fill the holes with wood filler or spackle.



**Mark, then cut.** After marking out the shape of the feet on one side piece, clamp the two sides together, make a relief cut or two, then cut away the waste. I use my thumb as a guide, but you could clamp a straightedge in place to guide your cuts if you're aiming for perfection.

Your apron is, in theory, 3" wide x 22½" – but things can change a bit during construction, so carefully measure from the inside face of each side to get the spot-on measurement, then cut it to length. The cut-out is the same as on the side pieces and the apron is attached with two pocket screws on either end; pull it tight to the bottom as you sink the screws.

Grab an offcut that's about 1" wide, and measure and fit it ¼" in from the back edge of the top, aligned with the back edge of the sides, and nail it in place from underneath. You'll attach the back panel to this top rail, flush with the underside of the top.

### The Back Panel

For the back panel, I bought an inexpensive piece of ¼" x 3' x 3' piece of pre-finished beadboard hardboard, and for visual interest, ran it horizontally across the back. This piece must be cut carefully; it should fit tightly from side to side and top to bottom. Use a straightedge to guide your jigsaw or circular saw, use a sharp blade and cut



**Plane to fit.** If your apron and shelf aren't perfectly flush, a few passes with a block plane will even things up.

slowly. Wait to nail in the back until after you've painted.

### The Finish

I applied two coats of semi-gloss latex paint to the carcass, back panel and screen moulding. After the paint dried, I installed the screen moulding around the edge of the bottom, cutting it at 45° angles at the miter saw. Align the moulding across the front, then mark the cuts directly from the carcass. Nail the moulding to the front.

Now head back to the miter saw and cut a 45° angle for the first side piece, leaving it over-long. Use a large adjustable square



**Square it up.** Hang an adjustable square from the front edge of the carcass down the side to ensure you get the moulding installed at a perfect 90°.

(as shown above) to ensure you have the moulding aligned properly. Fit the miter snug to the front moulding, and mark the back edge. Do the same with the other side moulding, then make 90° cuts at the back ends. If your piece is unpainted, apply glue to only the front 3" or so of the moulding, then nail it in place on each side. You have cross-grain construction here, so the glue will hold the moulding to the front edge, and any movement will occur toward the back, where the nails will move with the wood. (If it's painted, just glue the miters.)

Slip the backboard in place and nail it to the rail, shelf and bottom.

Now you're ready to break out a fresh case of Diet Coke. **PW**

*Megan is the managing editor of this magazine. She can be reached at [megan.fitzpatrick@fwmedia.com](mailto:megan.fitzpatrick@fwmedia.com) or 513-531-2690 x11348.*

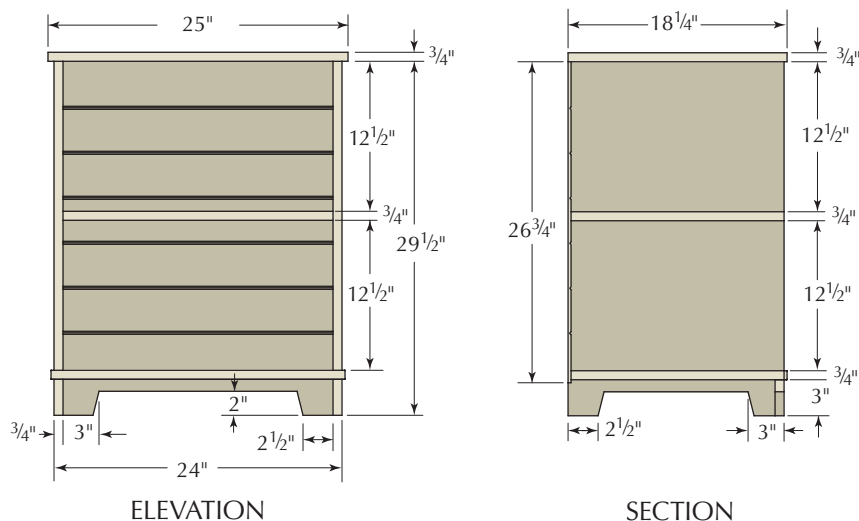

### Recycling Station

NO.	ITEM	DIMENSIONS (INCHES)			MATERIAL	COMMENTS
		T	W	L		
□ 2	Sides	3/4	18	29 1/2	Poplar	
□ 1	Shelf	3/4	17 3/4	22 1/2	Poplar	
□ 1	Bottom	3/4	17 3/4	22 1/2	Poplar	
□ 1	Top	3/4	18 1/4	25	Poplar	
□ 1	Apron	3/4	3	22 1/2	Poplar	
□ 1	Screen moulding	1/4	3/4	72	Pine	Wrap around sides
□ 1	Top rail	3/4	1	22 1/2	Poplar	
□ 1	Backboard	1/4	22 1/2	26	Hardboard	

### About This Column

Our "I Can Do That" column features projects that can be completed by any woodworker with a modest (but decent) kit of tools in less than two days of shop time, and using raw materials that are available at any home center. We offer a free online manual in PDF format that explains all the tools and shows you how to perform the basic operations in a step-by-step format. You'll learn to rip with a jigsaw, crosscut with a miter saw



and drill straight with the help of our manual.

Visit [ICanDoThatExtras.com](http://ICanDoThatExtras.com) to download the free manual.



# Get the Most From Your Router

These tips and tricks will take you a long way toward success.

**T**he router is, simply put, a multi-tasking workhorse in the woodshop. But you would be surprised by how many folks don't get the most out of their router experience. After all, this hand-held powerhouse has the potential to create, and an equal and opposing power to destroy. While the concept seems simple—a metal bit spins in circles as you drag the unit along a piece of wood—it can be harder than one might think to achieve perfect and consistent results.

I vividly remember my first experience with a router. The shellac on my woodworking wings was still wet and I decided it was time to get serious about edge profiles and joinery. I dropped some hard-earned cash on the same router I saw David Marks use in his DIY Network show, "Woodworks"—the Dewalt DW621.

I had visions in my head of graceful roundovers, crisp chamfers and perfectly cut mortises. Unfortunately, the reality was a little less magnificent. Between the tear-out, the burn marks and the occasional piece of airborne wood, I was feeling discouraged.

Taking a step backward I decided to hit the books and reinforce the fundamentals of good routing. Armed with that knowledge, I returned to the shop and began to achieve the results I had originally hoped for. Since then, the router has become one of the most useful and versatile tools in my arsenal.

Over the years I've learned numerous



**Bit arsenal.** If you do a lot of routing, you'll surely build up a large collection of bits in a short time. Keep them neatly organized and clean, and they'll always be ready for the routing job at hand.

tips, tricks and insights that I wish I was aware of when I first fired up that router. Here are some of my favorites.

## What Bits to Buy?

Buying a set of router bits can be incredibly daunting for an experienced wood jockey, let alone a noob! Woodworkers everywhere ask themselves, "Should I buy a set or individual bits?" and "Why does one 12-piece set cost \$30 while another set costs \$200?" and "What about those 100-piece sets with the too-good-to-be-true prices?" Well forgive me for generalizing folks, but when it comes to router bits, you get what you pay for.

An inexpensive bit made with cheap steel just can't compete with a high-quality carbide bit in terms of balance and longevity. But let's not throw out the good wood with the sawdust! Bargain bits do have their place. The real dilemma is knowing which bits you'll use the most in your work.

Unfortunately this is something you don't always know ahead of time. My recommendation is to buy an inexpensive 12- or 20-piece set, use it for a few months then see for yourself which bits get the most action. Now you have a much better idea of which bits are worth buying from a better-quality manufacturer.

## Online EXTRAS

To watch a video of The Wood Whisperer as he demonstrates ways to create burn-free routed edges and explains how flush-trim bits improve your work, go to:

[popularwoodworking.com/dec09](http://popularwoodworking.com/dec09)

Another great thing about this tactic is that you now have a nice assortment of bits at your disposal. The day will come when you need a special bit for a special situation, and you'll be glad you have that 20-piece set sitting there ready and waiting.

### The Flush-trim Bit

If there is one bit that provided that "Aha!" moment for me, it was the flush-trim bit. If you aren't familiar, a flush-trim bit is nothing more than a straight bit with a mounted bearing that's the same diameter as the bit.

If you attach a pattern to a workpiece, you can easily create an exact copy of the pattern's shape within seconds. This helps us produce identical table legs, flushes up overhanging veneer after glue-up, trims edge banding flush with the surface and can even help batch out those fancy picture frames in time for the holidays!

One other use for a flush-trim bit that we can't overlook is joinery. With the help of a simple shop-made template, you can produce perfect mortises all day long.

### Don't Bite Off More Than You Can Chew

When you use a tool for the first time, do you generally go slow or do you just ram it in there? Seems like the answer should be obvious, but you'd be surprised how many people I've seen slam a router into wood like there's a prize waiting at the board's center.

Inevitably the router takes off on its own and the wide-eyed student is left holding on for dear life. Don't let this happen to you. When routing a workpiece, think about how you can make the operation safer by taking multiple passes. It does create a little more wear and tear on your bit but the benefit comes in the form of a crisp, clean, tear-out-free cut and the special added bonus of keeping all your fingers.

### Spiral Bits

Spiral bits are a cool variation of the straight bit and they excel at creating mortises. The curved cutting surface produces a clean cut in much the same way a bench plane cuts more easily if skewed. Because of the spiral design, these bits are available in two styles: up-spiral and down-spiral.

An up-spiral bit is likely to stay cooler as it naturally brings the sawdust up and out of the mortise. Less debris means less friction



**Flush trimming.** All of these bits are flush-trimming bits. Notice that you can get bits with the bearing on the top or bottom, in different sizes and with different shank diameters. What you buy depends on your router and routing needs.

and less friction means a cooler bit.

The one negative side effect of the up-spiral is that it has a tendency to tear out the fibers near the top of the mortise. This isn't a big deal if your tenon has a decent shoulder on it, but if you are creating a through-mortise, you'll want the cleanest edge possible. That's where the down-spiral bit comes into play. So most of the time, up-spiral is my bit of choice, and I use down-spiral only where the edge will be visible or if the wood is especially prone to tear-out.

### More Router Tips

Here is a shotgun blast of handy tips:

If you've the option, buy 1/2"-shank bits. They are less likely than 1/4"-shank bits to vibrate and should produce cleaner cuts.

Stay away from high-speed steel bits. Carbide stays sharp significantly longer.

Keep the router moving. It's OK to go slow, but try not to stay in one place for too long. You'll burn the heck out of your wood and the excessive heat will dull your bit before you know it.

A dirty bit feels like a dull bit. Keep your bits clean by scrubbing them with a toothbrush and a mild cleaning solution such as Simple Green or even a little soap and water. Dry the bits thoroughly afterward (I use a blow dryer).

If you can, try to buy a router with some sort of dust collection. Keeping the chips out of the path of the bit yields a cleaner cut. And as always, less dust in the air means less dust in our lungs.

As handy as these tips are, they only tell a small part of the router story. In fact, I consider these to be "gap filler" tips. So it's a good idea to purchase a good book, or perhaps a DVD, to really get into the meat



**Keep it clean.** If your bit isn't cutting well, it might not be dull, just dirty. Clean your bits after use with a toothbrush and a mild cleaning solution.

of the subject. Although there is really no substitute for hands-on practice, I find that a strong background knowledge makes the learning curve easier. Before you know it, safe, effective and creative routing will just be a routine part of your woodworking bag of tricks while wood missiles, tear-out and burn marks will be a thing of the past. **PW**

Marc is a professional woodworker as well as the creator and host of *The Wood Whisperer* ([thewoodwhisperer.com](http://thewoodwhisperer.com)). *The Wood Whisperer* (an instructional Internet woodworking show) represents Marc's three passions: woodworking, technology and education.

### About This Column

Our "Wood Whisperer" column features woodworking thoughts and ideas, along with shop techniques from Marc Spagnuolo. Most columns have a corresponding video related to the techniques or views expressed in the column available at [popularwoodworking.com/video](http://popularwoodworking.com/video).



# SawStop's 'Tweener' Saw

SawStop introduces its Professional Cabinet Saw to round out your table saw choices.

When the SawStop Professional Cabinet Saw (PCS) arrived at our shop we uncrated the tool to find that the saw is shipped on its side (other manufacturers ship their saws standing upright). Tipping the saw reduces the potential for damage during shipment. That's innovative "in the box" thinking.

We put the PCS through the normal setup checks during assembly. Even though I didn't need to adjust the saw's blade/miter slot setting (it was only out .001"), I did so anyway to check the process. It's easy to adjust should you need to do so.

In typical SawStop fashion, directions are clear and concise and all the nuts and bolts are packaged in clearly defined groupings to maximize an efficient assembly.

A small tweak was necessary before we pushed wood into the blade. The fence on the PCS required a bit of adjustment to flush a .004" dip out of the center, right at the blade. SawStop has made this adjustment easy with slots on the bottom of the fence and an included hex driver.

Of course, the new SawStop saw has the patented brake system for which the company has become known. That's a given. However, if you compare the PCS to SawStop's Industrial Cabinet Saw (ICS), there are major differences, especially if you examine the weight of the saws. Added weight helps to smooth cutting operations.

You'll find the PCS (with the 36" T-Glide fence system) is about 200 pounds lighter than a comparably equipped ICS which



Professional Cabinet Saw

SawStop ■ 866-729-7867  
or [sawstop.com](http://sawstop.com)

**Street price**

- Saw with 32" Fence System, \$2,899
- Saw with 52" Fence System, \$2,999

For more information, go to [pwfreeinfo.com](http://pwfreeinfo.com).

sells for \$3,909. According to the company, that weight differential is the result of a few design changes, including trunnion size and design.

The trunnion on the PCS is considerably lighter because the design is more traditional – it does not span from cabinet side to cabinet side as it does on the ICS. Additionally, there is a smaller tabletop, a smaller cabinet to house the internal workings, a plastic motor cover (the ICS door is sheet metal) and the dust shroud on the PCS is also plastic instead of cast iron (as it is on the ICS). However, the plastic shroud on the PCS is moulded to improve dust collection – something all but impossible to do with cast iron.



**Locked out.** The throat insert lock – lift the bail handle – is outstanding. But a shop-made replacement seems out of the picture and \$39 is a lot to pay when you need a replacement.

And dust collection is, according to the company, around 99 percent when you use the improved blade guard with the molded-in dust port. (SawStop is working on a complete system that will have one port that will collect from the guard and the base. But to reach 99-percent collection at this time there are two ports to which to attach hoses and you need an additional dust collector, vacuum or shop-made rig.)

The saw performed as you would expect. The fence system glides on its rails and locks in position like a door on a jet. The 3-horsepower motor allows easy rips and crosscuts even through most gnarly woods – but I would suggest that you replace the included 40-tooth blade. A quality 50-tooth blade improved the cut substantially.

Bottom line: This saw is a good option if you feel the need for the safety provided by the braking system, but it's not the ICS in a shrunken version.

— Glen D. Huey

CONTINUED ON PAGE 30

PHOTOS BY AL PARRISH

## Lie-Nielsen's Thin-plate Tenon Saw

The more I saw by hand, the more I prefer a thin sawplate. Having a thinner wafer of steel makes the saw easier to push – that's because there's less weight and the tool has to remove less wood.

There is, of course, a downside. Thin sawplates are a little more fragile so you need to keep the tool away from the ham-handed. But in even slightly skilled hands, I think you'll find thin saws are a revelation.

Lie-Nielsen Toolworks has now started making a thin-plate version of its tenon saw, and it is one of the best tenon saws – old or new – that I've ever used.

The tool is large – the blade is 16" long – but it weighs only 1 lb. 7 oz. That's because the sawplate is .02" thick. That is significantly thinner than the company's other tenon saws, which are .032" thick.

The other critical specification here is how much blade you have under the brass back. The Lie-Nielsen has a whopping 4 1/8". Now before you dismiss that as too much, hear me out. Many 18th-century tenon saws were sized like the Lie-Nielsen. And

because steel was very expensive then, they had to have a good reason. Here's my guess: I find a larger tenon saw is more accurate. With the heavy back of the tool high above the work, it's easier to sense when the tool is plumb. And tenon cheeks are almost always cut so they are plumb.

I have absolutely zero complaints about this Lie-Nielsen saw. Its 11 points-per-inch blade starts incredibly smoothly thanks to the hand-filed teeth (even beginners have commented on this aspect of the saw to me). And the tool plunges quickly through even difficult ring-porous hardwoods.

In my book, this saw is the new standard



**Lie-Nielsen 16" Tenon Saw**

Lie-Nielsen ■ 800-327-2520 or  
[lie-nielsen.com](http://lie-nielsen.com)

Street price ■ \$175

For more information, go to [pwfreeinfo.com](http://pwfreeinfo.com).

for tenon saws. Strong words, I know. But if you give the tool a try I think you'll agree.

— Christopher Schwarz

## Bosch Brad Nailer is Smaller and Lighter

The Bosch BNS200-18 brad nailer is part of the company's new "Full Force Technology" line of air tools, all of which have a patented air chamber that allows the nailers to use 100 percent of the air from the compressor to drive the fastener. In traditional nailer designs, some air is kept in reserve to return the tool to the ready position. Among the other tools in the line that many woodworkers use are a 15-gauge angled finish nailer and a 16-gauge straight nailer.

The upshot is that these new nailers are smaller and lighter than comparable tools on the market (Bosch says they're 20 percent smaller and 10 percent lighter), which means that for someone like me (small hands, little upper body strength), this 18-gauge brad nailer is easy and comfortable to use, plus the body is narrow, so there's a better line-of-sight to the workpiece.

I was particularly pleased with the tool-less adjustable depth-of-drive, as I used the nailer to attach some thin poplar trim. It was simple to turn the adjusting wheel until I got the drive depth I needed.

The tool also features a toolless "quick clear" feature to access the tip to clear jams, but I didn't experience any jams in two hours of use. It is, however, easy to access the tip.

A dry-fire lock-out feature prevents blank firing, which is nice for those of us who have "attached" an entire run of moulding, just to discover that, no, we haven't. That lockout prevents damage to both the workpiece as well as the interior mechanisms of the tool.

The selectable trigger is another good feature; it allows you to switch easily (again, with no tools) from bump firing to sequential firing.

My one complaint about the brad nailer is that it didn't come with an air-hose coupler. I know these are inexpensive and easy to find at any hardware store, but I didn't realize I needed a coupler until I was ready to use the tool. So, I had to stop what I was doing



**Bosch Brad Nailer**

Bosch ■ 877-267-2499 or  
[boschtools.com](http://boschtools.com)

Street price ■ \$126

For more information, go to [pwfreeinfo.com](http://pwfreeinfo.com).

and traipse to the store before I could get started. It's not a big deal, and I was pleased with the nailer's performance, but it was annoying at the time.

The 18-gauge brad nailer weighs in at 2.5 pounds (with the coupler and brads removed), and takes fasteners from 5/8" to 2" in length. **PW**

— Megan Fitzpatrick



***Compact 12v***  ***Drill-***





These small tools pack a punch. What might seem a step down actually has big benefits.

**D**rill-drivers have moved through different battery voltages like a NASCAR driver moves through gears at Talladega. Many manufacturers pushed through 18 volts and upward to 24 volts, with a few reaching the 36-volt area. Then the power was downshifted and leveled at 18 volts, and along the way the newest power source was installed much like a new motor on a race car. Pushed aside are Ni-Cad and the other older power supplies to be replaced by the latest and greatest batteries known as Lithium-ion.

As we move forward, drill-driver size has become important. Some consider 18-volt drill-drivers too heavy for non-stop use on the job, but like to have the power when needed. Nobody wants to hoist a heavy drill all day long. As a result, compact drill-drivers stepped into action with their lighter weight and smaller dimensions.

# Drivers

BY GLEN D. HUEY



*Compact drill-driver shootout. We test tools from Bosch, Makita, Hitachi, Milwaukee, Craftsman and Ridgid.*

Compact drills are great to use for extended periods of time, but if you have to work in small areas such as inside cabinets, even these tools can feel oversized. To squeeze into tight places and to make the job easy and less burdensome on our arms, wrists and shoulders, 12-volt drill-drivers are back in the spotlight.

These drill-drivers include  $\frac{1}{4}$ " hex-drive tools as well as standard chuck designs. To whittle down the list of candidates for our review, we set parameters that we felt would be the best choice for everyday use. Drill-drivers with  $\frac{1}{4}$ " hex heads are OK for some operations such as driving screws. But for simple drilling tasks, we didn't want to have to have a dedicated line of tooling (drill bits with  $\frac{1}{4}$ " hex shanks). We decided that two-speed drills that afforded the operator the choice of torque settings, and had conventional chucks in a  $\frac{3}{8}$ " size, were the best bet.

While you might think that this list

of requirements is limiting, we found six contenders that met our parameters. The six include the Bosch PS30-2A, Craftsman's NEXTEC drill-driver, the Hitachi DS10DFL, Makita's DF330DW (the only 10.8-volt tool in the test), the Milwaukee 2410-22 and Ridgid's R82008 drill-driver.

## About the Tests

For comparison to the larger drill-drivers reviewed in April 2008 (issue #168), we set about to drill holes in  $1\frac{3}{4}$ "-thick poplar using 1"-spade bits and to drive  $\frac{1}{4}$ " lag screws that are  $1\frac{1}{4}$ " in length into the same thickness of poplar. Each phase was completed beginning with a fully charged battery. For the drilling phase, we set the tool to the highest speed and for the lag-screw portion of the test we selected the lowest speed.

As a simple comparison, the lowest number of holes drilled with the 18-volt tools was 19 (the highest was 37). With

CONTINUED ON PAGE 40

# Compact Drill-Drivers



## Bosch PS30-2A

The Bosch 12-volt drill-driver is certainly a handful of tool. It's near the top in handle girth (6<sup>1</sup>/<sub>8</sub>"") and tied for the top in the drill-head-length measurement at 7<sup>7</sup>/<sub>8</sub>".

With a price tag at \$131 and change, the PS30-2A is the fourth-most expensive drill-driver in our test.

The PS30-2A drilled a test-leading 8 holes in the 1" spade-bit drill-a-thon. It also has the lowest upper-end speed setting in the group.

In the lag-screw test, the Bosch drill-driver performed admirably by installing nearly 32 lags. While that number was not the most lags driven, it was enough to position the tool in fourth place.

We all know that heat is a destructive force on batteries as well as tool life, but even with more than eight holes drilled, and the battery depleted, the PS30-2A registered a motor temperature of 108° (just below the mean temperature). And at 136°, the battery temperature was also positioned in the middle of the pack.

This tool gave our top pick a run for the money given its ability to drill holes and drive lags, but in the end, the PS30-2A was nudged out due to tool design. During use, the back of the drill rides heavily on the area between your thumb and forefinger, causing soreness.

The Bosch PS30-2A, two batteries and a charger are packaged in a canvas case. Additional batteries are \$33.



## Craftsman 11812

The Craftsman NEXTEC drill-driver has the third-smallest girth size and is one of the longest drill drivers in the test with a drill-head-length measurement of 7<sup>7</sup>/<sub>8</sub>".

The good news is that this drill-driver is the least expensive tool in our test (at \$80, it sells for \$69 less than the most expensive drill reviewed). Unfortunately, the NEXTEC drill is also the least productive of the drill-drivers tested. While six holes were driven through the 1<sup>3</sup>/<sub>4</sub>"-thick poplar before the 1.3 amp hour battery gave out (that was the third-highest test number for holes driven), only six lag screws were seated before the juice ran out on a fully charged battery. And those six screws required three attempts to drive them home due to multiple motor stoppages.

Also, the NEXTEC battery and the tool itself did not heat to the levels comparable with the other drills in the test (probably because of the lack of actual work). The tool's temperature tied for the lowest in the test with a drill that drove eight times as many lag screws. And the battery temperature topped out at 123°, again the lowest in the test.

The NEXTEC drill driver is great for occasional use in the shop, or for do-it-yourself work around the house, but we don't recommend this tool as your "go-to" drill in this category.

Replacement batteries are \$25 and the kit is packaged in a canvas carrying case.



## Hitachi DS10DFL

Hitachi's 3<sup>3</sup>/<sub>8</sub>" drill-driver is the only tool in the test that stayed with a traditional drill-driver design. The base of the tool is wide and holds the drill upright without issues. This allows for an easy pickup when reaching for the tool.

With the smallest girth in the review (5") and a middle-of-the-road measurement for the drill-head length (7<sup>1</sup>/<sub>2</sub>""), this drill fits comfortably in any small-to-medium hand.

The DS10DFL is priced around \$108, the second-most inexpensive tool in the test. So you may guess the tool would place near the bottom when drilling holes or driving screws. But that's not the case. In fact, with 48<sup>1</sup>/<sub>2</sub> lag screws driven, it's only one screw away from the best results in the test; that could be a result of the slowest low-end speed setting (300 rpm).

The number of holes drilled is slightly different. Here the Hitachi drill-driver completed five holes before the 1.5 amp hour battery pooped out.

Motor temperatures for the Hitachi drill ran on the high side of those tested at 114°. But the battery temperature rated second from the coolest at 127°.

One area of disappointment is the battery charger. There is little information on the unit; it simply indicates a charging battery and when the battery is fully charged. Overall, we are impressed with the Hitachi DS10DFL and think this is a good-quality drill for the money.

### Bosch

[boschtools.com](http://boschtools.com) or 877-267-2499

■ Street price: \$131.47

### Craftsman

[craftsman.com](http://craftsman.com) or 800-349-4358

■ Street price: \$79.99

### Hitachi

[hitachipowertools.com](http://hitachipowertools.com) or

800-706-7337

■ Street price: \$107.73



## Makita DF330DW

The Makita DF330DW places in the middle of the pack in both girth (5<sup>5</sup>/<sub>8</sub>" ) and in the drill-head-length measurement at 7<sup>1</sup>/<sub>2</sub>". It is noticeably top heavy and tips forward when set down. As a result, Makita's drill-driver will not stand upright.

The purchase price of the Makita drill-driver pushed it into the top half of all the drills in the test at \$134.

The DF330DW scraped the bottom of the tested tools in holes drilled with just four, but rebounded a bit when driving lag screws – 41<sup>1</sup>/<sub>2</sub> lags were driven on a single 1.3 amp hour battery that was fully charged.

Temperature testing came after the hole drilling phase and Makita's drill-driver reached higher-than-average recordings. The motor temperature reached a test-high 116° and the battery temperature hit a sweltering 168°, the highest in the test by 30°.

The most curious feature that stands out on this tool is why engineers selected a 50-minute battery charger to accompany this tool. It's the longest recharge time and makes the possibility of downtime while waiting for a battery to recharge a distinct possibility.

The Makita DF330DW is a good choice if you have an occasional need for a drill-driver of this size. But you'll have to move on if you're looking for a standout 12-volt, 3/8" drill-driver.

Battery replacement cost is \$40.

## Milwaukee 2410-22

The Milwaukee drill-driver is the standout tool in this test. It's a stout tool that fits comfortably into larger hands – the girth size is tied for the largest at 6<sup>1</sup>/<sub>4</sub>" and the drill-head length is 7<sup>1</sup>/<sub>2</sub>".

The \$149 purchase price is tops in the test as well, but in this case the outlay of funds is justified.

The 2410-22 has the highest torque rating and the highest, high-end rpm rating in the group. It is the leader in both test categories with eight holes drilled and 49<sup>1</sup>/<sub>2</sub> lag screws driven, each on a single 1.4 amp-hour battery charge.

After the eight holes were complete, the tool temperature came in tied for lowest at 105° and the battery temperature was a respectable, although not the lowest in the test, at 138°.

The Milwaukee 2410-22 is also the only drill-driver tested to include a fuel-gauge indicator light and the LED shines upward to help light up the work area.

If pushed to come up with a downside to this drill-driver, I would have to comment on the size and weight of the tool. Small hands will find this drill-driver to be thick, but very usable. And there is a noticeable weight difference when compared to the other drill-drivers tested.

Bottom line: This drill-driver is at the top of the category and is well worth your investment dollars.

Replacement batteries are \$39.

## Ridgid R82008

This drill-driver is available as part of a kit only. The kit includes the R82008 drill-driver, two 1.5 amp-hour batteries, a 30-minute charger and a flashlight that works off the same batteries. If you need the flashlight, there's extra value here.

The Ridgid R82008 drill-head-length measurement is the shortest in the test at 6<sup>3</sup>/<sub>4</sub>". It also had one of the highest girth measurements in the group. But if you need to squeeze into a small work area, this might be your tool. It is very compact and thick not only at the grip area, but at the nose as well. The single latch to release the battery from the tool is located on the backside of the battery. You have to change your grip to make the switch.

The Ridgid R82008 came in just below average with five holes drilled and ranked second from the bottom in total number of lag screws driven at 24<sup>1</sup>/<sub>2</sub>, which is surprising given its 240 inch-pounds of torque.

The R82008 registered a cool 105° reading on the motor, which is tied for the coolest motor temperature. It didn't fare quite so well in the battery temperature at 138°.

Overall, this is a good-working drill-driver, but I don't think the tool performed well enough in the test to reach a "buy" decision. Even with the added flashlight I don't think the kit is the choice to make.

Replacement batteries for the R82008 are available for \$40.

### Makita

[makita.com](http://makita.com) or 800-462-5482

■ Street price: \$133.99

### Milwaukee

[milwaukeetool.com](http://milwaukeetool.com) or 800-729-3878

■ Street price: \$149

### Ridgid

[ridgid.com](http://ridgid.com) or 866-539-1710

■ Street price: \$139



the lower-voltage drill-drivers in this review, the greatest number of holes is eight. The results are similar when the lag-screw portion of testing is compared. It's easy to see that these drill-drivers are not the tools to grab if you have heavy-duty work to perform. But after you work with these tools for an extended period of time, you'll notice less wear and tear on your body.

The tests are best for a comparison between like tools and not to indicate workload capabilities. And because the purpose of these smaller voltage drill-drivers is comfort during use, it may be better to gauge the feel of the tool in your hands, how balanced the drill-driver is or isn't and whether the battery charge is in line with the competition, along with other characteristics.

### Comfort is Key

A quick look at the chart at right reveals two important areas when the overall feel of the drills is discussed: girth measurement and the total weight of the tool (the drill-driver and the weight of the battery).

To choose an appropriate girth measurement, you have to evaluate your hands as a beginning. Obviously, if you have large hands, a small girth such as the 5" on the Hitachi DS10DFL is going to swim in your grip. But with medium-sized hands, I found this drill-driver to be comfortable to use and easy to grab.

The "easy to grab" part of the equation could be due in part to the battery design. Hitachi is the only drill-driver in the test to keep the battery design similar to that of larger drills, with a wide base design that holds the tool upright for easy pick-up. Hitachi's competitors have all adapted a smaller battery that slips inside the handle of the tool, and that increases the girth of the drill-driver.

Contrarily, if your hands are larger, you may find a better fit with large-girth drills. If that's the case, the Milwaukee 2410-22 or the Ridgid R82008 could be your choice. Both of these drill-drivers have a girth of 6<sup>1</sup>/<sub>4</sub>", the largest in the group.

The average weight for the 18-volt drills is 4.1 pounds. The heaviest drill-driver in this review is 2.64 pounds and the average is 2.57 pounds. That tells me a couple things. First, the difference between 18-volts and the lower voltage drill-drivers is significant—1.46 pounds is better than a 50-percent increase in weight over the smaller drills.



**Classic old versus new.** Hitachi stayed with the tried-and-true design similar to that of larger drill-drivers. Other manufacturers moved toward a new design of fitting the battery into the handle.

Your arms and shoulders will feel better after working a full day with any of these tools versus an 18-volt drill-driver.

Second, there is little weight difference when comparing these drill-drivers to each other. Overall, there is a difference of only 6<sup>3</sup>/<sub>4</sub> ounces between the heaviest and lightest of these tools. In my opinion, tool weight can be discounted as being too close to warrant a choice based solely on this characteristic.

### A Tip of the Drill

As for overall balance, a few of these drill-drivers feel more top-heavy than the others. The Bosch and Makita drills tip forward when set in the upright position, indicating that these drills would roll your wrist downward when put to work. The Craftsman and Ridgid tools sit upright, but tip with the slightest touch. The Milwaukee drill-driver, the heaviest tool in the test, is balanced and stands squarely on its battery-filled base.

Another area where comfort becomes apparent is with the over-molded grips and the shape of the tool as it rests in your hand. Most of the drill-drivers have a gentle rounded shape at the rear of the tool, directly behind the trigger. The Bosch and Ridgid tools, however, form an acute angle that rubs the area between your thumb and forefinger. Not comfortable.

### Rotation and Speed Selection

Each drill-driver has a rotation selection switch for forward and reverse movement, and a lock position. Push the switch fully to the left and the drill rotates to drive a screw. A switch pushed fully to the right backs a screw out of your workpiece. And the center position, which is hard to find on a couple



**Comfort is key.** The acute angle at the rear of the Bosch tool causes discomfort to your hand during prolonged use. The more opened angle on the Makita tool makes it more comfortable to use.

of these drill-drivers, is the lock position. (The lock position is used when drill bits or screwdrivers are replaced.)

The Makita tool has the smallest rotation switch while the Craftsman switch is the largest and most noticeable. It is also the switch that's the most difficult to operate.

Because there are operations when you need to increase or decrease the rotation speed, each drill-driver has a two-speed gearbox. As a result, changing those speeds is of importance.

Each of the tools has the speed selector on the top of the tool. On the Hitachi and Craftsman drill-drivers, to select the low-speed setting you push the selector forward, and to move to the higher gear, you pull the selector back. The other tools in the test work in the reverse way.

Overall, the selector on the Hitachi drill-driver is the stiffest and hardest to adjust, while the others are easy to change.

### Other Interesting Attributes

All the tools in this test have common attributes, such as multiple torque settings so you can dial in the exact amount of torque for any given task (although I seldom adjust the torque settings) and each drill-driver includes two batteries so the idea of completing a job without any downtime waiting on batteries to recharge is minimal. (All the tools have 30-minute chargers except for the Makita DF330DW, which has a 50-minute recharge time).

Interestingly, each of the tools in the test require a two-finger grip, with a quick squeeze, to change the batteries. For all the drill-drivers except the Ridgid, the grip is across the width of the tool. To change the

battery on the Ridgid, you pinch the battery from front to back. Even with the difference in how the batteries are replaced, the operations to change out the power sources are equally smooth and easy.

### Shine-on LED

Another feature that most drill-drivers have—and all the tools in this test have as well—is a light emitting diode (LED). And because these tools are great for enclosed areas, the LED differences should be discussed.

The standout LED is on the Makita driver. It is brighter than the others in the test. And more important, the LED comes on when the trigger is slightly depressed. The Makita LED also stays illuminated for 10 seconds after the drill stops, then it fades off.

The Ridgid LED is the second brightest. It, along with the Milwaukee LED, is noticeably angled upward when compared to the others.

The Milwaukee tool is the only one with a fuel-gauge light to indicate battery power. As the trigger is depressed, the LED shines, and for a period of two to three seconds, a fuel gauge light illuminates with one to four dots, depending on the remaining charge.

### Which Drill-driver to Choose

Choosing a 12-volt drill-driver should not require that you give up on the tool's ability to be a workhorse in the shop just because you need to work in tight areas. But comfort is also a concern with repeated use. So which drill driver do you choose?

The Editor's Choice award goes to the Milwaukee 2410-22. It's the overall best tool. It powered through the 1" holes and amassed a whopping 49½ driven lag screws. And there is plenty of torque to do the job.

The 2410-22 registered a lowly 105° motor temperature and scored near the average in battery temperature (138°). Excessive heat should not shorten this tool's life.

The Milwaukee drill-driver is well balanced and comfortable in your hand. The rotation switch and speed selector are easy to use without being switched inadvertently.

Also, the Milwaukee single-sleeve chuck is the only all-metal chuck in the group.

But if the \$149 price tag on the Milwaukee drill is too steep for your budget, take a look at our "Best Value" drill-driver. Hitachi claims this honor with the DS10DFL.

The test numbers for the Hitachi drill are good, but are still behind those posted by



**An onboard fuel indicator.** The Milwaukee 2410-22 drill-driver is the only tool tested that includes a battery fuel-gauge indicator. One to four lights illuminate to show the amount of charge remaining in your battery.

Milwaukee's drill-driver. The tool is comfortable in small to medium hands, but large hands may find issues with it.

The Hitachi drill-driver is about \$40 less expensive than the 2410-22 and is considerably lighter. And I particularly like the old-school battery/base design. **PW**

*Glen is a senior editor of this magazine, the author of several woodworking books and the host of several woodworking DVDs. Contact him at 531-513-2690 x11293 or glen.huey@fwmedia.com.*

### Compact 12V Drill-drivers

DRILL/DRIVER MODEL #	BOSCH PS30-2A	CRAFTSMAN NEXTEC 11812	HITACHI DS10DFL	MAKITA DF330DW	MILWAUKEE 2410-22	RIDGID R82008
STREET PRICE	\$131.47	\$79.99	\$107.73	\$133.99	\$149	\$139*
WEIGHT W/ BATTERY (LBS.)	2.37	2.21	2.39	2.32	2.64	2.53
BATTERIES INCLUDED	2	2	2	2	2	2
BATTERY AMP/HOUR	1.3	1.3	1.5	1.3	1.4	1.5
TORQUE SETTINGS	20+1	17+1	21+1	18+1	20+1	17+1
REPLACEMENT BATTERY	\$32.95	\$24.99	\$38.99	\$39.95	\$39	\$39.97
RECHARGE TIME	30 min.	30 min.	30 min.	50 min.	30 min.	30 min.
RPM	0-400 0-1,000	0-400 0-1,300	0-300 0-1,300	0-350 0-1,300	0-400 0-1,500	0-320 0-1,300
LAGS DRIVEN	31 <sup>7</sup> / <sub>8</sub>	6	48 <sup>1</sup> / <sub>2</sub>	41 <sup>1</sup> / <sub>2</sub>	49 <sup>1</sup> / <sub>2</sub>	24 <sup>1</sup> / <sub>2</sub>
HOLES DRILLED	8	6	5	4	8	5
MOTOR TEMPERATURE	108°	105°	114°	116°	105°	105°
BATTERY TEMPERATURE	136°	123°	127°	168°	138°	138°
TORQUE (INCH POUNDS)	220	195	195	200	250	240
ON-BOARD LED	yes	yes	yes	yes	yes	yes
VOLTAGE	12	12	12	10.8	12	12
GIRTH MEASUREMENT	6 <sup>1</sup> / <sub>8</sub> "	5 <sup>7</sup> / <sub>8</sub> "	5"	5 <sup>5</sup> / <sub>8</sub> "	6 <sup>1</sup> / <sub>4</sub> "	6 <sup>1</sup> / <sub>4</sub> "
DRILL-HEAD LENGTH	7 <sup>7</sup> / <sub>8</sub> "	7 <sup>7</sup> / <sub>8</sub> "	7 <sup>1</sup> / <sub>2</sub> "	7 <sup>1</sup> / <sub>2</sub> "	7 <sup>1</sup> / <sub>2</sub> "	6 <sup>3</sup> / <sub>4</sub> "

\* Only available as a kit with flashlight

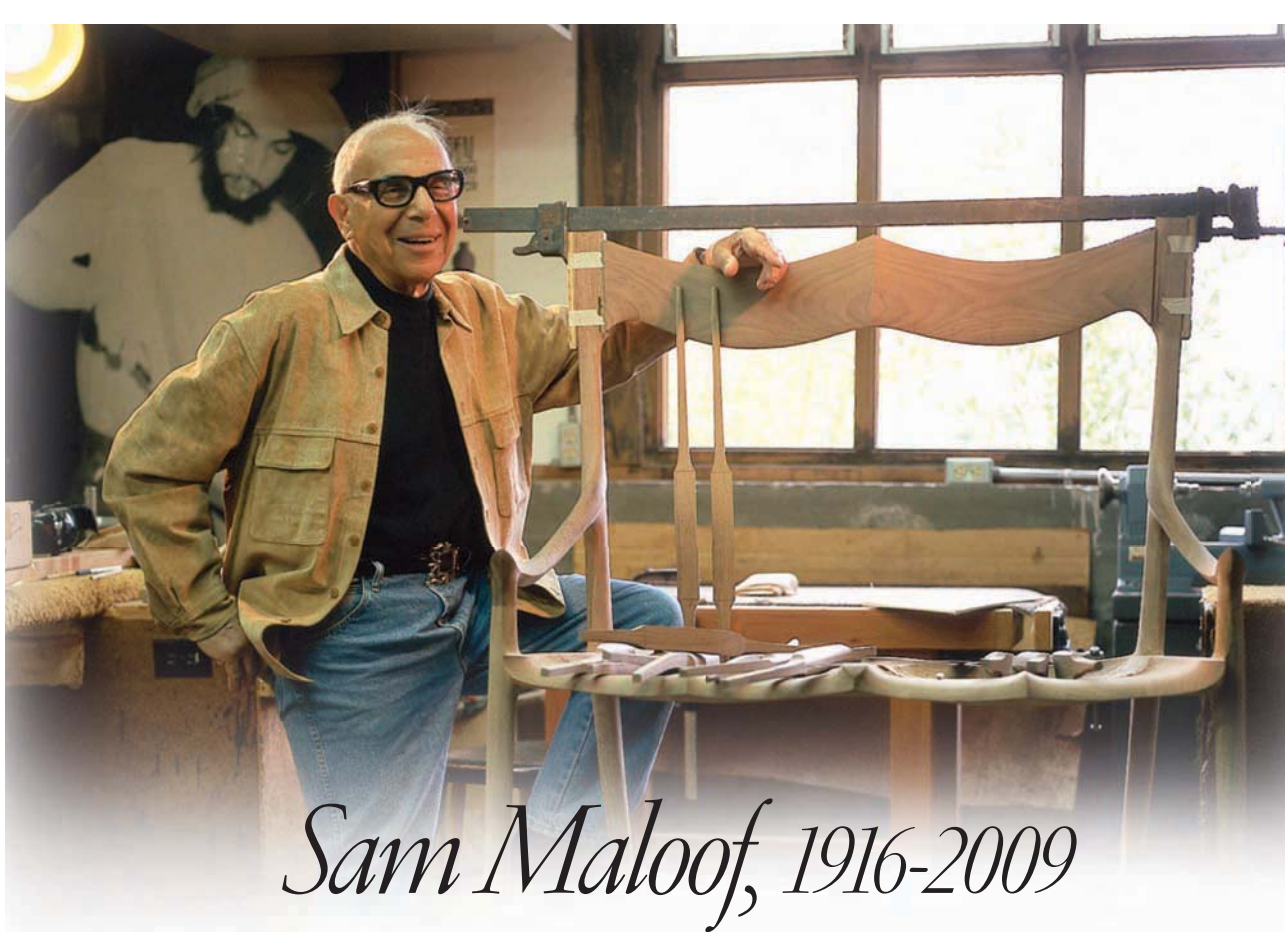

## Sam Maloof, 1916-2009

Designer and builder of elegant but simple iconic furniture.

BY JOHN ECONOMAKI

Sam Maloof is the reason I became a furniture maker. I used to teach shop in the early 1970s. The Portland (Ore.) Public Schools maintained an audio/video depository for teachers and in those days most of the technical choices were film strips with the requisite recording that beeped when it was time to roll forward. Dorky. The heat from the projector was unbearable.

My woodshop “classroom” was small and consisted of a series of tiered benches surrounded by windows reinforced by chicken wire – a needed safety measure to protect students from the occasional explosions in the adjacent welding lab.

Sometime in 1974 I noticed a film titled “Sam Maloof: Woodworker” and ordered it for review. The next day after classes, I rolled in the projector and watched a movie about a woodworker who was unknown to me. It is probably important to mention that I was 23 years old and 1,800 miles from home.

Time erodes my memory, but I believe the film was around 30-40 minutes in length and I watched the film five times in a row. It was the most humbling experience of my life. Here I was teaching woodworking and

*Sam Maloof, the son of Lebanese immigrants, was born in Chino, Calif., and served in the U.S. Army during World War II. He returned to Southern California after leaving the army in 1945, and married Alfreda Ward in 1948. Maloof began out of necessity building furniture for their house from salvaged materials. After receiving some commissions, he and Freda moved to Alta Loma, Calif., where he opened a studio and built a home that is now on the National Register of Historic Places. Three years after Freda's death, he married Beverly Wingate and built a second home on the property; the first is now open to the public. Maloof's iconic work is in several major museums, and in the White House.*

realizing that I knew nothing about woodworking.

Produced by Maynard Orme (who later served 19 years as the president and CEO of Oregon Public Broadcasting), “Sam Maloof: Woodworker” was impossible for me to ignore. I remember a raging internal debate as to whether I should show this to my students for fear of exposing my own

ignorance. But I could not keep this from my kids.

I have now seen that film well over 50 times and have learned something with each viewing. At that time, I did not know about pattern shaping, never had seen a rolling pin sander, and it never occurred to me that wood could be sculpted in such fashion. I hate to admit it, but at that time I was Forrest Gump-dumb in regard to woodworking – probably everything else too.

Within a year another film made the catalog, featuring Wendle Castle's music rack (can't remember the title). It was a cool how-to film set to Modest Mussorgsky's “Picture at an Exhibition.” Then in 1975 I received the first issue of *Fine Woodworking* (which I still own). I did not know it at the time, but my life was being swept up in a woodworking tsunami that spanned the entire planet. I don't think we will ever see a wave this big again.

It was early 1978 when I noticed an ad in *Fine Woodworking* for the Anderson Ranch in Snowmass, Colo. Listed was a three-week summer hands-on workshop with ... Sam Maloof!

It was dusk when I pulled into the Anderson Ranch and while driving into campus I noticed a barn with doors wide open. Alone inside was Sam Maloof oiling a rocking chair. I was such a star-struck wimp that I quickly sped past to the check-in counter for chickens.

The Anderson Ranch woodworking classroom was two columns of workbenches. I took the very last bench because I would not like to look around, or over, a 6'3" awe-struck fellow like me who hogged the view.

On the third or fourth day an interesting thing happened. Sam's glasses broke at the bridge and for the rest of the class, they were held together with white tape – Hanson-brother style for you hockey fans.

The significance of this event was transformative for me because I then realized Sam was just as susceptible to life's quirks as the rest of us. I also noticed that he worked fast. Really fast.

One of my fondest memories of Sam is from that class, in which I made my first scooped chair seat. I was so excited and was eager for Sam's approval when I thought my chair was ready for oiling.

"It will be fine when you get all the bumps out." He informed me, as I wondered how his stovepipe fingers could feel anything. "What bumps?" I asked; it appeared perfect to me.

"Are you right- or left-handed?" Sam asked. "Left," I said. "Put a pencil in your left hand, close your eyes and feel the seat with your fingertips. Every time you feel a bump, color it with the pencil with eyes closed. Dents are bumps on all sides. Do this until you think you are done. Do not open your eyes, and use all ten fingers."

When I opened my eyes my chair seat was almost entirely black. I was not only shocked, but really discouraged. I scraped all the marks off, and repeated the process five or six more times. In the end, when the finish was dry, it was easy to see the grace and flow of the sculpted seat. It made the light sing; the work was not only worth it, but its own reward. It was then I knew furniture making was for me.

When Sam left my station after sharing what I needed to do, he reminded me that you are half done with a piece when it is ready to sand. That also was an eye-opener. I then realized that you are not green forever and that this class with Sam Maloof would change my life in unimaginable ways.

Finally, I raised my hand again. Sam came by, ran both of his hands over my chair seat, smiled, and walked over to another student. It was the best day.

On the last day of class there was a picnic. Sam sought me out and apologized for not spending much time with me. It was a grand gesture, sincere and he really did feel bad. I told him I was not there to talk but to learn and that I was going to go home and quit my job to be a furniture maker. It was the easiest decision I ever made.

Before we parted company Sam asked to see my portfolio. All I had were a couple pictures of a try-square I designed for my beginning woodshop classes – I was really embarrassed. In his customary way, he told me he thought the try square was beautiful.

Within a couple of years my work – strongly influenced by Sam's forms – was being accepted by juries. At some point Sam called to congratulate me and I confessed how hard it was to design without thinking about how Sam would do it. He told me not to worry, that this will pass and I will find my own voice. It was not long before I had a three-year backlog of work and just as Sam predicted, my later work bore no resemblance to his own.

I never once saw Sam wear a dust mask, and neither did I. My furniture-making career came to a quick halt in 1983 with a hyper-allergic reaction to wood dust. Bridge City Tool Works was my last shot at self-employment.



**Legendary rocker.** The iconic Maloof rocker has been made for presidents, celebrities and captains of industry. Maloof used templates to guide the rough work, but allowed the final form of each rocker to change in response to the wood.

A couple of times a year there would be tool shows in the Los Angeles basin and I would stay with Sam and Freda on their lemon grove property. We would talk until Freda made Sam go to bed. It is here that I learned that objects should be worthy of the space they occupy – Sam surrounded himself with the visual richness of others in addition to his own work. There was a canoe hanging from the ceiling – how cool.

## Customer and Friend

Sam was an avid customer of Bridge City and during one trip I asked him where all the tools were that he had purchased. They're right here behind the sofa, he said, and he pulled out a box and opened it. I said, "Why don't you use them?" "I do," he replied. "I tell everybody about these beautiful tools."

Craftsmanship meant a great deal to Sam and I will never forget it. The ego will let your eyes lie, but your fingertips never will. To this day, when I teach, I explain that if something is supposed to be flat, then it better be flat because the light will expose your intent as flawed.

And if you allow these sorts of compromises then the honor of calling oneself a craftsman cannot be done in good faith. I learned that anybody can do mediocre work but fine work, well, this takes dedication, understanding, patience and desire. Making something worthy of the space it occupies is not only hard, it is imperative. This lesson has been the driving force behind Bridge City tools for the past 25 years.

My last visit with Sam was a year ago; I took Sam and "the boys" to lunch. Sam asked to see our latest tool, which was the CT-14 Shoulder Plane. When I told him the price, Sam commented, "\$800 is a lot of money for a plane." I retorted, "\$35,000 for a rocking chair is a lot of money for a piece of furniture."

One of the boys interrupted: "Sam, you are not going to win this one."

And with a wink, he put the handplane on his lap and asked if I could send him an invoice.

I don't believe Bridge City would exist without Sam Maloof. And like so many others, I desperately wish he were still here.

Thanks Sam. PW

---

John is the founder of Bridge City Tool Works in Portland, Ore.



## *James Krenov, 1920-2009*

A woodworking teacher and writer whose influence will live on.

BY RON HOCK

**T**here is a short list of woodworkers whose work defines a style and is recognizable at first glance. Those on it have undeniably influenced other woodworkers, shaped our culture and molded our tastes. James Krenov is on that list.

Jim (everyone called him “Jim” or “JK”), who died Sept. 9, 2009, in Fort Bragg, Calif., was born in Wellen, Siberia in 1920. He moved to Shanghai as a child before emigrating with his family to Alaska. The Krenovs later moved to Seattle where Jim built and refurbished yachts at Jensen Motorboat, later serving as a Russian Language Interpreter for the Lend-Lease Program before and during WWII.

Then he moved again, this time to Europe where Jim began to build architectural models. He met his future bride, Britta, in Paris; they were married in 1951. He attended the Malmsten School in Stockholm for two years before striking out on his own, gradually

building a reputation for innovative design. Following the publication of his first book, “A Cabinetmaker’s Notebook,” Jim began teaching woodworking at schools around the world. His influence as an artisan with a viewpoint and passion reached far beyond his classrooms and his own shop.

During my art school years, a frequent topic of discussion regarded the essential difference between art and craft. Through the years I’ve adopted a simple criterion in my ongoing effort to understand the issues: Craft needs to be functional; art does not.

A chair, no matter how “artful” the design, must perform a certain, familiar function: It must be strong enough for an average person to sit in and comfortable enough to want to. If the “art” part of the chair’s design takes it outside those simple parameters, it may not be a chair anymore. It may be sculpture (art). Art expresses aesthetic elements without concern for function. Craft must

include consideration for the utilitarian function of the object: one we can sit on, cover our bed with, or display our treasures in. Memorable craft-works combine exceptional aesthetic design with both hand and engineering skills – skills that do not necessarily constrain the artist. Craft is at its most memorable when it blends aesthetics with the physical, utilitarian demands of the object being crafted.

So it is with the works of Jim Krenov. His iconic cabinets embody a rare synergy of art and craft – genuine artistic brilliance executed with flawless craftsmanship. At the very first glance, Jim’s work is striking and recognizable on purely aesthetic terms. His proportions always satisfy; the materials draw the eye; his passion for the wood is obvious. On closer examination, the fit and finish, attention to detail and flawless construction all combine to further enhance the experience. The wood itself is the domi-

nant design element in each piece, and this initial impression is reinforced as a more intimate inspection reveals beautiful grain orchestrated and harmonized throughout the piece. Added decoration is minimal, a restraint all the more apparent with Jim's additions of simple, hand-carved pulls and handles. Hardware is just enough to allow doors to open, only what is needed to allow the piece to function as designed. And, it is impossible to stand before one of Jim's cabinets and not open a door, pull out a drawer, to touch it. The tactile is as satisfying as the visual: Drawers glide with a whisper, doors close with a puff. They are simply magnificent.

While his cabinetmaking had the power to change the world on its own, it is James Krenov (his *nom de plume*) the philosopher who influenced a global audience through his books: "A Cabinetmaker's Notebook" (1975), "The Fine Art of Cabinetmaking" (1977), "The Impractical Cabinetmaker" (1979), "Worker in Wood" (1981) and "With Wakened Hands" (2000). All are highly recommended. As I peruse the online forums, reading memorial statements from woodworkers regarding Jim's influences on them, I am struck time and again by how someone's life was changed by Jim's writings, how statements like, "His book showed me a new way of working, of looking at wood" are common. How many books about craft in general or any craft in particular have influenced so many so profoundly? In addition to his brilliance as an artisan, Jim's writings are a remarkable legacy in their own right and will be remembered forever as pivotal treatises on 20th-century craft.

### Beginning of a Business, Friendship

I moved to Fort Bragg in October 1981 which, serendipitously, was the very month of the grand opening of Jim Krenov's Fine Woodworking Program at the College of the Redwoods. In all my years of art school, I never saw classes as energetic and open, students who are as dedicated and sharing, nor teachers more professional and expert than those in that program. Ideas, skills and tools are shared with enthusiasm, honesty and trust. New work is presented to generous, constructive criticism.

Jim worked at a bench in the classroom and openly shared inspirations and techniques, solved problems, fielded endless questions about his or the student's work,

and presented his finished works to the class, just as the students do. He left large shoes to fill when he retired in 2002 but the instructors had for the most part been there for years, some since the early 80s, working and teaching with Jim. They continue today teaching the "Krenov" approach to—and love of—wood and woodworking. Jim's legacy lives not only in his works and books, but in the school and curriculum he developed and in the hundreds of students he taught from around the world.

I am surely the luckiest blademaker in the world. I was making knives—a lone craftsman in the woods—one at a time, selling them at craft fairs, when one of the instructors approached me to make some blades for the planes that Jim advocated so glowingly in his teachings and books (he called the plane "the cabinetmaker's violin").

At that time there were no decent blades or cap irons available anywhere. So, Jim and his students used mediocre replacement blades from the hardware store and found creative solutions to the cap iron problem. Together, Jim, his assistants and students helped me come up with a blade to suit Jim's



**Iconic cabinet.** This spalted maple cabinet on legs, completed in April 1995, typifies Krenov's unparalleled approach to working with grain patterns.

wooden plane. Jim, especially, was pleased with my products and would take my brochures and sample blades when he went to do his "song and dance" around the country. I once asked him if I could say "Krenov-style" to describe the blades in an ad. Without hesitation he said, "Say 'Krenov-quality.' It sounds better!"

My friendship with Jim continued from this support in the early 80s until his death. I'd show up at the school's shop, wares in hand, and he'd shout out, "Hold on to your wallets, Ron's here!" More recently, when asked how he was doing, he'd often reply with, "Not bad for an old man" or, "We aren't buying any green bananas!" His thin and scratchy voice still rings in my ears. His 2002 retirement was only from teaching, as Jim continued cabinetmaking for several more years until his failing eyesight prohibited the close detail work his craft demanded.

Though Jim no longer made furniture, his love of woodworking and working in his shop never diminished. He embarked on making planes to keep himself busy. I had the pleasure of providing him with plane irons, which meant that Jim and I kept regularly in touch as he busily made planes (by feel, more than by eye). He'd call me for more blades and I'd sharpen and deliver them to his house. Jim had a reputation for being demanding, sometimes difficult, but he was always grateful and gracious when I arrived, and made sure we caught up about our families and our various endeavors.

As the visual fog of late-stage glaucoma increased, Jim sometimes needed help adapting his shop so he could continue to work. Modifying his grinder with a wider wheel to increase the target area when he ground a blade; adding an additional task light at the band saw to help see what he was cutting. (Yes, in spite of rather severe visual impairment, he still used his power tools in the making of his signature planes. At some point I no longer cringed with fear; who could stop Jim Krenov?) He was always very appreciative of my small efforts to help his work and I always enjoyed visiting with him and his wife, Britta.

I often say that through his writings, teaching and uncompromising dedication to craft, Jim launched the careers of a legion of woodworkers—but maybe just one metalworker. Thanks, Jim. We'll miss you. **PW**

Ron founded and owns Hock Tools in Fort Bragg, Calif.

# BIBLIOPHILE'S BOOKCASE

BY MEGAN FITZPATRICK

With simple lines and straightforward joinery,  
this project yields ample shelf space (and drawers to boot).

**T**his large case-on-case shelving unit is adapted from similar pieces I've seen in private libraries and in stately homes. I also dug up a few pictures from the Sotheby's and Christie's auction sites, where the form is referred to as a "bibliothèque" (also the French word for library).

Those examples, however, all feature intricate mouldings and fancy corbels and are more adorned than would look right in my less-than-stately 1895 home. I do, however, have 10' ceilings and an embarrassment of books, so while I didn't want fancy, I did want big. So I reconceived the form in a Shaker-on-steroids style – the piece is just shy of 50" wide x 90" high. It will fit in a room with standard ceiling heights, but in case I ever needed to use the top and bottom separately, I installed a solid top for the bottom case so it can stand alone (and with the addition of a cushion, it would make a handsome hall bench).

The size did have me fretting about stock costs, so I culled the "shorts" bin at our local lumber store for lower-priced cherry, and found a nicely figured wide piece for the drawer fronts, as well as sufficient stock for the lower case and all the shelves. The shelves are made of some rather homely boards,

but because I added a lip to the front for strength and appearance, you can't actually tell – unless you remove the books and take a close look. I did have to go to the regular-price rack for the upper-case face frame and sides, but I saved money by using poplar for the backboards, which I painted to match the trim in the living room.

## Bottom's Up First

First, I cut my parts to rough sizes then surfaced and thickened all the stock but the drawer fronts, and glued up panels for the sides, lower case top and upper case top, and all the shelves. I never cut my pieces to final size until I need them – and then I mark cuts using the project as a guide, not the cutlist. No matter how meticulous I am with the measuring, things are never perfect. But, once my pieces are cut to size, I plane and finish-sand as much as possible before assembly because it's hard to maneuver around a piece the size of a New York apartment.

Because I didn't have a 7"-wide piece for the lower rail, or two 49"-long pieces with matching grain that I could glue up, I had to scab on a 4" x 14" piece at each rail end for the curved feet (the downside of parsimony).

I then traced my pattern onto each foot,

cut it at the band saw and smoothed the cuts on a spindle sander – but had to resort to hand-sanding where the curve met the flat.

After setting up the mortiser with a 1/4" bit, I made a 1 1/2"-wide mortise for the 2"-wide center stile dead in the middle of the lower rail, then moved to the table saw to cut 1 1/4"-long tenons on each end using a dado stack.

Holding the workpiece took a little thought, because the two feet created a not-solid surface on the bottom edge (a good argument for spending a little extra to make the lower rail and feet out of one board – or at least a solid panel glue-up, and cutting the tenons before cutting out the feet). But no worries – a 3"-long offcut clamped to the sliding table did the trick. I cut each tenon face in two passes, first removing 3/4" or so at the end before pushing the end against the fence to remove the remainder of the waste on each shoulder.

The resulting tenon was 6 1/2" wide – on the cusp of too wide to offer sufficient mortise-wall strength – so I split it by sawing out a 1"-wide piece with a coping saw, then chiseled the shoulder flat while removing the remaining waste. I cut 1 1/4" tenons on the upper rail and center stile at the table saw,



**Simple shelves.** Though it's large, this Shaker-inspired bookcase is fairly simple to make – and three adjustable shelves make it simple to fit books of all sizes.





**Scabby feet.** Because I had very little extra stock, and not enough with matching grain to glue up a solid panel for the curved bottom rail, I had to scab on the foot piece at either end.



**Cut the curve.** I traced my pattern onto each foot and made the cuts at the band saw.

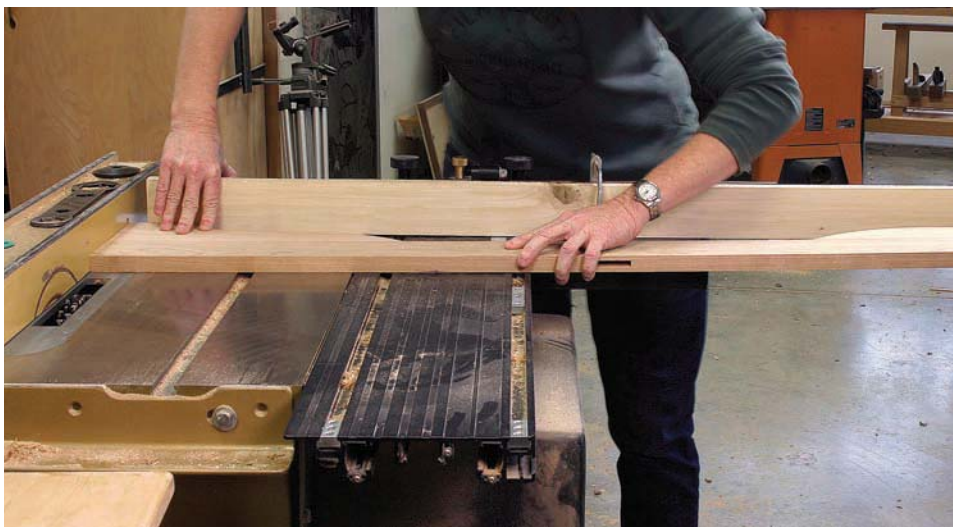

**Jigged up.** Because the feet created a non-flat surface, and the sliding table is shorter than my workpiece, I simply clamped a flat piece of scrap to the fence against which I could hold the rail while I made the tenons.

marked then cut the mortises on the side rails at the mortiser. After I glued together the face frame and set it aside to dry, it was on to the side pieces.

I marked the curved cutout on each piece, then made the cuts at the band saw. (Note: the apex is not centered; it's  $\frac{3}{4}$ " closer to the front.) Because the full dado stack was still in place, I went ahead and added a sacrificial fence, then cut a  $\frac{3}{4}$ " x  $\frac{7}{16}$ " rabbet up the back of each side piece to house the backboards. In retrospect, I should have cut an 11" stopped rabbet, because the backboards don't go all the way to the floor. While the unnecessary 7" portion of rabbet doesn't show, the base would be stronger without it.

I adjusted the dado stack to make a  $\frac{3}{4}$ "-wide cut, and made a  $\frac{1}{4}$ "-deep dado across each side piece 7" from the bottom (the top edge of the dado is flush with the top of the lower front rail) to accept the web frame, which is joined with pocket screws. I glued the web frame into the dados on each side, squared it up and tightened the clamps. After the glue dried, I glued on the face frame and attached a rail across the top of the back, flush with the backboard rabbets, with pocket screws.

## Upper Case

First, I cut the mortises and tenons for the face frame and glued it together (luckily, no one had adjusted the mortiser from when I did the lower face frame). I made it about  $\frac{1}{8}$ " oversized on the sides (as I did with the lower case face frame), so I could flush it easily to the sides later with a flush-trim router bit.

Then it was on to the side pieces, and cutting dados for the bottom and middle fixed shelves. Workholding was tricky here, because the side pieces are  $70\frac{1}{2}$ " long—well over the edge of the saw table. So, I clamped a handscrew around the crosscut sled fence, on which to rest the overhanging part. This, however, meant I couldn't use the stop on the sled, so a stepoff block on the fence solved the problem to locate the  $\frac{3}{4}$ " dados for the fixed bottom shelf.

I also cut  $\frac{3}{4}$ " dados in each side  $30\frac{3}{8}$ " from the bottom for the center fixed shelf, and marked and drilled holes for the adjustable shelf pins. The locations were figured from a graduated shelf progression—but with the remaining three shelves adjustable, it's unlikely that progression will ever be evident.



**Split tenon.** A 6 $\frac{1}{2}$ "-wide tenon is too big, so I split it using a coping saw then chiseled out the remainder of the waste.

### Stiff Lips

With the sides done, I cut the bottom and middle shelves to size (note that the widths are different; the bottom shelf has no lip), and glued a 1 $\frac{1}{2}$ "-wide lip across the front edge of the middle shelf, leaving just better than  $\frac{1}{4}$ " of the shelf's front edge uncovered at each end to slip into the dados.

After the glue dried and I sanded the lip flush, I ran a bead of glue in each side-panel dado, set the fixed shelves in place flush with the front edge of the side, clamped across, then toenailed the fixed shelves in place. Be careful with the angle of your nail gun and the length of your nails. I blew through the side once. OK, maybe three times.

While that glue-up dried, I added lips to the three adjustable shelves, keeping them just shy of either end to make shelf adjustment easier (the face frame covers the shelf ends, so the gap won't show).

Next, I added the face frame, and got a little help clamping it up square – there was simply no way for me to reach corner to corner to pull things into place without assistance. Then, I pocket-screwed a rail at the top edge to which I later attached the backboards.

### Topping Things Off

I cut the upper- and lower-case tops to size, and rounded over the edges with #80-grit sandpaper until I liked the way it looked, then progressed through grits to #180 until the shaped edge was smooth.

The lower-case top is attached with L-shaped wood buttons, and has a 1" overhang on the front and at each side; the upper-case top (to which the crown attaches) has a 2 $\frac{7}{8}$ " overhang on the front and either side. It's screwed to the back rail, sides and face frame.



**Framed.** The pocket-screwed web frame was glued into the side panel grooves and squared up before I tightened down the clamps.



**More jigs.** Again faced with secure workholding problems at the table saw, I used a handscrew attached to the sliding table to support one end, and an stepoff block at the other to safely locate the groove for the bottom fixed shelf.



**Toenails.** Be sure you have 1 $\frac{1}{4}$ " nails in your gun – or if it's loaded with 1 $\frac{1}{8}$ " nails, make sure you angle your shots enough so that you don't blow through the sides. Or keep the nippers handy.



**A little help please.** With a big glue-up, it's best to rope a friend into helping. By oneself, it's difficult to tighten all the clamps down quickly without things sliding around – or reach corner to corner should you need to square things up. Or click a camera button from 9' away.



**Crown moulding.** To make a simple crown, angle your stock at 45° to the blade and center the blade on the stock (or cut it just off-center so you have a thicker flat on one edge, if you like that look). Then clamp a long offcut beyond the blade to serve as a fence. Make repeated cuts in each piece of stock, raising the blade a little each time. Stay tight against your fence and to the table. Though I'm not wearing one here, a dust mask would be a good idea.

## Bibliophile's Bookcase

NO.	ITEM	DIMENSIONS (INCHES)			MATERIAL	COMMENTS
		T	W	L		
<b>Upper Case</b>						
□ 1	Upper rail	3/4	5 <sup>3</sup> / <sub>4</sub>	47 <sup>3</sup> / <sub>16</sub>	Cherry	TBE*
□ 1	Lower rail	3/4	3	47 <sup>3</sup> / <sub>16</sub>	Cherry	TBE
□ 2	Stiles	3/4	2 <sup>5</sup> / <sub>8</sub>	70 <sup>1</sup> / <sub>2</sub>	Cherry	
□ 2	Sides	3/4	11 <sup>1</sup> / <sub>4</sub>	70 <sup>1</sup> / <sub>2</sub>	Cherry	
□ 1	Bottom fixed shelf	3/4	10 <sup>1</sup> / <sub>2</sub>	48 <sup>15</sup> / <sub>16</sub>	Cherry	
□ 1	Middle fixed shelf	3/4	9 <sup>3</sup> / <sub>4</sub>	48 <sup>15</sup> / <sub>16</sub>	Cherry	
□ 3	Adjustable shelves	3/4	9 <sup>3</sup> / <sub>4</sub>	48 <sup>1</sup> / <sub>4</sub>	Cherry	
□ 4	Shelf lips	3/4	1 <sup>3</sup> / <sub>4</sub>	48	Cherry	
□ 1	Top	3/4	14 <sup>7</sup> / <sub>8</sub>	55 <sup>11</sup> / <sub>16</sub>	Cherry	
□ 2	Crown	3/4	4 <sup>1</sup> / <sub>4</sub>	54	Cherry	Rough size
□ varies	Backboards	5/8	varies	70 <sup>1</sup> / <sub>2</sub>	Poplar	
<b>Lower Case</b>						
□ 1	Upper rail	3/4	3	47 <sup>3</sup> / <sub>16</sub>	Cherry	TBE*
□ 1	Lower rail	3/4	3	47 <sup>3</sup> / <sub>16</sub>	Cherry	TBE
□ 2	Feet	3/4	4	14 <sup>1</sup> / <sub>4</sub>	Cherry	TOE**
□ 2	Outer stiles	3/4	2 <sup>5</sup> / <sub>8</sub>	18	Cherry	
□ 1	Center stile	3/4	2	10 <sup>1</sup> / <sub>2</sub>	Cherry	TBE
□ 2	Sides	3/4	12 <sup>3</sup> / <sub>4</sub>	18	Cherry	
□ 1	Top	3/4	14 <sup>1</sup> / <sub>2</sub>	51 <sup>15</sup> / <sub>16</sub>	Cherry	
□ 2	Drawer fronts	3/4	8	21 <sup>1</sup> / <sub>4</sub>	Cherry	Size sides, bottom to fit
□ varies	Backboards	5/8	varies	11 <sup>3</sup> / <sub>4</sub>	Poplar	
<b>Web Frame</b>						
□ 2	Long rails	3/4	2 <sup>1</sup> / <sub>2</sub>	43 <sup>15</sup> / <sub>16</sub>	Poplar	
□ 2	Short rails	3/4	2 <sup>1</sup> / <sub>2</sub>	12	Poplar	
□ 1	Center stile	3/4	4	7	Poplar	

\* Tenon both ends, 1<sup>1</sup>/<sub>4</sub>"; \*\* Tenon one end

## A Dusty Crown

I dislike making crown moulding. It is incredibly dusty, and my arms get an unwanted (but not unneeded) workout pushing 3/4" stock at an angle across the table saw blade. But there's no getting around it. So I had to set up the table saw, suck it up (the dust, that is) and get it done. And then there's the sanding. Lots of sanding.

The simplest way to fit the crown is to invert the upper case, then wrap the moulding around the front and two ends. Secure it to the top, sides and face frame with brads.

## Put Your Back Into It

My backboards are shiplapped random-width poplar, and in the upper case they're painted. I did cut a chamfer on the front of each for added visual interest – not that it will show when the case is loaded with books.

In the lower section, the backboards are unpainted and have no chamfer – but they do run vertically to match the top. (If you

## Online EXTRAS

To watch a video of making crown moulding and for more information on fitting crown, go to:

[popularwoodworking.com/dec09](http://popularwoodworking.com/dec09)

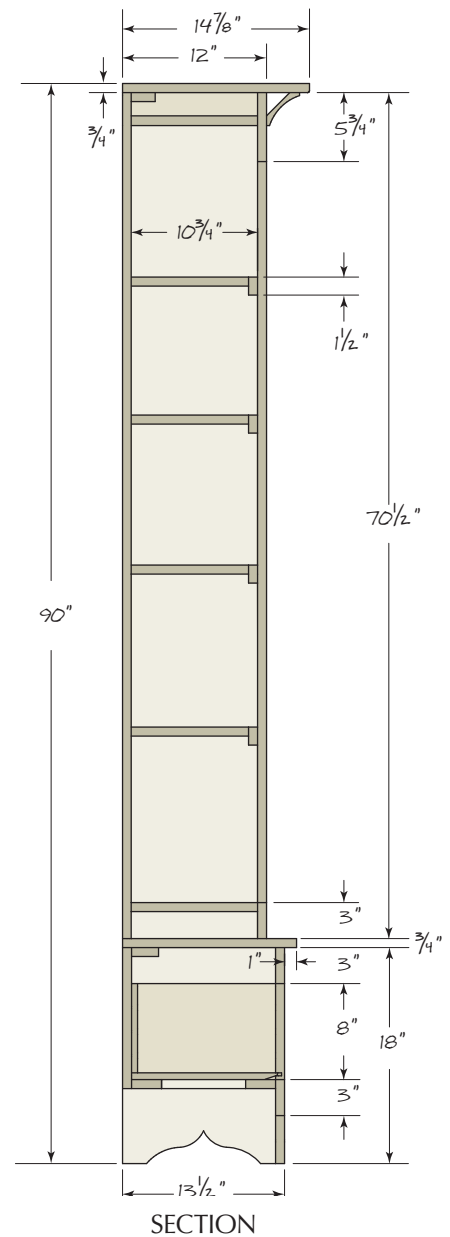
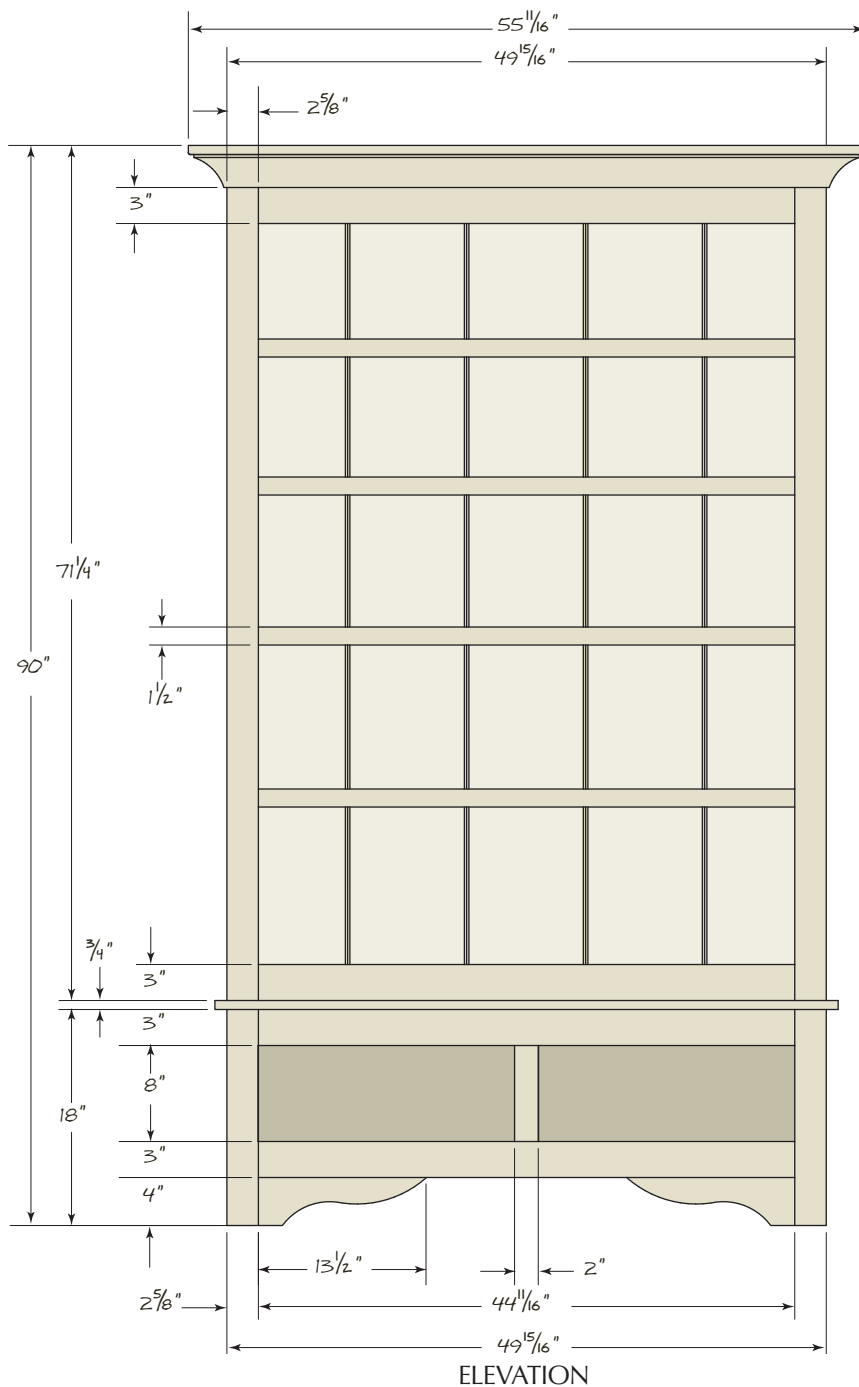

have an 11"-wide piece, you could get away with one board, run horizontally. But your co-workers might snicker at the idea.)

### Hidden Storage

Last, I fit the inset drawer fronts and constructed drawers with half-blind dovetails at the front, and through-dovetails at the back. The bottom is an upside-down raised panel slid into a groove (the back edge isn't beveled), then secured to the drawer back with a 1 1/2"

shingle nail. I suspect these drawers would have originally housed candles and perhaps paper and writing implements; I'm using them to store extraneous cat toys.

The finish is two sprayed coats of amber shellac (with sanding after each) and a top coat of pre-catalyzed lacquer. **PW**

*Megan is managing editor of this magazine. She can be reached at 513-531-2690 x11348 or [megan.fitzpatrick@fwmedia.com](mailto:megan.fitzpatrick@fwmedia.com).*

### Supplies

#### Rejuvenation

888-401-1900 or [rejuvenation.com](http://rejuvenation.com)

4 ■ square bin pulls in oil-rubbed bronze #EC 7004, \$7 ea.

#### Rockler

800-279-4441 or [rockler.com](http://rockler.com)

1 ■ 16-pack of 1/4" shelf supports #33902, \$4.89

*Prices correct at time of publication.*

# Build a Boomerang

BY TREVOR SMITH

Making a boomerang is simple, fast and will set your head spinning.

If you like a challenge, enjoy having an excuse to be outside and are looking for ideas for practical projects, you'll find that building a boomerang is great fun.

Also, boomerangs are a great project to build with family members you've wanted to introduce to woodworking. And when you are done you get to go to the park and spend time together throwing them.

I have just one warning: Boomerangs will draw a curious crowd of onlookers.

## A Little Science of Boomerangs

Here's the first rule of boomerangs: Do not be afraid of trial and error. There are a wide variety of shapes that will work.

Boomerangs operate on the principle of "gyroscopic precession," which is similar to

riding a bike no handed and attempting to initiate a turn. In bike riding, the spinning (gyroscopic) motion of the wheels gives the bike stability. To execute a "no hands" bicycle turn, you simply lean the bike in the direction that you wish to turn. The wheels have a delayed reaction to the force of the leaning action. This way, the wheels actually feel the force a quarter turn from where the force was applied. So instead of falling over, the bicycle turns in the desired direction.

Unlike riding a bicycle with "no hands" while turning, the boomerang experiences a continuous turn as the force is applied for the duration of the flight. The boomerang is thrown with a slight tilt from vertical (more on this later). The gyroscopic nature of a spinning boomerang and the release angle (called the "layover angle") causes the boomerang's flight angle to flatten out as it turns. Thus a well-balanced, well-contoured and well-thrown boomerang will return to the thrower in a horizontal hover. Most people expect that this will take practice though.

The duration of flight is determined by the force with which the boomerang was thrown as well as the spin applied at launch.



**About to take flight.** The students loved watching their classmates throw boomerangs almost as much as they enjoyed throwing them. Above, Jon Roberts throws his "Bat-erang" as his friends observe his effortless (athletic) throwing technique from a safe distance behind. From the look on Jon's face it is easy to see that Troy High School students take boomerangs very seriously.



**Here's the windup.** "Beast" was one mean flying wing. Demonstrating that not only do you have to have a carefully made boomerang for success, but also good throwing form, Do H. Kim throws the boomerang he made. Notice the pinch grip as Do Kim prepares to release his boomerang into flight. Everyone would stop to watch when "Beast" was launched; it flew that well.

As with any object flying through the air, a boomerang is subject to drag its own weight as it makes its flight pattern. This drag slows the boomerang down, thereby limiting the flight time. However, given enough spin and initial velocity, the boomerang will circle above the thrower's head a few times before landing.

### Choosing a Shape And a Material

Even if you don't fully understand how boomerangs work, you can still make one that flies quite well. There are a wide variety of plans available on the Internet (type in "boomerang plans" into any search engine). Or you can start with the scaled plans here or download full plans from the *Popular Woodworking* web site that you can print and adhere directly to the wood.

For your first boomerang, pick a simple design, which will be easy to make and throw. In other words, it is best not to pick a complex design that is for trick flying.

The traditional wood used by the aboriginal tribes of Australia to make boomerangs is

**Plywood that flies.** Boomerangs come in a surprising number of shapes. All of these versions fly. This article shows you how you can make your own flying wing with just a few hours of shop time.

Myall brigalow (*Acacia harpophylla*). According to George Simonds Boulger in his book "Wood: A Manual of the Natural History and Industrial Applications of the Timber of Commerce" (BiblioLife), this native wood is "brown, strongly violet-scented, very heavy, very hard, elastic, durable, splitting freely. Used for turnery, tobacco-pipes, vine-stakes, spears and boomerangs."

A practical, quality and easy-to-work-with material for this project is plywood. However, the plywood at the big box stores isn't a good choice. Boomerangs are essentially flying wings, and better grades of plywood are more durable. In fact some plywoods are engineered for flying projects.

When I teach high school physics students to build boomerangs, I prefer to use 1/4"-thick Baltic birch or Finnish birch. Baltic birch costs less, but Finnish birch is lami-

nated with waterproof glue so it can hold up better outdoors. The two plywoods are easy to tell apart. The glue lines for Baltic are similar in color to the wood. The waterproof glue used in Finnish birch is a dark chocolate color.

### Rough Out Your Boomerang

Once you have your wood and a pattern, you'll need to gather the tools. You need some sort of saw that can cut curves, such as a band saw, coping saw or bowsaw. To smooth the shape and thin the edges of your boomerang you need files and sandpaper. A spindle sander is nice to have, but it is not required.

If you are going to make several boomerangs in one shape, I recommend you make a pattern. We use paper bags, poster board or thin plastic sheeting.



**Start with a simple pattern.** Melanie Jonas traces a bi-wing pattern onto 1/4" plywood. The next step is to head over to the band saw. This pattern was so popular that I made a wooden pattern for the students to be able to trace.

Transfer the boomerang's shape to the wood blank. Then cut the shape out with your saw. I use this opportunity to teach the physics students how to use a band saw safely. Many students have never used power tools and this was a great way to introduce their safe use.

I survey my students about their experiences with the tools, and here's what one female student, Lo Struga, had to say about the band saw: "It felt like the first time I heard the Beatles, it was amazing."

Once the shape of the boomerang is sawn out, you can refine its outline with a spindle sander or files and sandpaper.

### Shaping the Airfoil

Now you need to make some important decisions. Like golf clubs, boomerangs are "handed." How the boomerang's airfoil is laid out and shaped depends on whether the person who is going to throw the boomerang is right-handed or left-handed.



**Swooping cuts.** There are two large Pow-ermatic band saws in the school shop. Our Industrial Technology teacher, Al Merian, was a great help, generously making the shop available to the physics students. Here Danny Forche is cutting out his boomerang while a line of students wait their turns at the band saw. Just like woodworking school.

The illustration below shows the airfoil shape of a right-handed boomerang. For a left-handed boomerang, you simply reverse the airfoil shape.

First mark the top of the boomerang. As with airplane wings, the airfoils on a boomerang have a leading and a trailing edge. The leading edge is a quarter-round shape and the trailing edge tapers off the top of the boomerang like the cross-section of a typical airplane wing. Mark the two leading edges and the two trailing edges so you do not file them incorrectly (a common mistake my students make). The bottom face of the wing is completely flat.

Lay out the leading and trailing edges of the wings based on which hand will do



**Smooth edges soar.** At the spindle sander, Todd Geiser refines the edge of his boomerang blank. The spindle sander is an efficient tool for smoothing the perimeter of the boomerang. Getting one smooth and fair line all the way around the boomerang is the goal at this stage.

the throwing. A marking gauge can be used for this (or the old trick of holding a finger against the edge). Mark in on the top the distance that the contour retreats back from the boomerang's edge to its top surface.

The quarter-round shape generally extends about 1/4" from the edge, while the trailing edge extends about 1" to 1 1/4" into the material. Note that you only have to shape one face of the plywood. The other face is left flat. See the illustration below to understand how the airfoil shape looks on a simple "V"-shaped boomerang. Note how the leading edge and trailing edge change along the length of the boomerang.

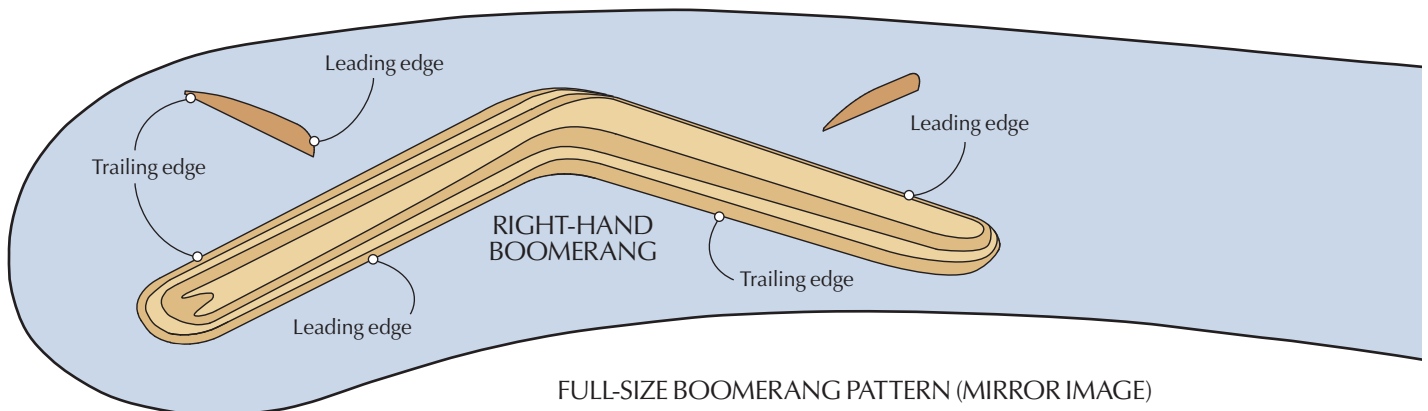



**Rasp your airfoil.** Clamps help to steady the boomerang blank while the airfoil is brought to life. In this photo, Mike Laba uses a rasp to make quick work of the shaping process. Notice that Mike has positioned the boomerang off the edge of the bench so the rasp does not damage Mr. Merian's benches.

Shape the airfoil with rasps, files and sandpaper. There are a variety of rasps available out there. We use Nicholson cabinetmakers No. 49 and 50 cabinet rasps. These tools fascinated the students and they understood their importance to the whole process.

"The files (and rasps) were indeed important in the success of our boomerangs because the files sculpted the airfoils," Drew Jarvis commented.

And Whitney Regalski added: "Without files, the shape I was shooting for would never have been accomplished."

A boomerang is actually a flying rotating rotor, like on a helicopter. The airfoil shape needs to be consistent, and this is where the plys in plywood help in the design of the project. As the glue lines appear from the plys it is easy to observe the progress when shaping of the airfoils.

The optional finishing touch to shaping the airfoil is to slightly bevel the back edge



**Fine-tune with sandpaper.** After a couple test flights, Andrew Mihoc adds some refinement to the shape of the airfoils on this tri-blade boomerang with some sandpaper.

of the wing (if you wish). Or, another option is to make some test throws first and see if your boomerang is making a complete turn. If it is not, then file a slight back bevel on the flat face of the leading edge.

Before you decorate your boomerang, you should take it for a test spin because you might want to refine its airfoil.

### Throwing Technique

When teaching students to throw a boomerang, we start by using example boomerangs made with paper and cardboard in the classroom.

Throwing requires a little practice, so it is worth the time to make a few quick cardboard practice boomerangs. Cereal boxes are a great raw material for this. You can make a quick cardboard boomerang using two strips of cardboard approximately 1" wide and 8" to 10" long. Use hot-melt glue to form them into the shape of a plus sign. Put a gentle upward curl on the four blades and throw using the same techniques described below for throwing wooden boomerangs.

The throwing technique has a few key components, regardless of the material. Pinch the boomerang between your thumb and index finger and hold it over your head.

Your thumb grasps the airfoil shape. The index finger is against the flat face of the boomerang.

Now hold your arm perfectly vertical. Before you throw, you need to tilt your arm 10° to 20° away from your

body. This is called the "layover angle." See the illustration on the next page for what this looks like.

The throwing motion employs a lot of wrist action to generate the necessary spin around the center of mass of the thrown wing. Throw the boomerang at an angle of 45° from the front of the body. (That's with straight out in front being 0° and arms held straight out at the sides being 90°.) The angles are guidelines to get you started in the right direction. Do not be afraid to experiment with the throwing angles.

When throwing a boomerang outside, the wind should be light and blowing straight into your face. The throw is still 45° from the front. Aim for a point about 10° above the horizon. This will send the boomerang flying. See the illustrations on the next page for details.

One of the important reasons to make indoor boomerangs before making wood ones is to learn the throwing motion. Indoors, the flight patterns are smaller, and the feedback for good and poor throws and working designs occurs quickly. The cardboard 'rangs are quite harmless if they hit someone, too.

Once everyone is able to prove that they can throw a boomerang and not a "stick" or "kylie" (as a non-returning boomerang is called in Australia), then it is time to find a place outside to throw your wooden version.



**Perfect form.** Just as it begins to rain, J.D. Dennison cannot resist one last throw of a tri-wing boomerang. Tri-wing boomerangs spin very fast, but do not fly as far as the more traditional bi-wings. It is easy to see from Dennison's wind-up that boomerangs can be thrown quite hard.

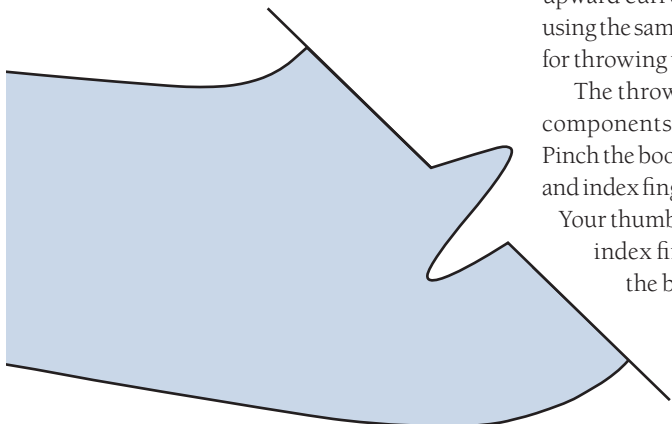



## Find a Space to Throw

The larger the throwing area the better, especially when learning to throw. Parks are areas worth scouting. A football or soccer field is a good-size space to start with. There is less chance of losing a boomerang if the area is very large. Do not throw in an area where there are children, pets, cars or structures that may get in the way.

After five years of teaching physics students to make and throw boomerangs, there have been a few surprises. One surprise is

just how well the boomerangs fly. The other shock is just how much the students enjoy the entire process. They carry their boomerangs around the school and even trade boomerangs with one another.

And a few times every year some students will bring some boomerangs to class that they didn't make at school. Yup. The students have been at home making boomerangs with their parents. One female student said that she didn't have any interest in her dad's shop until they made a boomerang together. In

several cases, the student's parents became so interested in the boomerangs that once the kids showed their parents (and even grandparents) how to make them, they would make boomerangs on their own. **PW**

---

*Trevor is a physics teacher at Troy High School. He was introduced to woodworking in middle school woodshop. He now creates furniture pieces and wood turnings in his home workshop. Smith also teaches various woodworking skills and project classes at the Woodcraft store near his home in Sterling Heights, Mich.*

## How to Throw a Boomerang

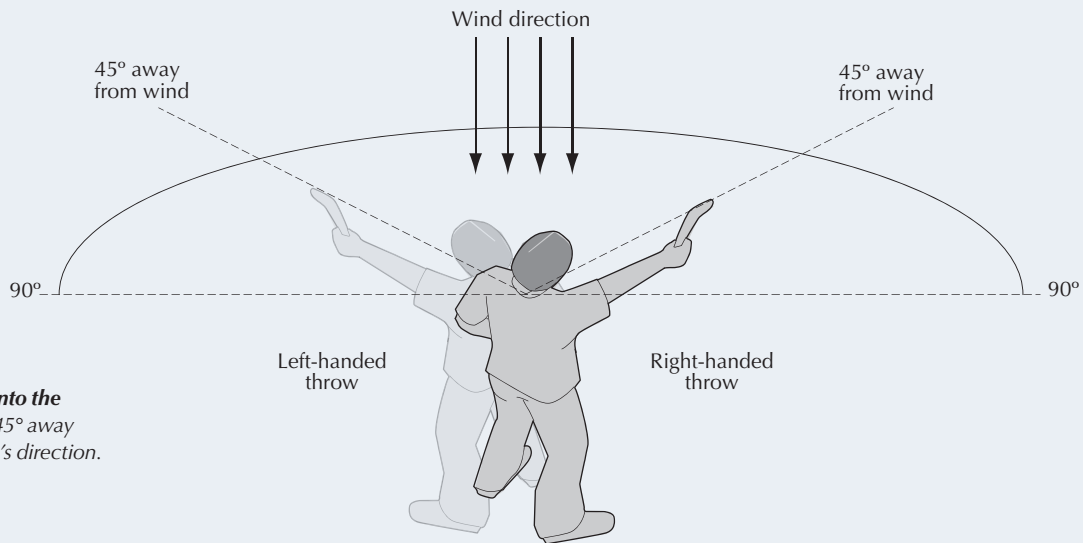

**Don't throw into the wind.** Aim at 45° away from the wind's direction.

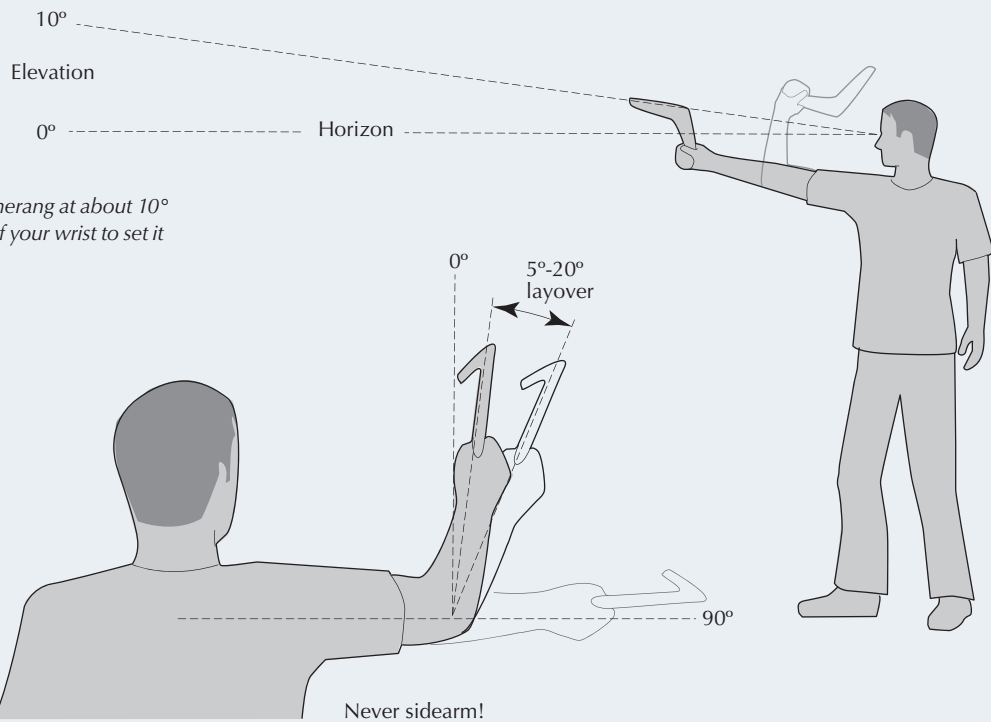

**Where to aim.** Throw the boomerang at about 10° above the horizon with a flick of your wrist to set it spinning.

**Tilt your arm.** Angle your forearm away from your head (layover) to return the boomerang on your opposite side. If it passes too far away, hold your forearm closer to vertical when you throw.

# 2009 BEST NEW TOOLS



## *The Winners:*

**Benchcrafted**  
**Big Wood Vise**  
**Blue Spruce**  
**Eccentric Toolworks**  
**Grizzly**  
**Kreg**  
**Makita**  
**Red Tape**  
**SawStop**  
**Veritas**

# W

ith the world's economy taking a nose dive in 2009, we saw a lot of things happen to the tool-making community. Many of the major manufacturers, which were pummeled by the housing market, played it safe this year. Either they held out on introducing new tools that would require a big investment in the factories, or they diverted their resources elsewhere.

However, some toolmakers, particularly individual makers, small companies and lean manufacturers, kept going. And as a result we saw the most unusual crop of new tools and machines in a long time.

Many of the machinery makers were cautious in 2009, but Grizzly Industrial and SawStop in particular still seemed to be firing on all cylinders. And their efforts definitely show in this year's list of our 12 Best New Tools.

And on the hand-held power tool side of the market, Makita seems unstoppable when it comes to continuously refining the products in its strong areas (as least as far as woodworkers are concerned): cordless drills and miter saws.

But the big story is the number of the amazing hand tools we saw across the board in all price ranges. Check out the list. You'll see what I mean. And if you want to see reviews of our runners-up to this list, visit our web site at [popularwoodworking.com/dec09](http://popularwoodworking.com/dec09).

—Christopher Schwarz, editor

## BENCHCRAFTED Tail Vise

For years we've watched the quality of vise hardware decline as old-school factories closed. This year we've had a renaissance with some new vise makers coming onto the scene, including Lie-Nielsen Toolworks.

One of the most delightful newcomers has been Benchcrafted, a small Midwestern company that makes a simply awesome tail vise. I installed the tail vise onto my workbench and was blown away by how smoothly it moves and how firmly it grabs the work. Plus, unlike a traditional tail vise, this unit won't sag.

Everyone who visits our shop wants one. This is a lifetime vise.



BENCHCRAFTED  
■ [benchcrafted.com](http://benchcrafted.com)

## BLUE SPRUCE *Round Mallet*

Few tools in our shop get universal acclaim, but the new resin-impregnated mallet from Blue Spruce Toolworks sure comes close.

Since I purchased one of these mallets from the Oregon-based company, two of the other woodworkers in our shop followed suit.

The mallet is almost impossible to resist. It's the perfect weight (1 lb.) and size (8<sup>1</sup>/<sub>2</sub>" long). It's beautifully finished. It's perfectly balanced. But what is really astonishing about the mallet is how it can take a beating without getting beat up.

Most wooden mallets (round or square) become dogmeat in short order—no matter what sort of wood you use. The Blue Spruce sidesteps that problem by using an acrylic-infused head. Every pore is filled with plastic, yet the mallet feels like wood to your hands and responds like wood when you hit something. That is, it doesn't bounce like a rubber mallet.

It also has a lot of punch for a mallet of this size, though it's definitely not a wrist breaker like a cast-iron mallet can be.

I've had this Blue Spruce

mallet since February, have been using it just about every day and have yet to make a dent in it. It still looks as good as when I got it out of the box.

We think this plastic technology could be used in other woodworking tools. Blue Spruce already uses it in handles for bench chisels. It would be great for the handles of mortise chisels—those receive a whupping. It also could be used in the totes for saws and planes—these are notoriously fragile. How about a wooden try square made from it? (I assume the acrylic reduces or eliminates the expansion and contraction process.) Hammer handles? Stay tuned.



BLUE SPRUCE TOOLWORKS  
■ [bluesprucetoolworks.com](http://bluesprucetoolworks.com)

## SAWSTOP *Contractor Saw*

By now everyone knows about the patented and effective sawblade-stopping technology that is the heart of every SawStop machine. But what everyone doesn't know is just how good the contractor version of this saw is.

When equipped with the company's T-glide fence and solid cast iron wings, this is a serious woodworking saw. The fit and finish is outstanding and the guarding system is excellent (SawStop was among the first to embrace the new guards). And I don't think we've ever had a contractor saw in here that was as easy to assemble.

In working with the saw, we found it to be stable and powerful—it has a 1<sup>3</sup>/<sub>4</sub>-horsepower motor like many hybrid table saws.

If you spring for the saw, we also recommend the excellent mobile base, which lifts the saw with ease and is quite stable.

To be sure, the SawStop costs more than other contractor saws, but it's a no-compromise machine. Not on quality. And not on safety.



SAWSTOP  
■ [sawstop.com](http://sawstop.com) ■ 866-729-7867

## VERITAS *NX60 Block Plane*

Veritas has a well-earned reputation for making excellent hand tools at reasonable prices, so some people thought this Canadian company had gone off the deep end when it introduced a \$279 block plane.

We, however, love the thing. It is quite possibly one of the most curvaceous and beautiful block planes I've ever seen. The level of fit and finish (check out the elliptical knurling) is off the charts.

And we are also wild about the nickle-resist ductile iron in the plane's body. This makes the plane both durable and extremely corrosion resistant. And some of us like how shiny it is.

We now think that Lee Valley Tools sells the most complete range of one-handed planes, from its \$39 "Little Victor" plane on up to this masterpiece of design and engineering. If you want the coolest-looking block plane in your city, call Lee Valley Tools.



VERITAS  
■ [leevalley.com](http://leevalley.com) ■ 800-871-8158

## ECCENTRIC TOOLWORKS *Backsaws*

This year I picked up a dovetail saw and carcass saw that blew me away. They were, compared to peers, the first among equals.

The backsaws from Andrew Lunn's Eccentric Toolworks are super-tuned jewels. They start more easily than any Western saw I've used – much like a Japanese saw. They fly through stock with ease. They are extraordinarily balanced and leave but a whisper of a kerf behind.

And on top of all that, the saws have beautiful handmade touches (such as carving on the tote) that make them as nice to look at as they are to use.

Yes, these saws cost more than your typical premium Western saw. But the Eccentric saws are a bargain when you compare them to blacksmith-made saws from Japan, and they really do cut in that league, in my opinion.

Each saw is hand sharpened, set and tuned by Lunn until he is completely satisfied with its performance. There's a bit of a waiting list for Lunn's saws now that the word is out. You might want to get in line now because it's only going to get longer.



ECCENTRIC TOOLWORKS  
■ [eccentricwoodcraft.com](http://eccentricwoodcraft.com)

## GRIZZLY *G0636X Band Saw*

In the 14 years I've been with *Popular Woodworking*, we have been through more than a dozen band saws of all sizes and all makes. Though there were many good saws on that list, there was never one that we wanted to keep in our shop forever (like our old Powermatic 66 table saw).

This year, however, we brought the Grizzly G0636X band saw into our shop at the magazine and we are in heaven.

This 17" saw outclasses and out-cuts many of the more expensive saws out there. And – here's the important part – the saw stays in alignment better than any of the other saws we've tested over the years. One of the biggest flaws of many band saws is that you need to fuss with them a lot to really unlock their potential.

This saw's cast iron wheels are massive, the bearing guides are robust, the rack-and-pinion tilting table is a joy. Everything that should be overbuilt, is overbuilt.

The saw has plenty of guts thanks to a 5-horsepower motor, has a 16" resaw capacity, a real monster of a fence and all the niceties you'd expect from a first-class machine: foot brake, rack-and-pinion guide adjustment, quick-release tension, and lots and lots of steel. The sucker weighs 675 pounds.

I doubt this bear will ever be allowed to leave our cave.



GRIZZLY  
■ [grizzly.com](http://grizzly.com) ■ 800-523-4777

## BIG WOOD VISE Classic Vise Screw

We're a bit obsessed with good vise hardware, and we think you should be, too. A good vise makes every operation easier. Good workholding allows you to focus on working instead of pondering, "How am I going to hold that?"

Woodworker Joe Comunale has taken his metalworking skills and machines and used them to make amazing wooden vise screws, something that hasn't been available to purchase for a long time.

Wooden vise screws advance faster than metal ones, never mark your work with grease and hold as tightly as you'd ever need. Comunale's company, BigWoodVise.com, makes wooden vise screws with the fit and finish of a piece of furniture. And they are both a joy to install and use. He offers several versions for different benches, including one with a Shaker-style hub. We installed his Classic Vise Screw on the bench on last month's cover and couldn't be happier.



## FOURTH FIELD *Red Tape*

This winner is from the category of: Why was this not invented before? Yes. Adhesive clear tape printed with an inch scale.

Called Red Tape and invented by a Georgia entrepreneur, this cool product allows you to put a rule almost anywhere, then remove it without hurting the surface below. It's a 55'-long roll of clear adhesive tape with a continuous ruler printed on it in red.

The tape can be stuck to your workbench then removed if you please. It's great to have a ruler stuck to your bench that allows you to quickly ascertain how long or wide a piece is by simply shifting it over the tape.

You can stick the tape to the curved arm bow of a Windsor chair and use it to lay out the spacing of the spindles. Or you can even stick it to your computer monitor to pull dimen-

sions from a photo or use it to size objects in CAD or a photo-editing program.

I used Red Tape on my monitor to pull dimensions off a photograph of a Shaker hanging cupboard. It was very handy and easier than holding a ruler up to the screen or even working from a print-out.

The tape is marked in  $\frac{1}{16}$ ths, repeats every 12" and does not stretch, as far as we can tell. The printing job is quite accurate.

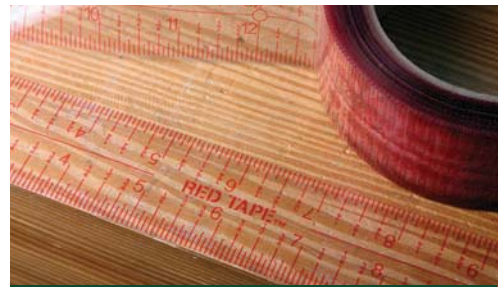

**FOURTH FIELD**  
■ redtape1.com ■ 706-405-5031

## VERITAS *Dovetail Saw*

Veritas shocked a lot of woodworkers when it introduced its new dovetail saw for three reasons:

- It looks modern but feels like a vintage saw in the hand.
- It cuts extremely well.
- It's \$65.

While most premium Western saws are easily \$125 or more, this new Veritas saw opened up the Western saw market to a new range of woodworkers who might have considered buying a Japanese handsaw (or none at all).

Or, even worse, they might have tried to make do with a cheap home-center saw and given up dovetailing altogether.

The Veritas saw is a remarkable combination of old technology and new. The old: the handle shape comes from a vintage saw and it is attached to the saw with a bolt like a handplane tote—very clever. The new: The back of the saw is made



**VERITAS**  
■ leevalley.com ■ 800-871-8158

using stainless steel powder, glass fiber and a polymer resin.

How does it cut? Brilliantly. Thanks to a slightly relaxed rake, the saw starts easily in end grain and is smooth in the cut. The company also makes a fine-tooth version of this saw and a crosscut version. That means you can buy two saws for a bit more than you would spend to purchase a single saw from a competitor.

## MAKITA LS1016L Miter Saw

Here at work, we get to try every brand of miter saw available. And when we go to our shops at home, a lot of us have Makita miter saws waiting for us there.

This year we brought the Makita LS1016L dual-sliding compound miter saw into our shop, and the entire staff has been overjoyed with it. It has guts. Sure, every miter saw says it's a 15-amp tool, but Makita's motors squeeze an astonishing amount of oomph from a wall socket. And the saw features electronic feedback to keep the rpm up under a heavy load.

Also great: This model features four steel rails. Why should you care? Accuracy. Many two-rail saws can deflect. And when mitering, even a little deflection is a disaster.

This saw has great capacity, both vertically (up to 4<sup>3</sup>/<sub>4</sub>" ) and with your work flat on the table (12"). The laser is a nice bonus. And the saw comes with a blade you won't have to replace as soon as you open the box.

Once again, Makita has won our hearts with a world-class miter saw.



## MAKITA BTD144 Impact Driver

Makita cordless drill-drivers have long been a favorite in our shop, and so it was a bit of a surprise when an 18-volt cordless impact driver became an object of envy.

There is a lot to like. It's compact, powerful and capable of great finesse – not something you hear a lot when discussing impact drivers. By pressing a button you can vary the tool's torque to deal with soft, medium or hard materials.

Add to that Makita's reliability, battery technology and a useful task light (that we love) and we knew we had a winner.



## KREG Beaded Face-frame System

There are lots of ways to make mitered beading in a face frame that require expensive machines, some serious hand skills or a master's touch with a table saw.

Now Kreg Tool has invented a way for the rest of us to make these eye-catching frames. If you incorporate beaded face frames into many of your projects (or you are a professional kitchen cabinet maker and want to set yourself apart) this is a clever system to consider.

Here's how it works: Thanks to a special sliding fence you can plunge your stile material straight onto a special notching bit (included with the kit). This bit easily plows out the mitered section in the stile, a cut that many woodworkers struggle to make.

Then you just move the fence's stop, notch the ends of your rails with the same



bit and add your beading. The system is ideal for those who use pocket screws to assemble face frames. **PW**



# Shooting Boards

Small work is safer – and easier – to size with a handplane and shooting board.

I have been a woodworker for 38 years and I still have all my fingers on both hands. My fingers all run out to the very ends, just like when I was born. I don't even have any big scars on my fingertips. Why? I am really wary about getting my precious appendages too close to spinning blades. When the work gets too small for me to be comfortable, I switch to hand tools.

So, when I need to joint small pieces or square them up, I use a shooting board rather than a jointer or table saw. The term “shooting” is archaic. It means to trim and true an edge with a plane. So, a shooting board is a device that allows for controlled trimming of the edges and ends of small pieces of wood with a handplane.

The good news about shooting boards is that you will get perfect results with no

noise. Wait. There's more. I'll bet you're like me. After all these years I still get a kick watching a shaving coming out of a plane. My jointer and table saw do not give me any such enjoyment. Finally, there is almost no risk. If your fingers get too close to the plane, you will lose at most a layer of skin.

A shooting board gives you so much control it is possible to trim almost to the microscopic level. If necessary, you can close up a joint by removing no more than a layer of dust with each pass of the plane. Shooting boards permit a level of adjustment, precision and control beyond the reasonable use of any machine.

There are a number of different shooting boards. Each type is used for a different type of joint. I'll talk about the various shooting boards later.

## The Parts

All shooting boards have three parts in common: the base, the platform and the stop.

The base holds everything together and provides the surface the plane runs on. The base needs to be stable so it stays flat. I recommend either  $\frac{3}{4}$ " luan or birch plywood. Use the plywood's finished side up so your plane runs on the smoothest possible surface.

The base is also the part that is clamped or secured to the benchtop. The easiest way to secure it is to screw a cleat on the bottom. This cleat can be attached in one of two places. It can be placed on the lower back end so that it hooks over the edge of the bench and resists the plane's pushing motion. Another option is to attach a cleat in the middle of the base so the board can

BY MICHAEL DUNBAR



**Common parts.** This “joint-and-square” shooting board shows the three parts common to every iteration: the base, platform and stop.

be secured in a vise. You can also push a shooting board against a bench dog. Which option you use is determined by the function of the shooting board and your personal preference.

The platform is the second part all shooting boards have in common. The platform is a shelf. The work—the part you are trimming—is placed on the platform. This elevates it above the base so the plane’s cutter can engage it. Like the base, the platform needs to be stable. On some shooting boards I also use plywood for the platform. If plywood is not practical, I prefer a stable wood such as white pine. I screw the base and platform together with drywall screws. Countersink the heads. You don’t want them poking up and interfering with your work or damaging your plane.

The stop is the third part. The stop holds the work in place and at the desired angle, relative to the edge of the platform and the plane. The stop is small and has to withstand a lot of force. I use either a hardwood such as maple, or plywood for my stops. I both glue and screw them to the platform. The stop’s business end should be the same angle as the ledge relative to the base. This feature supports the work’s back corner when shooting across grain and minimizes chipping. You can see this detail in the photos of the various boards.

If you need to use a shooting board for just one job, its construction can be really basic. However, I figure if I use something once, I’ll probably use it again some day. So I make my shooting boards to last. They have been used a lot and are showing the wear.

### Types of Boards

The most common shooting board is the “joint and square.” Its purpose is just what its name implies. It is used for jointing the edges of small pieces and squaring their ends. A joint-and-square board is as simple as a base and a flat platform with a hardwood stop secured at a right angle to the platform’s edge.

This simple configuration will hold the work parallel to the base and square to the stop. It works well, but does present a problem when the shooting board is used repeatedly. On such a simple shooting board all the cutting action occurs at the same point on the plane’s cutting edge, over and over and over. Because that spot on the edge gets all the wear, it eventually becomes dull.

Late 19th-century woodworking books illustrated what they referred to as an “improved” shooting board. One of the improvements incorporated in this design addressed the problem of cutting at only one location on the blade. The innovation was to replace the flat platform with a ramp that lifts the work at an angle to the base. The idea is that the cutting action distributes over the plane’s entire blade as it passes along the work.

Besides distributing the wear along the cutting edge, the improved board has another advantage. The ramp causes a

skewed cut. Every hand-tool user knows a blade cuts best when it slices, rather than when pushed directly into the work. That principle does not apply to just wood. It is the reason cavalry swords are curved and guillotine blades are skewed.

The 19th-century improved shooting board also includes a dust groove in the base alongside the platform. The idea is that dust will collect in there and not affect the job. This is important, as it is critical to the shooting board’s results that the plane always lie flat on the base. Chips and other fine debris gathering under the plane’s cheek can lift the tool out of square. On an improved board the



**Dust collection.** The improved joint-and-square board distributes the cutting action across the plane blade’s cutting edge. The dust groove collects any shavings that could lift the plane out of square.



**Perfect miters.** The miter shooting board is used for truing and adjusting miters.





**Donkey's ear.** A 45° donkey's ear is used to trim standing miters and edges. For coopered work, make a board at another angle. The one on the right is 22½° and makes an octagonal form.

dust collects in the groove and from time to time can be cleaned out with a puff of air.

The miter shooting board does what its name implies. It allows you to square up and adjust mitered ends. Its stop is a 45° corner attached to the platform. Both ends of the work usually have mitered ends, and these are usually cut in opposite directions. This placement of the stop allows the board to be used either way. The platform on this board is parallel to the base. While ramping a miter shooting board in both directions is conceivable, I never thought it worth my while to try. I trim a lot fewer miters than I do edges and ends.

If you frequently make parts of a certain angle you can make a board for that specific purpose. For example, if you make octagonal frames, a shooting board with a 22½° corner, rather than 45°, will be helpful.

Standing miters are the joints used on baseboards and bracket feet, although they can also be made on edges for coopered work. A special shooting board called a “donkey's ear” (I have no idea why) trims these joints. On this board the stop is at a right angle but the platform is tipped at 45° to the base.

If you do a lot of coopering, you may want to build a shooting board similar to the donkey's ear with the platform tipped at an angle other than 45°. I have one that shoots edges and ends at 22½°. I use it in conjunction with a miter shooting board of the same angle for making octagonal tea caddies that I give away as presents.

When making a shooting board, scale

it to the size of your work. My boards are about the maximum size I would recommend. I can do both small- and medium-sized work on all of them. Any work too big for my boards I will joint or trim with other techniques. On the other end, very small-scale woodworking, such as model making and inlay making, calls for even smaller shooting boards.

### The Plane

A shooting board is only half the equipment needed for shooting. You also need a handplane. I suggest you dedicate a plane for use on your shooting boards and that you not use it for other work. That way, you do not have to go through the hassle of setting up and sharpening every time you want to shoot an edge. You do not want just any handplane for this purpose. This tool has to be best quality. A hardware store plane will not be satisfactory. I keep a well-maintained Bed Rock 605 just for use on my shooting boards.

Your plane must be fully tuned and sharpened. Make sure your lateral blade-



**Straight edge.** Your plane blade's cutting edge should be straight.

adjustment lever is stiff and requires effort to move. You do not want to inadvertently change the blade setting if you accidentally bump the lever.

A shooting board plane is used for trimming the edges and ends of boards. The rule for a blade's cutting edge is that it is ground straight, unless the plane is used on a surface wider than the blade. This means that unlike a jack or a smooth, your shooting board plane has a straight cutting edge.

I lapped my plane's sole flat to improve its performance so it would take the most precise cut possible. I also lapped the right cheek. I did this so the cheek would be smooth and reduce friction, not to make it dead square to the sole. A perfect 90° edge is created, not by the plane's sole and cheek, but by adjusting the blade laterally. This process is one of trial and error. Take a pass on an edge then check it for square. Adjust the cutter as needed. Continue to adjust until you get a perfectly square edge each time you use the plane. All this fussing reinforces why you want a dedicated plane.

### Setting Up

After making a shooting board, test its accuracy. Joint an edge and square an end. Check the results with a square. For very small work, use a small square. Check a miter with a miter square. If you make a specialty board for another angle, check it with a bevel square set from a protractor.

Adjust your plane's cutter laterally as described above. If this does not work you can make very fine adjustments with a narrow strip of painter's tape.

You will have to work out these adjustments through observation, and trial and error. You can raise the edge slightly with a strip close to the platform's edge. You can



**Tape trick.** You can increase your board's precision by using a strip of painter's tape to lift (as shown) or lower the angle.



**Pencilled guides.** The two circles show where this miter's inner and outer corners have not closed. Plane only in the center of the joint. The pencil lead on the square end has been trimmed to make this joint perfectly square. Note that the area to be trimmed is away from the stop. This avoids the problem of chipping the far corner.

lower the work with a strip more to the middle. You can also apply a strip to the stop to make minor adjustments there. If one strip is insufficient, you can use additional layers.

### Shooting Board Use

Shooting boards have two purposes. The first is truing. This means you use the boards to shoot a perfect joint. Except for small work on the donkey's ear, a shooting board does not actually make the joints. It trues them up after they are cut. Cut the joints as you normally would. You can square an end or cut a miter in a miter box, with your table saw or on a chop saw. Then, shoot the cuts to make them true. When you put the edges or ends together they will fit tightly and at the desired angle.

The second purpose for shooting boards is fitting. Let's face it: No matter how accurate your work, butt joints and miters don't always fall tightly into place. Your joints may be perfect, but the carcass, the base or something else could be just a whisker out of square. The only solution is to trim the joint to make it fit.

It's back to the shooting board to match up the parts by trimming the joint. This process amounts to finagling and requires some decision making. With the joint held together, mark either the high spots or the low spots—the points where the two halves touch, or don't touch. Which you mark is personal preference. To illustrate, I did both in the photo above. In the miter, I have circled the two open corners. On the out-of-square end, I traced a pencil mark. It doesn't matter as long as you remember and understand what you need to do.

Carefully trim just the areas that need trimming, in other words just the high spots. In the case of the pencil line I would remove

the fine line of lead. On the miter I would shave the area between the circles. If the joint does not close completely, I would also shave the same area on the other side of the joint. This should close the gap, or at least make it better. You may have to repeat the operation until the joint closes tightly.

Operations such as squaring ends and trimming miters involve end grain. When truing end grain it is possible to experience chipping of the far corner. Avoid this problem when squaring by flipping the work so the high spot is close to you. If you are truing a miter, or a standing miter, you do not have this option. You just have to be careful. Keep the far corner as close and tight to the stop as possible. In other words, use the stop to support the far corner

When you place the work on a shooting board allow it project as little as possible



**Wax.** Waxing a shooting board with paste wax reduces friction and makes it easier to move the plane.



**Close to stop.** When planing end grain, keep the work as close as possible to the stop. This supports the far corner and helps to avoid chipping.

over the edge of the platform and beyond the stop. Again, this is most important when working end grain. The more the part projects beyond the stop, the greater the chance of chipping. However, when shooting edge grain a minimum of overhang will support the stock. Unless well supported, thin stock can flex while being shot, affecting the joint's accuracy.

While a shooting board itself may be secured by an end cleat or held in a vise, the work is not clamped to the board. Obviously, shooting requires the stock to remain stationary and not move. The solution is in how you hold the stock. When possible I use the stop to anchor my hand. I do this by hooking my fingers over it. I use my other fingers to apply downward pressure. If possible, I hook my thumb over the end of the piece to press it against the stop.

Shooting small parts requires watching the action closely. Shoot joints in good light and keep your face close to the work.

One last tip: When you make a shooting board sand the board's base (the surface where the plane rides). Get it as smooth as possible. Then from time to time, wax this surface with a paste wax. Both steps reduce friction and make it easier to push the plane. Cutting requires force. Shooting is a lot easier if as much force as possible goes into cutting, rather than into moving the plane. **PW**

A chairmaker since 1971, Michael is the founder of The Windsor Institute in Hampton, N.H. ([thewindsorinstitute.com](http://thewindsorinstitute.com)).

# Seamless Curved Panel Glue-ups

BY MARIO RODRIGUEZ



Work with the grain  
when gluing panels,  
even when the grain  
throws you a curve.

*Smooth and steady.* A sharp blade and a smooth, continuous motion will produce a clean, router-ready pattern.

# W

hen I look at a piece of furniture, aside from its design and craftsmanship, I examine how the wood was used. How was it employed to enhance the design and optimize its appearance? Grain, color and species all contribute to its success. However, one aspect that is often overlooked is the harmonious arrangement of the boards that make up the piece's larger panels. These could be the panels contained within a door frame or the piece's top.

Consider the visual appeal of a dining table with a top made of two wide boards instead of one comprised of six or seven narrow boards. The viewer's eye takes in the smooth flow of that expanse, uninterrupted by the jarring sight of multiple seams, abrupt changes in color, and converging grain patterns and lines. Most people would prefer a top made of fewer boards to one that resembles butcher block.

A table, or any piece of furniture, made of fewer individual pieces of wood, creates a calm, harmonious and luxurious effect, while eliminating unnecessary distractions and visual noise.

To a woodworker, wide boards can mean an additional expense because most lumberyards and suppliers charge a premium

for wide material. Or maybe some trees only grow to a certain diameter. So the supply of wood is restricted to narrow boards. How might a woodworker create a harmonious wide panel or top from narrow material?

If you can arrange the seams of boards to run parallel to the grain, a joint will be easier to hide, creating the illusion of a single board. Sometimes it can be as easy as cutting a new edge. And all that's sacrificed is a little wood. But if the grain wanders and curves, simply reorienting the edge won't do the trick.

For this idea to work on a board with meandering grain it would require cutting tight, clean adjoining edges to a curve that follows the grain.

### My Method

Because the desired curves are subtle, not abrupt or severe, I was able to do away with complex, multi-step templates, cut with multiple router bits using offset guide bearings. This technique is much simpler and faster.

I start out by laying the boards alongside one another and turn them over and end-for-end to obtain the most pleasing arrangement. I look for color, similar grain and grain direction. Once I've decided on the order

and position of the boards, I look for surface patterns that complement one another. The flatter the curves, the better.

With chalk or a lumber crayon, I draw a curve directly on the boards to indicate where the joint should fall. When laying out the joint lines, avoid abrupt curves that cut severely across the grain (any cross-grain joint will draw attention). You'll get better results with subtle curves that run lengthwise.

On a 1/4"-thick piece of MDF, draw an outline that roughly follows the grain patterns. Cut the outline on the band saw and shape it to a smooth curve. Now place this master pattern onto the board, running with the grain. Adjust its outline to better follow the grain direction.

This is a crucial part of the process. Here is where you "map out" your joints. Ideally, they will be invisible—completely undetectable. But you'll be pleased with joints that aren't obvious and are maybe even difficult to find. The eye normally moves in a straight line. And joints running in a straight line are easy to locate and follow. But when the seam curves slightly, the eye loses track of it. Joining boards now becomes a little game: See if you can find the seams.



**Nice arrangement.** Rough-cut boards are arranged for the best color and grain match.



**Double duty.** The master pattern lays out a curve common to both boards.



**Pattern repeat.** After fine-tuning the master pattern outline, transfer it onto a wide piece of 1/2" MDF.

## Making Up Your Working Patterns

Center your master pattern on a piece of 12"-wide, 1/2"-thick MDF and transfer the outline. Strive for a single clean, clear line. The next step, band sawing this line, is important because the quality of the cut will directly impact the quality of your joint. The size of the saw you use is unimportant; even a 14" saw will do.

And the size of the blade isn't as critical as its sharpness. I use a 1/4" skip-tooth blade (6 teeth per inch) and obtain great results. Getting a clean working pattern depends on your cutting motion. For the best results, use a continuous and smooth movement when cutting. The cut can't be doctored afterward. What you get off the saw is what will produce your final joint edge.

If your cut wanders off the line a little, don't worry. What's most important is a smooth cut without jogs, blips or bumpy pauses.

After cutting the outline on the band saw, you should have a pair of complementary working patterns. Pressed together, the two halves should produce a perfect and tight fit, without any gaps.

### Perfect match.

When pressed together, the band-sawn halves (of the working pattern) should come together nicely without gaps or unacceptable roughness.

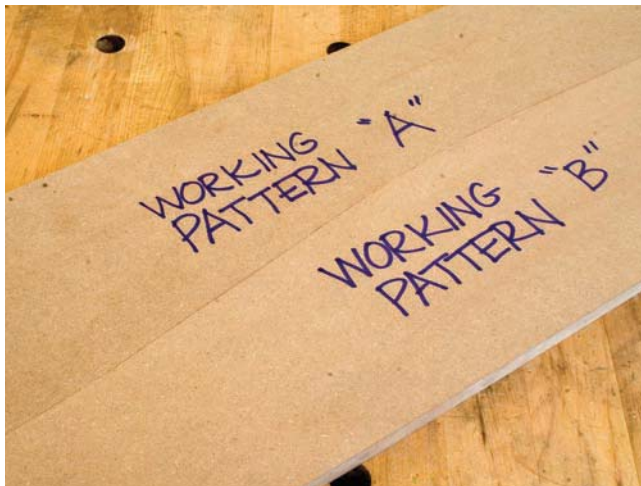

**Ready to go.** Label each side of the pattern to avoid confusion as you work the joints.



**Ready to rout.** The working pattern should be securely attached to the workpiece before routing. In this case, I used double-sided tape.

## Rough Cuts

Carefully align the edge of one working pattern with the straightened edge of your board. On the band saw, cut within  $\frac{1}{8}$ " of the outline. Securely attach the template to the rough-sawn edge of the board with either clamps or double-sided tape. The new rough-sawn edge should be trimmed clean and flush to the working pattern. For the best results, use a  $\frac{3}{4}$ "-diameter flush-trim router bit. The large diameter of the ball-bearing guide will span any small imperfections in the pattern and produce a smooth, flowing curved edge.

When setting up the router, extend the bit to clear the full thickness of your material. Any adjustment to the router bit after you make a cut might produce a stepped edge. The first pass should be light, taking away about half of the waste. The next pass should remove the rest and leave a perfectly smooth edge ready for gluing.

The same operation is repeated on the adjoining board with the complementary working pattern. After both halves have been routed, place them together for inspection. The two routed edges should produce a perfect match.

If your panel contains several boards, prepare all of the joints before gluing any together. Glue up only two boards (or one joint) at a time. If a project requires more than one routed/curved edge, the remaining edges should be protected from damage with shaped and padded cauls.



**Size does matter.** A  $\frac{3}{4}$ "-diameter flush-trim bit is perfect for trimming the workpiece edge flush to the curved pattern.



**Where's the joint?** Two routed edges, joined together, produce a tight, clean and nearly invisible seam.

The completed panels should exhibit grain patterns that are complementary, moving in the same direction. The edge of one board should mimic the edge of the adjoining board. The end result should be a panel that creates a sense of calm and balance, giving the impression that it was made up of fewer boards than it actually was. **PW**

---

*Mario has been a woodworking teacher, author and builder for more than 30 years. He now teaches at the Philadelphia Furniture Workshop, [philadelphiafurnitureworkshop.com](http://philadelphiafurnitureworkshop.com).*



**Careful clamping.** Rubber-padded cauls are used to prevent clamp marks on routed edges.

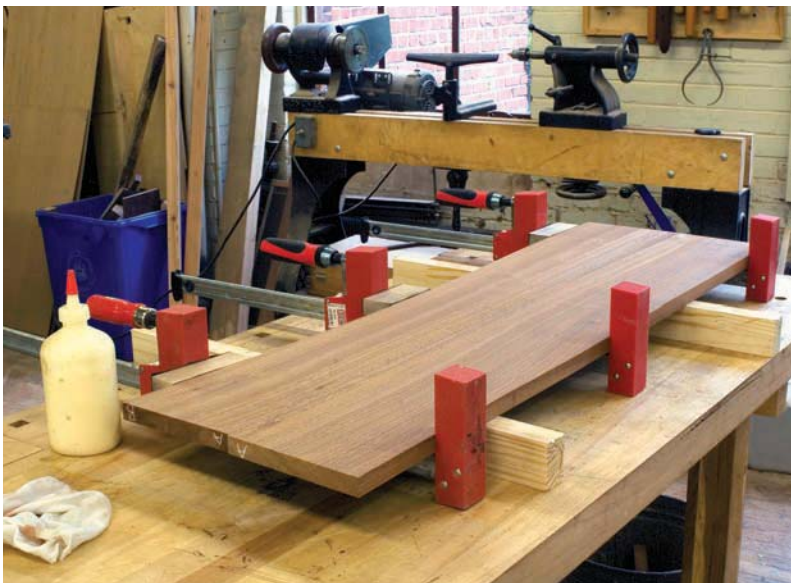

**Patience pays.** Gluing up two boards at a time allows more careful registration and alignment of the joint.



**Unseen seams.** Free from harsh colliding seams and abrupt changes in color, the completed top presents a clean and harmonious panel.

# Coping at the Router Table

Work smart across the grain with a simple push block.

One of the first vehicles I owned was a 1964 Ford Econoline van. I bought it cheap at a police auction then proceeded to over-accessorize it with all manner of mirrors and lights I didn't need. I was young and didn't know any better. It's easy to fall into that kind of trap as you learn something new.

J. C. Whitney saw me coming and took advantage; likewise most new woodworkers are easy prey as they put together their first router table. Miter gauges and miter gauge tracks on router tables are the fuzzy dice and ground-effect lights of the wood-working world.

In the June 2009 issue of *Popular Woodworking* (#176) we featured an easy-to-make and inexpensive router table that does everything you need to do without any frills. In this issue, we show you how to safely make cuts across the grain; the only thing it will cost you is a trip to your scrap bin.

The problem with installing a slot in a router table and using a miter gauge is that it complicates a simple process. To make a cut across the end of a piece of wood, you need a safe and secure way to guide the wood at a right angle to the fence.

A miter gauge riding in a slot will do that, provided that the fence and the slot are perfectly parallel. This fence-to-slot alignment can be time-consuming and tedious to achieve, and if you need to make a small adjustment to the fence, you are likely to lose the parallel setting.

## Don't I Need to Have a Miter Slot?

A square block of plywood or solid wood will serve your purposes, and if the corners are square, the only relationship you need to be concerned with is that between the bit and the fence. Because you'll be working at a right angle to the fence, you don't need to



**Simple enough.** A few scraps of wood provide a safe and effective means of working across the grain on narrow pieces at the router table. You don't need the expense of a miter gauge and a slot for it to ride in, and you don't need the hassle of setting the fence parallel to the slot.

be parallel to anything. A router table has different functions than a table saw.

I used a piece of  $\frac{3}{4}$ "-thick Baltic birch plywood, about  $7\frac{1}{2}$ " square. I double-checked the corners for square and screwed a piece of  $\frac{3}{4}$ "-thick x  $1\frac{1}{2}$ "-wide oak about 4" long to the face of the plywood. I rounded the edges for a comfortable grip, and set the oak at about a  $45^\circ$  angle to the outside corner. A couple #8 x  $1\frac{1}{4}$ " screws hold the handle in place.

I also added a couple strips of  $\frac{1}{2}$ "-thick Baltic birch plywood to the face of the router table's fence to narrow the opening around the bit. I cut the ends at  $45^\circ$  to get them as close as possible to the cutter, then simply

screwed them to the face of the solid-wood fence. The opening between the two halves of the fence should be less than the width of the piece being coped. This ensures that the work is always in contact with the fence as the cut is being made.

In the photos, I'm using the cope cutter from a rail-and-stile set, but these methods can also be used for making tenons using a straight router bit.

## Short Acts as Long

The push block makes a short workpiece (which might twist and get away from you) act like a long workpiece that you can effectively hold against the fence as you cut. It

keeps your hands away from the spinning bit while giving you control of the work.

To make the cut, start well away from the cutter on the infeed side of the fence. Place the coping block against the fence with your right hand on the handle. The angle of the handle will remind you and assist you in applying force toward the fence and across the cutter.

Hold the workpiece against the edge of the push block with your left hand. Slide it up tight against the fence, but as you cut, don't apply pressure against the fence with the workpiece. Direct your effort to holding it tight against the leading edge of the push block as you move it along the fence and across the cutter.

You want to keep the end of your work in contact with the fence, but you don't want to push the leading corner into the cutter. The narrow opening around the cutter is essential to prevent that from happening.

After the workpiece has cleared the cutter, you can slide it out of the way, then pull

the push block back. The router bit will cut into the end of the push block, but that is a good thing. It prevents the router bit from blowing out the grain as the router bit exits the work.

If you're making a tenon in a narrow piece that is longer than the exposed portion of the bit, make the cut in two passes. Keep the end of the workpiece away from the fence during the first pass. This will remove waste

material that would otherwise be between the bit and the fence as you cut with the end of the piece against the fence. This will give you a cleaner shoulder cut, and it will reduce the chances of kickback. **PW**

---

*Bob is senior editor of Popular Woodworking and Woodworking Magazine, and author of "The Complete Kitchen Cabinetmaker," available from his web site: [craftsmanplans.com](http://craftsmanplans.com).*



**Stand back.** Align the work to the push block, and the push block to the fence, well away from the cutter on the infeed side of the fence. Check to see that the parts are tight to the fence and that your hands are in a safe position before you advance the work across the cutter.



**Straight and narrow.** Minimize the opening in the fence around the bit so that some portion of the work will be in contact with the fence at all stages of the cut.



**Follow through.** Push the block and the workpiece until the workpiece is safely beyond the cutter. Slide the workpiece off the table and pull the push block straight back along the fence.



**First things first.** When making a tenon, keep the end of the work away from the fence and remove the waste with the first pass.

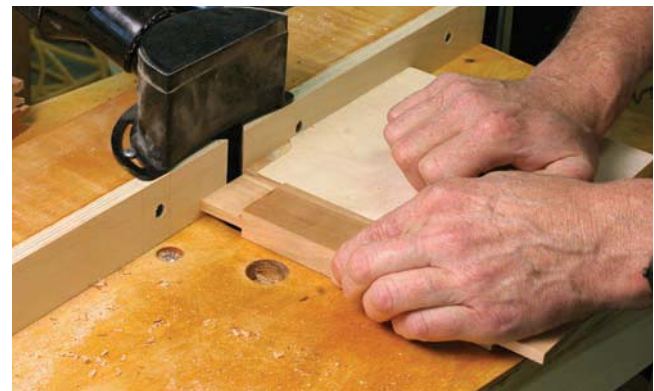

**Move in to finish.** The second pass makes a clean shoulder cut without the chance of material being caught between the bit and the fence.



BY BOB FLEXNER

# Gel Varnish

The (almost) perfect compromise.

Most woodworkers do their finishing with one of two wipe-on/wipe-off finishes: oil/varnish blend or wiping varnish.

Oil/varnish blend is a thinned mixture of boiled linseed oil or tung oil with alkyd or polyurethane varnish. You can buy it commercially (often labeled “Danish oil”) or you can make your own – for example, one part oil, one part varnish and one part mineral spirits.

Wiping varnish is alkyd or polyurethane varnish thinned a quarter to a half with mineral spirits to make the finish easy to wipe on and off the wood. You can buy it commercially (rarely labeled for what it is) or you can make your own by thinning any varnish or polyurethane.

Both finishes are easy to apply and produce near-perfect results. But they differ significantly in sheen and water resistance.

Oil/varnish blend produces a pleasing satin or “rubbed” sheen, but the finish is too thin to be water-resistant. This is because all coats have to be thoroughly wiped off or the finish dries tacky.

Wiping varnish can be left in thicker applications because it dries hard. So it can be built up enough to produce excellent



**Thickness.** Gel varnish is thick in the can, but it spreads easily because of its thixotropic quality.

water resistance. But wiping varnish produces a gloss sheen many woodworkers find objectionable. (Of course, you could always rub the final coat with fine steel wool or other abrasive to lower the sheen, but doing this adds a complication most woodworkers would rather avoid.)

Gel varnish, which is also available as gel

polyurethane, can be thought of as a compromise. It produces an attractive satin sheen similar to an oil/varnish blend but with better water resistance, and it is almost as easy to apply. It also has a very low odor, which makes it especially user-friendly for home workshops.

If you’ve ever applied a gel stain, you’re familiar with gel varnish. It’s exactly the same, just without the pigment colorant.

Gel varnish has been around for decades, but it gets much less attention than the other two finishes and it is often difficult to find. It is sometimes labeled “natural” gel stain when the manufacturer intends it for thinning or reducing the color intensity of its colored gel stains. But it is the same as a gel varnish.

## What is Gel Varnish?

Manufacturers change the consistency of liquid alkyd or polyurethane varnish to that of a gel by incorporating a thixotropic addi-



**Brands.** Here are four brands of gel varnish. Notice that some are polyurethane varnish rather than alkyd varnish and some are packaged in squat cans that make it easier to get to the finish near the bottom with a cloth.

CONTINUED ON PAGE 76

PHOTOS BY THE AUTHOR

tive. You are quite familiar with products that have been made thixotropic. They include ketchup, mayonnaise, many facial creams and salves, and latex wall paint.

All these substances appear thick in their containers. Once on the bread, face or wall, however, they spread easily. This is because thixotropic substances have the added characteristic of responding easily to a shearing force, such as brushing, wiping or spreading. When the shearing stops, the substance returns quickly to its thickened state.

A good example is latex wall paint. The paint appears thick in the can but stirs and pours easily. It also spreads easily under a roller. But as soon as the roller is past any given point on the wall, the paint thickens so that the protruding nibs created by the nap hold their shape and don't run down the wall.

Gel varnish is the same. It appears thick in the can, but it spreads easily. It also retains the ridges left by a brush or cloth, so almost all the excess has to be wiped off after each application.

The thixotropic additive in gel varnishes gives them a satin sheen.

Just as with all varnishes, gel varnishes can be applied over any stain as long as the stain is dry.

### Applying Gel Varnish

Gel varnish applies almost exactly like oil/varnish blend. Wipe or brush the finish on the wood and wipe off the excess before the finish dries.

There are two minor exceptions. Because gel varnish doesn't soak into the wood like oil/varnish blend, there's no reason to continue wetting the surface until the soaking-in stops. In other words, there's no benefit to leaving the finish wet on the surface for any length of time. You can wipe off immediately.

Also, gel varnish dries much faster than oil/varnish blend. So on large surfaces you have to move rapidly. You may even have to divide the object into sections and finish each before moving on, or get a second person to wipe off while you apply. (Bartley's brand dries noticeably faster than the others I've tried.)

You'll learn the drying characteristics of the gel varnish you're using very quickly. But if some dries too hard to wipe off while you're learning, simply remove it within a



**Sheen.** In contrast to the gloss sheen of wiping varnish (applied on the left half of this panel), gel varnish (right half) produces a satin sheen. This is due to the thixotropic additive, which also gives the varnish its thickness and easy spreadability.

short time by wiping with a rag soaked with mineral spirits, then adjust your application method when reapplying the finish.

Just as with any finish, it's important to sand the surface smooth after the first coat (the sealer coat) and after each additional coat unless the surface feels perfectly smooth – that is, no dust nibs. Unless you have an unusually rough surface, use #320- or #400-grit steared sandpaper. The most widely available brands are Norton 3X and 3M Sandblaster.

Gel varnish is almost the perfect compromise between oil/varnish blend and wiping varnish, but not quite. Though a pleasing satin sheen can be achieved in three or four coats, it takes a great many coats to produce a completely water-resistant film. Even though you can usually apply two, and maybe even

three, coats in a day because of the rapid drying (more rapid in warmer temperatures), getting this degree of protection can still take many days and be a lot of work.

So to speed the goal of good water resistance on a critical surface such as a tabletop, apply several coats of wiping varnish and leave most or all of the excess of each to build a thickness. (See “Applying Wiping Varnish” at [popularwoodworking.com/finishing](http://popularwoodworking.com/finishing).) Then follow with one or two coats of gel varnish to get a satin sheen.

Be sure to sand between coats of wiping varnish to remove dust nibs, and rub the last coat before applying the gel varnish with #000 or #0000 steel wool to dull the finish in the pores and other recesses. You can also sand this coat. But the sandpaper won't get in the pores to dull them, so some gloss may show through.

The most difficult surfaces to coat with gel varnish are those with three-dimensional recesses such as inside corners, carvings, turnings and mouldings because of the difficulty getting the finish into, and the excess out of, the hollows. If you are struggling with a cloth, switch to a brush. To remove excess, use the brush dry. A cheap throwaway “chip” brush works well.

Just as with oil/varnish blend, gel varnish is very easy to repair if it gets scratched or damaged. Simply clean the surface, sand out any roughness, then apply another coat. You can use any brand. **PW**

*Bob is author of “Understanding Wood Finishing” and contributing editor to Popular Woodworking.*



**Wiping on.** To apply a gel varnish, simply wipe it on the wood like you would an oil/varnish blend. You can use a brush to help get the thickened varnish into recesses and inside corners, but wiping is much faster on level surfaces. You can wipe in any direction.



**Removing.** Use a cloth to remove the excess gel varnish before it begins to harden, which it does much faster than liquid varnish. To aid in getting the varnish out of recesses and inside corners, use a dry brush as I'm doing here.

BY ETHAN SINCOX

# But Aren't You a Woodworker?

It's not a hobby if it isn't fun.

Last year, my wife and I bought our first house together. Right after closing, with the help of friends, we pulled carpet, painted, moved walls and relocated plumbing. Rooms took on different shapes, the floors gleamed in wide plank hardwood and new ceiling fans quietly circulated fresh air in almost every room.

But the kitchen remained pretty much untouched. We knew our limitations, both in finances and in stamina, and didn't want to bite off more than we could chew. We decided to hold off on its renovation until a later date.

Apparently, that time has come. For the past few months, we've pored over catalogs and design books, trying to figure out what kind of look we want for the new heart of our house. We even got bids from some local stores and talked to a friend about custom cabinets.

And I always get the same look from people when I tell them that.

"You what? But I thought you were a woodworker!"

"Well ... I am."

"Then why don't you make the cabinets yourself and save a ton of money?"

The complete answer to that question is a bit complex, so I usually don't go into great detail. Instead, I smile and nod and mutter something about considering it.

But here is my answer in its entirety.

Woodworking is a hobby for me; I do it because I enjoy it. Wait, let me clarify ... I enjoy the woodworking I do. There is a difference.

I cherish the time I get to spend in my shop, waging the constant battle between my obsessive-compulsive disorder and my art. I don't want to waste that time making things I don't want to make!



I'm a small project kind of woodworker. I make boxes and fuss over little things, such as splined miter joints and fitting compartment inserts. I worry about the Golden Ratio and grain selection, and pairing up my woods for the right amount of contrast and complement. I obsessively ensure the wool tartan linings are perfectly in line with the sides. I even like sanding and finishing.

Making 25 large boxes out of plywood and screws is not my idea of fun. It seems more like work to me. I work at a full-time, non-woodworking job 40-plus hours a week. Woodworking is my escape from the pressures of work.

Last year I attended a seminar taught by Frank Klausz, a master cabinetmaker from Hungary. One of the most important lessons I learned from that class runs through my mind every time I'm in my shop. He said, "Americans try too hard to be good at everything. You want to make cabinets, you want to build furniture, you want to turn bowls and carve faces. In trying to learn a little

about everything, you become masters of nothing."

I tend to agree with him. I don't want to be OK at woodturning and get by with my cabinetmaking skills and not do a half-bad job at carving – then as a result make only mediocre boxes.

I want to make really good boxes. And, eventually, I want to make great boxes. I want people to wonder whether the best part of their gift is the object in the box or the box itself.

Some day, I'll make a box for my wife. It will be made with great consideration and attention to detail. It might have dovetails or it might have splined miters. The dividers will be fitted with precision and the woods will be selected with care. Hopefully, every time she opens it she'll be reminded of just how much I love her.

But it won't hold pots and pans. **PW**

*Ethan works in software support and edits the St. Louis Woodworkers Guild's newsletter. You can read more by Ethan on his blog at [greystonegreen.blogspot.com](http://greystonegreen.blogspot.com).*