

7 Techniques to Soup Up Your Sawing Savvy

# POPULAR Woodworking MAGAZINE

DECEMBER 2010 ■ #187

## Line & Berry Chest of Drawers

Stop Scratching It!  
Use a Router for  
Traditional Inlay

Build a Dirt-cheap  
Twin-screw Vise to  
Make Sawing Easy

Design Tricks to  
Shape Up Your  
Ugly, Chunky Legs

5 Clever Ways to  
Defeat Cross-grain  
Splits in Your Work



Free Video Tour of this 1740s Pennsylvania Piece: Visit [popularwoodworking.com/dec10](http://popularwoodworking.com/dec10)

twmedia US \$5.99

12



0 74470 01355 6

Display until January 10, 2011

[popularwoodworking.com](http://popularwoodworking.com)



downloaded from [www.cro-wood.com](http://www.cro-wood.com)





# Grizzly Industrial

PURVEYORS OF FINE MACHINERY®, SINCE 1983!

- OVER A MILLION SQUARE FEET PACKED TO THE RAFTERS WITH MACHINERY & TOOLS
- 2 OVERSEAS QUALITY CONTROL OFFICES STAFFED WITH QUALIFIED GRIZZLY ENGINEERS
- HUGE PARTS FACILITY WITH OVER 1 MILLION PARTS IN STOCK AT ALL TIMES
- TRAINED SERVICE TECHNICIANS AT ALL 3 LOCATIONS
- MOST ORDERS SHIPPED THE SAME DAY • 24 HOUR ORDERING BY PHONE OR ONLINE

## 10" Left Tilting Super Heavy-Duty Table Saw with Riving Knife

- Motor: 3 HP, 220V, single-phase, 3450 RPM
- Precision ground solid cast iron table
- Table size with extension wings: 40" x 27"
- Arbor: 5/8" • Max. dado width: 7/8"
- Cutting capacity: 8" L, 26" R
- Max. depth of cut: 3" @ 90°, 2 1/8" @ 45°
- Approx. shipping weight: 514 lbs.

**New!**



SHOP FOX® CLASSIC FENCE

G1023RL

INTRODUCTORY PRICE

ONLY \$1125<sup>00</sup>

\$89 shipping ANYWHERE IN LOWER 48 STATES

## 12" Left-Tilting Extreme Series® Table Saw with Riving Knife Feature

- Motor: 5 HP, 220V, single-phase
- Table size with extension: 30 3/4" x 48 3/8"
- Arbor speed: 3600 RPM
- Arbor: 5/8" & 1"
- Max. dado width: 3/4"
- Max. rip capacity: 36"
- Max. depth of cut: 4" @ 90°, 2 3/4" @ 45°
- Approx. shipping weight: 756 lbs.

FEATURES DIGITAL BEVEL ANGLE READOUT INCLUDES 12" BLADE



G0696X \$1995.00

SALE \$1895<sup>00</sup>

\$169 shipping ANYWHERE IN LOWER 48 STATES

## 20" Planers

- Motor: 5 HP, 220V, single-phase
- Table size: 20" x 25 3/4" (20" x 55 1/2" with extension)
- Max. stock thickness: 8"
- Min. stock thickness: 3/16"
- Min. stock length: 7 1/2"
- Max. cutting depth: 1/8"
- Cutterhead speed: 5000 RPM
- Feed rate: 16 & 20 FPM
- Approx. shipping weight: 920 lbs.

PRECISION GROUND CAST IRON BED & INFEEED OUTFEED TABLES



BUILT IN MOBILE BASE

G0454 \$1495.00

SALE \$1395<sup>00</sup>

G0454Z WITH SPIRAL CUTTERHEAD

\$2295.00 SALE \$2195<sup>00</sup>

\$169 shipping ANYWHERE IN LOWER 48 STATES

## 6" Jointers with Mobile Base

- Motor: 1 HP, 110V or 1 1/2 HP, 110V/220V, single-phase
- Precision ground cast iron table size: 7 1/2" x 46"
- Max. depth of cut: 1/8"
- Rabbeting capacity: 1/2"
- Cutterhead diameter: 2 1/2"
- Cutterhead speed: 4800 RPM
- Approx. shipping weight: 270 lbs.

FREE SAFETY PUSH BLOCKS



BUILT IN MOBILE BASE

G0452 1 HP MOTOR \$425.00

SALE \$395<sup>00</sup>

G0452Z 1 1/2 HP WITH SPIRAL CUTTERHEAD

\$675.00 SALE \$650<sup>00</sup>

\$69 shipping ANYWHERE IN LOWER 48 STATES

## 8" x 76" Parallelogram Jointers

- Motor: 3 HP, 220V, single-phase, TEFC, 3450 RPM
- Precision ground cast iron table size: 8" x 76 1/8"
- Cutterhead speed: 5350 RPM • Cutterhead dia.: 3 1/16"
- Deluxe cast iron fence: 36" L x 1 1/4" W x 5" H
- Max. rabbeting depth: 1/2"
- Approx. shipping weight: 597 lbs.



G0490X SPIRAL CUTTERHEAD



BUILT IN MOBILE BASE

FREE SAFETY PUSH BLOCKS

G0490 \$895.00 SALE \$825<sup>00</sup>

G0490X WITH SPIRAL CUTTERHEAD

\$1195.00 SALE \$1095<sup>00</sup>

\$139 shipping ANYWHERE IN LOWER 48 STATES

## 12" x 83 1/2" Parallelogram Jointers

- Motor: 3 HP, 220V, single-phase
- Precision ground cast iron table size: 12 3/4" x 83 1/2"
- Cutterhead speed: 4950 RPM
- Max. depth of cut: 1/8"
- Max. rabbeting capacity: 3/4"
- Approx. shipping weight: 1059 lbs.

PEDESTAL MOUNTED MAGNETIC SAFETY SWITCH



FREE SAFETY PUSH BLOCKS

HANDLES FOLD IN FOR ADDED SAFETY

G0609 \$1895.00 SALE \$1795<sup>00</sup>

G0609X WITH SPIRAL CUTTERHEAD

\$2250.00 SALE \$2195<sup>00</sup>

\$250 shipping ANYWHERE IN LOWER 48 STATES

## 12" Baby Drum Sander

- Sanding motor: 1 1/2 HP, 110V, single-phase
- Conveyor motor: 1/8 HP, 110V, single-phase, variable speed 5-35 FPM
- Drum surface speed: 2127 FPM
- Max. stock dimensions: 12" wide x 3 1/2" thick
- Min. stock length: 8"
- Sanding drum: 4"
- Sanding belt: 3" hook & loop
- Dust collection port: 2 1/2"
- Approx. shipping weight: 160 lbs.



G0459 \$695.00

SALE \$525<sup>00</sup>

\$69 shipping ANYWHERE IN LOWER 48 STATES

## 17" Heavy-Duty Extreme Series® Bandsaw with Cast Iron Wheels & Trunnion

MADE IN ISO 9001 FACTORY!

- Motor: 2 HP, 110V/220V, single-phase, TEFC
- Precision ground cast iron table size: 23 5/8" x 17 1/4"
- Table tilt: 5° left, 45° right
- Max. cutting height: 12"
- Blade size: 13 1/2" L (1/8" - 1" W)
- 2 blade speeds: 1700 & 3500 FPM
- Approx. shipping weight: 418 lbs.

Product Reviews & Awards ONLINE grizzly.com EXTREME SERIES

DELUXE RESAW FENCE & MITER GAUGE



G0513X2 \$995.00

SALE \$895<sup>00</sup>

\$89 shipping ANYWHERE IN LOWER 48 STATES

## 19" Heavy-Duty Extreme Series® Bandsaw

- Motor: 3 HP, 220V, single-phase, TEFC, 1725 RPM
- Precision ground cast iron table size: 26 3/4" x 19"
- Table tilt: 5° L, 45° R
- Max. cutting height: 12"
- Cutting capacity/throat: 18 1/4"
- Blade size: 143" L (1/8" - 1 1/4" W)
- Blade speeds: 1700 & 3500 FPM
- Approx. shipping weight: 480 lbs.

GEARED TABLE TILT MECHANISM

HEAVY-DUTY CAST IRON FENCE & CAST IRON TABLE TRUNNIONS!

EXTREME SERIES

MADE IN ISO 9001 FACTORY!



G0514X2 \$1395.00

SALE \$1295<sup>00</sup>

\$89 shipping ANYWHERE IN LOWER 48 STATES

PRICING CODE 10POP

MENTION THIS CODE WHEN PLACING YOUR ORDER

# 1-800-523-4777

3 GREAT SHOWROOMS! BELLINGHAM, WA • MUNCY, PA • SPRINGFIELD, MO

TECHNICAL SERVICE: 570-546-9663 FAX: 800-438-5901

12991





# HOLIDAY SALE

PRICES VALID November 1st - DECEMBER 31st  
PLEASE VISIT GRIZZLY.COM TO SEE ALL SALE SPECIALS



## 10" Cabinet Table Saws with Riving Knife

- Motor: 3 HP, 220V, single-phase
- Table size with extension:  
G0690 - 27" x 40"  
G0691 - 27" x 74 3/4"
- Blade tilt: left
- Arbor: 5/8"
- Arbor speed: 4300 RPM
- Max. dado width: 1 3/16"
- Max. rip capacity:  
G0690 - 29 1/2", G0691 - 50"
- Max. depth of cut:  
3 1/8" @ 90°, 2 3/16" @ 45°
- Approx. shipping weight:  
G0690-542 lbs. G0691-572 lbs.

**3 HP LEESON® MOTOR!**



CAST IRON TRUNNIONS



Sliding Table & Router Attachments For G0690 & G0691 Table Saws

FREE 10" CARBIDE TIPPED BLADE!

**New!**



SUPERB QUALITY!

SAW NOT INCLUDED

TO GET COMPLETE SPECS AND FEATURES GO TO GRIZZLY.COM®

ROUTER TABLE ATTACHMENT

T10222 \$395.00

SALE \$375.00

SLIDING TABLE ATTACHMENT

T10223 \$550.00

SALE \$525.00

G0690 \$1250.00

SALE \$1150.00

\$139 shipping AMERICAN MADE IN LOWER 48 STATES

G0691 WITH EXTENSION RAILS \$1350.00

SALE \$1250.00

\$139 shipping AMERICAN MADE IN LOWER 48 STATES

## Cyclone Dust Collector

- Motor: 1 1/2 HP, 110V/220V, single phase, TEFC, 3450 RPM, prewired 110V
- Air suction capacity: 775 CFM
- Static pressure at rated CFM: 1.08"
- Intake port: 6" with included 5" optional port
- Impeller: 13 1/2"
- Cartridge filter surface area: 6975 sq. in.
- Overall dimensions: 38 1/4" W x 23 1/4" D x 68 1/2" H
- Approx. shipping weight: 210 lbs.



**New!**

COLLECTION DRUM IS MOUNTED ON CASTERS FOR EASY DUST REMOVAL

THE POWER OF A 2 STAGE CYCLONE IN A NEW COMPACT SIZE!

G0703 \$850.00 SALE \$795.00

\$69 shipping AMERICAN MADE IN LOWER 48 STATES

# POLAR BEAR SERIES™

CELEBRATE THE SEASON WITH NEW DAZZLING WHITE MACHINES OF THE SAME QUALITY AS OUR REGULAR GRIZZLY VERSIONS!



G0459P  
12" BABY DRUM SANDER  
INTRODUCTORY PRICE  
\$528.00

**New!**

\$69 shipping AMERICAN MADE IN LOWER 48 STATES



G0715P  
10" HYBRID TABLE SAW WITH RIVING KNIFE  
INTRODUCTORY PRICE  
\$758.00

**New!**

\$89 shipping AMERICAN MADE IN LOWER 48 STATES



G0452P  
6" JOINTER WITH BUILT-IN MOBILE BASE  
INTRODUCTORY PRICE  
\$398.00

**New!**

\$69 shipping AMERICAN MADE IN LOWER 48 STATES



G0453P  
15" PLANER  
INTRODUCTORY PRICE  
\$898.00

**New!**

\$139 shipping AMERICAN MADE IN LOWER 48 STATES

BOTH MODELS HAVE BUILT-IN MOBILE BASE

G0453PX  
15" PLANER WITH SPIRAL CUTTERHEAD  
INTRODUCTORY PRICE  
\$1398.00

\$139 shipping AMERICAN MADE IN LOWER 48 STATES



G1035P  
1 1/2 HP SHAPER  
INTRODUCTORY PRICE  
\$498.00  
(SHOWN WITH OPTIONAL WING)

**New!**

\$69 shipping AMERICAN MADE IN LOWER 48 STATES

**New!**

G0555P  
ULTIMATE 14" BANDSAW  
INTRODUCTORY PRICE  
\$398.00

\$69 shipping AMERICAN MADE IN LOWER 48 STATES



G0513P  
17" HEAVY-DUTY BANDSAW  
INTRODUCTORY PRICE  
\$698.00

**New!**

\$89 shipping AMERICAN MADE IN LOWER 48 STATES



G0656PX  
8" JOINTER WITH SPIRAL CUTTERHEAD  
INTRODUCTORY PRICE  
\$998.00

**New!**

\$139 shipping AMERICAN MADE IN LOWER 48 STATES

BOTH MODELS HAVE BUILT-IN MOBILE BASE

MORE DETAILS ON THESE EXCITING NEW POLAR BEAR SERIES™ MACHINES AT GRIZZLY.COM®



FREE 2010 FULL COLOR CATALOG!

grizzly.com®

OVER 12,000 PRODUCTS ONLINE!



For more information, go to PWFREEINFO.COM.

# WOODCRAFT<sup>®</sup>

For A Free Catalog Or To Find Your Local Woodcraft Store, Visit [woodcraft.com](http://woodcraft.com) Or Call 800-225-1153.

## Smart Tools From FESTOOL

Check out this Festool combo that will make your woodworking a lot easier and more comfortable!

### TS 55 EQ Plunge Cut Saw With Rail

This saw redefines standards for circular saws by combining its predecessor's remarkable features with new ones like the FastFix system that makes blade changing fast and easy and a retractable spring-loaded riving knife for easier cuts in the middle of a workpiece. Team the TS 55 with a rail system for easy installation of laminate flooring systems and for clean, chip-free cuts in veneered plywood and similar materials.

### CT 26 HEPA Dust Extractor

This 28.7-lb. dust buster is equipped with tool-triggered auto start capability that lets the vacuum cycle with your tool, resulting in more efficient dust collection, reduced noise, and less energy consumption than a "constant-on" unit. Another plus: a self-cleaning bag that prevents dust from caking inside the bag which reduces suction.



**FESTOOL**

#### TS 55 EQ Plunge Cut Saw With Rail - 561174

- 6¼" Dia., 48-Tooth Carbide Tipped Blade
- 55" Guide Rail
- Cutting Depth On Guide Rail: 1<sup>15</sup>/<sub>16</sub>" Cut At 90°; 1<sup>7</sup>/<sub>16</sub>" Cut At 45°
- 3 Bearing Motor For Smoother Operation
- Limit Stop & Chip Deflector
- Rotating Dust Port To Manage Hose

## FESTOOL PACKAGE

*Deal*

TS 55 EQ Plunge Cut Saw  
With Rail &  
CT 26 HEPA Dust Extractor  
#26561174

Reg. \$1,050  
Sale \$995

Prices Valid Through December 31, 2010



#### CT 26 HEPA Dust Extractor - 583492

- HEPA Filter Surface Area: 3.29 ft.2
- 6.9 Gallon (26 L) Container Capacity
- Maximum Suction Force - 137 CFM
- Tool- Or Manual-Activated Startup
- Designed To Navigate Rough Terrain Inside Or Outside
- Works Wet Or Dry

10PW12P

**QUALITY WOODWORKING TOOLS • SUPPLIES • ADVICE<sup>®</sup>**

For more information, go to [PWFREEINFO.COM](http://PWFREEINFO.COM).





42



52



54

## FEATURES

## 32 Line & Berry Chest of Drawers

The inlay design on this traditional Chester County, Pa., piece is made simpler and faster with router patterns and a good straight bit.

BY GLEN D. HUEY

### ONLINE ► Spice Box Door Inlay

A router helped Glen make quick work of the door inlay on his spice box in 2001-2002. You can read the story for free on our web site. [popularwoodworking.com/dec10](http://popularwoodworking.com/dec10)

## 42 Cross-grain Solutions

Learn several methods for defeating cross-grain splits in traditional solid wood construction.

BY ALAN TURNER

### ONLINE ► SAPFM

Discover a wealth of knowledge at the Society of American Period Furniture Makers web site. [popularwoodworking.com/dec10](http://popularwoodworking.com/dec10)

## 46 English Layout Square

This useful tool is easy to make, easy on the eyes and awesome to use.

BY CHRISTOPHER SCHWARZ

### ONLINE ► SketchUp Drawing

Download the free SketchUp drawing for this useful layout tool. [popularwoodworking.com/dec10](http://popularwoodworking.com/dec10)

## 48 Simple Patterns In Veneer

In part three of this series, Marc shows you how to match a panel in veneer using only mirrors, a cheap knife and a straightedge.

BY MARC ADAMS

### ONLINE ► Veneer Mill Video

Take a visit to a veneer mill with the author. [popularwoodworking.com/dec10](http://popularwoodworking.com/dec10)

## 52 Greene & Greene Frame

Details shaped by hand and eye help to define the style of this iconic offshoot of Arts & Crafts.

BY ROBERT W. LANG

### ONLINE ► Punches

The new punches used to create the pillowed plugs typically found in Greene & Greene work are clever. Read a review and see them in action. [popularwoodworking.com/dec10](http://popularwoodworking.com/dec10)

## 54 Furniture's Battle Scars

In this second part of his "Aging Furniture" story, Michael shows you how to create a convincing story of "incidental" wear on your newly built piece of furniture.

BY MICHAEL DUNBAR

### ONLINE ► A Week in New Hampshire

Read about Editor Christopher Schwarz's "sackback class" at Michael Dunbar's New Hampshire school, The Windsor Institute. [popularwoodworking.com/dec10](http://popularwoodworking.com/dec10)

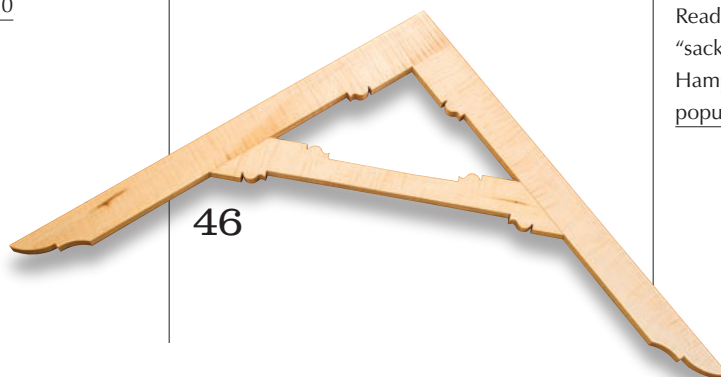

46

# Any Job



Cut Grind Sand Scrape

**Flexibility & Quality** Oscillating multi-tools are versatile enough for almost any job, but it's choosing the right accessories that make the difference. Bosch offers dozens of multi-tool accessories with the best price for the performance.

Available at quality distributors near you.



**BOSCH**  
Invented for life

## Is finding the right accessories for your **multi-tool** driving you crazy?

boschjoethepro.com

TIP #  
**12**



**JOE**  
THE PRO

The oscillating multi-tool is one of my favorites because of its versatility to cut, grind, sand and scrape. Now there are more multi-tools and accessories out there than ever.

I use multi-tool accessories with OIS™ (Oscillating Interface System). OIS is a unique 12-pin system created by Bosch that provides a secure, reliable connection between the tool and the accessory. That's important, especially with today's high-torque oscillating multi-tools. This prevents shearing and gets the job done faster compared to other systems that have four, five or nine points of contact.

But don't just take my word for it. I heard from Rob Estoll, the owner of Tried and True Services in Chicagoland. The Bosch scraper blade saved him hours of time vs. a hand scraper or a random orbital sander when removing paint. He also likes the new diamond grit blade for grout removal which is not only 40% faster, but lasts twice as long and costs half as much as another popular brand of multi-tool accessories.

There is still one thing that drives me crazy. While OIS is available on tools from Bosch, Skil® and Milwaukee®, there are also a lot of multi-tools with different interface systems. Each brand has its own accessories, and not all of them will fit other multi-tools. Sometimes they're pretty hard to find and can be expensive. I don't have time to run around or wait for a mail order to get my multi-tool accessories.



The Bosch OIS™ adapter easily fits all oscillating multi-tools.

What's great is that there is now a universal OIS adapter from Bosch that allows all OIS accessories to work with every multi-tool out there. So now OIS accessories work on Fein®, Craftsman®, Dremel®, Rockwell®, Masterforce® and other tools, plus they're easy to find in a number of stores across the country.

Bosch has a good track record in providing industry standard interfaces that increase performance. They invented the T-Shank for jig saw blades and the SDS shank system for concrete and masonry bits. Every major manufacturer uses these systems. Now regardless of which multi-tool I have, I can use a wide variety of high-quality OIS oscillating multi-tool accessories from Bosch to save time, money and effort. **Better Accessories. Better Results.**

OIS is a trademark of Robert Bosch Tool Corporation. Lowe's and the gable design are registered trademarks of LF, LLC and Let's Build Something Together is a trademark of LF, LLC. The Home Depot is a registered trademark of Homer TLC, Inc. All other trademarks and registered trademarks are the property of their respective owners.

For more information, go to [PWFREEINFO.COM](http://PWFREEINFO.COM).

# Any Tool



Bosch  
Skil®  
Ridgid®  
Milwaukee®  
Fein® 636



OIS™ Adapter

Fein® 250  
Craftsman®  
Rockwell®  
Dremel®  
Masterforce®

## Free OIS Adapter & Bosch Cutting Blade

Go to [boschjoethepro.com](http://boschjoethepro.com) and sign up today!  
Enter code: OISPW10  
Offer expires December 31, 2010

**Best Fit for All Multi-Tools** The new Bosch OIS™ system provides a 12-pin connection, optimizing performance for today's high torque oscillating multi-tools. OIS is the interface of choice on several tools. With the universal OIS adapter, Bosch accessories work on any multi-tool.



**BOSCH**  
Invented for life



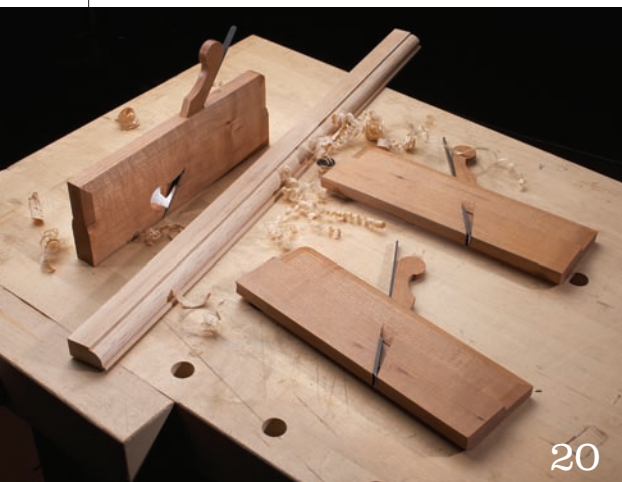

20



28



64

REGULARS

**10** What I Learned At Woodworking In America

ON THE LEVEL

BY CHRISTOPHER SCHWARZ

**12** Sagging Face Vise Screw Concerns

LETTERS

FROM OUR READERS

**16** Auxiliary Band Saw Table

TRICKS OF THE TRADE

FROM OUR READERS

**VIDEO** ▶ Tricks-in-Action

Watch a video of one of our tricks at work.

[popularwoodworking.com/tricks](http://popularwoodworking.com/tricks)

**20** Bickford Moulding Planes

TOOL TEST

BY THE EDITORS

**ONLINE** ▶ Tool Test Archives

We have lots of tool reviews on our web site, free.

[popularwoodworking.com/tools](http://popularwoodworking.com/tools)

**26** Great Legs

DESIGN MATTERS

BY GEORGE R. WALKER

**28** Soup up Your Sawing Savvy

ARTS & MYSTERIES

BY BOB ROZAIESKI

**30** Victorian Side Table

I CAN DO THAT

BY MEGAN FITZPATRICK



30

**60** Staining Wood

FLEXNER ON FINISHING

BY BOB FLEXNER

**64** Moxon's Ingenious Bench Vise

JIG JOURNAL

BY CHRISTOPHER SCHWARZ

**70** Glossary

TERMS OF THE TRADE

Woodworking's terminology can be overwhelming. Learn the terms used in this issue.

**72** Too Delicate A Touch

END GRAIN

BY BRAD GRAHAM

POPULAR  
**Woodworking**  
MAGAZINE

Number 167, December 2010. *Popular Woodworking Magazine* (ISSN 0884-8823, USPS 752-250) is published 7 times a year, February, April, June, August, October, November and December, which may include an occasional special, combined or expanded issue that may count as two issues, by F+W Media, Inc. Editorial and advertising offices are located at 4700 E. Galbraith Road, Cincinnati, Ohio 45236. Unsolicited manuscripts, photographs and artwork should include ample postage on a self-addressed, stamped envelope (SASE); otherwise they will not be returned. Subscription rates: A year's subscription (7 issues) is \$24.95; outside of the U.S. add \$7/year • Canada Publications Mail Agreement No. 40025316. Canadian return address: 2835 Kew Drive, Windsor, ON N8T 3B7 • Copyright 2010 by *Popular Woodworking Magazine*. Periodicals postage paid at Cincinnati, Ohio, and additional mailing offices. Postmaster: Send all address changes to *Popular Woodworking Magazine*, P.O. Box 420235, Palm Coast, FL 32142-0235 Canada GST Reg. # R122594716 • Produced and printed in the U.S.A.

# The facts are hard to ignore.

Titebond® III outperforms polyurethane glues.



Reference Guide

### Glue comparison

What woodworkers need to know!

	Titebond III	Polyurethane Glues
Higher Bond Strength	✓	✓
Exterior Use - Waterproof	✓	
Easy Water Cleanup	✓	
Much Safer To Use	✓	
Shorter Clamp Time	✓	
No Foam - Less Mess	✓	
Shorter Open Time	✓	✓
Doesn't Stain Skin	✓	✓
Bonds Most Materials	✓	
Bonds Oily / Exotic Woods	✓	
Lower Cost - Better Value	✓	
Longer Usable Shelf Life	✓	

Woodworking Handbook 2007

As the leader in wood glues, we want you to know the truth about polyurethane glue and woodworking. A straightforward comparison between Titebond® III Ultimate Wood Glue and polyurethane glue tells the story.

Titebond® III is THE ultimate choice for bonding wood to wood. Period.

For more information and a detailed comparison, please visit [www.titebond.com/TBIIIvsPolyurethane](http://www.titebond.com/TBIIIvsPolyurethane)

Made in the USA

For more information, go to [PWFREEINFO.COM](http://PWFREEINFO.COM).



# C O N T R I B U T O R S



## Bob Rozaieski

“Soup Up Your Sawing Savvy,” page 28.

Bob Rozaieski has been an amateur woodworker since 1991. He is primarily self-taught, learning from books about tools, furniture and furniture making, and time spent in the shop experimenting. Bob gave up all of his power tools about 10 years ago and elected to instead focus on learning about traditional woodworking by working only with hand tools. In addition to working completely by hand, he enjoys the process of designing custom pieces. His primary interest is 18th-century American and Shaker furniture.

Bob is a member of the Society of American Period Furniture Makers and hosts the Logan Cabinet Shoppe blog and video podcast; both are available at [logancabinetshoppe.com](http://logancabinetshoppe.com).

► *Bob welcomes your comments and period furniture questions. E-mail him at [bob@logancabinetshoppe.com](mailto:bob@logancabinetshoppe.com).*



## Alan Turner

“Cross-grain Solutions,” page 42.

Alan Turner was introduced by his father to woodworking at the age of 6, in their home shop. For a long time, he pursued the craft as an amateur, but once his family members’ homes were filled with his pieces, Alan decided to pursue a career as a studio furniture maker. He’s been working wood for more than 50 years, and is an owner and operator of the Philadelphia Furniture Workshop where he designs and builds his pieces, and offers both group classes and private instruction.

In addition to his success as a furniture maker and woodworking educator, Alan enjoyed a long career as a lawyer (a profession from which he’s now mostly retired). He earned his law degree at Rutgers, in Camden, N.J.

► *To read more about Alan and to see pictures of his work, visit [alanturnerfurnituremaker.com](http://alanturnerfurnituremaker.com).*



## Christopher Schwarz

“English Layout Square,” page 46.

Christopher Schwarz studied journalism and worked for various newspapers before joining the *Popular Woodworking Magazine* staff. He was named editor in 2005.

Though he began his journalism career covering trailer fires and political meetings, he’s always been interested in woodworking, and began delving deeply into hand-tool use in 1999 when he was managing editor of this magazine. Since then, Chris has become known not only for his hand-tool skills and knowledge, but for his abiding interest in workbenches. He built his first bench at age 8 – and has built many more since. After writing “Workbenches: From Design & Theory to Construction & Use” in 2007, Chris decided he had more to say on the subject, so he’s just finished “The Workbench Design Book” (Popular Woodworking).

► *To read more from Chris, bookmark his blog at [popularwoodworking.com/chrisblog](http://popularwoodworking.com/chrisblog), where he writes almost every weekday.*

DECEMBER 2010, VOL. 30, NO. 7

[popularwoodworking.com](http://popularwoodworking.com)

EDITORIAL OFFICES 513-531-2690

PUBLISHER & GROUP EDITORIAL  
DIRECTOR ■ Steve Shanesy  
[steve.shanesy@fwmedia.com](mailto:steve.shanesy@fwmedia.com), x11238

EDITOR ■ Christopher Schwarz  
[chris.schwarz@fwmedia.com](mailto:chris.schwarz@fwmedia.com), x11407

SENIOR ART DIRECTOR ■ Linda Watts  
[linda.watts@fwmedia.com](mailto:linda.watts@fwmedia.com), x11396

EXECUTIVE EDITOR ■ Robert W. Lang  
[robert.lang@fwmedia.com](mailto:robert.lang@fwmedia.com), x11327

SENIOR EDITOR ■ Glen D. Huey  
[glen.huey@fwmedia.com](mailto:glen.huey@fwmedia.com), x11293

MANAGING EDITOR ■ Megan Fitzpatrick  
[megan.fitzpatrick@fwmedia.com](mailto:megan.fitzpatrick@fwmedia.com), x11348

ASSOCIATE EDITOR FOR THE WEB ■ Drew DePenning  
[drew.depenning@fwmedia.com](mailto:drew.depenning@fwmedia.com), x11008

PHOTOGRAPHER ■ Al Parrish

F+W MEDIA, INC.

CHAIRMAN & CEO ■ David Nussbaum

CFO ■ James Ogle

PRESIDENT ■ Sara E. Domville

EXECUTIVE VICE PRESIDENT, eMEDIA ■ Chad Phelps

SENIOR VICE PRESIDENT, OPERATIONS ■ Phil Graham

IT DIRECTOR ■ Jim Kuster

EVENTS DIRECTOR ■ Cory Smith

ADVERTISING

SENIOR VICE PRESIDENT, ADVERTISING SALES ■ David Shiba  
TEL. 513-426-2860

[david.shiba@fwmedia.com](mailto:david.shiba@fwmedia.com)

ADVERTISING DIRECTOR ■ Don Schroder

331 N. Arch St., Allentown, PA 18104

TEL. 610-821-4425; FAX. 610-821-7884

[d.schroder@verizon.net](mailto:d.schroder@verizon.net)

ADVERTISING SALES COORDINATOR ■ Connie Kostrzewa

TEL. 715-445-4612 x13883

[connie.kostrzewa@fwmedia.com](mailto:connie.kostrzewa@fwmedia.com)

SUBSCRIPTION SERVICES: Subscription inquiries, orders and address changes can be made at [popularwoodworking.com](http://popularwoodworking.com) (click on “Customer Service”). Or by mail: *Popular Woodworking Magazine*, P.O. Box 420235, Palm Coast, FL 32142-0235. Or call 386-246-3369. Include your address with all inquiries. Allow 6 to 8 weeks for delivery.

NEWSSTAND DISTRIBUTION: Curtis Circulation Co., 730 River Road, New Milford, NJ 07646. PHONE: 201-634-7400. FAX: 201-634-7499.

BACK ISSUES are available. Call 800-258-0929 for pricing or visit [popularwoodworking.com](http://popularwoodworking.com). Send check or money order to: *Popular Woodworking Magazine* Back Issues, F+W Media Products, 700 E. State St., Iola, WI 54990. Please specify publication, month and year.

Copyright ©2010 by F+W Media, Inc. All rights reserved. *Popular Woodworking Magazine* is a registered trademark of F+W Media.





## Introducing a New Kind of Router.

With variable speed 1¼ peak HP, it has the power for tough jobs. And at only 4 pounds, and with a contoured gripping surface and a D-shaped base, the DEWALT compact router is stable and easy to control. The simple adjustment ring and the dual LEDs allow incredible accuracy. And the all-metal motor can means it's built to last. It's another great woodworking tool from DEWALT.



All Metal Motor Can for Durability



Dual LED Lights for Visibility



Easy-to-use Depth Adjustment Ring



1¼ Peak HP with Variable-Speed, Soft-Start Motor



12 Position Spindle Lock

# DEWALT®

visit [dewalt.com/compactrouter](http://dewalt.com/compactrouter)

BY CHRISTOPHER SCHWARZ, EDITOR

# What I Learned at Woodworking in America

I just spent three days teaching hand-tool techniques at our Woodworking in America conference and my staff members are now trying to keep their eyes open long enough to get this issue looking good, reading correctly and in your mailbox.

During my three days at Woodworking in America I talked until my voice was hoarse, answering questions about router planes (which Roy Underhill coined the “One-Tooth Sex Monster” plane), workbenches, saws, chisels and scrapers. But what was most amazing about the conference was how much I learned when I shut my mouth.

I am a confessed moron about Japanese planes, and I’ve been hesitant to set up a Japanese plane that was a gift from a friend. But when I found out that Wilbur Pan, a New Jersey doctor, was attending Woodworking in America, I asked him to give me a lesson in Japanese planes. He agreed.

On my lunch break Saturday we dragged a workbench into a hallway below an enormous window facing the 19th-century streetscape of Covington, Ky. Pan explained the fine points of seating the iron into the wooden body (called the *dai*) and showed me how to adjust the wooden bed to get the iron fitting properly.

While we were talking, other attendees began watching Pan’s mini-lecture. A blogger began filming the event.

Soon everyone was getting into the act. Attendees were giving the planes a try. Pan was explaining how Japanese planing

stops were different and I was thinking of ways to hollow out the sole of my *dai*.

And that’s when tool collector Tony Murland and woodworking legend Frank Klausz walked up and started listening.

I could tell that Pan was a little nervous.

He had started out explaining Japanese planes to just one guy. But now he had a high-powered audience that was growing by the moment. After Pan finished, Klausz added that he had heard that Japanese woods were softer

than American woods – that’s why the tools were different.

Pan took a deep breath, and he politely disagreed with Klausz. I could hear a slight tremor in Pan’s voice as he explained that Japanese furniture was made from a wide variety of woods, including species that were very hard. Klausz listened thoughtfully and nodded his head.

It was an amazing moment for me, seeing this amateur woodworker hold his ground and explain the things he had learned to Klausz. But I knew that this was just one of the hundreds of amazing moments occurring everywhere at Woodworking in America. By the end of the weekend, attendees had also managed to show me a better way to mark hinge mortises and cut rabbets with a chisel.

I just hope that I showed them a few things myself. **PWM**



## Customer Service

How can I contact customer service with questions regarding my subscription, including a lost or damaged issue? Visit [popularwoodworking.com/customerservice](http://popularwoodworking.com/customerservice). Or write to Popular Woodworking Magazine, P.O. Box 420235, Palm Coast, FL 32142-0235. Or, if you prefer the telephone, call 386-246-3369 and a customer service representative will be happy to help you.

## When does my subscription expire?

The date of your subscription expiration appears on your magazine mailing label, above your name. The date indicates the last issue in your subscription.

## Can I get back issues of Popular Woodworking and Woodworking Magazine?

Back issues are available while supplies last. Visit [popularwoodworking.com/backissues](http://popularwoodworking.com/backissues). Or if you know the exact month and year of the issue you want, call our customer service department toll-free at 800-258-0929 to order.

## What if I want more information about the projects and tools I read about in Popular Woodworking Magazine?

For all editorial questions, please write to Popular Woodworking Magazine, 4700 E. Galbraith Road, Cincinnati, OH 45236. Or e-mail [popwood@fwmedia.com](mailto:popwood@fwmedia.com).

## Does Popular Woodworking Magazine offer group discounts?

Group discounts are available by special arrangement with the publisher. For more details, send an e-mail to [Debbie Paoello](mailto:Debbie.Paoello@fwmedia.com) or call 513-531-2690 x11296.

## Our Privacy Promise to You

We make portions of our customer list available to carefully screened companies that offer products and services we believe you may enjoy. If you do not want to receive offers and/or information, please let us know by contacting us at:

List Manager, F+W Media, Inc.  
4700 E. Galbraith Road  
Cincinnati, OH 45236

## Safety Note

Safety is your responsibility. Manufacturers place safety devices on their equipment for a reason. In many photos you see in *Popular Woodworking Magazine*, these have been removed to provide clarity. In some cases we’ll use an awkward body position so you can better see what’s being demonstrated. Don’t copy us. Think about each procedure you’re going to perform beforehand.

## Highly Recommended

When the French rasp maker Auriou went out of business, it was almost a disaster for woodworkers. Luckily, the company has been revived under the name Forge de Saint Juery ([forge-de-saint-juery.com](http://forge-de-saint-juery.com)) with the same craftsmen. The good news is that the new rasps are as amazing as the old.

Yes, the rasps are expensive, but they are worth every penny. We recommend woodworkers get two: a 9" cabinet rasp (10 grain) and a 6" modeller’s rasp (15 grain). You will not be disappointed. In my experience, nothing cuts as smoothly or as cleanly.

— Christopher Schwarz





**BUILD FUN WOOD TOYS**  
Easy to make full size plans and patterns

Trucks, cars, planes, trains, houses, buildings, dragons, dinosaurs, boats, knights, war horses, and much more.

**Toymaker's Library**  
(\$114.70 value)  
**\$99.95** 6 quality hardcover 8-1/2" x 11" books

1-888-962-4714  
Order online today  
**www.toymakerpress.com**  
Buy individual books or as a library set.  
For more information, go to PWFREEINFO.COM.

# Flat. Fast. Built to Last!

Don't waste woodworking time flattening, soaking and cleaning up the mess from conventional sharpening stones! DMT Diamond Whetstones stay precision flat, sharpen faster and will never break. Available in six micronized diamond crystal sizes: 120 micron for rough grind to 3 micron for final polish.

**Dia-Sharp**  
Superior Continuous Diamond

**DMT**  
PROUDLY MADE IN USA

**THE LEADER IN DIAMOND SHARPENING™**  
800.666.4DMT [www.dmtsharp.com](http://www.dmtsharp.com)

See the video! [www.dmtsharp.com/how-to-sharpen](http://www.dmtsharp.com/how-to-sharpen)

For more information, go to PWFREEINFO.COM.

With the right bit you're almost done

Over 1,000 Bits to Choose From

**RouterBits.com**

Order Online or Call our Sales Team Today!

**TylerTool** 1-800-222-8404  
[www.RouterBits.com](http://www.RouterBits.com) is a Division of Tyler Tool Company

For more information, go to PWFREEINFO.COM.

# 10 Stocking Stuffers for the Woodworker

1. Veritas® Miniature Edge Plane 05P81.01 \$34.50 2. Set of 4 Palette Knives 35K09.01 \$9.95 3. Veritas® Set of 3 Imperial Detail Planes (1/4", 5/16", 3/8") 05P75.30 \$175.00 4. Blindman's Fractional Electronic Caliper 88N62.60 \$39.50 5. Carbide Knife Sharpener 70M46.50 \$15.95 6. Mini Edge-Rounding Plane 07P15.07 \$21.50 7. Pair of Ratcheting Screwdrivers 17K01.99 \$19.95 8. Veritas® 4" Sliding Bevel 05N44.02 \$46.50 9. Pair of Trick Bolts 50K26.10 \$19.50 10. Veritas® Miniature Shoulder Plane 05P80.01 \$29.50 Shipping and N.Y. sales tax extra.

**To order these products, call or visit us online.**  
**1-800-683-8170 [www.leevalley.com](http://www.leevalley.com)**  
A Lee Valley gift card is always welcome.

**Lee Valley & Veritas®**

For more information, go to PWFREEINFO.COM.



# Sagging Face Vise Screw Concerns

Looking at how you used the wooden vise screw on the 18th-century bench (from the August 2010 issue, #184), I have a couple questions.

I am about to start cutting the components for my new bench and I have the same screw. How did you attach the nut block to the leg? I assume that you just recessed it in to the rear face of the leg – is that correct? And what are the dimensions of the leg? I have concerns that if I were to do something similar, I would be building in a weak point if the legs were not wide enough.

With the leg vise's parallel guide, have you had any problems with the guide getting skewed vertically in its slot and jamming due to the weight of the vise itself? I was thinking of lining the top and bottom of both the slot and the guide with high-density plastic (or whatever chopping boards are made from) to prevent this sag if it is an issue. I don't want to place undue stress on the screw itself if I can avoid it.

Ray White  
Melbourne, Australia

Ray,  
*The threaded block is attached with friction and glue. It is a very tight fit in the notch in the leg. As a result, the leg (5" x 5") is as stout as it was without the block.*

*I haven't had any problems with the parallel guide jamming in any way. The mortise for the guide (and all the guides I've built) has some vertical play – maybe 1/4". And I've not heard of anyone ever having this problem with a leg vise.*

*As to lining the mortise with plastic, I think wood is slippery enough. But you can always add plastic later if it proves to be a problem.*

Christopher Schwarz, editor

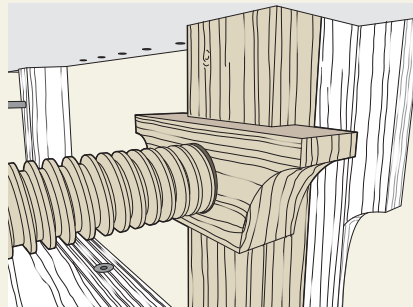

using a jeweler's loupe. Try planing another board of maple from a different tree to see if you have the same results. And, if all else fails, send the blade back for testing by the manufacturer.

Christopher Schwarz, editor

## Moving Beyond 'I Can Do That'

Thank you for the "I Can Do That" manual ([popularwoodworking.com/icandothat](http://popularwoodworking.com/icandothat)). This is simply a fantastic resource (as is your web site in general). As a novice woodworker, I am incredibly grateful for the manual and have found it very helpful in acquiring my first tools. I am thoroughly enjoying working and learning with the ICDT mentality but am wondering if you could give me your opinion about expanding the set of tools.

Because of space limitations, I cannot incorporate a contractor-style table saw and would have to get a nice portable one if I were to add a table saw next. I have also been intrigued by some of the many track saws now available. My main goal is to continue to build furniture purely for my own education, interest and entertainment. I'm not necessarily worried about speed as much as I am about versatility and the ability to continue to learn how to do quality work.

Given that, would you choose to center a shop on a table saw (even if it had to be a portable unit) or would you try to work without it – using something like a track saw for much of that functionality? Or perhaps you have a better suggestion as to where to go after ICDT – keeping a space limitation in mind?

Sean Garrity  
via e-mail

Sean,  
Your question is a good one. But it also is a hard one because there are lots of paths you could take.

A small benchtop saw with proper modern guarding would be an excellent choice if you chose to base your shop around a portable table saw. It's a valid choice – defensible, and one that many woodworkers would make in this country.

## Problems Planing Hard Maple

Could you give me some advice on hand-planing hard maple? I have a few pieces that are approximately 8' long on which I need to joint the edges. However, the wood is so hard that after two passes with my jointer plane, the edge of the blade is rounded over. Would a higher bevel angle on the blade or a thinner cut help? (I currently have a 32° bevel and am taking a cut of about .004".)

James Sherman  
Terre Hill, Pennsylvania

James,  
*The edge shouldn't be dull after so little use in a wood such as maple. There are several things that could be going on:*

- 1. The edge isn't truly sharp or polished enough. Perhaps there are deep scratches you cannot see that are making the edge degrade quickly.*
- 2. The maple has some mineral deposits in it that are dulling your blade.*
- 3. The blade is too soft.*

*I'd investigate each of these in order. Try resharpening and looking for deep scratches*

[www.steebar.com](http://www.steebar.com)

The Only Source You Need For: Clockmaking Supplies, Scroll Saw, Fretwork, Woodworking Plans & Patterns, Yard Decorations, & More!!!



Clock Kits



Clock Inserts



Clock Motors

[www.penmakingsupplies.com](http://www.penmakingsupplies.com)

For All Penmaking & Turning Supplies



[www.woodworkingcrafts.com](http://www.woodworkingcrafts.com)

The webs most definitive woodworking forum!  
Buy/Sell Online • News • Photo Gallery • Chat Room

WWW.STEEBAR.COM, P.O. Box 607, Peapack NJ, 07977  
Ph: (908) 204-0095 Fax: (908) 204-0099

For more information, go to [PWFREEINFO.COM](http://PWFREEINFO.COM).

**Woodpeckers®**  
PRECISION WOODWORKING TOOLS

## Side Winder Router Lift.

**New**

The new Woodpeckers® Side Winder Router Lift makes using your router table even easier.



Quick Lift  
from the top.  
Micro adjust  
from the side.

Made in U.S.A.

[www.woodpeck.com](http://www.woodpeck.com)

1-800-752-0725

See your local dealer for availability.

Protected by one or more of the following U.S. Patents; 6,505,659; 7,559,347; 7,481,253; 7,108,463 and other patents pending.

For more information, go to [PWFREEINFO.COM](http://PWFREEINFO.COM).

## IT'S A HELICAL GOOD PLANER



FOR WOODWORKERS | BY WOODWORKERS

INTRODUCING THE WORLD'S FIRST PORTABLE PLANER WITH ACCU-HEAD CUTTERHEAD — WITH AN AMAZING PRICE UNDER \$600.



Steel City's 13" Deluxe Portable Planer 40200H features patented helical cutterhead with 2-sided HSS knife tips sharpened to perfect wood cutting angle which is not achievable in Tungsten Carbide application.



Tip View 1

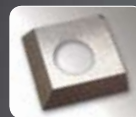

Tip View 2



**SPECIAL OFFER AT \$5XX.00** available with limited quantity. To reveal the actual price, please check with Steel City dealers.

For more details about our products and complete dealer listings, please visit: [SteelCityToolWorks.com](http://SteelCityToolWorks.com)

For more information, go to [PWFREEINFO.COM](http://PWFREEINFO.COM).



CONTINUED FROM PAGE 12

Using a track saw (also called a plunge-cut saw) or circular saw is another option. They are great for rips and sheet goods, but not for building furniture.

If I were in your position, I would go one of two routes:

1. Buy a 14" band saw, which would have the same footprint as a portable table saw. A band saw can do almost anything – curves, tapers, straight work, pattern work, joinery, you name it. A used band saw is always an excellent buy.

2. Consider incorporating more handwork into your shop. You can break down stock using your circular saw and jigsaw, then do the joinery with a few backsaws and planes.

Both are sensible approaches. It just depends on what appeals to you.

Christopher Schwarz, editor

### Disston Information Please?

I bought an antique saw box full of old saws. I was poking through them and one of them is a Disston D23. Is there a web site where I could research what I have?

Stephen Ayotte  
via e-mail

Stephen,

Try the [disstonianinstitute.com](http://disstonianinstitute.com). That's the best starting point for all things Disston.

Christopher Schwarz, editor

*"Man is so made that he can only find relaxation from one kind of labor by taking up another."*

— Anatole France (1844-1924)  
French poet, journalist and novelist

### 'Design by Eye' Clarification

Jim Tolpin's "Design by Eye" (October 2010, issue #185) was inspiring. However, I am not clear as to how the step board fixes to the leg assembly. Jim writes, "with a pair of sliding dovetails reinforced against side movement with pocket screws," but this is brilliantly invisible in the photographs. I say "brilliantly" because something as elegant as this should not, in my opinion, give all its secrets away at first

glance. However, I cannot work out how the sliding dovetails fit with the canted-in legs – I may be missing something obvious. But if so, forgive this amateur. Either way, could you be persuaded to show the "workings" under the step board?

Eric Gower  
Southhampton, England

Bevel on underside helps disguise dovetail slot

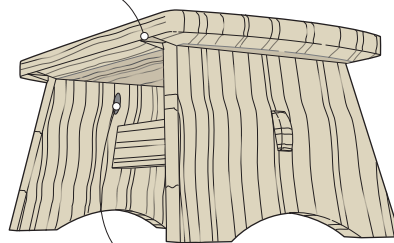

Pocket screw close to, but not on, centerline

Eric,

Here's an illustration that shows how the legs of the stool are attached to the top in sliding dovetails. Notice how the taper along the edge of the stool works to hide the dado from showing.

The screws (or tiny cut nails) go through the leg near the center point and into the underside of the top. This keeps the leg from shifting along the length of the dovetail/dado. Any shrinkage or expansion of the leg takes place on either side of the fastening, so there is no concern about splitting.

Jim Tolpin, contributor

### What's First in Story Selection – Technique or Aesthetics?

First of all, this is not a "sour note" letter. In fact, I consider your magazine to be one of the best.

To introduce myself, I am a retired engineer, an old geezer (I'm 89) and an avid dilettante woodworker.

The question I have is this:

When you (your magazine) look at a project, do you look at it primarily as a way to teach techniques? And at what point do you consider the aesthetics?

For example, in the October 2010 issue (#185) the article by Toshio Odate was outstanding and you can feel the beauty of the work. On the other hand, the Arts & Crafts buffet is a monstrosity in my opin-

ion. The three-legged chair is beautiful; the factory cart coffee table is something I would have built as a youth when I had only a saw and hammer.

However, your 18th-century workbench (August 2010 issue, #184) is a thing of beauty, is constructed with well-engineered technique and is worthy of the material used. And I would not be ashamed to put it in my living room.

James Carp  
San Luis Obispo, California

James,

Thanks for your thoughtful letter.

The short answer is that we consider the techniques and the aesthetics. However, the aesthetic choices are never from one person's point of view (even though I am the editor).

Matters of taste in woodworking are tough. We have a staff of experienced woodworkers who all have different tastes, which range from the 17th century to the 21st. When putting together an issue, I try to balance the different styles and different techniques, and I try to remain open to methods and projects that are not to my liking, but are valid.

Sometimes we succeed. Sometimes we don't.

I appreciate you letting me know what appeals to you and what doesn't. That is always a help. And we always appreciate honest and constructive feedback such as yours. PWW

Christopher Schwarz, editor

### Go Online FOR MORE ...

#### Letters and Comments

At [popularwoodworking.com/letters](http://popularwoodworking.com/letters) you'll find reader questions and comments, as well as our editors' responses.

#### We want to hear from you.

Popular Woodworking Magazine welcomes comments from readers. Published correspondence may be edited for length or style. All correspondence becomes the property of Popular Woodworking Magazine.

Send your questions and comments via e-mail to [popwood@fwmedia.com](mailto:popwood@fwmedia.com), or by mail to:

Letters, Popular Woodworking Magazine  
4700 E. Galbraith Road  
Cincinnati, OH 45236



Item #P410

Premier

FUSION

# HOW CAN THE BEST GENERAL PURPOSE SAW BLADE GET EVEN BETTER?

## Make It Available In Thin & Full Kerf Designs For Every Table & Chop Miter Saw!

Introducing the Premier Fusion saw blade in both Thin and Full Kerf design. Now woodworkers have a superior general purpose blade for both the table and chop miter saw in the shop and for the lower horsepower saw on the job site. The New Thin Kerf combines the advanced Premier Fusion features with a thinner kerf design to provide a flawless finish while reducing material waste, which makes it the ideal choice for lowered powered saws.

Freud's patent-pending Premier Fusion Saw Blade is the most technologically advanced blade on the market with a radical new "Fusion" tooth design that combines a double side grind with a 30 degree Hi-ATB to produce a glass-smooth, chip-free top and bottom surface while ripping and crosscutting.

The unique Fusion tooth design, combined with Freud-made TiCo™ Hi-Density Carbide, superior anti-vibration design and patented Perma-SHIELD® non-stick coating create the ultimate general purpose saw blade with flawless cutting performance.

Choose from four blades in the Full Kerf Premier Fusion series – 8", 10", 12" and 14" or try the new Thin Kerf 10" Premier Fusion. Use a Premier Fusion blade once and you'll be convinced.

**NEW**

Item #P410T

### Freud's Fusion Tooth Design vs. Others



To sign up for Freud's e-mail newsletter or to find a dealer near you visit or call:

[www.freudtools.com](http://www.freudtools.com)  
1-800-472-7307

# freud®

Precisely the best.

EDITED BY KARI HULTMAN

THE WINNER:

# Auxiliary Band Saw Table

When I rough out work on the band saw, I often find little pieces getting stuck in the throat insert or the split in the table. Also, I find that work can catch in the miter slot. So, I made an auxiliary table to solve these problems.

I used a sheet of 1/4" particleboard that is coated on one side with melamine (the minimal thickness reduces the amount of lost resaw capacity), but you

can use 1/2" or thicker material, such as Baltic birch plywood. Size your table according to your needs.

I rounded all the corners and epoxied a strip of hardwood, matching the width and length of the miter slot, to the underside of the particleboard.

To keep the auxiliary table from moving during use, I used a Forstner bit to inset a couple rare earth magnets in the hardwood strip.

Be sure to remove the table when not in use, especially if you're cutting wet wood. Clean and wax the cast iron table to prevent rust from developing.

Will Simpson  
Moscow, Idaho

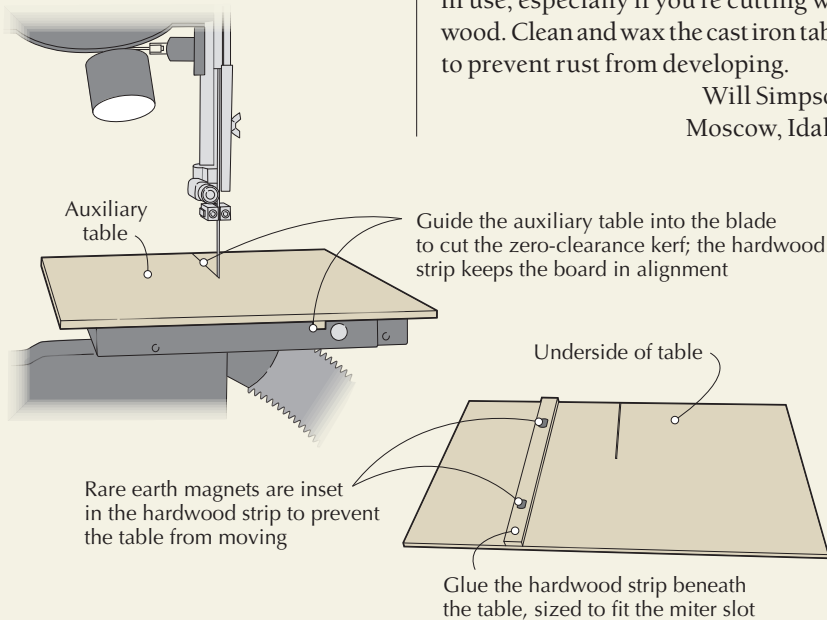

## Bench Jig for Thin Pieces

Most of the time, the end vise on my workbench is more than adequate to secure workpieces between bench dogs. Occasionally, though, I need to work with thin wood at the front edge of the bench (such as when using a plow plane to groove small box sides). For this, I need a holding device that won't be in the way of the plane or its fence.

I have found that wood dowels (matching the diameter of your dog holes) that are inserted into through-holes in small pieces of scrap wood (that are thinner than your workpiece) are a useful accessory. Dowels equipped with a brass ball catch can be tapped flush with the surface of the scrap wood.

By placing one jig in the two end-vise holes and one jig in two bench holes, I can hold small pieces securely and be assured that the plow plane has clearance. Neither jig should overhang the front of the bench. That way, the plane's fence registers off the workpiece's edge, not your workbench.

If you have only one hole in your end vise, glue a strip of wood to the front edge of the scrap wood and use just one dowel. The wood strip prevents the jig from shifting.

Jim Quinlivan  
Torrance, California

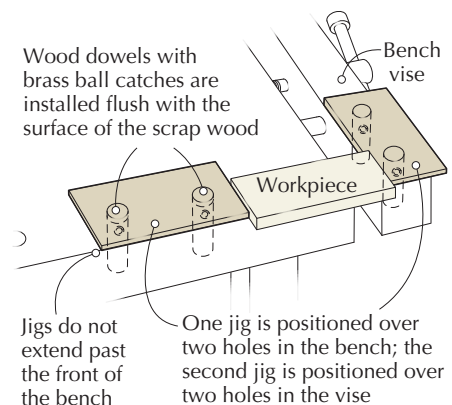

If you have only one hole in your vise, glue a strip of wood to the front edge of the jig and use just one dowel; the wood strip prevents the jig from shifting

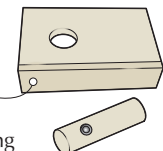

## Zero-clearance Insert for the Miter Saw

People often use a zero-clearance table saw insert to prevent tear-out, so I decided to make one for my miter saw.

I spread apart the plastic insert halves that came with my saw and cut a strip of hardwood to fit snugly in the slot. Then, I lowered the blade to cut a groove in the piece of wood. I make separate inserts for left- and right-angle cuts, and make new inserts when they show wear.

The wooden inserts work much better than the plastic one. There's less chance of a thin offcut falling through the slot and getting caught in the blade, and it's better support for very thin workpieces. Also, the zero clearance helps prevent tear-out and the kerf helps me register cutlines.

Dan Miller  
Elgin, Illinois



**WHITECHAPEL LTD**  
*Over 4000 fine hardware essentials*



English Art Nouveau Handle

315 PAGE COLOR CATALOG \$5.00  
 1-307-739-9478 whitechapel-ltd.com

For more information, go to [PWFREEINFO.COM](http://PWFREEINFO.COM).

**WWW.RADARCARVE.NET**  
**Wood Carving Duplicators**

- Furniture
- Gunstocks
- Millwork
- Decoys
- Musical Instruments

*Incredibly accurate*



Thousands of Uses 505-948-0571

For more information, go to [PWFREEINFO.COM](http://PWFREEINFO.COM).

**EAGLE**  
 AMERICA  
 The World's Router Bit & Woodworking Source!

OVER 2,000 Router Bits!  
 OVER 6,000 Woodworking Items!



**FREE Shipping**  
 On your order of \$75. Use offer code PW1012.  
 Prior orders excluded. Ends 2/28/2011.

1-800-872-2511  
[www.EagleAmerica.com/PW1012](http://www.EagleAmerica.com/PW1012)

For more information, go to [PWFREEINFO.COM](http://PWFREEINFO.COM).

**EIP** INC

With over 30 years of experience in producing lumber dryers you can count on EIP's dependability and simplicity.





We offer four models ranging from 800 BF to 10,000 BF

**Ebac Industrial Products Inc**  
 700 Thimble Shoals Blvd, Suite 109, Newport News, VA 23606-2575  
 Tel 757 873 6800 Fax 757 873 3632  
 Toll Free 1-800-433-9011 [www.ebacusa.com](http://www.ebacusa.com)

For more information, go to [PWFREEINFO.COM](http://PWFREEINFO.COM).

# Finishing Made Easy!





Apollo HVLP Power Series



Techniques



Waterbased Coatings & Wood Stains



Aqua Coat & Aqua Tone Stains



Preparation Products



Painter's Pyramid



3M Paint Preparation System



Expert Tips



Soy Gel

**The Go-To Site for Finishers**

**The Finishing Store.com**

Call or Click today 1-888-900-4857 or [www.thefinishingstore.com](http://www.thefinishingstore.com)

For more information, go to [PWFREEINFO.COM](http://PWFREEINFO.COM).

CONTINUED FROM PAGE 16

### Clamping Method for Small Mitered Frames

Although I have several commercially made accessories for clamping mitered frames, they don't work well on small frames. So, I devised my own small-frame clamping method.

First, I made four V-shaped corner blocks out of  $\frac{3}{4}$ " MDF. Along the outside edge of each corner piece, I cut a groove about  $\frac{1}{4}$ " deep and  $\frac{1}{4}$ " wide, and drilled a hole in each inside corner to allow for glue squeeze-out.

Then, I screwed one of the corner blocks to a sheet of plywood; this stationary block helps stabilize the clamping process. I laid a sheet of waxed paper on the plywood to prevent the frame from sticking to it.

After applying glue to the mitered frame corners, I slid the frame between

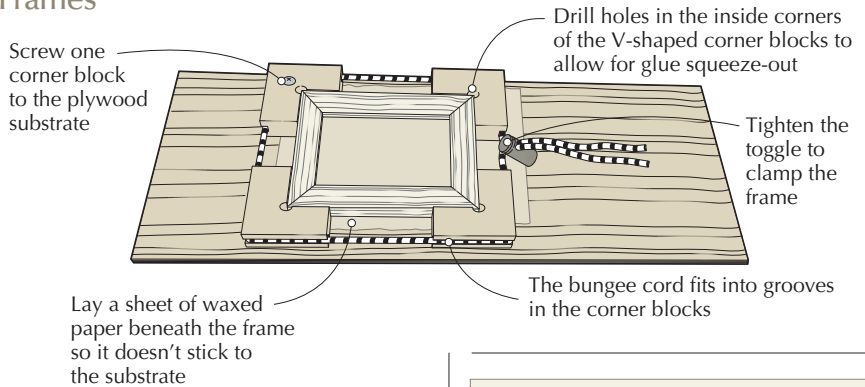

the four corner blocks. Then, I stretched a length of bungee cord around the corner pieces and secured it with a toggle. The grooves hold the cord in place.

Bill Wells  
Olympia, Washington

### Go Online FOR MORE ...

You'll find links to all these online extras at:  
► [popularwoodworking.com/dec10](http://popularwoodworking.com/dec10)

**VIDEO:** *Tricks-in-Action* shows you a free video of one of this issue's tricks in use in our shop. Watch "Bench Jig for Thin Pieces"—as well as a few of our other favorites.

**WEB SITE:** Visit the new *Tricks of the Trade* page online.

**BLOG:** *Tricks* editor Kari Hultman writes about woodworking on her blog, *The Village Carpenter*.

**IN OUR STORE:** Get "601 Woodshop Tips & Tricks," by Graham McCulloch.

All of our products are available online at:  
► [WoodworkersBookShop.com](http://WoodworkersBookShop.com)

### Cash and prizes for your tricks and tips!

Each issue we publish useful woodworking tips from our readers. Next issue's winner receives a \$250 gift certificate from Lee Valley Tools, good for any item in the catalog or on the web site ([leevalley.com](http://leevalley.com)). (The tools pictured below are for illustration only, and are not part of the prize.)

Runners-up each receive a check for \$50 to \$100. When submitting a trick, include your mailing address and phone number. If your trick is selected, an editor will need to contact you. All entries become the property of *Popular Woodworking Magazine*. Send your trick by e-mail to [popwoodtricks@fwmedia.com](mailto:popwoodtricks@fwmedia.com), or mail it to Tricks of the Trade, *Popular Woodworking Magazine*, 4700 E. Galbraith Road, Cincinnati, OH 45236.

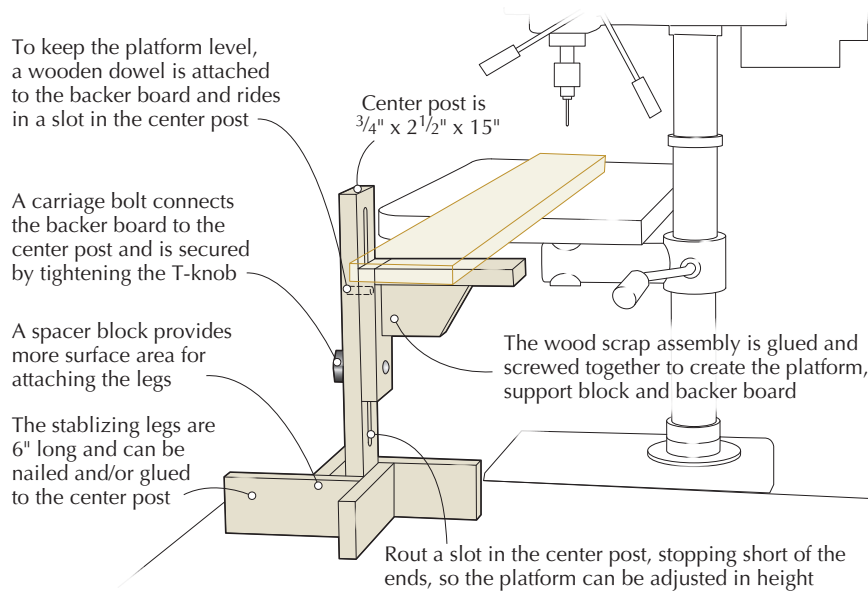

### Drill Press Extension Table

My basement shop is quite small and my drill press is right next to my workbench. When I needed to drill a long board, I would stack pieces of wood on top of my workbench to act as a support.

I decided to build a holder to sit on my workbench that would allow me to vary its height more accurately and easily than a stack of wood. It is 15" tall and adjustable from 7" to 14". The stabilizing legs ensure that it won't tip over.

I routed a slot in the center post, attached a small table with a support block to a plywood backer board, and drilled a hole for a carriage bolt that goes through the plywood backer board and the slot. A T-knob tightens the bolt at the right height. Protruding from the plywood through the slot is a short dowel that helps keep the table level. **PWM**

Dward Moore  
Brunswick, Maryland



# Meet a new company with a 64 year heritage.



We're new to the neighborhood. But not the industry. For more than 60 years, Canadian-based General Mfg. has been designing, producing and selling high quality, reliable woodworking machinery. Now we've opened our first American distribution center in Murfreesboro, TN. This new venture will allow us to better serve our American distributors and their customers. So you'll enjoy faster, easier access to our extensive line of woodworking products. And know that whatever you build, your tools were built on a long, proud heritage of trust. For more information visit [general.ca](http://general.ca).



[www.general.ca](http://www.general.ca)

General® International USA Inc., 760 Jessica St., Murfreesboro, TN 37130

For more information, go to [PWFREEINFO.COM](http://PWFREEINFO.COM).



BY THE EDITORS

# Bickford Moulding Planes

From high finance to high-quality planes.

Vintage moulding planes are tricky beasts. Typically the wood is warped, the irons are misshaped and the wedges are beat to snot. So it's no wonder that people struggle with the tools.

This year Matt Bickford became a full-time planemaker to help supply woodworkers with moulding planes that work like they should. Bickford is a long-time woodworker and a former derivatives trader who gave up the world of high finance to build planes in his basement shop, mostly by hand and with incredible attention to detail.

This year I purchased some of his tools and have been building furniture with them. I am impressed.

His tools look similar to the British moulding planes made by Clark & Williams of Eureka Spring, Ark. That should come as no surprise because Bickford learned to make the tools from the company's excellent DVD on the topic.

## M.S. Bickford Moulding Planes

M.S. Bickford ■ [msbickford.com](http://msbickford.com)  
or 860-467-6937

Street price ■ \$300 a pair

► Read more about Bickford on our blog at [popularwoodworking.com/dec10](http://popularwoodworking.com/dec10).

Price correct at time of publication.



**Making mouldings.** Short runs of mouldings are easy to make with these planes. And here's a bonus: No more sanding mouldings.

But there are some differences. Bickford offers his tools in both beech and cherry. Beech is the traditional wood, but I tried out the cherry ones. I found cherry to be entirely suitable for this form of tool. Bickford also offers his simple rabbit plane with one corner boxed in persimmon. This hard corner offers you a great way to start a moulding using only a simple gauge line. Very nice.

The irons in Bickford's planes come from Lie-Nielsen Toolworks, so you know the steel is excellent.

As far as fit and finish go, I would say that Bickford's are excellent. He's not quite up to the level of Clark & Williams (which is a totally insane level of perfection), but they are better than much of the vintage tools out there. And the young Bickford has many years of planemaking ahead of him.

From a user's perspective, the tools are a dream. They come sharp (really sharp) and ready to put to work. The throats are tight to reduce tear-out. The wedges fit nicely and hold the irons tight to the 55° bed.



**Look close.** The details on Bickford's planes are crisp and executed mostly by hand. Nice.

But most of all, these planes give you the freedom to make any moulding you can conceive of. You don't need hundreds of router bits or crazy jigs—just a few moulding planes, a rabbit plane and a nice cutting gauge.

If you are looking to get started in moulding planes, you also should check out Bickford's "starter set" of moulding planes, which actually will probably be enough for most woodworkers for a lifetime.

— Christopher Schwarz

CONTINUED ON PAGE 22

PHOTO SBY AL PARRISH



## Wood Gear Clock Kit



**Now in Mission Style too!**



Create this working work of art with Woodline's Wooden Gear Clock Kit. The kit includes full size gear templates, hardware kit, spiral bit, and full instructions on CD and DVD. The provided wood kit includes 6 pieces of specialty plywood for gears in your choice of walnut or cherry. You supply the other wood needed from your scrap box. Grandfather style design with pendulum & weights.

WL-WCK-DPC Cherry Kit  
WL-WCK-DPW Walnut Kit

**ONLY \$249**



Woodline Pin Router  
Accessory included

## DadoMax™

Make precise no-rattle dados with a router instead of a cumbersome dado blade with the new improved DadoMax™. Complete details and instructions are available for you at our website, [www.woodline.com](http://www.woodline.com).

**ONLY \$99**

WL-DMAX Reg. \$109

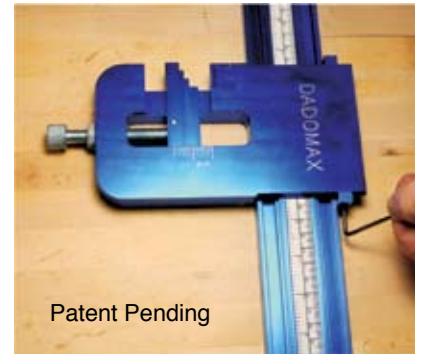

Patent Pending

## 30pc Professional Set

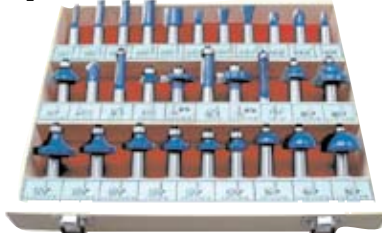

5 Straight, 6 Roundover,  
3 Dovetail, 3 Core Box,  
3 Cove, 2 Flush Trim, 1 Panel Bit,  
2 Roman Ogee, 2 Slot Cutters,  
1 V Groove, 1 Chamfer, 1 Bevel Trim

WL-2010

**\$109**

## TriStar 6pc Cabinet Set

3 Wings for smooth cuts



3 1/4" Ogee Panel Raiser  
2 pc Ogee Rail & Stile  
Reversible Glue Joint  
Drawer Lock Door Lip

WL-2020-3

**\$169**

## Molding Sets

FREE MOLDING BOOK ON CD WITH EITHER SET. Shows you how to layer bits for unique profiles.



### 5Pc Molding Set WL-2011



### 8Pc Classical Set WL-2016

1/2" Shank only



**Either Set \$99**



## Arch Panel System



WL-ARCHC Cathedral



WL-ARCHR Roman

The Panel Master System makes routing raised panels safe and easy. A Blue Max 360 clamp holds the templates in place with handles giving precise control. Choice of Cathedral or Roman templates.

**\$109**

## Inlay Kit

Includes bushing & 1/8" solid carbide down spiral. Fits 1 3/16" standard size hole.

WL-INLAY

**\$20**



## 5pc Cabinet Shaper Set

Ogee Profile

WL-1505 3/4" Bore

**\$199**



- Fine Quality Carbide Bits
- Affordable Custom Bits
- Wooden Hand Planes
- Complete Selection of Individual Bits and Shaper Cutters
- Turning Tools & Accessories
- Visit [www.woodline.com](http://www.woodline.com) for our full line
- Unsurpassed Customer Service

CONTINUED FROM PAGE 20

## Value in Chisels made in the U.S.A.

Six months ago, I went looking for a new set of chisels. I wanted wood handles and I also wanted tools that didn't taper too much at the sides. That's a popular feature these days, but except when paring narrow spaces between dovetails, it can do more harm than good.

I was intrigued when I found this set of American-made chisels from Buck Brothers. They looked good, but the price seemed too good to be true. When they arrived, they didn't need much preparation to go to work, and I was pleasantly surprised.

### Buck Bros. Bench Chisels

Buck Brothers ■ 508-865-4482

Street price ■ \$58.50 set of six

► Ron Hock explains how to sharpen chisels at [popularwoodworking.com/dec10](http://popularwoodworking.com/dec10).

Price correct at time of publication.

For simple tools, chisels are exceptionally versatile. Tasks range from paring off a thin shaving to chopping out the waste of a mortise or dovetail socket. In an age of specialization, these chisels from Buck Brothers are a good value and capable as all-around utility players.

The fit and finish are acceptable, considering the price. Grinding marks are visible on the edges and top of the blades, and the leather caps were a bit rough where they met the wood handles. On the other hand, the backs flattened easily, and the cutting edge was properly ground. They may not be gorgeous, but they do the job.

Once honed, the edges held up nicely in use. The handles are large and I found them comfortable for paring, and substantial enough for chopping. The sides don't



taper to a narrow edge – there is some thickness, making these a hybrid between a paring chisel and a mortise chisel.

After several months, I'm still happy with them. They aren't the prettiest tools in the rack, but they have held up to a variety of tasks, and they didn't break the bank. As a starter set (or an extra set) I recommend them highly.

— Robert W. Lang

## A Better Brad-point Bit

When I grab a brad-point bit to drill a hole, I don't give much thought to the design of the bit and to the finer intricacies of just how holes are drilled. But the German company that produces the Colt line of drill bits does just that. That's why Colt products, such as the Five Star Wood Drills, rank at the top.

There are two prominent features that make these bits stand out. First is the point of the bits. Five Star bits have a longer point than those found on conventional brad-point bits, and that point has its own

precision-ground cutting edges to allow it to cut as it enters the wood. Other brad-point bit points have no cutting edge so they have to be pushed through the cut. And the longer point translates into less of a chance of skidding across the workpiece when beginning a hole at an angle. As a result, Five Star bits complete the cut with little noticeable blowout, which makes them the perfect choice for all woods, laminates and even plastics.

A second feature that makes Five Star bits a better choice is a patented "twin-land" flute design. This design has two ground surfaces that rotate against the walls of the hole to keep small pieces of waste in the flutes and lifted out of the hole without excessive heat buildup. Excessive heat causes bits to dull faster.

Also, Colt manufactures the Five Star bits with a flute angle of 25° versus the 30°-40° angle in conventional drill bits. This also allows waste to exit the hole



more quickly and with less friction, so as not to dull the bits' sharp edges.

These bits are available individually, or you can purchase an assembled seven bits (1/8" through 1/2", in 1/16" increments) in a wood box. **PWM**

— Glen D. Huey

### Colt Five Star Wood Drills

Horst Miebach GmbH ■ [colt-tools.de](http://colt-tools.de)  
or +49 2266 1266

Street price ■ \$70

► For a look at the Colt MaxiCut Forstner bits go to [popularwoodworking.com/dec10](http://popularwoodworking.com/dec10).

Price correct at time of publication.





Add versatility to your projects with our new Table Slides.



YOUR <sup>NEW</sup> SOURCE FOR TABLE SLIDES

TABLE SLIDES

EQUALIZER SLIDES

866.963.5576

www.osbornecarving.com

For more information, go to PWFREEINFO.COM.

**EXCLUSIVE!**

# INFINITY

CUTTING TOOLS

## Carbide & HSS Knives

### DEWALT DW735 PLANER



- ✓ Thicker
- ✓ Stronger
- ✓ Lasts Longer

**From \$79.90**

infinitytools.com | 877-USA-BITS

For more information, go to PWFREEINFO.COM.



If you are in a woodworking business... this could be the most valuable tool in your office™.

Please call 1-800-321-9841 for your 800 page catalog.

Mention code pw10

**FREE** to woodworking businesses.

visit us at [pro.woodworker.com/pw10](http://pro.woodworker.com/pw10)

For more information, go to PWFREEINFO.COM.

## STEVE WALL LUMBER CO.

Quality Hardwoods and Woodworking machinery For The Craftsman and Educational Institutions

Ash	4/4	Select	\$2.60	UPS	\$94.00
Basswood	4/4	Select	\$1.95	Specials	\$80.00
Birch	4/4	Select	\$3.55		\$108.00
Butternut	4/4	1C	\$2.95		\$88.00
Cherry	4/4	Select	\$4.90		\$117.00
Hickory - Pecan	4/4	Select	\$3.00		\$100.00
Mahogany (Genuine)	4/4	Select	\$4.70		\$112.00
Maple (Hard)	4/4	Select	\$3.45		\$108.00
Maple (Soft)	4/4	Select	\$2.50		\$88.00
Poplar	4/4	Select	\$1.80		\$78.00
Red Oak	4/4	Select	\$2.70		\$96.00
Walnut	4/4	Select	\$4.90		\$115.00
White Oak	4/4	Select	\$2.70		\$96.00
Cedar (Aromatic Red)	4/4	1C+Btr.	\$1.80		\$78.00
Cypress	4/4	Select	\$2.60		\$90.00
White Pine	4/4	F.G.	\$1.25		\$70.00
Yellow Pine	4/4	Clear	\$2.30		\$82.00

SEE OUR CATALOG ON THE WEB!

Above prices are for 100 quantities of kilndried rough lumber sold by the Bd. Ft. FOB Mayodan, NC. Call for quantity discounts. Other sizes and grades available.

Above prices are 20 bd. ft. bundles of clear kilndriedlumber 3"-10" wide • 3'-5' long (Random widths & lengths) Surfaced 2 sides or rough. Delivered UPS prepaid in the Continental U.S.

**OLIVER MACHINERY DEALER**

**HARDWOOD PLYWOOD**

**CUSTOM RAISED PANEL DOORS**

**CUSTOM PLANK HRDWD FLOORING**

**THIN CRAFTWOOD**

**EXOTIC LUMBER**

**STEVE H. WALL LUMBER CO.**  
 BOX 287  
 MAYODAN, N.C. 27027  
 336-427-0637  
 1-800-633-4062  
 FAX 336-427-7588  
 Email: [wood@walllumber.com](mailto:wood@walllumber.com)  
 Website: [www.walllumber.com](http://www.walllumber.com)

Send \$1.00 For Lumber Catalog  
 Prices Subject to Change Without Notice

For more information, go to PWFREEINFO.COM.



**Rikon 16" Scroll Saw**  
with DVD & 72 extra blades  
regular \$205.88 **\$149.99**



**European Workbench**  
regular \$499.99 **SALE \$399.99**



**Steel City 13" Helical Planer**  
regular \$599.99 **\$499.99**

**HIGHLAND Woodworking** 800-241-6748 (While supplies last. Shipping charges extra)  
[highlandwoodworking.com](http://highlandwoodworking.com)

For more information, go to PWFREEINFO.COM.

# BUILD IT TOUGH.



High strength with a shorter clamp time along with no dyes for a natural finish makes Gorilla Wood Glue ideal for your woodworking and building projects.

FOR THE TOUGHEST JOBS ON PLANET EARTH®

**GORILLA TOUGH** .COM

1-800-966-3458 Made in U.S.A.   
 © 2010 Gorilla Glue Company

For more information, go to PWFREEINFO.COM.

# BRING ARTS & CRAFTS STYLE HOME



## BUILD 14 PROJECTS USING DIMENSIONAL LUMBER

Build attractive furniture for anywhere in your home, using dimensional lumber available at local home center stores. Use 1×4s, 2×4s, and plywood and simple joinery like biscuits, dowels, and screws to build inspired Arts and Crafts furniture and household pieces.

Don't settle for clunky furniture projects!

Get *Arts & Crafts Furniture Anyone Can Make* and other quality products at Woodworker's Book Shop — [www.woodworkersbookshop.com](http://www.woodworkersbookshop.com).



Z7617 | 987-1440306730 | 160 pages  
Paperback | \$24.99



# 26 practical and simple furniture projects

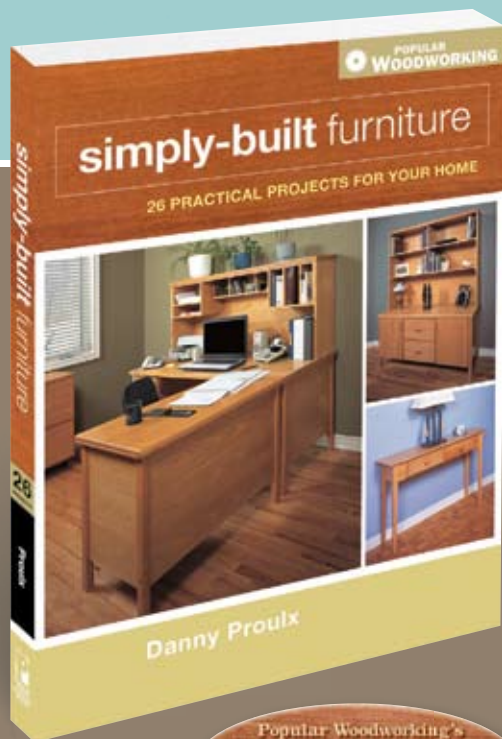

## DANNY PROULX'S BEST PROJECTS FOR THE HOME

*Simply-Built Furniture* offers 26 step-by-step illustrated home furniture projects from the collection of renowned woodworker Danny Proulx. Build pieces such as a rustic pine chest of drawers, a bed with built-in storage, a window seat, a tall bookcase and more.

Whether you're a beginner or an experienced woodworker, you'll appreciate Proulx's no-nonsense approach to woodworking and easy style of teaching.

Get *Simply Built Furniture* and other quality products at Woodworker's Book Shop — [www.woodworkersbookshop.com](http://www.woodworkersbookshop.com).

Z7617 | 987-1440310362 | 244 pages  
Paperback | \$19.99

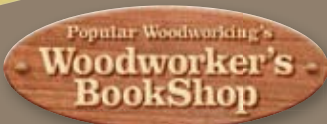



# Popular Woodworking's Woodworker's BookShop

## WHAT'S NEW in the BOOKSHOP



### 'Puzzle Box Magic' DVD

Jeff Vollmer, the "King of Puzzle Boxes," unlocks the secrets to making these fun and fanciful band-sawn projects with more than two hours of video instruction – everything from setting up and tuning your band saw for maximum performance to selecting the best wood, to making multiple complex cuts and choosing the best finish.



### Popular Woodworking Magazine 2010 Annual CD

All seven issues from 2010 on one easy-to-search, easy-to-use disc. It's more than 400 pages of pure woodworking information, with 25+ furniture and shop projects, 10 expert finishing articles, techniques for hand and power tools, tool reviews, no-nonsense jigs and more!

## Editor's TOP PICK

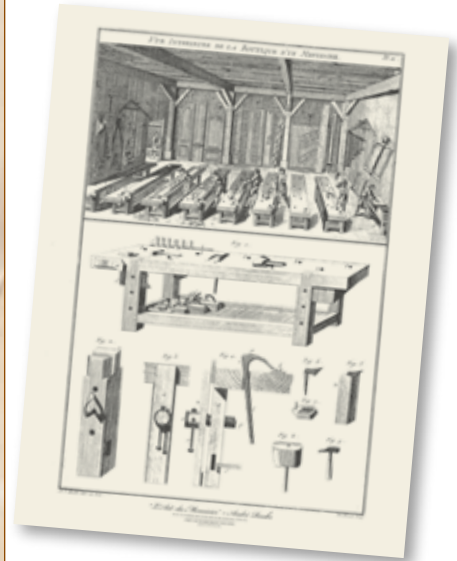

### André Roubo's Plate 11

This poster is the drawing that launched 1,000 workbenches. When I first saw this plate in André Roubo's 18th-century masterwork, "L'art du Menuisier," I immediately began building a French-style workbench like the one shown in this poster. But Plate 11 is more than just a drawing of a bench. It shows a working shop filled with the bustle and handiwork of an 18th-century shop. The detail is extraordinary – be sure to check out the jigs on the walls. I've spent hours poring over this plate, and now you can, too. We're offering Plate 11 as an 18" x 24" poster printed in the U.S.A. on heavy cream-colored paper for \$19.99. It's the perfect thing to hang in your shop or in your office. (And I bet you know someone who could make you a custom frame for it.)



### Go to Woodworking School Without Leaving Home

Get top-notch video instruction on a wide variety of woodworking topics with our ShopClass videos (available as digital downloads and on disc).

- Learn SketchUp, an invaluable 3-D modeling program, with "SketchUp for Woodworkers."
- Get an excellent finish every time with "The 10 Commandments of Finishing."
- And more!



### Get the Most Out of Woodworking!

Join the Woodworker's BookShop VIP program today! Your one-year paid membership includes:

- A one-year/7-issue subscription to *Popular Woodworking Magazine*.
- *Popular Woodworking's* 2004-2008 Compilation CD, with 35 issues on one CD.
- Member-only savings that let you save more on every order from the Woodworker's BookShop.

*Why Shop at the  
Woodworker's  
BookShop?*

- ▶ Savings Up To 60% Off Retail Price
- ▶ The Best Project Downloads
- ▶ Books, DVDs, CDs
- ▶ Printed Project Plans
- ▶ Shop Class – Online Classes
- ▶ FREE USPS Shipping in the Shop when you spend \$25! Just enter offer code PW10 at checkout! (Some exclusions apply.)

These products and more at [WoodworkersBookShop.com](http://WoodworkersBookShop.com)

BY GEORGE R. WALKER

# Great Legs

Play with proportion to achieve pleasing design.

The black stallion's name was Step. Marvin, the only man I ever saw ride him, called him simply "the horse," his raspy Southern voice pausing for emphasis. I was 5 years old the first time I laid eyes on Step. He was the scariest and most wonderful thing I'd ever seen. A force of nature, his frame all rough and muscled as though a master sculptor had chiseled him out in a hurry. His ebony coat reflected blue and purple in the sunlight, and the turf shook when he stomped his hoof. Perhaps the thing about Step that set him apart was that everything about him was perfectly proportioned. His massive iron-like legs would have been out of place on a lesser horse, but they fit perfectly with his body and muscular neck.

There's a lesson there. When proportioning legs to a furniture design the legs need to reflect and connect with the overall mass they support. A workbench uses sturdy tree-trunk-like legs not just for structural support, but also because the hefty timbers visually support the massive top.

I've been looking at legs on furniture and studying how they are proportioned. Because they play a key role in such a wide variety of forms, there are few rules that apply across the board. A light side table calls for a much thinner leg than a dining table, even though they are similar in height. Sounds easy, but it can be challenging to design a leg that's sturdy enough and still looks like it belongs with the overall mass of the piece. I tend to make legs too stocky and have learned through my mistakes to scale them back. Make it a point to



**A perfect fit.** The tapered legs on this table by Gerald Curry flow nicely with the overall form.

closely examine how the legs are proportioned in a variety of built work. Regardless of style, this can help you develop a good eye for proportions.

## Add Some Taper

You can also design legs that complement by including some sort of taper, often with the leg heaviest where it's joined to the table apron, case or chair seat. This is a traditional approach that mimics many of the forms we see in nature. Think about how your arms and legs are proportioned. Our limbs are thicker near our torso and taper down to our wrists and ankles. Straight legs work great for a workbench and supply a built-in square reference surface, but to my eye a straight leg pulls the life out of a chair or table design.

But how much taper is called for? Too much and the profile can have a stiletto look that even appears structurally compromised. Too little and the leg looks



**Natural inspiration.** As this anatomy study by Leonardo da Vinci illustrates, human legs naturally taper from thick to thin – the same approach often appeals on furniture.



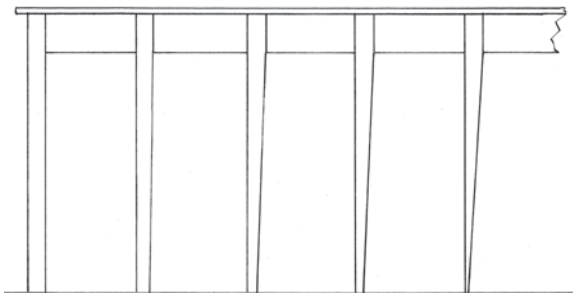

**Progressive tapers.** Sneak up on the right taper; you can trust your eye to proportion this.

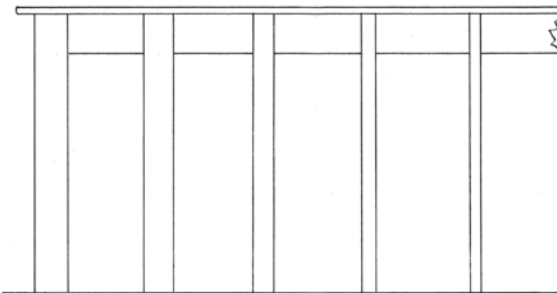

**Thickness.** Which of these legs looks most pleasing to your eye?

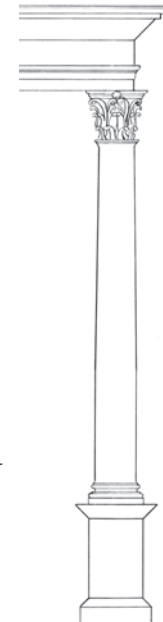

static. I drew up the series of table legs above to illustrate. On the left is a straight leg followed by a series of tapered legs. Which looks most pleasing to you? Here's how much each leg is actually reduced:

- A – Straight
- B – Reduced by a fifth
- C – Reduced by a third
- D – Reduced by half
- E – Reduced by three quarters

I've looked at taper on a large number of built examples and regardless of whether they are simple or an elaborately turned or carved profile, most actually fall into a narrow band. They often reduce by one-third, one-half or slightly less than one-half. By that I mean they might be 2" at the top and 1 1/8" at bottom, or 1 1/2" at top and 13/16" on the bottom. This is a helpful starting point to keep in mind when designing legs, regardless of whether they are turned or square in cross section.

Another source that offers some insight on taper in a vertical element is a classic order. A classic order is an ancient form used in the construction of temples consisting of a column and a support structure above it. The lower third of the column remains constant, then begins to taper inward. Actually it curves in very gradually. This reduction in diameter probably echoes the natural tapering in the tree trunks first used in primitive construction. Usually the column is one-sixth smaller at the top than at the base.

Although furniture legs often taper in the opposite direction, getting smaller toward the floor, it's important to note that a simple taper prevents a vertical element from becoming static and lifeless. As always, take this knowledge and look at built work. File away in your mind what appeals to you as well as what doesn't. If anything, it's more common to see a design

lacking because legs are made too massive. A flag goes up for me when I see a design where the legs look a bit like they've been popping steroids.

### Application

When sketching up a design, it helps to at least begin with a leg envelope that meshes with the overall form. I try to establish both the largest cross section and the taper. To avoid making the legs too massive, I start on the small side with a cross section just able to support the load then bump it up until it starts to gel with the overall mass, as shown above in the "Thickness" illustration.

If you're not confident in your own eye, try this exercise. Sketch out your design with a series of legs that go from thin to bulky. Ask yourself which is too thin to your eye and which is too heavy. You'll surprise yourself with how a leg in between these two meshes with the overall piece. With the mass of the leg established, rough

**Subtle but effective.** The column on this Corinthian order tapers gently from bottom to top by 1/6 of its diameter.

in the taper. Start with a taper that reduces by at least a third and bump it further if necessary. Once that suits your eye, you can turn to detailing the leg.

At this point there are many options. You can add some curvature; it can be turned or carved. But establishing that envelope gives you a good jumping-off spot. You may just build a force of nature, something that comes to be known reverently in your house as "the chair." **PWM**

*George is the author of the DVDs "Unlocking the Secrets of Traditional Design" and "Unlocking the Secrets of Design: Moldings" both from Lie-Nielsen Toolworks.*



**Nice legs.** Tapers and curves are combined on the legs of this Windsor chair to add movement and visual interest.

### Go Online FOR MORE ...

You'll find links to all these online extras at:

► [popularwoodworking.com/dec10](http://popularwoodworking.com/dec10)

**BLOG:** Read more Design Matters on George R. Walker's blog.

**BLOG:** Read about Editor Christopher Schwarz's visit to George R. Walker's shop.

**IN OUR STORE:** George R. Walker's DVDs.

All of our products are available online at:

► [WoodworkersBookShop.com](http://WoodworkersBookShop.com)

### About This Column

If you have a thirst to hone your creative skills, Design Matters dives into the basics of proportions, forms, contrast and composition to give you the skill to tackle furniture design challenges with confidence.



BY BOB ROZAIESKI

# Soup up Your Sawing Savvy

Good practice makes perfect – or at least better.

When it comes to using hand tools, good technique is everything. We can spend hours sawing, chopping and planing, but if we don't practice good technique, all we are doing is getting good at bad habits. To really become proficient with our hand tools, the secret isn't more practice, it's practicing better technique.

Nowhere is this more true than when using a handsaw. So often, the struggles that we have making accurate crosscuts and rips, and sawing joinery, can be attributed to difficulty tracking a straight line. So we buy better saws and practice more, hoping to cut that perfect dovetail. But often, the improvement is only marginal.

It can be frustrating when your skills seem to hit a plateau. But it may not be your fault. You may simply be practicing old, bad habits. Just like anything else, sawing by hand takes practice. But to do it well, it takes proper practice of good technique.

## Equip Yourself Properly

While proper practice is the most important aspect of learning to be a good sawyer, we can't overlook our equipment. It's true that a good sawyer can track a line with a butter knife. But a well-set-up saw, and a proper bench to use it on, will make learning to be a good sawyer much less frustrating.



**Hand-tool workhorses.** In my shop, my handsaws are in constant use. But even if you do all your rough cutting with the help of electrons, you may benefit from a little practice with a long saw.

Most important, your saw needs to be sharp. Also, look at the tooth line. The teeth should be alternately set, or bent, toward either side of the sawplate, so the saw won't bind in the cut. But make sure there's not too much set or the saw will rattle around in the cut. I like my saws set about the thickness of a playing card or two on each side.

If your saw needs sharpening, you can send it out to be sharpened, but be cau-



**Test for sharpness.** If the teeth don't grab the skin of your flattened palm when you try to gently move the saw across it, it's not really sharp.

tious of commercial sharpeners who deal mostly with table saw blades and router bits. Many of them are clueless when it comes to sharpening handsaws and may do more harm than good. Instead, seek out someone who specializes in sharpening handsaws. Better yet, learn to sharpen and set them yourself.

Second, ditch your pencil and get a marking knife, at least for crosscuts. Using a knife instead of a pencil for crosscuts has two advantages. First, by marking the cutline on all four sides of the board with a knife, you reduce the chipping and tearing on the exit side of the cut. Second, if you knife your lines deep and start your saw relatively close to the knife line, the first stroke of the saw will break out the fibers on the waste side of the knife line and the saw will "jump" over right up against the shoulder. This makes accurately starting the cut much easier.

Next, look at your sawbench. If you don't already have a proper sawbench, what are you waiting for? No shop should be without a pair of sawbenches. You'll find a good sawbench design from Christopher



Schwarz in the Autumn 2006 *Woodworking Magazine* (Issue 6) and another from Adam Cherubini in the April 2006 issue of *Popular Woodworking* (#154) (and there are links to these free stories at the end of this article). Pick one and build it.

### Work with Your Body, Not Against It

Believe it or not, our brains have a fairly precise built-in level. However, if we don't position our bodies to use this internal level to our advantage, it can work against us, and lead our saw cuts astray.

When we set up to begin sawing, whether at the vise or over the sawbench, body position has a lot to do with how the

final cut will come out. Our brains naturally want to follow a straight line. To use this to our advantage, we need to line up with the cutline correctly, even if the cutline is not perpendicular to the board face (such as when sawing dovetail pins).

As a right-handed sawyer, if you close your left eye and look only through your right eye, the only thing you should see is the back of the saw (reverse this for southpaws). If you're positioned properly and you can see the side of the sawplate through your right eye, the cut is not plumb.

This natural tendency for the brain to line everything up can work against us if we don't line up properly with the cutline. If we were to stand slightly to the left of the cutline for example, the natural tendency for the brain to line everything up would cause us to pull the heel of the saw out of square and tilt the top of the saw out of plumb. To counter this, we fight our internal level in order to try and fol-

low the line. However, sawing this way is rarely successful or consistent.

### Getting Back On Track

Even if we position ourselves correctly (or think we did), miscuts can still happen. When a cut begins to go awry, immediately stop. To get back on track, first re-adjust your body position in relation to the cutline. Then lower the angle of attack of the saw to the face of the board. Doing so lengthens the kerf and permits minor corrections to the course. Once the cutline has been corrected and is back on track, raise the saw back up and continue cutting along the line.

### Perfect Practice

A great way to practice these sawing mechanics is to make the crosscuts and rips for the secondary parts of your projects, such as drawer sides, bottoms and case backs, using your handsaws. These parts are typically made of softer woods such as pine and poplar, which are easy to saw. These secondary parts also aren't typically seen in the finished piece, so mistakes are easily hidden.

Even if you aren't a hand-tool junkie, sawing with long handsaws once in awhile is the best way to develop the hand-eye coordination and muscle memory needed to become a better sawyer. Practicing good mechanics with longer saws and longer cuts is a skill that directly transfers to your joinery saws, and can help to vastly improve your hand-cut joinery. You may even find it kind of fun! **PWM**

*Bob has been building furniture for almost two decades, and 10 years ago decided to use only hand tools.*



**Make ready.** To saw accurately, grip the handle with a three-fingered grip, point your index finger at the toe of the saw, line up your arm and shoulder with the cutline, and position your eye directly above the saw.



**Take aim.** Like firing a rifle, your right eye should be positioned directly above the back of the saw in order to hit your target. All you should see through your right eye is the back of the saw plate. (Reverse this if you're left-handed.)

**Low and long.** Drop the heel of the saw to lengthen the kerf and correct a cut that begins to drift.



### Go Online FOR MORE ...

You'll find links to all these online extras at:

► [popularwoodworking.com/dec10](http://popularwoodworking.com/dec10)

**WEB SITE:** Visit Bob Rozaieski's web site and read his hand-tool blog.

**ARTICLE:** Read Editor Christopher Schwarz's article on the three classes of sawcuts.

**BLOG:** Read Adam Cherubini's Arts & Mysteries blog.

**ARTICLES:** Read our articles on making a sawbench.

**IN OUR STORE:** "Sawing Fundamentals," a DVD from Editor Christopher Schwarz.

All of our products are available online at:

► [WoodworkersBookShop.com](http://WoodworkersBookShop.com)

BY MEGAN FITZPATRICK

# Victorian Side Table

Pattern routing makes quick and easy work of these urn-shaped sides.

While vacuuming a few weeks back, I was thinking about what to build for this issue's "I Can Do That" project when it hit me ... actually, when I hit it with my vacuum. I've had a small Victorian table/bookshelf in my guest room for years, tucked away in a corner where I rarely see it. It's suffered from a broken foot for as long as I've had it. I decided the time had come to fix the problem so that I could put the table where it belongs – next to my favorite reading chair.

I brought the table into our shop, took a look underneath and realized that, because we've introduced a router to the toolkit, it was ideal for "I Can Do That." So I headed to the big box store for select pine (4' lengths of 1x2, 1x12 and 1x8, as well as a 1/2"-thick piece of pine 4" wide and 4' long – once you get out of the realm of dimensional lumber, the nominal size and actual sizes are the same). I also grabbed a 2' x 2' piece of 1/2" plywood and a can of mahogany gel stain.

## First, Make a Perfect Pattern

There are a great many curves in this piece – while you could use a jigsaw to cut out the sides and feet, then laboriously smooth and sand them with rasps, files and sandpaper, it's far easier to take the time to make one perfect pattern out of 1/4" or 1/2" MDF, hardboard or plywood. We prefer to use 1/2" materials for patterns if we have it handy, because it gives the router bit bearing a wide surface on which to ride.

Take the time to make a good pattern and save it, so you can quickly make a bunch of these tables should you find

**A reader's table.** This Victorian side table is ideal for placement alongside a comfy chair – it has a V-shaped shelf underneath to hold a handful of your favorite books.



yourself in need of a few handmade presents for the holiday season.

I drew the entire side pattern on a piece of 1/2" plywood (with the pattern's straight top edge at the factory edge of the plywood), then cut with a jigsaw about 1/16" outside my lines. No matter how good the blade, the plywood will tear out a bit, so I wrapped sandpaper around a big dowel and used that to clean up the cuts down to the line.

Getting the pattern to look perfect may take some time – but it's worth it. Do it right

(and use a sharp router bit), and you'll have almost finish-ready edges on your workpieces.

## Pattern Transfer

Trace the side pattern twice on your 1x8, then cut with the jigsaw 1/8" or so outside the curvy lines.

While you can set up for pattern routing at this point, I found it easier to first cut the two sides apart (and simultaneously make the straight cut for the top of both pieces) by using the miter saw (or you clamp a straight-edge to guide the shoe of your jigsaw for a straight cut, or simply let the router make the final cut).

Now clamp the pattern in place on one side piece, and install in your router a 1/2" straight bit with a top-mounted bearing. Adjust the depth of cut so that the blade will completely engage your workpiece, and the bearing will ride on your pattern.

For most of the work, make the cuts by moving the router from left to right, or with the direction the router bit is spinning. But as you start to move out of the grain toward the outer edge of the piece, climb-cut – that is, cut against the grain – to avoid breaking off the delicate points. Try to keep moving at a steady pace; if you



**Trace amounts.** Trace your pattern two times on your 1x8; try to keep the grain figure centered and continuous for a good look.



leave the blade in one location for too long, you'll burn the edge of your workpiece (not a big deal – it can easily be sanded out). Also, you'll get a cleaner edge if you make one pass to remove the bulk of the waste, then ride the bearing along the pattern as you make a final light pass to cut the final shape. Do the same on the second side.

### Strong Feet

You'll notice in the illustration that the feet are separate from the sides. It's important that the grain runs across the feet so that the 1½" ends don't snap off (which is exactly what happened to my antique inspiration piece). You can make a pattern and use a router to cut the feet from the end of your 1x12, but because they are simple curves, I just drew them directly on the pine, cut them with a jigsaw then sanded them.

Attach the feet to the sides with three countersunk screws—a 2" one in the middle of each foot, and 3" screws located 1½" or so to each side of center (I eyeballed it; there's no need to measure).

### Shelves & Top

The shelf cleats are simply a ¾"-thick, 3¾"-square piece, cut in half diagonally. They're secured by three 1¼" countersunk screws in each. The two 20" shelf pieces are cut from the ½" stock and are simply butted together at a 45° angle then secured to the cleats with three nails per end. (Don't forget to drill pilot holes.)

Cut the top cleats from the 1x2 and before screwing them down to the top of each side, round the ends with a rasp and sandpaper.

Cut the top to size, and if you like, add a decorative profile on the top edge using a ¼" roundover bit (or any profile you like.)

I stained this piece with two coats of gel stain before attaching the top, and added a top coat of wipe-on poly for protection. (Gel stain sits on top of the wood more than traditional, penetrating stain, so it cuts down a bit on the blotching inherent to pine.)

With the finish done, flip the top over, position the cleats, drill countersinks and drive 1¼" screws through the cleats into the underside of the top to secure it.

Now, choose a selection of your favorite books and stock the shelf. You're ready to read. **PWM**

Megan is managing editor of this magazine; she has yet to fix the inspiration piece for this project.

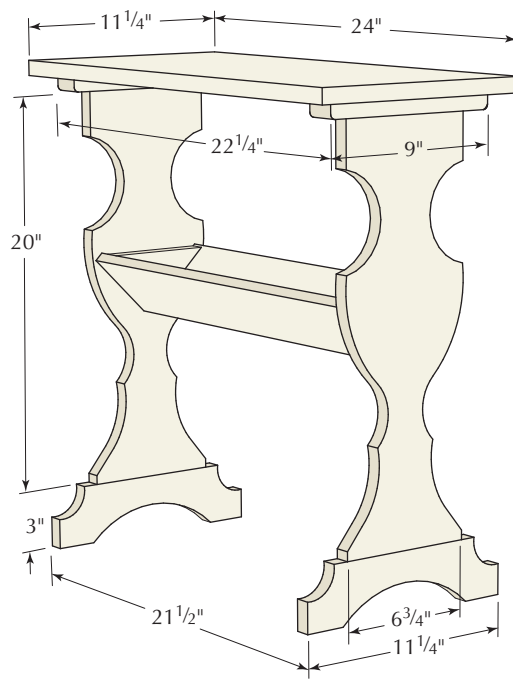

3-D VIEW

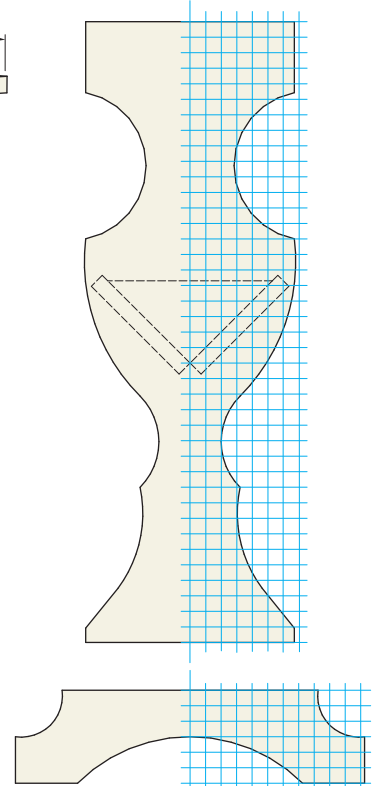

SIDE & FOOT PATTERNS

### Victorian Side Table

NO.	ITEM	DIMENSIONS (INCHES)		
		T	W	L
2	Sides	¾	6¾	20
2	Feet	¾	3	11¼
1	Shelf cleat	¾	3¾	3¾
2	Shelves	½	4	20
2	Top cleats	¾	1½	9
1	Top	¾	11¼	24



**Ready to rout.** Grab your router and before you plug it in, install a ½" straight bit, then adjust the depth of cut so that the blade hits your workpiece and the bearing rides on your pattern.

### Go Online FOR MORE ...

You'll find links to all these online extras at:

► [popularwoodworking.com/dec10](http://popularwoodworking.com/dec10)

**PLAN:** Download the free SketchUp plan for this project.

**ARTICLES:** All the "I Can Do That" articles are free online.

**IN OUR STORE:** Online and DVD video instruction on woodworking basics.

Download the complete "I Can Do That" manual:

► [popularwoodworking.com/icandothat](http://popularwoodworking.com/icandothat)

All of our products are available online at:

► [WoodworkersBookShop.com](http://WoodworkersBookShop.com)

### About This Column

Our "I Can Do That" column features projects that can be completed by any woodworker with a modest (but decent) kit of tools in less than two days of shop time, and using raw materials that are available at any home center. We offer a free online manual in PDF format that explains all



the tools and shows you how to perform the basic operations in a step-by-step format. Visit [ICanDoThat.com](http://ICanDoThat.com) to download the free manual.

# Line & Berry Chest of Drawers

BY GLEN D. HUEY

Though not traditional, router patterns make quick work of the inlay.

In southeastern Pennsylvania, just northwest of Philadelphia, is Chester County. It was one of the original three counties formed by William Penn in 1682, under a charter signed by King Charles II. In 1729, a large portion of the western county was split off to become Lancaster County, and in 1789, the southeastern townships closest to Philadelphia were organized as Delaware County. That left Chester County as we find it today.

Throughout the 1700s, Chester County furniture makers produced pieces with unique surface decoration, such as the line and berry inlay shown on this chest. Furniture makers of the period scribed inter-connected half-circles into the surface. The design was scratched using a compass, which is why the process is often referred to as “compass inlay.” Sometimes, at the termination of those circles, small groupings of round berries completed the design. This decoration reached a popularity peak in the 1740s.

## Where to Begin?

The striking feature on this chest is the inlay on the drawer fronts—but the chest, on its own, has attributes not often seen in furniture construction.

Begin by prepping the panels for the case sides and bottom. Notice that there is a difference in the widths of these components. The  $\frac{5}{16}$ " offset allows for the added double-bead moulding on the case sides and drawer blades, a common feature during the William & Mary period. That offset is at the front of the chest, so when trans-



**Inlay gets noticed.** This arresting, seemingly complex inlay is accomplished using a router and series of patterns.

ferring your dovetail layout, work with the rear edges of the panels aligned.

There is quite a bit of work needed on the case sides. Dovetails join the sides to the case bottom and single sockets hold





the support rails, both front and back. From a pins-first point of view, set your marking gauge to  $\frac{5}{8}$ " and scribe the two case sides along the bottom edge. Why  $\frac{5}{8}$ " when the thickness of the bottom is  $\frac{3}{4}$ "? It's to hide the dovetail joints when the base pieces wrap the chest. Lay out and cut the pins in the case sides.

With the pins complete, mark the case bottom where the front edge of each side ends. Chuck a straight bit into your router, set the depth of cut for a shallow rabbet that leaves  $\frac{5}{8}$ " of material and clamp a fence even with the inside layout line. Now make the cut from that mark to the back edge of the bottom on both sides. The rabbets help register the sides to the bottom and provide a more accurate transfer of the pin layout. Cut the tails at both ends of the bottom and fit the joints. Tweak the fit as necessary.

After the dovetail joints are fit, lay out and cut four sockets at the top of the sides, along the front and rear edges. The tails for the support rails slip into the sockets from the top down. The front support rail fits  $\frac{7}{16}$ " behind the front edge of the sides; the rear support rail is set flush to the backboard rabbet, or  $\frac{3}{4}$ " in from the rear.

### Slide-in Blades

The drawer blades attach to the case sides with sliding dovetails. Lay out the sockets along the front edge of each case side and on the back edge for the one rear blade, making sure that each location matches its counterpart in the opposite side—you want the blades to be level across the front of your chest. Slide a  $\frac{3}{4}$ " dovetail bit through a  $\frac{3}{4}$ "-outside-diameter guide bushing, then chuck these in your router. Position the platform to the left of the socket area as shown in the top right photo, then cut the  $\frac{1}{2}$ "-deep x  $2\frac{1}{4}$ "-long sockets. (Read more about this technique in the November 2008 issue of *Popular Woodworking*, #172.)

For the backboards, cut a  $\frac{7}{16}$ "-deep by  $\frac{3}{4}$ "-wide rabbet along the rear edge of the case sides. Now the work on the sides is complete.

Next, mill your drawer blades, front top rail, support rails, vertical divider and drawer runner stock to thickness and size. To get exact lengths, measure off of your assembled case. The blades' lengths includes the two dovetails, as do the support rails. The top front rail runs from outside edge to outside edge.

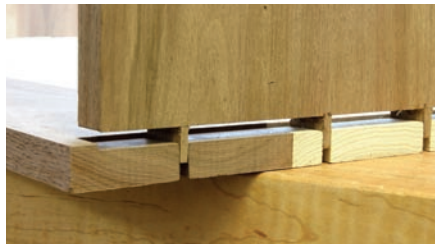

**Disappearing joinery.** Form the tails in the case bottom after you cut a rabbet  $\frac{1}{8}$ " below the inside surface. This allows the base moulding to cover the dovetail joint.

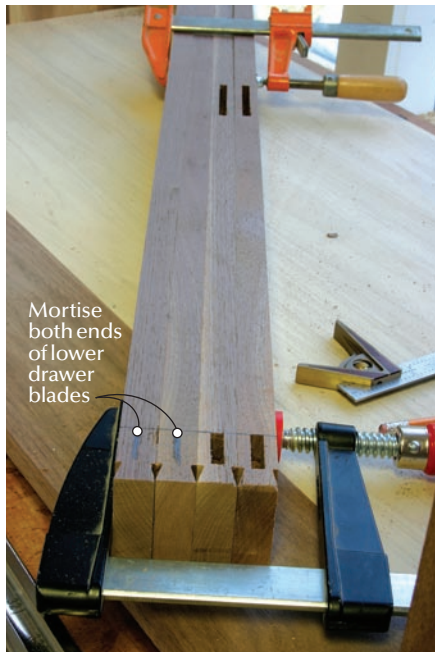

**Strong connections.** The top and rear blades are mortised for the housed and center runners. The lower drawer blades have a single mortise cut at each end to hold the runners in position.

Dry-fit the sides and bottom, position the support rails to the sockets cut in the sides, then transfer the layout onto the rails. Trim the ends then fit the rails to the case—be sure to mark front or rear. The drawer blades get the tail portion cut into both ends. Do this with the same dovetail router bit used to create the sockets. Install the bit in your router table and adjust the cut height first, then set the fence to cut the sliding tail to fill the socket. (It's best to test the setup using a scrap of the proper thickness of stock.) To complete the work on the blades, lay out and cut mortises for the runners.

### A Runner to Ride On

The next step is to assemble the case. Apply glue to the bottom, sides and dove-

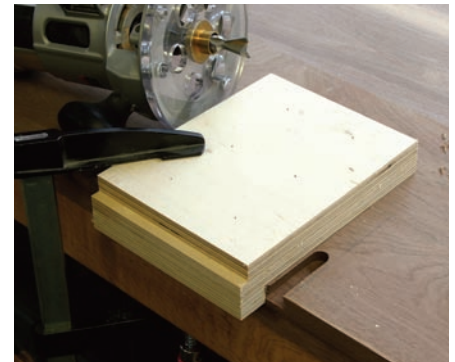

**Best router setup.** A platform jig,  $\frac{3}{4}$ "-dovetail router bit and a  $\frac{3}{4}$ "-outside-diameter guide bushing are used to create the sliding dovetails that attach the drawer blades to the case. It's simple.



**Want to make it easy?** All the joinery work on the center divider is hidden—covered by the mouldings or the top. To make quick work of the divider, attach the piece to the blade and support rail with screws.

tails, and slip the joints together. For the front blades (leave the rear blade floating), apply a dollop of glue at the front of each dovetail slot then add a thin coat on the tail before slipping the blade into position. A light touch with a mallet should set the blade flush with the front edge of the case sides—that's a correct fit.

In the center of the front support rail, cut a through-mortise that's  $\frac{1}{4}$ " wide and  $1\frac{1}{4}$ " long (oriented front-to-back) for the center divider. Take a look at the photo above. The divider has a unique shape because the top notches around the front top rail as the tenon fits through the sup-

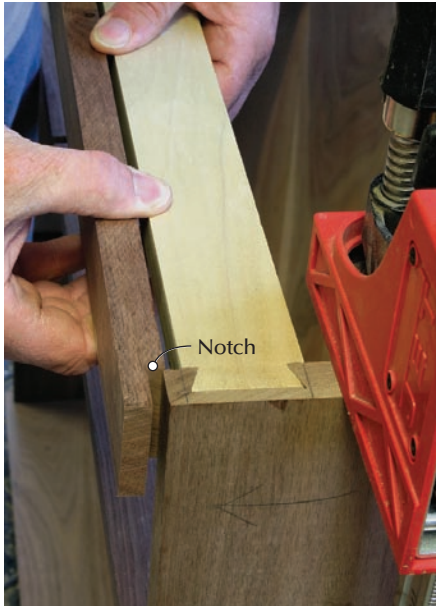

**Built out to match.** Here you can see exactly how the front top rail fits with the support rail to bring the front edge equal with the case bottom. The notches at the ends of the rail are nibbled away at the table saw.

port rail. The divider is joined at the bottom with a 1/4"-thick dovetail that slips into the top blade. That's a lot of work. If you want to simplify the process, a couple screws through the rail and blade make this quick.

With the center divider ready to install, add glue to the joinery, including the sockets in the case sides and the dovetails on the support rails, then slide it all together. The front top rail fits tight to and is glued to the support rail and wraps over the case sides, building out the 5/16" to match the case bottom. The notches are cut at the table saw.

Cut tenons where needed on the ends of the runners. The housed and center tenons each get a 1/4" tenon at the front and a 1" tenon at the back. Glue the tenons in position (the rear tenon is not glued, which allows for seasonal movement) square the runners, then nail them to the case side.

*"The person interested in success has to learn to view failure as a healthy, inevitable part of the process of getting to the top."*

— Dr. Joyce Brothers (1928 -)  
psychologist, actress



**Set for change.** The bottom drawer runs on the case bottom and the top bank of drawers rides on housed runners. The middle runners, to allow for seasonal changes, are attached to the case side with cut nails.



**Left-hand stop.** The magnetic stop set to the left of the material is used to precisely align the moulding profile with the saw blade. Push the stock tight to the auxiliary stop then pull the table saw fence tight to the stock before ripping.

### Keep Your Bevels Sharp

Except for the bottom and front top rail, the front face of the chest is covered with a double-beaded moulding. Use a traditional beading bit to form the twin beads. The setup for the beaded moulding requires accurate adjustment to get the beads evenly spaced without the second pass cutting into the first bead. Once set up, create the profile on a wide board that's milled to the proper thickness. Slice the moulding from the board then produce another set of mouldings until you have the pieces needed.

Use blue tape to hold the moulding pieces to the case sides then use a chisel to mark the exact location where the blades meet the sides. From those marks, draw lines along the back of the moulding at a 45° angle to show the waste area that's removed to accept the end of the blade mouldings.

Saw as much of the waste out as you

can without working past the lines then pare exactly to the lines. To keep the edges square and the angle correct so the perpendicular moulding fit is tight, use a simple V-shaped guide block. Pare the V-shape until the chisel rides the guide block.

The bead mouldings that cover the blades have pointed ends to fit the V-shaped cutouts. Form the ends just as you did on the side mouldings. That's easy. The trick is to get an accurate cut length. It's best to cut it long then pare to a good fit. The center-divider moulding is cut square, to fit against the front top rail.

To attach all the mouldings, add a thin bead of glue to the back of each then secure the pieces to the case with blue tape. Add a few inconspicuous 23-gauge pins to help keep pieces from moving.

### Simple & Solid Base

The base for this chest is as simple as it gets. Mill the pieces to thickness and size





**Accuracy is important.** A sharp chisel marks the beaded moulding exactly at the place the V-shape is to be cut.



**Back up that cut.** The V-shaped notches that accept the drawer blade bead moulding need to be perfectly cut, as do the mouldings. Use a backer with a 45° opening cut made at the table saw to pare them.



**Form the foot.** Use a 1<sup>3</sup>/<sub>4</sub>" Forstner bit to clean out the rounded portion of each design that forms the spur. Then at your band saw, cut away the remaining waste.



**Work on your bench.** Use scrap 8/4 to raise the chest off your bench and make fitting the base that much easier. One piece at each corner does the job.

before adding your favorite profile along the top edge. Next, miter the pieces to length using the chest as your guide. The top edge of the base is flush with the top edge of the case bottom. After the pieces are fit, trace the cutout profile at each end of the three pieces and draw a line connecting the profiles.

The base pieces have a thin bead of glue along the top edge and are attached to the case using cut nails. To keep glue squeeze-out to a minimum, cut a shallow groove on the back face of the base approximately 1/4" down from the top. Align the front piece to the chest then add a couple clamps to hold it in place and tight to the chest. Add glue along the front 6" of the base side, position that piece to the front piece and tack it in place with a 23-gauge pin. Work the second side, too.

Next, remove the front piece, add glue

along the top edge and on the miters, then clamp it back in place. Pin the mitered corners to keep them aligned until the glue sets. For an authentic look, drill pilot holes and install cut nails in the base, with the nails set just below the surface.

To complete the base, slip the rear feet in position and reinforce the corners with glue blocks. The chest actually stands on the blocks, which extend slightly beyond the base. Glue blocks should also be installed along the base/bottom intersections behind the feet.

The top is attached to the chest with #8 x 1 1/4" wood screws through the support rails (screws in the rear rail should be in oversized holes) and two wooden clips per end that are evenly spaced between the rails. I cut the 1/4" slots for the clips with a plate joiner; screws hold the clips in place.

The underhung moulding is made at a router table with the lower portion of a specialty moulding router bit (Rockler # 91881). With a wide board stood on its edge, create two profiles then rip the mouldings at your table saw. The moulding is attached to the chest just as the base is – glue and square-head nails.

## Supplies

**Ball & Ball**  
ballandball.com or 610-363-7330

8 ▶ A69 backplate with A72 drop on post #A000-000, \$26.47 each

5 ▶ 1<sup>3</sup>/<sub>4</sub> x 1<sup>3</sup>/<sub>4</sub> Wm & Mary chased, cast escutcheon #L61-002, \$17.12 each

*Prices correct at time of publication.*

## Patterns Make Repeating Easy

With the chest assembled, mill and size the drawer fronts to fit the openings – these are flush-fit drawers so keep the reveals at a minimum ( $\frac{1}{16}$ " or less). Depending on your preference, at this time either build the drawers or work on the inlay for the drawer fronts.

The drawers are built using 18th-century construction techniques – half-blind dovetails at the front and through-dovetails at the rear. The drawer backs are sized so the drawer bottoms slide under the backs. The bottoms are beveled to fit into  $\frac{1}{4}$ " grooves in the drawer sides and front – the tops of those grooves are cut  $\frac{3}{4}$ " above the edge. Cut a slot in the drawer bottoms even with the inside edge of the drawer back. Nails driven through the slot

and into the drawer back secure the bottoms and allow for seasonal movement.

Patterns for the string grooves can be created from a design you already have in mind – or use the plans included here on page 39. To make your own patterns, create a design in a full-size drawing (Google SketchUp is great for this step). Next, select a guide bushing size (for this piece, I used a  $\frac{3}{8}$ "-outside-diameter bushing) and offset the lines to compensate for the bushing. Transfer your new lines to  $\frac{1}{4}$ " plywood then cut out the patterns. Plywood thicker than  $\frac{1}{4}$ " causes problems with the bit length when cutting the grooves.

For this project, three patterns were developed. The included patterns are sized for the top drawers. Because the drawers are graduated, make a second set of

patterns (20 percent larger) for the lower three drawers.

Each of the inlay designs is created around a center point. That point is established using one of the top drawers. Find the exact center of the drawer front then measure from the edge of the drawer front to that center point. Each drawer inlay design, whether on the right or left of the drawer, is set to that measurement – all the designs line up vertically on the chest. For the top drawer, draw vertical lines that are equally spaced  $2\frac{3}{16}$ " off the center point (the line spacing for the larger drawers is  $2\frac{11}{16}$ "). Also draw a line horizontally as shown in the photo below.

Begin with the twin-bump-shaped pattern. Set the pattern square to the drawer front with the valley of the bumps set at



**Proper layout.** The design of the drawer fronts is dependent on getting your layout right. Space the lines off each drawer's center to keep the designs aligned.



**Keep it straight.** The jigs used in this project are all held square to the drawer front. Proper placement is essential to the task.



**That's step one.** These are the first set of lines in the design. The depth should be a strong  $\frac{1}{16}$ " for a secure fit that's easily trimmed after installation.

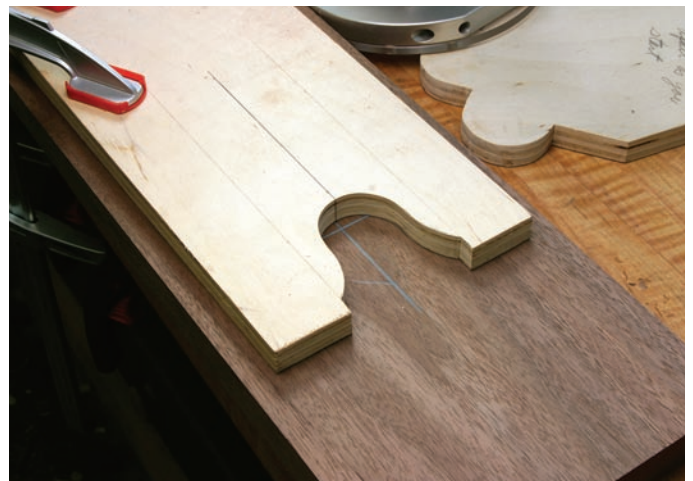

**Accurate placement.** After the jig is properly placed, the two flat steps at the top of the tulip are where the router guide bushing begins and ends. The bushing snaps into the corner.



the intersection of the horizontal centerline and one of the  $2\frac{3}{16}$ " lines. Point the bumps toward the drawer center.

With the guide bushing and a  $\frac{1}{16}$ " straight bit chucked in the router, and the bit set to cut a strong  $\frac{1}{16}$ " into the fronts, locate the bushing at the top end of the pattern, plunge the bit into the drawer front then rout the design. Stop when the bushing hits against the pattern's flat step, completing the pattern. Repeat the steps with the pattern set to the opposite lines, again facing the center.

The second pattern is the tulip design. Place this pattern squared to the drawer front with its top-to-bottom center aligned with the drawer front's centerline. The pattern is also aligned with the outer edge of the twin-bump routed line as shown in

the bottom right photo on the opposite page. Begin with the bushing located at one of the corners. Plunge into the wood then rout through the tulip shape until the bushing nestles into the opposing corner.

The next two steps of string routing are the most difficult. To locate the wave pattern, you need to lay out a couple lines as shown in the top right photo below. The first line is squared off the drawer front and aligned with the ends of the tulip design. The next line toward the center is half the width of the guide bushing being used. It's used to set the wave pattern square to the drawer front and just at that inside line.

This time, fully plunge the router off the pattern then place the router bit to drop into the tulip line, right at the end.

Hold the bit out of the wood and the bushing against your pattern as you start the router then allow the bit to settle into the router then allow the bit to settle into the tulip line. Rout to the center of the pattern then back out toward the second end of the tulip design. When you get to that second line, stop your movement and release the plunge on your router. As you repeat this process for each inlay design, you'll develop a feel and ear for it – you'll hear a different sound as you break into the second line. But on the first couple passes, watch the router bit as you move.

The last bit of pattern work is to reverse the wave pattern and cut in the pointed end. To locate the pattern, measure along the drawer centerline out from the valley of the wave line and place a mark at 1" for the top drawers and  $1\frac{1}{4}$ " for the other



**Step two.** The completed tulip design faces away from the drawer center and is spaced just outside the bump design.



**Plunge to begin.** The tulip top string groove is the first of two grooves that require that you see the bit as you work – or develop a feel for when to stop at the line.



**A simple reversal.** Flip the wave pattern then set the distance between the pattern and the previous groove at 1" for the two top drawers and  $1\frac{1}{4}$ " for the lower drawers.



**It's all in the base plate.** The arcs around the center of the design are cut using the router base plate as a circle-cutting jig. Place a dowel into the drawer front's centered hole, slip the router plate over the pin then cut the groove from bump to bump.

drawers. Again, the valley of the wave sits at the intersection. Routing the line is a repeat performance, but on a smaller scale.

The center grooves are cut with a circle-cutting setup. Drill an 1/8" hole at the center of the inlay design. Due to the diameter of the circle being so tight, I simply drilled a 1/8" hole in the router's base plate, set to cut from pattern to pattern. For the top drawers, the radius is 1 11/16" and on the other drawers the radius is 1 15/16". Rest the bit in one of the routed grooves, start the router and rotate it to cut the arced groove. Stop the cut as you reach the opposite string groove. Repeat the steps for the second arc.

### Finally, String & Berries

There are straight grooves for inlay, too. The small section between the bumps and the tulip can be routed or you can use a regular screwdriver to punch the surface just deep enough for stringing. The other straight grooves are around the entire perimeter of each drawer. This line is routed using a fence attached to your router. Space the grooves 7/8" from the outside edge of the drawers.

Traditionally, string used in Chester County furniture was made of holly for its white appearance, but I have oodles of scrap maple lying around my shop. That's what I chose for my string. (You can also purchase string material.)

String inlay needs to be sized to fit your grooves. Mill a piece of scrap that's about 3" wide into pieces that are a strong 1/16" thick then rip thin strips from the wider stock – a cutting gauge is ideal for this work.

After the string is made, it's necessary to size each piece. The best method for sizing the string to an exact fit is at your spindle sander. Fit the string between the fence and the drum while pushing into the rotation of the drum. Test the fit. If it's good, you're good. If not, adjust the fence and try it again.

Straight pieces are ready to fit. Miter the corners and, unless your stock is plenty long, use scarf joints to hide additions. The curved pieces are another story. I've tried a variety of methods to bend stringing, but the best I've found is to heat-bend the pieces on a pipe that's heated with a torch. For the larger-diameter curves created with the bump pattern, a 2"-diameter



**Sized right.** Clamp a fence at your spindle sander to perfectly size the stringing thickness. Run a sample. If the fit is too tight, adjust the fence and try the setup again.

## Line & Berry Chest of Drawers

NO.	ITEM	DIMENSIONS (INCHES)			MATERIAL	COMMENTS
		T	W	L		
❑ 1	Case bottom	3/4	20 <sup>13/16</sup>	39 <sup>1/2</sup>	Poplar/Walnut	
❑ 2	Case sides	3/4	20 <sup>1/2</sup>	35 <sup>3/4</sup>	Walnut	
❑ 3	Drawer blades	3/4	2	39	Walnut	
❑ 1	Rear blade	3/4	2	39	Poplar	
❑ 2	Support rails	3/4	1 <sup>3/4</sup>	39	Poplar	
❑ 1	Front top rail	3/4	1 <sup>3/4</sup>	39 <sup>1/2</sup>	Walnut	
❑ 1	Center divider	3/4	2	9 <sup>1/8</sup>	Walnut	3/4" TBE*
❑ 1	Center runner	3/4	2 <sup>3/4</sup>	16 <sup>7/8</sup>	Poplar	1/4" TOE**, 1" TOE
❑ 1	Drawer guide	5/8	3/4	15	Poplar	
❑ 2	Housed runners	3/4	1	16 <sup>7/8</sup>	Poplar	1/4" TOE, 1" TOE
❑ 4	Runners	3/4	1	18 <sup>1/4</sup>	Poplar	1/4" TOE
❑ 2	Kickers	3/4	1	9 <sup>3/8</sup>	Poplar	
❑ 1	Top	3/4	21 <sup>11/16</sup>	41 <sup>1/16</sup>	Walnut	

### MOULDINGS & BASE

❑ 2	Side beads	5/16	3/4	33 <sup>1/4</sup>	Walnut	
❑ 3	Blade beads	5/16	3/4	39	Walnut	
❑ 1	Divider bead	5/16	3/4	6 <sup>7/8</sup>	Walnut	
❑ 2	Underhung mouldings	5/8	1 <sup>1/4</sup>	44	Walnut	
❑ 1	Base front	3/4	6 <sup>1/4</sup>	41	Walnut	
❑ 2	Base sides	3/4	6 <sup>1/4</sup>	21 <sup>9/16</sup>	Walnut	
❑ 2	Rear feet	3/4	5 <sup>1/2</sup>	6 <sup>1/8</sup>	Poplar	

### DRAWERS

❑ 2	Top fronts	3/4	6 <sup>5/8</sup>	18 <sup>5/8</sup>	Walnut	
❑ 1	#2 front	3/4	7 <sup>3/8</sup>	38	Walnut	
❑ 1	#3 front	3/4	8 <sup>1/8</sup>	38	Walnut	
❑ 1	Bottom front	3/4	8 <sup>7/8</sup>	38	Walnut	

\*TBE = tenon both ends, \*\*TOE = tenon one end



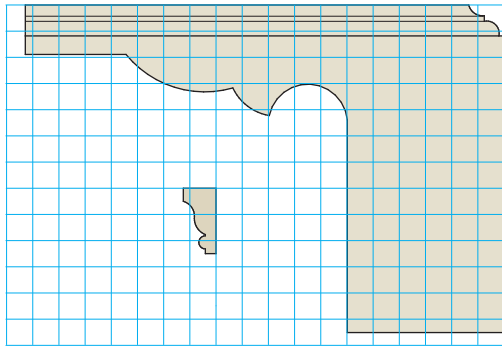

1 grid square = 1/2"

FOOT & TOP MOULDING PATTERNS

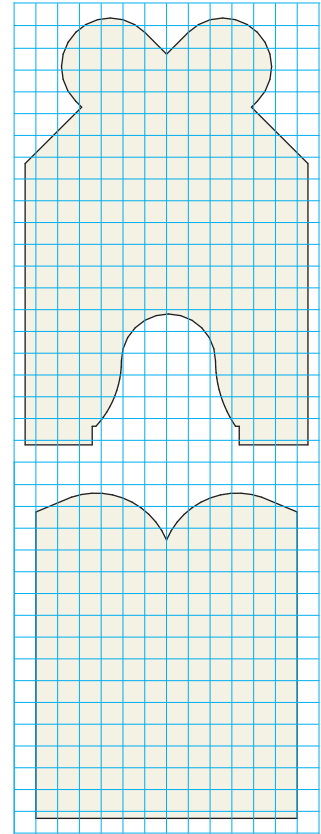

1 grid square = 1/2"

ROUTER PATTERNS

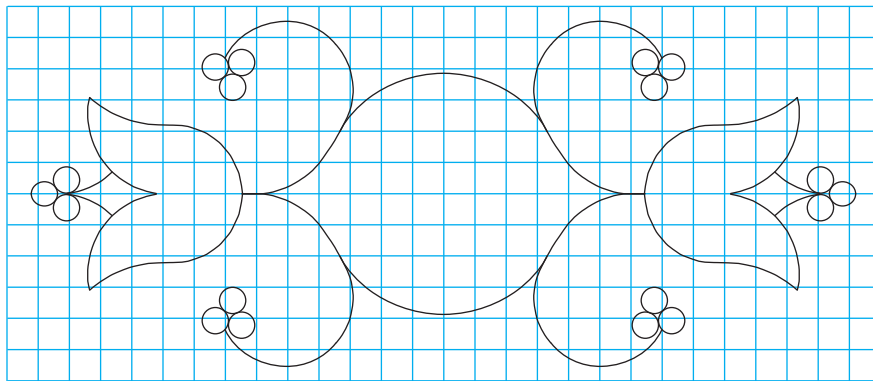

1 grid square = 1/2"

INLAY PATTERN

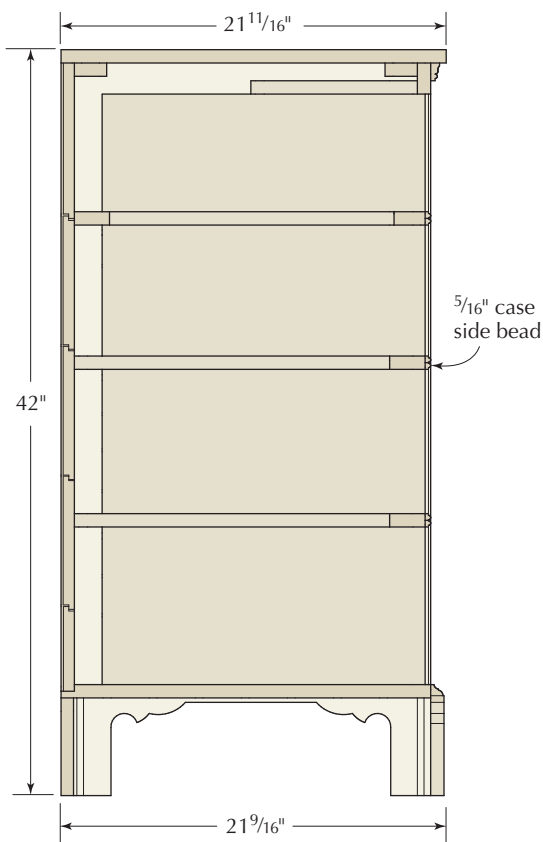

SECTION

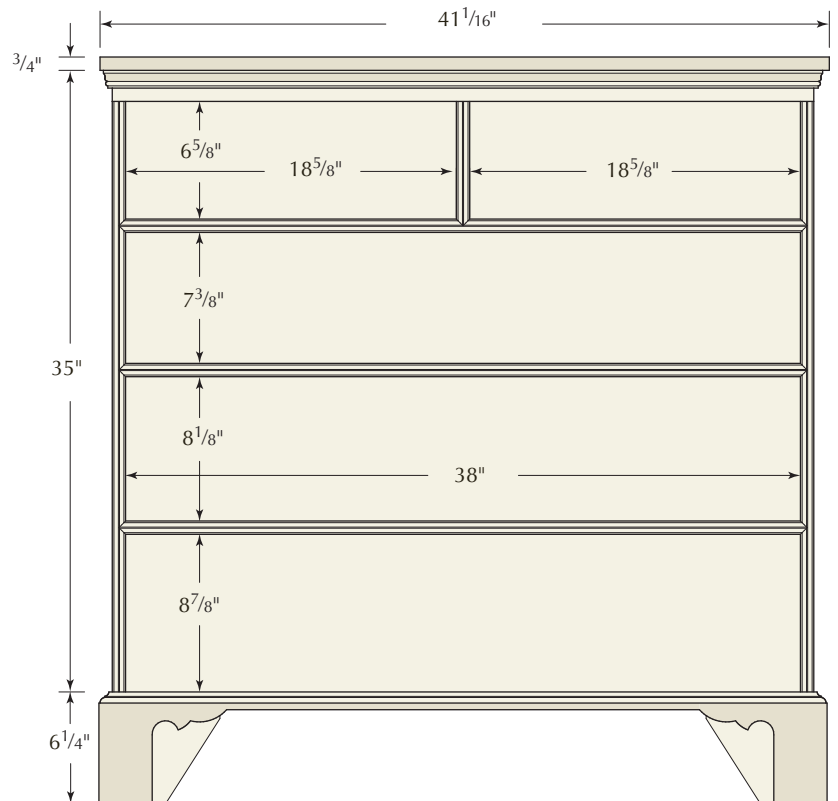

ELEVATION

**Hot pipes.** The heat from the torched galvanized pipe steams the water and dries the string at the shape needed to fit into the grooves. It's always good to have pipes of various sizes on hand.



piece of galvanized pipe works perfectly; 1 1/4" pipe is ideal for the tulip area.

Heat the pipe until it's hot but not scorching hot – a couple test pieces should clue you to what temperature is best. Lightly wet the string then, using a backer strip such as a piece of pallet banding, bend the string around the heated pipe.

Fit the string to the grooves and don't sweat the areas where the string ends. Those spots get berries to cover the raw ends. The place to work meticulously is where two pieces of string meet. The tighter the fit, the nicer the look. However, as with dovetails, a few imperfections says "handmade."

A few small dabs of glue along the groove keep the string in place. As you tap in the string, the glue chases around the groove. Wipe off any excess when all the string is placed.

The berries are where you become the artist. On the original, each berry cluster – most likely made from red and white cedar – was set with the two berries that touched the vine perfectly aligned with the length of the drawers. A third berry was placed directly at the center while just touching the other two berries. The sym-

## Working With Inlay Bits

A 1/16" router bit is used to create the grooves in the line and berry design found on Chester County furniture and elsewhere. Bits available through most suppliers have 1/4" shanks and the cutting length is a short 1/4" at most.

Two potential problems arise when using these bits in string inlay work. First, the cutting length is too short so as not to allow ample depth of cut for your stringing if you push through a guide bushing and beyond a plywood pattern, as we're doing with this project.

Second, the 1/4" shank, when extended enough to reach through the above-described scenario, requires that you use a larger guide bushing than the 3/8" bushing used for the chest – the inside diameter of the bushing is only slightly larger than the shank diameter, so without spot-on setup, the bit has the potential to rub the bushing. What to do?

The first and most simple fix is to use a larger-diameter guide bush-

ing. Working with a larger-diameter bushing reduces the crispness of the design, but allows the bit's shank to easily pass through the guide bushing as the router bit tip reaches your drawer front.

You can also use thin pattern material. With less thickness to pass by, your bit doesn't have to extend as far to cut the grooves. (Remember, it's OK to shorten the length of the guide bushing to make everything work.)

Another option is to use a 1/8"-diameter router bit in conjunction with a collet reducer. This setup (as shown in the photo) allows you to extend the collet reducer beyond the router's collet and if you pull the 1/8" router bit out of the reducer to its fullest extent, the bit's reach is enough to create the grooves without adjustments to either the bushing or your pattern.

One source for the 1/16" straight bit is [inlaybandings.com](http://inlaybandings.com); collet reducers can be found at [IMService \(cadcam.com\)](http://IMService.cadcam.com).



**Stretching the point.** Collet reducers, chucked into regular collets, can help to lengthen a router bit's reach.





**Take your time.** With the stringing bent to closely match the grooves, begin at one end of the run then work to the opposite end. String left in the groove tends to hold its shape better. As you glue the pieces in place, work again from end to end of the groove.



**Berry nice.** The placement of the berries is left to your discretion. I think it's best to have the berries overlap and appear like clusters of grapes on the vine.

metrical look was very regimented.

My take is to lighten up. I randomly located the berries that touched the vine, and made sure the two lapped, as did the third when it was installed. To do this, you have to install a single berry at a time. Drill an  $\frac{1}{8}$ "-deep x  $\frac{3}{8}$ "-diameter hole at each berry location.

The berries themselves are face-grain plugs, either shop-made or store-bought. Dab glue in the hole then tap in the berry. Use a chisel to flush the berry to the drawer front prior to drilling and installing the second and third berries. I used two cherry berries and a single maple berry for each of my clusters. The choice is yours.

### At the Finish Line

With the drawers and drawer front inlay complete, the only woodworking left is the chest back. The backboards run from side to side and fit one another with a tongue-and-groove joint. Each board is nailed with a single nail at each end; the top board has two nails per end.

As for the finish on the chest, stain or dye would reduce the contrast of the string against the walnut background. So, to achieve a deeper color in the walnut while highlighting the string, apply a coat of boiled linseed oil. Follow that with a layer of clear shellac once the oil is dry. From there, I sanded the clear shellac then added multiple layers of amber shellac – the amber color warms the walnut,



**It's a perfect match.** The face-grain plugs that become berries are fit into holes drilled with a  $\frac{3}{8}$ " drill bit. Because of the flat-grain to flat-grain gluing surfaces, the berries will stay put.

but also colors the other woods – sanding between coats to smooth the walnut grain. Once I achieved the color I wanted, I returned to clear shellac in order to build a smoothed surface. I thoroughly sanded the shellac before spraying a layer of dull-rubbed-effect pre-catalyzed lacquer to dull and further protect the surface.

After the hardware is added to the drawers (I ordered post-and-nut equipped pulls instead of snipe pins), the chest is ready for use. Mine is going into my bedroom, but you might just want this piece in a high-visibility area. It commands attention. **PWM**

*Glen is senior editor of Popular Woodworking Magazine and teaches woodworking classes and seminars. Contact him at 513-531-2690 x11293 or [glen.huey@fwmedia.com](mailto:glen.huey@fwmedia.com).*

### Go Online FOR MORE ...

You'll find links to all these online extras at:

► [popularwoodworking.com/dec10](http://popularwoodworking.com/dec10)

**ARTICLE:** A router makes quick work of the door inlay for a spice box Glen built in 2001-2002.

**WEB SITE:** Discover more about Chester County furniture.

**IN OUR STORE:** November 2008 Popular Woodworking (#172).

**TO BUY:** Ready-made string and other inlay supplies.

**IN OUR STORE:** Steve Latta's DVDs on traditional methods to make line and berry inlay.

All of our products are available online at:

► [WoodworkersBookShop.com](http://WoodworkersBookShop.com)

# Cross-grain Solutions

BY ALAN TURNER

Methods to prevent cross-grain splits in traditional solid wood case construction.

What is obvious to the seasoned furniture maker often escapes the attention of the newer, aspiring maker. This is especially true when it comes to recognizing and avoiding cross-grain wood movement problems. Wood moves seasonally due to the ability of warm summer air to hold a far greater amount of moisture than cold winter air.

In Philadelphia, we are 60 miles from the ocean and we see the equilibrium moisture content (EMC) of wood at about 6 percent in February and approximately 12 percent in early September. This change from winter to summer causes wood to swell across the grain, and this can easily cause splitting in solid wood parts.

Several trips to the Philadelphia Museum of Art to examine pieces in storage, and in its furniture conservation lab, revealed a number that had experienced some level of failure due to cross-grain construction methods, inelegant cross-grain solutions, or had fallen victim to modern systems of climate control.

Museum conservator Christopher Storb argues that the 18th-century fur-

*"It is a mistake to think you can solve any major problems just with potatoes."*

— Douglas Adams (1952 - 2001)  
British humorist author



**Stack them up.** Hot hide glue makes quick work of gluing up a sandwich of corner blocking segments. This tactic prevents the bracket foot from splitting over time.

niture we examined was built well for its time, but that the advent of dry, centrally heated buildings, coupled with poorly conceived repairs, are at least as much at fault as original design flaws.

## Solid Cases with Drawers

Many early pieces were built using solid wood – a slab-sided dovetailed carcass. Having the sides, top and bottom with the grain running in the same direction, works well with itself. But when you introduce drawers to the mix, issues arise. Drawers

typically run on rails and need to be supported for their entire length.

Many 18th-century case pieces use a solid wood dust panel immediately behind the primary wood drawer blade. In American pieces, poplar was often used. To avoid the problem of running a drawer rail from front to back (and thus cross grain to the case side), the makers introduced a failure-prone element, a solid wood dust panel sitting at 90° to the direction of the drawer movement. With the drawer sliding across the grain, quick wearing of the poplar was





**View from the back.** Here is the rear of a drawer web frame with the rear tenon's shoulder cut short and left unglued to accommodate movement of the solid wood case side.



**Old nails.** The return moulding is nailed to the case side. There is no splitting so it appears that the old nails were still in use and had not been replaced with modern ones.

often the result. A different solution was to use a hard maple drawer web frame mounted in a stopped dado.

When building a carcass, your solid wood choices are a single plank (or glued up panel of solid wood), or frame-and-panel construction. With solid wood, the side panels can expand and contract about  $\frac{1}{4}$ ", depending upon species and grain orientation. With this slab-sided construction, drawers run on drawer rails, and the rails are cross-grain to the solid wood sides.

On period pieces, the drawer rails were sometimes simply nailed to the case sides with the thought that the nails would give enough to prevent splitting. That usually worked, although the notion of nailing a structural part into a fine piece of furniture is not an attractive option for me.

Also, as Storb noted, nails of the 18th century were forged and quite soft, whereas modern nails, even the reproductions from Tremont, are much harder and thus less easily bent. Seen when effecting repairs, often an old nail will be bent much like the letter "Z" due to cross-grain wood movement. Modern nails do not bend easily and can cause splitting.

A better method is to let a stopped dado carry the weight of the drawer on the rails, and connect the rails in a frame held together with mortise-and-tenon joinery. The trick is to glue in the front and rear drawer blades, glue the front mortise-and-tenon joints that connect the drawer blade to the front of the drawer rails, but not glue the rear mortise-and-tenon joints or the rail into the stopped dado.

Instead, on the rear of the drawer rails, cut the tenon's shoulder about  $\frac{3}{8}$ " short

so that, when assembled, there is a gap at the shoulder. Wax the unglued tenon to ensure it does not stick. Then, when the seasons change, the carcass sides will not split.

### Applied Mouldings on a Solid Case

Many pieces of furniture are adorned with mouldings, both simple and complex. When these are applied to the front of a piece, glue is all that is needed. The moulding will cause no problems because the grain is running the same direction. But when you turn the corner and apply moulding to the side of a solid-wood case, the moulding and the case side are cross-grain to each other.

The historic way that furniture makers installed the return mouldings was to glue the front several inches at the miter, then nail it to the case the rest of the way back. This works, but it is not a very elegant solution.

A second way was to cut a dovetail socket on the backside of the moulding, then install a key on the side of the case.

Apply glue to the key in several places and carefully cut the dovetail key into pieces perhaps 2"-3" long, then remove every other one. Slide on the moulding, gluing it only at the front. This can work well, especially for larger mouldings, but on smaller mouldings there may be scant material in the moulding profile to permit the cutting of the socket. And if the piece is inadvertently lifted by the seemingly solid moulding, breakage is likely.

A third method of dealing with the return mouldings on the side of a piece was to make the return moulding of end-grain material, thus avoiding any cross-



**End grain return.** In this solid wood dining room piece, the end-grain method for creating the return mouldings was used. This piece was subject to flood damage, so the delicate end-grain mouldings deteriorated.



**Elegant solution.** A plinth built like a drawer web frame with an unglued, short-shouldered tenon at the rear accommodates the side movement.

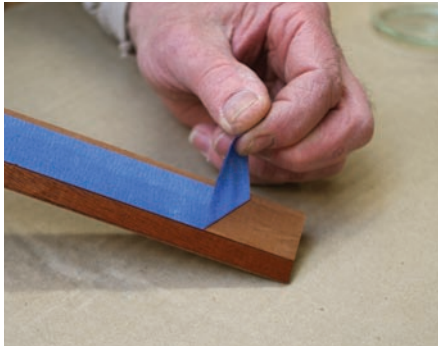

**Stick here, not there.** Shellac the portion of the moulding that will overhang the solid wood case so you don't accidentally glue the moulding to the solid wood case side.

grain situation. This is a not-uncommon method seen in New York pieces. While it does avoid the cross-grain conundrum, the end cuts lack strength and are subject to breakage and deterioration, lacking, as they do, any long-grain structure.

Far less common, a fourth way to attach mouldings is similar to the drawer web-frame method. Build a mortise-and-tenon plinth base or top, thinner than the height of the moulding, and attach that to the case in a manner similar to the drawer frame.

Cut the front mortise and tenon in the traditional manner, but make the shoulder about  $\frac{3}{8}$ " short on the rear of the side rails. Glue on the front rail of the plinth, glue the front mortise-and-tenon joints,

and glue the rear of the plinth to the case – but do not glue the rear mortise-and-tenon joints and do not glue the side rails to the case.

Glue the moulding to the front of the case, and for the mitered returns, glue them to the side of the front plinth and to the side rail, but not to the end grain of the rear rail. Glue the moulding to the plinth only, and not to the case.

To protect against accidental glue creep onto the case, mark out the thickness of the plinth on the back of the moulding then carefully apply a coat of shellac to the portion of the moulding that will not be glued. Work carefully to prevent glue squeeze-out onto the case.

### Glue Blocks & Bracket Feet

Bracket feet are attractive but generally not structural. Often the weight of a carcass is carried on hidden corner blocks, not on the feet themselves. This is because the bracket feet sit largely beyond the plane of the carcass due to their shape and the typical presence of a base moulding applied to the case.

The usual corner block is a 1" x 1" piece of solid wood about  $\frac{1}{8}$ " longer than the total height of the foot, glued in long grain to the inside corner of each foot. One sometimes sees a split bracket foot because of this cross-grain construction.

To avoid this potential problem, make up a piece of plywood, so to speak. Make



**Classic problem.** Here is a classically split flat-bracket foot below a customary base moulding. Its inner corner is reinforced with a cross-grain glue block.

a group of  $\frac{3}{4}$ " thick, 1" x 1" squares, and glue them into the inside corner of the feet, one at a time, alternating the grain direction for each layer, as shown in the opening photo.

The long grain will glue well to the inside of the feet, and the corner block will swell and shrink with the bracket feet as the seasons change. No strength will be sacrificed. Use rubbed, hot hide glue for this procedure and you will not need to mess with a million small clamps. As the glue dries it will tighten up the corner-block stack and you will have a strong and worry-free set of structural feet.

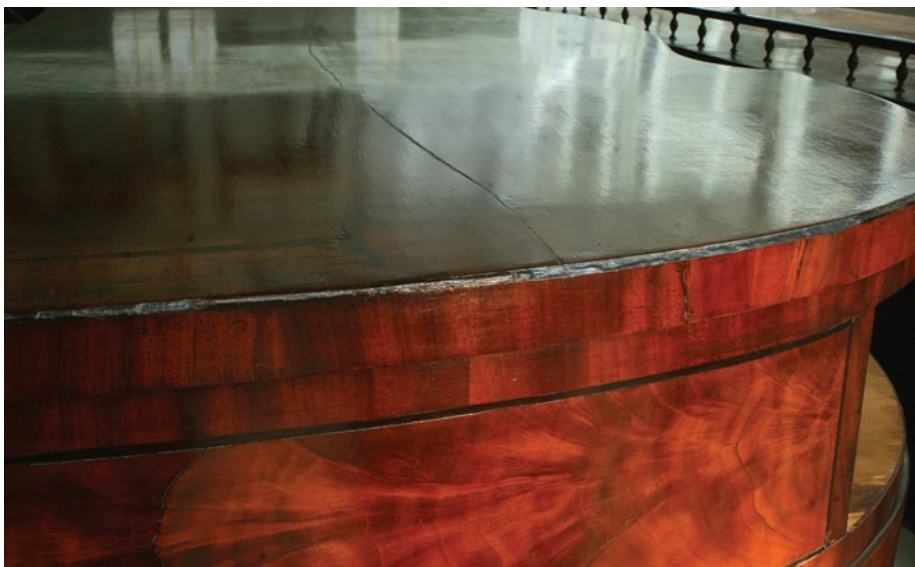

**Immovable object.** This solid mahogany sideboard top is badly split. The top itself is only about  $\frac{1}{4}$ " thick, but it is set on an inflexible substrate: a rail-and-stile structure. The top moved but the substrate did not, so it split.



**Flexible connection.** This mock-up shows how a metal fastener can be installed with an oversized hole to avoid cross-grain splits.



## Attach the Top

If you build a slab-sided carcass and add a solid wood top, there are no cross-grain issues. You can simply glue or screw the top to the sub-top of the case. But for attaching a solid wood top to a plywood

or frame-and-panel case, the top will move winter to summer, but the case sides will not.

The usual method is to drill for tight-fitting screws in the front to set the overhang, then to cut slots for the rear screws,

with the notion that as the top moves seasonally, the slotted holes in the rear will accommodate the movement without splitting the top. This works well, but cutting the slots is fussy work.

An easier method is to drill the rear holes to a proper but generous size for the shank of the screw, then to counterbore from the backside (the top of the sub-top) to provide relief to permit wood movement. Note that at a 20" width, plain-sawn mahogany moves only  $\frac{3}{16}$ " with a 6 percent EMC change, and with cherry and walnut, movement is about  $\frac{5}{16}$ ", so not a lot of room is needed for this simple method to be successful.

### Chronic back problem.

Common in the period, a rather thin, solid wood back was simply nailed on. Splitting is also common.



## Solid Wood Backs

Certainly it is "period correct" to simply nail on a solid wood back of wide, thin planks and be done with your work. But splitting is pretty common when this method is used. Instead, use narrower boards and shiplap them, attaching each board only in the middle to force the wood movement equally on both edges. Or, if more formality is needed (or more strength), use frame-and-panel construction; that will add rigidity to your work.

With some thought and careful planning, even with the extreme moisture content issues caused by modern heating and cooling systems, one can design solutions to avoid improper cross-grain constructions. **PWM**

*Alan is a furniture maker and woodworking teacher, and a partner in the Philadelphia Furniture Workshop.*

*Contact him through the school at [philadelphiafurnitureworkshop.com](http://philadelphiafurnitureworkshop.com).*



**Shiplap solution.** Shiplapped boards, attached only in the middle of each, will avoid the splitting issues inherent in the use of wide planks.

## Go Online FOR MORE ...

You'll find links to all these online extras at:

► [popularwoodworking.com/dec10](http://popularwoodworking.com/dec10)

**WEB SITE:** Visit Alan Turner's web site to see his work and learn about his school.

**ARTICLE:** "Massachusetts Block Front Chest."

**WEB SITE:** Discover the Society of American Period Furniture Makers (SAPFM).

**VISIT:** Philadelphia Museum of Art.

**IN OUR STORE:** "Illustrated Guide to Building Period Furniture" by Glen D. Huey.

All of our products are available online at:

► [WoodworkersBookShop.com](http://WoodworkersBookShop.com)

# English Layout Square

BY CHRISTOPHER SCHWARZ

This useful tool is easy to make, easy on the eyes and awesome to use.

**W**ooden layout tools usually are superior to metal ones in my opinion. They are light-weight, inexpensive and as accurate as woodworking requires. Period.

A 36"-long wooden straightedge can easily be trued to be as accurate as a metal machinist's straightedge, which can cost as much as a good handplane. And you don't have to treat the wooden straightedge like a holy relic. If the straightedge is dropped or run through a wood chipper, you can make another in short order.

In May, I destroyed one of our shop's large wooden squares that we use for marking out the joints for large carcasses. I was about to build a replacement square when I received Patrick Leach's monthly tool newsletter.

Leach's electronic list of tools for sale has always been more dangerous for me than opening an e-mail virus. (Sign up for his free newsletter at [supertool.com](http://supertool.com) – if you dare.) Leach has good taste in vintage tools and manages to find fine stuff, month after month.

In a recent newsletter he listed a gorgeous English layout square in mahogany that I couldn't afford. So I did the next-best thing – I built one (actually two) using photographs and details from Leach.

My square looks like the original, but I changed the joinery to suit me. I joined the center brace with a mitered half-lap instead of a mortise and tenon. And instead of mahogany, I used curly white maple I salvaged from a 19th-century dresser that was headed for the dumpster.



*All this useful beauty.* Tool pusher Patrick Leach found the original of this square in England. I built this reproduction, which is an excellent tool for layout chores.

## Square & Fair

Here's how the square works: The two long legs are joined with a bridle joint. Then you cut the decorative details on the long legs and glue the two pieces together. The center brace is the most work. You cut all the frilly stuff first. Then you cut the lap joints on the brace and trace their shape on the assembled legs. Finally, you cut the lap joints in the long legs, glue in the brace then square the whole assembly.

Begin with the bridle joint. The parts of this square are all 1/2" thick, and you want the tenon on one leg to be one-third the thickness of your stock, which means it should be a little less than 3/16" thick. Cut

the tenon on the end of one leg. Then cut the mating bridle joint on the other.

Now rip away the excess width on each leg right up to the ogee detail. Saw out the ogee details and fair them with rasps and chisels. Glue the legs together and then cut the ogee details on the ends.

## Half-laps Get You Home

Now cut all the details on the center brace and fair everything up. Position the assembled legs on top of the brace exactly where you want them to go and trace the shoulder of your half-lap joints onto the brace with a knife. Saw out the 1/4"-thick half-laps then place the center brace back in position on the legs.

Now trace the shape of the brace on the assembled legs and cut the mating lap joints on the legs. Fit everything so it is nice and tight, then glue the center brace in place.

*"Ya, it's short, but only on one end."*

— Dan Barrett  
planemaker



## Time for the Truth

When the glue dries, trim off any excess wood around the joints and get ready to true the square. I do this on a sheet of poster board. Place one leg of the square on the edge of the poster board and trace along the edge of the other leg onto the poster board. Flip the square 90°, align it with the edge of the poster board and compare the pencil line to the leg. If the line and the leg are parallel, the square is square. If the line doesn't match the leg, you need to plane the exterior of one leg (or both) until the square is indeed square.

Then break all the sharp edges of the tool and apply a few coats of varnish.

After I finished this square, I showed it to Leach, who sold the original to a customer. He said that the antique square was all but destroyed by the post office when he was shipping it to the buyer, so this fine tool could have met a bitter end.

But thanks to these plans (and the SketchUp drawing of this square we've

made available), you can ensure that this attractive and useful design will endure, despite the mail system's best efforts.

PWM

*Christopher is the editor of this magazine and the author of "The Workbench Design Book" and "Handplane Essentials."*



**Clamp like this.** Two bar clamps and an F-style clamp are the best way to clamp the bridle joint. The scrap block helps to distribute the clamping pressure.

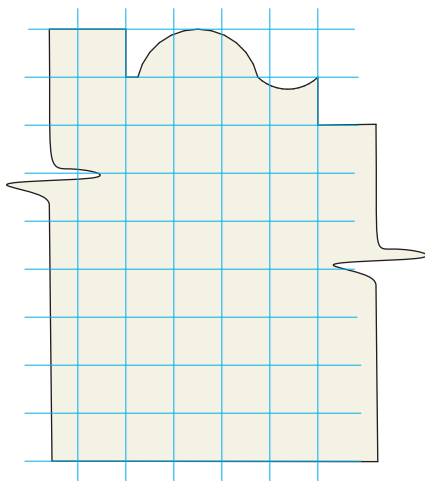

1 grid square = 1/4"

OGEE DETAIL

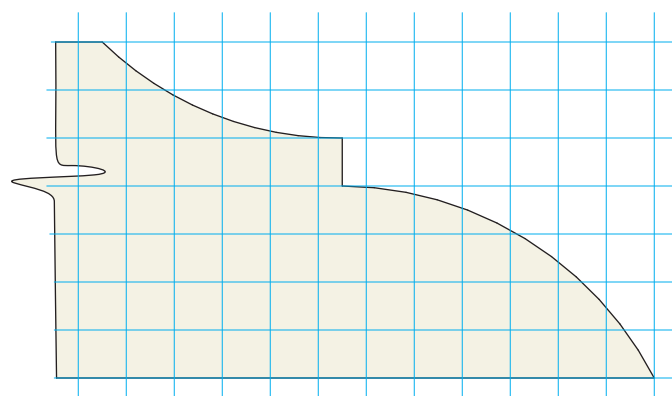

1 grid square = 1/4"

LEG DETAIL

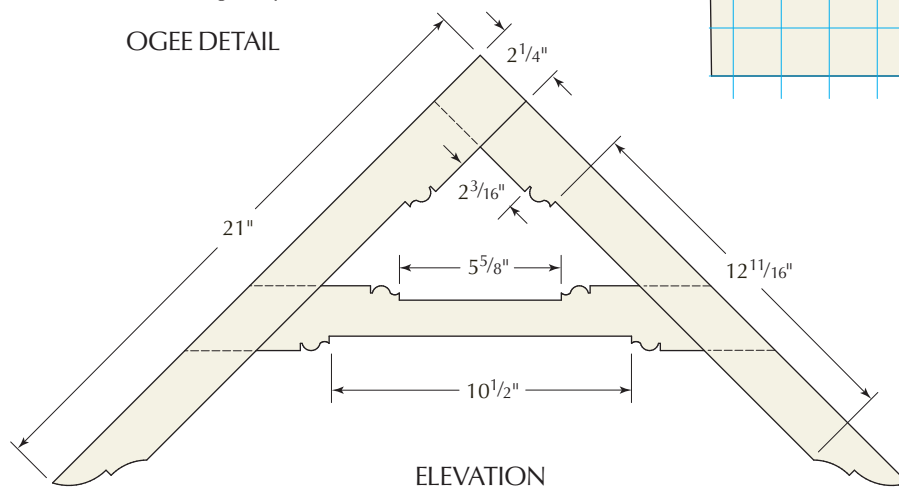

ELEVATION

## English Layout Square

NO.	ITEM	DIMENSIONS (INCHES)			COMMENTS
		T	W	L	
2	Long legs	1/2	2 1/4	21	
1	Center brace	1/2	2 1/4	21	Cut to fit

## Go Online FOR MORE ...

You'll find links to all these online extras at:

► [popularwoodworking.com/dec10](http://popularwoodworking.com/dec10)

**WEB SITE:** Download a free SketchUp drawing of this square.

**BLOG:** See the original square on Chris's blog.

**WEB SITE:** Visit Patrick Leach's amazing Stanley reference site.

**TO BUY:** Plans for André Roubo's try square, a beautiful companion for this tool.

**IN OUR STORE:** "Hand Tool Essentials."

All of our products are available online at:

► [WoodworkersBookShop.com](http://WoodworkersBookShop.com)

# Simple Patterns in Veneer

BY MARC ADAMS

Part 3: Make a 4-way match panel in veneer using mirrors, a knife and a straightedge.

Veneer can be used to embellish any project. For furniture making, veneer offers three advantages: Panels can be made to any size or shape, exotic woods can be incorporated into your work, and veneer offers great design potentials. If a specific style of furniture, such as Shaker or Arts & Crafts, gives a piece of furniture a voice, then adding veneer can give that same piece of furniture a story to tell. Veneer can create strong visual elements with smooth surfaces that can make any furniture piece a showcase. The bonus to working with veneer is it's fun and easy to do.

Veneer panels can be cut to look just like boards glued up edge to edge or matched in ways to create mirror images that reflect the figure in the wood. What might seem to be more advanced veneering techniques include arranging pieces of veneer to create geometric arrangements known as parquetry, or to make recognizable images known as marquetry. Both parquetry and marquetry are relatively simple cutting techniques. Ian Kirby once said that "(F)urniture making with solid wood is like whittling: You chip away at

---

*"Modern plastic paint is at its best, if you don't use it."*

— Professor Panu Kaila  
author of the Finnish book on paint,  
"Kevät toi maalarin"

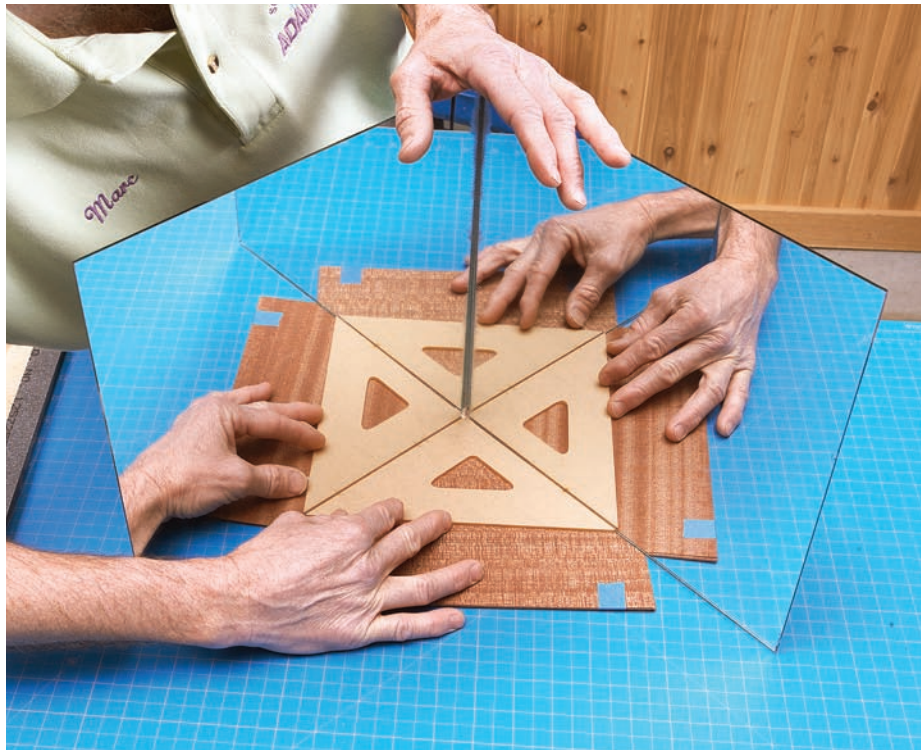

*It's all done with mirrors.* A four-way match veneer panel looks harder to execute than it really is. Here are the steps for cutting, taping and getting it ready for the press.

the tree until you end up with the pieces you need. Working with veneer is just the reverse: You stick the bits together to build up furniture elements of the exact size and shape you want."

Sometimes it's more fun (and educational) to do woodworking projects that are practice pieces. You know, those projects, samples or test cuts that end up as showcase pieces that hang on the wall in your shop. This veneering project will be one of those. This simple wall panel involves the entire process of veneering from edging to pressing.

## The Tools You Need

Veneering can be done with tools and supplies that you probably already have on hand. This is a minimum list of what is needed to cut, arrange, glue and press a typical veneered project.

1. A variety of veneer pieces including at least four pieces of sequential veneer.
2. A self-healing cutting mat.

3. A straightedge that is not longer than 24" and not wider than 2".
4. An X-Acto knife with #11 blades (or a utility knife).
5. Light-tack masking tape and veneer tape (if you can get some).
6. A 45°-45°-90° triangle.
7. A sanding block with #120-grit paper on one side and #220 on the other.
8. A piece of chalk and a pencil.
9. A piece of particleboard or MDF cut to 12" x 12" for the coreboard.
10. Pressing supplies, caul boards and packing tape (or a vacuum bag if you have one) and clamps.
11. Some kind of glue: either white glue or resin glue and a way to spread the glue such as a brush, trowel or foam roller.
12. Two pieces of mirror that are taped (hinged) together.
13. Newspaper.
14. A palm sander along with #120- and #220-grit paper for it, and a rectangular scraper.



## Edge Banding

Edge banding will need to be applied to any exposed edges of veneered panels. Banding can be made from either solid wood or veneer and can be applied before or after the veneer gets pressed on the main face and back. There are advantages and disadvantages to each approach. If you apply the edge banding first, then the face veneers will completely cover the edging; this enables an exact match from one panel to the next. It also helps protect the fragile edge by capping it. The advantage to gluing edge banding on after the main face and back get pressed is that you can cut the core oversized and trim it according to the veneer pattern or panel size desired. If your panel is to have marquetry or parquetry that flows from panel to panel, this will be the edging method that will work best.

Solid wood edges allow for profiling and can stand abuse better than a thinner veneer edge. Wooden edges thicker than  $\frac{3}{4}$ " could telegraph through the veneer if they are applied in the first method. A typical solid wood edge banding is less than  $\frac{3}{8}$ " thick.

## Apply a Veneer Banding

If you are using particleboard as your coreboard, make sure you are using a quality grade material. If the core is brittle or has a lot of edge imperfections you might need to fill then sand the edge(s) to make them

a more solid surface on which to glue. I have chosen to use a piece of  $\frac{3}{4}$ " MDF for my core and the edges will not require filling; they are solid enough to provide a sound gluing surface.

I start by cutting strips of veneer, with the grain, that are just over the thickness of my core by about  $\frac{1}{16}$ " per side or  $\frac{1}{8}$ " overall, so my strips are cut  $\frac{7}{8}$ " wide. I will need four strips that are longer than the coreboard. Once the strips are cut they are ready to be glued on. To help disperse the pressure I use two caul boards that are 1" wide and are longer than the coreboard. I cover these two caul boards with clear packing tape to resist the glue.

Next, I spread white glue on the opposite edges of MDF coreboard, making sure to cover all the fiber. After a minute or so, most of that glue will be absorbed into the fiber, so I might spread a second glue coat if necessary. I then take the veneer strips and apply them to both sides and use a few pieces of blue tape to help secure the veneer in place so that it is centered on the edge. I then place the caul boards (tape side facing the veneer) on both sides and clamp them in place. Watch the veneer to make sure it doesn't slide. If it all looks good, let the glue dry for a few hours.

Once those two sides are dry, remove the caul boards and use a sanding block to sand the veneer flush to the coreboard. If the veneer overhangs the coreboard at the

ends, you can take a knife and trim them close to the final size; however I would use the sanding block to sand to the final size. Make sure you are pushing the sanding block into the coreboard and not out from the coreboard.

Repeat the same gluing procedures for the other side. Once all four sides have been edged and sanded flush, I am ready to design and cut the face veneers.

## Four-way Diamond Match

There are all kinds of four-way matches: butt, diamond, reverse diamond, spiral and so on. The difference among these is simply the way the right angle is cut in relation to the grain/figure of the wood in combination with the way the four pieces are matched together. The best diamond match comes from four pieces of sequenced quarter-cut wood or wood with the straightest figure. Four-way matches can be made by assembling either four square-cut sequential pieces or four triangular sequence pieces. Our diamond match will involve cutting four triangular pieces. Because my panel will need veneer on both sides in order to keep it balanced, I'll make two of these matches – one for each side.

*Marc is the founder of the Marc Adams School of Woodworking (marcadams.com). The next issue will show how to make simple Louis cubes – a tricky looking 3-D effect – and inlay them into this panel.*



**1 The numbers game.** In order to cut a four-way match you will need four sequential pieces of veneer. Verify that they are in sequential order and with a piece of chalk, number each piece in succession.



**2 Stack it to be accurate.** With masking tape, tape the entire bundle together to create a packet of veneer; this will keep each piece from shifting when cutting. I recommend that you stack cut all four pieces.



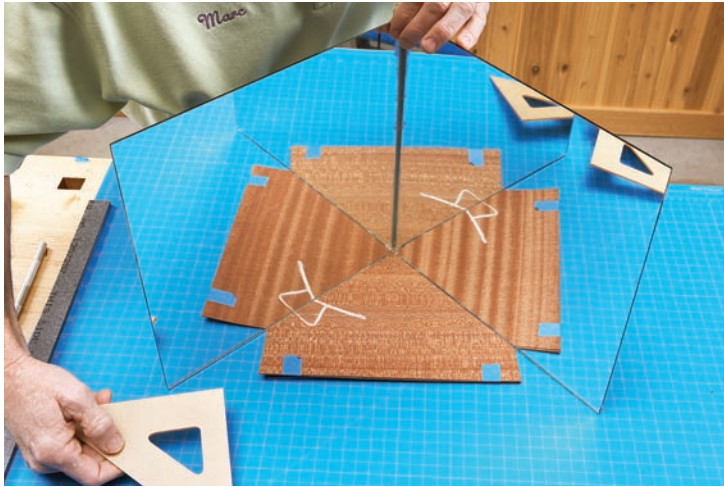

**3 The hall of mirrors.** Place the 45°-45°-90° triangle with the long edge of the triangle (the hypotenuse) running parallel to the grain. Now place the hinged mirror around the 90° side of the triangle. Remove the triangle and verify that the figure looks pleasing. This should reflect what a booked four-way diamond match will look like. Move the triangle and mirror until you find the reflection that looks best.

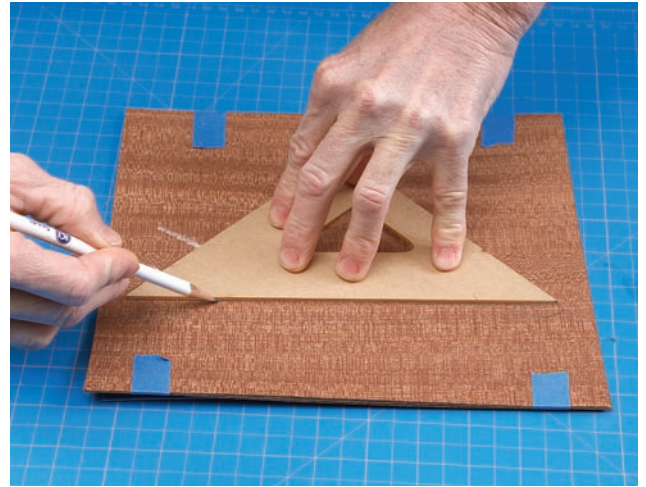

**4 Trace the shape.** Once you choose the look you want, remove the mirror but leave the 45°-45°-90° triangle in place. Take a pencil and mark around the triangle and number each leg to establish side one, two and three. The inside edge or the 90° angle will now be called the "point."

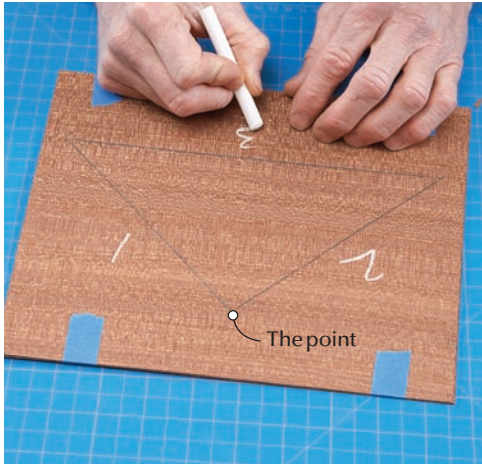

**5 Cut away from the tips.** Next is a hard step to explain, and it has to do with knife cutting in a way that little to no tear-out occurs at the "point" of the veneer. Because the grain on a diamond match causes short lengths of the long grain to be at the center of the match, any tearing of the points will be obvious.

Although there are three cuts to make, the first two are more important. The second cut will determine the direction of the first cut because the second cut needs to have the knife tip start at the point of the veneer packet. This will pull that fragile veneer at the point into the support of the veneer instead of pulling it away. Also, the straightedge should always be on top of the good (or keeper) side of the line. This helps hold the good pieces flat during the cut. Always position the veneer so you make the same cutting motion each time. Never cross your arms to make any cut – if you find this is happening you have not thought out each cut.

**6 Cut by numbers.** I chose to cut line two first, which will allow me to cut beyond the tip of the packet. The straightedge is placed on top of the packet, just on top of the pencil line. Hold the knife as straight up as possible. It will take several passes to cut through all four pieces. Don't try to make heavy cuts; the knife might flex or resist, which could produce a bad cut. After completing the cut, sandwich the veneer packet between two pieces of 3/4" MDF and let a fraction of the cut edge hang out. With a sanding block that has #120-grit sanding paper attached, sand the veneer edges so they all look uniform. Keep the sanding block edge flat on the table; this will create a perfect 90° edge to the veneer. Then use masking tape and tape that edge tightly together. This will help keep the packet together during the next cut.



**7 Start at the tip.** Now cut line one. This cut should allow the tip of the knife to start into the point of the veneer packet. Again make sure the straightedge is placed on top of the packet, just on top of the pencil line. Once the cut is complete, repeat the sanding and taping sequence in the previous step.





**8 An easy finish.** Finish by cutting line three. This cut should be easier than the other two because it will be with the grain. Once the cut is complete, don't worry about the sanding and taping process from the last steps because this edge will end up being cut to size later. You should now have a triangular-shaped packet.



**9 Double-check.** Make sure as you disassemble the packet that you verify that your sequential markings are intact. If not, renumber each leaf. Handle each piece with care – the points are fragile.

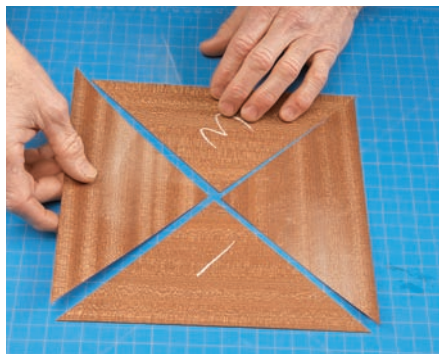
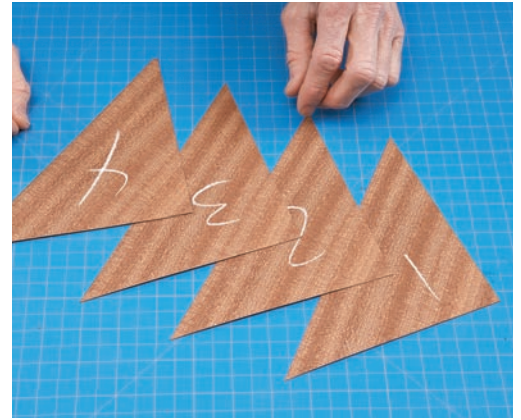

**10 A dramatic flip.** Now comes the arranging. You can put these pieces together in a simple slip-match arrangement, but what you saw in the mirror was a bookmatch. So my order is to take piece one and book it to piece two (one is up, two is down). I also book piece three to piece four (three is up, four is down). I then use masking tape and tape one and two together, keeping the points in a perfect line. I do the same for three and four. This will give you two halves that are masking taped together. Keep in mind that the masking tape will be placed on what will ultimately become the glue face.

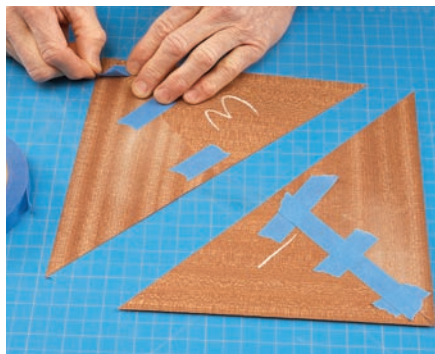

**11 Correct your edge.** To cut each leaf at a perfect 90° angle would only be possible on a Tuesday with a full moon during the summer equinox. So having all four pieces fit perfectly together is rare. So by taking each taped half and placing them between those MDF boards you can sand the edges of both halves to create straight lines. Once the sanding is complete these two halves should be able to be taped together to create a perfect fit. The order should be as follows: 1U + 2D over 3D + 4U. This will ensure that each piece is flipped as it adjoins to the piece it is next to. Use masking tape and tape these two halves together.



**12 Tape the face.** If you are happy with the fit, these four pieces can now be veneer taped together. The masking tape should be on one side only and needs to stay on until the veneer tape is on and dry. I use a sponge that is moist to wet the veneer tape (not too much water, but enough to activate the glue). I then "stitch" across the grain first to hold the veneer pieces tight, then run veneer tape over each joint. Because the veneer tape brings water to the veneer, it might be a good idea to set the veneer under some weight until the water dries (at least 15-30 minutes).

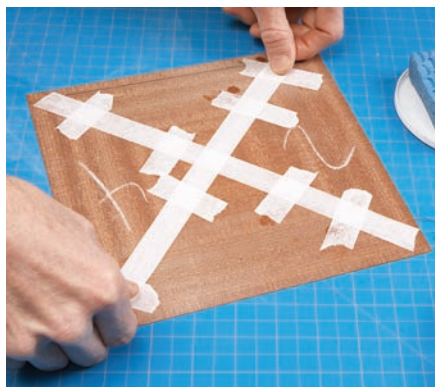

**13 Almost ready for the press.** Once the veneer tape is dry, remove the masking tape from the back side. The panel can now be cut to its final size. Because my coreboard was 12" x 12" I will cut my veneer panel to overhang each side by about 1/8" or so. This panel is now ready for the next step – some inlaid parquetry, which we'll cover in the next issue. **PWM**

### Go Online FOR MORE ...

You'll find links to all these online extras at:

► [popularwoodworking.com/dec10](http://popularwoodworking.com/dec10)

**VIDEO:** Visit the David R. Webb veneer mill with Marc Adams.

**BLOG:** Executive Editor Robert W. Lang takes you on a detailed trip through the Atlantic Veneer slicing operation and the Veneer Tech splicing plant.

**WEB SITE:** Explore veneering classes at the Marc Adams School of Woodworking.

**TO BUY:** Purchase excellent veneers from Certainly Wood.

**IN OUR STORE:** "A Woodworker's Guide to Veneering & Inlay: Techniques, Projects & Expert Advice for Fine Furniture" by Jonathan Benson.

All of our products are available online at:

► [WoodworkersBookShop.com](http://WoodworkersBookShop.com)



# Greene & Greene Frame

BY ROBERT W. LANG

Details shaped by hand and eye define the style.

It's easy to get caught in the trap of design by formula. But if art were simply a matter of ratios, a paint-by-number Mona Lisa would be just as good as the one hanging in the Louvre Museum. The curves and lifts that exemplify the work of Charles and Henry Greene are a good example of this.

I made this frame for a class to show how to lay out and shape typical details. The term "typical," however, doesn't really apply to Greene & Greene; each house and the furniture within share elements, but subtle differences separate them from one another. Within the style are variations.

## First, the Functional Form

In several of the homes designed by the Greenes, items as small as light switches and picture frames were included. Many of the frames have the basic design seen here: The stiles are within the rails, and the thicker rails extend past the stiles.

A mortise-and-tenon joint makes the connection at each corner, and I made the joints first. Because the rails stand proud of the stiles by  $\frac{1}{8}$ ", I did the layout from the back edges to keep these faces flush.

I made the mortises with a  $\frac{1}{4}$ " chisel in the hollow-chisel mortiser and cut the tenon shoulders by hand. I set up a fence on the band saw to cut the tenon cheeks, and adjusted the fit of the joints with my shoulder plane and a float.

With the unshaped parts dry-fit, I used a router with a rabbeting bit to form the  $\frac{1}{2}$ "-deep by  $\frac{3}{8}$ "-wide recess for the art. After routing, I squared the corners with a chisel, then marked the locations for the  $\frac{1}{4}$ " and  $\frac{5}{16}$ " square pegs to fall within each joint.



**Subtle differences.** Elements of a style can't be reduced to simple formulas. To capture the essence of Greene & Greene, trust your eye to make the basic shapes and use hand tools to round the edges.

## Please Ignore the Pattern

The pattern on the next page gives the basic shapes I used, but I would encourage you to try your hand at developing your own design. Begin by making vertical centerlines on the top and bottom rails, then take several pieces of paper, cardboard or thin plywood and practice drawing.

On the bottom rail, the step is approximately  $\frac{3}{4}$ " vertically. Draw a line parallel to the bottom edge, and mark where the edges of the stile meet the rail – this is where the curves begin. The two radii at the end of the rail are roughly quarter circles, but don't

use a compass or a template; sketch them by hand until they look good to you.

Connect the line and edge with an extended "S" shape. Sketch this shape as well, without relying on any instruments. If you don't like your first attempt, try again.

*"Art consists of limitation. The most beautiful part of every picture is the frame."*

— G. K. Chesterton (1874-1936)  
English writer



The shape at the top is similar, but the stepped line angles down about 1/4" toward the outer end. The center portion is a gentle arc, and the two ends aren't vertical; they angle in about 1/8" from bottom to top. When you're happy with the shape, transfer the pattern to the wood.

If you used paper, you can transfer the layout by rubbing the back of the paper with a No. 2 pencil in the general location of the lines. Flip the paper over, tape it to the wood and trace the lines. The graphite on the back of the paper will work like carbon paper.

### Over the Edge

The general shape is only half the battle. The edges are all rounded over, but the radii aren't consistent from edge to edge, and they vary along the edges. Before shaping, mark where the stiles land on the rails.

Start with a radius on the long edges of the stiles. Use a block plane or a rasp rather



**Variable curves.** The radius of the rounded edges varies along the length of the edges. A series of rasps will allow you to go from rough to nearly ready in a short period of time.



**Final slices.** A curved-edge card scraper efficiently removes the marks left by the rasp and removes any high spots along the edges.

than a router. The inside edge has a small radius with the corner barely knocked off, leaving a flat of wood next to the glass. The outer edge has more of a curve, approximately 1/4" at the bottom, tapering smaller to the top.

You can't taper with a router unless you make a jig. You can cut this tapered curve with your block plane in less time than it takes to find the router's wrench. Begin by making a bevel, then keep knocking off the corners until a rounded shape is formed.

A block plane can also be used for the straight edges of the rails. Be careful to stop before the pencil line that's drawn where the face of the stiles meets the edges of the rails.

A rasp will let you handle the more complex edges. The same tactics used with the plane also work here: Make a bevel, then remove the corners until a curve is formed. Remove more material at the ends as seen in the photo, then blend the shapes together.

A card scraper will remove the marks from the rasp. Follow up with some fine sandpaper to blend the flat areas into the curves, and to leave a consistent surface for finishing. I applied a few coats of Danish oil before mounting the glass and artwork. This handwork involves some effort, but the end results are worth it. **PWM**

Bob is executive editor of Popular Woodworking Magazine. Contact him at 513-531-2690 x11327 or robert.lang@fwmedia.com.

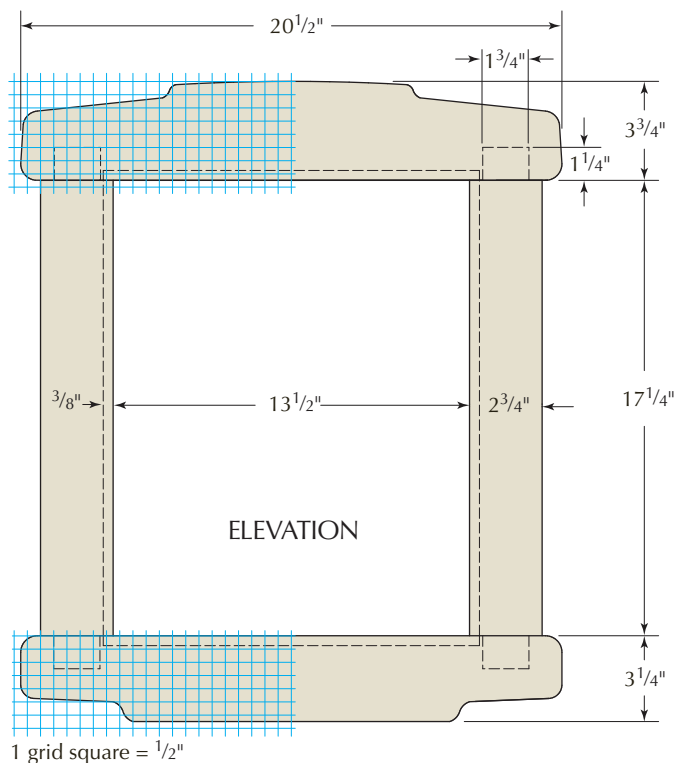

## Greene & Greene Frame

NO.	ITEM	DIMENSIONS (INCHES)			MATERIAL	COMMENTS
		T	W	L		
2	Stiles	3/4	2 3/4	19 3/4	Mahogany	1 1/4" TBE*
1	Top rail	7/8	3 3/4	20 1/2	Mahogany	
1	Bottom rail	7/8	3 1/4	20 1/2	Mahogany	

\* TBE = tenon both ends

### Go Online FOR MORE ...

You'll find links to all these online extras at:

► [popularwoodworking.com/dec10](http://popularwoodworking.com/dec10)

**ARTICLE:** For a review and video of the punches used for plugs, visit our blog.

**IN OUR STORE:** Bob is the author of "Shop Drawings for Greene & Greene Furniture."

**IN OUR STORE:** "Greene & Greene Furniture: Poems of Wood and Light," a new book on the Greene brothers, by David Mathias.

All of our products are available online at:

► [WoodworkersBookShop.com](http://WoodworkersBookShop.com)

# Furniture's Battle Scars

BY MICHAEL DUNBAR

## Part 2: Fictional 'incidents' give a piece a believable back story.

In Part 1 of "Aging Your Projects Gracefully" (November 2010, issue #186), I gave an overview of creating an aged look for new pieces of furniture, and discussed mechanical wear.

The second prevalent type of wear is incidental. "Incidental" means wear that did not result from ordinary use. Incidental wear is what happens to a piece of furniture when it spends time around human beings. Incidental wear might happen while the piece is experiencing ordinary use. However, it is not the result of that use. It is caused by something else. In writing your plausible fiction for a piece you made, ordinary wear is the day-to-day stuff of life. Incidental wear is the events that make life interesting.

Below are a bunch of twists and turns you can include in the plot of the story you are telling as you artificially age a piece of furniture.

### Your Young Vandals

Furniture always endures children. Generation after generation, they are a constant. Children use furniture, but not always in the same way as adults. They abuse furniture. It is part of growing up. Wear records a piece of furniture's encounters with each child it has lived with.

Let's face it: No matter how much we love our kids, they're little vandals. They stand on things. They break things. They bang things. They pick at things. They drag things. All these activities create distinct wear patterns. When I was young every boy carried a pocketknife. When



**Authentic but fake.** A friend of Michael Dunbar's transported this chair for him and the tarp came off in a rainstorm. The result was this wear. When Mike saw the piece he wasn't mad at all. "It looks better now!" he said.

I was not using mine to play "splits" or "mumbletypeg." I was always looking for something to carve or cut my initials into. While I don't remember defacing my mother's furniture, I have seen lots of antique furniture that has suffered at the hands of a bored youngster. Sometimes the vandalism is obvious and carved into a visible surface. However, fearing a parent's wrath, kids often carved in less obvious places. Initials were a popular motif to leave behind.



**Mikey was here.** When Michael Dunbar went to add some "incidental" wear to the seat of this chair, he carved his name in the seat.



## Your Wooden Chew Toys

While families do not generally have as many pets as children, pets can be equally destructive. Dogs chew; cats claw. Dogs are lazy and tend to chew while lying down. Cats invest more effort in creating damage. They can stand up when they sharpen their claws. Keep these thoughts in mind when simulating pet-induced wear.

I once made a large Windsor easy chair just for myself. A short while after I completed it I came into the room to find a puppy with her head resting on a side stretcher while she teathed on the center stretcher. She looked up at me casually as if nothing were wrong, and went on chewing. Her needle-point puppy teeth covered the stretcher with tiny holes. Needless to say, I wasn't happy. However, she grew up to be that one special dog that each of us is awarded in life. She's been gone now more than a decade and those tooth marks now mean the world to me.

Rats and mice are not usually kept as pets, but they do leave their evidence on old furniture. Cupboards and other pieces that contain food attract rodents. The most common damage is a small gnawed hole, often between the lower corner of a door and a stile. The reason they usually enter here is the rodent only had to enlarge a preexisting opening. They will also chew their way into a drawer – front or back, whichever is easier. Once inside a piece of furniture, they get what they are after and seldom do any more damage.

## 'Improvements' to the Piece

During the 18th and 19th centuries all sorts of labor-saving devices were developed. These included sewing birds, yarn swifts, meat grinders and apple peelers. Using these devices required they be secured to a handy surface. Furniture, especially tabletops, was always a likely place. These items relied on a clamp with a lower thumbscrew that was tightened into the bottom of the table leaf. The screw always left marks on the bottom of the leaf, although the clamp itself caused less damage on the top. These marks are usually in a row, a set distance back from the leaf's edge. If the table was in a kitchen or a work area, the marks of several different devices could be clustered in their own separate rows.

Sometimes devices such as a small vise or a pencil sharpener were permanently

*"Truth is so hard to tell, it sometimes needs fiction to make it plausible."*

— Sir Francis Bacon (1561 - 1626)  
English statesman & philosopher

attached to a top. This was more likely to happen to a piece of furniture after it had been relegated to the workshop or barn. In this case, you will generally find screw or nail holes, often in the upper surface. The outline of a backplate may also remain on the tabletop.

## Worn Clean Off

The act of cleaning furniture is often more gentle than normal use, but cleaning will eventually leave its evidence in the form of wear. Like normal use, the wear caused by cleaning is usually predicable. After all, every housekeeper did the same things while caring for furniture.

Wiping a tabletop after preparing or eating a meal is the most frequent activity; a tabletop will be wiped several times a day. While water and a cloth are pretty gentle, they will eventually wear through even the toughest finish. Wood exposed to a wet cleaning cloth and air will fade.

Unless refinished, a century of wiping will eventually remove almost all the finish from a tabletop. Without a finish to protect the wood, housewives would wash the top with harsh, abrasive cleaners such as lye, bleach or pumice to sanitize it and to remove food stains. These products bleached the wood, turning it the color of old bone. Antique collectors call this a "scrubbed top," and a real one is highly prized. Of course scrubbing the top with abrasives also rounds edges and corners. So, you will not find a scrubbed top with crisp edges.

Another furniture-care process had the opposite effect of wiping and clean-



**Worn away.** *This high chair is missing a lot of its finish. One can only imagine that frequent cleaning after a messy child had something to do with it.*

ing. When I began making furniture 38 years ago, my grandmother told me how important it was to “feed the finish.” As most woodworkers know, this is an old wives’ tale. The thought was that finishes dried out and needed to be rejuvenated. The most common method was to wipe the furniture with boiled linseed oil thinned with turpentine. The result was a new layer of finish that made the piece temporarily shiny. Doing this every several years caused the oil to eventually build up. The linseed oil also darkened, leaving a piece that was fed regularly with a dark skin, thick enough to fill shallow details and recessed corners.

A lot of furniture, especially formal pieces with drawers, have brass pulls and lock escutcheons. Brass dulls and on a regular basis over the centuries, good housekeepers polished them. Polishing brasses will wear the metal and soften



**Overfed.** This detail on a mirror has been coated with finish many times by an over-aggressive housekeeper.



**A quart too much.** This chair has been “fed” too much linseed oil over the years, hence its gummy surface finish.



**No key? No problem.** This chest was pried open with a screwdriver at some time during its life – a common form of damage.

its details. The process also wears away the finish around the brass, exposing raw wood.

Any piece of furniture that sits on the floor is regularly assaulted by brooms, mops and vacuum cleaners. These tools bang up the finish and eventually wear away the wood. Add the kicking of shoes to the bumping, banging cleaning instruments and any old piece of furniture will show wear for a height of an inch or two above the floor.

### Breaking & Entering

We all know that wood moves. It swells when it’s humid and it shrinks when it’s dry. As a result, drawers and doors often stick in the summer, requiring they be pried open, usually with a metal tool such as a screwdriver. It is hard to do this with-

out creating some damage. Repeated year after year, the wear caused by prying can become substantial.

### Stains, Smears, Splatters & Burns

Liquids get spilled on furniture. It would be impossible to list all the ways this can happen, but some ways happen more regularly than others. Water rings occur when a wet object is placed on a wooden surface. The ring can be only in the finish, or it can penetrate into the wood. A water stain in the finish is usually white, while a water stain in wood is usually black. A wet glass will leave a small circular white ring in the finish, but the moisture seldom penetrates to the wood. Plants are displayed



**Whack-a-foot.** The leg of this dresser has seen its share of brooms, vacuum cleaners and feet.



**With this ring ...** The top of this dresser has small black rings that are an indication that someone set an ink bottle on it.



on tables and other flat tops for months at a time, a practice that results in a lot of large white and black stains.

Desks and other surfaces where writing is commonly done have ink stains. Remember – when this furniture was new liquid ink came in a small bottle and writing was done by dipping a quill or a steel-pointed stylus. While writing and dipping, it is not hard to knock over the ink bottle.

Humidity in the air will cause rust and stain the wood surrounding iron fasteners, such as nails, screws and hardware. If a piece of painted furniture bumps or rubs against another, it will leave smears and streaks as some of the paint rubs off. As it's moved, furniture bumps into painted woodwork and picks up paint smears that way.

When my son was a toddler he would sometime fling his bottle, spraying milk



**Flick it white.** Any piece that has seen time in the garage or shop is almost certain to have paint splatters on it. Consider this as you plan your project's fictional tale.

droplets. These landed on furniture and dried. Once dry I could not remove them, but was finally able to identify the spray of white spots I had observed on many antique pieces.

For centuries, people have been painting interior woodwork and walls every 20 years or so. Professional painters move the furniture in a room, or cover it with drop cloths, while homeowners are often less cautious. Paint drops, sprays of droplets, and even larger drips are found on antique furniture. People are even less careful when painting in a barn or garage. Any furniture stored there was spattered. Chair seats and small tabletops were used

to hold a paint can, and often have drips and spills.

Lots of antique furniture has burns. Some of these were caused by the flames of candles and lamps. For example, a utilitarian iron candleholder called a hog scraper came equipped with a hook so it could be either hung up or placed on a flat surface. The top slat of a ladderback chair was a common place to hang a hog scraper, as from this location light was cast over the sitter's shoulder. When the candle burned down to a nub, the flame came close to the wood. As a result, you will often find a narrow vertical burn on the rear of a ladderback's top slat.

Clothes used to be ironed with a sad iron. This device was a block of cast iron in the traditional shape we know today. A sad iron was heated by placing it on the stovetop or placing it upright in front of the fireplace. The actual ironing was done on a tabletop. You know without being told that more than one person became distracted and set the iron down on the wood. As a result, lots of antique tabletops bear a distinctive, pointy ended burn.

For centuries smokers have placed lighted cigarettes and cigars on the edge of a tabletop when there was no ashtray handy. The distracted smoker forgets the lighted butt and voilà – a telltale narrow burn on the edge. Some smokers seem to have been pretty prone to this habit and



**Scarred for life.** Someone used this chest as a sawhorse, leaving a permanent mark on the lid and side.



**Busted.** The corners of drawers are vulnerable, and it is common to see their edges chipped out like this.



**On purpose?** The wear on this crest is almost a perfect straight line and looks like it was done on purpose, but it's from the piece's high, narrow shape.

to being distracted, because lots of tables have more than one such burn.

### Damage from Storage

When furniture was not being used (but was still too good to throw out) it was stored in an attic, cellar or an outbuilding, such as a garage or barn. Moving furniture to one of these places often causes scratches and dents where the piece is bumped against other objects such as doorways and stair rails. The same wear from moving furniture happens when antiques are bought or sold. It is so common it is known in the trade as “dealer damage.”

Long-term storage has other results. In the northeast, unheated attics become a freezer in the winter and an oven in the summer. Extremes in temperatures affect furniture adversely. In an attic, wood moves more than it does in a less extreme environment. In time, finishes – both paint and clear – begin to crawl and break up into a pattern like alligator skin. They also flake and loosen. In the antique world this chipped and dried-out look is called an “attic finish.” Many Windsor chairmakers are skilled at simulating an attic finish with milk paint.

The temperature in a cellar remains more stable, but being below ground, basements are humid – especially in the summer. The wood swells. The moisture attacks water-soluble animal glues, and joints loosen. Veneers lift off and inlay falls out. Finishes lose their bond. Sometimes



**Missing tooth.** The edge of this top is missing some of its inlay – a common form of damage seen on tops.

finishes loosen so much that they can be brushed away like dirt.

### Repairs: Good & Bad

Use causes damage, which necessitates repairs. Repairing furniture has been part of every woodworker's daily routine from the beginning of the craft. We are still called upon to do the same work as the old guys. These are the nature of some of the repairs you may want to weave into the narrative as you are aging a piece of furniture.

Old furniture is sometimes converted and adapted to suit the owner's current needs. While many of these changes devalue an antique, you can consider them when creating your fictional history. Conversions usually involve adding

or removing something. Rockers are added to an old chair. A bed is cut down to fit in a room with a lower ceiling.

In conversions and repairs the quality of workmanship varies a lot. Often, the repairman was far less talented than the original maker, and his work will be much rougher. Sometimes a talented craftsman repaired a piece of furniture but added the flavor of his contemporary style. For example, a repair to a Queen Anne piece done around 1800 may have a more Sheraton feel.

The purpose of a repair or a conversion may be to update an old piece. For example, in the 19th century casters were often added to 18th-century table legs. A big part of every chairmaker's business was to repaint old chairs. A Windsor made in





**That fixed it.** Repairs can be good, bad or just plain odd. Adding those to your pieces can be a special challenge.

the 18th century would have been a solid color, usually green. If repainted in 1820, the new finish would likely include stripping and other decorative details, as found on the chairs made in that time.

Nail- and screw-making technology changed from the 18th century to the late 19th century. Repairmen did not hunt up old nails and screws to make repairs. They used what was available. Drawn wire nails and gimlet screws are often found in furniture originally made with wrought and cut nails and blunt-ended, hand-cut screws. A more recent repair might have been made with drywall screws and even square-drive screws.

Repair work often involves replacing missing or broken parts. Once again, workmanship varies a lot. Some repairs are so good they can be detected only by careful examination. Others scream. People sometimes live with furniture that has broken or missing parts, never bothering to fix or replace them. A customer might like such a detail as part of your fictional history. However, antique collectors will accept an old break, but not a new one. Freshly exposed wood will not likely fly.

A piece of furniture with lots of veneer and inlay is unlikely to survive without chips or something missing. Veneer is very vulnerable on corners.

Some furniture includes materials other than wood. The writing surfaces

of Federal secretaries and desks were commonly covered in green baize cloth. The originals are often faded, stained and even moth eaten. Cupboards and bookcases had glass doors made up of many small panes. Usually one or more is cracked. Don't forget these details as you write your story.

### The Stages of Wear

We have seen that except for a bump or a scratch, wear seldom happens all at once. It is cumulative and as a result, goes through stages. Regular rubbing or touching first creates a smooth polish in the finish. These places will be more reflective, and show up as highlights. In time, rubbing or touching will wear through a finish, exposing the wood below. Now, the wood begins to wear. Crisp edges and sharp corners will soften and become round.

The next stage in the process is like the effect of water wearing away rock. Many species (especially pine) have softer early wood and harder late wood. In other words, unlike plastic, many species of wood are not a single consistency. Softer areas will wear away, leaving the harder parts standing proud. Knots are hard and they wear much more slowly than surrounding wood. The result of slow wear on wood is a smooth but textured surface—a surface that tells your fictional history with the voice of the ages.

Wood that is bumped repeatedly (as by



**Wrong nail.** Wire nails, which have a round shank and a round head, were invented in the 19th century and have no place on an early piece such as this—unless they were added to repair a piece.

cleaning instruments) wears differently. This is what happens over a long period of time. At first bumps bruise, crush and bend fibers. Additional bumps cause even more of this and eventually begin to loosen fibers. More bumping will break off these loose fibers, exposing those below. The exposed wood is not smooth, but rough. The rate at which this erosion happens also depends on the species. Very hard woods such as maple hold up better than softer woods.

Good luck creating your fictional histories. Remember, the life of a typical piece of furniture is a lot like ours. While all sorts of things happen to people, seldom does everything happen to one person. Tell a good story, but don't get carried away. Keep it believable. **PWM**

*Michael is the founder of The Windsor Institute ([thewindsorinstitute.com](http://thewindsorinstitute.com)), the country's premier school for teaching the craft of making Windsor chairs.*

### Go Online FOR MORE ...

You'll find links to all these online extras at:

► [popularwoodworking.com/dec10](http://popularwoodworking.com/dec10)

**BLOG:** Read Mike Dunbar's blog.

**WEB SITE:** Visit the web site of The Windsor Institute, where Mike teaches.

**BLOG:** Read about Editor Christopher Schwarz's class at The Windsor Institute.

**IN OUR STORE:** "Chairmaking Simplified."

All of our products are available online at:

► [WoodworkersBookShop.com](http://WoodworkersBookShop.com)

BY BOB FLEXNER

# Staining Wood

A primer on coloring.

A wood stain is a colorant (pigment or dye) and a binder (some sort of finish) with a lot of thinner added so the excess stain is easy to wipe off. This leaves some color in or on the wood.

A stain can also be just dye and thinner with no binder added.

Pigment is ground earth or colored synthetic particles, so it requires a binder to glue it to the wood. Pigment settles to the bottom of the can and has to be stirred into suspension before use.

Dye is a colorant dissolved in a liquid, so dye penetrates along with the liquid and doesn't need a binder. Coffee and tea are examples of weak dyes.

## Purpose of a Stain

There are three good reasons to use a stain:

1. Make a cheaper, less interesting (usually lighter) wood look like a more expensive (usually darker) wood such as walnut, cherry or mahogany.



**Why stain?** One of the principal reasons to stain wood, especially lighter woods such as this birch plywood, is to make them resemble more desirable darker woods, in this case walnut.



**Pigment.** Pigment settles to the bottom of the can and has to be stirred into suspension before use. Because the pigment particles are solid, they require a binder (some type of finish) to glue them to the wood.

2. Match the color of an existing object.

3. Change the color of the wood to create a décor you or someone else has in mind.

You don't need to use a stain unless you want to change the color of the wood. If you do apply a stain, you do it before applying the finish.

## Types of Stain

Common categories of wood stain include the following:

- Oil stain (which thins and cleans up with mineral spirits).
- Water-based stain (which thins and cleans up with water).
- Gel stain (which is thixotropic, like mayonnaise – it's thick in the can, but can be spread and wiped off easily).
- Dye stain (which is a colorant dissolved in a liquid).
- Combination stain and finish (which doesn't color as effectively and is streaky with brush marks if brushed and not wiped off).
- Lacquer stain (which is a very fast-drying stain used by professionals who

spray it and wipe quickly; often applied by two people).

The primary differences in stains are as follows:

■ **Ease of application.** Oil stains are the easiest to apply because you have plenty of time to wipe off the excess. All the other stains dry quickly so you have to work fast or on smaller areas at a time.

■ **Drying time.** Lacquer stains, and dye stains dissolved in solvent (not water), can be coated over within minutes. Water-based stains can be coated over after about an hour. Gel stains, and dyes dissolved in water, require four to six hours before coating over. Oil stains should be allowed overnight drying.

■ **Grain definition.** All stains provide good grain definition if the excess is wiped off, because more colorant is left in the grain. Dye stains produce slightly less definition than pigment stains.

■ **Color control.** Dye stains provide the best control of color – that is, getting the color darker without obscuring the figure of the wood. Dye is see-through; you can apply as many coats as you want and still see the wood's figure. Pigment hides.

CONTINUED ON PAGE 62

PHOTOS BY THE AUTHOR



## Big News From Forrest

# 4 New Blades For Discerning Woodworkers

Forrest sets the standard for excellence with these new top-quality blades:

- **Woodworker II 48-Tooth Blade** for general-purpose applications. Features a 20° face hook, a 25° bevel, and sharp points for clean cross-grain slicing and quiet, smooth cutting.
- **“Signature Line” Chop Master** for quiet, precise cutting and less splintering. Features 90 teeth, a -5° hook to control the feed rate, and re-designed angles with 10” or 12” diameters and 5/8” or 1” center holes.
- **2-Piece & 4-Piece Finger Joint Sets** with reversible, interlocking 8” blades. Ideal for rabbets and grooves. Blades have 24 teeth and standard 5/8” bore. Reversible for 3/16” and 5/16” cuts or 1/4” and 3/8” cuts.
- **Thin Kerf Dados** for clean cutting of 3/16” to 1/4” grooves in thin plywood and man-made materials. Available in two-piece and three-piece sets for table or radial arm saws.



Our blades are U.S.A.-manufactured and have a 30-day, money-back guarantee. Custom sizes available. Order from Forrest dealers or retailers, by going online, or by calling us directly.

**FORREST**  
The First Choice of Serious Woodworkers Since 1946

[www.ForrestBlades.com](http://www.ForrestBlades.com) 1-800-733-7111 (In NJ, call 973-473-5236)

© 2010 Forrest Manufacturing Code PW

For more information, go to [PWFREEINFO.COM](http://PWFREEINFO.COM).

# TURN YOUR VAC INTO A HOT ROD



U.S. Pat. #  
7,282,074  
E.U. Pat. Pend.

Vacuum Not  
Included.



The Dust Deputy's cyclonic action eliminates clogged filters for maximum vacuum performance.

Dust can clog filters almost immediately. Our patented award-winning design retrofits easily to any shop vacuum and removes over 99% of dust.

**Dust Deputy**

Order Online at [oneida-air.com](http://oneida-air.com) Call for your FREE catalog!  
800.732.4065



For more information, go to [PWFREEINFO.COM](http://PWFREEINFO.COM).



## Epilog Laser and PhotoLaser Plus



Systems starting at \$7,995!

**MADE IN USA**

We've combined Epilog Laser's unbeatable engraving quality with CADlink's powerful laser photo processing software, PhotoLaser Plus.

View an online demonstration of PhotoLaser Plus and see how it will provide stunning photo engraving results at [www.epiloglaser.com/popwood.htm](http://www.epiloglaser.com/popwood.htm).

[sales@epiloglaser.com](mailto:sales@epiloglaser.com) • 888-437-4564

For more information, go to [PWFREEINFO.COM](http://PWFREEINFO.COM).

CONTINUED FROM PAGE 60

### Conditioning the Wood

The purpose of “conditioning” or “wash-coating” wood before applying a stain is to reduce blotching, which is uneven coloring caused by varying densities in the wood. A wood conditioner or washcoat is any finish thinned to about 10 percent solids so it doesn’t fully “seal” the wood. Some of the stain can still penetrate.

The woods that blotch are softwoods such as pine and tight-grained hardwoods such as maple, birch and cherry. There’s no point in applying a wood conditioner/washcoat to medium- or coarse-grain woods such as walnut, mahogany or oak.

Varnish wood conditioners (the common ones found in home centers and paint stores) are varnish thinned with about two parts mineral spirits (paint thinner). You



**Washcoat.** A washcoat, which is any finish thinned to about 10 percent solids, can be used to reduce blotching, but it also reduces the intensity of the stain’s color. On this sample, I applied a varnish washcoat (wood conditioner) to the left side of the panel and let it dry overnight. Then I applied a stain to the entire panel.



**Wiping.** The basic rule for applying all stains is to apply a wet coat and wipe off the excess before it dries. It’s much faster to apply stain with a cloth than it is to brush on the stain.



**Types of stain.** There are six common types of stain. From left to right are examples of oil stain, water-based stain, gel stain, two types of dye stain – liquid (both concentrated and thinned) and powder, combination stain and varnish, and lacquer stain.

can make your own. The key to getting the wood conditioner to work is to let it dry fully before applying the stain – at least six hours, better overnight.

### Stain Application

The basic rule for applying all stains is to apply a wet coat and wipe off the excess before the stain dries. Unless the wood is naturally blotch-prone or you haven’t sanded the wood well enough to remove all gouges and scratches, you will always get an even coloring.

You may need to divide your project into smaller sections or have a second person wipe as you apply to get good results using one of the faster-drying stains. It’s much faster to wipe the stain onto the wood with a cloth, wearing gloves of course, than to brush it. (I can’t remember ever brushing a stain.)

### Application Problems

Common problems and ways to avoid them:

- The stain dries in spots before you get it all wiped off, leaving an uneven coloring. If you are quick enough, you can wipe with more stain on smaller sections at a time to re-liquify the stain so you can then wipe it off evenly. Otherwise, strip with lacquer thinner, acetone or paint stripper and restain smaller parts at a time or get a second person to help.

- The color of the stain doesn’t match what you expected from the name on the label. Names are simply manufacturers’ interpretations. There are no industry standards.

- The color of the stain on your project isn’t the same as on the color sample in the

store. Woods color differently. Always try the stain on scrap from your project and make adjustments (add pigment or thinner) as necessary to get what you want.

- Glue from squeeze-out or fingerprints seals the wood, which prevents stain penetration. Sand or scrape off the glue through the stain and restain that area, or leave the splotch and disguise it by painting in the correct coloring after you have applied a coat of finish.

Stain problems such as blotching and getting the color wrong can be extremely difficult to fix. You can usually remove some of the color by wiping with the thinner for the stain. If the stain contains a binder (it isn’t simply dye), you can use a paint stripper. But nothing short of sanding will remove all the color.

The difficulty correcting stain problems is surely one of the reasons so many woodworkers avoid staining altogether.

PWM

Bob is author of the new book “Flexner on Finishing,” available from Popular Woodworking Books.

### Go Online FOR MORE ...

You’ll find links to all these online extras at:

► [popularwoodworking.com/dec10](http://popularwoodworking.com/dec10)

**ARTICLE:** Learn how to properly sand to prepare your wood for stain.

**TO BUY:** Bob’s new book, “Flexner on Finishing,” includes 12 years’ worth of updated finishing columns.

**WEB SITE:** Read more of our finishing articles.

All of our products are available online at:

► [WoodworkersBookShop.com](http://WoodworkersBookShop.com)



# EVERY 2010 ISSUE of *Popular Woodworking Magazine*



**SEARCHABLE • PRINTABLE • PORTABLE**

**ALL 2010 ISSUES On One Disc.**

**2010 Annual**  
Issues 181 through 187  
popularwoodworking.com

**Searchable • Printable • Portable**

Packed with all seven issues of *Popular Woodworking Magazine* from 2010, this CD has more than 400 pages of pure woodworking information that you can search by keyword, take with you on your laptop or print to use in your shop. (It's in PDF format, so the files work on almost any computer).

Get quick, easy and convenient access to more than 25 furniture and shop projects, 10 expert finishing articles, techniques for hand and power tools, honest tool reviews, no-nonsense jigs and much more!

Order the "2010 *Popular Woodworking Magazine Annual*" CD Now at [WoodworkersBookShop.com](http://WoodworkersBookShop.com) or call 1-800-258-0929.

\$19.96 (US) \$22.96 (CAN) • DVD  
ISBN 978-1-4403-1299-1 • #W0671

## Start Making Puzzle Boxes Today!

Jeff Vollmer, the "King of Puzzle Boxes," shares his secrets for making these fun and fanciful band-sawn boxes, with more than two hours of step-by-step video instruction!

- Learn how to perfectly set up your band saw, and which blades to use
- Discover how to select wood that will really make your projects "pop"
- See up close how to make the right cuts, step by step, including multiple complex cuts
- Learn special techniques for sanding, clamping and finishing your puzzle boxes



Order the "Puzzle Box Magic" DVD now at [WoodworkersBookShop.com](http://WoodworkersBookShop.com) or call 1-800-258-0929.



**Puzzle Box Magic**  
with Jeff Vollmer

Copyright ©2010  
F+W Media, Inc.  
X3154



\$19.99 US ■ \$22.99 CDN ■ DVD  
ISBN 978-1-4403-1162-8 #X3154

BY CHRISTOPHER SCHWARZ

## Moxon's Ingenious Bench Vise

17th-century design saves  
your 21st-century back.

If you cut dovetails by hand, then I'm sure you're aware of the other part of your anatomy that is involved: your back.

Bending over rows of tails and pins all day is murder when you try to stand up straight. Several people have come up with solutions, including a cute mini-bench that you park on your full-size bench to raise your work. Other woodworkers have built benches with higher benchtops that are designed just for hand-joinery.

Of course, like most things in woodworking, someone had already come up with the solution several centuries ago.

### 'Mechanick Exercises'

Joseph Moxon wrote the first English-language book on woodworking titled "The Mechanick Exercises" in 1678. In it he showed many of the tools used by the contemporary joiner, from the workbench down to the dividers.

In one part of his book he discusses the "double-screw" vise. It looks like a twin-screw vise with two jaws that has been affixed to the front of a workbench.

But the text discusses how the vise can also be clamped down to the top of the workbench.

When that piece of information sunk in, I got excited and built a prototype. After a few revisions, here is what I came up with.



**Back to the future.** This vise might not have originally been intended for cutting dovetails, but boy is it great for it. It raises your work, then stows away when you don't need it.

This vise solves a lot of problems that we joiners have. It allows you to hold stock of almost any size (mine holds up to 24<sup>1</sup>/<sub>8</sub>"-wide material) with an incredible grip. More so, it raises your work above your benchtop surface. The vise as shown is 6" high, so the top edge of the vise is 39" from the floor. The board I've clamped in the vise is 44" off the floor and is as stable as something clamped between two boulders. What does that mean?

No more stooping to saw dovetails, tenons or other joinery.

And because the vise is portable, that means I can:

1. Put the vise wherever I want on the bench – the end, the back edge, wherever.

2. Remove it when I don't need it and hang it on the wall – most woodworkers don't need a twin-screw vise every day.

3. Leave it unclamped on the benchtop, and use it like a giant handscrew clamp (Peter Follansbee at Plimoth Plantation hipped me to this function).

The vise is quite easy to build – I used

some scraps. The only other key piece of shop equipment is an 1<sup>1</sup>/<sub>2</sub>" wooden thread box and tap, which is available at many suppliers for less than \$50.

### Tap the Jaws

The first step is to cut the 1<sup>1</sup>/<sub>2</sub>"-diameter clearance holes in the front jaw. Position the holes so you'll have 24<sup>1</sup>/<sub>8</sub>" between them. Then center the front jaw on the rear jaw



**Tap then tap.** Place the front jaw on the rear jaw. Drop your Forstner in the hole. Tap it with a hammer. Then drill the hole in the rear jaw and tap that.

CONTINUED ON PAGE 66





Inlay Tool Set

www.lie-nielsen.com  
1-800-327-2520  
Warren, Maine USA

For more information, go to PWFREEINFO.COM.



**Marc Adams School of Woodworking** is committed to fine woodworking excellence through hands-on learning experiences with the best woodworkers of modern time.

Check out our new interactive brochure online at [www.marcadams.com](http://www.marcadams.com)  
317-535-4013

- Over 130 workshops that last from one day to two weeks
- More than 60 internationally recognized instructors
- Classes are hands-on in a facility that is unrivaled



For more information, go to PWFREEINFO.COM.

SINCE 1972  
**Hartville Tool**  
OHIO'S LARGEST TOOL STORE!

**100 PC. For A Limited Time**  
**Rare Earth Magnet Value Pack**  
Item # K10369

**SAVE 60% Only!**  
**\$15.98**  
Reg \$39.99  
Offer Valid for 90 days

**Special Value Pack Includes:**  
45 ea. 1/4" Magnet # 10369  
30 ea. 3/8" Magnet #10370  
25 ea. 1/2" Magnet # 10371

**FREE! SHIPPING**  
On Orders Over \$99  
(Lower 48 States)

**FREE Catalog!**  
[hartvilletool.com](http://hartvilletool.com)  
800-345-2396

For more information, go to PWFREEINFO.COM.

**FESTOOL**

**BOB MARINO**  
SERVICE AS IT SHOULD BE



*"You are buying world class tools and I provide the same world class service to back them up. If you have a question or issue, I will offer a solution as quickly as I can so you can get back to work!"*

**CT 26 / CT 36 Dust Extractors**



The most complete dust removal system just got better!

- HEPA Filtration is standard
- Self-cleaning filter bags
- Next generation high-performance motor
- Integrated hose garage
- Increased capacity

Order Festool's new CT 26 and CT 36 HEPA equipped Dust extractors today!



**FREE SHIPPING ON ALL FESTOOL ORDERS!**  
No sales tax collected outside of NJ and OH.

3 3 7 8 6 6 5  
**CALL 1.866.FESTOOL**  
[www.BobMarinosBestTools.com](http://www.BobMarinosBestTools.com)

CONTINUED FROM PAGE 64

and clamp them together. (Note: The front jaw is wider than the rear jaw so that it is easier to line up the rear jaw with the front edge of your benchtop.)

Drop a 1½" Forstner bit into each hole and tap the end with a hammer – this transfers the centerpoint of the hole to the rear jaw.

Unclamp the jaws and drill 1⅜" holes through the rear jaw. Then use your tap to tap the holes in the rear jaw (a little linseed oil or a non-drying vegetable oil makes a good lubricant).

### Turn & Thread the Screws

The vise's screws are made from 2" x 2" walnut. I planed a 25"-long section to an octagon then chucked that in the lathe. I turned the middle 14" down to just a shade less than 1½". Then I crosscut the piece, ending up with two 12½"-long handles.

Clamp a vise screw with the round section facing up and use your threadbox to thread the round section. Test the results in the rear jaw. If the screw squeaks or doesn't turn freely, adjust the cutter in the threadbox so it cuts slightly deeper.

### Add the Rear Brace

The vise will be more stable if you glue a rear brace on the backside of the rear jaw, which will increase the surface area that contacts your bench. Glue and clamp the rear vise in place.

Add some details if you like. I chamfered the front edges of my front jaw and the ends of the vise screws. I applied a couple coats of an oil/varnish blend finish.

## Joseph Moxon's Double-screw Vise

NO.	ITEM	DIMENSIONS (INCHES)			COMMENTS
		T	W	L	
2	Bench screws	2	2	12½	7" of screw is 1½" dia.
1	Front jaw	1¾	6⅛	32⅛	
1	Rear jaw	1¾	6	36⅛	
1	Rear brace	1¾	2	30	

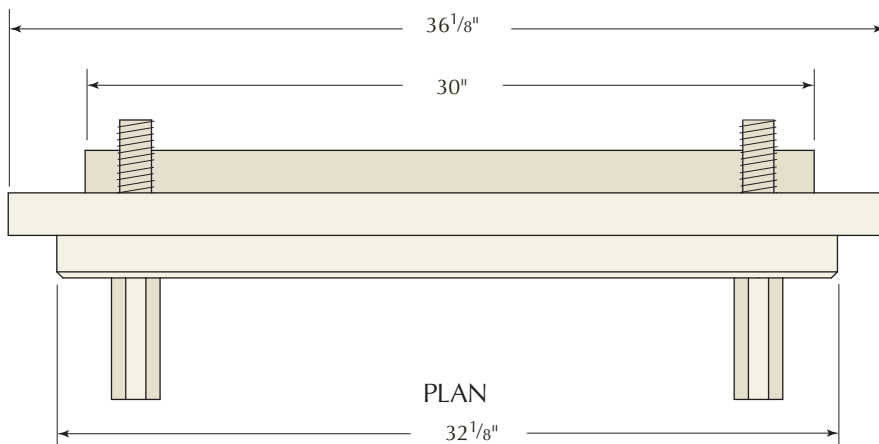

I also glued on a layer of suede to the inside face of the front jaw, which improves the vise's grip even more.

I've been testing the vise for more than three months (and I made versions for co-workers and friends). If you cut dovetails, I think this vise is well worth making. Your back will thank me. **PWM**

*Chris is the author of "The Workbench Design Book" (Popular Woodworking), which explores ancient and ingenious workholding jigs such as this vise.*

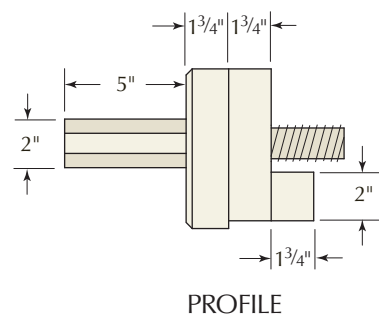

**Two screws from one stick.** The two vise screws are made from one octagonal piece. Turn down the middle. Cut the piece in half. Thread the round sections.



### Go Online FOR MORE ...

You'll find links to all these online extras at:

► [popularwoodworking.com/dec10](http://popularwoodworking.com/dec10)

**VIDEO:** See a video of the author threading and tapping the wooden components.

**ARTICLE:** We have dozens of free plans for jigs on our web site.

**WEB SITE:** Read about how the prototype was developed on our blog.

**TO BUY:** Find links to buy the manual wood-threading kit for this project.

**IN OUR STORE:** New: "The Workbench Design Book."

All of our products are available online at:

► [WoodworkersBookShop.com](http://WoodworkersBookShop.com)



**Walking the talk.**



Hand tools for the serious woodworker

**TOOLS FOR WORKING WOOD**

800.426.4613 32 33rd St. Brooklyn, NY 11232

[www.toolsforworkingwood.com](http://www.toolsforworkingwood.com)

For more information, go to [PWFREEINFO.COM](http://PWFREEINFO.COM).

**WOODCRAFT®**

For A Free Catalog Or To Find Your Local Woodcraft Store,  
Visit [woodcraft.com](http://woodcraft.com) Or Call 800-225-1153.

When woodworking is your passion, quality tools, supplies and expert advice from Woodcraft can help take your woodworking to the next level.

**Over 20,000 Woodworking Products!**

- Hand & Power Tools
- Power Tool Accessories
- Routers & Accessories
- Carving Tools & Chisels
- Workbenches
- Hardwoods & Exotics
- Sanding & Scraping
- Woodburning
- Vises & Clamps
- Files & Rasps
- Project Kits & Supplies
- Clock Supplies
- Planes & Saws
- Woodboring Tools
- Sharpening Supplies
- Finishing Supplies
- Safety Equipment
- Woodturning
- Hardware
- Marking & Measuring
- Cabinetmaking Supplies
- Shop Accessories
- Books & DVDs



10PW12Q

**QUALITY WOODWORKING TOOLS • SUPPLIES • ADVICE®**

For more information, go to [PWFREEINFO.COM](http://PWFREEINFO.COM).

**10 YEARS of Popular Woodworking in One Small Package**

- 35+ designs for bookcases and storage
- 400+ pages of plans, step-by-step instructions and drawings
- Essential technique instruction
- And much more – 5,500+ pages in all!



Order 'Popular Woodworking 2000-2009' now –

visit [WoodworkersBookShop.com](http://WoodworkersBookShop.com) and search '2000-2009' or call 800-258-0929.

ISBN: 978-1-4403-0220-0 #Z6070

**Workbench as Work of Art**

Plate II of André Roubo's 18th-century masterpiece "L'Art du Menuisier" shows an interior view of the shop of the craftsman ("Vue Interieure de la Boutique d'un Menuisier," as it says across the top of the page). The lower half of the plate serves as a design reference for the many Roubo-style workbenches built by *Popular Woodworking Magazine* Editor Christopher Schwarz and staff, and the upper half is chock-full of thought-provoking items displayed on the benches and walls of the circa 1760 French shop.

The detail is tremendous, and there are plenty of woodworking lessons still to be learned as we decipher it. And, it's simply a great-looking engraving. So we've reproduced Plate II as an 18"x24" poster on heavy cream-colored paper with crisp black detail. It's perfect for hanging in your woodworking shop – or build a suitable picture frame and hang it in your study.



Order the "Roubo Plate II" Poster now at [WoodworkersBookShop.com](http://WoodworkersBookShop.com) or call 1-800-258-0929.

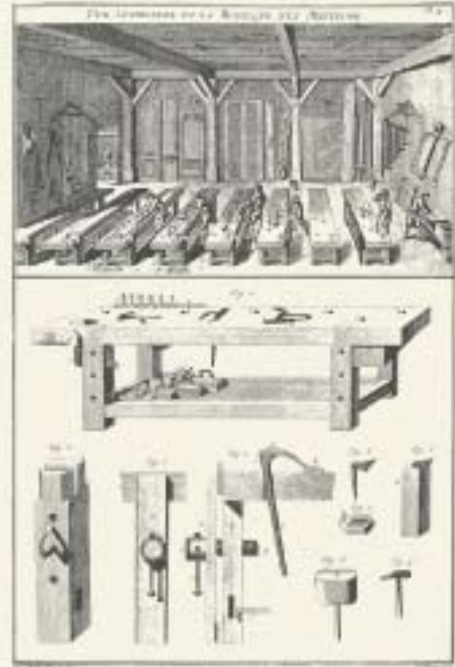

\$19.99 US - \$22.99 CAN #X2815

# WOODWORKER'S MARKETPLACE

Turn logs into lumber.

8 models to choose from

Live life to the MAX.

**Wood-Mizer** 800.553.0182  
SawBoards.com

© Copyright 2010, Wood-Mizer Products, Inc.

dream to the

For more information, go to [PWFREEINFO.COM](http://PWFREEINFO.COM).

**razor TIP**  
Wood-Mizer  
STELLITE® BANDSAW BLADES

**Stellite® tip technology for sawing tough wood**

- Kiln Dried
- Exotic Species
- Resawing

**Wood-Mizer Blades**  
Innovation. Precision. Performance.

1.800.522.5760  
[www.woodmizerblades.com](http://www.woodmizerblades.com)

For more information, go to [PWFREEINFO.COM](http://PWFREEINFO.COM).

**Hands on Instruction for All Skill Levels**

Mario Rodriguez - Alan Turner

For more info on Courses: 215.849.5174

Philadelphia Furniture Workshop

[PhiladelphiaFurnitureWorkshop.com](http://PhiladelphiaFurnitureWorkshop.com)

For more information, go to [PWFREEINFO.COM](http://PWFREEINFO.COM).

Raises the art of pen turning to a new level

The Beall Pen Wizard

**THE BEALL TOOL CO.**

541 Swans Road N.E. Newark Ohio Dept. PW  
1-800-331-4718 [www.bealltool.com](http://www.bealltool.com)

For more information, go to [PWFREEINFO.COM](http://PWFREEINFO.COM).

# BEST DOVETAILS

It's the truth.

Order your Keller Dovetail System now!  
(800) 995-2456

Made in the USA since 1976 • DVD/Video \$8.95 + \$2 p/h

[www.bestdovetails.com](http://www.bestdovetails.com)

For more information, go to [PWFREEINFO.COM](http://PWFREEINFO.COM).

**Mortise Pal™**

PRECISION MORTISING JIG  
[WWW.MORTISEPAL.COM](http://WWW.MORTISEPAL.COM)  
TEL: 619-459-7951  
4580 ALVARADO CANYON RD. STE. E. SAN DIEGO, CA 92120

For more information, go to [PWFREEINFO.COM](http://PWFREEINFO.COM).

**Old English Academy of Fine Woodworking**

Michael J. Gray Master

Hands on Instruction for Groups & Individuals  
Weekend Classes Year Round  
P.O. Box 772 Selmer, TN 38375  
[www.oefce.com](http://www.oefce.com)  
Learn the Fundamentals of Woodworking from an Old World Master

For more information, go to [PWFREEINFO.COM](http://PWFREEINFO.COM).

Lumber • Veneer • Turning Stock

**Your Source for Wood**

WOODWORKERS Source

[www.101woods.com](http://www.101woods.com)  
800.423.2450

VISA M.C. DISCOVER

For more information, go to [PWFREEINFO.COM](http://PWFREEINFO.COM).

**CraftsmanStudio.com**  
Fine Tools - Fair Prices - Fast Shipping

Tools to bring out the best in your work

Authorized Lie-Nielsen and Shapton Dealers

\*Free Shipping over \$75.00

2737 Via Orange Way • Ste 110 • Spring Valley, CA 888-500-9093

For more information, go to [PWFREEINFO.COM](http://PWFREEINFO.COM).

Looking for wood?

VISIT **woodfinder**

It's fast, easy and FREE!

[www.woodfinder.com](http://www.woodfinder.com)  
No computer? Call toll-free 1-877-933-4637

**CRAFTSMAN PLANS**

Authentic Reproduction PLANS BOOKS HARDWARE

Measured & Drawn by Robert W. Lang  
author of "Shop Drawings for Craftsman Furniture"

[www.craftsmanplans.com](http://www.craftsmanplans.com)

FROM THE EDITORS OF **WOODWORKING**

# Weekly Wood News

Learn How. Discover Why. Build Better.

If You Like Popular Woodworking Magazine

Now Get More – **FREE**

- "Weekly Wood News" can be delivered every week right to your e-mail box
- Great woodworking information that just won't wait until the next issue is mailed

See what you've been missing.  
**Sign up today!**

[popularwoodworking.com/newsletters](http://popularwoodworking.com/newsletters)



# WOODWORKER'S MARKETPLACE

## CLASSIFIED

### Books

**WE HAVE A WIDE VARIETY** of woodworking books – from small projects, to home improvement, to enhancing your woodworking skills, and more! To see our full line of books, please visit our web site at [WoodworkersBookShop.com](http://WoodworkersBookShop.com)!

### Finishing Supplies & Equipment

**SPRAY-ON SUEDE** Line boxes easily. Free brochure with sample. DonJer, 13142 Murphy Road, Winnebago, IL 61088; 800-336-6537; [www.donjer.com](http://www.donjer.com).

**BLOXYGEN SAVES LEFTOVER FINISHES** - Just Spray, Seal and Store. [www.bloxygen.com](http://www.bloxygen.com) or (805) 542-9219.

### Hand Tools

**DI LEGNO WOODSHOP SUPPLY** Quality woodworking hand tools at an affordable price. [www.dlws.com](http://www.dlws.com) or 1-877-208-4298.

**WWW.JIMBODETOOLS.COM** The Largest Antique Tool Website on Earth! Fine Antique Woodworking Tools of every kind.

### Power Tools

**FEIN TOOLS** YOU'RE JUST ONE CLICK AWAY from the Fein Tools that you can't do without - MultiMaster Tools - Sanders - Grinder - Vacuums and more, plus all Accessories and Parts. <http://www.waltertool.com> or 800-356-6926.

### Schools/Instruction

**JOHN C. CAMPBELL FOLK SCHOOL**, Brasstown, NC. Courses for all skill levels. Weeklong and weekend classes year-round, taught by nationally known instructors. Friendly, supportive environment. Comfortable, on-campus housing. Delicious meals served three times a day. [www.folkschool.org](http://www.folkschool.org). 800/365-5724.

**THE ACANTHUS WORKSHOP, LLC** Traditional woodworking education with lead instructor, Charles Bender, using conventional hand tools and modern machinery. Call 610-970-5862 or visit [www.acanthus.com](http://www.acanthus.com).

**PRIVATE CLASSES** with woodworking author in the Great Smokey Mountains- All skill levels- [www.GregoryPaolini.com](http://www.GregoryPaolini.com) (828) 627- 3948

### The School at Annapolis Woodworks,

Davidsonville, MD. Turning, Carving, Furniture Making, etc. Weeklong and Weekend classes for all skill levels. [www.annapoliswoodworks.com](http://www.annapoliswoodworks.com) 301-922-0649

### Seat Weaving Supplies

**CHAIR CANE & SPLINT**, Shaker tape, fiber & natural rush. Complete line of basketweaving supplies. Royalwood Ltd., 517-WW Woodville Rd, Mansfield, OH 44907. 800-526-1630. [www.royalwoodltd.com](http://www.royalwoodltd.com).

### Wood & Veneers

**WWW.WALNUTWOODS.NET** Black Walnut Burl Veneer, lumber, turning stock, gunstocks. Buckeye Burl slabs. Call 559-277-8456, Newton Woods, Fresno, CA

*Classified rate is \$6.00 per word, 15-word minimum. Order must be accompanied by payment; ads are non-commissionable. Send to: Popular Woodworking Magazine, 4700 E. Galbraith Rd., Cincinnati, OH 45236 or Don Schroder, [d.schroder@verizon.net](mailto:d.schroder@verizon.net). Phone: 610-821-4425, Fax: 610-821-7884.*

## ADVERTISER'S INDEX

	PAGE #	WEB ADDRESS
Acanthus Workshop	69	<a href="http://acanthus.com">acanthus.com</a>
Apollo Sprayers Int'l.	17	<a href="http://hvlp.com">hvlp.com</a>
Beall Tool Company	68	<a href="http://bealltool.com">bealltool.com</a>
Bloxygen	69	<a href="http://bloxygen.com">bloxygen.com</a>
Bob Marino's Festool Store	65	<a href="http://bobmarinosbesttools.com">bobmarinosbesttools.com</a>
Bosch Tools	4-5	<a href="http://boschtools.com">boschtools.com</a>
Craftsman Plans	68	<a href="http://craftsmanplans.com">craftsmanplans.com</a>
Craftsman Studio	68	<a href="http://craftsmanstudio.com">craftsmanstudio.com</a>
DeWalt	9	<a href="http://dewalt.com">dewalt.com</a>
Di Legno Woodshop Supply	69	<a href="http://dlws.com">dlws.com</a>
DMT	11	<a href="http://dmtsharp.com">dmtsharp.com</a>
DonJer Products	69	<a href="http://donjer.com">donjer.com</a>
Eagle America	17	<a href="http://eagleamerica.com">eagleamerica.com</a>
EBAC Industrial Products	17	<a href="http://ebacusa.com">ebacusa.com</a>
Epilog Laser	61	<a href="http://epiloglaser.com">epiloglaser.com</a>
Forrest Mfg.	61	<a href="http://forrestblades.com">forrestblades.com</a>
Franklin International	7	<a href="http://titebond.com">titebond.com</a>
Freud America	15	<a href="http://freudtools.com">freudtools.com</a>
General International USA	19	<a href="http://general.ca">general.ca</a>
Gorilla Glue	23	<a href="http://gorillaglue.com">gorillaglue.com</a>
Gregory Paolini Designs	69	<a href="http://gregorypaolini.com">gregorypaolini.com</a>
Grizzly Industrial	Cov 2-1	<a href="http://grizzly.com">grizzly.com</a>
Hartville Tool	65	<a href="http://hartvilletool.com">hartvilletool.com</a>
Highland Woodworking	23	<a href="http://highlandwoodworking.com">highlandwoodworking.com</a>
Infinity Tools	23	<a href="http://infinitytools.com">infinitytools.com</a>
Jet Tools	Cov 3	<a href="http://jettools.com">jettools.com</a>
Jim Bode Tools	69	<a href="http://jimbodetools.com">jimbodetools.com</a>
John Campbell Folk School	69	<a href="http://folkschool.org">folkschool.org</a>
Keller & Company	68	<a href="http://kellerdovetail.com">kellerdovetail.com</a>

	PAGE #	WEB ADDRESS
Lee Valley	11	<a href="http://leevalley.com">leevalley.com</a>
Lie-Nielsen Toolworks	65	<a href="http://lie-nielsen.com">lie-nielsen.com</a>
Marc Adams School	65	<a href="http://marcadams.com">marcadams.com</a>
Mortise Pal	68	<a href="http://mortisepal.com">mortisepal.com</a>
Newton Woods	69	<a href="http://walnutwoods.net">walnutwoods.net</a>
Old English	68	<a href="http://www.oefcc.com">www.oefcc.com</a>
Oneida Air Systems	61	<a href="http://oneida-air.com">oneida-air.com</a>
Osborne Wood Products	23	<a href="http://osbornewood.com">osbornewood.com</a>
Philadelphia Furniture Workshop	68	<a href="http://philadelphiafurnitureworkshop.com">philadelphiafurnitureworkshop.com</a>
Popular Woodworking Books	24, 63, 67	<a href="http://popularwoodworking.com">popularwoodworking.com</a>
RadarCarve	17	<a href="http://radarcarve.net">radarcarve.net</a>
Routerbits.com	11	<a href="http://routerbits.com">routerbits.com</a>
Royalwood Ltd.	69	<a href="http://royalwoodltd.com">royalwoodltd.com</a>
School at Annapolis Woodworks	69	<a href="http://annapoliswoodworks.com">annapoliswoodworks.com</a>
Stanley Tools	Cov 4	<a href="http://stanleytools.com">stanleytools.com</a>
Steebar	13	<a href="http://steebar.com">steebar.com</a>
Steel City Tool Works	13	<a href="http://steelcitytoolworks.net">steelcitytoolworks.net</a>
Tools for Working Wood	67	<a href="http://toolsforworkingwood.com">toolsforworkingwood.com</a>
Toymaker Press	11	<a href="http://toymakerpress.com">toymakerpress.com</a>
Wall Lumber	23	<a href="http://walllumber.com">walllumber.com</a>
Walter Tool	69	<a href="http://waltertool.com">waltertool.com</a>
Whitechapel Ltd.	17	<a href="http://whitechapel-ltd.com">whitechapel-ltd.com</a>
Woodcraft	2, 67	<a href="http://woodcraft.com">woodcraft.com</a>
Woodfinder	68	<a href="http://woodfinder.com">woodfinder.com</a>
Woodline USA	21	<a href="http://woodline.com">woodline.com</a>
Wood-Mizer	68	<a href="http://woodmizer.com">woodmizer.com</a>
Woodpeckers	13	<a href="http://woodpeck.com">woodpeck.com</a>
Woodworker's Source	68	<a href="http://woodworkerssource.com">woodworkerssource.com</a>
Woodworker's Supply	23	<a href="http://woodworker.com">woodworker.com</a>

Woodworking's lexicon can be overwhelming for beginners. The following is a list of terms used in this issue that may be unfamiliar to you.

**beading bit (n)**

Often refers to two different router bit profiles. One creates a roundover detail with a quirk at the top and bottom. The second creates a complete half-profile of a bead, such as the moulding used on William & Mary furniture.

**bridle joint (n)**

An open mortise-and-tenon joint where the female part of the joint is a notch and the tenon is full width. Also called a slip joint.

**climb cut (v)**

To shape or cut with a router while moving in the direction that's in the rotation of the router bit. (In normal routing technique, you move against the spin of the router bit.) With this technique, you are less likely to tear out wood fibers as you work. But while working in this manner, the spin can cause the router to lurch forward if you're not careful, and if the router isn't fully supported. Climb cut sparingly.

*"Words are but symbols for the relations of things to one another and to us; nowhere do they touch upon absolute truth."*

— Friedrich Nietzsche  
philosopher & philologist

**cut nail (n)**

An early form of nail that has two long edges that are parallel and two long edges that are wedge-shaped. These fasteners earn their name because they were cut from a stock of flat metal. During the 19th century, cut nails were replaced by wire nails, which are round. Wire nails are cheaper to make and don't require a pilot hole.

**fair (v)**

To alter a shape to make it pleasing to the eye.

**F-style clamp (n)**

A modern woodworking clamp that resembles the letter "F." The top of the "F" is a fixed pad. The middle horizontal line in the "F" is a movable pad that slides up and down the clamp's bar. When the clamp's screw is engaged, the movable pad wedges in place and begins to apply pressure to the workpiece.

**gimlet screw (n)**

A modern style of screw with a pointed tip that helps bore into the wood. The gimlet screw replaced earlier, hand-cut blunt-ended screws.

**guide bushing (n)**

An insert that fits in a router baseplate that is designed to follow a template and guide the router bit, thereby transferring a pattern to a workpiece. Any bit that fits through the bearing hole can be used with a bushing.

**particleboard (n)**

An engineered wood product made from wood chips, shavings, sawdust and a glue binder. It is pressed and extruded to create a dense, stable composite material.

**plinth (n)**

The base or platform on which a primary structure rests, such as a column or a blanket chest.

**rub joint (n)**

A rub joint is made by applying hide glue to two pieces of wood on the edges to be joined, then rubbing them together. Because hide glue tacks quickly, no clamps are necessary to hold the pieces in place. This is a traditional method for panel glue-ups, applying glue blocks, etc.

**sawbench (n)**

A kneecap-level platform that exploits the length of your saw and body to make handsawing efficient and fast. With the workpiece atop the sawbench, one knee holds it down and the other immobilizes it laterally.

**set (n)**

The distance at which the teeth on a saw protrude from left and right of the sawblade. The wider the set, the wider the saw kerf. To a point, a wider set allows the

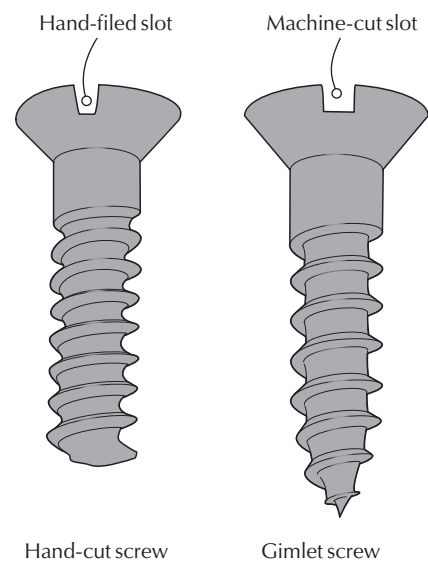

saw to more easily move through a piece of wood without binding. But, a wide set also makes the saw harder to steer accurately.

**thixotropic (adj)**

Thick like a solid or gel in static form. A thixotropic substance flows like a liquid when sideways force is applied – such as mayonnaise being spread on a slice of bread.

**veneer tape (n)**

A thin paper tape, backed with moisture-activated hide glue, that is used to secure the pieces on the show side of a veneer panel. After the panel is glued, the tape is removed through scraping and light sanding. Solid veneer tape is suitable for thick veneers that require more adhesive strength. Thinner, perforated veneer tape allows the user to see the glue line to make adjustments as necessary. **PWM**

**Go Online FOR MORE ...**

You'll find links to all these online extras at:  
▶ [popularwoodworking.com/dec10](http://popularwoodworking.com/dec10)

**ARTICLE:** Read "Screws are Screws – Aren't They?" – free on our web site.

**IN OUR STORE:** Our reprint of and video instruction from the 1889 book "Exercises in Wood-Working."



**WORKSHOP  
MAKEOVER  
GIVEAWAY**

**This  
\$10,000 Workshop  
Could Be Yours!**

**ENTER ONLINE TODAY!**

**Enter for your chance to WIN A COMPLETE SHOP that features ALL you see here.**

ENTRY DEADLINE: Midnight, Eastern Standard Time, May 31, 2011



**JET** 50" TABLE SAW  
Deluxe XACTA  
3HP, LT



**JET** 17" DRILL PRESS  
JDP-17DX



**JET** 15" PLANER  
JWP-15DX



**JET** 6" JOINTER  
JJ-6HHDX



**JET** 1-1/2-HP DUST COLLECTOR  
DC-1100



**JET** 10" SLIDING  
COMPOUND MITER SAW  
JMS-10SCMS



**JET** 14" BAND SAW  
JWBS-14DX

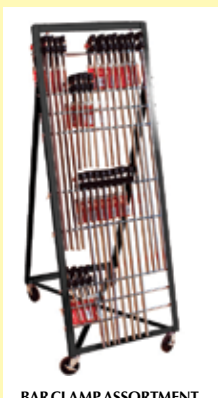

**BESSEY** BAR CLAMP ASSORTMENT  
WITH  
MOBILE RACK  
BTB30A



**BESSEY** 4-PC "H" STYLE  
PIPE CLAMP SET  
BPC-H34



**BESSEY** K-BODY® REVO™  
FRAMING KIT  
KRK2450



**BESSEY** K-BODY® REVO™  
EXTENDER KIT  
KRX2450



**BESSEY** 24" X 4" LIGHT DUTY  
STEP-OVER  
CLAMPS  
LMU2.004

Complete prizes and contest rules are also available at [www.popwood.com/winshop](http://www.popwood.com/winshop)

**[www.popwood.com/winshop](http://www.popwood.com/winshop)**

POPULAR WOODWORKING'S "WORKSHOP MAKEOVER GIVEAWAY" SWEEPSTAKES These are only abbreviated rules. The "Workshop Makeover Giveaway" Sweepstakes is subject to Official Rules available during promotion period (Nov. 1, 2010-May 31, 2011) at [www.popwood.com/winshop](http://www.popwood.com/winshop). See Official Rules for complete entry details and prize descriptions. NO PURCHASE OR SUBSCRIPTION NECESSARY TO ENTER OR WIN. Must be a legal resident of the U.S. or Canada (excluding Quebec) who has reached the age of majority in the participant's jurisdiction of residence to enter. One Grand Prize—Woodworker's Home Workshop valued at US \$10,000. Odds of winning depend on number of entries. Void in Quebec and where prohibited. Sponsor: F+W Media, Inc., 4700 E. Galbraith Rd., Cincinnati, OH 45236 USA.

**ENTER  
NOW!**

The Workshop Makeover  
Giveaway is sponsored by:



BY BRAD GRAHAM

# Too Delicate A Touch

The hands are the tools  
that mean the most.

When I was a professional woodworker, I experienced a satisfying fascination looking at my hands at the end of the day. As a full-time cabinetmaker, I thought about them as I made specialty cuts on the saw, my fingers gliding within a hairsbreadth of the hungry blade. At the end of each shift, I was, of course, relieved that they were still there, that some stupid oversight of fundamental safety on my part hadn't compromised them.

Though I was always glad they were intact, it was the appearance of my hands that appealed to me. They looked worn and used, like a good woodworker's hands should. Skin-like strips of dried glue leprously peeled from the tips of my fingers. Dark crusty islands of wood putty decorated my digits. Cracked, dry and calloused, these were the hands of someone who knew how to get the job done, who knew that a meticulous eye and talented hands could produce something truly exciting from a rough-hewn length of wood. I felt my hands were more impressive than other tools found in the shop.

It is years later now and my hands aren't too impressive any more. My years outside the shop have softened their grip somewhat. The callous that once protected my thumb as I checked the jointed edge of a freshly milled piece has disappeared. The cracks around my nails—that would sting when fresh putty closed over them—have long since healed, leaving soft skin on my fingertips. Indeed, cleaning up my scrap



pile the other day, simply stacking offcuts into an organized pile, my soft paws were left slivered with no less than four different species of wood. The only abuses my fingers now suffer are an occasional neglect of lotion. I was shocked at how pampered they had become.

I'd attempted to organize my pile of scrap wood on a whim. Despite the fact that it had been years since I built anything, I'd been unable to part with the loose pieces of oak, ash, alder and maple that had accumulated in the garage. As any woodworker knows, even the smallest of scraps still maintain promising potential. But the forgotten and cluttered pieces were an eyesore that needed attention.

As I stacked them neatly under the workbench, I looked fondly on the various species, each distinct in character and feel. And that feel is what brought me back—the softness inherent in the alder, the density of the hickory, the graininess of the rift-sawn oak. Simply put, I enjoyed the feel of the wood in my hands once again, so many years after I left the shop. And with the feel, of course, came the slivers.

Yet a flood of long-forgotten memories came back as well. The way I learned that touch was as important as sight in determining the quality of finish sanding. Or the way my fingertips could check

the delicacy of a mitered corner. Or how I found out, the hard way, that the edge of melamine is comparable to a razor knife. An excitement born of nostalgia began as I stared at those chunks of wood. Instead of the cleaning I had planned for that Saturday afternoon, my garage instead became a dusty shop once again. The saws came out, the compressor grunted and coughed, and the router screamed away five years of neglect. A fantastic little alder cabinet was the result.

Of course, as I might have expected, my hands didn't fare too well. But aside from several slivers, and a few cuts and scrapes, they didn't suffer too much, either. All in all, it felt pretty good to once again put them to work, to employ the greatest tool in the shop—despite the fact that they were a little rusty. **PWM**

*Brad is (once again) a woodworker  
who lives in Orem, Utah.*

## Go Online FOR MORE ...

You'll find links to all these online extras at:  
► [popularwoodworking.com/dec10](http://popularwoodworking.com/dec10)

**IN OUR STORE:** James Krenov's "The Impractical Cabinetmaker" and "A Cabinetmaker's Notebook."





# 3000 HOUR SALE ULTIMATE WORKSHOP SWEEPSTAKES

**TIME IS RUNNING OUT TO SAVE BIG AND WIN BIG.**  
The largest woodworking event of the season is wrapping up but there's still time to take advantage of the savings and giveaways on all of our industry-leading machinery, tools, and accessories. Visit [3000hoursale.com](http://3000hoursale.com) for your chance to win one of our 2 Ultimate Workshop Sweepstakes. The clock is ticking. Don't miss out.



**POWERMATIC® ULTIMATE SHOP  
OVER \$5800.00 VALUE**



**JET® ULTIMATE SHOP  
OVER \$5200.00 VALUE**

**VISIT > [3000HOURSale.COM](http://3000HOURSale.COM) FOR COMPLETE  
DETAILS AND TO LOCATE A DEALER!**

©2010 Walter Meier (Manufacturing) Inc. All rights Reserved. The colors WHITE and GOLD are registered trademarks of Walter Meier (Manufacturing) Inc. For more information, go to [PWFREEINFO.COM](http://PWFREEINFO.COM).



# THEY'RE BACK



**NO. 4**  
SMOOTHING PLANE



**NO. 62**  
LOW ANGLE JACK PLANE



**NO. 9-1/2**  
BLOCK PLANE



**NO. 60-1/2**  
LOW ANGLE BLOCK PLANE



**NO. 92**  
SHOULDER / CHISEL PLANE

**Stanley® Revisits A Cherished Era of Quality and Craftsmanship.**

Introducing the new line of Stanley® premium hand planes. Their mechanical precision, simple adjustment features, and top-quality materials are once again worthy of the famous Sweetheart™ logo ... a distinction that professionals and serious woodworkers recognize as a coveted symbol of quality. Not only do these hand planes maintain a tradition of quality and craftsmanship, they also offer a Sweetheart™ price as well.

**Visit a participating Stanley® dealer near you to own yours today.**

For more information, go to [PWFREINFO.COM](http://PWFREINFO.COM).



[stanleytools.com](http://stanleytools.com)