

WOOD[®] Special Interest Publications

101 + Best-Ever

Workshop Projects

2009

43
Time-saving
Shop Tips

47

Organizers for Tools,
Lumber, and Supplies

Build Your Own Shop
Cabinets and Save!

28

Jigs to Make Shop Tasks
Easier and More Accurate

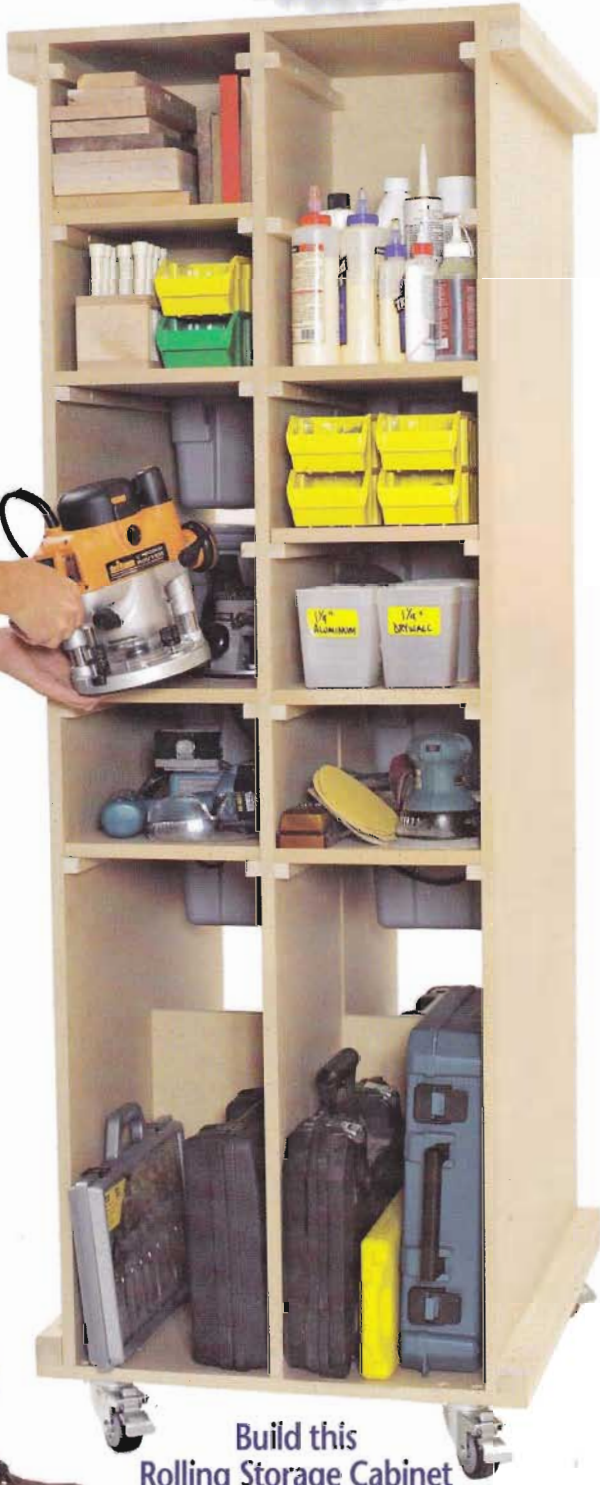
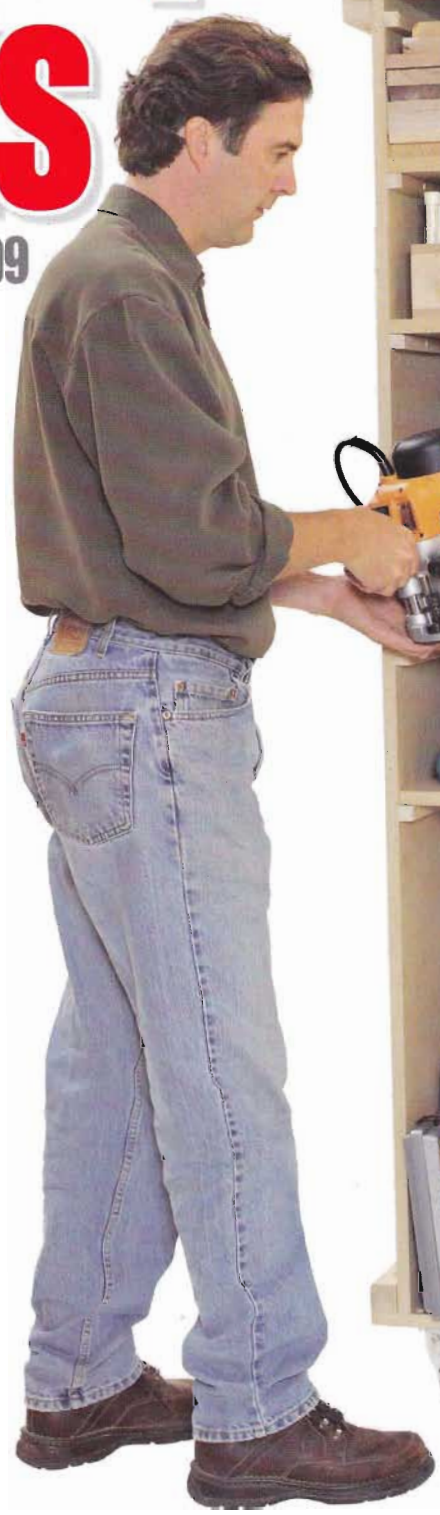

Build this
Rolling Storage Cabinet
in a Day! p.94

Display until November 3, 2009



Better
Homes
and Gardens.

Every issue. Every project. Every tip & technique.

Special
25th
Anniversary
Offer

The Complete **WOOD**® Magazine Collection on DVD.

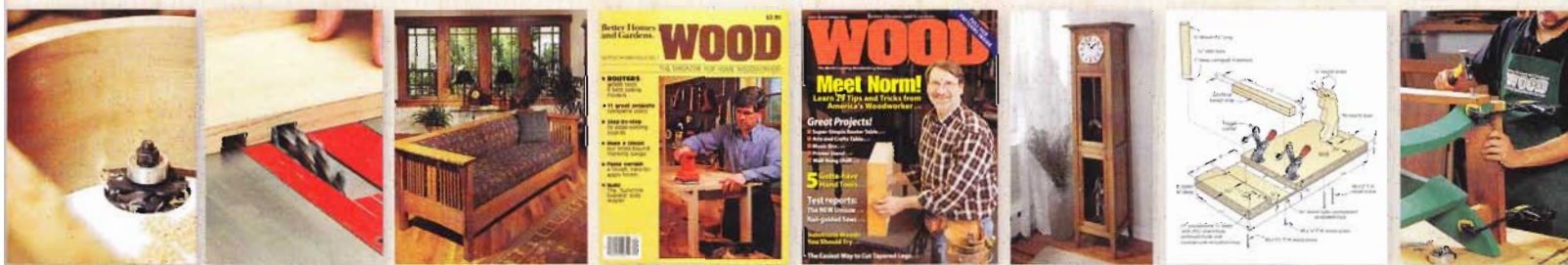

For the first time ever, you can own every issue of **WOOD** magazine from the past 25 years in an easy-to-use, easy-to-search DVD format.

- Thousands of Shop Tips
- 1,100+ projects with detailed instructions
- Hundreds of woodworking techniques

Each high-quality DVD contains five years' worth of **WOOD** magazine.

Volume 1 — 1984–1989 **Volume 3** — 1995–1999
Volume 2 — 1990–1994 **Volume 4** — 2000–2004
Volume 5 — 2005–2009

Buy only the discs you need to complete your collection, or get all 195 issues for one low price. **The more you buy, the more you save.**



Any DVD for \$49.95
 Two DVDs for \$89.95 (**save \$10**)
 Three DVDs for \$119.95 (**save \$30**)
 Four DVDs for \$139.95 (**save \$60**)
 All five DVDs for \$149.95 (**save \$100**)
 plus shipping & handling

BEST VALUE!
 Like getting
 2 DVDs **FREE!**

Preorder online at woodmagazine.com/DVDlibrary or by phone at **888-636-4478**

Volumes 1 to 4 will ship in 2-4 weeks.

Volume 5 will ship in November upon completion of the final 2009 issue.

101BEWP09



A hundred great shop ideas—and then some

In my single-stall garage shop, I crank out three or four pieces of furniture each year, along with dozens of holiday, wedding, and other gifts. So my limited-space work area has to be extremely well-ordered. The organizers, jigs, racks, and other helpers in this publication will help you maximize your own shop's space and efficiency. They've all been tested in the *WOOD*® magazine shop, so you know you can rely on the results. Why am I so confident that you'll benefit from these shop-made projects? Because I use many of them, like the two shown *below*, in my own garage. If your shop needs a little sprucing up or reorganizing, you'll find more than 120 projects to make that happen.



Marlen Kemmet

Marlen Kemmet
WOOD magazine Managing Editor



Better Homes and Gardens®

WOOD
MAGAZINE

101+ Best-Ever Workshop Projects 2009

woodmagazine.com

Editor-in-Chief **BILL KRIER**
Managing Editor **MARLEN KEMMET**
Deputy Editor **DAVE CAMPBELL**
Publication Editor **A.J. HAMLER**
Techniques Editor **BOB WILSON**
Tool & Techniques Editor **BOB HUNTER**
Multimedia Editor **LUCAS PETERS**
Multimedia Editor **CRAIG RUEGSEGGER**
Senior Design Editor **KEVIN BOYLE**
Design Editor **JEFF MERTZ**
Production/Office Manager **MARGARET CLOSNER**
Administrative Assistant **SHERYL MUNYON**
Photographers **JASON DONNELLY, SCOTT LITTLE, JAY WILDE**
Contributing Illustrators **TIM CAHILL, LORNA JOHNSON, ROXANNE LEMOINE**
Contributing Craftsman **JIM HEAVEY**
Contributing Proofreader **IRA LACHER**

Art Director **KARL EHLERS**
Project Art Director **DESIGN MATTERS**
Associate Art Director **GREG SELLERS**

SUBSCRIBER SERVICE Go to woodmagazine.com/help or write to *WOOD* magazine, P.O. Box 37439, Boone, IA 50037-0439

Publisher **MARK L. HAGEN**

ADVERTISING AND MARKETING

CHICAGO: 333 N. Michigan Ave., Suite 1500, Chicago, IL 60601

Marketing Manager **AMANDA SALHOOT**
Advertising Manager **JACK CHRISTIANSEN**
Direct Response Advertising Representative **LISA GREENWOOD**

Assistant **TIM BAARDA**
ATLANTA: Navigate Media
DETROIT: RPM Associates

Business Manager **JEFF STILES**
Consumer Marketing Director **TODD BIERLE**
Associate Director of Marketing-Newsstand **TOM DEERING**
Production Manager **SANDY WILLIAMS**
Advertising Operations Manager **JIM NELSON**
E-Commerce Manager **MATT SNYDER**

Vice President/Group Publisher **TOM DAVIS**

MEREDITH PUBLISHING GROUP

President **JACK GRIFFIN**
Executive Vice President **DOUG OLSON**
Chief Revenue Officer **TOM HARTY**
Finance & Administration **MIKE RIGGS**
Manufacturing **BRUCE HESTON**
Consumer Marketing **DAVID BALL**
Corporate Sales **MICHAEL BROWNSTEIN**
Meredith 360° **JEANNINE SHAO COLLINS**
Interactive Media **LAUREN WIENER**
Corporate Marketing **NANCY WEBER**
Research **BRITTA WARE**
Chief Technology Officer **TINA STEIL**
New Media Marketing Services **ANDY WILSON**
Direct Response and Travel **PATTI FOLLO**



President and Chief Executive Officer **STEPHEN M. LACY**
Chairman of the Board **WILLIAM T. KERR**

In Memoriam — **E.T. Meredith III (1933-2003)**

©Copyright Meredith Corporation 2009. All rights reserved. Printed in the U.S.A.
Retail Sales: Retailers can order copies of *WOOD* for resale by e-mailing jennifer.buser@meredith.com.

101+ Best-Ever Workshop Projects 2009

4–38 **Hardworking Jigs and Accessories**

A good woodworking jig matched with the right tool brings both efficiency and added safety to your woodshop pursuits. This collection of 28 jigs fits the bill.

40–68 **Supports, Stands, and Worksurfaces**

These 23 easy-to-make projects keep shop tools (and workpieces) as steady as can be. From benches and folding tables to tool caddies and mobile assembly stations, these helpers will give you a hand every time you step into the shop.

70–93 **Racks for Tools, Clamps, and Lumber**

Every shop needs a good place to store bulky tools and materials. These 22 projects keep tools and lumber out of the way but still ready to go at a moment's notice.

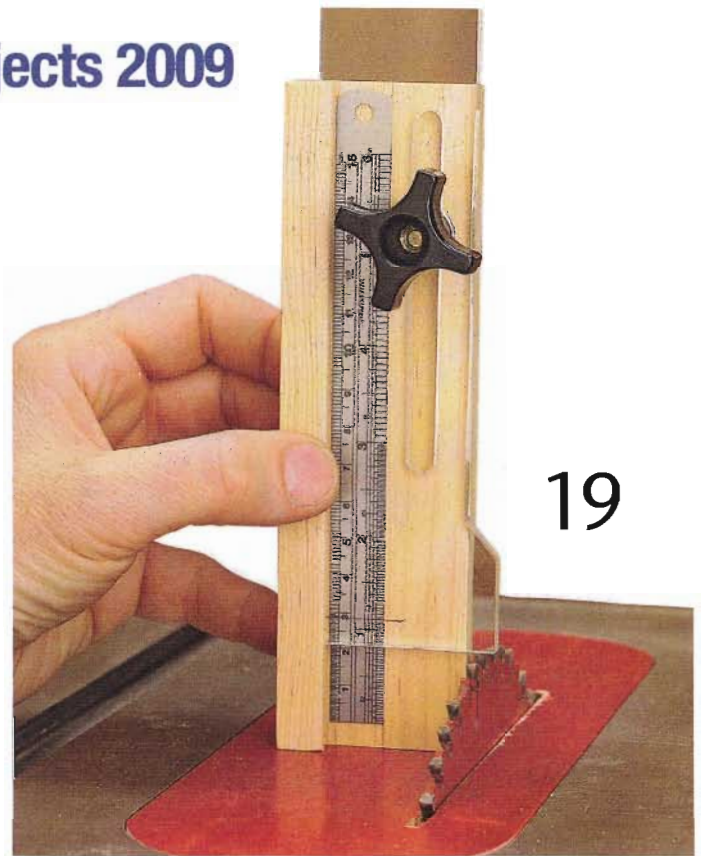

19



109



46

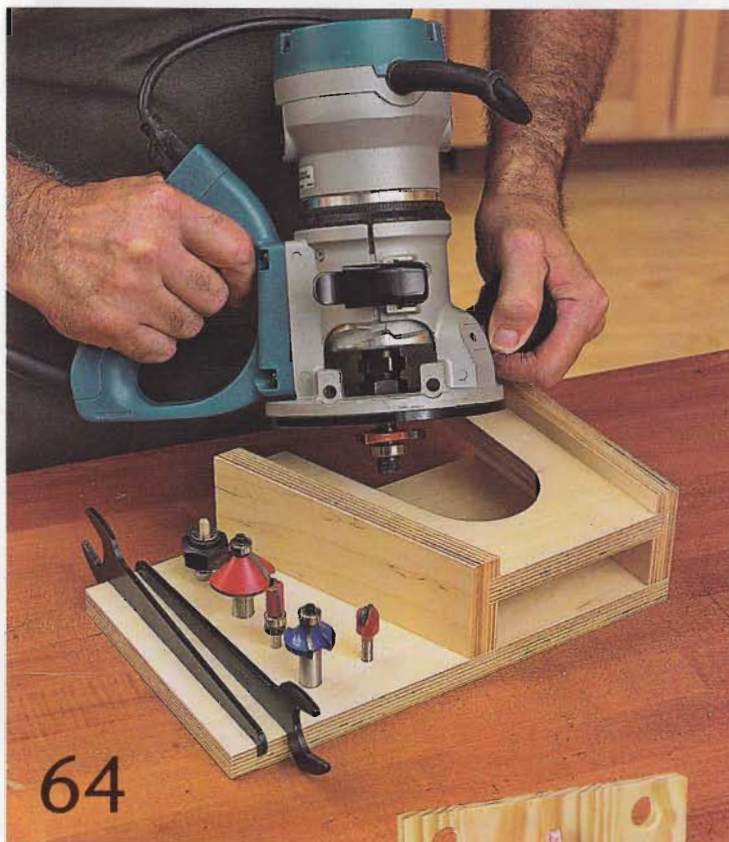

64

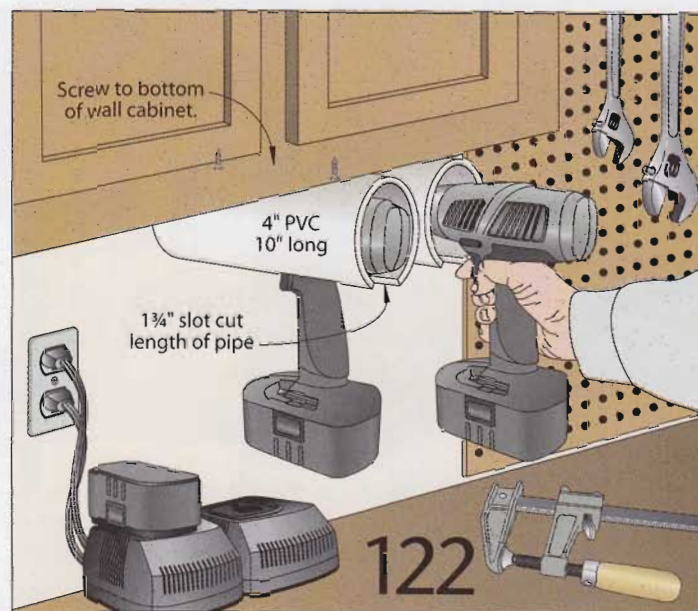

102



94–115 **Hardware and Accessory Storage**

With well-designed storage for hardware, fasteners, small accessories, and countless other supplies, you never have to stop working to hunt down these small items. Here are 22 clever projects that ensure efficiency, even in the busiest shop.

116–128 **Shop Tips**

Short and sweet, these 29 project-oriented hints, ideas, and tricks offer fast solutions to just about any workshop situation. You'll be surprised—and pleased!—at just how quickly these tips can come to the rescue in your shop.



89

79



Hardworking Jigs and Accessories

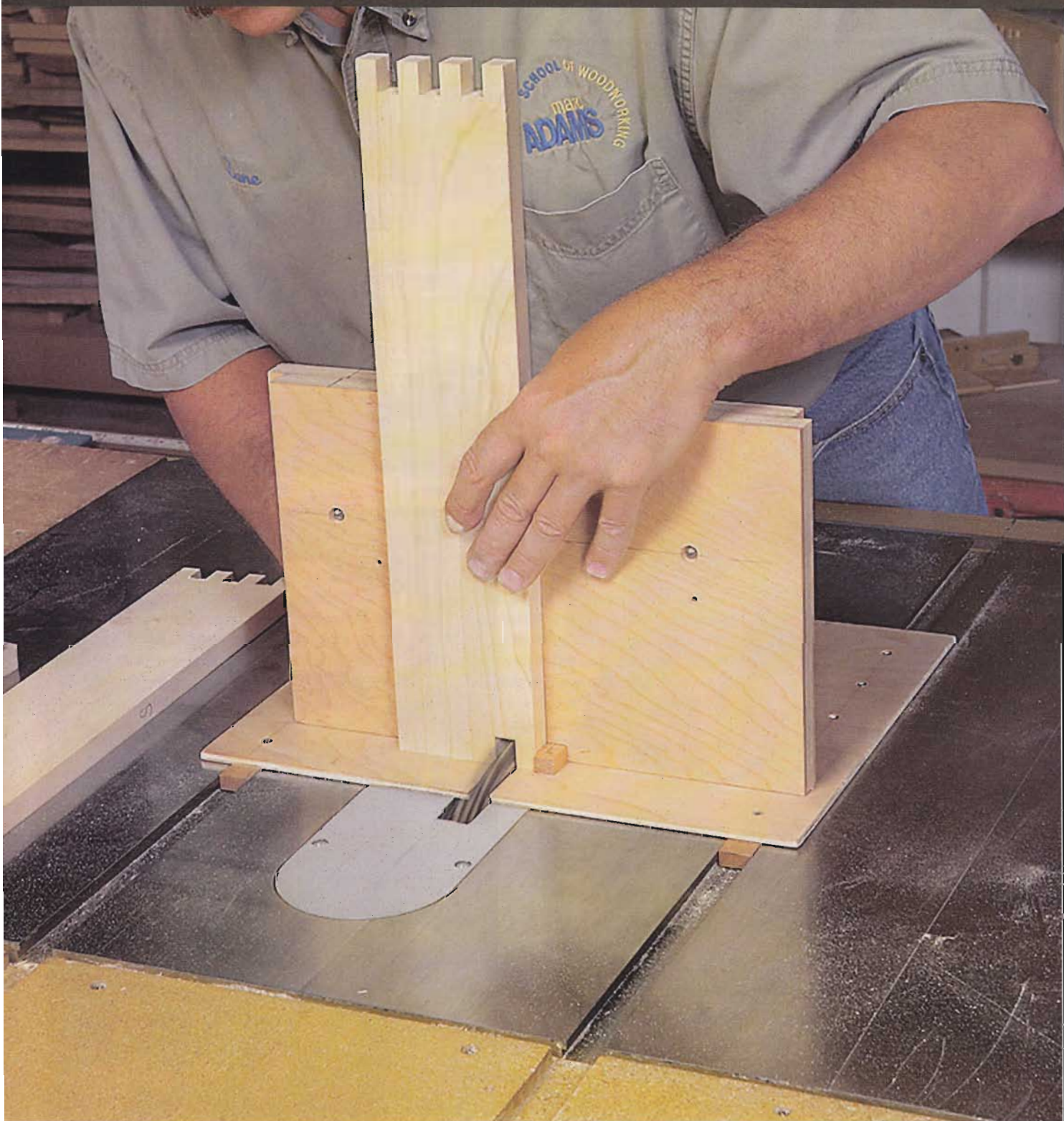

THE NEXT BEST THING TO THE TOOL ITSELF A good woodworking tool becomes a great one when you team it up with a well-designed and fitted jig. There's just no better way to get safe, repeatable results.

Quick, reliable **box-joint sled**

Box joints are strong, attractive, reliable—and often complicated to produce. This tablesaw jig makes them easy.

Sometimes mistakenly referred to as a finger joint, the box joint features good looks and great strength. A well-made one consists of crisp, interlocking rectangular fingers that fit snugly together. To achieve this, setup is critical, and this jig provides the adjustment capability you need, regardless of how wide or thick your workpiece. And by merely switching adjustable fences, you can use the basic sled for different-size fingers. The overall dimensions of the jig can vary depending on the length and width of your tablesaw's top or your available scrap. The drawing provides recommended sizes. The size of, and the width between, the runners depends on the dimensions and spacing of your saw's miter-gauge slots.

Building the jig

Cut the base to size from $\frac{1}{4}$ ", $\frac{1}{2}$ ", or $\frac{3}{4}$ " material. Now cut two miter-gauge runners to the height and width of your slots, each

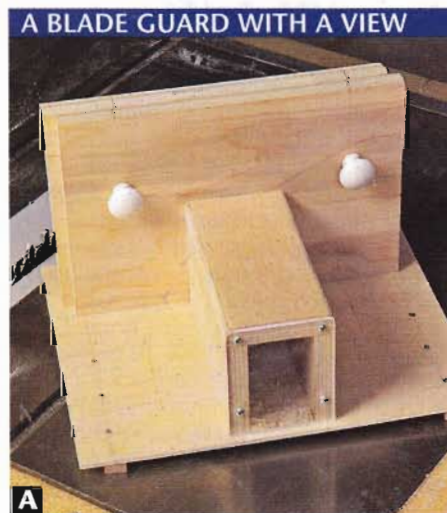
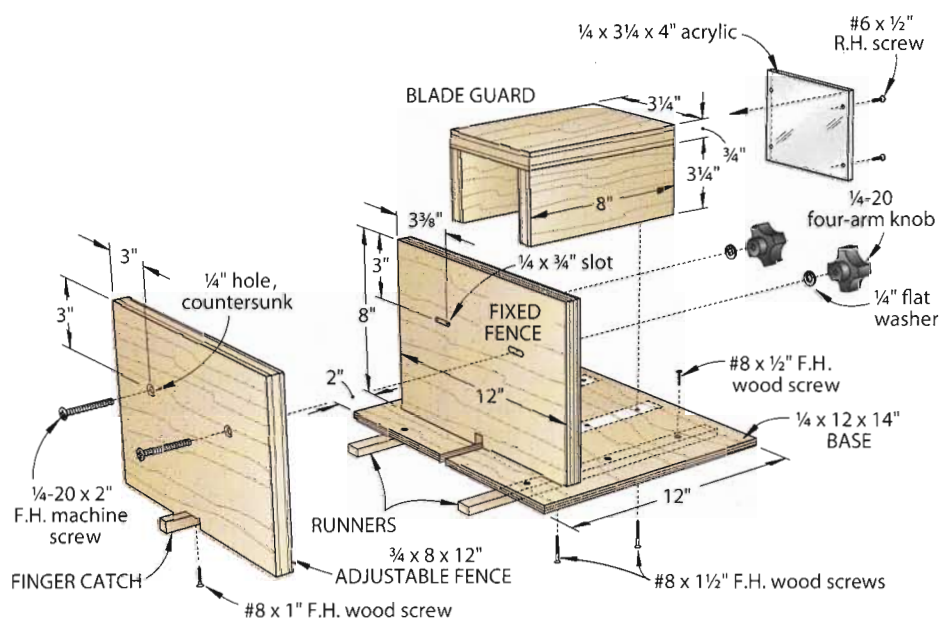

An acrylic back to the blade guard gives a clear view of the blade inside, serving as a reminder not to saw through the jig. Four screws hold the piece in place.

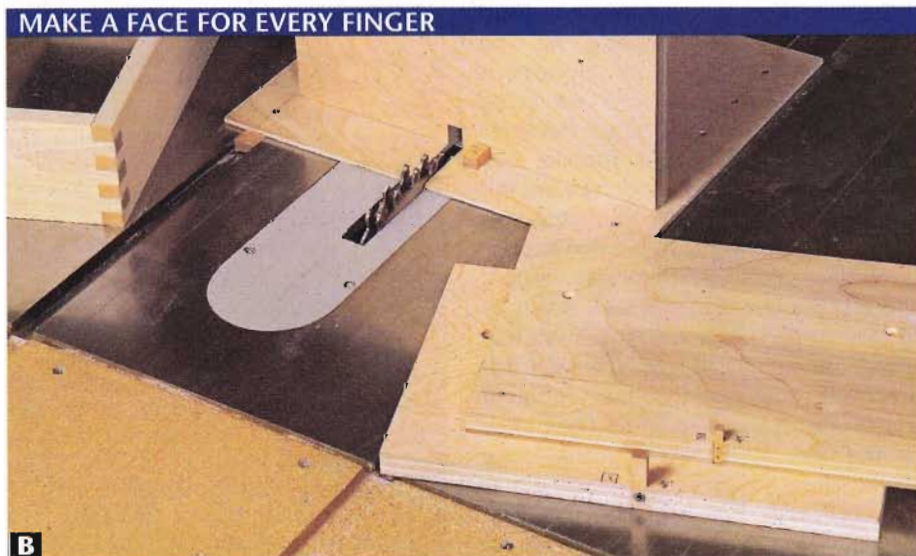

For utmost versatility, make several easy-to-add front faces for every size box joint you commonly make. These attach with machine screws, washers, and knobs.

SET UP FOR PRECISION CUTS

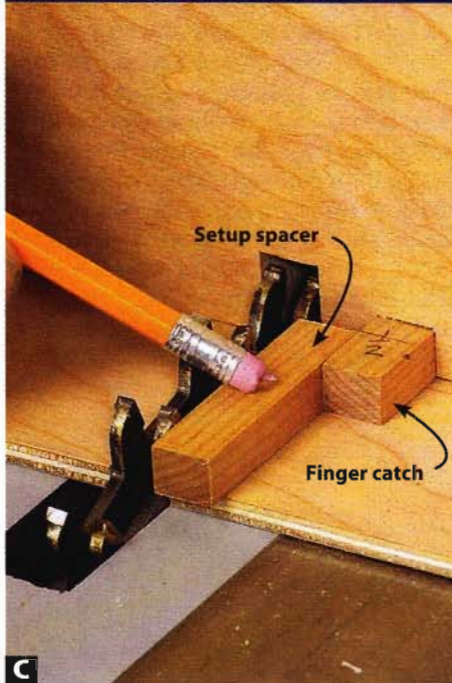

To establish the precise location of the finger catch and adjustable fence, place a setup spacer between the saw blade and catch.

CUTTING MATING FINGERS FOR A SNUG-FITTING JOINT

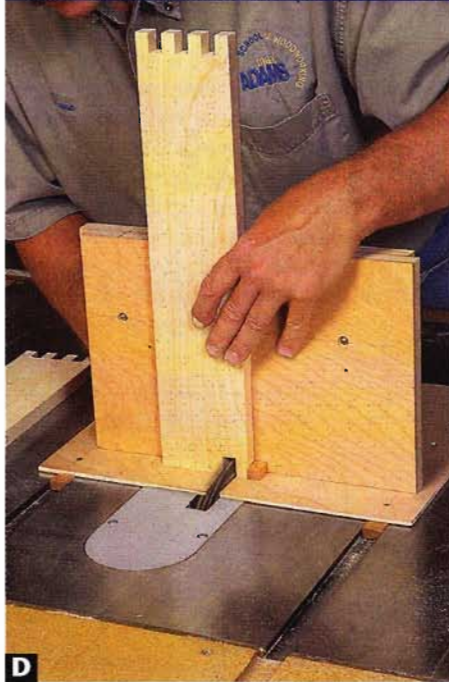

With the edge of the workpiece against the finger catch, cut the first notch. Slip the notch over the catch to cut succeeding notches.

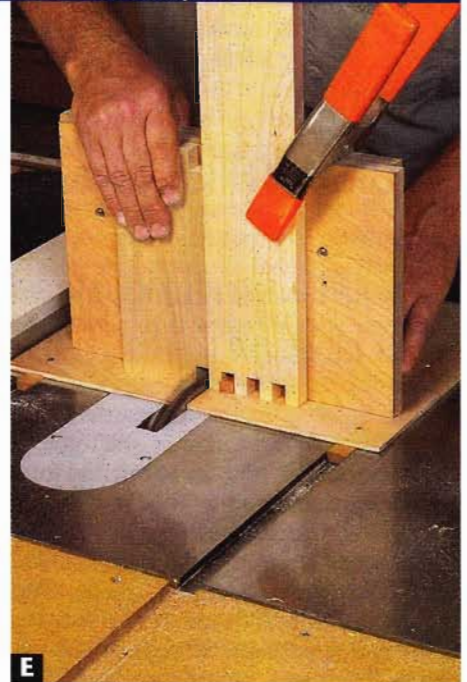

Use the notched first workpiece, as shown, to establish the location of the beginning (open) notch to be cut in the mating workpiece.

at least 14" long. Test the fit in the slots, avoiding any play. Use your saw fence to square the sled base, locating the saw blade at the center of the base. With the runners extending 2" beyond the front edge of the base, and with the base flat on the saw top, attach the runners. If you have an 18-gauge brad nailer and $\frac{5}{8}$ " nails, you can temporarily pin the base to the runners to make sure everything remains square. Then drive $\frac{1}{2}$ " wood screws through the base and into the runners for strength.

Cut two fences to size—one a fixed fence, the other an adjustable one. The fences must be rigid, so $\frac{3}{4}$ " plywood is best. Drill and cut out the $\frac{1}{4} \times \frac{3}{4}$ " slots in the fixed fence where shown. Attach this fence perpendicular to the base, spacing it 2" behind the front edge. You don't want this assembly to move at all, so glue and screw the fence very securely to the sled base.

Next, for safety and fixed-fence support, add a blade guard to the sled. Begin by cutting the parts to size, and assemble it as shown using glue and screws. Now, screw the blade guard to the base, fitting it snugly against the fixed fence. Then, close up the back of the blade guard. Using acrylic allows you to see any small pieces of wood inside that can bind the dado blade, and you're much less prone to cut through the acrylic back plate, making the jig even safer. (See **Photo A**, previous page.)

Completing the sled for dead-on box joints

To finish the sled, install your dado blade in the saw and set it to the width of the fingers you intend to cut. Raise the top of the blade $\frac{1}{2}$ " above the sled base and make a single pass to create the initial kerf in the fixed fence. To avoid cutting through the back of the blade guard, insert and

clamp stops into the tablesaw miter slots to limit sled travel.

Clamp the adjustable fence to the fixed fence, with the bottom edge and ends flush to the sled base. Now, make another pass with the dado blade to create an opening equal to the desired finger width. Cut a 4"-long, $\frac{1}{2}$ "-thick piece of wood to the exact width of the intended fingers. Now

More Secrets for Box-Joint Success

- Before cutting the fingers for your project, take a few minutes to lay out how the joints will go together. As the joint at upper left of **Photo B** shows, the sides of the box are cut closed, meaning they have a finger on top of each corner of the box. The ends of the box are open, as they start with a slot.

Label the top edge of each board, indicating which side goes against the finger catch. Cut both ends of each side first, as they have the same starting point. Then, cut the fingers on the end pieces last, as they need one of the side pieces positioned over the finger catch to cut the first slot.

To alternate the top finger at each corner to give the piece a different look, mark each workpiece clearly so you know whether to cut each end

open or closed. Cut all closed ends first and then all open ends.

- The artistic aspect of cutting box joints lies in the dimensions and layout of the fingers. You'll achieve the best results when all the box fingers are of equal width. To get these results, simply select a finger width that evenly divides into the total width of the box sides. For example, if the box has 5"-high sides, then $\frac{1}{2}$ "-wide fingers would mean you will have 10 perfectly spaced fingers at each corner.

- Once you have cut fingers wider or longer than the ones you are cutting now, add a backer between the front face of the adjustable fence and workpiece to preserve the sharp, crisp edges of the fingers. Scrap $\frac{1}{4}$ "-thick lauan plywood works well for this.

cut it into two pieces: one 1½" long; the other, 2½" long. Use the shorter piece for the finger catch on the adjustable fence. The longer piece will be your setup spacer when positioning the adjustable fence on the sled. Glue and screw the finger catch into the opening on the adjustable fence, flush with the back face. It's a good idea to make an adjustable front fence for each finger width you want to make the jig more versatile, as shown in **Photo B** on page 5.

To position the adjustable fence accurately, first place it against the fixed fence and slide the sled forward until the dado blade is next to the finger catch. Place the setup spacer between the blade and finger catch, as shown in **Photo C**. Now, clamp the adjustable fence to the fixed fence and drill two ¼" holes through the adjustable fence, centering them in the fixed-fence slots. Finally, insert machine screws through the holes and slots, adding the washers and knobs. (The version in the photos uses drawer knobs, but we've illustrated some better-suited four-arm knobs in the drawing—the choice is yours.) Make a cut through the adjustable fence and check it.

Cutting box-joint fingers

The length of box-joint fingers equals the thickness of the mating sides, so you have to adjust the dado-blade height accordingly. (See *More Secrets for Box-Joint Success*, *opposite*.) When setting up for actual depth, it's better to err on the side of making the fingers too long. That way, once you glue the joint, you easily can sand the ends flush because they stand proud of the mating sides. Cut the sides and ends of the box ⅛" longer than the plan calls for. Then, set the blade height 1" higher than the thickness of the boards. After gluing and assembling the joint, sand away the extra finger length. This results in perfect-fitting joints with glass-smooth faces.

Now, test-mill two scraps of wood of the exact thickness. Place the first workpiece (outside face out) on the jig with one edge snug against the finger catch and one end resting on the sled base. It is absolutely critical at this point that you hold the workpiece firm and motionless. Make your first pass through the saw, as shown in **Photo D**. Slide the sled back from the blade, reposition the workpiece by slipping the

notch you just cut over the finger catch, and make the second cut. Continue cutting notches till you have cut out all the fingers across the entire end of the test workpiece.

To cut the corresponding fingers in the mating test workpiece, flip the first board around so that its front face now rests against the adjustable fence, with the first slot you cut fitted over the finger catch. Place the second test workpiece edge-to-edge against the first and make the first pass through the blade, as shown in **Photo E**. Complete the cuts using the step-and-repeat process used earlier until you have cut all the fingers.

Finally, fit the mating workpieces together. If the fingers seem tight or fail to interlock, the space between the finger catch and the dado blade is too wide. Loosen the knobs and slide the adjustable fence a hair closer to the blade. Retighten. If you have play between the fingers, move the adjustable fence a hair away from the blade. Repeat the test until you get a snug fit. Now, you're ready to glue up the joint.

Project design: **Zane Powel, Indianapolis**

Tablesaw pattern jig

Attach this jig to your saw's fence to easily duplicate parts

Some project components, such as the back slats for Adirondack chairs, require numerous angled or tapered cuts. This simple pattern jig turns out those parts in a snap.

Begin by making a plywood pattern to match each piece that requires tapered cuts. Then, fasten the pattern to the stock with double-faced tape or screws. With a little planning, you may be able to position the pattern screws exactly where you'll later make screw holes in the finished piece, meaning you won't have to fix any extra holes required by the pattern.

Now, make a pattern-cutting jig by screwing together two pieces of plywood,



as shown on the drawing. Clamp the jig to your table saw's rip fence, and position the jig edge just a scant ⅛" beyond the edge of the blade.

With everything secured, just slide each pattern/stock assembly along the fence to duplicate the parts, reusing the pattern as needed to complete the project.

Project design: **WOOD Staff**

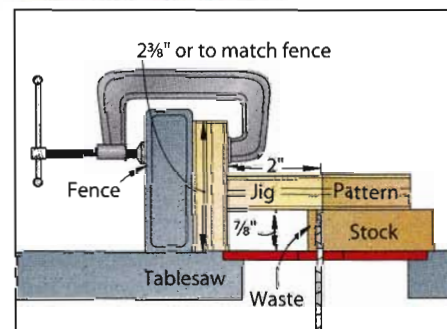

Safety-minded thin-strip ripper

Cutting narrow stock for edge trim and other purposes is a breeze with this safety-minded jig.

If you've cut multiple thin strips of wood all to the same thickness, then you know how difficult and dangerous an operation it can be. This thin-strip ripper combines the functions of a guide fence and a pushblock to perform this function both quickly and safely. Because the jig has only four parts, you can build it in less than an hour.

Rip a piece of 5/4 or 6/4 stock to 5" wide and 22" long. You want the ripper broad enough to fit comfortably between the saw fence and the blade without the saw's blade guard interfering with the operation. Adjust the width if necessary. It's important that you cut the jig to an exact whole-inch measurement, to make setting the strip thickness easy. For example, with a 5"-wide jig, you can set the saw fence to exactly 5 1/8" to cut 1/8" strips.

Next, crosscut the base extension to size and then bandsaw stepped notches into one end, where shown in **Drawings 1** and **1a**. (The notches make room for the pivoting toggle and provide a positive stop as you rotate it into the horizontal position to support your workpiece when cutting thin strips.) Note that the pivoting toggle

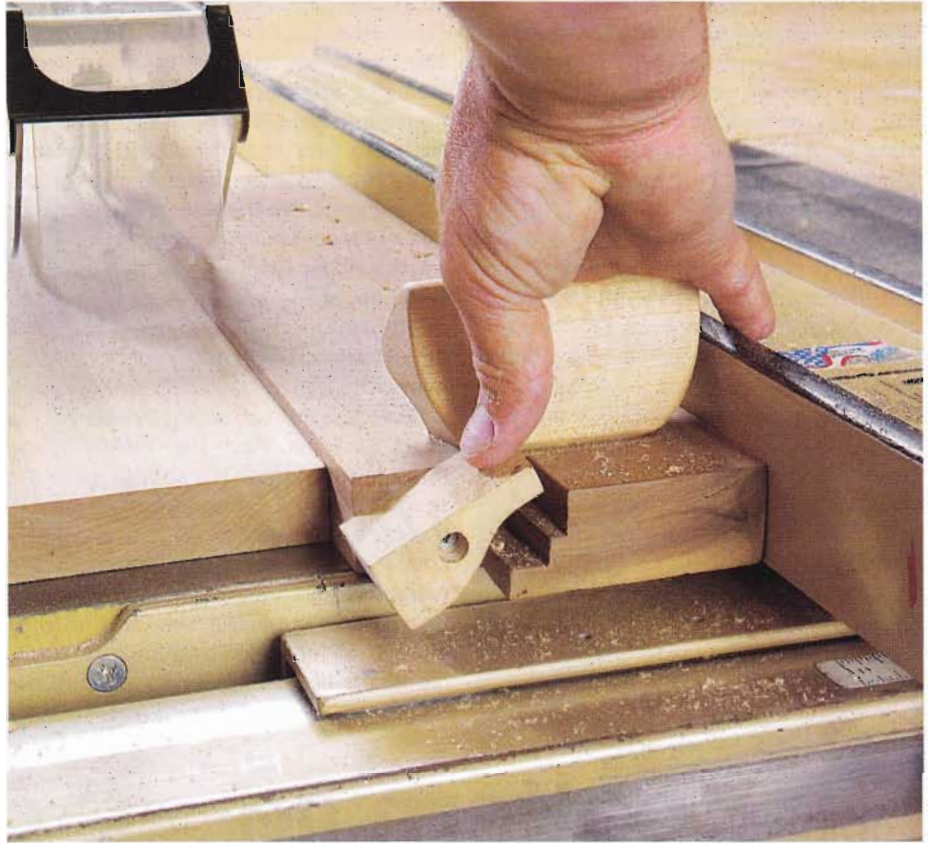

and the maximum width of the notches are both 2 1/4", but the toggle is installed with a 1/8" gap between its end and the end of the notch. Now, glue and clamp the base extension to the end of the base.

Cut the pivoting toggle to size and counterbore a 3/8" hole into the back face

of the toggle, 1/4" deep. Drill a shank hole through the part for a #10 panhead screw. Then, drill a pilot hole into the end of the base as shown on **Drawing 1** and **1a**. Screw the toggle in place so it rotates easily.

Mill the two-part handle to the dimensions shown, including the round-overs,

RIPPING STRIPS IN TWO STEPS

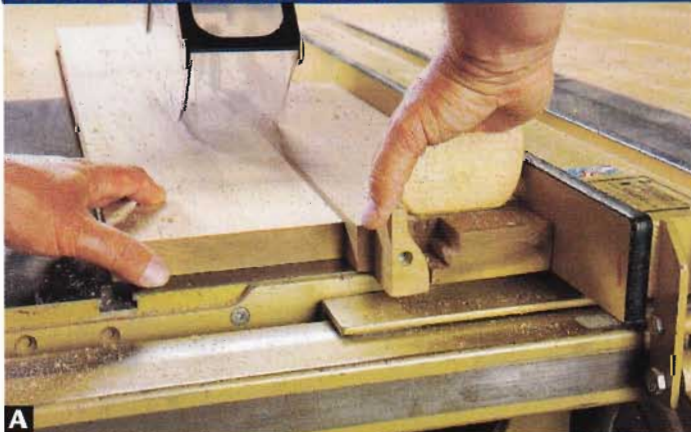

A First, use the base of the thin-strip ripper as a fence by sliding the workpiece along its edge after setting up the desired strip width.

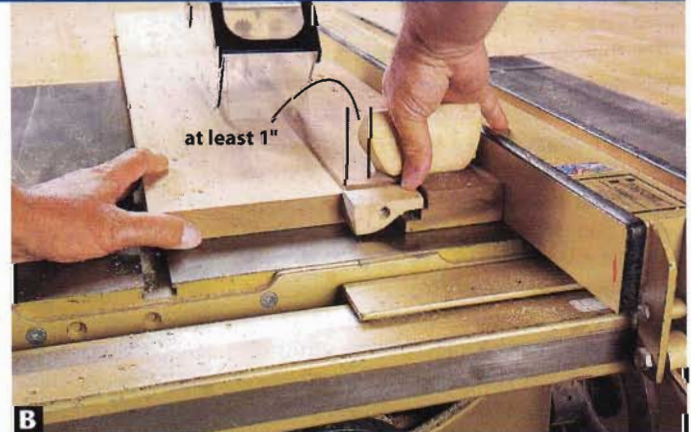

B As the cut proceeds, drop down the toggle to serve as a ledge for supporting the workpiece and safely completing the cut.

Tablesaw tapering jig

Here's an easy way to make repeatable angled rip cuts.

If you don't have a tapering jig for your tablesaw, you easily can make one from scrap to safely and accurately cut tapers on legs and other angled workpieces.

Referring to the drawing, cut the base and three cleats to the sizes shown from $\frac{1}{2}$ " plywood. Cut the handle from $\frac{3}{4}$ " scrap. Drill mounting holes and screw the handle to the base, where dimensioned. Using a tapered table leg as an example, you'll want to mount the cleats to the base so they are snug against it. Adhere the leg to the base with cloth-backed double-faced tape, aligning the top and bottom of a marked tapered side of the leg with the edge of the base, where shown. Make sure you position the leg with one mortise down and the other facing the blade. Then screw-mount the cleats to the base, where dimensioned, tight against the leg.

With the leg still taped to the base, position your tablesaw fence to align the edge of the base flush with the inside face of the blade. Cut the taper, as shown in the photo. Then, rotate the leg to align the second marked side with the base, and cut again. To keep the legs securely attached, replace the tape as needed.

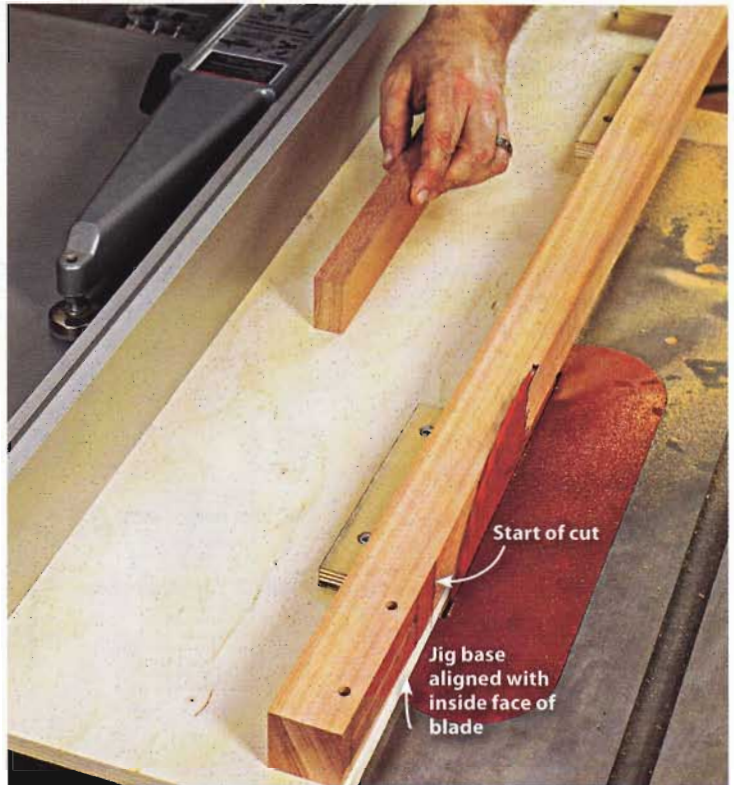

Project design: **Jeff Mertz, Design Editor, WOOD® magazine**

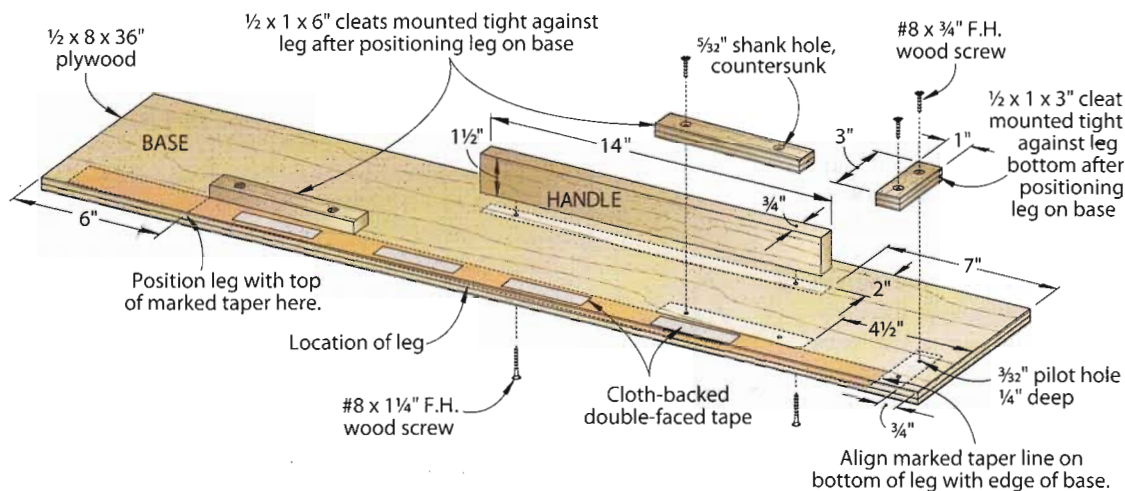

Watch a FREE 11-minute video using three other tablesaw jigs at: woodmagazine.com/tsjigsvideo



Tenon **cheek-cutting** jig

A perfect solution for safe, vertical cuts.

One of the trickiest (and potentially most dangerous) operations on the tablesaw is making cuts into the end of a board stood vertically. The typical tablesaw fence stands too low to provide adequate support when holding the workpiece this way. That's why many woodworkers bandsaw these delicate cuts and try to sand the cut tenons to perfection, or spend more than \$100 to buy a commercial tablesaw tenoning jig. But this tenon-cheek-cutting jig provides absolute accuracy and safety for the cost of two toggle clamps (and free stock from your scrap bin).

The jig rides on both the fence and saw table, as shown at right. It's absolutely critical that the jig holds the workpiece firmly. Flexing will ruin your tenons, so use only 3/4" cabinet-grade plywood for the jig's box and fence assembly.

Note: The design shown here is based on a tablesaw fence with parallel sides such as a Biesemeyer-style fence. If your fence does not have this feature, you can secure the basic saddle assembly to a sliding base mounted on runners that ride in the miter slots, or a base that slides along the fence.

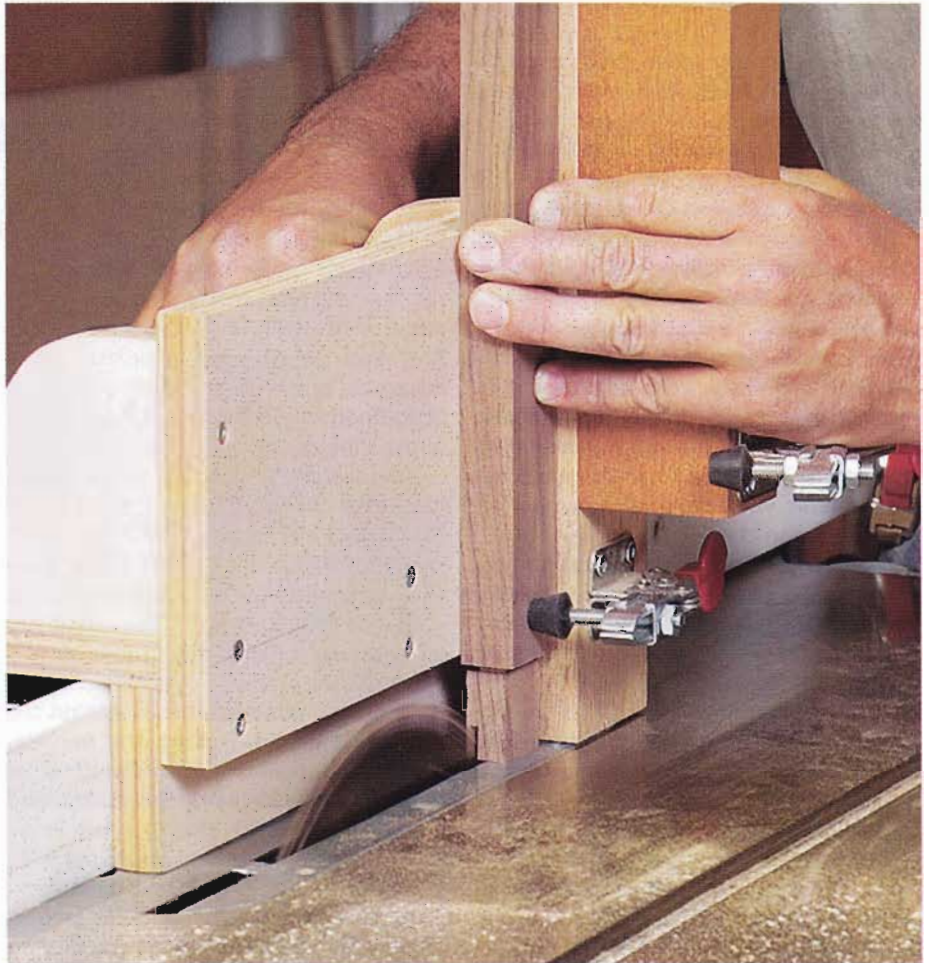

CUTTING CLEAN, STRAIGHT FACE AND EDGE CHEEKS

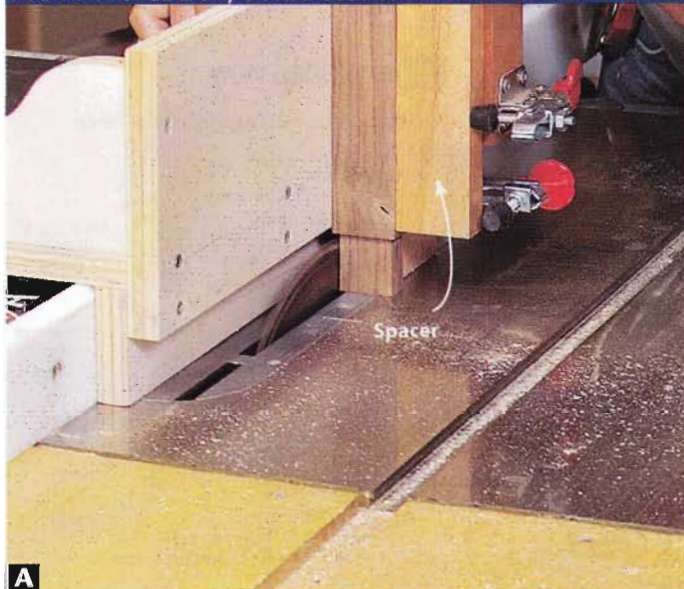

A When cutting edge cheeks, a spacer placed between the opposite edge and outer clamp helps to achieve a firm hold.

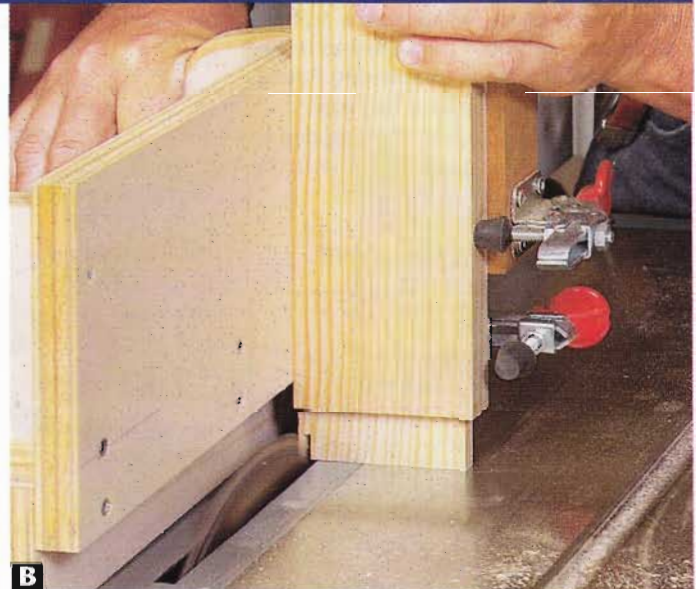

B On wider stock, the outer clamp secures the workpiece without a spacer when cutting edge cheeks.

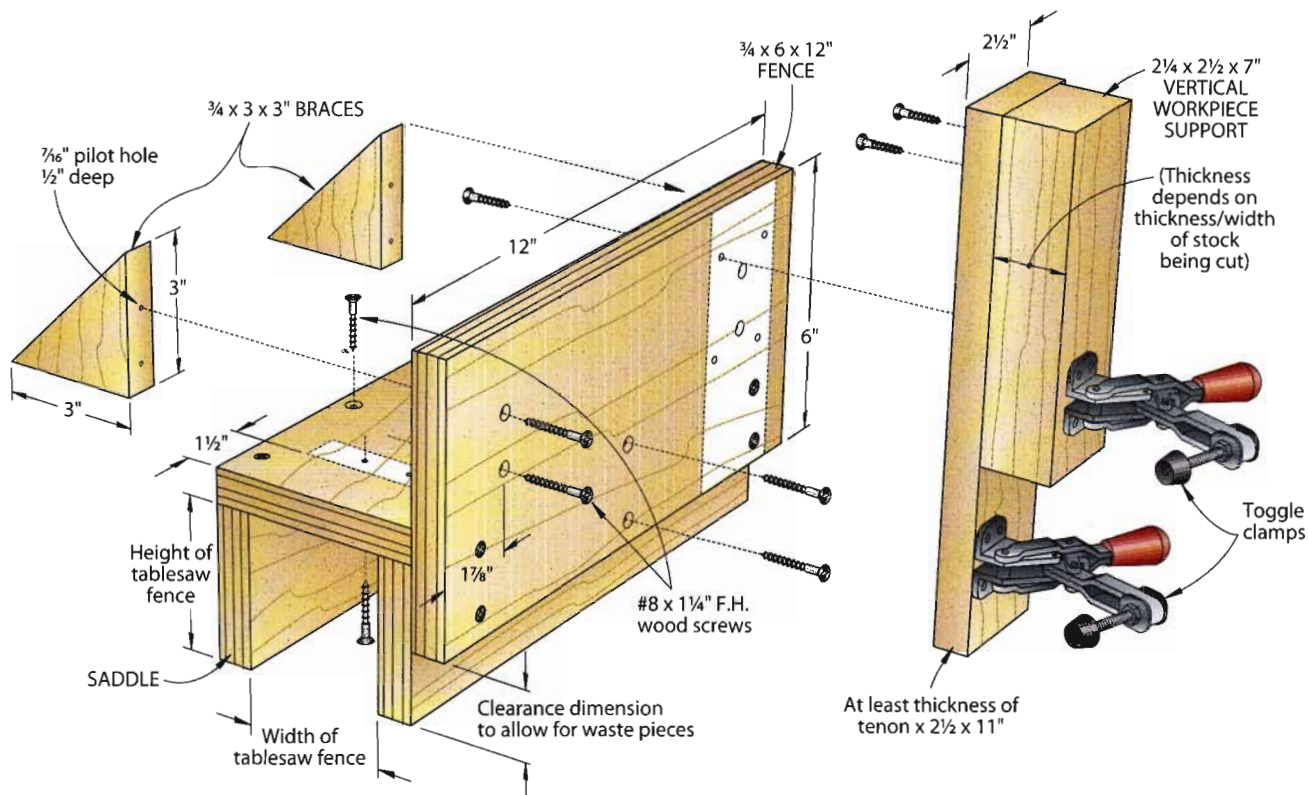

Using the drawing, cut the sides of the saddle to the exact height of your tablesaw fence. Cut the top of the saddle to span both sides when they sit flush against the fence. Glue and screw the top to the sides, ensuring perfect alignment.

Cut this jig's fence and braces to size and then glue and screw them to the base. (The clearance area makes room for the waste while avoiding binding and kickback problems.) Don't skimp on screws, as this assembly must be rigid and dead true.

Finally, cut and glue up the parts for the vertical workpiece support. It accommodates boards of varying widths. The first (inside) piece is $\frac{3}{4}$ " thick, the second $2\frac{1}{4}$ ". Note that these dimensions may vary, depending on the dimensions of the stock cut. Glue them together, leaving the thicker piece about 4" shorter than the thinner one. Glue and screw this assembly to the fence and add low-silhouette toggle clamps. (Get them from woodworking specialty stores or catalog such as Woodcraft: 800-225-1153, woodcraft.com.)

Now, cut dead-on tenons

Set the jig by adjusting the saw fence to cut the inside cheek of the workpiece. If your shoulders have equal depth, you can cut all four cheeks without needing

to reposition the fence. When cutting the face cheeks, be sure to lay the workpiece flush to the fence and secure it with the lower clamp, as shown in main photo, *opposite*. When cutting the edge cheeks, add a spacer board for relatively thin stock and clamp it with the outer clamp (**Photo A**). If the workpiece is wide enough, the upper clamp will hold it in place without a spacer, as shown in **Photo B**.

When cutting tenons, the first cuts you typically make are the shoulder cuts. Keep in mind that if you set your blade too high on a shoulder cut, you'll create a shallow kerf in the tenon that will be hidden when the joint is assembled. On the other hand, if you set the blade too high on the cheek cuts, you will cut a kerf into the finished piece that will be visible where the two pieces are joined.

To ensure results the next time you use the jig, it's always a good idea to keep a mortised mating piece on hand to test-fit the tenon while fine-tuning saw setups. Once you achieve that first snug-fitting mortise-and-tenon joint, you're ready to cut all of the tenons of that size needed for your project.

Project design: **Zane Powel, Indianapolis**

Tenon-size Guidelines

When figuring tenon size, keep in mind the thickness of your workpiece, the widths of the chisels and drill bits you own, and the purpose for which you're using a mortise-and-tenon joint. Consider the basics:

- Apply the rule of thirds. For $\frac{3}{4}$ " stock, that means making a $\frac{1}{4}$ "-thick tenon with $\frac{1}{4}$ " shoulders along each side.
- Regarding tenon width, make top and bottom shoulders the same depth as the side shoulders. This lets you cut all four shoulders using the same setup.
- For full strength, make tenon lengths as long as two-thirds the width of the mating mortised workpiece. Err on the side of creating more gluing surface. The longer the tenon, the stronger. Application is your best guide. In a small picture frame, a short "stub" tenon may suffice. Where racking may occur, as in a table leg/apron joint, opt for a deeper tenon.

Easy-lock feather board

Get perfect rip cuts with this quick-to-set tablesaw helper.

When ripping stock on your tablesaw, keep your workpiece firmly and safely against the fence with this handy adjustable locking feather board. Not only does it prevent wavy cuts, it also guards against dangerous kickback.

To build one, use the half-size patterns in **Drawing 1** below and **Drawing 2** on the next page to cut the handle (A) and feather board (B) to size and shape, noting the location of the angled notch and counterbored hole in the handle. Use a bandsaw to cut the 2½"-long kerfs in the feather board and the curved portion of the handle. Cut the 30° angled notch in the bottom edge of the handle edge using a dado blade in your tablesaw along with an auxiliary wooden fence on your miter gauge for support.

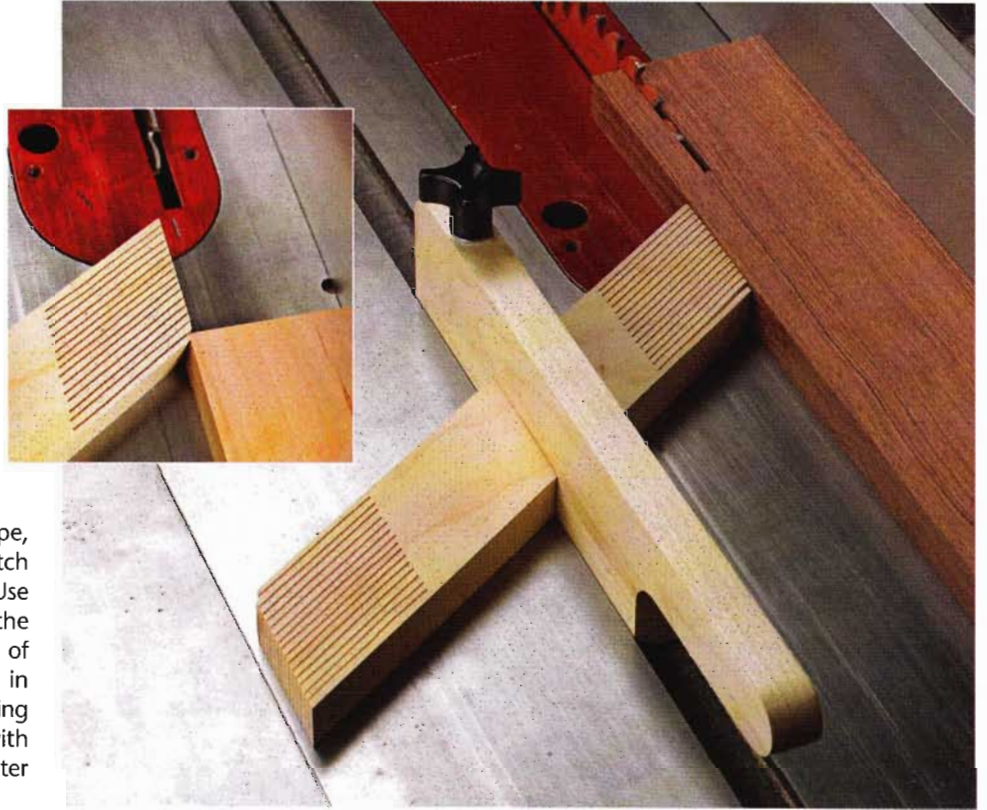

1 PARTS VIEW

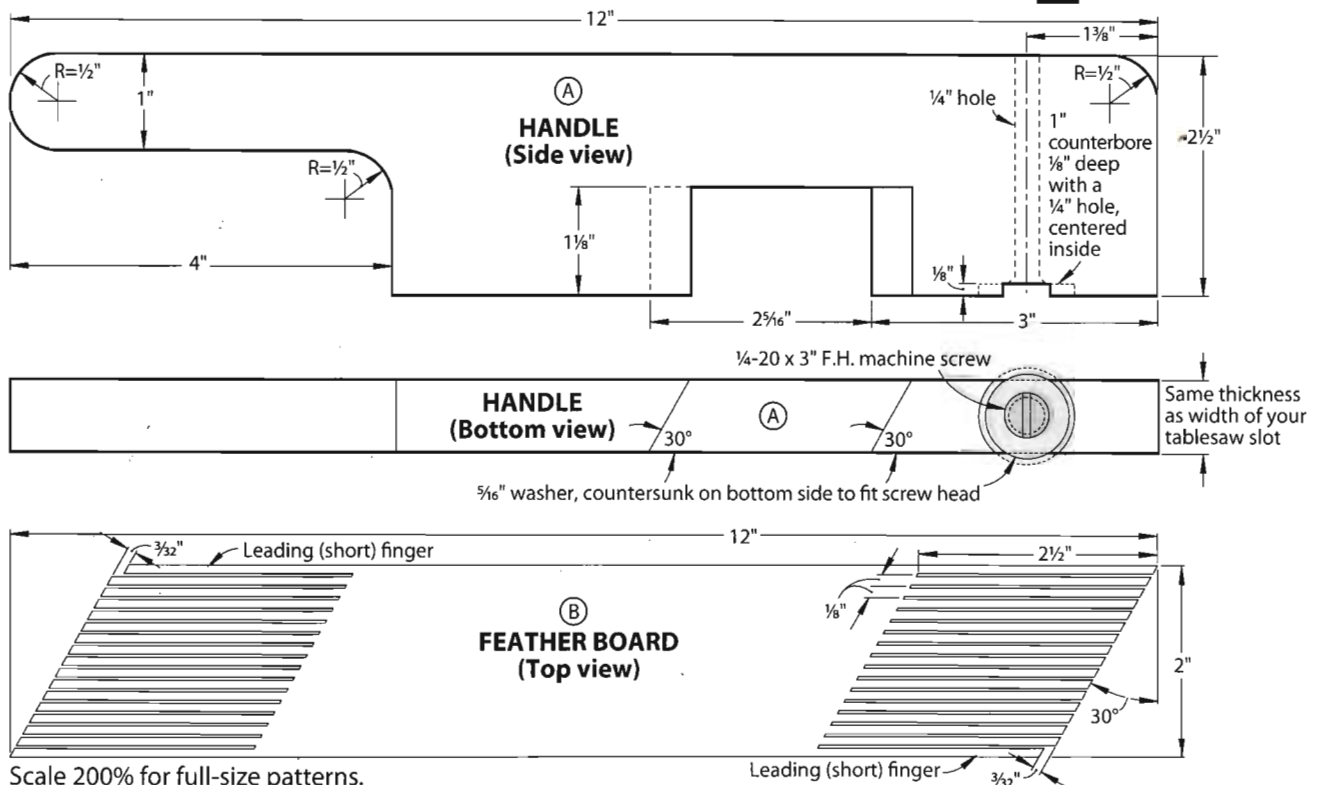

To finalize the feather board, countersink and slide a $\frac{5}{16}$ " washer onto the head of the machine screw, slide the threaded end through the handle, and fit a washer and four-arm knob onto the end. Fit part B into the angled notch and slide the bottom edge of the handle and the washer into the miter-gauge slot on your table saw, as shown on **Drawing 2a**. If the washer is too wide for your miter-gauge slot, you may

need to grind down the outside edges for a good fit.

With the saw off, slide the workpiece between the feather board and fence. Position the trailing edge of the feather board about 1" in front of the leading edge of the saw blade, as shown in the main photo *opposite*. Put too close to the blade, the feather board can pinch the kerf and cause the workpiece to bind on the blade.

Position the shorter leading finger against the workpiece, as shown in the inset photo *opposite* so the piece slides forward smoothly yet is held firmly against the fence. If pushing the workpiece between the feather board and rip fence offers too much resistance, back part B off slightly. Once in proper position, tighten the four-arm knob to secure the assembly in place.

Project design: **Vernon Lee; Scott Splerling, Sunnyvale, Calif.**

2 EXPLODED VIEW

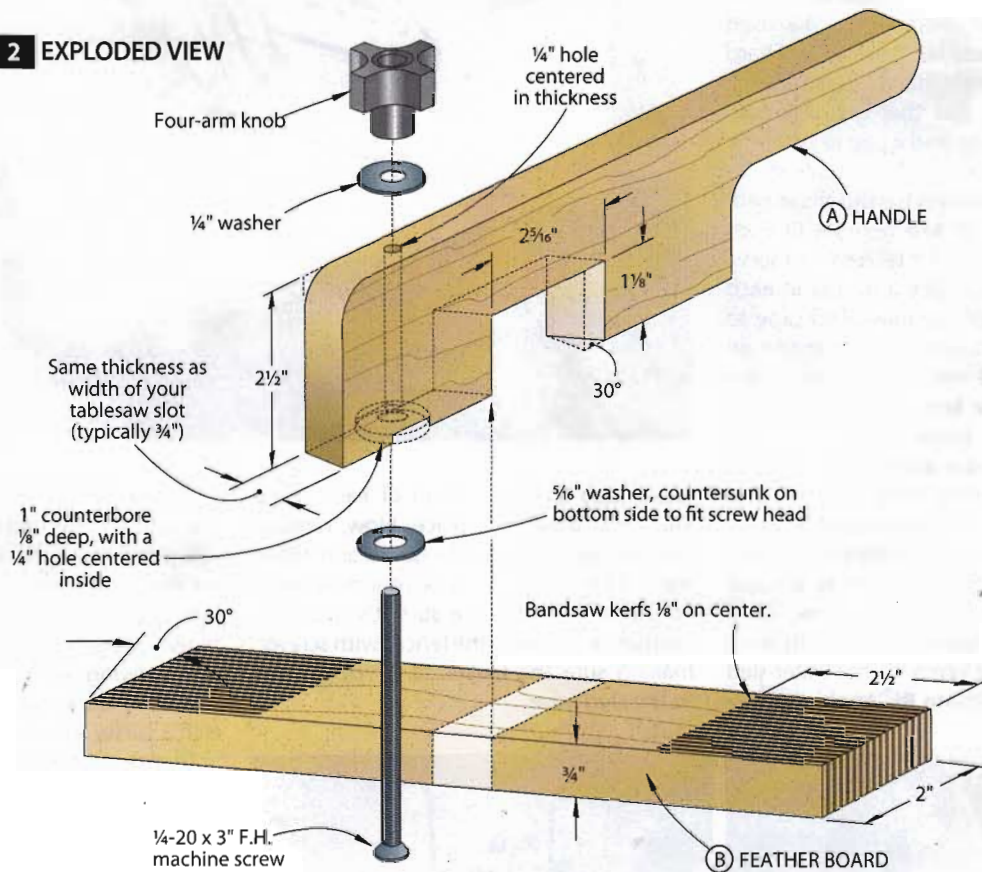

2a SECTION VIEW

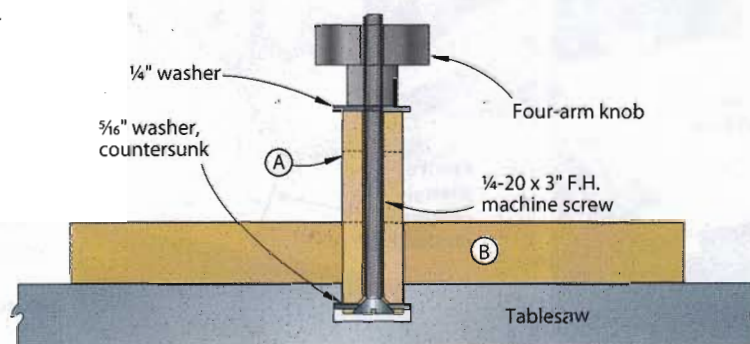

Tablesaw miter sled

Here's a great way to get on-the-money angled cuts every time.

This miter-cutting sled offers a dual-runner guidance system that rides in the miter-gauge slots of your tablesaw, and adjustable stops that ensure equal-length parts. It also features a safety channel down the middle to keep your hands away from the tablesaw blade.

To build the jig, see the drawing on the next page for the dimensions. We used Baltic birch plywood for the base and hard maple for the other parts. Refer to the photos below for tips that guarantee an exact fit on your saw and a pair of perfectly aligned miter fences.

To mount the runners to your miter sled, place two stacks of two pennies in each miter-gauge slot on your tablesaw to serve as shims [Photo A]. Place a runner in each slot and then apply double-faced tape to the top of each runner. Put two marks on the center of the sled base to define the edges of the blade kerf, and locate the rip fence to bracket those marks over the blade. Press the base against the runners, remove the assembly from the saw and permanently attach the runners with screws.

Place the sled on your tablesaw and cut a kerf about 6" long to serve as a visual guide for placing the fences. Now, cut a right triangle measuring 21½" on its long edge and clamp it firmly to the miter-sled base, as shown [Photo B]. Apply double-

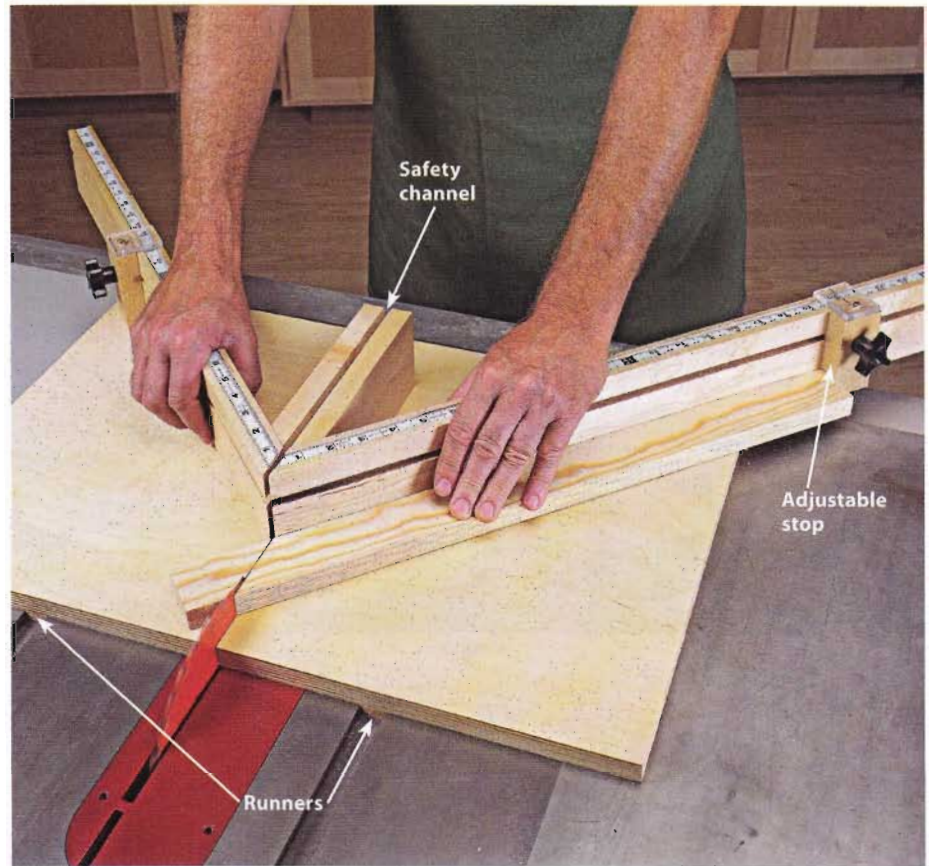

faced tape to the bottom of each fence and press them into place. Now, remove the clamps and triangle guide and make test cuts in scrap to check your new sled's accuracy. When you're sure it's dead-on, permanently attach the fences with screws, making sure the fences sit perpendicular to the sled base.

Affix self-adhesive measuring tapes into the groove atop each fence. (Any ½" tape will work, but a right-to-left reading tape for the left fence and mirror-image left-to-right tape for the right fence will be easier to use.) Make the stop blocks according to the drawing on the next page. Before attaching the acrylic to the blocks, draw or etch a cursor line down the center of each.

To make two workpieces of equal length, start by measuring and marking both ends of the first workpiece. Miter one end using the sled, then transfer the workpiece to the opposite fence. Line up the second mark with the blade, butt the stop against the already mitered end, tighten it, then make the second cut. Leave the stop in place and miter the second workpiece in the same sequence. To avoid weakening the sled base, stop your cut when the highest point of the blade passes through the fence.

Use an 80-tooth crosscut blade for smooth, ready-to-glue surfaces.

Project Design: **Brian Hahn, Avoca, Wis.**

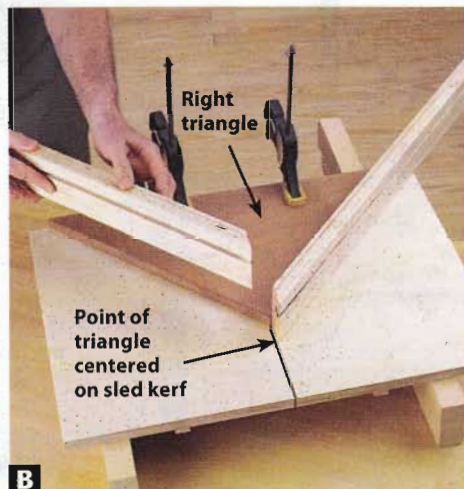
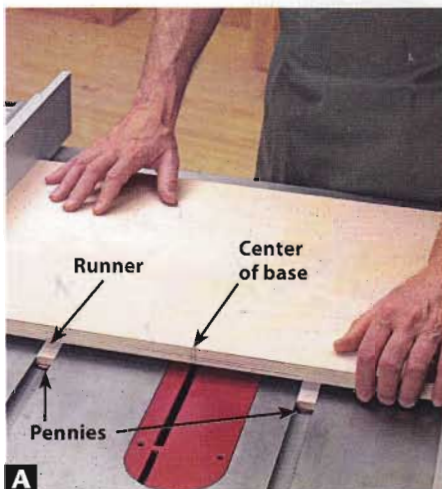

Fence-riding tablesaw stock feeder

This clever jig helps you run thin workpieces safely through your saw.

Are you looking for a safer alternative than a pushstick for ripping thin strips? Look no further. This fence-riding stock feeder provides downward pressure on the workpiece, and at the same time it keeps your hand well clear of the spinning blade.

This feeder uses a pair of subassemblies: a fence-hugging sled and the hold-down, which are held together by a $\frac{1}{4}$ " wood dowel that allows the hold-down to pivot to match stock thickness. The dimensions shown in the drawing, at right, are for a fence body that's 4" wide and $2\frac{1}{2}$ " tall, so you may need to adjust them to fit your fence. The cutouts shown in the drawings lighten the overall weight of the jig, but you can skip them if you prefer.

Assemble the parts as shown and don't forget to bevel and notch the sled parts where indicated. The bevel allows the hold-down to rotate freely. Also, cut the dowel rod $\frac{3}{4}$ " longer than the width of the assembly so you'll have space to drill holes and install cotter pins at both ends.

Project Design: **Bob Carter, Owens Cross Roads, Ala.**

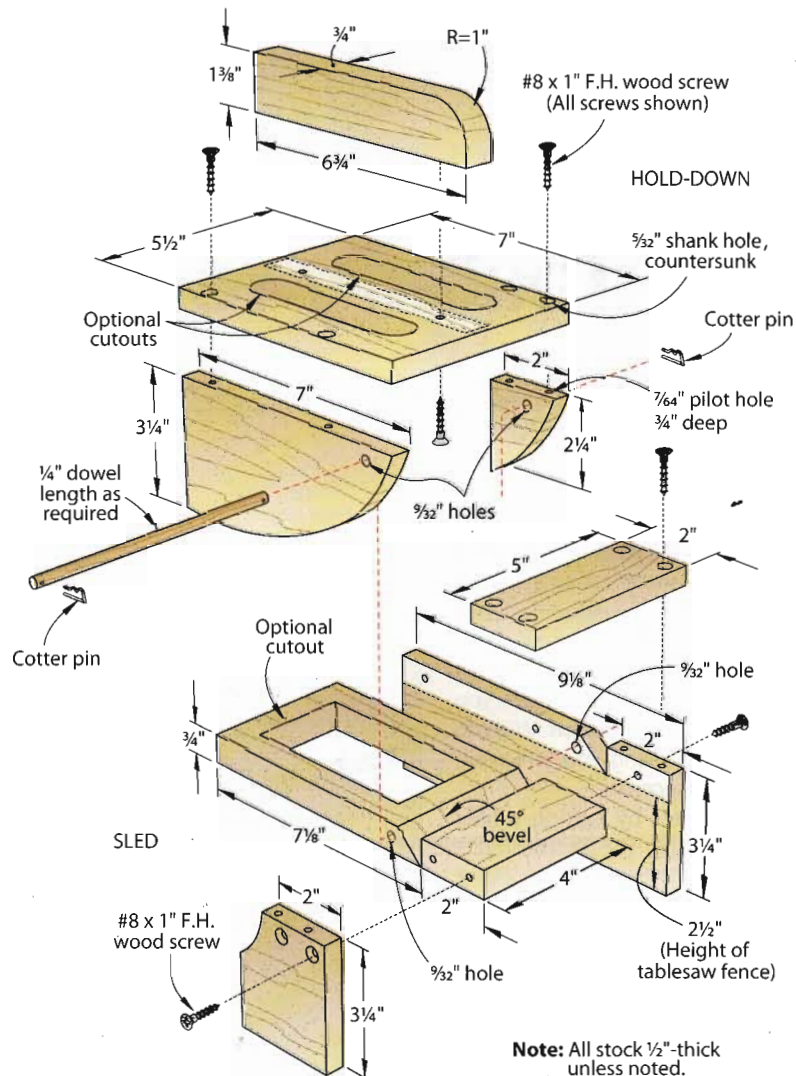
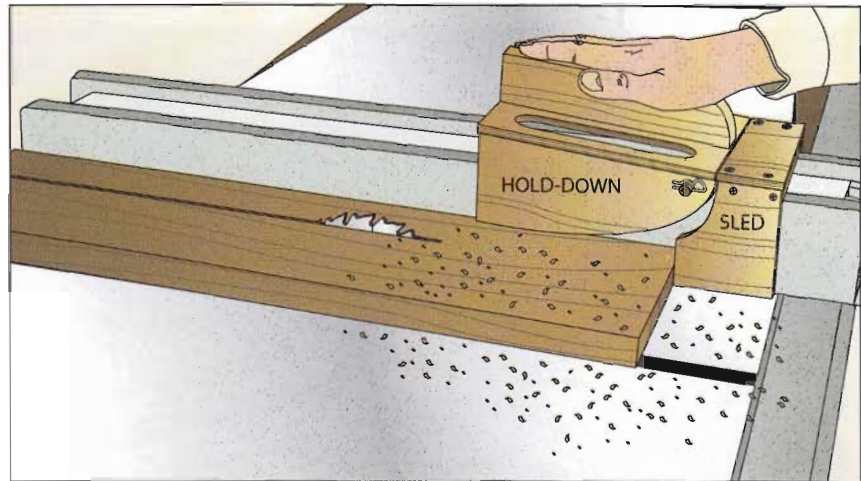

Note: All stock $\frac{1}{2}$ "-thick unless noted.

QUICK TIP: FENCE ALIGNMENT

Having trouble lining up your fence parallel with the blade or miter-gauge slot on your tablesaw? If your fence has a square or flat rear rail, here's a quick solution. Affix an adhesive-backed tape measure to the rear rail so it reads the exact same measurement at the right-hand miter slot as the measurement scale on the front of the fence. Then, set your blade parallel to the miter slot per the saw's owner's manual. Whenever you position the fence, just make sure that the face of the fence bar aligns with the same measurements on the front and back rails before locking.

—Scott Geurin, San Clemente, Calif.

Quick-and-easy height gauge

Raise your cutting accuracy to new levels.

Set the cutting depth of tablesaw blades easily using this adjustable gauge. To ensure accuracy, we outfitted it with a steel rule. See **Source** below for the parts.

Start by cutting the body to size from $\frac{3}{4}$ " maple, as shown on **Drawing 1**. Plow a $\frac{13}{32}$ "-deep groove, sized to fit your rule, in one face of the body, where shown.

Next, set your dado blade to $\frac{1}{4}$ " and cut the combined rabbet and groove in the body for the sliding bar. To do this, place the gauge body on edge (ungrooved face against the fence). Cut the rabbet/groove in three passes, with the last one at $1\frac{5}{8}$ ", where shown on **Drawing 1a**. Drill and countersink the screw hole. Then, sand and finish the body.

Use a coping saw or scrollsaw to shape the $\frac{1}{4}$ " acrylic sliding bar to the dimensions shown. Create the adjustment slot by drilling a pair of $\frac{5}{16}$ " holes where shown and cutting out the material between them. Smooth the edges of the slot and the outer edges of the bar using a fine file. Buff the outer edges if you want to make them supersmooth. Now, scribe a cursor line on the back face, where shown.

Attach the steel rule in the groove using double-faced tape. Place the bottom end of the rule $\frac{1}{4}$ " from the bottom of the body. Then, install the sliding bar.

To use the gauge, set the cursor line to the desired height. Hold the sliding bar in its groove while adjusting the gauge to keep the bar square with the base. Place the body on the tablesaw top beside the blade, as shown in the photo, then raise the blade to set the height.

Source

Hardware. Stainless steel rule no. 06K20.06 \$2.40; $1\frac{1}{2}$ " four-arm plastic knob ($\frac{1}{4}$ -20 threads) no. 00M55.30 \$2.20. Lee Valley; 800-871-8158, leevalley.com.



1a TOP VIEW

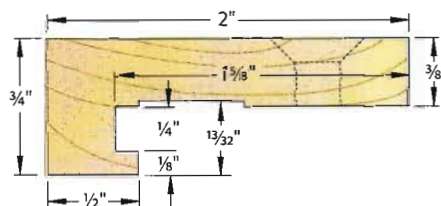

1 EXPLODED VIEW

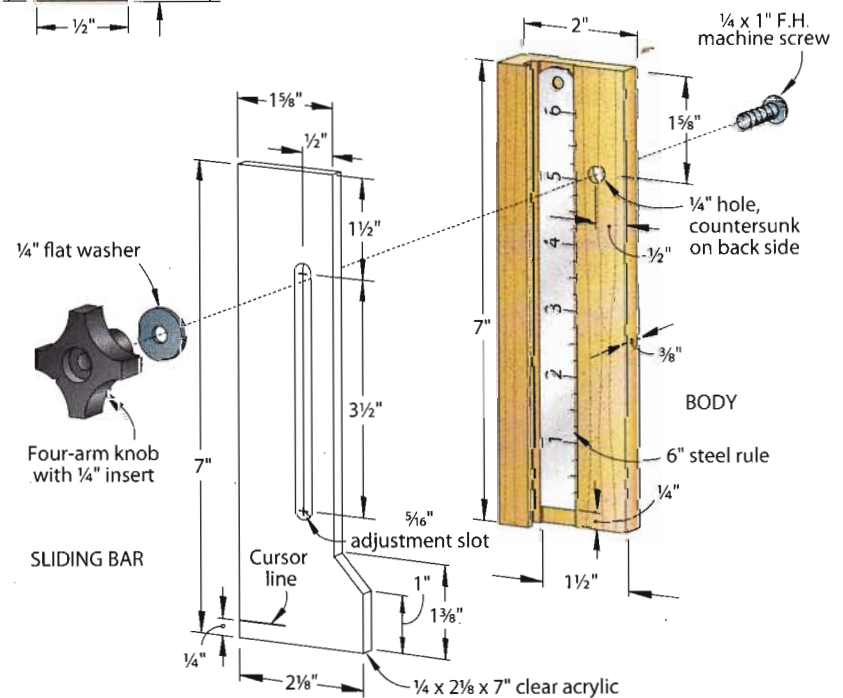

Bandsaw lumber mill

Turn firewood into free stock for small projects.

The more we work with this jig, the more we like it for turning found wood into valuable stock. Here, we'll cover the basics of building and using this jig for ripping small logs and other odd-shaped blocks of wood into short boards.

Cut the jig pieces to shape

Cut the subbase, base, fence, bolt-support block, and braces to size from $\frac{3}{4}$ " plywood [Drawings 1 and 1a]. The height of the fence will be determined by the clearance of your bandsaw blade guard to the bandsaw table. Bandsaws with riser blocks and 16" bandsaws will rip wider stock, allowing for taller fences than the clearance of a standard 14" bandsaw.

Cut the dado, drill the holes and form the slots in the pieces, where marked. See Drawing 1a for slot locations in the fence. (We intentionally offset the middle slot in the fence to the knob slot in the base to better access the middle-fence slot.) Cut the runners to size from solid stock. Rout $\frac{1}{4}$ " round-overs on the handle openings in the braces. Assemble the jig in the configuration shown using glue and screws. Add finish to the different pieces. Do not glue the runner to the base, as you have to remove it later for certain operations.

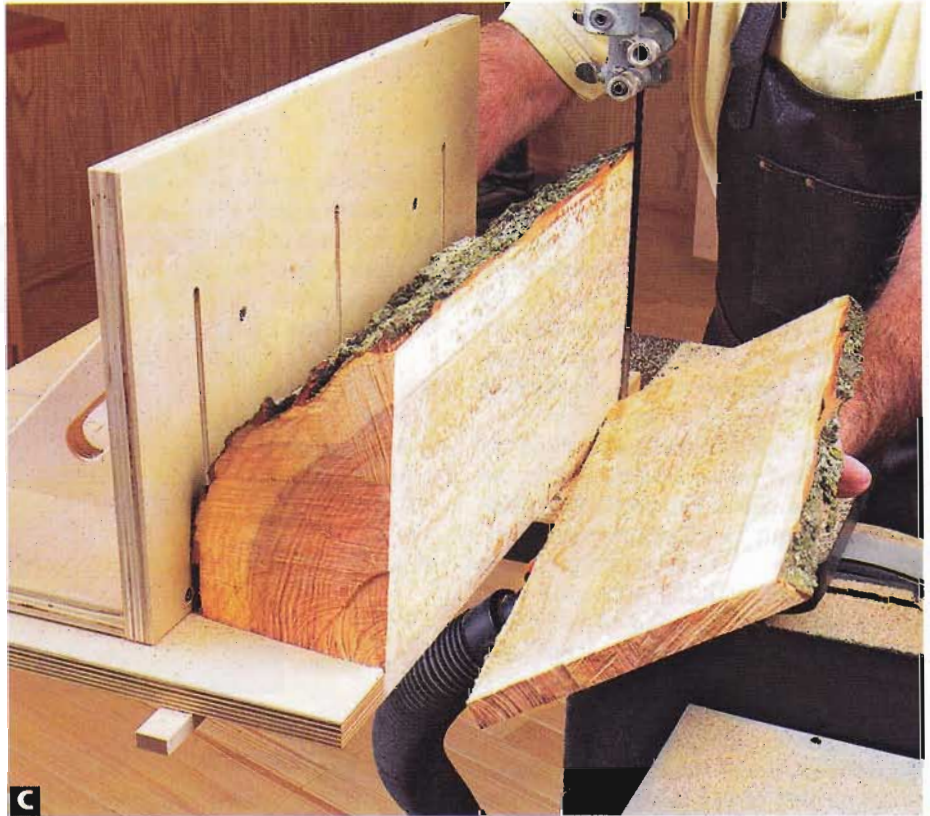

1 EXPLODED VIEW

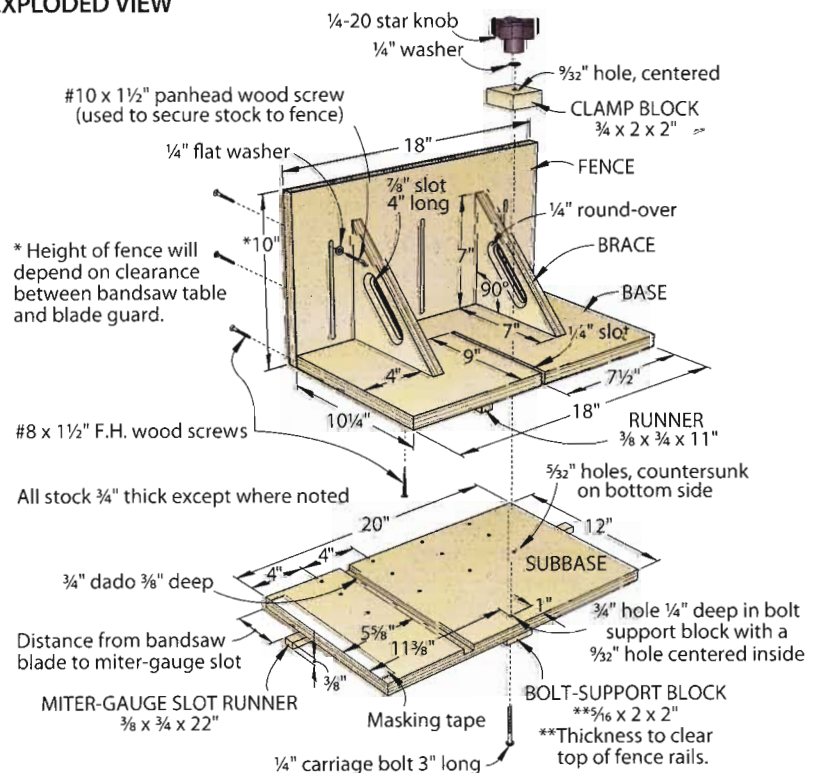

1a FENCE (Blade side shown)

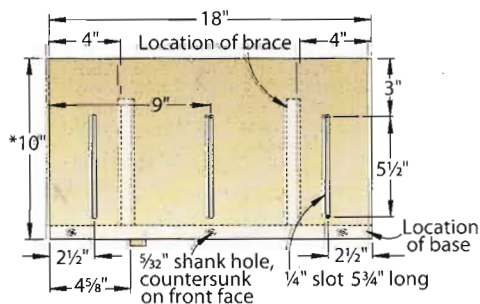

Caution: Resawing exposes large portions of the bandsaw blade, as the blade guard has to be raised just above the workpiece to allow the stock to move through the blade. When making resaw cuts, the blade is often hidden deep in the wood being cut. Always know exactly where the saw blade will exit the wood and never push the workpiece at the blade exit point when finishing a cut. Use a block of wood as a pushstick if needed.

Using the subbase as a sliding table

For log half sections and other workpieces too large to fit between the assembled jig subbase and blade guard, secure the log section or workpiece to the subbase with wood screws, making sure the screw heads are countersunk so they don't scratch the bandsaw table surface. For a stable fit against the subbase, machine the bottom surface of the workpiece as flat as possible with a hand plane, power plane, or wide jointer.

Draw a cutline on the bottom surface of the workpiece of where you want to make the first bandsaw cut. Position the subbase upside down on the workpiece and line up the edge of the subbase with the marked cutline. For stability, the subbase should cover at least half of the workpiece in order to keep the workpiece from tilting when being cut on the bandsaw. Screw the workpiece to the subbase.

Position the jig on the bandsaw table with the miter-gauge slot runner in the miter-gauge groove and make the first cut [Photo A]. Do not use this process for a completely round piece of wood (log or branch). For round stock, use the subbase with the fence for maximum stability.

Combine the subbase and base/fence for max support

Secure the base/fence assembly on the subbase with the carriage bolt and knob, and screw the workpiece to the fence in at least two places for a secure mount. Some workpieces [Photo B] may require shimming to keep them perfectly stable when cutting. With the workpiece screwed to the fence, position the workpiece so it overhangs the subbase by about 1" to allow for drying and planing. Tighten the knob to secure the base to the subbase. For long stock (anything over about 18"), we recommend using a helper or an infeed and outfeed table to keep the jig flat on the bandsaw table when starting and finishing the cut.

Make the first ripping cut as in Photo C on *opposite* page. The handle openings in the braces allow you to push the stock through the blade while keeping your hands clear of the cutting blade. Turn the saw off, and back the jig and stock past the blade once it has stopped moving. Using a combination square, mark an increment line on masking tape [Photo D]. Allow about $1/8$ " extra for the kerf and any possible follow-up machining (sanding or planing) you may want to do to the resawn stock later. For example, if you need $1/2$ " finished stock, mark $5/8$ " increments.

Loosen the knob and reposition the fence/base assembly on the subbase, aligning the outside edge of the fence with the next increment mark on the masking tape. The runner on the bottom of the base allows you to move the base/fence parallel to the subbase and bandsaw blade, to allow for consistent width from the front to the back of the piece being cut.

Tighten the knob and make the next cut. Determine exactly how far the screws through the fence enter the workpiece to avoid cutting into the screws with the

blade. Our $1\frac{1}{2}$ " screws protrude into the workpiece $3/4$ ", so we never cut closer than $1\frac{1}{4}$ " from the fence, allowing us a full $1/2$ " of clearance between the blade and ends of the screws.

Using the fence for standard resawing operations

Remove the base/fence from the subbase. Place the base/fence assembly between the bandsaw column and blade [Photo E]. Adjust the position of the fence to the blade for the desired thickness to be cut. Clamp the base/fence to the bandsaw table keeping the fence parallel to the miter-gauge slot. It's important that the workpiece have a flat bottom to ride on the bandsaw table.

Project Design: **Brian Hahn, Avoca, Wis.**

Watch a 5-minute video of this bandsaw jig in action at:
woodmagazine.com/resawvideo

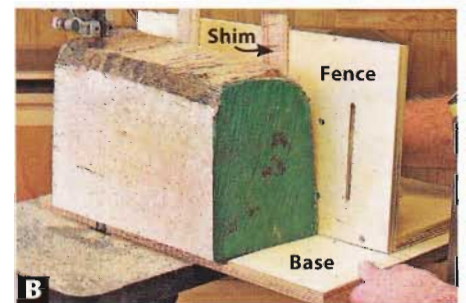
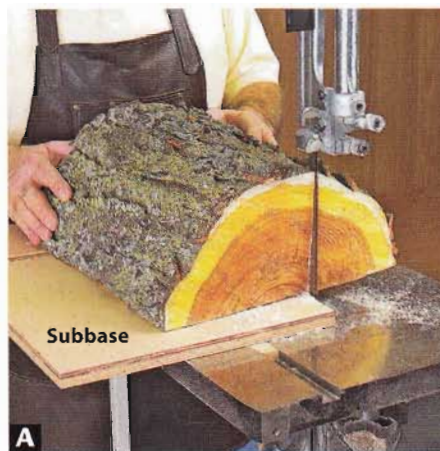

Bandsaw circle-cutting jig

What goes around comes around with this sawing aide.

Making perfect circular workpieces is easy with this handy helper. The jig consists of a piece of $\frac{1}{2}$ " plywood with a dovetail slot glued into a centered dado. Into the dovetailed slot slides a matching key with a dowel pivot pin at one end, as shown in the drawing.

To use the jig, determine the radius of the circle you want. Then, with the jig clamped to the bandsaw table, move the dovetail key until the distance between the right-hand tooth of the blade and the center of the pivot pin equals that radius. Clamp a stopblock on the key at the end of the dovetail slot, as shown at *right*. Center a $\frac{1}{4}$ " hole on the bottom of the workpiece. Slide the key back and fit the workpiece onto the pivot pin. Turn on the saw and slide the dovetail key and workpiece toward the blade. Rotate the workpiece clockwise into the blade, applying slight side and forward pressure until the stopblock abuts the end of the dovetail slot. At this point, you'll begin cutting a perfectly round circle, with the side and forward pressure keeping the dovetail key in place for the duration of the cut.

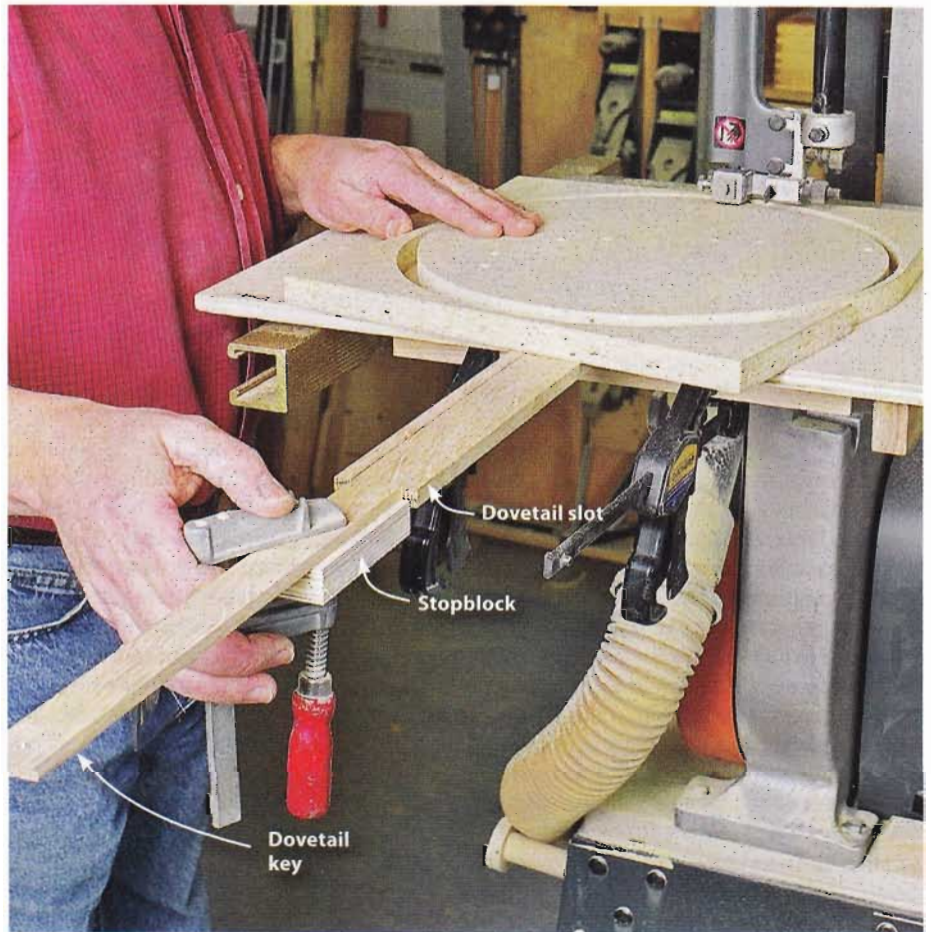

Project Design: **Michael Fortune, Lakefield, Ont.**

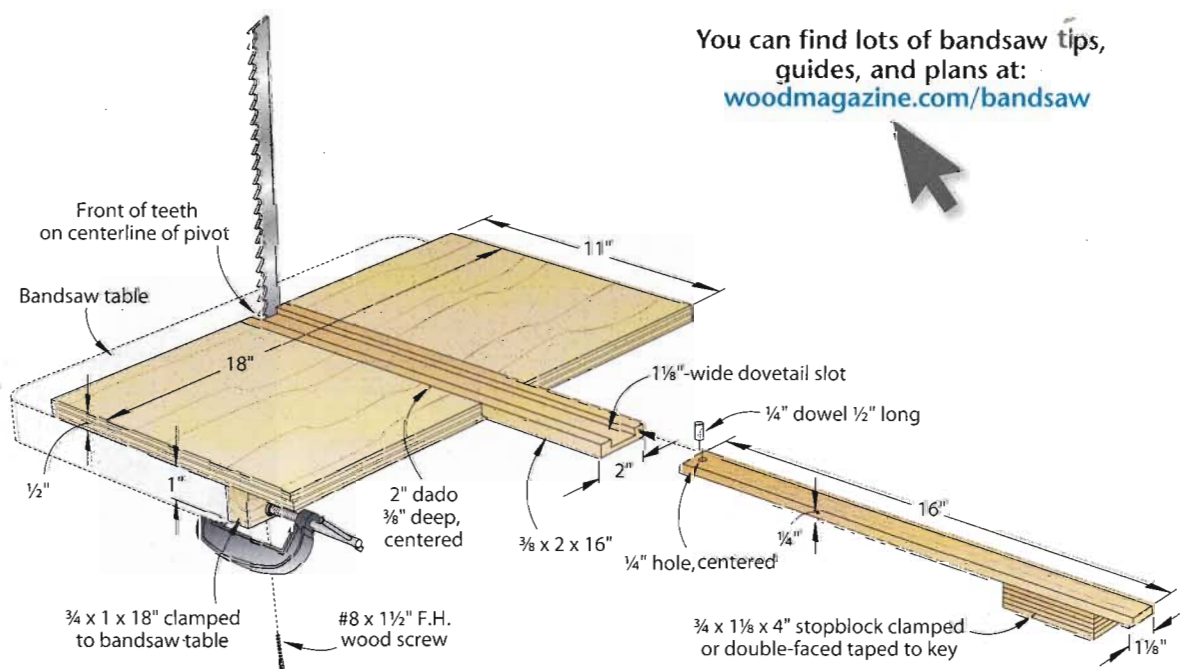

Exact-width dado jig

Adjustability is the key for a perfect cut every time.

Here's a jig for routing bookcase- or cabinet-side dados that exactly match the thickness of your shelf stock. Better yet, no special bits are needed. Just use an ordinary straight bit and a guide bushing. (We used a 1" guide bushing and a 1/2" straight bit.) To start, cut a 3/8" rabbet 3/8" deep along the inside edge of both guide rails (A). Then, complete the jig, as shown in **Drawing 1**. To customize the rails for a different bushing and bit, install them in your router and trim the protruding lip of the rabbet in the guide rails, as shown in the Dadoing Detail in **Drawing 1a**. The remaining lip will now match your bushing/bit combo.

To adjust the jig for the exact width of your shelf stock, slip the jig over the shelf stock, as shown in the Exploded View. Pull the guide rails (A) tightly against the stock and tighten the wing nuts. Slip the jig off the stock and clamp the jig onto the piece being dadoed, centering the opening between the rails (A) over the marked dado on the side panel. Adjust the depth of cut with your router sitting on top of the rails. Start the router and make one pass with the guide bushing riding against one of the rabbeted rails. Make a second pass, riding the bushing against the opposite rabbeted rail.

Project Design: **Wayne Kovi, Wallingford, Conn.**

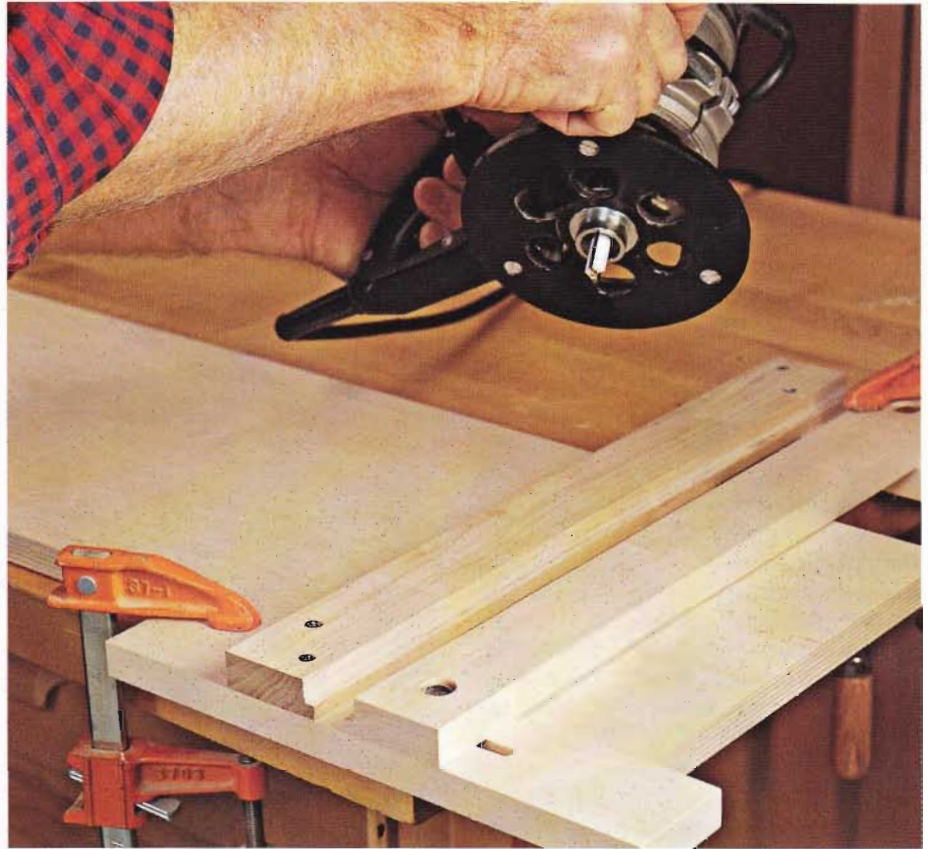

1a DADOING DETAIL

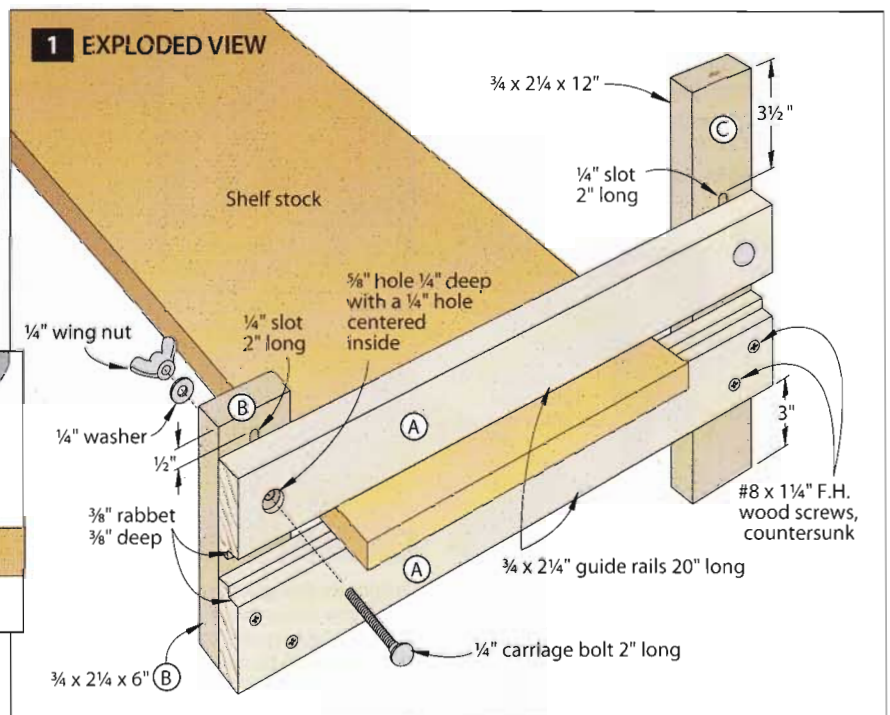
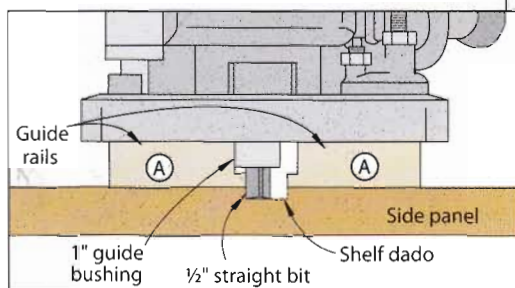

Multihole doweling jig

Speed dowel tasks with accuracy and high visibility.

Dowels provide extra mechanical strength when joining end to edge grain, and dowel joints are faster to make than hand-cut dovetails. Dowel joints are pretty much fool-proof, and with this jig you can take the joint further and have the dowels come through the other side.

In addition to accurately positioning dowels for most doweling joints (the jig comes in particularly useful for face-frame joinery), the jig excels at tasks such as aligning shelf-support pins [Photo A].

The 2" counterbored slots in the 3/8"-thick plastic jig make the jig versatile. The adjustable, removable stop will help you precisely position face stock.

Follow **Drawings 1** and **1a** to build the jig. Lay out and drill the 5/8" holes as accurately as possible in the plastic; a drill press for this step speeds assembly.

Using the jig

With a guide bushing [Photo B] in your router, dowel holes always line up regardless of how accurately you spaced the 5/8" holes for your jig. For this type of plunge routing, use upcut spiral bits, like the one shown below.

To position the jig and router to make identically spaced dowel holes in face-frame stiles and rails; see **Drawings 2** and **3**.

Project Design: **Patrick Spielman, Fish Creek, Wis.**

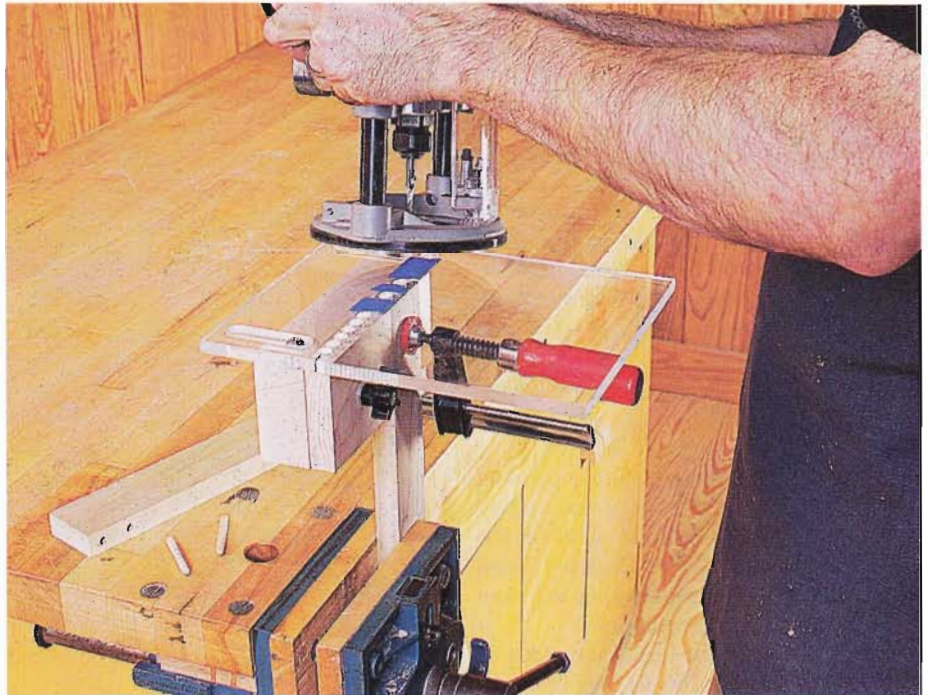

The doweling jig makes quick work of doweling tasks, including the face-frame joinery (end to edge grain) above. The 5/8" guide-bushing hole is compatible with 1/4", 5/16", or 3/8" dowel pins. The positioning block ensures quick, accurate alignment of the stock. **Drawings 2** and **3** opposite show routing dowel-pin holes in the rail and stile.

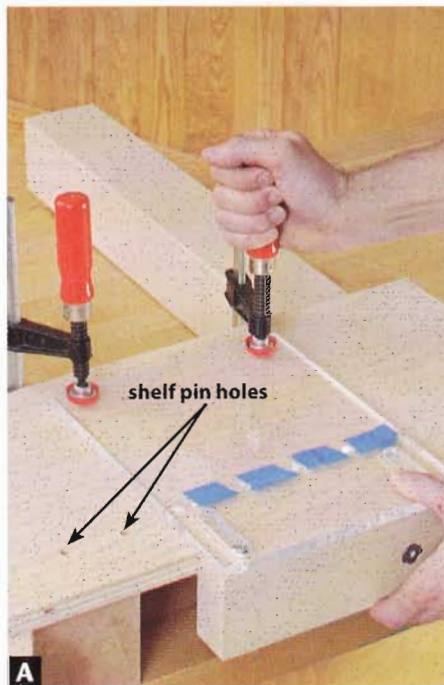

Originally designed for doweling, this jig also helps you make evenly spaced holes for shelf pins. To avoid goofs, tape over holes you won't use and remove the positioning block. (Spacing of 1 1/4"-2" between holes works well in most shelf-pin applications.)



Two-piece guide bushings easily attach to your router's base and offer exacting accuracy when lining up holes.

1 EXPLODED VIEW

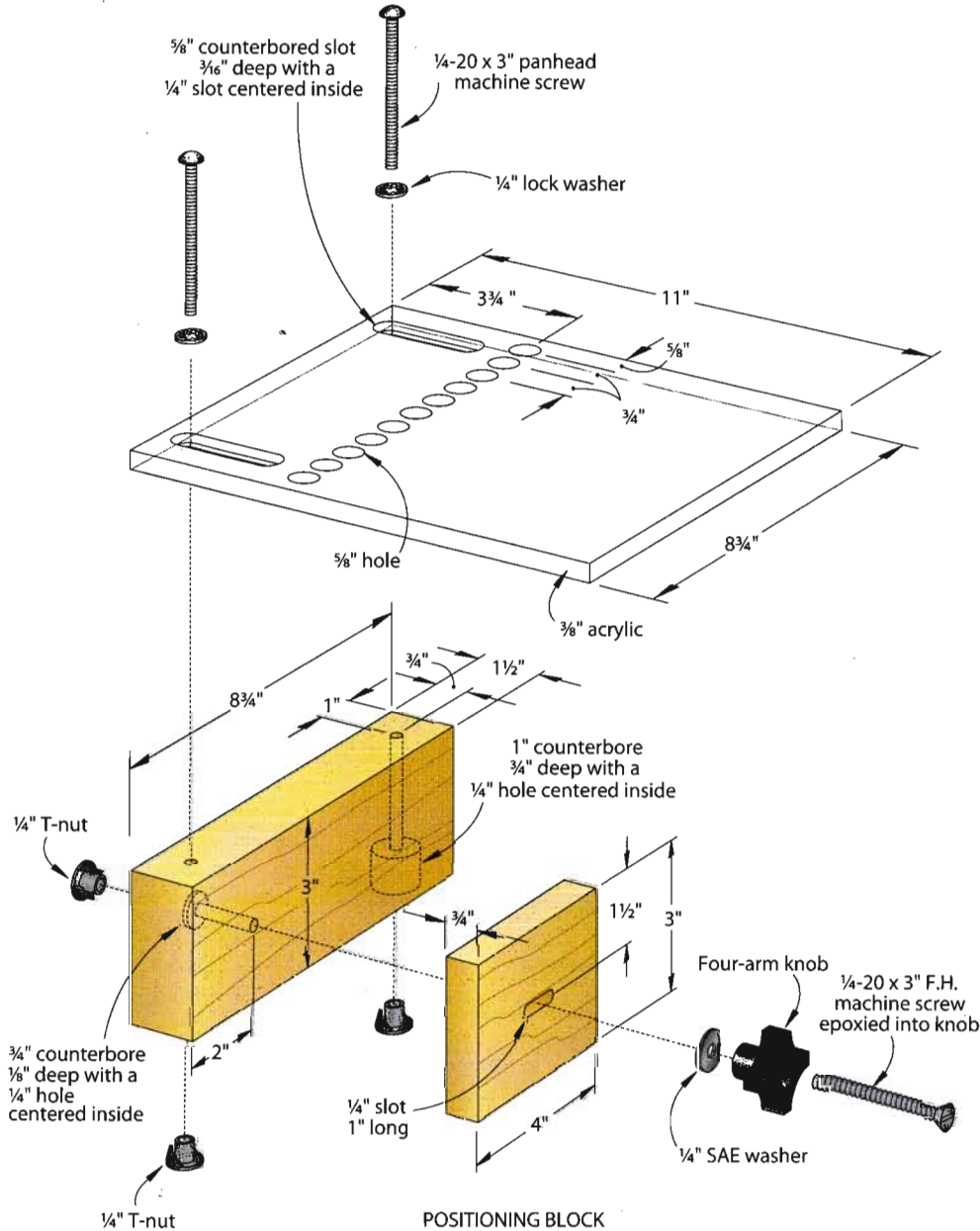

1a SLOT DETAIL

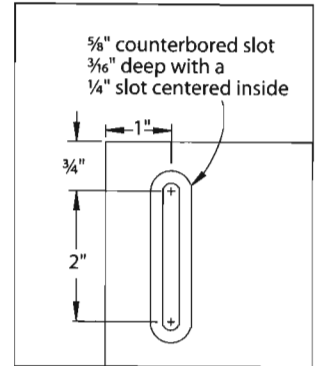

2 CUTTING HOLES ON STILE EDGES

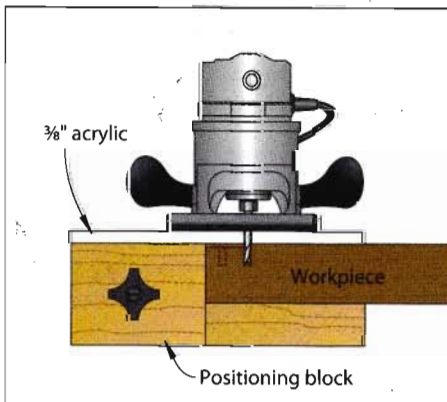

3 CUTTING HOLES ON RAIL ENDS

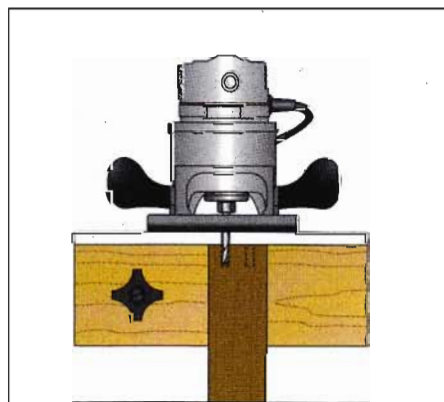

Right-angle router-table push pad

Cleanly cut 90° ends with precision and ease.

Not only does this simple guide keep stock perfectly square to the router fence, it also supports the back edge of the routed stock to minimize tear-out. Plus, it keeps your hands safely away from the spinning bit.

To build it, cut the pieces to the sizes and shapes noted on the drawing. Cut several extra supports so you can replace them as the inside end gets routed away. For a comfortable grip, rout the edges of the handle with a 1/4" round-over bit.

Screw but do not glue the support to the base. Take special care to place the attachment screws for the support so that they will never come into contact with your larger bits. Then, screw the handle to the base. Sufficiently countersink the screws securing the handle to the base so they don't scratch or catch on the top of your router table.

Project Design: **Tom Clark, Sarasota, Fla.**

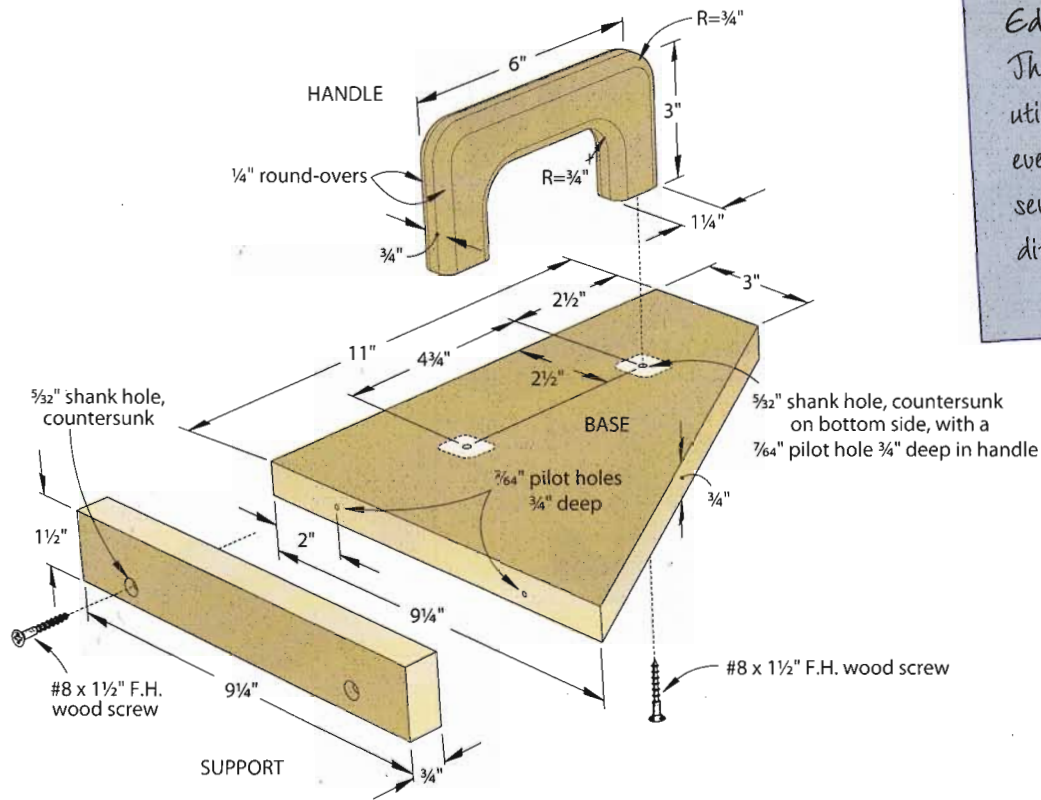

Editor's Choice
This simple and perfectly utilitarian jig belongs on every router table. I keep several of these on hand for different bit profiles.

A.J.H.

Router-table cope-cutting sled

Rout rail ends safely and precisely with this easy-to-make accessory.

A rock-solid support system helps you rout rail ends that tightly fit mating stiles. The large base, dado, and hold-downs designed into this sled accomplish just that, while the handle and dowel keep your hands safely away from the spinning bit.

This sled shines at production-oriented work—cutting lots of rails on a regular basis, for example. For more basic day-to-day tasks requiring 90° routing, consider the push pad on the *previous page*. Better yet, make both for a perfect routing team.

Build this sled by cutting the parts to the sizes noted on the drawing. Make several extra sacrificial backer strips. The backers create zero-clearance supports for cleaner cuts and can be easily replaced after becoming too chewed up.

Glue two pieces of 1/2x7 1/2x17" plywood together face-to-face for the base. Cut a 3/4"-deep dado 4" wide in the 1"-thick base. Create the handle and rout 3/4" round-overs along the handle edges except for the bottom. Screw the handle, dowel, and toggle clamps to the base, making sure the screwheads are countersunk so they won't rub against the router top.

To cope the end of a rail using the sled, raise the bit 1/4" higher than if you were cutting the rail directly on the router table-top to accommodate the height of the sled base. Use the toggle clamps to secure a scrap piece of stock the same thickness as your rails firmly against the router-table fence and backer strip with the toggle clamps. Turn on the router and ease the sled and workpiece into the bit. Just after completing the cut in the rail end where shown in the photo, slide the sled and test piece backward. Doing this prevents destruction of the sled's trailing inside edge. Check the fit of the joint against your previously routed stiles, and adjust the height of the bit as necessary before cutting your rails.

Project Design: **Rod Cox, St. Paul, Iowa**

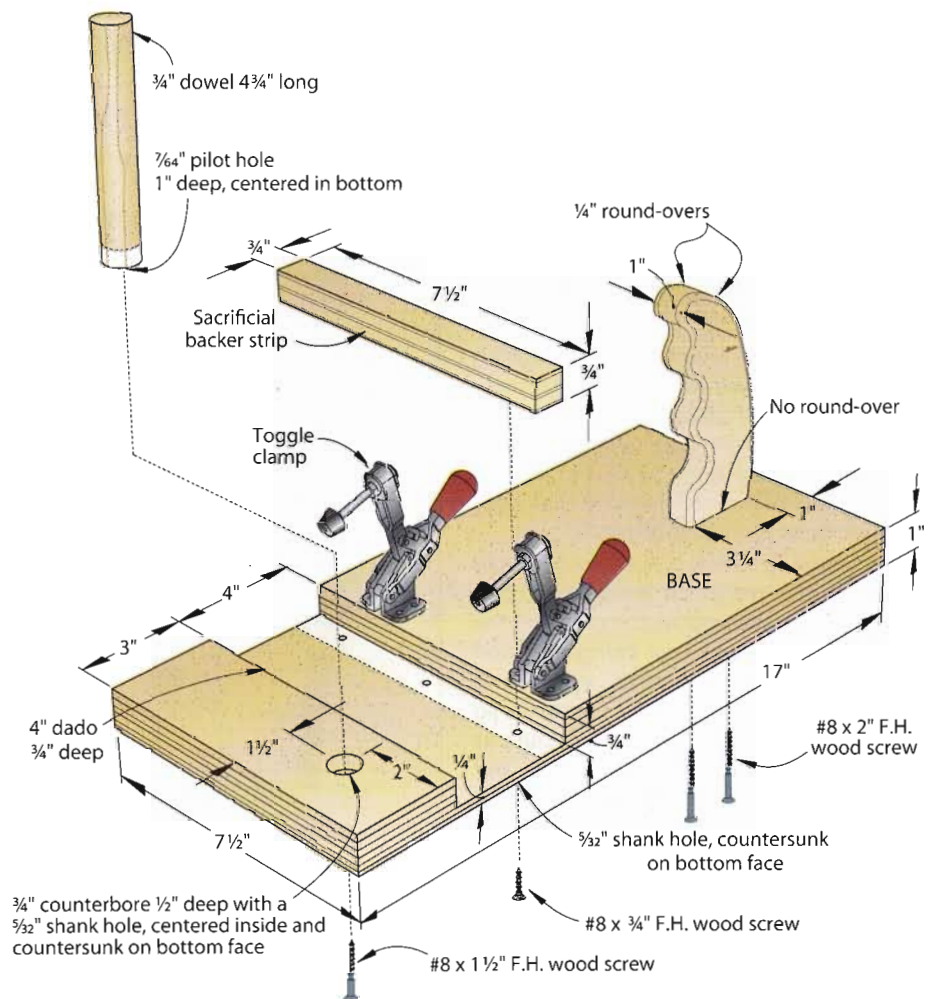
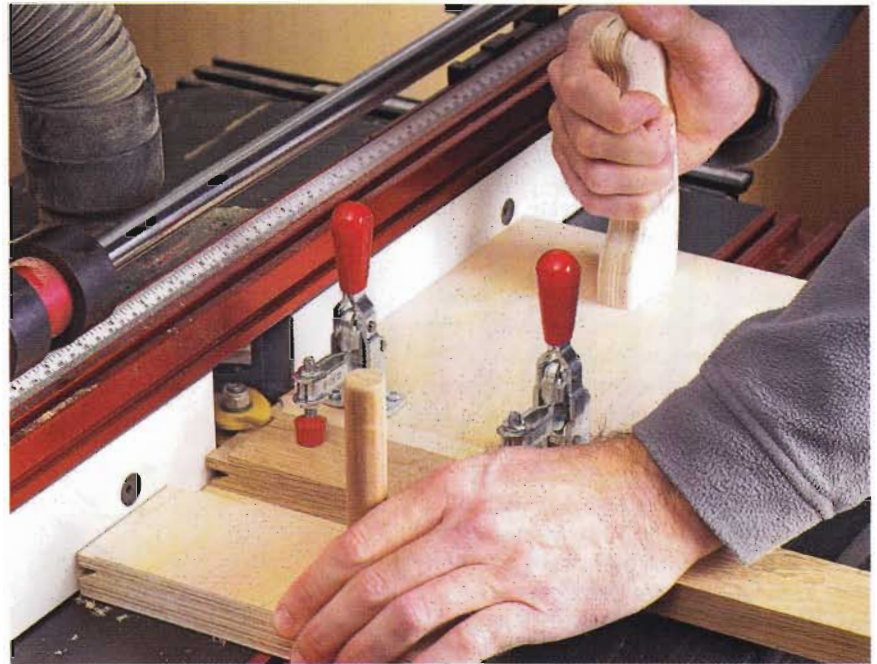

Router-table spline-cutting jig

Beef up picture frames quickly and easily.

Adding splines to mitered picture frames strengthens the joints, and the easiest way to create them on your router table is with a dedicated sled.

Build the sled from $\frac{1}{4}$ " hardboard, using $\frac{3}{4}$ " plywood or medium-density fiberboard (MDF) for the stops, as shown in the drawing. Measure carefully to ensure a 90° angle, and attach the stops with glue, or screws counterbored from underneath. To cut splines, install a $\frac{1}{8}$ " slot cutter in your router table centered on the mitered corner. Adjust the fence flush with the bit's bearing. Then, holding the frame in the sled and tight against both stops, rout the slots in all four corners [Photo A].

Cut hardwood spline blanks in 3" lengths. Glue and insert the splines into the frame slots. After the glue dries, trim the excess [Photo B]. Then, sand the splines flush.

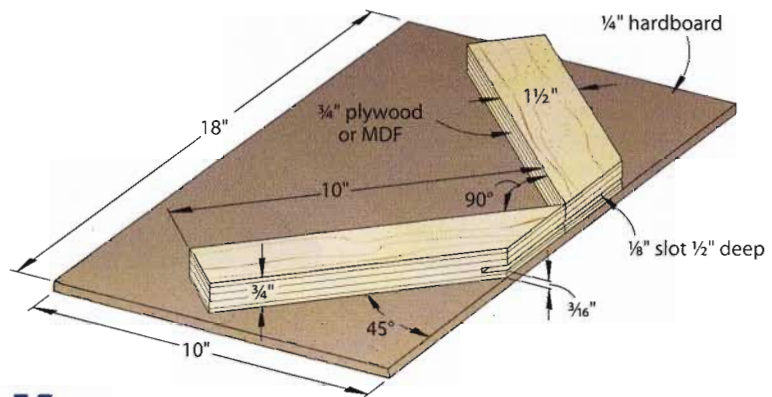
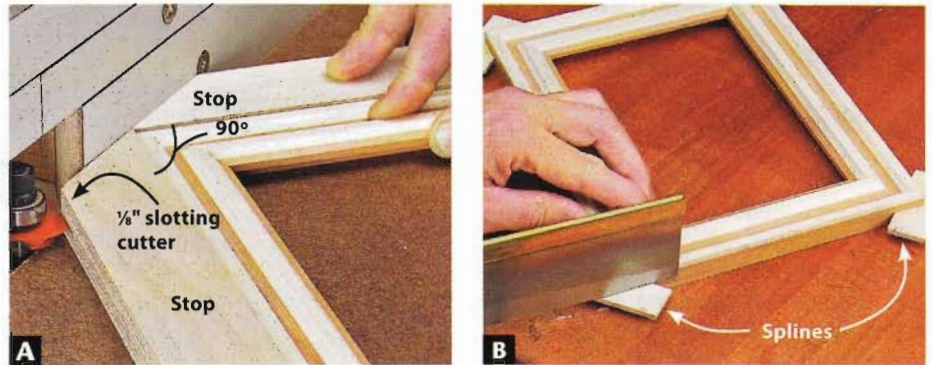

Shelf-pin drilling jig

Here's some help with holes.

Many commercial jigs for drilling shelf pins are limited with respect to hole sizes and spacing. But it's not difficult to make your own using scrap hardwood, hex nuts with an internal thread diameter slightly smaller than your desired holes, and a bit of epoxy.

Make the jig shown at right, counterbore holes in the top deep enough for two stacked nuts, then epoxy the nuts into the holes. Let the epoxy cure completely and drill through the nut threads, epoxy, and wood with the desired bit size. Clamp the jig to a workpiece and use the hex nuts as guides to drill your shelf holes, moving and re-clamping the jig as needed until you've drilled all your holes. You can drill hundreds of holes before the nuts wear out, and when they do, you can cheaply replace them.

Project Design: **Frank Penicka, Mount Pearl, Newfoundland**

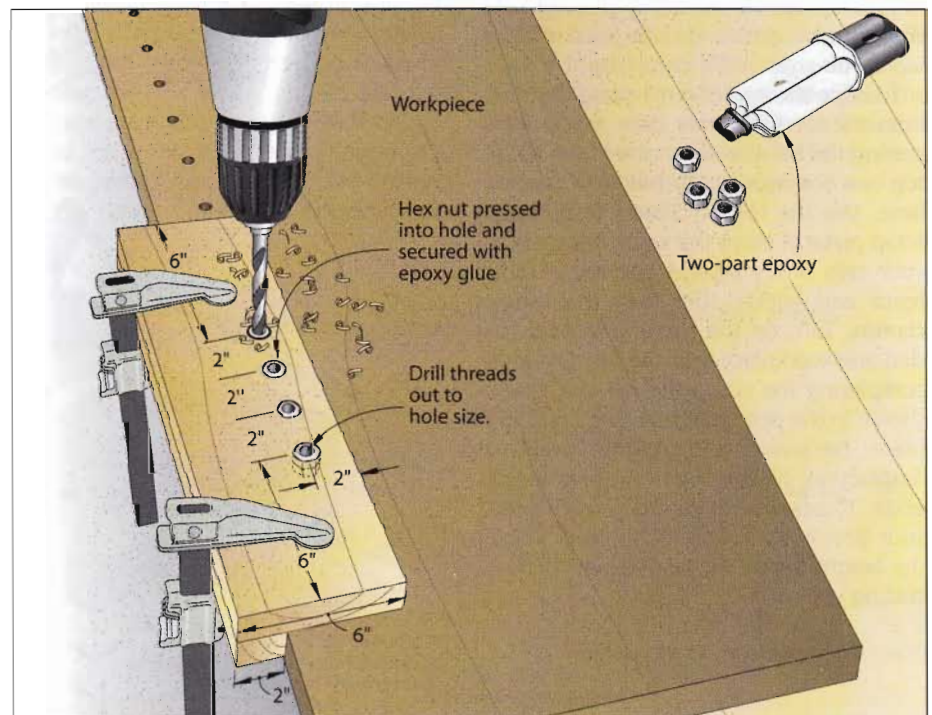

Vertical hole-boring guide

Bore clean, 90° holes in a benchtop—or any surface a drill press can't reach.

Round bench dogs, like the ones in the workbench at right, install very easily. Just bore $\frac{3}{4}$ " holes, chamfer the edges and you're done. For bench dogs to work properly, though, the holes must be perpendicular to the benchtop surface. You could wrestle the top onto your drill-press table, support it with outfeed stands and bore the outside rows of holes. But what about the inside rows? They're beyond the reach of most drill presses. With just a scrap of hardwood and a $\frac{3}{4}$ " brad-point drill bit, you can avoid the hassle and drill dead-on 90° holes anywhere.

First, cut hardwood stock to the width and length shown on the drawing. (We used a scrap of $1\frac{3}{4}$ "-thick solid stock, but a blank laminated from thinner stock also does the trick.) Next, bore a centered $\frac{3}{4}$ " hole with your drill press and then bevel the corner at 45°. The $2\frac{1}{2}$ " width of the guide keeps the bit perpendicular to the benchtop and provides enough bit travel to bore all the way through the benchtop. At 15" long, the guide extends

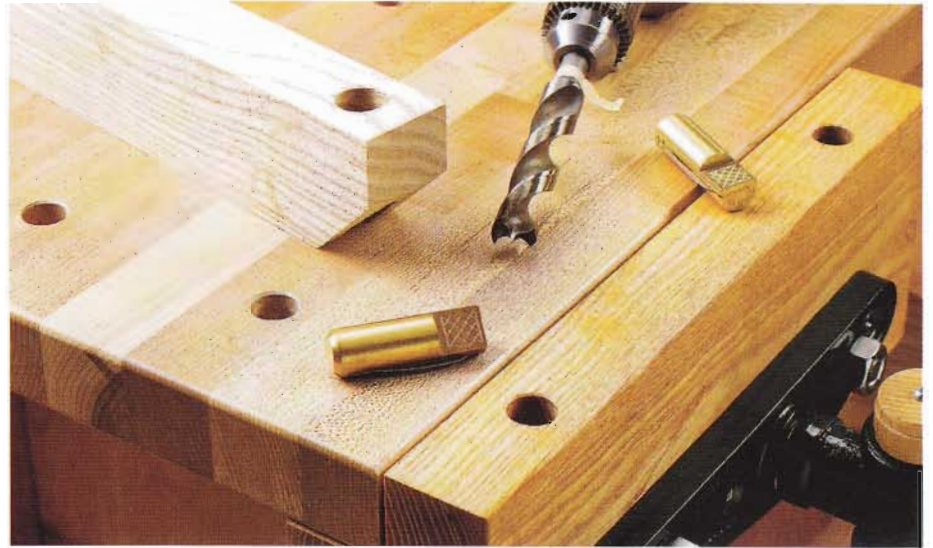

to the benchtop edge for clamping when boring an inside hole. The 45° cut exposes the bit's tip, and the marked hole centers for easy alignment and chip clearance.

To use the guide, apply masking tape to the benchtop and lay out the hole centers on the tape. Then bore holes through the top, following the five steps shown [Photo A]. To bore bench-dog holes in the edge, lay out the hole centers and follow the four steps shown [Photo B].

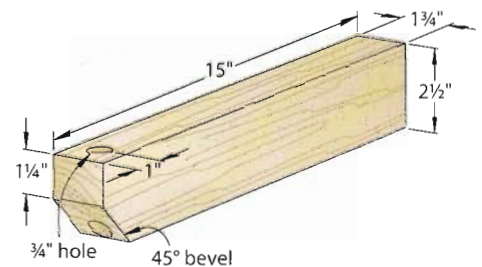

BORING HOLES THROUGH A TOP

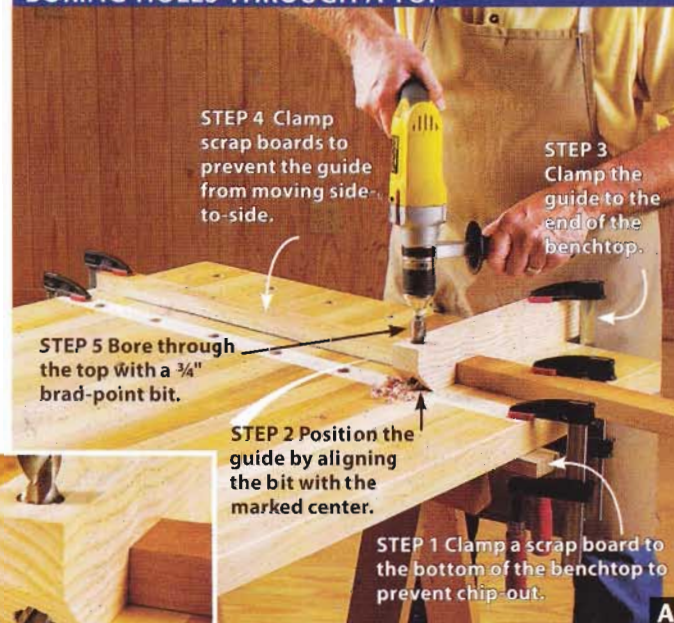

BORING HOLES IN AN EDGE



Pen-blank drilling jig

Simple, but efficient, this holder adds precision while cutting down time.

A drill press plays a major role in pen-making but is effective only if you hold the blank securely and squarely while drilling. Made from any available shop scrap, this jig with its integral clamping fence promises perfect results every time. Construct the jig from plywood, solid wood, or medium-density fiberboard (MDF) as shown in the drawing. Measure the angle of the support fence carefully and attach it to the base with countersunk screws from underneath. Extra holes drilled into the top of the fence store pen-blank drill bits when not in use. To use, put the pen blank in place and hold it tight with a spring clamp. Center the bit over the blank and clamp the jig to the drill-press table.

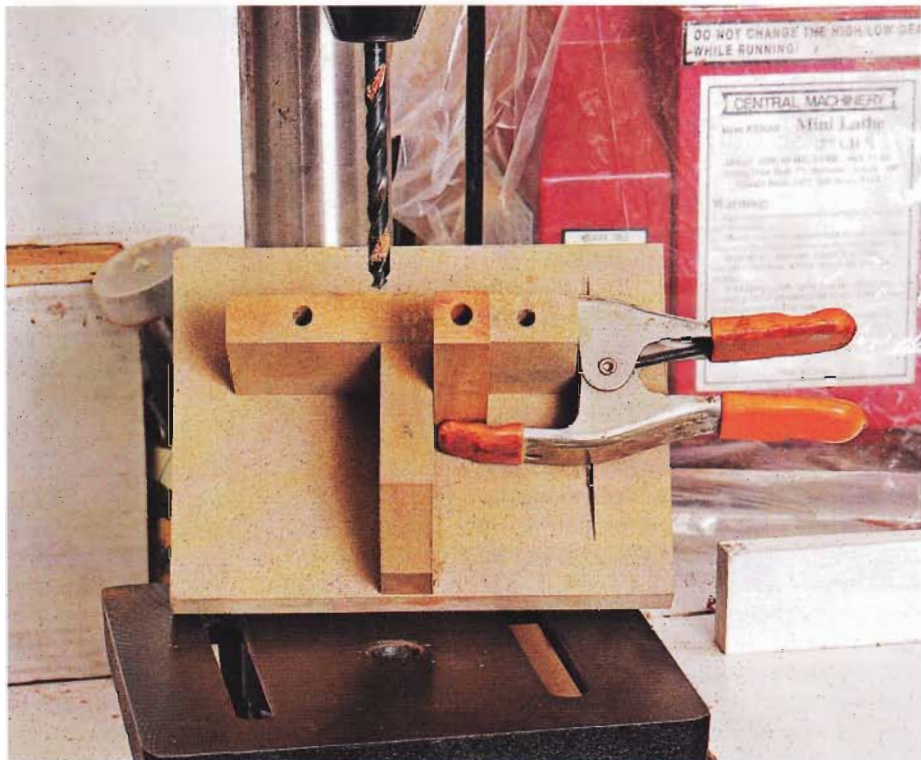

Project Design: **Erik Jorgensen, Chesapeake, Va.**

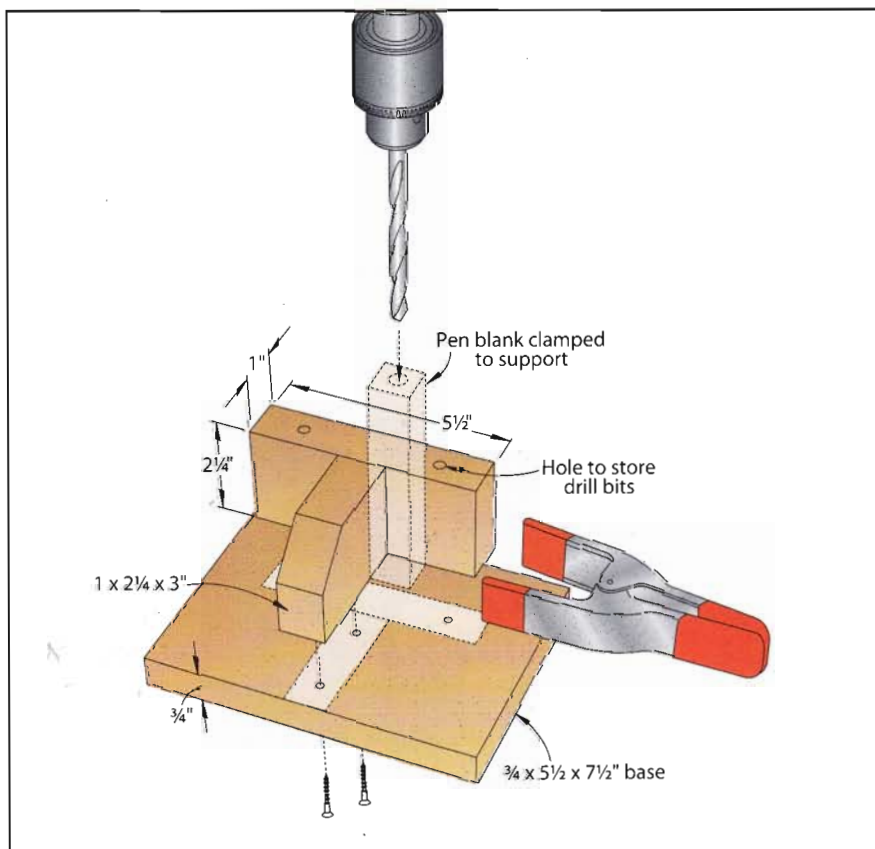

QUICK TIP: A LEVEL DRILL PRESS

This drilling jig can ensure a perfect 90° hole in your pen blanks. However, because the jig registers to the table on your drill press, it can't do its job if the table isn't perpendicular to the drill bit. Instead of using a square to true up the table, a short length of coat-hanger wire will do the job quickly and accurately. Cut a length of wire approximately 6" long, and bend it at right angles in opposite directions about 1" from each end. Don't worry if your angles aren't exactly 90°. Chuck one end into the drill and tighten while the angle on the other end points down at the table. Now raise the table so it touches the wire. Slowly rotate the drill chuck 180° by hand so you can detect any high or low spots on the table and adjust accordingly.

—John Clark, Cuddebackville, N.Y.



✓Yes



✓Yes



✓Yes



✓Yes



✓Yes



✓Yes



xNo



✓Yes



✓Yes

- ✓ Everyday Low Prices
- ✓ Easy To Use Website
- ✓ Huge Selection
- ✓ Fast Shipping

RA
ROCKAUTO.COM
 ALL THE PARTS YOUR CAR WILL EVER NEED

Dowel chamfering jig

Create precise chamfers with this accessory for your disc sander.

When used for alignment purposes, chamfered dowels insert more easily. The chamfered ends also create glue space for stronger dowel joints. (Giving glue someplace to go also cuts down on squeeze-out.)

To quickly create your own consistently chamfered dowels, build the jig shown. We used $\frac{1}{4}$ " plywood for the base and $\frac{3}{4}$ " plywood for the two 45° guides. The key is that the right-hand guide is movable to widen or narrow the gap between guides, allowing you to increase or decrease the size of the sanded chamfer as needed. We screwed the left-hand guide in place, and then secured the right-hand guide with double-faced tape.

To use the jig, simply clamp it to your disc-sander table so the inside edge of the jig is next to but not touching the sanding disc. Start the sander, slide the dowel along the left-hand guide, and rotate the end of the dowel clockwise against the disc. The right-hand guide acts as a stop to prevent you from sanding too large a chamfer. If the chamfered end isn't sanding enough, simply move the right-hand guide a bit farther away from the other guide.

Project Design: **Kevin Boyle, Senior Design Editor, WOOD® magazine**

QUICK TIP: DOWEL SCORING

To score hardwood dowels, whether for decorative purposes or to reduce splintering when cutting them, use a tubing cutter or pipe cutter. It produces a clean line with several light twists around the dowel and doesn't tear the surrounding wood fibers.

—Phillip Daniels, Lunenburg, Nova Scotia

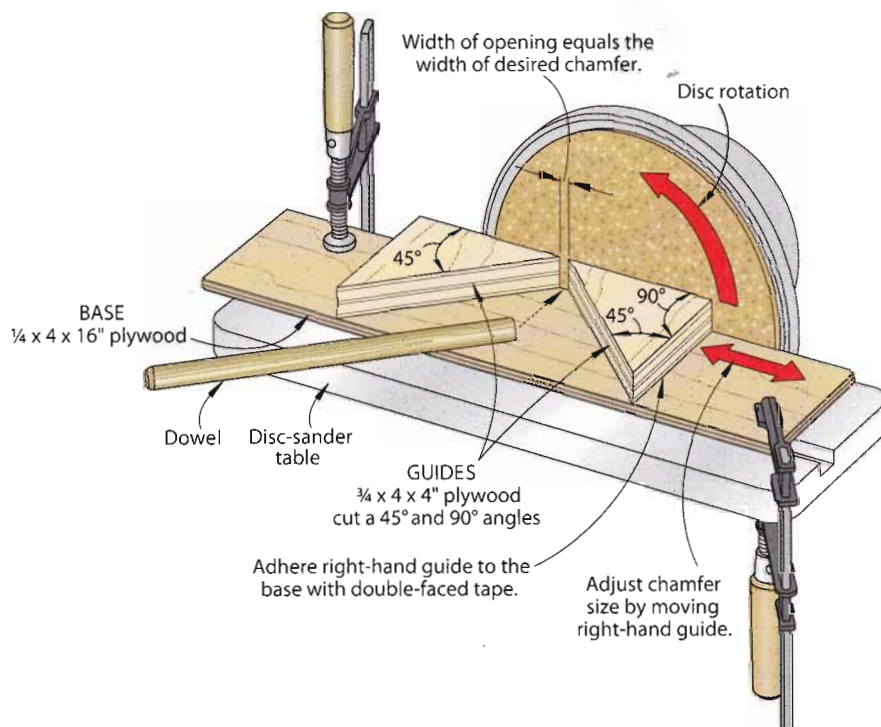

Radial-arm saw **stopblock**

An additional measure of safety for cutoff tasks.

A length stop on your radial-arm saw fence makes repetitive cuts more accurate. But short pieces can get trapped between the blade and stop, damaging them or launching them back at you. To prevent this, build this pivoting stopblock. Vary the shown dimensions as needed to suit your saw.

To use the stopblock, align the cutline on your workpiece with the blade, butt the movable end of the stop against the end of the workpiece and then clamp the opposite end of the stop to the saw's fence. As you pull the saw head toward you to make the cut, the saw head bumps the attached $\frac{1}{4}$ " plywood "sail," pivoting the stop harmlessly out of the way to prevent the offcut from being trapped.

Project Design: **Arthur Hoff, Lakeland, Fla.**

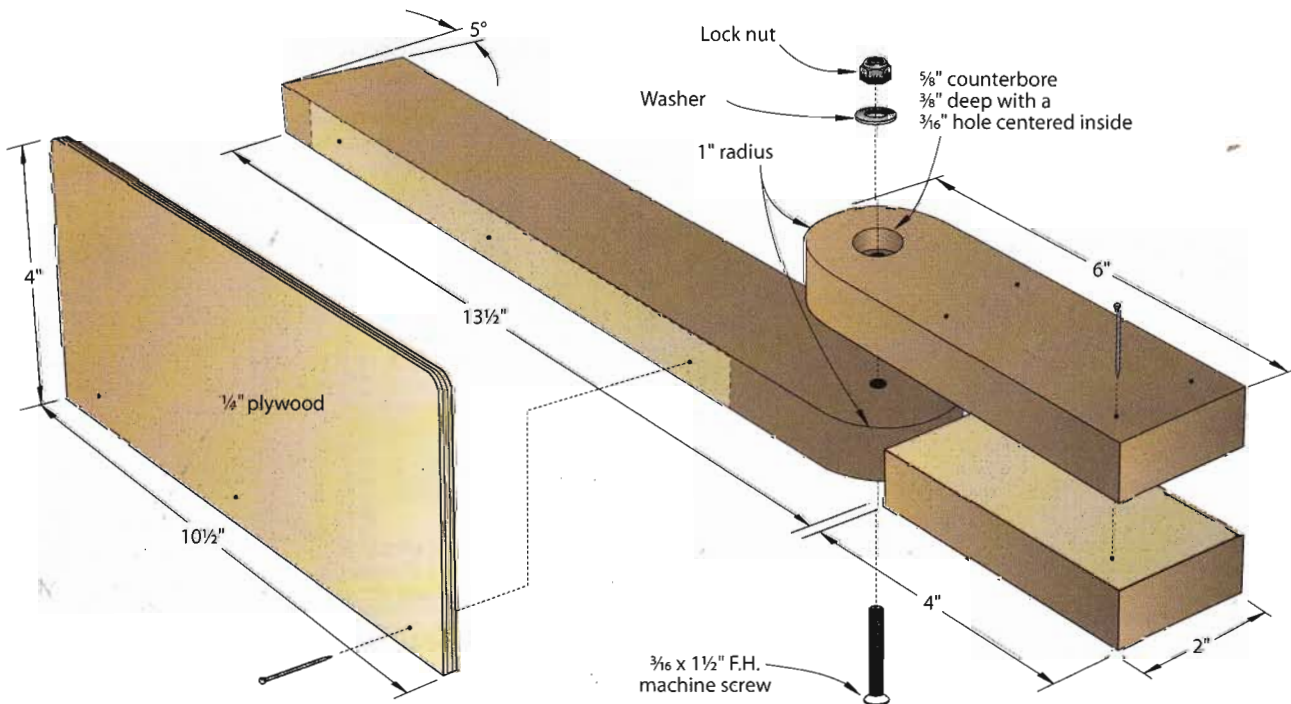
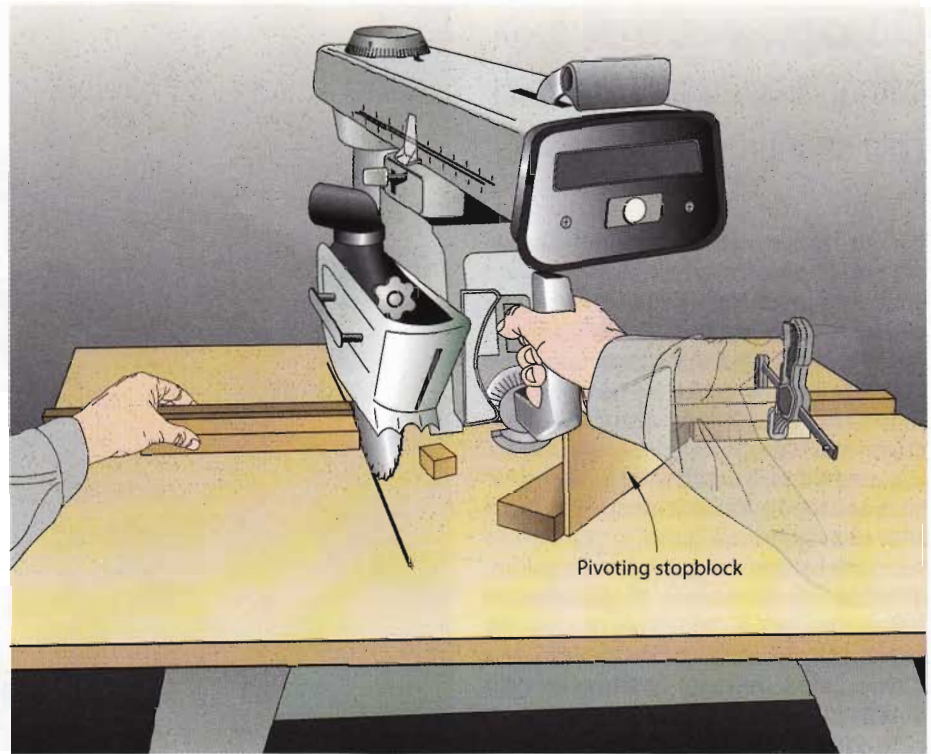

Zero-clearance cutoff guide

This custom-fit guide helps eliminate chip-out.

These two cutoff guides, a 4- and 8-footer, handle a range of workpiece lengths. You can make both guides to custom-fit your circular saw and router from a single sheet of 1/2" plywood. A sheet with sanded faces works best.

Snap a chalk line along the entire length of the sheet 11" from the edge. Using your circular saw, rip along that line. Now, use the factory edge of the cutoff piece as a guide for your circular saw to make the rest of the cuts. From the remaining plywood piece, rip two strips 2" wide, two strips 8" wide, and one strip 11" wide.

Cut the strips to the dimensions shown in **Drawings 1 and 2** and assemble the guides, removing any glue squeeze-out.

Once dry, secure each guide to your workbench, allowing clearance for the saw blade. Using your circular saw with the blade you would commonly use, rip the edge on the wider side opposite the fence, as shown in **Drawing 3**. Do the same for the other side with your router. Whichever diameter router bit you use will be the size you should use in the future for making cutoffs.

2 END VIEW

Line up saw against fence and cut to remove waste.

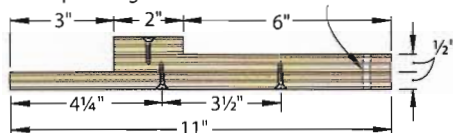

1 EXPLODED VIEW

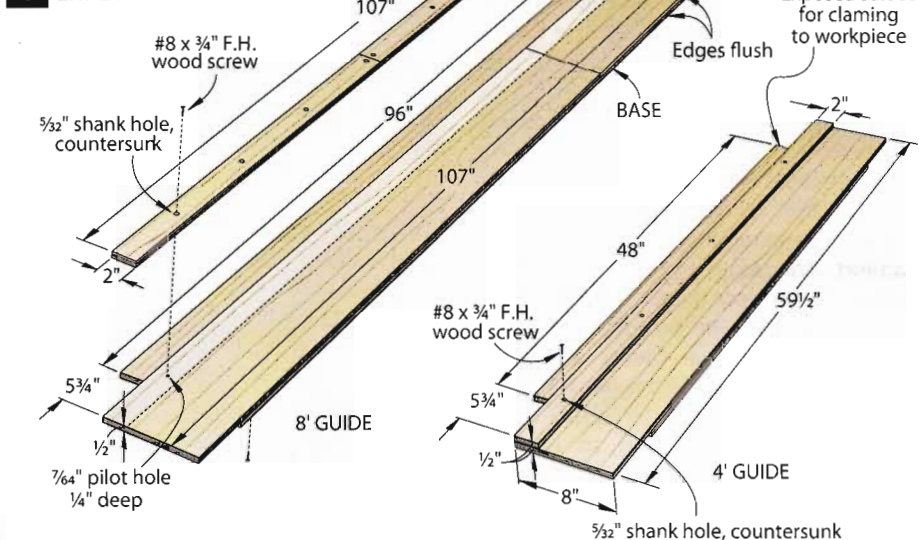

3 TRIMMING THE EDGE OF THE GUIDE

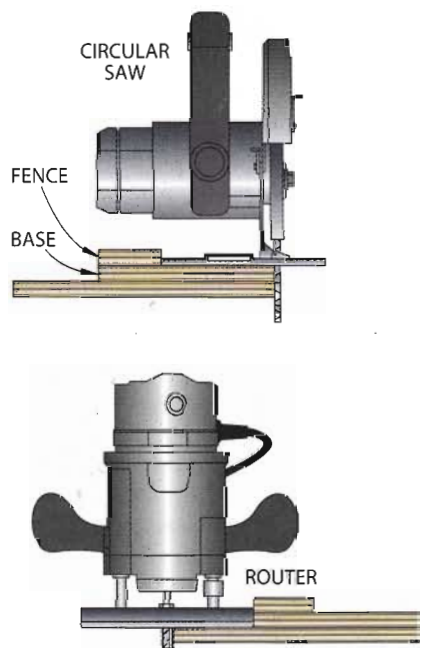

CUSTOM-FIT GUIDE HELPS ELIMINATE CHIP-OUT

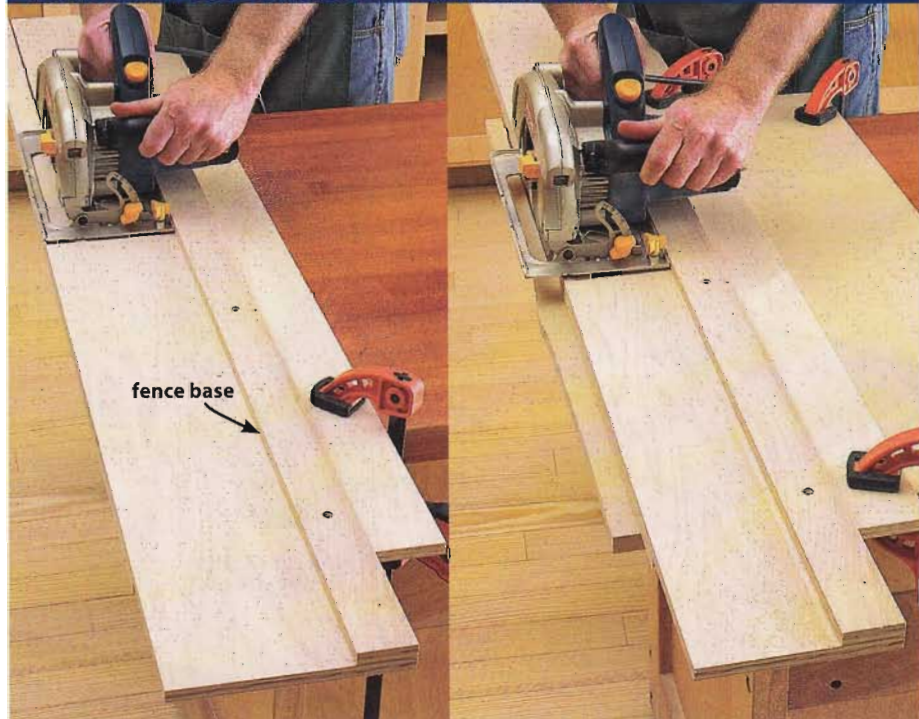

With your circular saw's base riding against the fence, rip the waste off each guide (left). To use the guide, clamp it to a workpiece with the cutoff edge aligned on your mark. Set the saw blade to the appropriate depth and make the cut (right).

Hacksaw dowel trimmer

Cut trimming jobs to the quick with this plug cutter.

A block of wood or scrap of 2x4 stock, a short length of hacksaw blade, and four felt dots are all it takes to make this shop aid. Use the jig to cut off screw-hiding plugs, to trim protruding dowels from dowel joints, or to cut decorative plugs for joinery wherever you want the dowel or plug to protrude slightly.

Build the trimmer shown, routing round-overs along the top edges for hand comfort. The depth of the groove in the bottom of the block determines the length of the dowel or plug protrusion that will remain after cutting. Create a shallow groove in the jig's bottom for trimming dowels nearly flush with the surface of the surrounding wood, leaving an easy-to-sand-flush dowel end exposed. Or, deepen the groove and let the dowel or plug stand proud for a more pronounced effect.

For trimming dowels from edge joints, as shown in the inset at *right*, clamp on a pair of scrap supports to create a larger flat surface for the jig to ride on.



Project Design: **Dale Toms, Bedford, Va.**

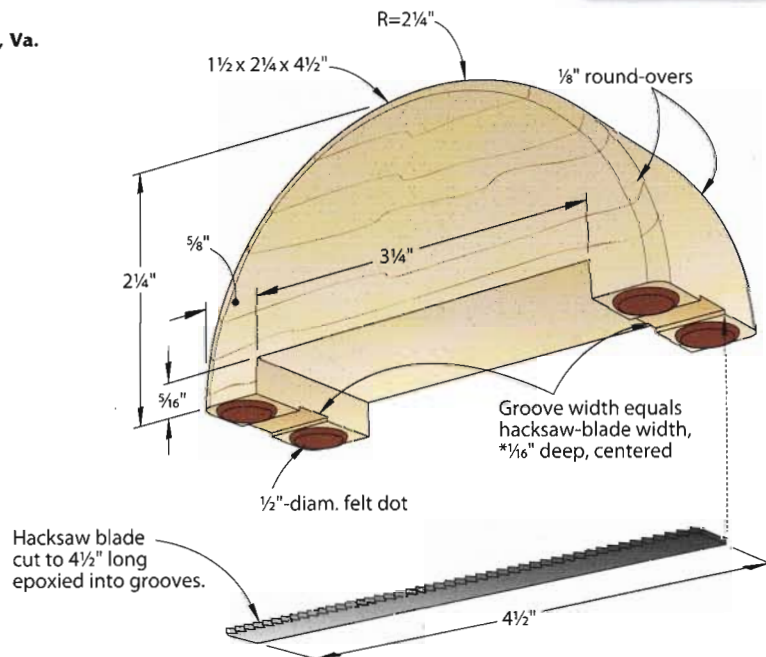

*Adjust this dimension for crosscutting plugs to different lengths.

Easy-adjust picture frame jig

Ensure tight mitered corners while keeping frames flat

If you've ever assembled a picture frame, you know the difficulties of creating seamless miters and a flat glue-up. Sometimes, numerous clamps and an extra set of hands don't seem to be enough. *WOOD* magazine reader Dennis Parrot of Greenfield, Massachusetts, solved that with this adjustable frame jig.

Cut the base and braces, as dimensioned in **Drawing 1**; make the corner clamp according to **Drawing 2**. Our jig measures 27x32", but you can adjust the dimensions of your jig to work for frames of just about any size. The three braces across the bottom act as cleats to keep the base flat when applying clamping pressure.

Glue and clamp the corner clamp parts together. The overhanging hardboard captures the clamp banding when using the jig. After marking diagonals on the base to locate the slot centerlines, we drilled a $\frac{5}{16}$ " hole at the end of each slot, connected the outer edges of the holes with straight lines and cut the slots to shape with a jigsaw. Sand all the parts smooth and apply a clear finish. Then, secure a corner clamp to each slot with bolts, washers, and wing nuts, allowing just enough slack so the clamps can slide on the base.

To use the jig, place a corner clamp at each corner of the frame being clamped. Waxed paper beneath the frame corners prevents the glued joints from adhering to the base. Wrap a 1"-wide band clamp around the corner clamps and tighten, as shown in the photo.

Project Design: **Dennis Parrot, Greenfield, Mass.**



1 EXPLODED VIEW

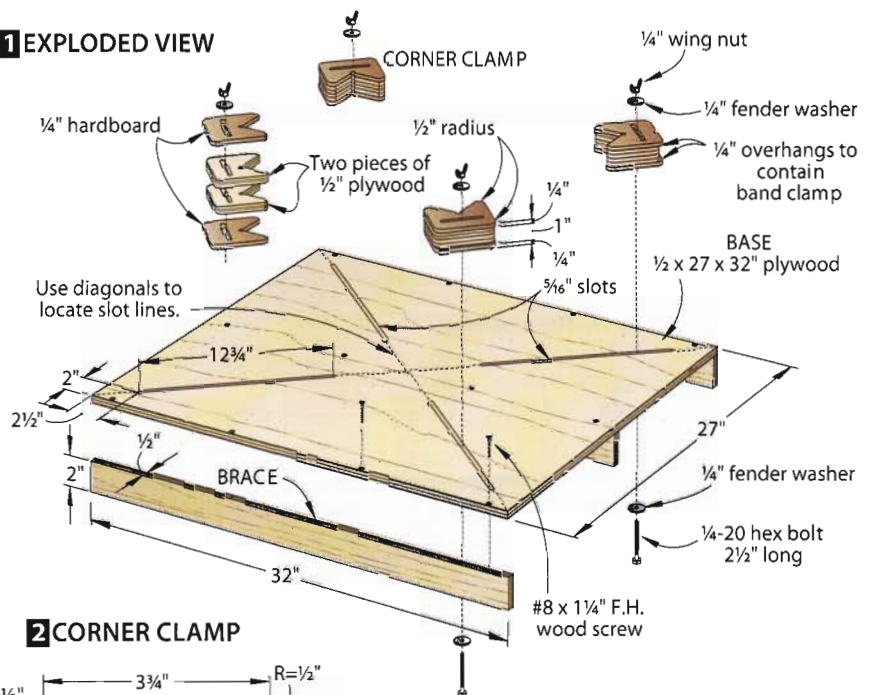

2 CORNER CLAMP

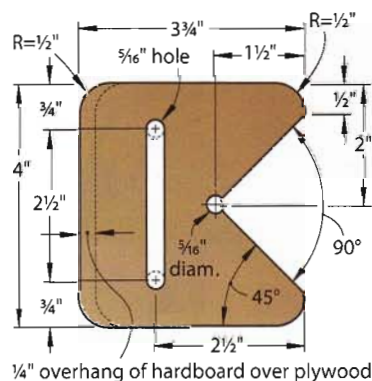

Edge-banding clamp guides

Perfect alignment makes for perfect clamping.

You can use these shop helpers when edge-banding any cabinet or shelf part. But they really save the day when attaching bands after assembly when there's no room for error. Such is the case with the dresser carcass being built in **Photos A and B**.

To build the guides, cut pairs of 3x4" alignment blocks from scraps of 3/4" plywood. (We recommend one guide for every 8" to 10" of band length.) Then, cut spacers from scraps of the plywood, particleboard, or medium-density fiberboard you'll be edge-banding. To keep excess glue from sticking to the guides, apply plastic packing tape to the alignment blocks, where shown on the drawing. Next, clamp a spacer between each pair of alignment blocks, drill countersunk screw holes and drive the screws.

To use the guides, first plane the edge bands to the exact thickness of the panel receiving them. Use one of the guides as a thickness gauge to test the edge bands to ensure a tight fit. Then, follow the two steps shown in the photos *below*. 🌲

Project Design: **Chuck Hedlund, WOOD® magazine Master Craftsman**

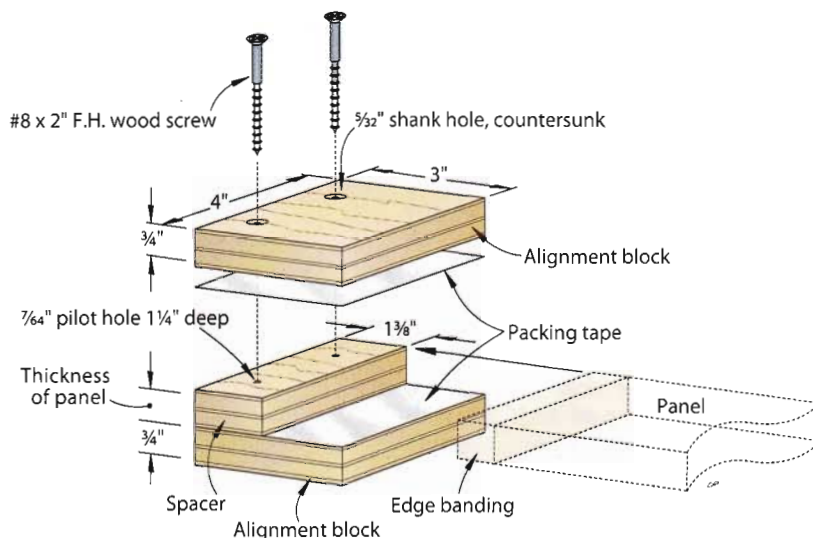
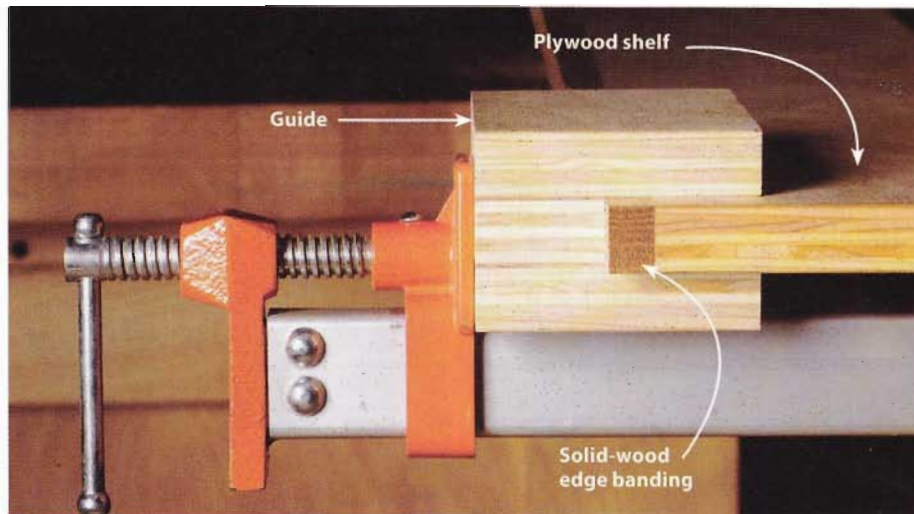

TWO EASY STEPS TO PERFECTLY ALIGNED EDGE-BANDING

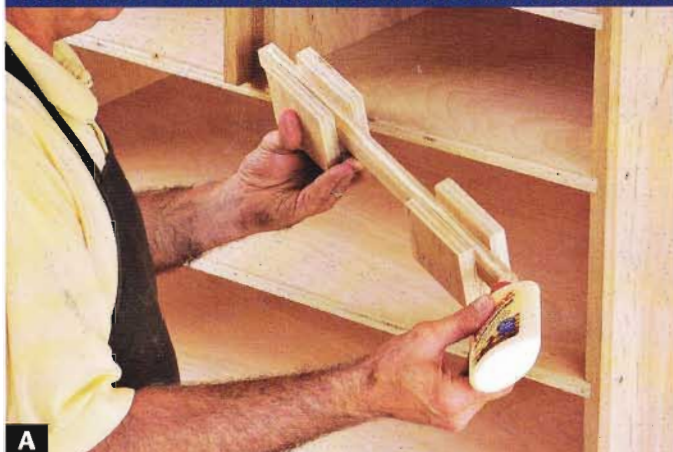

A With the edge banding seated within the clamping guides, apply a centered bead of glue. To avoid squeeze-out, apply glue sparingly.



B Clamp the edge banding into place. To give the far clamp jaw a surface to bear on, apply the edge bands with the case back off.



Create your custom products with an Epilog Laser system!

Systems starting at \$7,995!

- Custom engrave your products – from cabinet doors, to cigar boxes, to gun stocks.
- Cut intricate models from any type of wood, acrylic, leather, plastic, paper, and much more.
- With lease payments starting at about \$150/month*, Zing laser systems are unbelievably affordable!



Find out how to get your own laser. Call 888-437-4564

MADEINUSA

sales@epiloglaser.com • www.epiloglaser.com/bhg.htm

*With Approved Credit

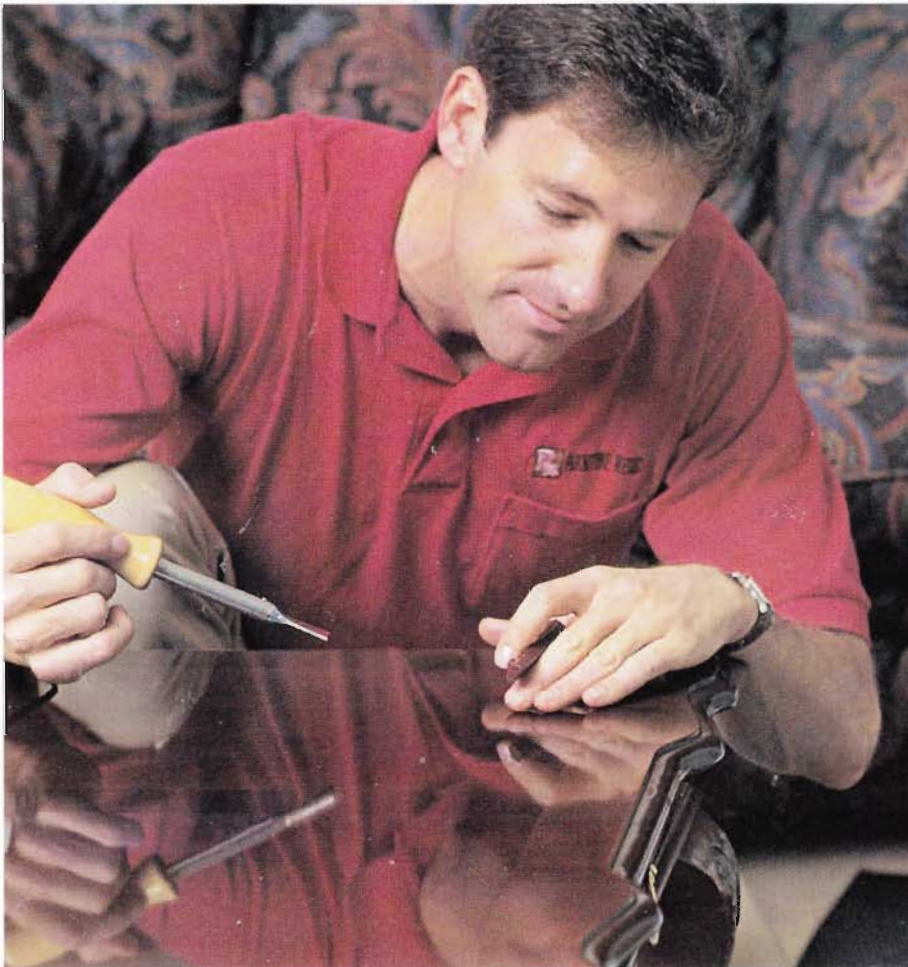

Refinish Your Future.

Own your own business.

Let your passion for furniture lead you into a new business with a Furniture Medic franchise. We're a complete on-site repair and restoration-refinishing business servicing homes and companies as well as handling moving and insurance claims. We offer extensive training and support with a low initial investment and manageable overhead. Financing is available to qualified candidates and franchises are offered nationwide. Call today to brush up on the details.

1-800-RUN YOURS
www.furnituremedicfranchise.com



Supports, Stands, and Worksurfaces



SUPPORTING PLAYERS In Hollywood the best actors rely on the help of others; without a support cast, even A-list performers can't do their best work. The same is true in the workshop. This collection of work supports, tool and equipment stands, and rock-solid worksurfaces makes your work as accurate and safe as possible.

Flip-up pipe-clamp supports

Upright and ready to go when you need them, folded down and out of the way when you don't, these pipe-clamp supports add versatility to any workbench.

Frustrated with pipe-clamp holders tipping over as he worked, Paul Amberg came up with some ingenious flip-up supports for his workbench. A short piece of dowel slips into holes to keep the hinged holders in the up and down positions. For a 6'-long bench, cut out the pipe supports and stabilizers to the dimensions shown in the illustration *below*; for a bench of a different size, adjust the dimensions to match what works best for you. Add the hardware and mount it to your benchtop. Now, drill dowel holes into the ends of the benchtop to line up with the holes in the stabilizers. To protect the workbench from glue drips, mount a roll of paper beneath the bench for easy access.

Project design: **Paul Amberg, Hubertus, Wis.**

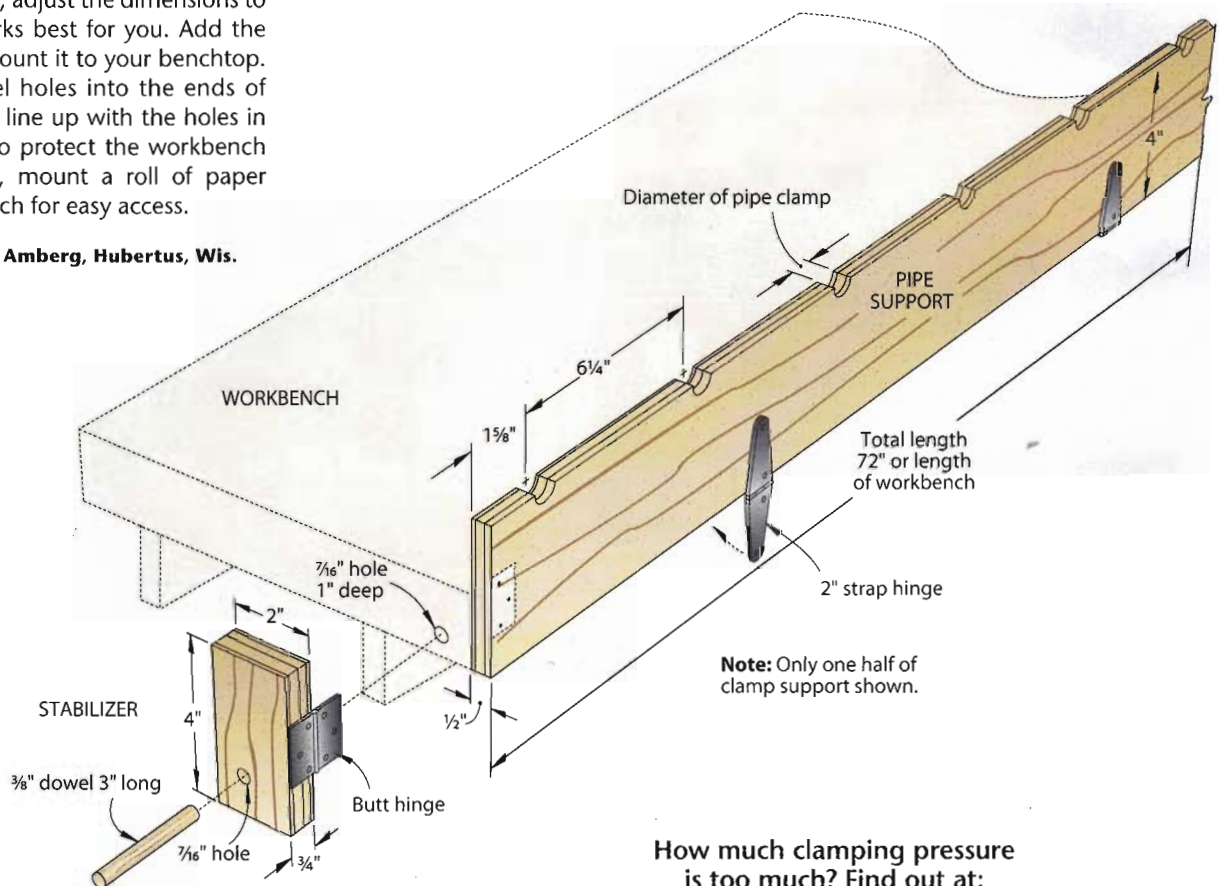

How much clamping pressure is too much? Find out at: woodmagazine.com/clamppress



Double-duty outfeed table

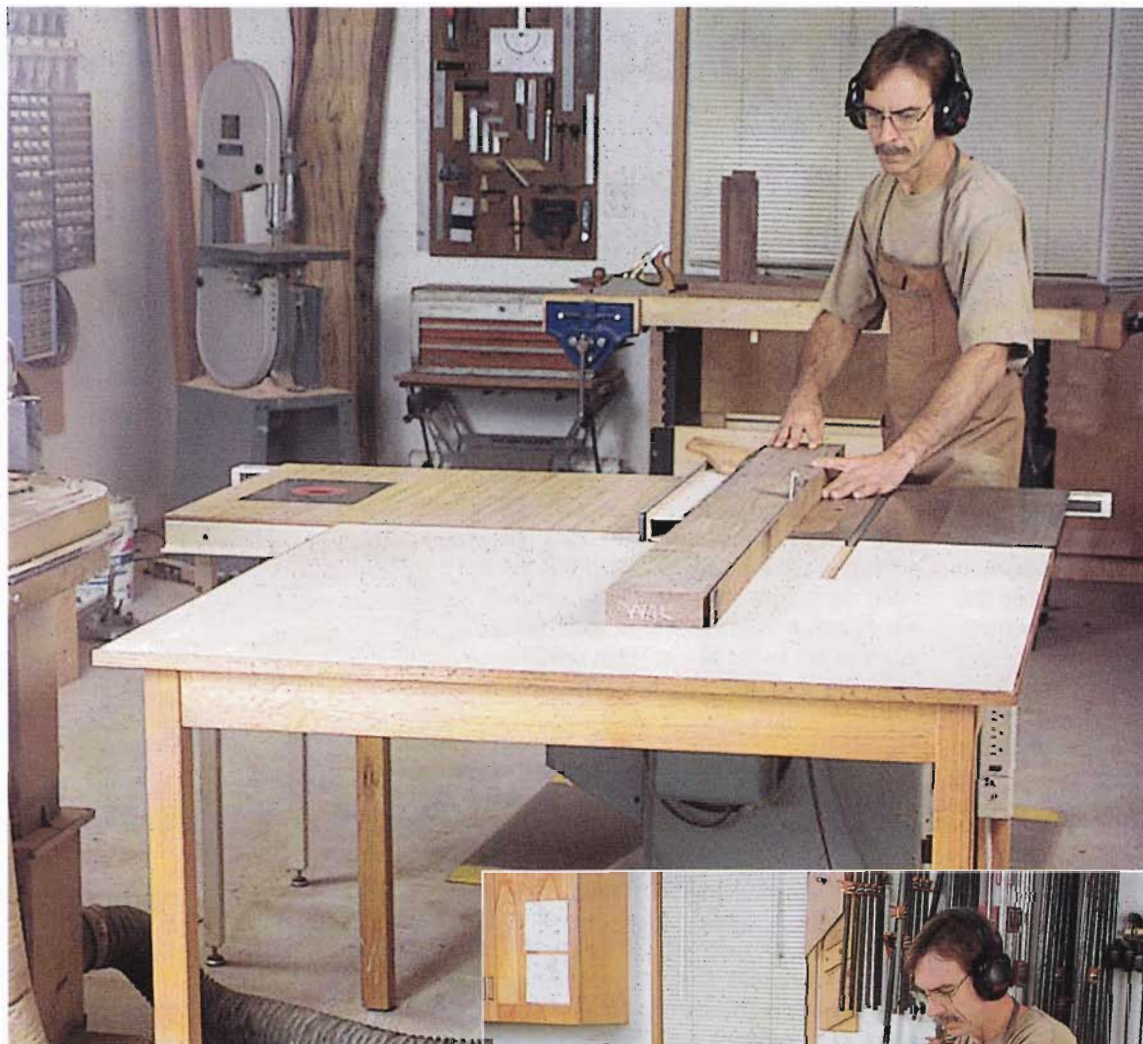

Use this outfeed support for both your tablesaw and portable circular saw.

This simple table handles two kinds of cutting chores: First, it's helpful when ripping long boards, as shown *above*, and it's just as handy rough-cutting large sheets of plywood, at *right*. For sheet goods, just pull the table away from the saw, attach a cutting guide to the panel and make the first cut with the circular saw. Next, remove the waste, slide the panel over to the tablesaw and trim it to size. When not used for cutting, the table serves as a surface for project assembly.

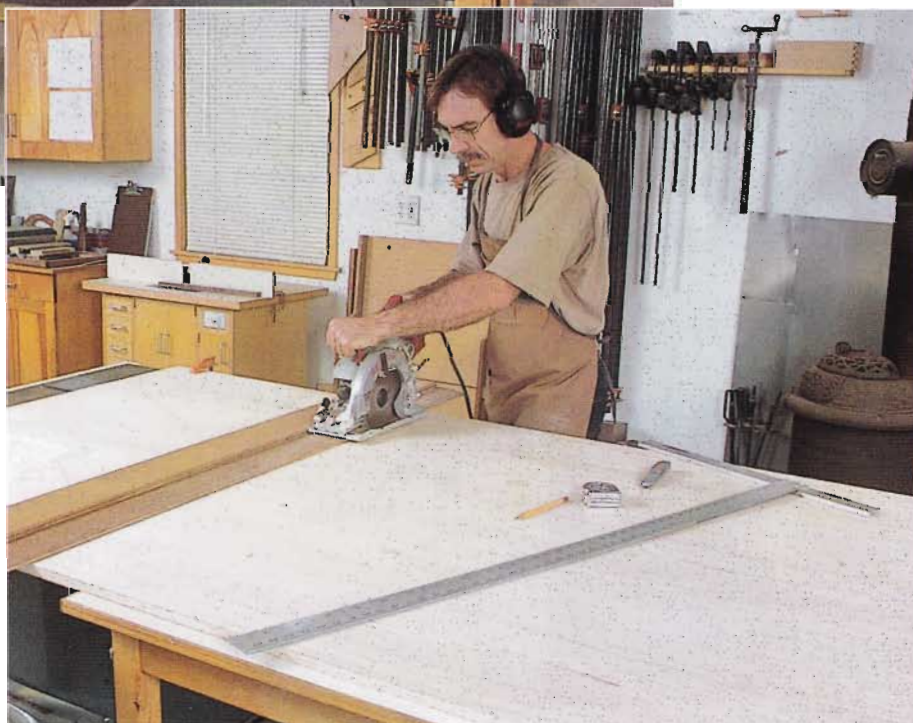

TOP: Having a big outfeed table at the far end of your saw is the best way to keep control over long boards or sheet goods during the cut. **ABOVE:** Pulling the table slightly away from the saw transforms the outfeed table into a plywood crosscutting station.

To construct this outfeed table, first measure the height of your tablesaw to determine the total height of the table, being sure to factor in the melamine top, legs, and lag-screw levelers [Drawing 1]. You'll want to keep the table's height just below the saw table so you can adjust up to it with the lag screws.

Attach the table aprons to the 2x2" legs using mortise-and-tenon joinery [Drawing 1a]. This will better help the table withstand the stresses encountered if you need to rearrange your shop or drag the table to different locations to fill different needs.

After cutting the parts to size, cut the mortises with a hollow-chisel mortiser or with a combination of drill press and hand chisels. Machine the tenons on the table-saw or a router table.

Test-fit the aprons and legs, and then measure the center rail to fit and cut biscuit slots, where shown. Next, drill the pocket-screw holes for attaching the top. After cutting and drilling the parts, glue and clamp the aprons to the legs.

To make the top, cut a sheet of 3/4" melamine-coated particleboard to size and then cut and attach the edging with

glue. Screw the top to the rails; then flip the table over and insert the lag-screw levelers. Adjust the table height so that it's about 1/16" below the height of your saw. Finally, mark the location of your saw's miter-gauge slots on the tabletop. Rout these grooves so the top won't interfere with the travel of the bar on your miter gauge or with any other jigs you have that use these slots.

Project design: **Paul Anthony, Rigelsville, Pa.**

1 EXPLODED VIEW

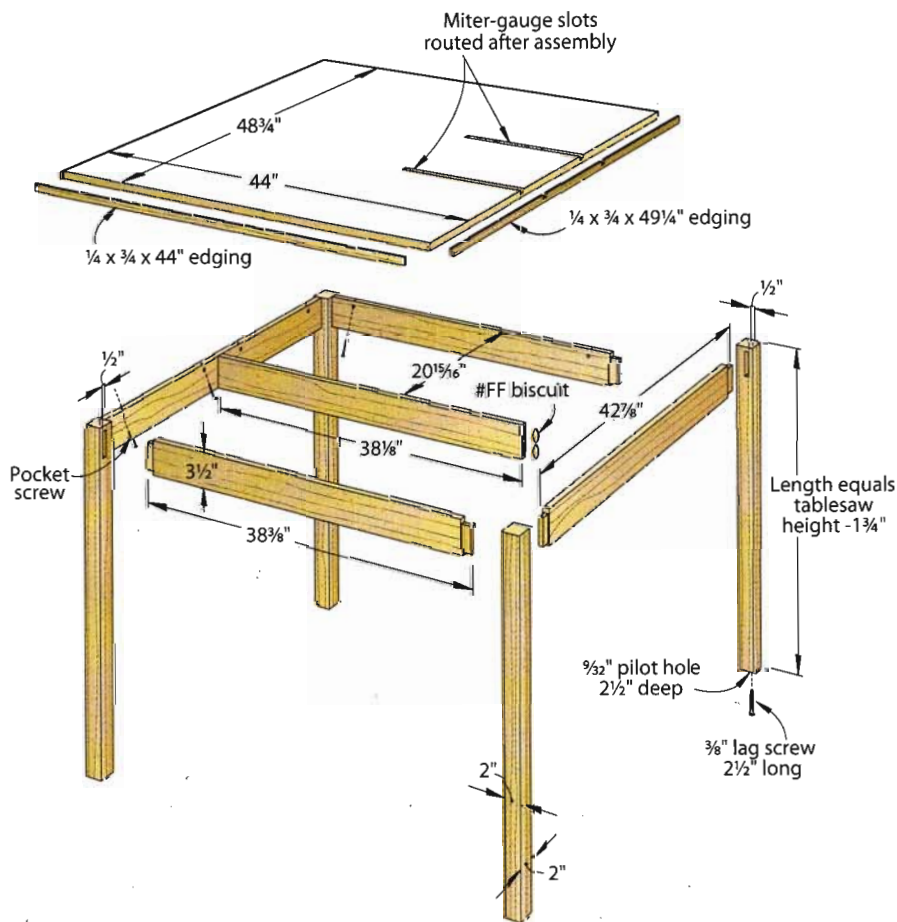

1a MORTISE-AND-TENON DETAIL

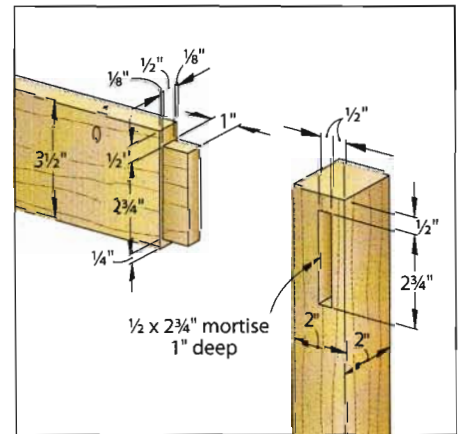

QUICK TIP: FIXING TOO-SMALL TENONS

Getting a tenon to fit a mortise snugly can be tricky; a lot of little things can happen to produce a tenon joint that doesn't have the snug fit necessary for a strong joint. Rather than trashing the undersized member, cut some thin shavings from a scrap piece of the same material with a hand plane. Glue these thin shavings to the tenons and then sand to fit.

—David A. Alexander, Oneonta, N.Y.

Mobile utility bench

The perfect size for smaller tasks, this handy bench rolls—and then stays—wherever you need it most.

For a shop with limited space, or when you need some additional work surface for a project, this small bench fills the bill. With casters on one end only, you can easily move it like a wheelbarrow, yet the bench is rock-solid when lifted off the caster with the load leveler. The bench shown here features alder sides, exterior-grade $\frac{3}{4}$ " medium-density overlay (MDO) for the carcase, and construction-salvage oak 2x4s for the benchtop. Laminating the top with 2x4s it makes for a more stable than a solid slab.



Project design: **Dale Faulstich, Sequim, Wash.**

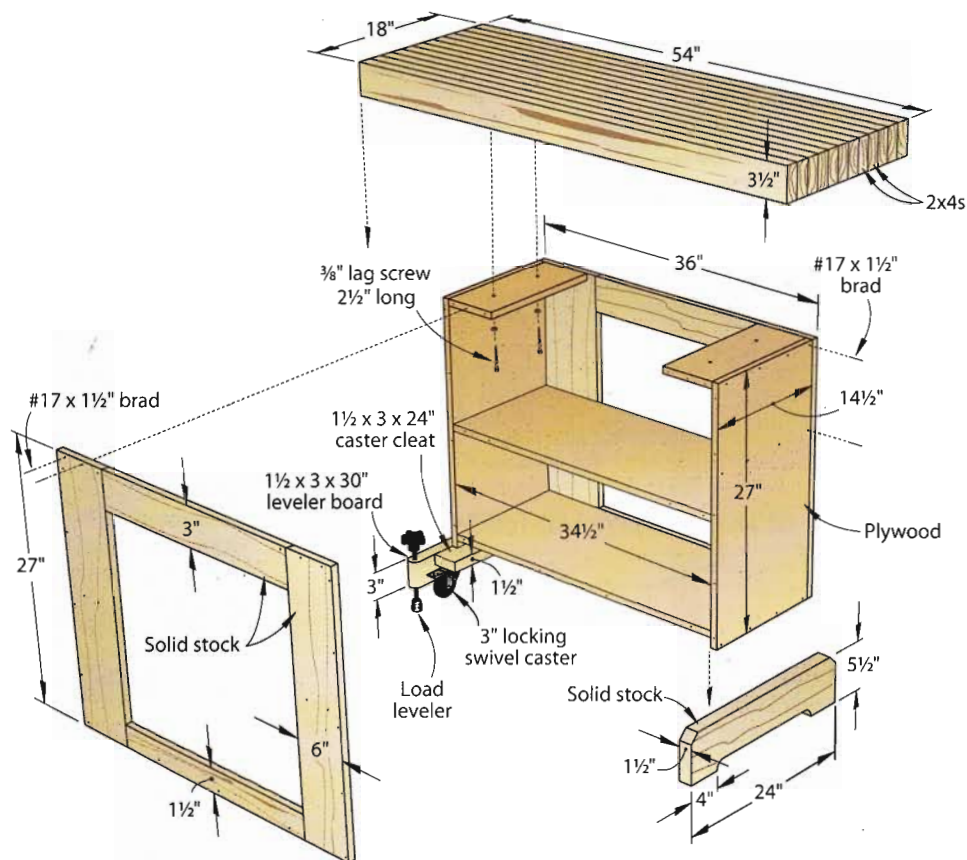

Folding **assembly table**

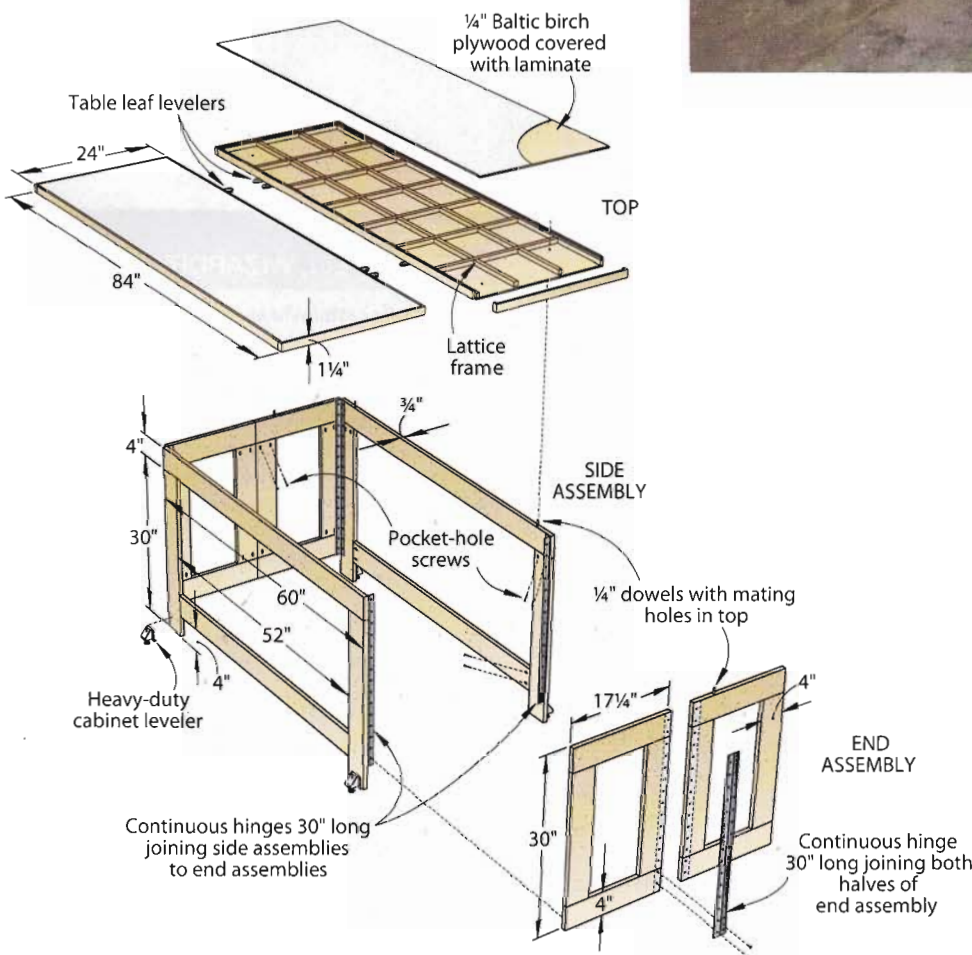

Use it. Fold it. Then store this table in a minimum of space.

This versatile table with a removable worksurface allows Jeff Tobert some additional space to assemble projects, and gives him a larger outfeed space when aligned with the regular outfeed table on his tablesaw. Continuous hinges allow the folding end assemblies to collapse for easy storage. Each leaf of the tabletop consists of two plywood skins over lattice frames, covered with plastic laminate. Install cabinet levelers at each corner so you can adjust the table to match just about any uneven surface inside—or outside—your shop.

NOTE: Jeff used continuous (piano) hinges for his table, but to save money, consider using less-expensive butt hinges.

Project design: **Jeff Tobert, Spruce Grove, Alta.**

On-the-go storage cart

When you need supplies out of the way without putting them away, this wheeled wonder saves the day.

This storage cart not only gives you a place to stash just about any kind of shop gear and supplies, but the free-wheeling design allows you to move them wherever you're working, with no heavy lifting. And with a height of just over 2', it makes a perfect low-boy assembly table for furniture-size projects. Made almost entirely with simple butt joinery, the cart goes together in a weekend with plywood and standard dimensional lumber from the home center—or from your scrap bin.

Project design: **Tom Whalley, Urbandale, Iowa**

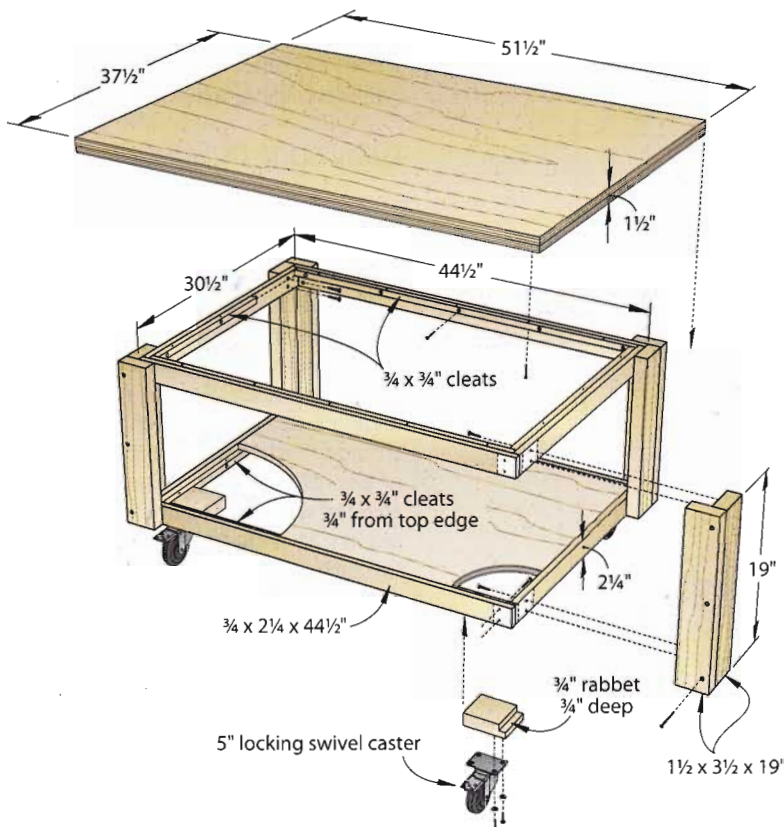

QUICK TIP: WORN-WHEEL WIZARDRY

Hard-plastic caster wheels on some machine bases and shop utility carts can crack or break up after awhile. Replacing the entire caster can be costly if you have several that need your attention. Don't replace the entire caster, just the wheel. Remove the original wheel by grinding the staked end of the caster axle. Make the new one from scrap hardwood. To cut the wheel, set your hole-cutter radius to that of the original wheel minus the thickness of your new tire material. (Strips cut from inner tubes work great.) Glue the tire to the wheel with cyanoacrylate adhesive, fastening the ends with tacks. Use a bolt of the appropriate diameter and length for the new axle, enlarging the hole-cutter pilot-bit hole to fit.

—Larry McConnell, Medford, Ore.

Best-Ever Plans for Workshop Tools & Accessories

1,000+
woodworking plans at
woodmagazine.com/plans

from the editors of **WOOD**® magazine



**Space-Saving Double-Duty
Tablesaw Workbench**
Plan DP-00553a \$7.95



Go-Anywhere Tool Caddy
Plan DP-00426 \$6.95



Shop Cart/Workbench
Plan DP-00592a \$4.95



Traditional Workbench
Plan DP-00482 \$7.95



Bench-Tool System
Plan DP-00560 \$6.95



Roll-Around Tool Base
Plan DP-00061 \$6.95



Folding Work Table
Plan DP-00620 \$1.99

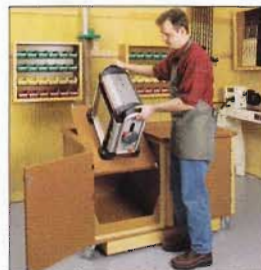

Flip-Top Work Center
Plan DP-00239 \$5.95



Mobile Miter Saw Center
Plan DP-00098 \$7.95



Full-Service Workbench
Plan, Part 1, DP-00058 \$8.95



**Five Great Clamp
Organizers**
Plan DP-00230 \$6.95



**Basic Workbench and
6 Ways to Beef it Up**
Plan DP-00456 \$7.95



**Simple 'N' Sturdy
Tool Stand**
Plan DP-00577 \$4.95



**Mobile Sawing
& Routing Center**
Plan DP-00271 \$8.95



Mobile Tool Cabinet
Plan DP-00260 \$7.95



Mobile Storage
Plan DP-00321 \$2.75



Space-Saving Work Center
Plan DP-00168 \$6.95



Get'r-Done Shop Cart
Plan DP-00486a \$4.95



Lumber Storage Rack
Plan DP-00135 \$7.95

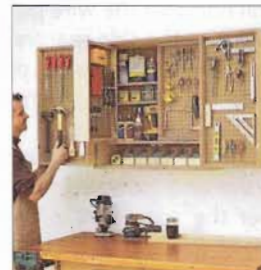

Shop-in-a-Box Tool Cabinet
Plan DP-00518 \$5.95

Download any of these woodworking plans for the prices listed, or view a larger image, at woodmagazine.com/plans
To have paper plans mailed directly to you (add \$3 per plan plus S+H), call **toll-free 1-888-636-4478**.

Please have your credit card available.

Rolling **tool cabinet**

This little stowaway offers some much-needed storage and an extra worksurface, but never gets in your way.

When it comes to convenience, mobile tool storage is hard to beat, especially when it stows out of the way in a corner or beneath a tablesaw extension wing, as shown at *right*. The perforated-hardboard sides hang tools and accessories, while the interior provides shelves and a partition to keep things organized, as seen in **Drawing 1**. See the specific dimensions in the **Materials List** for the cabinet shown here, but change them as needed if you're building a cabinet to be stored in a specific spot.

To build the cabinet, cut the carcass pieces (A–E) to size from $\frac{3}{4}$ " medium-density fiberboard (MDF) and $\frac{3}{4}$ " maple. Be sure to make right and left sides (mirror images) for the sides (B) based on **Drawing 1a**. Cut the dados and rabbets where dimensioned. Lay out the $\frac{1}{4}$ " shelf-pin holes on the sides. Drill the $\frac{3}{8}$ "-deep holes using a drill bit with stop collar attached.

Apply glue to the rabbets and dados in the sides, subtop, and bottom and then glue the cabinet together, capturing the center partition (C) where shown.

Glue the supports (E) in place. Cut the shelves (F, G) and shelf edging (H), and band the shelf edges.

Now, cut the doors (I) and rout a $\frac{1}{4}$ " round-over along the front edges of each. Drill holes for the wire pulls and install the pulls. Cut the side spacers (J, K) to size and glue and screw them onto the cabinet sides (B), keeping them flush with the sides' outside edges.

Cut the perforated hardboard sides (L) to size and glue and screw them in place over the spacers. Cut the bottom cleats (M) to size and screw them in place, flush with the outside edges of the perforated hardboard sides.



Finally, attach the casters to the bottom cleats using #10 \times $\frac{1}{4}$ " panhead screws with $\frac{1}{4}$ " flat washers. Fasten the doors to the cabinet with no-mortise wraparound hinges, as shown. Screw on roller catches to secure the doors when closed. Round over the edges of the replaceable top (D) and screw it on.

Project design: **Kevin Boyle, Senior Design Editor, WOOD® magazine**



Materials List

Rolling tool cabinet	FINISHED SIZE			Matl. Qty.
	T	W	L	
A subtop and bottom	3/4"	31 1/4"	32"	MDF 2
B sides	3/4"	32"	23 1/2"	MDF 2
C center partition	3/4"	22 3/4"	31 1/4"	MDF 1
D replaceable top	3/4"	35"	35 1/2"	MDF 1
E supports	3/4"	2"	30 1/2"	M 2
F deep shelves	3/4"	20 1/4"	30 1/4"	MDF 2
G narrow shelves	3/4"	9"	30 1/4"	MDF 2
H shelf edging	3/4"	1 1/4"	30 1/4"	M 4
I doors	3/4"	15 5/16"	23 3/8"	MDF 4
J hor. side spacers	3/4"	2"	28"	MDF 4
K vert. side spacers	3/4"	2"	23 1/2"	MDF 4
L perforated hardboard sides	1/4"	32"	23 1/2"	PH 2
M bottom cleats	3/4"	4"	32"	MDF 2

Materials key: MDF—medium-density fiberboard, M—maple, PH—perforated hardboard.

Supplies: 2" no-mortise wraparound hinges (8); 4" wire pulls (4); 4" casters (2); 4" swivel casters with brake (2); 1/4" shelf supports (16); roller catches (4); #8x3/4" round-head wood screws (24); #8x1 1/4" flathead wood screws (28); #10x1 1/4" panhead screws (16); 1/4" flat washers (16).

Blades and bits: Dado-blade set; 1/4" round-over router bit; 1/4" brad-point drill bit.

Sources

Casters. Set of 4: 2 swivel, 2 rigid, no. 00K20.10. Lee Valley; 800-871-8158, leevalley.com.

Lumber storage system. 24" wall straps no. 17K20.02 (4); 14" brackets no. 17K20.06 (8); Lee Valley; 800-871-8158, leevalley.com.

QUICK TIP: STEALTHY STORAGE

Smaller tools and shop accessories that only get occasional use don't deserve premium bench space or room in shelves and storage cabinets. Make better use of available space by storing tools on low carts sized to roll underneath benches or other cabinets. Assemble the cart from 3/4" stock for the sides, 1/2" plywood for the bottom, and four casters.

—Janell Johnson, Whitehorse, Yukon

1 EXPLODED VIEW

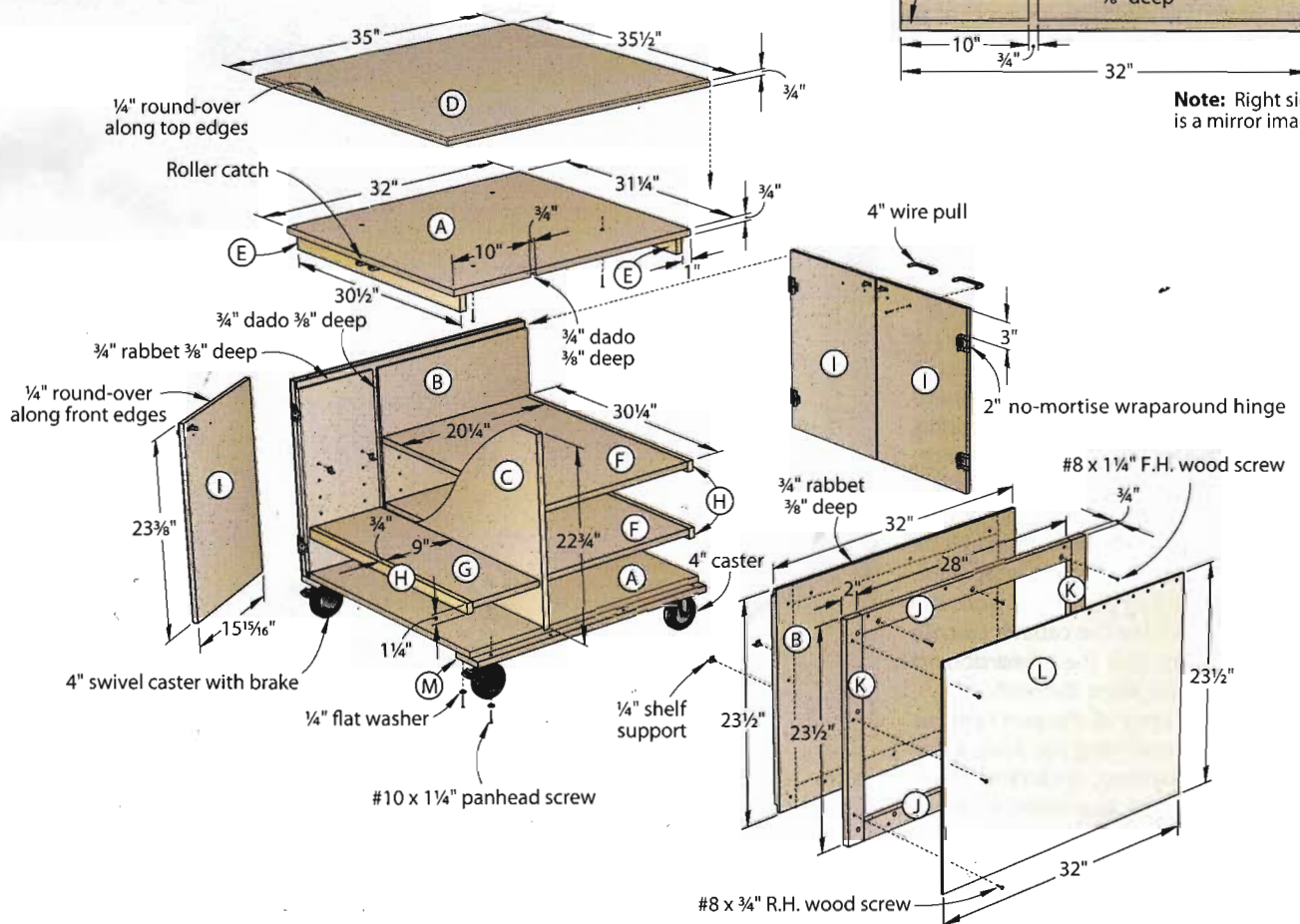

1a INNER LEFT SIDE DETAIL

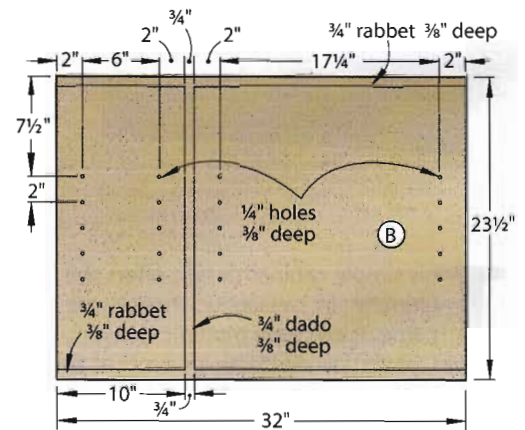

Note: Right side is a mirror image.

"Versa-cab" tool cabinet system

Vertical or horizontal, shelves or dividers—with these flexible cabinets the choice is always yours.

Editor's Choice

Add, subtract, or change the shelf configuration as your shop needs evolve.

A.J.H.



This simple cabinet design offers the ultimate in versatility; hence the name. It can have multiple drawers, shelves, or vertical dividers—or a mix of all three. Use it vertically as a base cabinet on the floor or mount it vertically or horizontally on the wall. The dividers lay loosely in their slots so you can quickly reconfigure the layout of each cabinet as needs change. The cabinet size makes optimum use of a sheet of medium-density fiberboard (MDF), and spacing between the dividers proves ideal for medium-size drawers and many smaller tools, tool cases and other items.

Overall the cabinet (when vertical) is $15\frac{3}{4}$ " deep, $13\frac{1}{4}$ " wide, and $38\frac{1}{4}$ " high. At its most basic it has three equal compartments of $11\frac{3}{4}\times 11\frac{3}{4}\times 14\frac{3}{4}$ ". The individual spaces, with dividers in place, are $3\frac{3}{4}$ " wide.

When routing the $\frac{1}{4}$ " wide, $\frac{3}{8}$ " deep grooves for the cabinet backs and drawer bottoms, the $\frac{1}{4}$ " hardboard should fit a bit loosely into the grooves. If the fit is too tight, the remaining lip may split away from the MDF. As you assemble the cabinet carcass and drawer boxes, glue the $\frac{1}{4}$ " hardboard into the grooves for extra strength.

We found that once all the parts are cut and routed, and assuming you have a finish nailer, each cabinet, including three drawer boxes, can be assembled in about an hour.

Project design: **Kevin Boyle, Senior Design Editor, WOOD® magazine**

ASSEMBLING THE VERSA-CAB

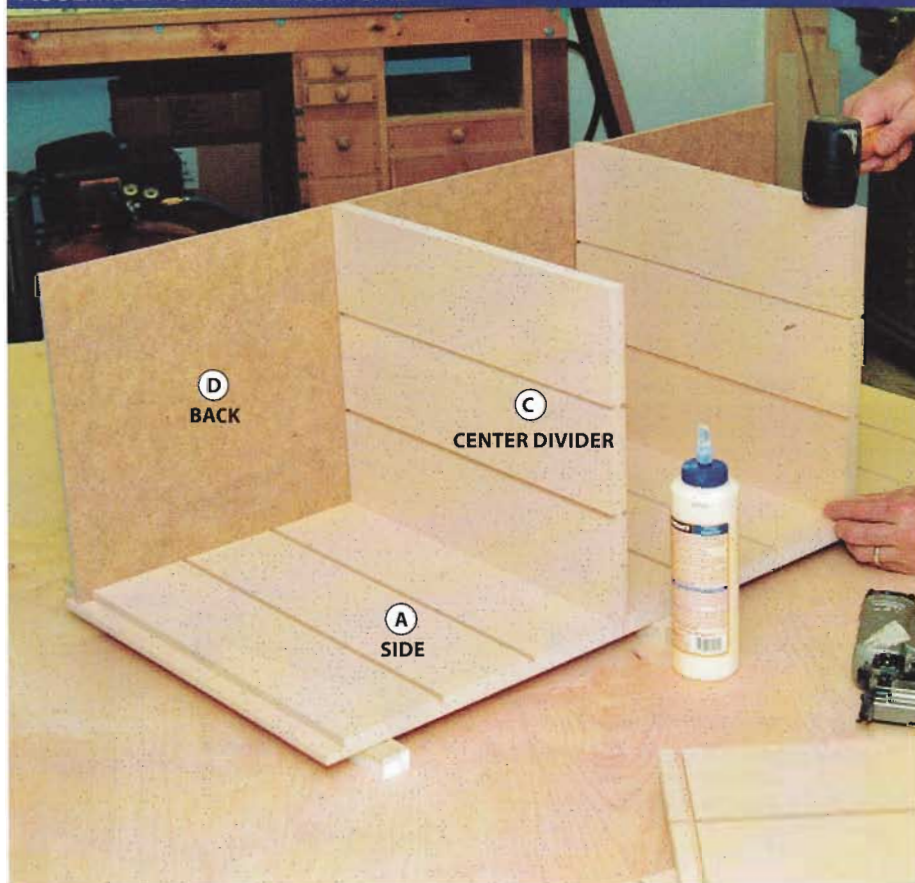

Assemble the Versa-cab by gluing and fitting the center dividers (C) and the cabinet back (D) to the sides (A). Glue and nail the dividers and cabinet ends, square the cabinet and then nail through the back into the dividers to stiffen the cabinet.

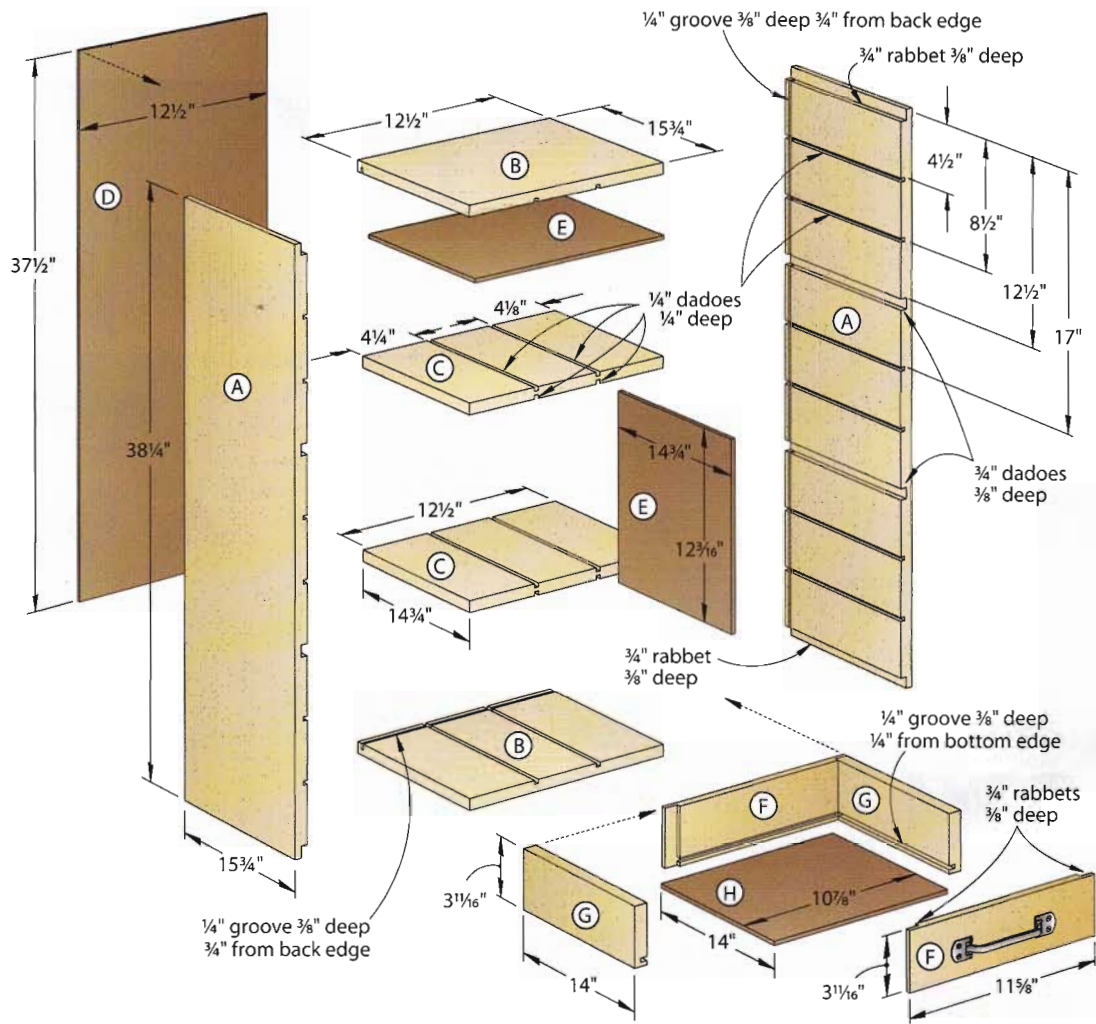

SLIDE-IN SAW-BLADE STORAGE

Materials List

Versa-cab	FINISHED SIZE			Matl. Qty.		
	T	W	L			
A	sides	3/4"	15 3/4"	38 1/4"	MDF	2
B	top and bottom	3/4"	15 3/4"	12 1/2"	MDF	2
C	center dividers	3/4"	14 3/4"	12 1/2"	MDF	2
D	back	1/4"	12 1/2"	37 1/2"	HB	1
E	partitions	1/4"	12 3/16"	14 3/4"	HB	6
F*	drawer front and back	3/4"	3 1/16"	11 5/8"	MDF	2
G*	drawer sides	3/4"	3 1/16"	14"	MDF	2
H*	drawer bottoms	1/4"	10 7/8"	14"	HB	1

* Quantity for one drawer

Materials key: MDF—medium-density fiberboard, HB—hardboard.



For wall installation, add a horizontal cleat inside the cabinet and to its back, securing it to the sides. Then, drive screws through the cleat and back into the wall studs. To increase the versatility of the partitions, add a dowel for storing circular-saw blades of 10" or less.

Mitersaw work station

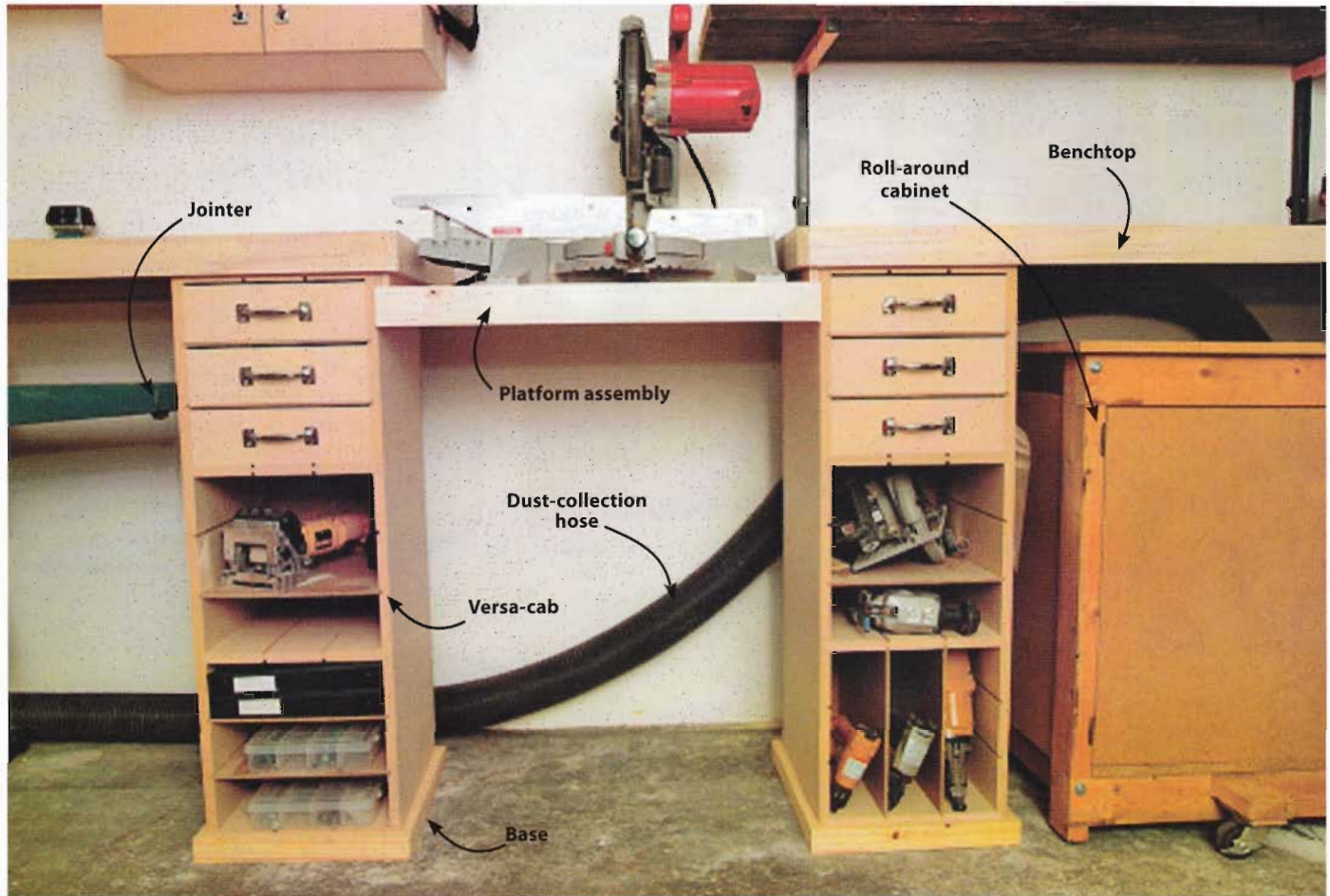

As base cabinets supporting the worksurface, the flexible Versa-cabs accommodate multiple drawers, shelves, and vertical dividers. The division of space within the cabinets allows for storage of smaller tools and other items. The space behind the cabinets provides plenty of room to run the dust-collection hose out of the way and to the jointer.

This perfect home for your miter saw offers lots of space and storage.

A miter saw is one of the busiest tools in any workshop and, as such, it deserves a permanent home. If that home can offer an additional worksurface and extra storage capacity, so much the better. You can ensure plenty of both by giving this miter saw work station an entire wall in your shop, if possible, and centered on the wall to allow maximum cutting length to the left or right.

Two Versa-cabs from the project on *page XX* function as base cabinets and support the countertops on either side of the miter saw. Wall cleats (D) screwed into wall studs support the back of the benchtop and the outside ends, if continued to a corner. If you elect not to carry the benchtops all the way to the shop corners, build one or two end supports, shown in the illustration on *next page*. Either solution provides firm support for the countertops.

Finding wall space this long without encountering uneven spots in a concrete floor can prove difficult in some shops. To address this issue, determine the position of the base cabinets, measure up from the highest spot on the floor and mark the wall. Position the top of the wall cleat 41" from

this high spot to allow the Versa-cab base cabinets to fit beneath the countertop, as shown in the illustration. Next, draw a 48"-long level line from this mark. Then, lengthen the level line across the entire wall with a chalk line and use the mark to install the cleats on the wall. If you have a significant floor variation, you may need to adjust the height of the end supports until level with this line.

With the benchtops installed but not attached to the base cabinets, position the base cabinets and level them to maintain 27½" between the sides of the cabinets. This spacing leaves a ¾" gap between the side of the base cabinet and the benchtop side edging (C), which allows space to maneuver the miter saw platform support

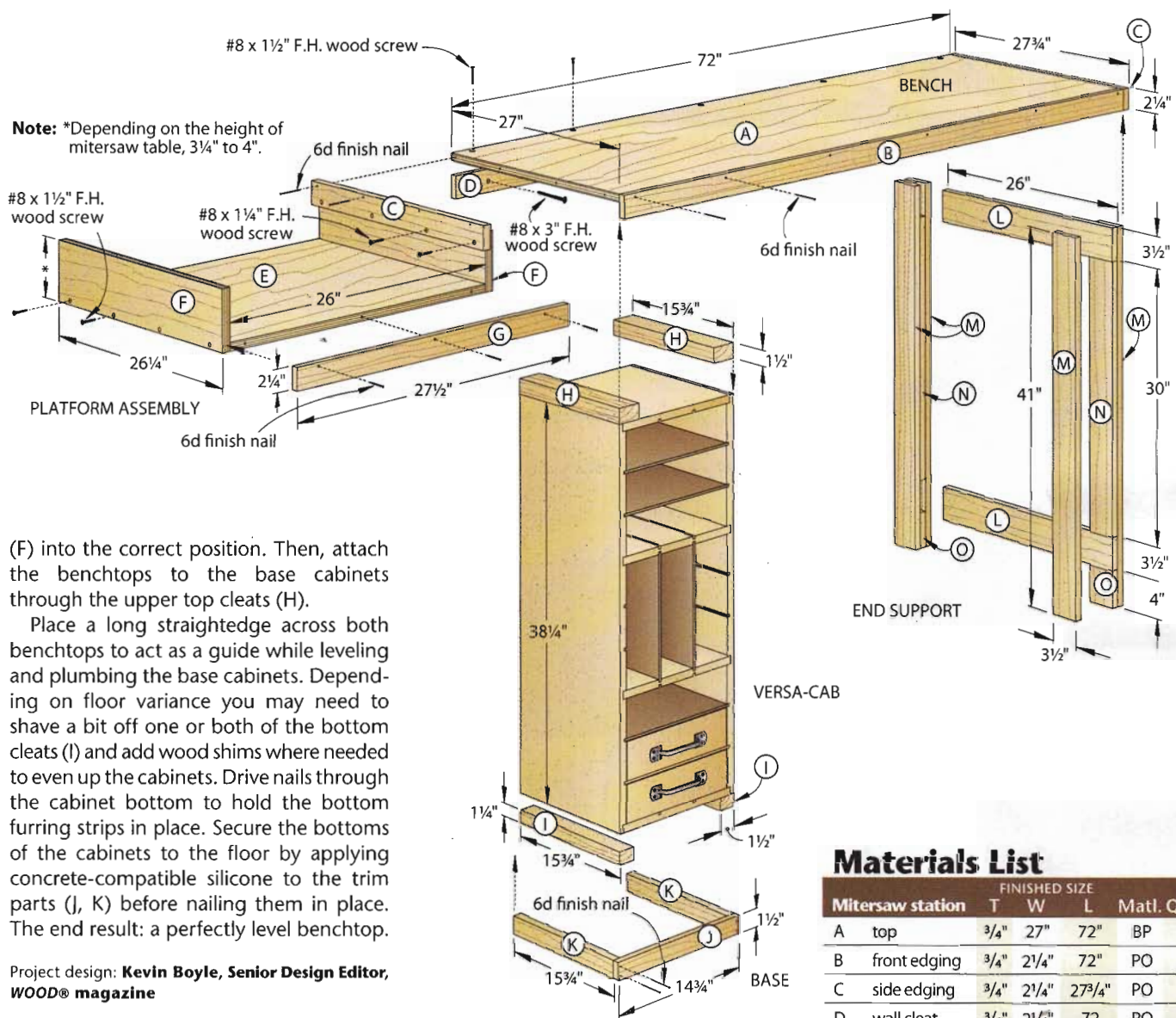

Note: *Depending on the height of miter saw table, 3/4" to 4".

(F) into the correct position. Then, attach the benchtops to the base cabinets through the upper top cleats (H).

Place a long straightedge across both benchtops to act as a guide while leveling and plumbing the base cabinets. Depending on floor variance you may need to shave a bit off one or both of the bottom cleats (I) and add wood shims where needed to even up the cabinets. Drive nails through the cabinet bottom to hold the bottom furring strips in place. Secure the bottoms of the cabinets to the floor by applying concrete-compatible silicone to the trim parts (J, K) before nailing them in place. The end result: a perfectly level benchtop.

Project design: **Kevin Boyle, Senior Design Editor, WOOD® magazine**

Materials List

Miter saw station	FINISHED SIZE			Matl. Qty.
	T	W	L	
A top	3/4"	27"	72"	BP 1
B front edging	3/4"	2 1/4"	72"	PO 1
C side edging	3/4"	2 1/4"	27 3/4"	PO 2
D wall cleat	3/4"	2 1/8"	72"	PO 1
E miter saw platform	3/4"	26"	26 1/4"	BP 1
F† platform supports	3/4"	3 1/2"	26 1/4"	BP 2
G platform edging	3/4"	2 1/4"	27 1/2"	PO 1
H* top cleats	1 1/2"	2"	15 3/4"	P 2
I* bottom cleat	1 1/2"	1 1/4"	15 3/4"	P 2
J* front base trim	3/4"	1 1/2"	14 3/4"	P 1
K* side base trim	3/4"	1 1/2"	15 3/4"	P 2
L end support crossrails	3/4"	3 1/2"	26"	P 2
M outer legs	3/4"	3 1/2"	41"	P 4
N long leg fillers	3/4"	3 1/2"	30"	P 2
O short leg fillers	3/4"	3 1/2"	4"	P 2

* Quantity for one cabinet
 † 3/4"-4", depending on miter saw table height
Materials Key: BP-birch plywood, P-pine, PO-poplar.

FIGURING THE PLATFORM HEIGHT

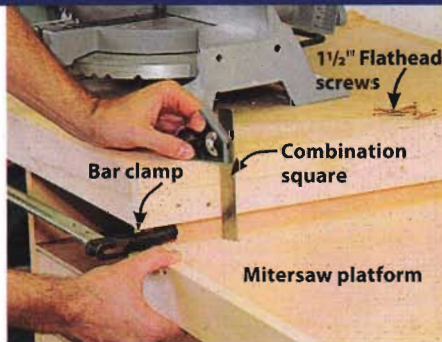
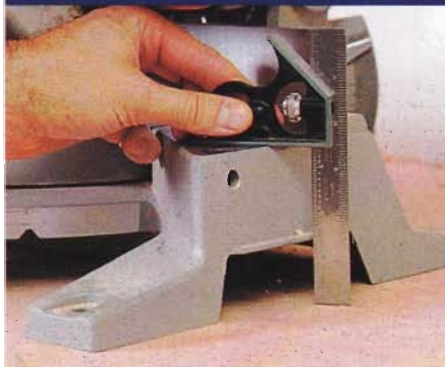

To align the miter saw table with the top surface of the adjacent benchtop, use a combination square and measure down from your miter saw table, as shown. Then, trim the width of the platform supports (F) to that measurement, less 1/4". This small gap provides adjustability for the platform positioning without sacrificing strength.

Set the depth of the front of the miter saw platform first by sliding the platform supports (F) behind the benchtop edging (C). Clamp the platform supports to the neighboring cabinet sides. Set the depth of the platform's back and screw it in place at that location. Return to the front, recheck the depth and finish screwing the platform in place. Add the miter saw and recheck the height.

On-the-level miter saw support cart

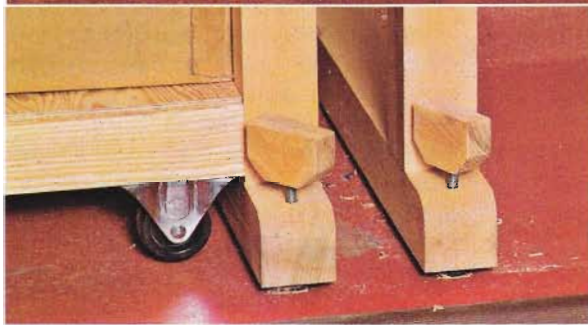

Two useful shop supports; one great idea when working as a team.

This rolling worktable and miter saw stand are great workshop supports in their own right. But when latched together and adjusted with built-in shop-made leveling devices, they join forces to create a single, solid miter saw workstation. The worktable has an auxiliary fence for use with the miter saw, but it can be slid out of the way on T-slots when the table is used independently of the saw. The simple leveling device shown in the illustration allows for both mobility and stability. Bolts extend through the feet of the table and rest on rubber pads epoxied to the bolt heads, and twisting the wooden wing on top of the bolt raises the feet off the floor. Each foot can then be lowered independently, ensuring a stable, level setting. This not only allows the worktable to be adjusted perfectly flush when used with the miter saw but also can compensate for uneven floors elsewhere in the shop.

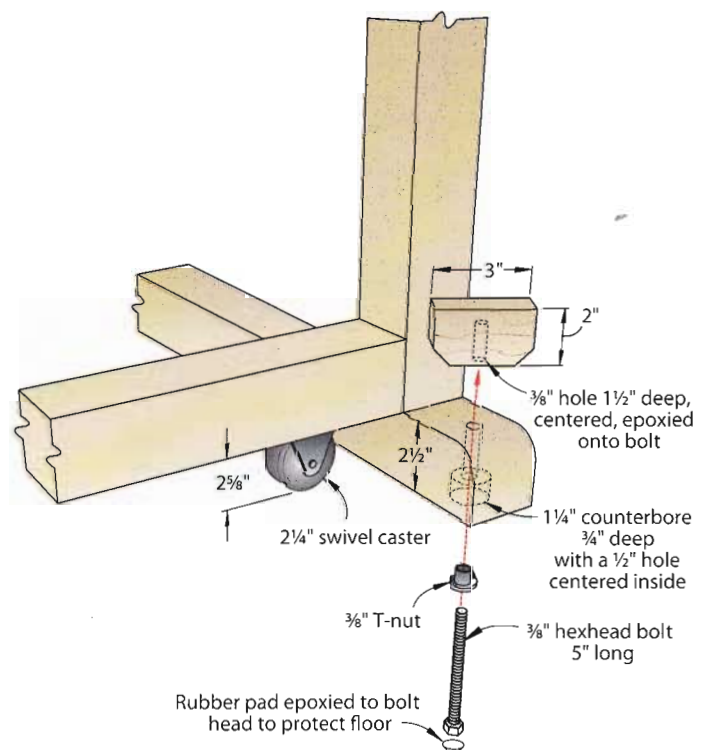

Project design: **Fred Collins, South Duxbury, Vt.**

Zero-clearance miter saw fence

If a replaceable insert can help prevent tear-out on a tablesaw, why not on your miter saw, too?

Mitersaws come out of the box with standard metal fences that work fine. But this shop-made fence with replaceable blocks makes repetitive cuts easier and cleaner than with the original metal fence. Making it possible is a 3/4"-high, zero-clearance auxiliary fence servicing the saw. With solid wood behind your workpiece, you'll get the cleanest cuts possible.

Project design: **Scott Beresford, Pittsburgh**

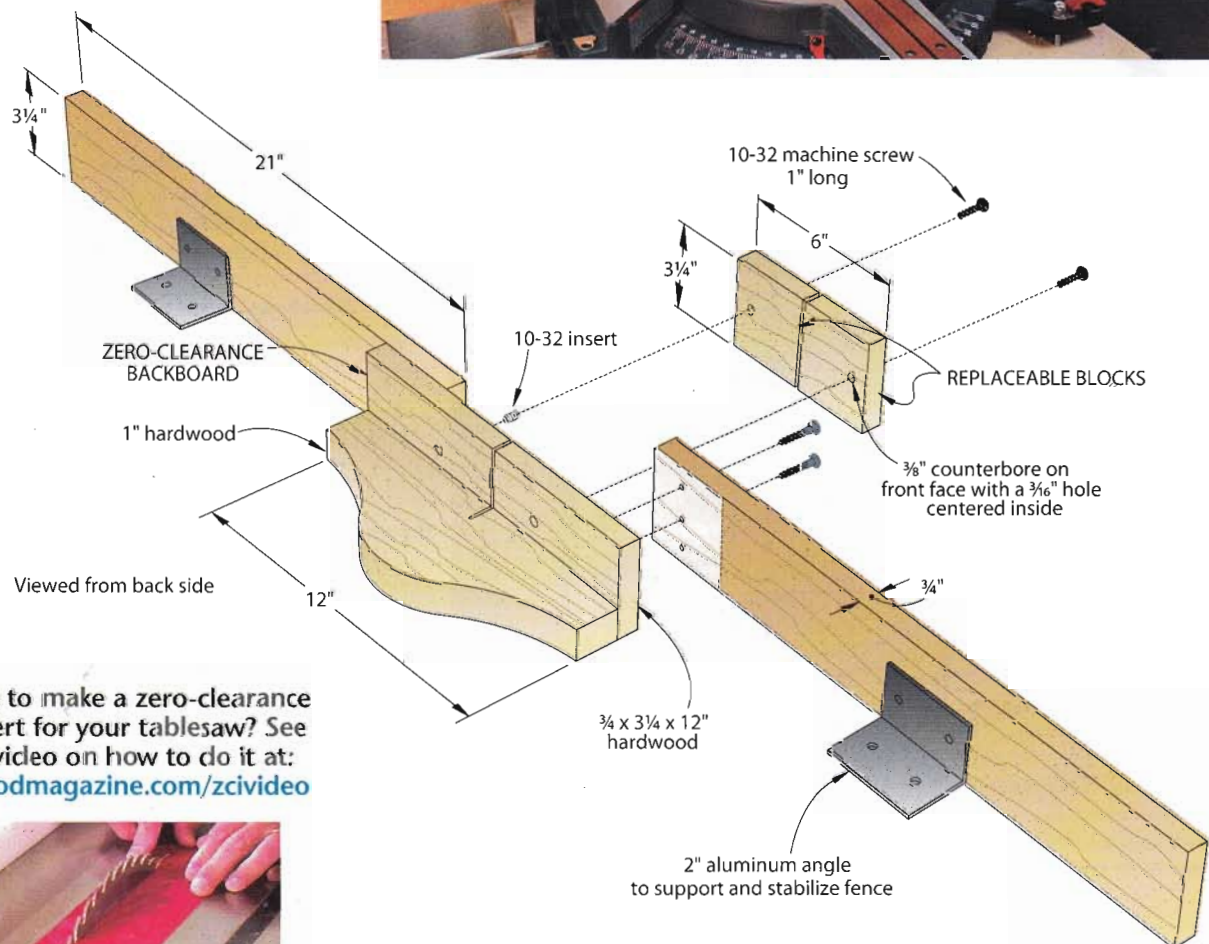
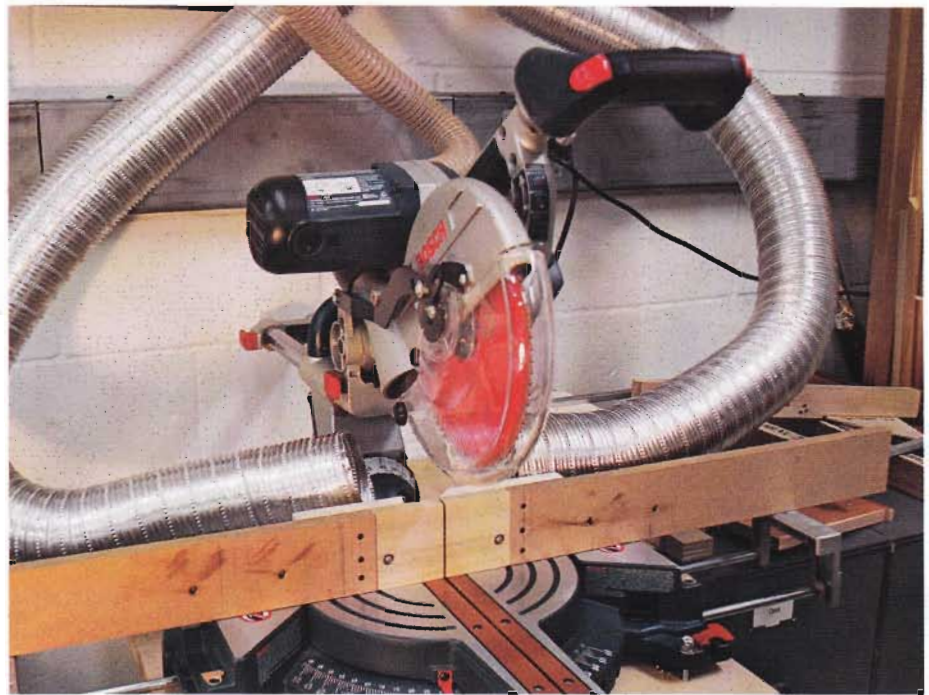

Like to make a zero-clearance insert for your tablesaw? See a video on how to do it at: woodmagazine.com/zcivideo



Mitersaw dust-collection hood

A better alternative to the standard dust bag.

The zippered dust-collection bag that comes with a mitersaw tries hard to collect the chips spewing from the saw's dust port, but it's just no match for a dedicated vacuum system like this one. The hood keeps chips contained, directing them to the 4" port mounted flush in the saw's support platform. A branching pipe below the table connects to a separate small hose that can be used for general cleanup of the area around the saw. A pair of rods, shown in the illustration below, open and close the blast gates for each dust port.



Project design: **Dave Estopinol, Oak Glen, Calif.**

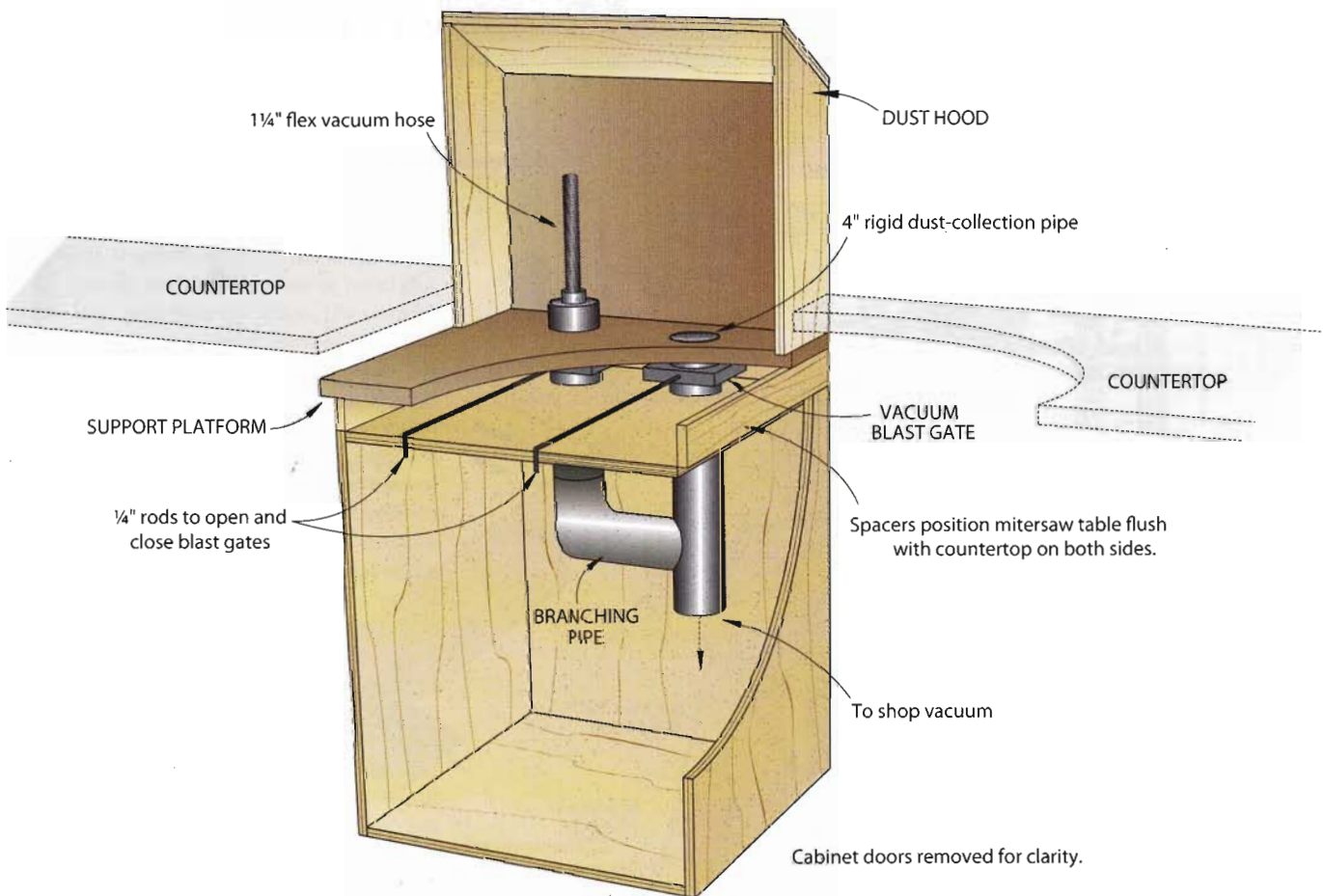

Back-to-basics **worktable**

Quick and easy to build, this simple work surface offers plenty of wide-open space.

A table doesn't have to be fancy to get the job done, as this expansive workhorse proves. An easy weekend project, the base consists of 2x4s and 2x6s bolted and screwed together for rock-solid construction. The top, made of two layers of $\frac{3}{4}$ " plywood laminated face-to-face and covered with a sheet of plastic laminate, offers an attractive, stable work surface that's easy to clean. Solid-wood banding around the edges of the worktop protects the edges, hides the plies, and adds the perfect finishing touch.

Project design: **Leland Frerichs, Longview, Wash.**

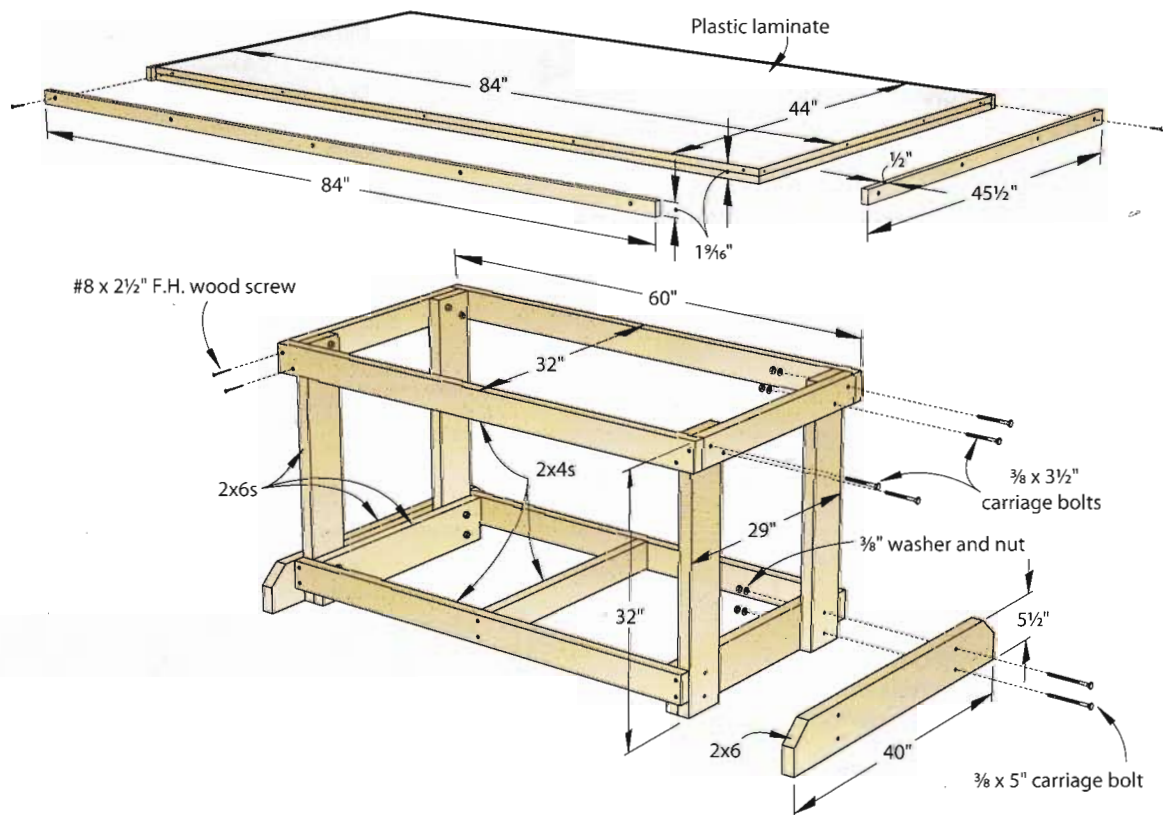

Pipe clamp support U-blocks

Controlling pipe clamps is easy with a little help from your workbench's dog holes.

You can hold pipe clamps securely during panel glue-ups with these doglike U-blocks. To make a matching pair, first cut a 1½"-thick piece to 3x3" as shown in the Cutting/Drilling Diagram [Drawing 1]. Then, drill the centered dowel holes on opposite edges. Drill either a ¾" or 1" hole (based on the diameters of pipes) through the center of the face of the block.

Cut the blocks in half where shown, and then cut and glue in dowels sized to fit the dogholes in your benchtop [Drawing 2]. During use, place a pair of U-blocks under each pipe, as shown at *right*.

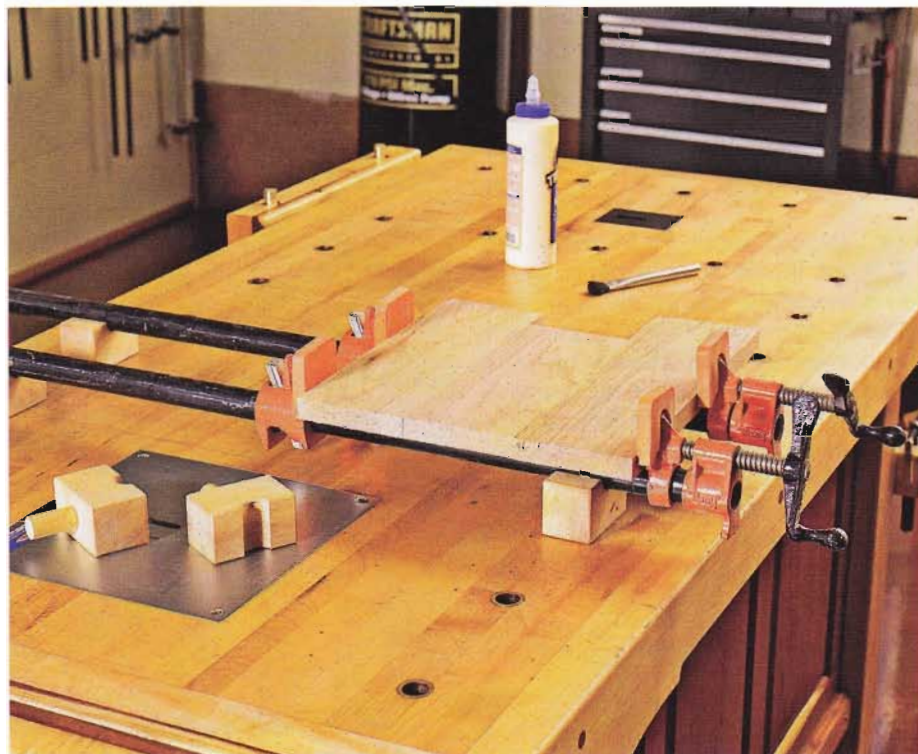

Project design: **Rod Cox, St. Paul, Iowa**

1 CUTTING/DRILLING DIAGRAM

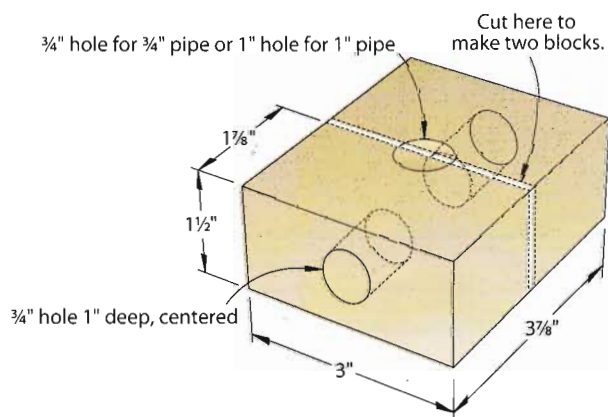

2 U-BLOCK ASSEMBLY

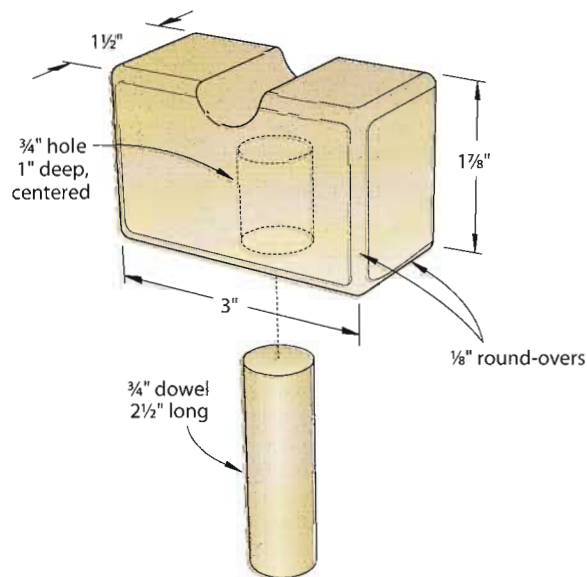

Learn the tricks for clamping up perfect, flat panels at:
woodmagazine.com/panels



Tilt-and-go tool bins

Getting more done is easy when your portable power tools are close at hand.

Any workbench or assembly table instantly becomes more efficient by adding these convenient tilt-out storage bins for portable power tools. A power strip mounted along the edge keeps tools plugged in and ready for service, even while stowed away, and slots at the top of each bin accommodate the cords. A single length of galvanized pipe acts as the pivot point for all five bins.

Project design: **Dave Estopinol, Oak Glen, Calif.**

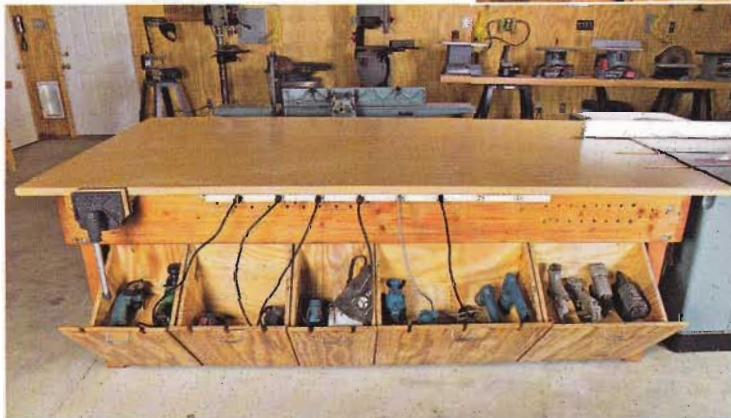

1a SIDE VIEW DETAIL

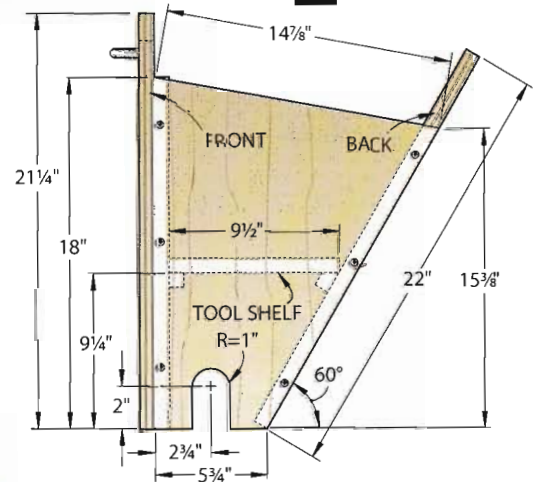

1 EXPLODED VIEW

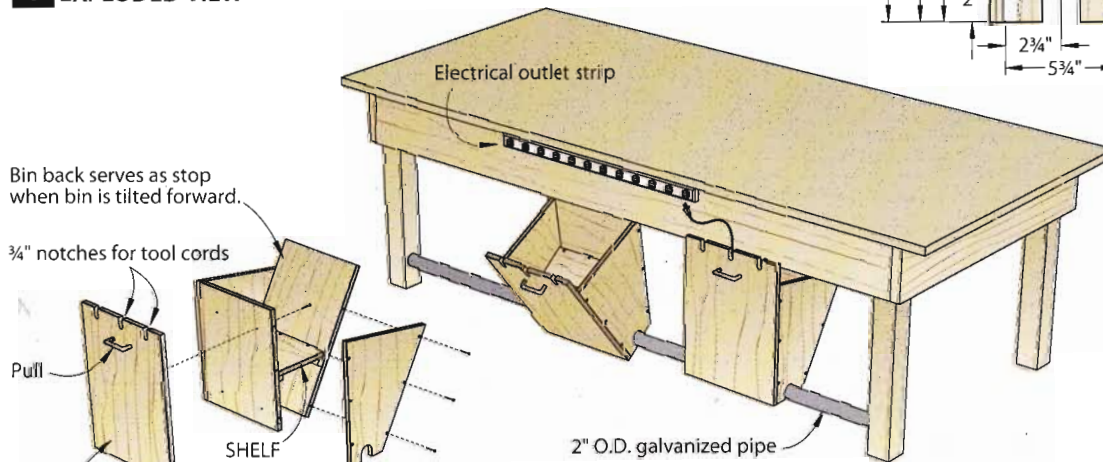

Note: Size bins to fit your workbench.

Bolt-on drill-press table

Get some much-needed stock support with this easy add-on table.

Simple but effective, two carriage bolts hold this medium-density fiberboard (MDF) worksurface to the machine's existing table, while a pair of clamps secures its fence. To build one for your drill press, simply make whatever modifications you need to fit one over your model's table.

Project design: **Paul Amberg, Hubertus, Wis.**

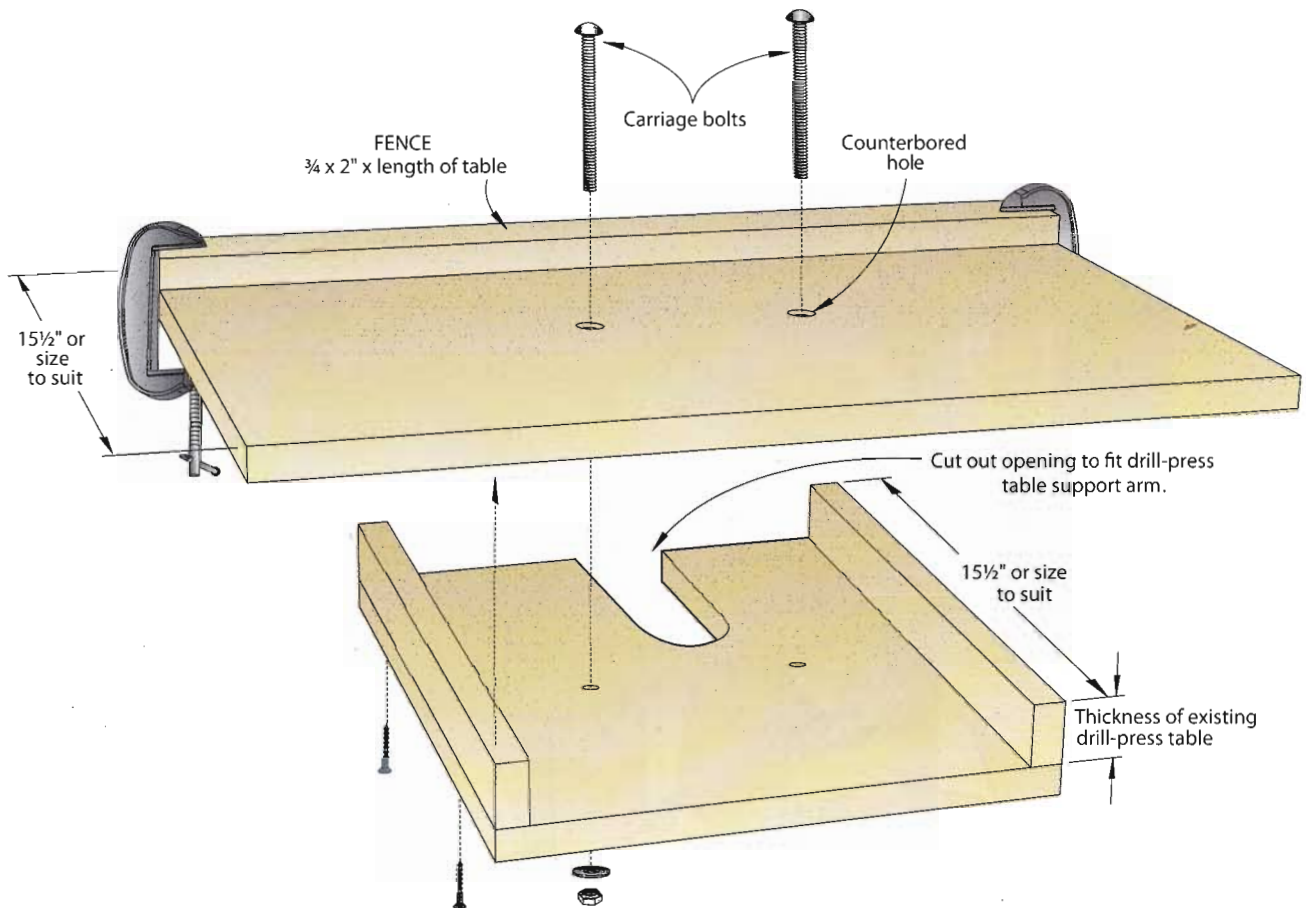
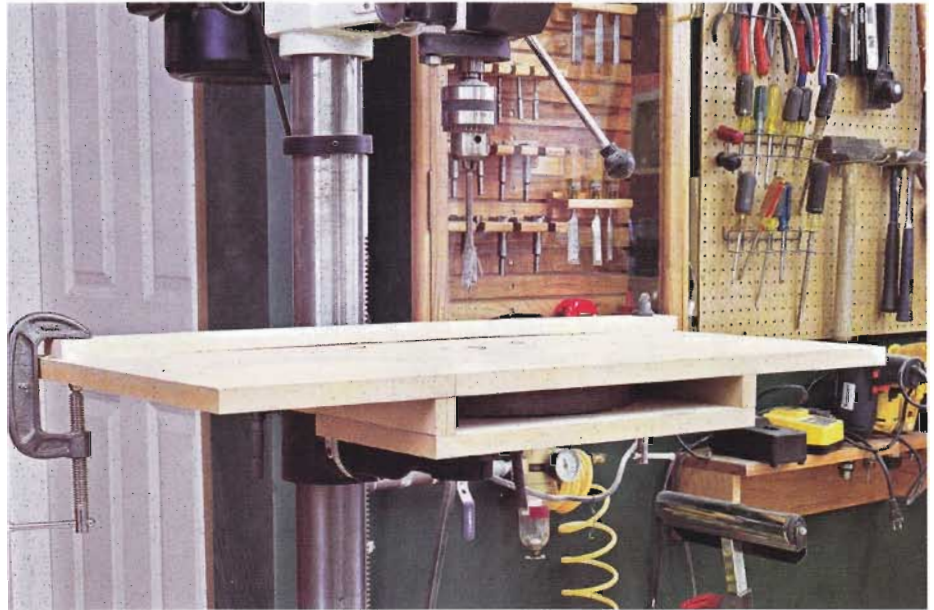

Rotating sharpening station

Chisels and gouges—and the means to sharpen them—are never far away with this rotating stand.

Build this project for next to your lathe, workbench, or carving center and you'll never have to reach for your tools or the grinder to sharpen them again. The rotating top has chisel-mounting holes on three sides and a grinder on the fourth, so everything you need is just a spin away. A thin sheet of ultra-high molecular-weight (UHMW) film lets the top spin freely, or you could substitute a lazy-Susan mechanism. Additional supplies store out of sight behind a frame-and-panel door.

Project design: **Walt Segl, Pleasant Valley, Pa.**

Find more shop project plans at: woodmagazine.com/freeplans

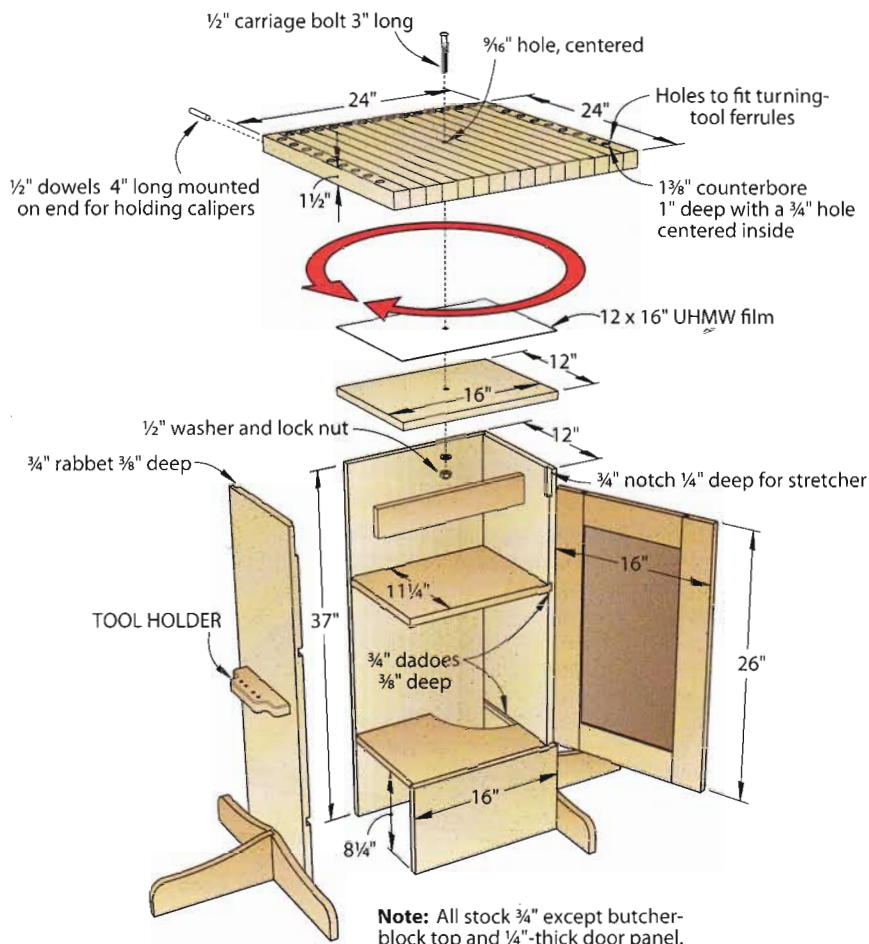
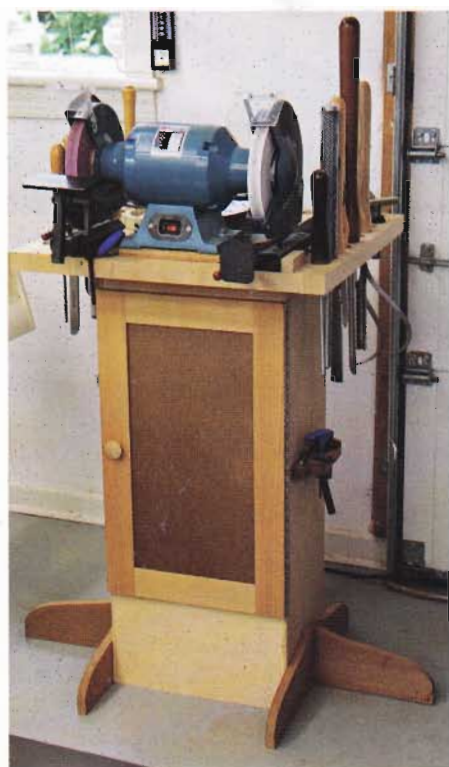

Orbital sander cradle

Customize this basic design to support your machine.

Shop time should be measured in both quality *and* quantity. And although the few seconds it takes for a 5" random-orbit sander's pad to quit spinning doesn't amount to much, it sure can be a nuisance when you want to put the sander down. The chamfered bottom edge of the hole in the top of this sander cradle traps the sander in the opening to keep it in place as it spins down. A rear-mounted upright catches the sander's dust-collection bag or canister to keep the sander from spinning. For sanders with a vacuum attachment, like the one at *lower right*, add an optional side support. This holds up the vacuum hose to keep the sander from tipping over. Drill a 1" hole in one side of the base to hang the sander cradle when not in use.

Project design: **Chuck Hedlund**, *WOOD®* magazine Master Craftsman

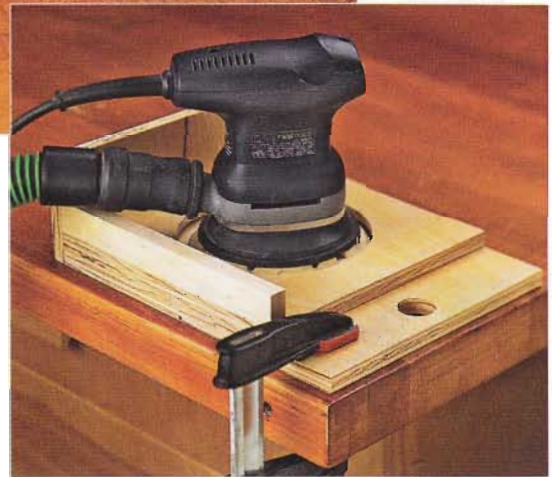

The optional support at *right*, works well for the vacuum hose to rest on, preventing the sander from tipping over.

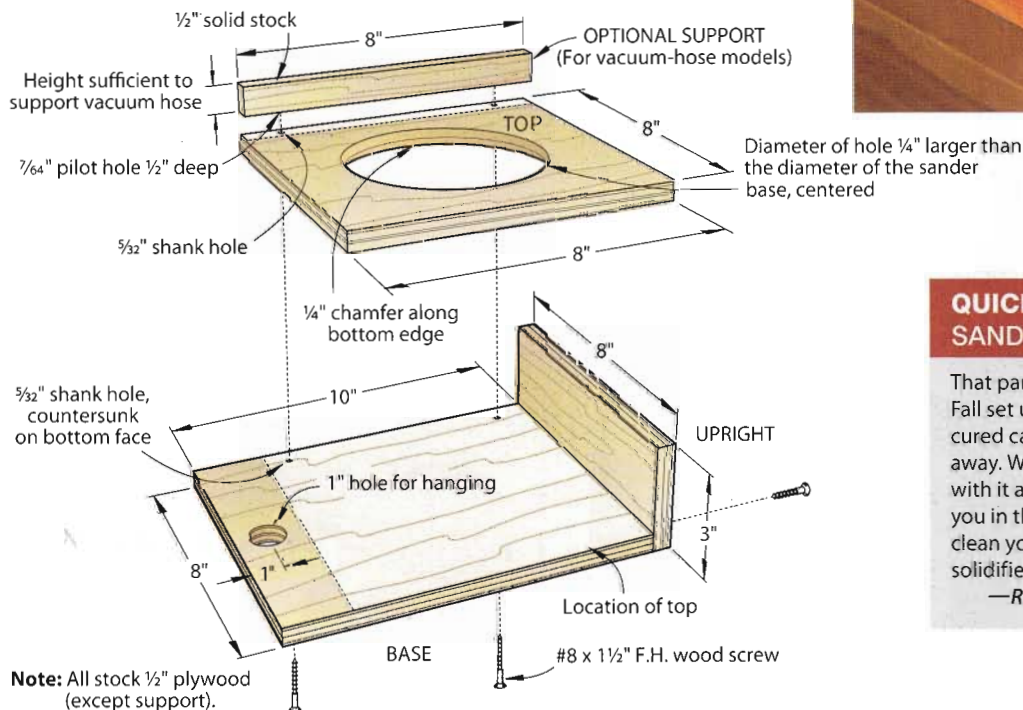

QUICK TIP: SANDPAPER CLEANER

That partial tube of silicone caulk from last Fall set up. Now you have a big chunk of cured caulk that you may as well throw away. While you can't stop drafts and leaks with it any longer, that caulk can still serve you in the shop. Strip away the tube and clean your abrasive belts or discs with the solidified silicone.

—Robert Thompson, Buckeye Lake, Ohio

Inverted sander stand

This hands-free holder works great for sanding small parts.

To sand difficult-to-hold components efficiently, you sometimes need to use both hands. This stand firmly holds your sander upside down, freeing your hands for more effective control of the part being worked. The slots holding the sander are tapered on the sides for a good grip. When sizing the slots for your sander, it's best to make them slightly on the small side at first, then enlarge them gradually until you get a snug fit. A clamp secures the stand to the bench.

Project design: Tom Clark, Sarasota, Fla.

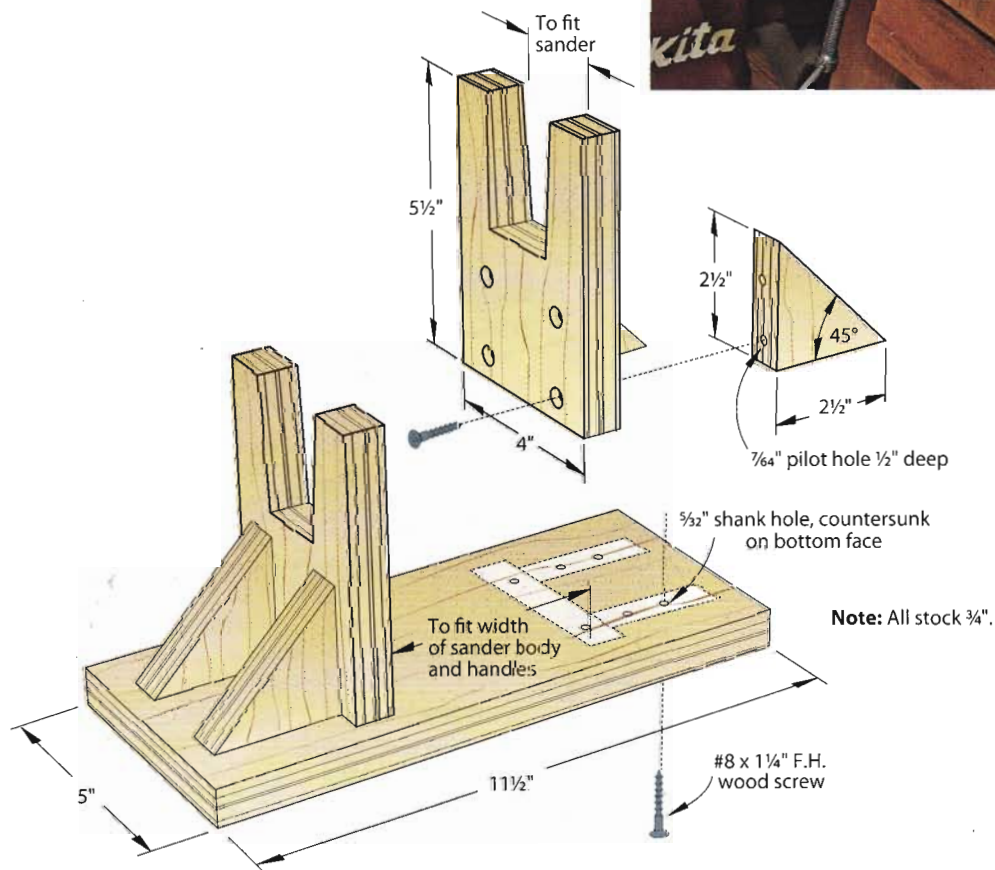
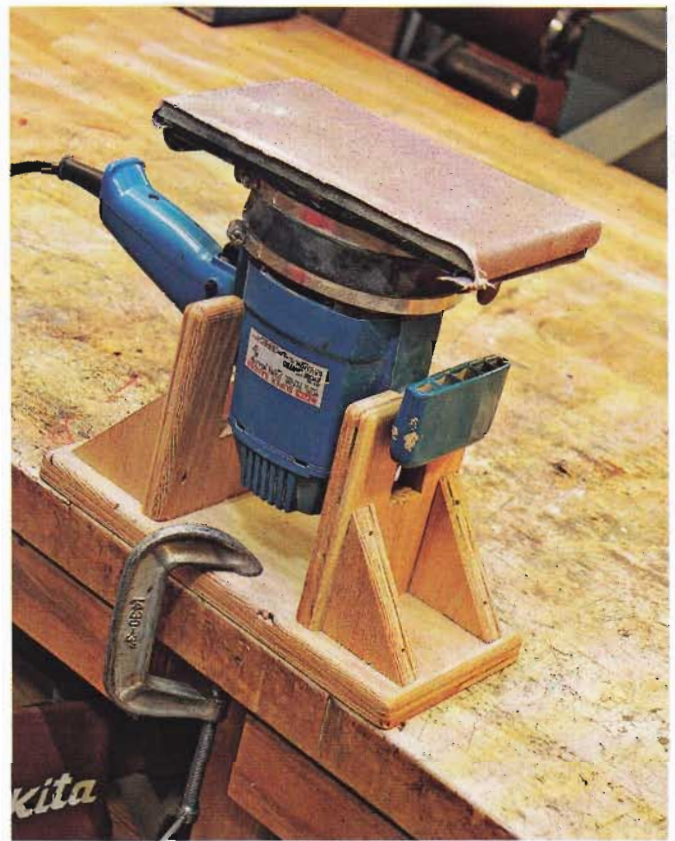

at-the-ready router rest

This simple support offers you convenience and time savings for handheld work.

Wasting valuable time waiting for your router bit to stop spinning before you can set the router down? Would you like your router wrenches and bits near the project you're working on for a speedy change? Address both concerns simultaneously by building this handy plywood router rest. Place your powered-down router in the U-shaped opening in the shelf support to shelter the still-turning bit safely away from both your worktop and your hands.

To build this simple project, cut the pieces to the sizes noted on the drawing below right. Then, cut or rout a $\frac{3}{4}$ " groove $\frac{1}{4}$ " deep in the side pieces where shown. Drill the router-bit shank holes, and cut the kerfs in the base to customize it to organize your bits and wrenches. Drill countersunk mounting holes and assemble the pieces. A short section of dowel in the base works nicely to hold an extra collet. Add a clear finish, if desired.

Project design: **Chuck Hedlund, WOOD® magazine Master Craftsman**

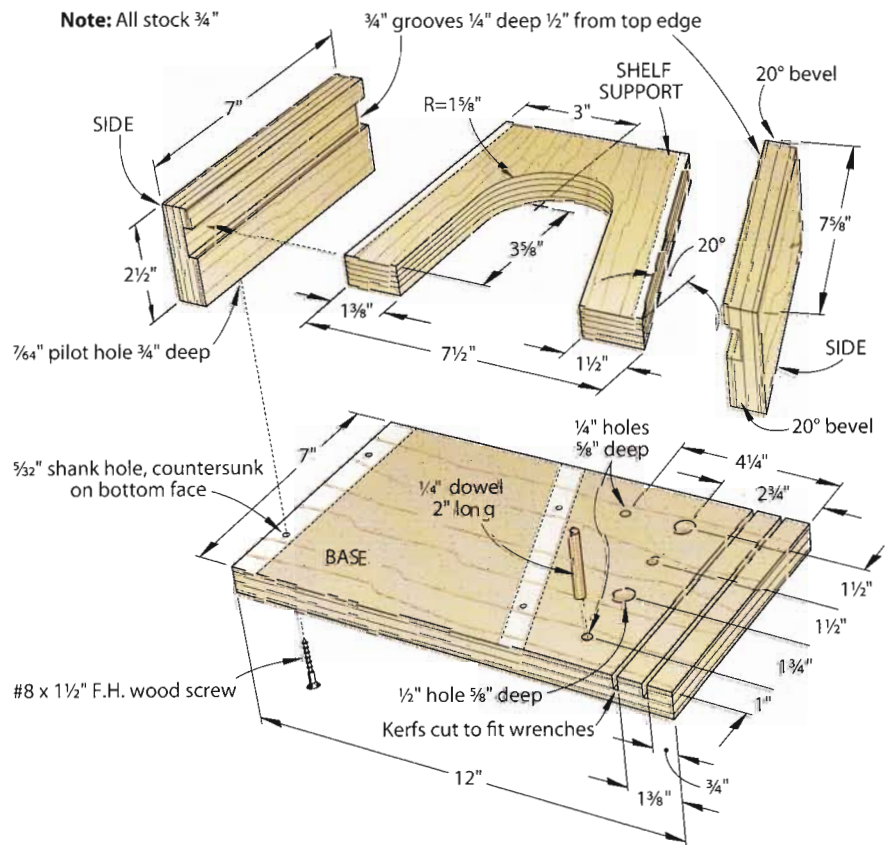

Become an expert at the router with our collection of how-to videos at: woodmagazine.com/routertips



Right-height **outfeed support**

Versatile and effective, this handy extension adapts to fit a variety of shop machines.

Here's a solid but adjustable solution to stock support. Mount it to a workbench, as shown, or add legs for a stand-alone support. Easy height adjustability makes it a versatile addition to any woodworking shop.

We used $\frac{3}{4}$ " MDF for most of the construction and laminated two pieces of $\frac{3}{4}$ "-thick stock to form the movable post (F). The beveled support pad (H) allows stock to move over it with ease.

When assembling the unit, note that only the bottom end of the sleeve front (B) is screwed in place, allowing the top of B to flex. This enables you to lock the post (F) in place in the sleeve assembly (A/B) using a four-arm knob, pressure block (C), and a steel mending brace.

Project design: **John Lanigan, Concord, N.H.**

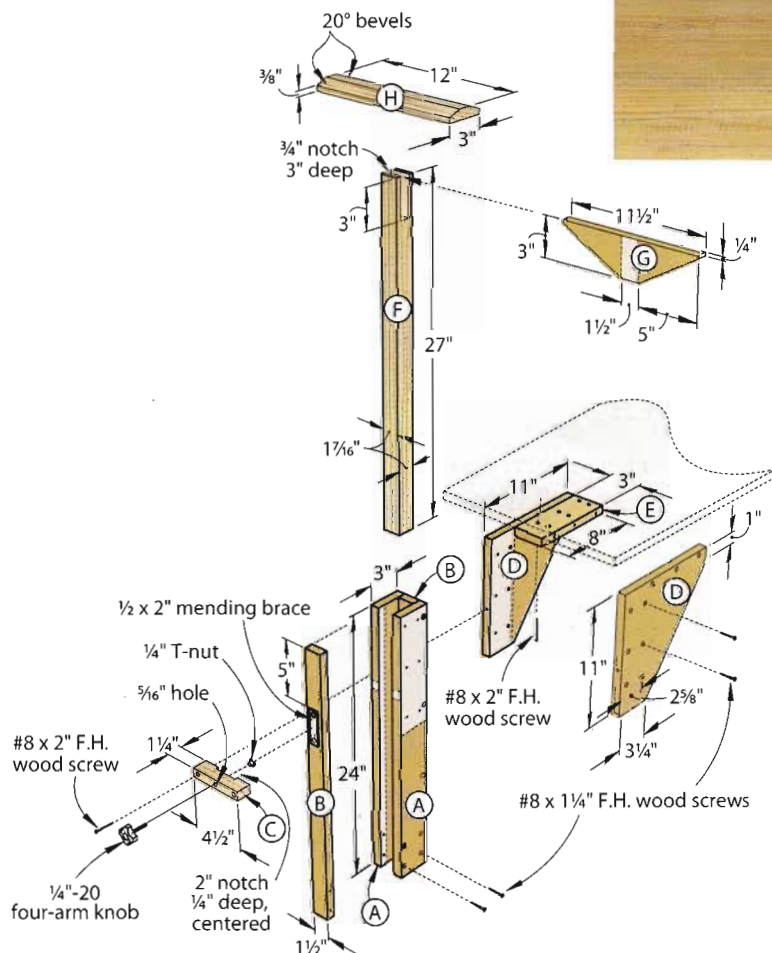

Materials List

Part	FINISHED SIZE			Matl.	Qty.
	T	W	L		
A sleeve sides	$\frac{3}{4}$ "	3"	24"	MDF	2
B sleeve front/back	$\frac{3}{4}$ "	1 $\frac{1}{2}$ "	24"	MDF	2
C pressure block	$\frac{3}{4}$ "	1 $\frac{1}{4}$ "	4 $\frac{1}{2}$ "	P	1
D bottom braces	$\frac{3}{4}$ "	11"	11"	MDF	2
E bottom bracket	$\frac{3}{4}$ "	3"	8"	MDF	1
F post	1 $\frac{1}{16}$ "	1 $\frac{1}{16}$ "	27"	P	1
G upper brace	$\frac{3}{4}$ "	3"	11 $\frac{1}{2}$ "	MDF	1
H support pad	$\frac{3}{4}$ "	3"	12"	P	1

Materials key: MDF—medium-density fiberboard, P—pine.

Supplies: #8x1 $\frac{1}{4}$ " flathead wood screws, #8x2" flathead wood screws, $\frac{1}{4}$ "-20 four-arm knob (1), $\frac{1}{4}$ " T-nut (1), $\frac{1}{2}$ x2" mending brace National N114-314 (1).

Movable task-light support

Let there be light wherever you want it with this cleat-mounted vision aid.

For maximum efficiency in wall-mounted storage, a cleat system is hard to beat. Strips of 1x3 stock beveled at 45° at the top and anchored to the shop walls mate with matching strips attached to just about anything from cabinets to tables for easy wall mounting. This easy-to-build light support fits and locks onto the same cleat for placement wherever it's needed.

To make this shop helper, cut the cleat and the turnbutton from solid stock and the shelf, bracket, and back from 3/4" plywood. Drill countersunk screw holes and a hole in the shelf to fit your light's mounting post. The bottom edge of the back must be flush with the bottom edge of the wall-hung cleat when in place. Adjust if needed. Glue and screw the support together and then position the assembled light support where you need it. Drop the light into place in the hole and swivel the turnbutton, as shown in the photo below, to secure the support to the wall cleat.

For use in a shop without a cleat system, construct the project so the shelf's rear edge is flush with the rear surface of the back. Omit the turnbutton and cleat, and screw the assembled support to the wall, centered over a stud. Then, slip the lamp extension into the hole in the shelf.

Project design: **Kevin Boyle**, *WOOD*® magazine Senior Design Editor

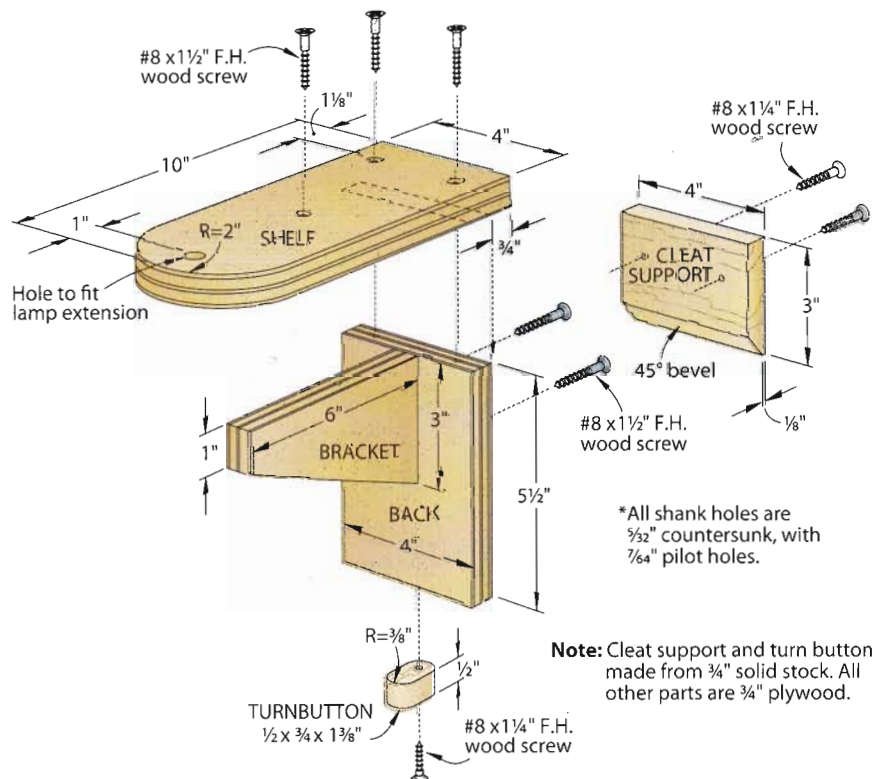

Telescoping-top router table

Easily stowed when in the lowered position, this routing station rises to the occasion when needed.

When Jim Treece needed a router table, he quickly discovered he didn't have room in his garage shop for another large stationary cabinet. His solution was a telescoping table that slides down to fit under a work counter when not in use.

First, build the base to your desired dimensions so the entire assembly will fit under the counter. (The dimensions shown should work in most situations.) Cut 1/4"-wide slots as shown in the table sides for the telescoping function. The slots have an L-shape at the bottom to help stabilize the table when it's in the working position. Use T-knobs, carriage bolts, and locking washers to secure the sides to the base.

Project design: **Jim Treece, Knoxville, Tenn.**

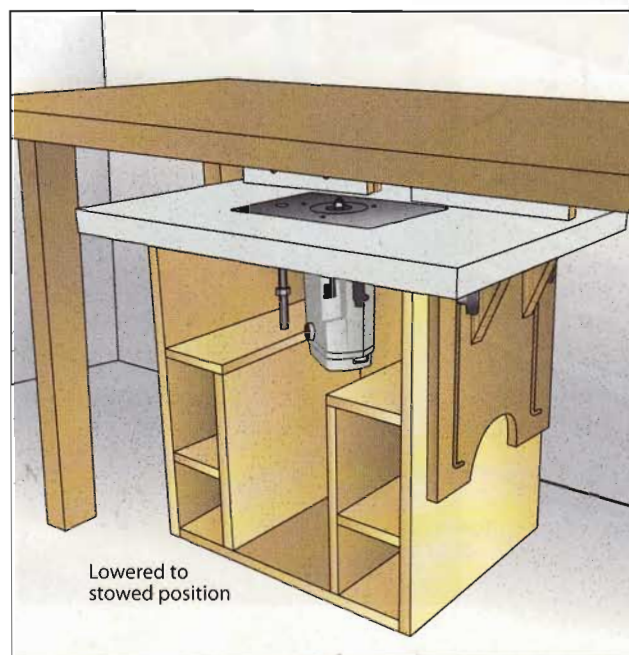
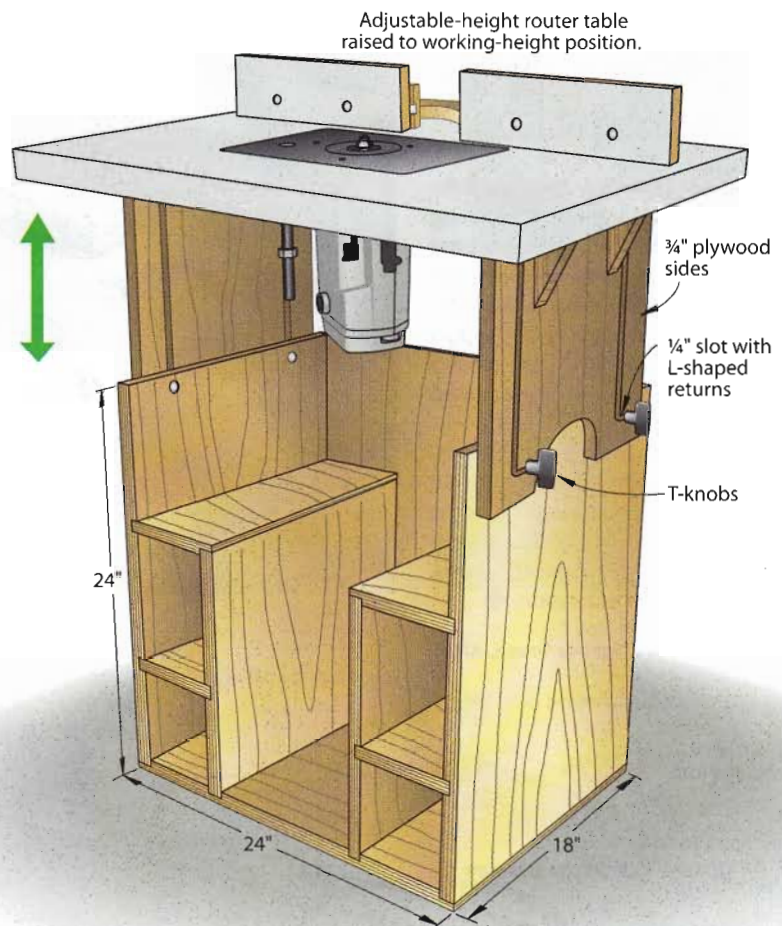

QUICK TIP: FIGHT UNDER-TABLE DUST

A table-mounted router can suck in a lot of sawdust under the table. To help it breathe a little cleaner air, affix a bag-type painter's strainer to the top of the router's motor housing. Cut a hole for the cord and secure the bag to the router with a wide rubber band. It helps to drop a small piece of scrapwood into the nylon-mesh bag to keep it extended. Shake or vacuum the dust off the bag occasionally so it won't clog and cut off air flow.

—Bruce Buckingham, Mt. Pleasant, Iowa

Torsion-box **mobile base**

Sturdy, strong and mobile, this rolling platform can take on even the heaviest tools.

Made of medium-density fiberboard (MDF) with 4" locking swivel casters, this movable base can be adapted to any shop machine. For heavy machines—like the 500-lb tablesaw shown here—MDF alone can't support the weight. The answer is to construct a torsion-box subbase out of solid wood that attaches beneath the MDF platform.

The tablesaw rests directly on the subbase because it protrudes through a cutout in the MDF platform sized to exactly fit the saw. The extra length of the mobile base is perfect for constructing a drawer cabinet beneath the saw's right extension. 

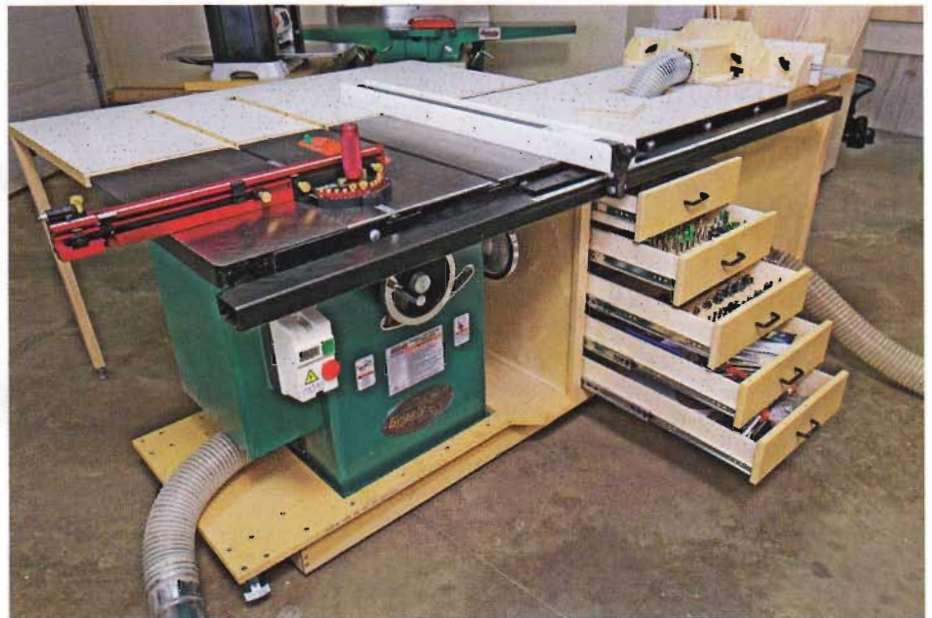

Project design: **Jeff Tobert, Spruce Grove, Alta.**

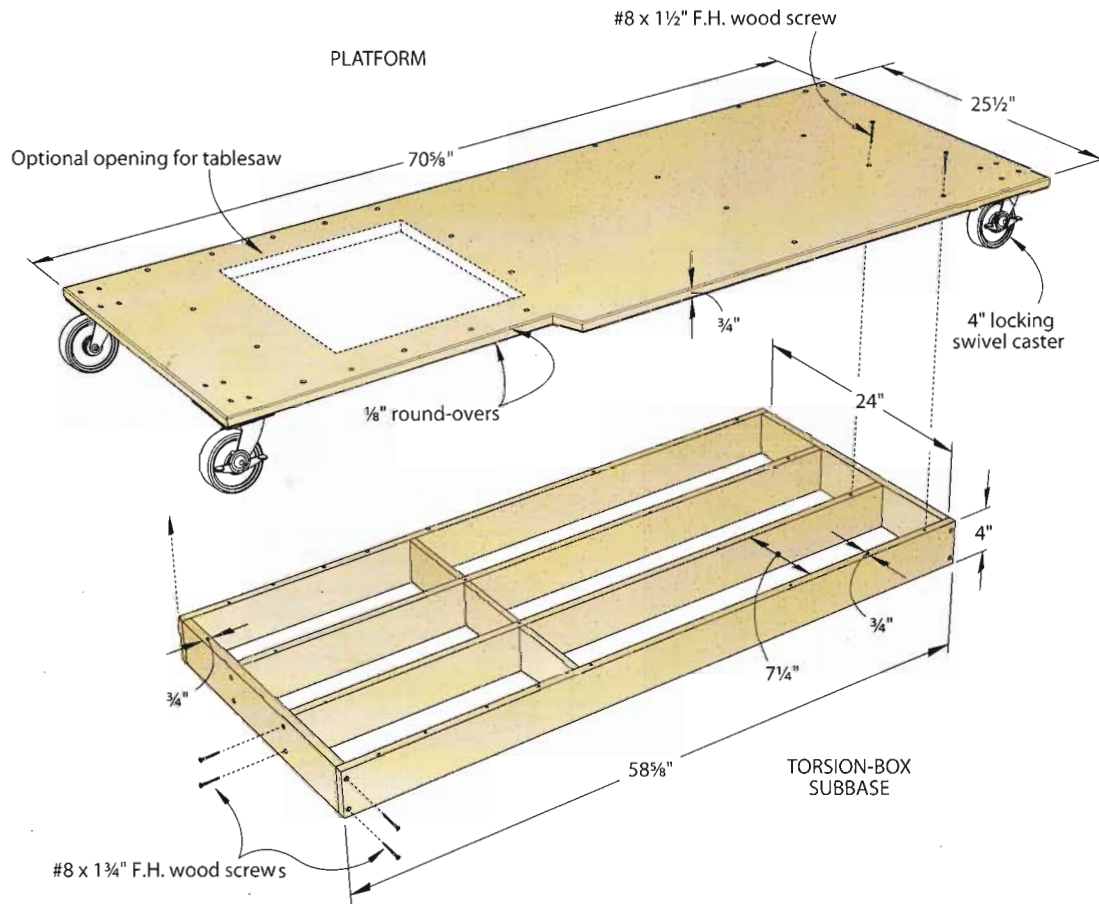

The Great **WOOD**® Magazine Book Offer!

Buy 2 or more **WOOD** books and get **365+ Great Shop Tips** **FREE!**

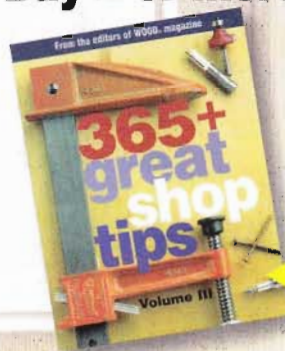

These top-selling books from the editors of *WOOD* magazine offer in-depth information that will help you master many woodworking fundamentals and give you endless project ideas. You'll find professional advice, tips, charts, tables, diagrams, plans, patterns, and much more. A must-have for woodworkers of all levels.

FREE 365+ Great Shop Tips brings you woodworking wisdom from clamping to sawing and sanding to finishing. All tips are illustrated to clearly show how this shop-proven information can be put to use in your shop, saving you time, money, and materials. (a \$12.95 value) **FREE!**

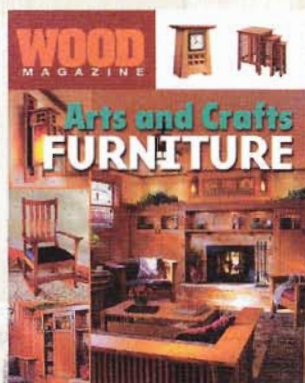

Helpful information on appropriate joinery, hardware, and finishes; plans for 16 classic projects; and an Arts and Crafts room makeover.

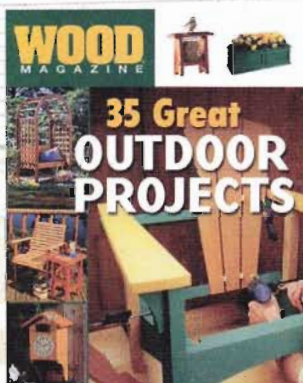

From birchhouses, feeders, mailboxes, and planters to arbors, benches, chairs, and tables, it's all here. Learn to build projects that last and last in the elements.

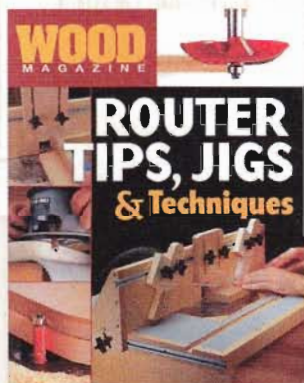

Everything you need to master the router and router table. Safely make clean cuts using shop-made jigs and today's most innovative and interesting bits.



Get just the finish you want by prepping the wood correctly and choosing the products and application methods that yield can't-fail results.

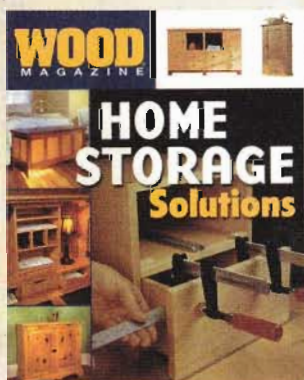

Discover key storage strategies and learn to build 19 storage projects from cabinets to shelving to display cases.

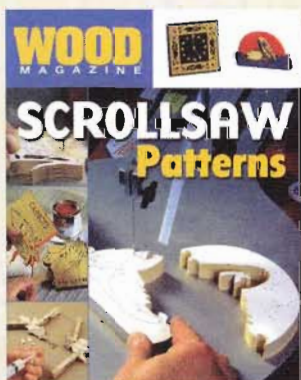

Learn the basics of scrollsawing and apply them in cutting any of these 50+ patterns for fun and practical projects.



Find plans for more than 30 charming boxes that store every trinket and treasure imaginable.

All books are full-color, from 176 to 192 pages, and sell for \$19.95 each.

Order your books today!

woodmagazine.com/woodbooks or call **1-888-636-4478**

Racks for Tools, Clamps, and Lumber



A PLACE FOR EVERYTHING For your woodworking shop to operate both efficiently and safely, an uncluttered work environment is essential. Here are 22 clever and effective ways to create accessible homes for your wood, tools, and shop equipment.

Modular lumber rack

This two-module rack keeps boards and panels out of the way but always within arm's reach. Modular design gives true size-it-to-fit versatility.

You might think that a woodworker who is also a book author and a teacher would need three full-size shops. But Paul Anthony's shop is just a converted one-car garage. "With space at a premium, organization and efficiency are key," he says. With that, Paul designed this modular rack to keep things running smoothly as he works.

stretchers to the posts. If your shop floor isn't perfectly flat, you can level the base with shims or add levelers to the foot blocks. Finally, find a good location in your shop for a pair of these modules and start loading them up.

Project design: **Paul Anthony, Rigelsville, Pa.**

A modular rack for loads of lumber and plywood

"The system keeps heavy lifting to a minimum," says Paul. "The wood travels in a straight line from the truck to the rack to the tablesaw." His rack consists of a pair of individual 6'-tall modules connected only by the boards and sheet goods supported on the arms and bases. Spaced 2' apart, they can easily handle 8'-long panels and 10'-long boards.

The freestanding design can be placed anywhere, plus it allows you to stack wood on both sides. Smaller stacks translate into less shuffling when you want to get to that bottom board.

Constructing the rack

Note that each storage module consists of two support trees connected by four long side stretchers. (See illustration at *right*.) Paul made the vertical posts from poplar, but you can substitute kiln-dried 2x4s. Be sure to use 3/4" plywood for the arms for maximum strength. Rough-cut the arms and then jigsaw or bandsaw them to shape.

With the parts cut, assemble the modules. Position the posts side by side and use a framing square to lay out the arm spacing. Now assemble these support trees. Glue and screw the arms to the posts to ensure they don't sag under load. After building the support trees, attach the side stretchers and feet with screws. To allow future disassembly, don't glue the side

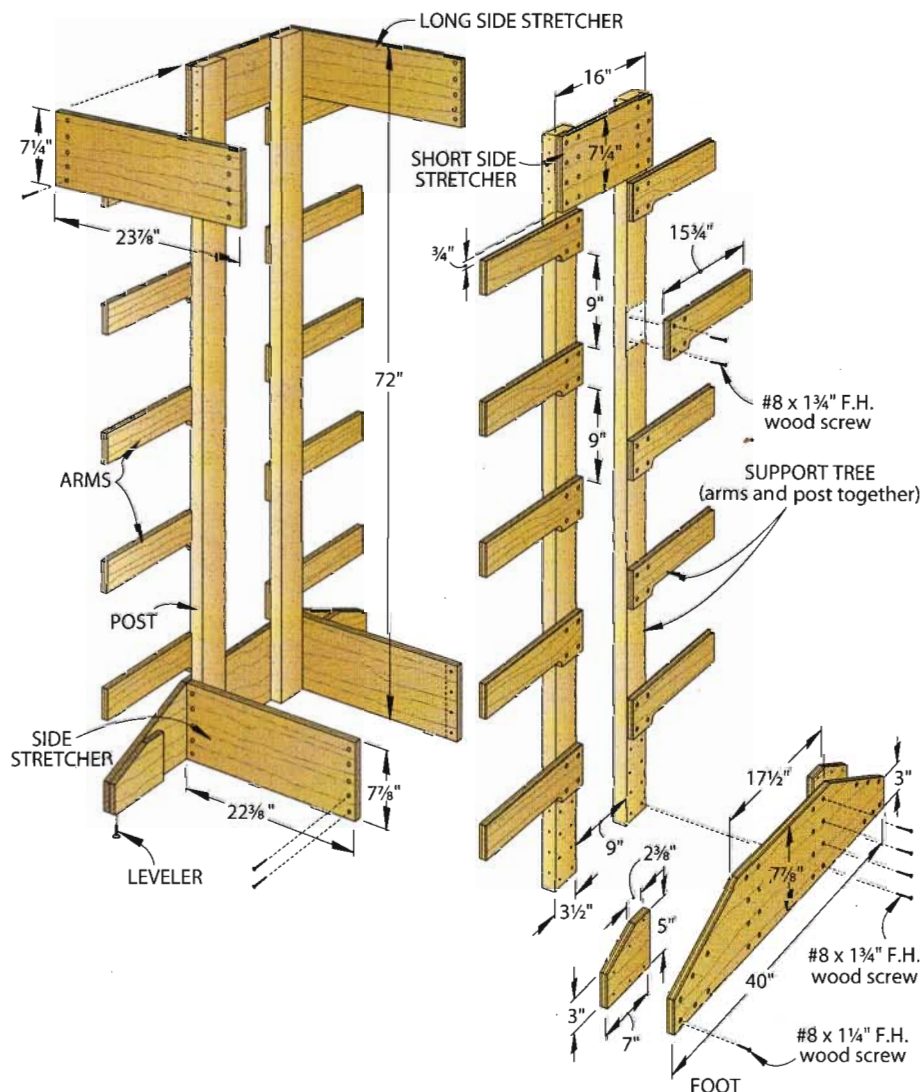

Mobile sheet-goods rack

With multiple sections, this rack makes it easy to find the right piece.

Plywood and other sheet goods populate this mobile rack, with sides tilted at 5° and each section separated by size. The shelves support smaller pieces; the middle divider not only supports larger sheet goods but also separates front from back. A set of four 5" swivel casters makes it an easy task to move even larger sheets around the workshop.

Project design: **Tom Whalley, Urbandale, Iowa**

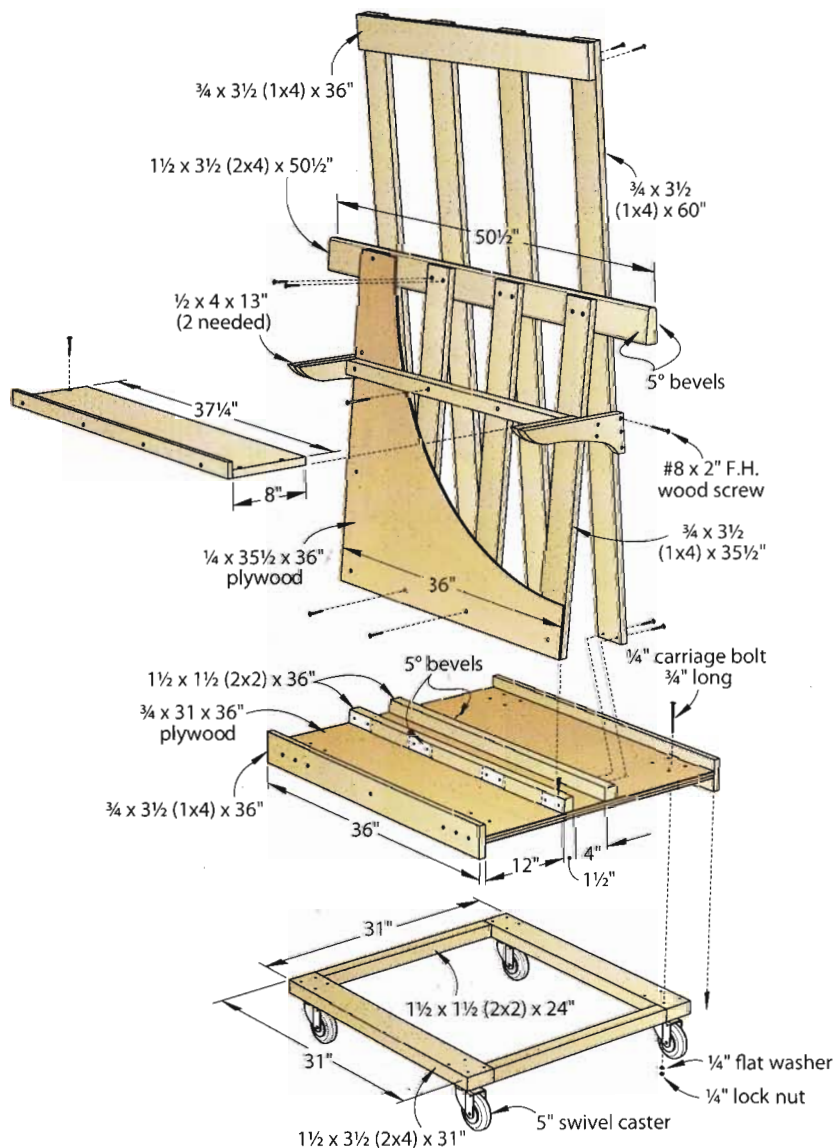

QUICK TIP: PREVENT LUMBER WARPING

Freshly resawn or planed stock will certainly warp when allowed to lie facedown on a flat surface for as short a time as one hour (even faster in very dry climates). Moisture escapes from the exposed face of the board at a faster rate than from the side facing down. To prevent this stand the piece(s) on end in a lumber rack like the one in this project—or even just lean them up against the wall—so air can flow along all surfaces. Leaving the wood this way overnight allows the stock to restabilize.

—From the WOOD® magazine shop

Wall-hugging sheet-goods holder

Taking up a strip of floor space less than 8" wide, here's a holder that won't get in the way.

Shops need a place to store sheet goods, including sheet-good scraps. However, many basement and garage shops have limited ceiling room, requiring some special considerations. To meet that need, consider going horizontal with a rack that has enough space inside for 97"-long sheets of MDF.

To avoid having to lift full sheets over the center containment stretcher (B), the holder uses a hinged "swing-out" design, improving accessibility to the rack.

The trough at the bottom of the rack contains the materials in a defined but generous space. The rear stretcher (B) at the top allows you to firmly mount the rack to wall studs. For greater versatility add two short sections of heavy-duty cardboard carpet tubing to the end (seen on the left side of the photo) to contain dowels and other thin-strip material.

Project design: **Kevin Boyle, Senior Design Editor, WOOD® Magazine**

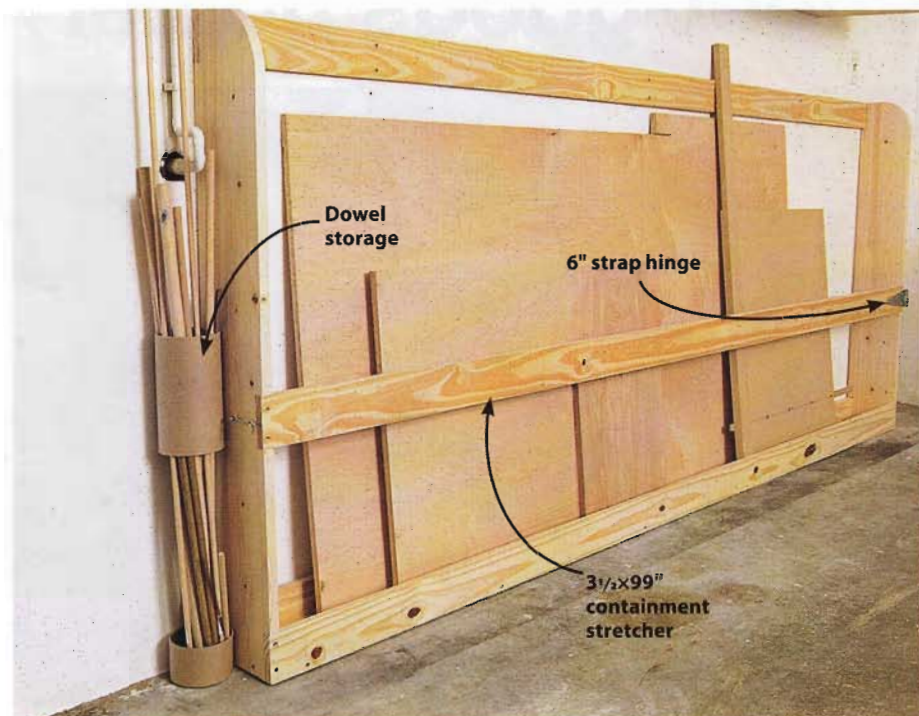

The center containment stretcher (B) of the sheet-goods rack is held in place by a 6" strap hinge screwed to the rack's side, and a "hook and eye" at the other end.

Materials List

Sheet goods rack	FINISHED SIZE			Matl.	Qty.
	T	W	L		
A sides	3/4"	7 1/4"	48"	P	2
B stretchers	3/4"	3 1/2"	99"	P	4
C bottom	3/4"	5 3/4"	97 1/2"	P	1

Materials key: P-pine.

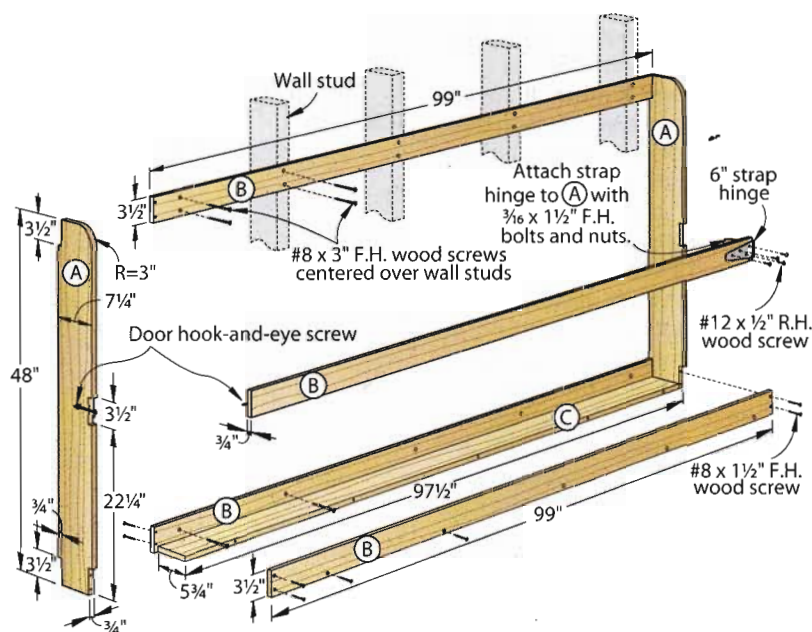

Multilayered **lumber rack** and **sheet-goods holder**

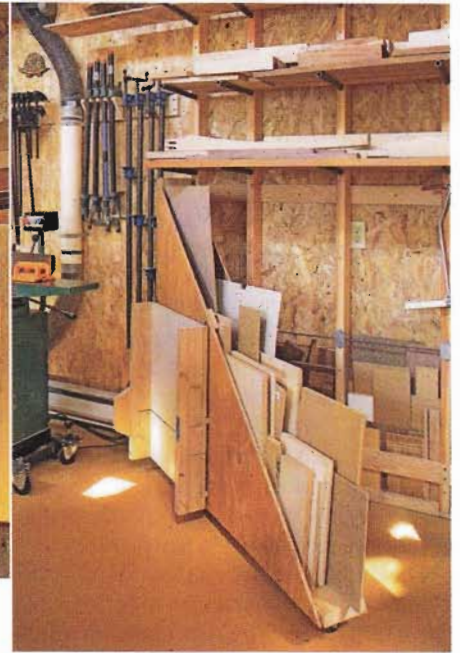

Pack lots of wood in a minimum of space.

This wood-storage system keeps sheet goods and boards close at hand but occupies minimal space. The upright component stores long lumber. It measures 8' high x 6' wide. Attach 2x4s to the wall and drill $\frac{3}{4}$ " holes 3" deep angled upward about 3° into the 2x4s. Then insert 16"-long pieces of $\frac{3}{4}$ " black pipe. Fasten a 1x4 horizontally along the rack face toward the bottom, creating a small cavity between the vertical members where you can store flat stock, dowels, and scraps of fine woods.

The second component is a swinging sheet-goods holder. Make a frame of one vertical and one horizontal 2x6, faced on each side with a 4x4' sheet of plywood cut on the diagonal. The vertical frame piece attaches to the 2x4 on the wall with hinges. A 3" swivel caster attached near the end of the horizontal frame piece allows the unit to swing out easily, providing ready access to materials stored behind.

Project design: **Dale Heisinger, Orcas Island, Wash.**

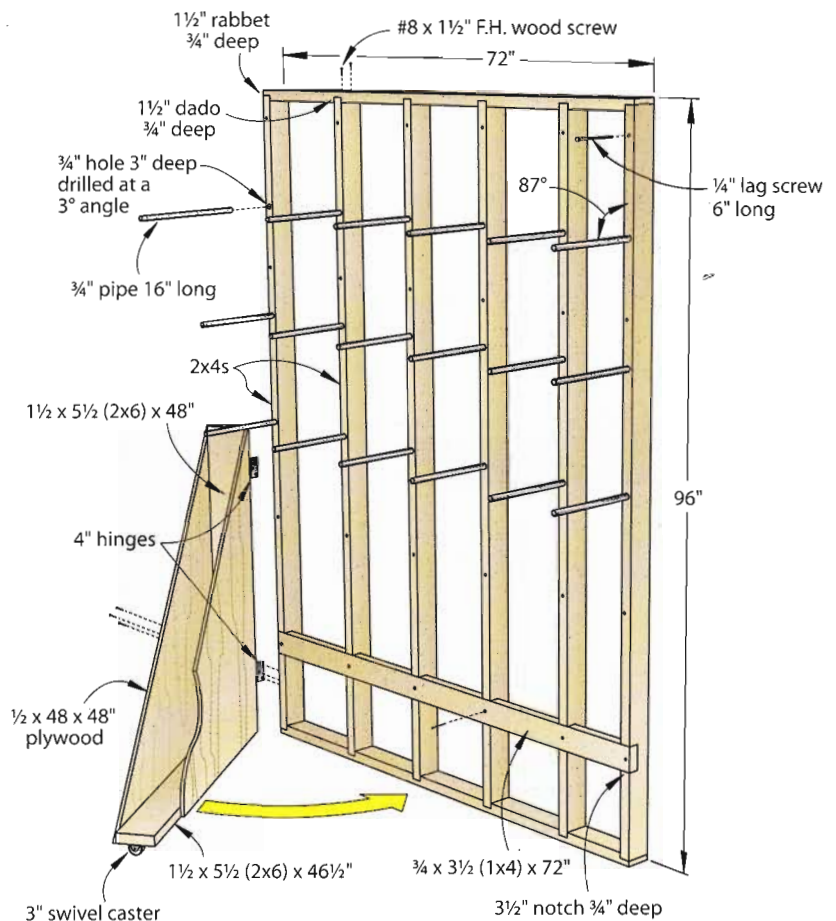

Best-Ever Plans for Your Home

View **1,000+** plans at woodmagazine.com/plans

from the editors of **WOOD** magazine



Entry-Area Bench & Shelf
Plan DP-00509 \$5.95



Home/Shop Storage Cart
Plan DP-00561a \$6.95



Mission Bookcase
Plan DP-00563 \$8.95



End-Grain Cutting Board
Plan DP-00521 \$2.95



Gift-Perfect Wine Box
Plan DP-00529 \$3.95



All-in-order Storage Bins
Plan DP-00558a \$5.95



Young Artist's Easel
DP-00478 \$4.95



Splined Ornamental Box
Plan DP-00161 \$3.95



Heirloom Hope Chest
Plan DP-00190 \$7.95



Beveled Beauty Jewelry Box
Plan DP-00028 \$5.95



Compact Entertainment Center
Plan DP-00474 \$9.95



A Gem of a Jewelry Box
DP-00476 \$5.95



Country-fresh Bed
Plan DP-00081 \$8.95



Country-fresh Dresser
Plan DP-00008 \$8.95



Five-Drawer Chest
Plan DP-00010 \$8.95



Eight-Drawer Dresser
Plan DP-00172 \$9.95



Armoire/TV Entertainment Center
Plan DP-00171 \$9.95



Stackable Bins
Plan DP-00547a \$3.25



Mission Bed
Plan DP-00424 \$9.95



Mission Dresser
Plan DP-00440 \$9.95



Mission Blanket Chest
Plan DP-00446 \$8.95



Mission Nightstand
Plan DP-00433 \$7.95



Cedar-lined Blanket Chest
Plan DP-00534 \$7.95



Heirloom Corner Cabinet
Plan DP-00527 \$9.95



3-in-1 Bed for All Ages
Plan DP-00524 \$9.95



Kid's Oak Bunk Beds
Plans DP-00216 \$5.95



Barristers Bookcase
Plans DP-00181 \$5.95



Quilt Ladder
Plans DP-00596a \$3.95



Morris Chair
Plan DP-00093 \$10.95



Contractor Grade Mobile Crane
DP-00594a \$3.50

Download any of these woodworking plans for the prices listed, or view a larger image, at woodmagazine.com/plans
To have paper plans mailed directly to you (add \$3 per plan plus S+H), call **toll-free 1-888-636-4478**.
Please have your credit card available.

Easy-access stock rack

Compactness and easy access go together to make a space-saving storage winner.

If you do most of your woodworking in a space-challenged shop, material storage is probably a continual problem, especially for long boards. The storage system shown here offers equal access to all stored boards (meaning the one you want will never be pinned on the bottom of a stack). Plus, the racks function like stickers by allowing air to circulate freely around the boards so they acclimate more quickly to your shop's environment.

To make a set of racks, cut 8"-wide parts from $\frac{3}{4}$ " plywood. To store $\frac{3}{4}$ "-thick stock, drill a series of 1" holes, with centers 2" apart. For thicker boards, reserve some space for $1\frac{1}{2}$ "-diameter holes, centered 3" apart. (As shown, a 48"-long rack will hold sixteen $4/4$ boards and three $6/4$ boards.)

Lay out the slots of the rack by extending two 20° lines out from each hole with a sliding bevel [Drawing 1] and then cut out the slots with a jigsaw.

For wall mounting, add a $1\frac{1}{2}$ " cleat alongside each rack [Drawing 1a], or simply suspend the racks by screwing them to the side of ceiling/floor joists.

Project design: **Larry Courtois, Imperial, Mo.**

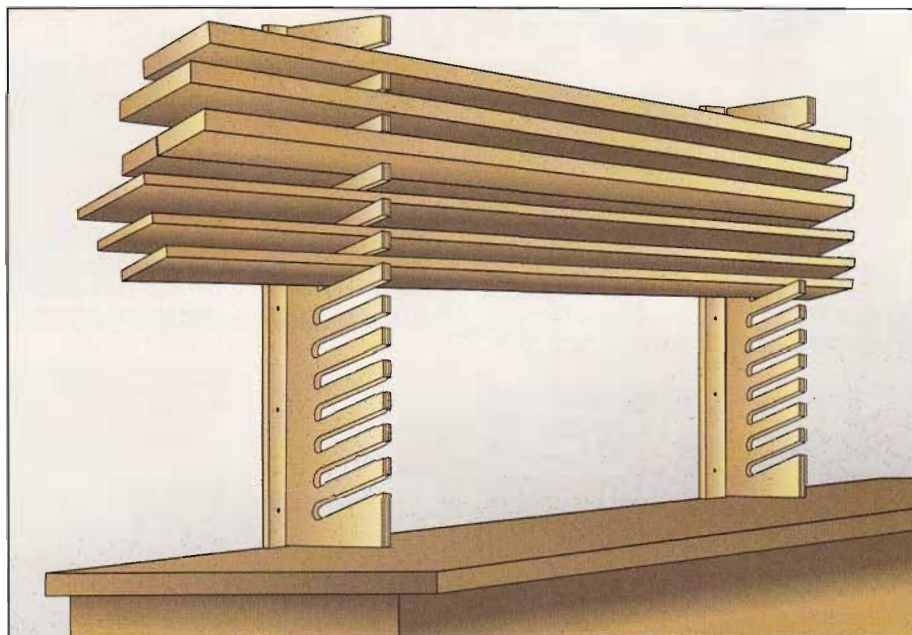

1 RACK SLOT LAYOUT

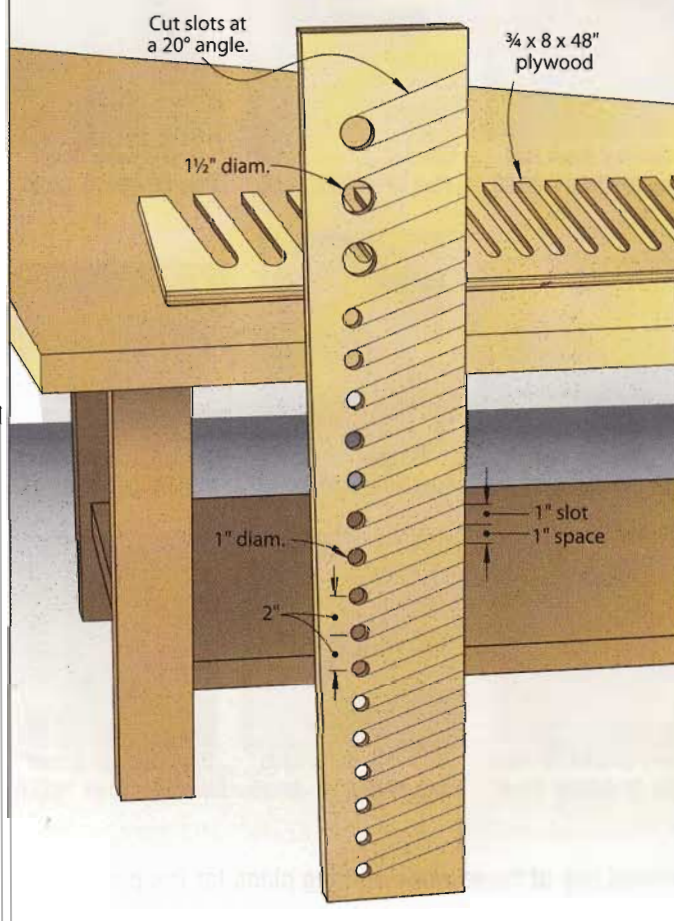

1a WALL MOUNTING DETAIL

Top view

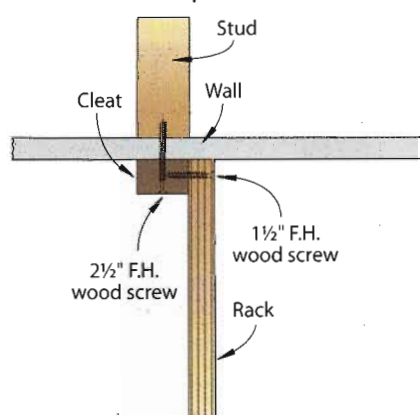

Combination lumber/clamp rack

When lumber and clamps share a single space, both can be ready for woodworking at a moment's notice.

Your lumber is long and straight, and so are your pipe clamps. You need a place to store both, so how about combining two goals with a single rack?

The shelf supports for this lumber rack also serve as clamp holders, making them accessible and keeping the shop neat at the same time. This is an especially good shop solution if you have a smaller shop that's short on wall space.

The vertical hardwood supports provide convenient locations for clamp storage; 2 1/8" holes drilled through the first pair of supports in each row hold bar clamps. Short stock occupies the space between the horizontal supports.



Project design: **Fred Collins, South Duxbury, Vt.**

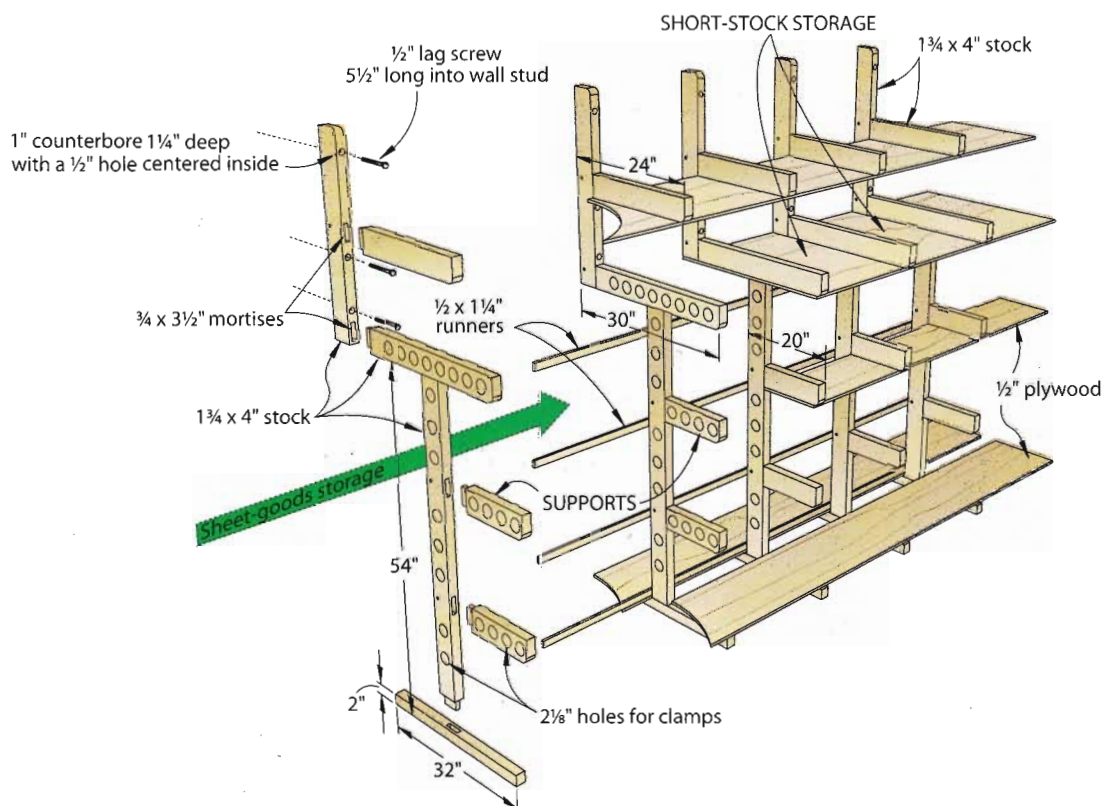

Hang-anywhere **clamp racks**

Here, there, anywhere:
Made with hanger holes,
these clamp racks can be
moved at will.

For woodworkers who change their shop layouts from time to time, these clamp racks are just what the doctor ordered. Hanger holes allow them to be mounted on dowels, hooks, screws, nails, or whatever you have, meaning that their locations are never permanent.

Project design: **Kevin Boyle, Senior Design Editor,**
WOOD® Magazine

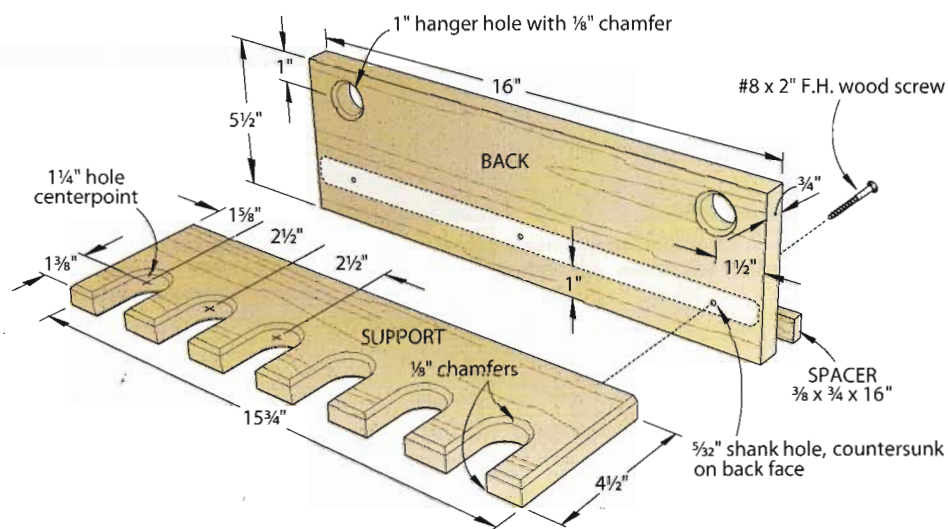
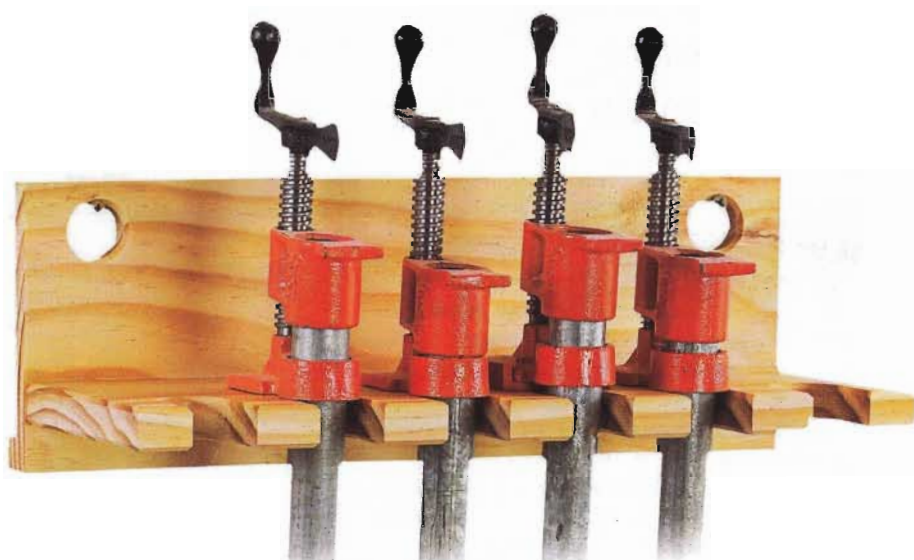

Pipe-clamp rack

Pipe clamps are often found standing in the corner of the shop or on the floor in a pile. The rack shown *above*, made from $\frac{3}{4}$ " stock, has six notches for clamps. Extend the lengths of the shelf and back in $2\frac{1}{2}$ " increments to hold even more clamps. The spacer adhered on the back side of the unit angles the shelf slightly so the clamps don't slide to the front of the support and fall off.

To make one, mark the centerpoints of the notches where dimensioned on the drawing. Use a flat-bottomed or spade bit to bore a $1\frac{1}{4}$ " hole at each marked centerpoint. Rely on a small square to mark the cutlines from the front edge of the support to the outside edge of each hole.

Cut along the lines with a bandsaw or jigsaw to finish forming the notches. You can use the same cutouts for rectangular bar clamps, or simply cut rectangular-

shaped openings. Now, bore the 1" hanger holes. Rout chamfers along the edges indicated for a smooth appearance and to prevent chipping of the edges when the racks are moved around.

Next, clamp the support to the back, countersink mounting holes through the back into the support and then glue and screw the two parts together. Glue the spacer to the back where shown.

C-clamp holder

To organize C-clamps, make one of these holders for each size clamp. First, measure the openings of your clamps and size the width of the protruding shelf $\frac{1}{2}$ " less than that measurement. To construct the holder, cut the back, support, and spacer to size from $\frac{3}{4}$ " stock. Next, mark the center-points and bore the hanger holes through the back. Chamfer the hanger holes plus the edges and one end of the support on both faces. Then, attach the support to the back, where shown on the drawing, using glue and #8x2" flathead wood screws. Next, glue and clamp the spacer in place.

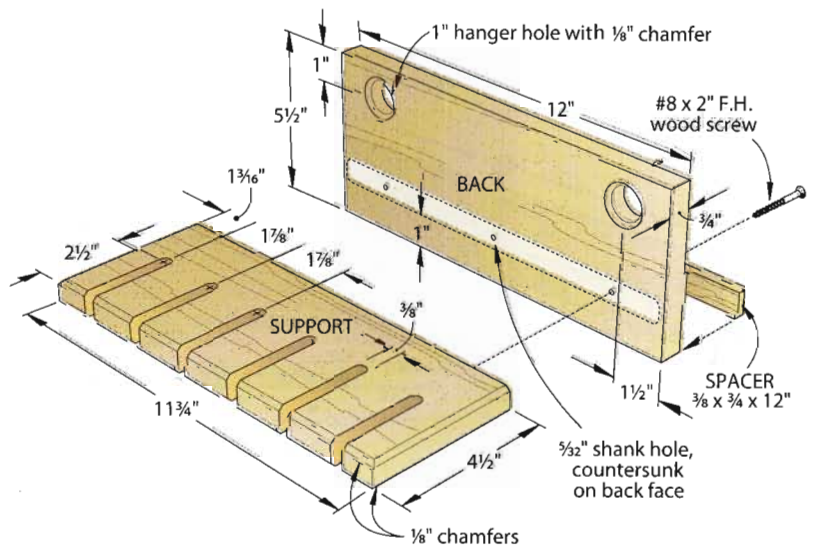
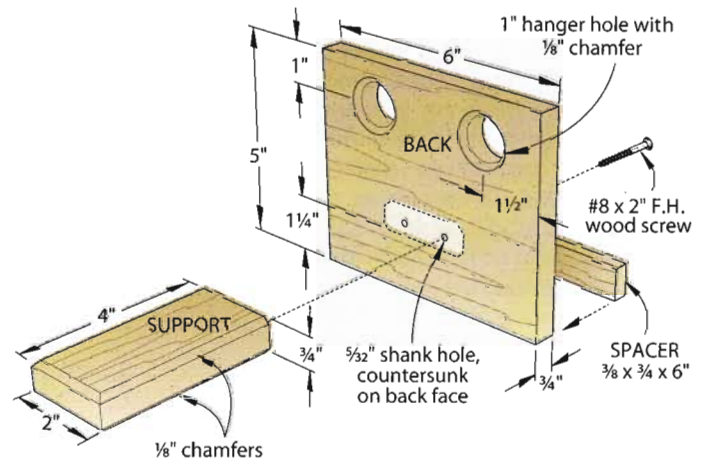
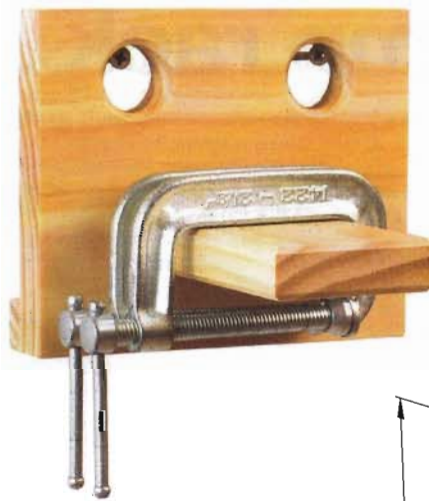

Bar-clamp rack

This small bar-clamp organizer can hang on the wall, but it's also perfectly sized to mount on tool cabinets. Cut the back, support, and spacer to the sizes noted on the drawing from $\frac{3}{4}$ " stock. Mark the center-

points of the hanger holes and the clamp points where indicated. Now, chamfer the edges of the support. Bore the hanger holes and cut the slots to shape. Drill the mounting holes, and glue and screw the pieces together where shown.

Basic bar-clamp rack

Clamp storage doesn't have to be fancy to get the job done.

When you need to get clamps up and out of the way, there's no reason to be fancy about it. Sometimes basic is better. These simple bar-clamp racks are made up in pairs—one on top and one on the bottom—and hold eleven 24" bar clamps perfectly for the space allotted. Of course you can make the holders as long or as short as you need them, depending on how much room you have in their intended mounting spot.

The racks shown are made of $\frac{3}{4}$ " oak, but any hardwood will work just fine. Mount the racks at an appropriate distance apart based on the size of the clamps you plan to store there, and just slide them into place in the slots. Gravity does the rest to hold the clamps in place.

Project design: **Scott Beresford, Pittsburgh, Pa.**

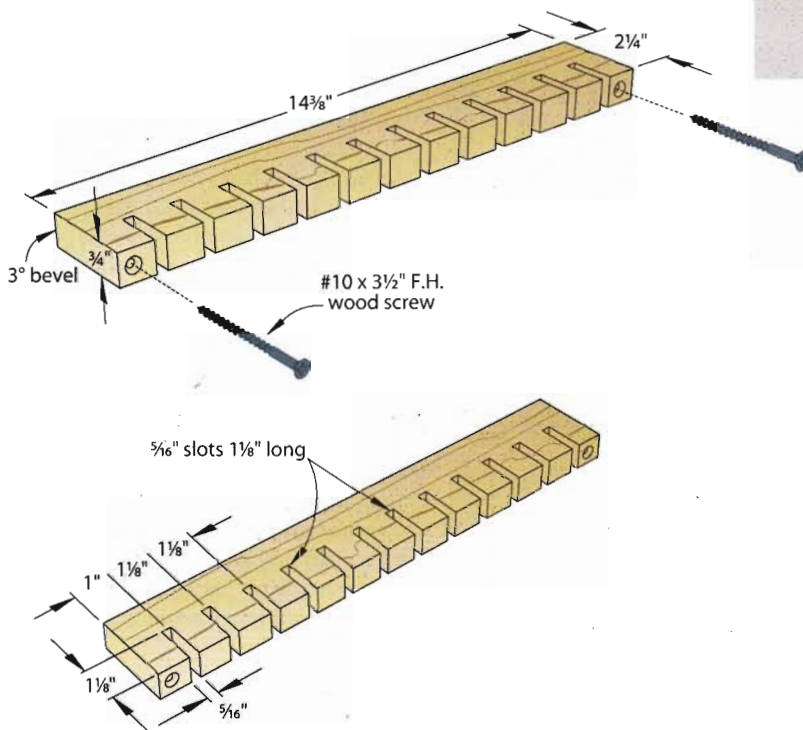

QUICK TIP: CLAMPING PROTECTION

Most better-quality bar clamps come with soft plastic protectors to prevent marring wood when clamping. If you've lost clamp pads or can't find any to fit the clamps you have, here's another way to go. Coat the business end of your clamps with the plastic-dip material marketed to coat tool handles. It dries to a soft, flexible coating that will protect even finished wood. Apply it by dipping or brushing, taking care to keep it out of movable joints or threads.

—Raymond Babcock, San Angelo, Texas

Frame-style clamp hanger

With its open-frame design, this rack accommodates a variety of clamps in a compact space.

It may not be apparent at first glance, but this simply constructed wall-mounted unit can store an assortment of 90 clamps. Made from inexpensive pine, it offers shelves and dowels for organizing anything from pipe clamps to one-hand bar clamps to spring clamps. To build it, just follow the drawing dimensions *below* when cutting the pieces; then, assemble the unit with glue and screws. Or, if you wish, alter the design to better suit your own clamp collection. Secure it to wall studs with screws or hang it with a cleat system.

Project design: **Rod Cox, St. Paul, Iowa**

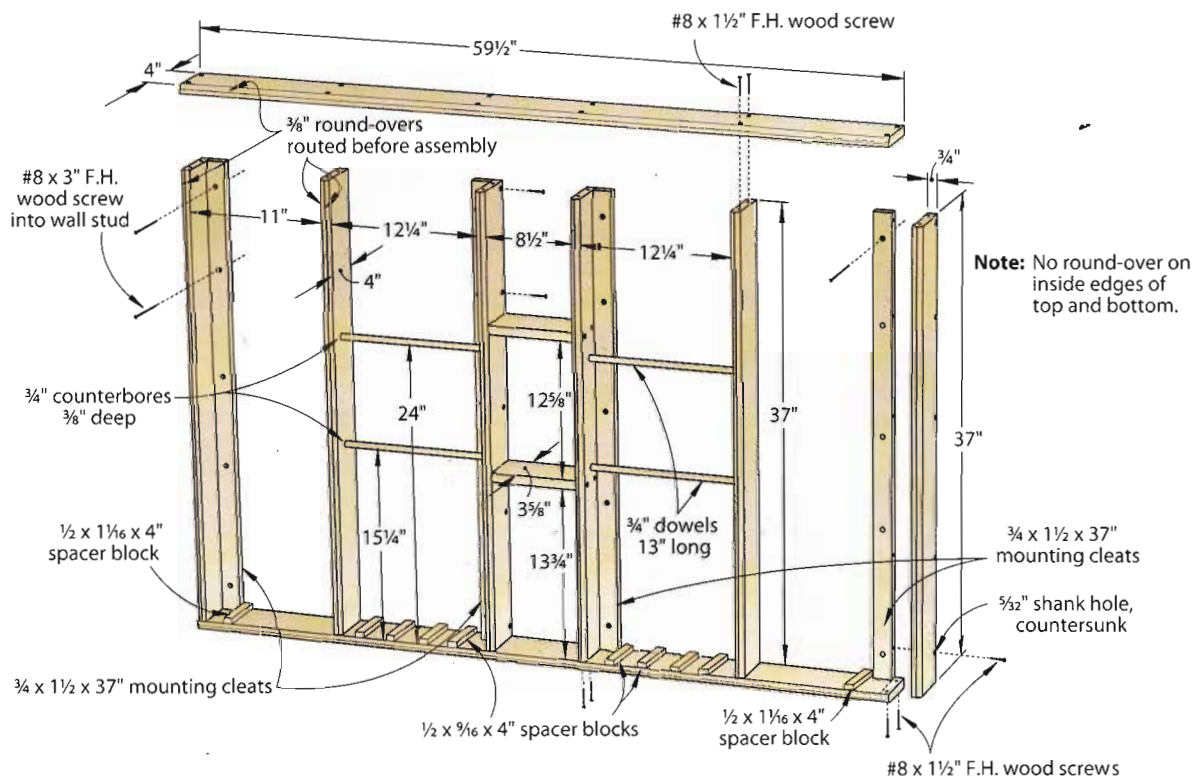

Angle-iron clamp rack

Own a welder? Or know someone who does? Then try this.

This mobile clamp rack is made almost entirely of 1½" angle iron, except for the upper clamp guide, which is 1" angle iron (to allow clearance space for the clamps' bars). Clamps are secured by 1¾" chain links cut in half and then welded to the angle irons on 1¾" centers to serve as clamp guides.

Project design: **Mike Connolly, Concord, N.H.**

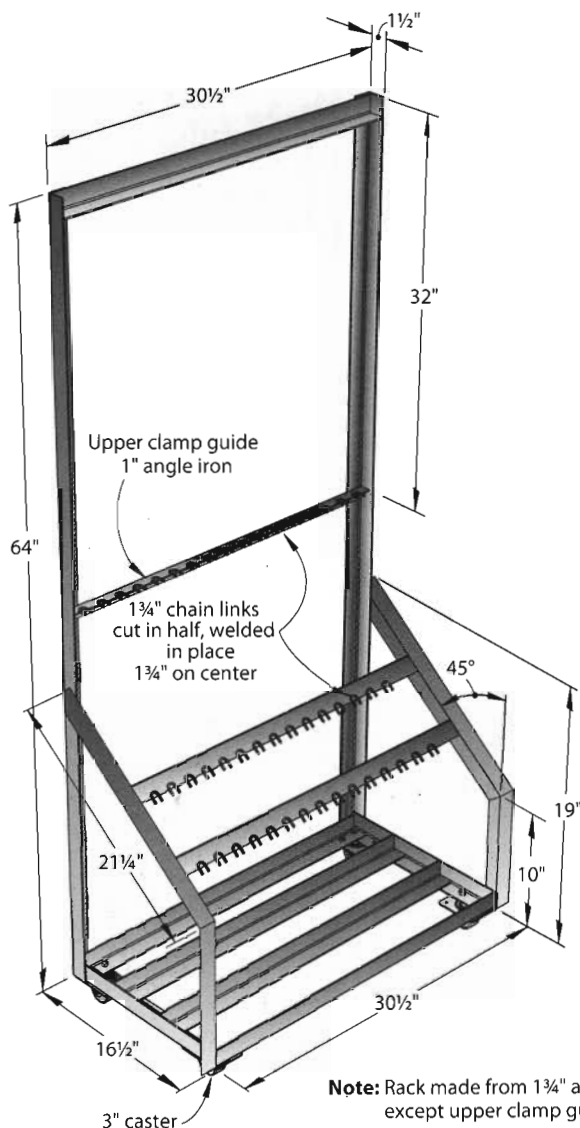

QUICK TIP: PREVENTING CLAMP

I always worry about marring the wood with my clamps during dry assembly or glue-up of a project. Rather than buying the costly custom pads available to fit my clamps, I purchased some hard felt chair glides. They have self-adhesive backing and come in various sizes and shapes, so it's easy to find some just the right size for your clamps.

—*Sonny Rains, Carbondale, Colo.*

Double-duty TV shelf/clamp rack

“What’s on TV tonight?” In this shop, it’s an organized set of clamps.

Every now and then the best-laid plans of woodworkers take a backseat to pure luck. When Randy Zimmerman built this corner shelf for his shop, his intention was to use it just to hold a portable TV. Later, however, he discovered that he’d allowed enough of an edge that his clamps could simply grip the front rail and support cleats. Once the TV-shelf-turned-storage-center proved its merit, he added a second set of cleats into the corner below the TV shelf for even more clamp storage.

Project design: **Randy Zimmerman**,
Indianola, Iowa

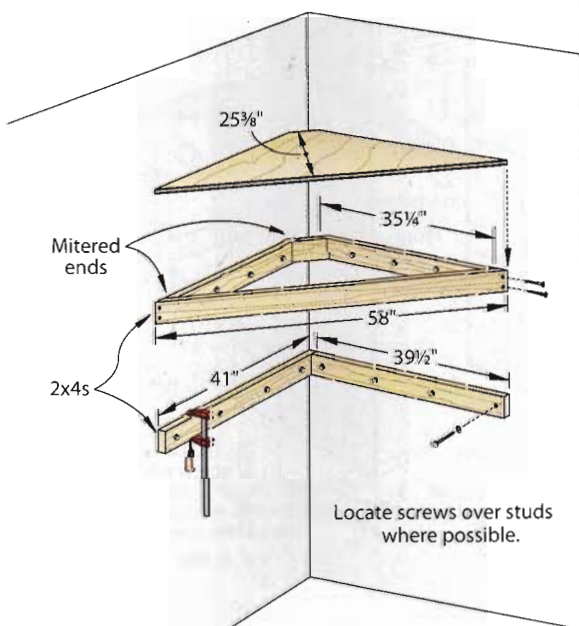

QUICK TIP: PREVENT CLAMP MARRING

To keep clamps from marring project surfaces, use the plastic caps found on milk jugs as pads. Hold a pair of the caps, which normally aren't recycled with used jugs, in place with a few dabs of hotmelt glue.

—Jerry Pasley, Raleigh, N.C.

Drop-down drying rack

A great space-saving solution for small shops.

Lots of finishing to do but limited on space? Try this multilevel drying rack. The removable PVC pipes allow you to create "shelves" for supporting cabinet doors and other workpieces while they dry. To build the rack, cut the front and back from $\frac{1}{4}$ " plywood. Mark the hole centerpoints where dimensioned on one of the two pieces. Stick the pieces together with double-faced tape, with the edges and ends flush. Use a $1\frac{3}{4}$ " Forstner bit or circle cutter to bore holes through both pieces of stock at the same time. Back the stock to prevent chip-out.

Next, cut the two sides and three dividers to size from $\frac{3}{4}$ " stock. Radius the top end of each sidepiece and bore a 1" hole to house the hanging dowel. Drill all the mounting holes and assemble the unit in the configuration shown at *right*, checking for square. A screw driven into the top radiused end of each sidepiece secures the 1" dowel in place.

To mount the rack to the ceiling, drill the four mounting holes, and thread pairs of bike hooks and screw eyes into the pilot holes, where shown on the drawing. Add utility chain to the screw eyes. Finally, crosscut numerous pieces of $1\frac{5}{8}$ " PVC pipe to length.

When not needed, simply remove the PVC pipes from the rack. Then, lift the bottom end of the rack to the ceiling, securing the spring snaps to the utility chain, as shown in the inset photo *above*. Store the pipes in a 5-gallon bucket.

Project design: **Tom Carrell, Metropolis, Ill.**

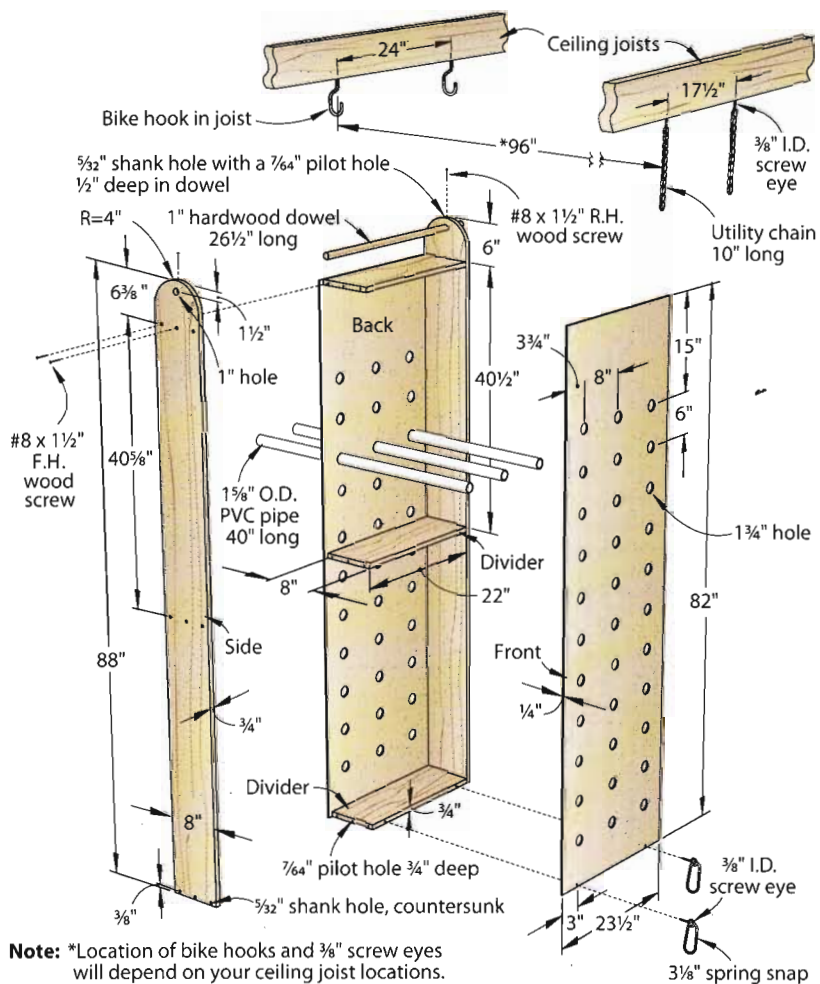

Find tips and ideas for all your finishing needs at: woodmagazine.com/finishing

Contoured **tool holders**

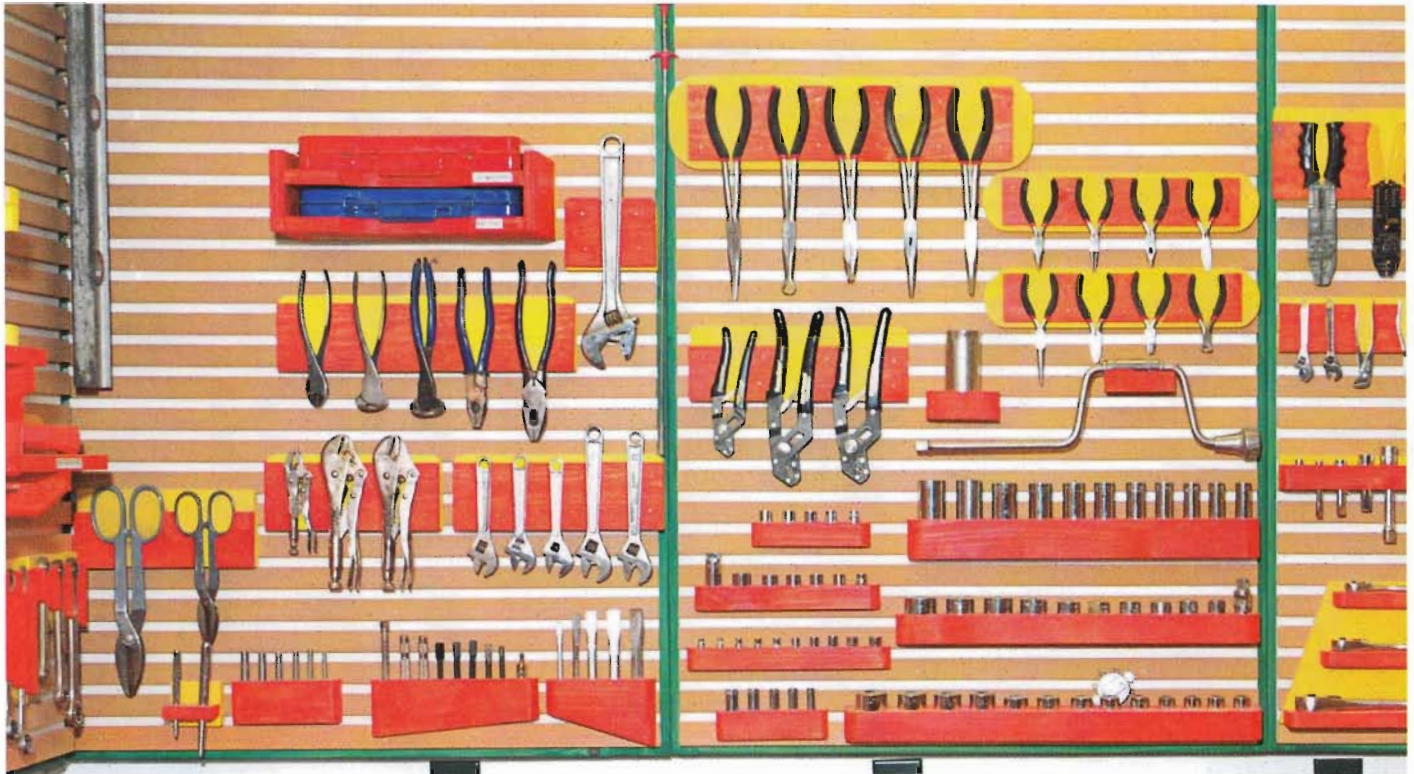

For hand tools or power tools, these custom holders are a perfect fit.

With rabbeted hardwood cleats mounted onto the backs of melamine-coated particleboard, Leland Frerichs created a tool-hanging system that's every bit as good-looking as it is functional. Use the drawings on the next two pages to make a similar system for your shop.

Note: To fashion these hand-tool holders, lay each tool on wood, carefully trace around the perimeter, and cut out a left-hand and right-hand side for each tool. The slightest amount of space keeps them snug.

Project design: **Leland Frerichs, Longview, Wash.**

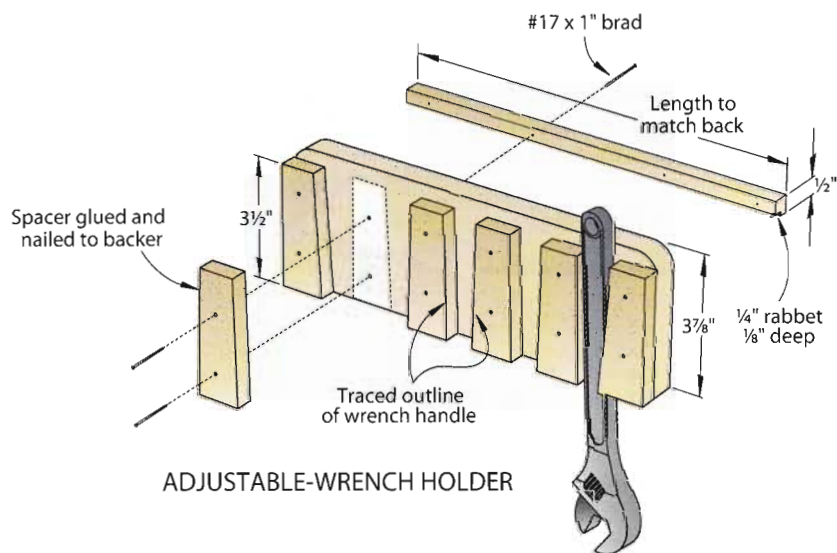

From the simplest hand tools to the most sophisticated shop machinery, read the latest reviews at:

woodmagazine.com/toolreviews



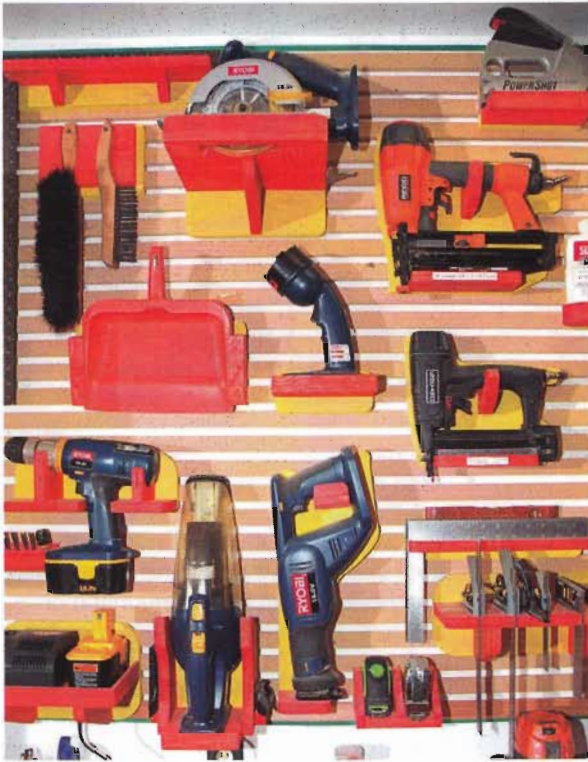

Power-tool and accessory holders

Although they're generally larger than the holders for hand tools, the versions shown at *left* for power tools are fashioned in exactly the same manner. For most hand-tool holders, a single hanging cleat attached to the upper back will do the trick. But for heavier power tools, consider attaching a second set of mounting cleats (like that shown *below*) to the hanging cleat on the lower back to better distribute the weight of the tool.

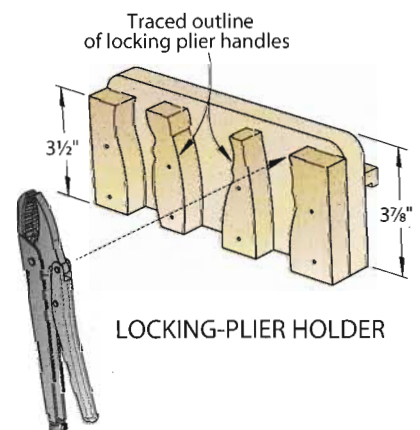
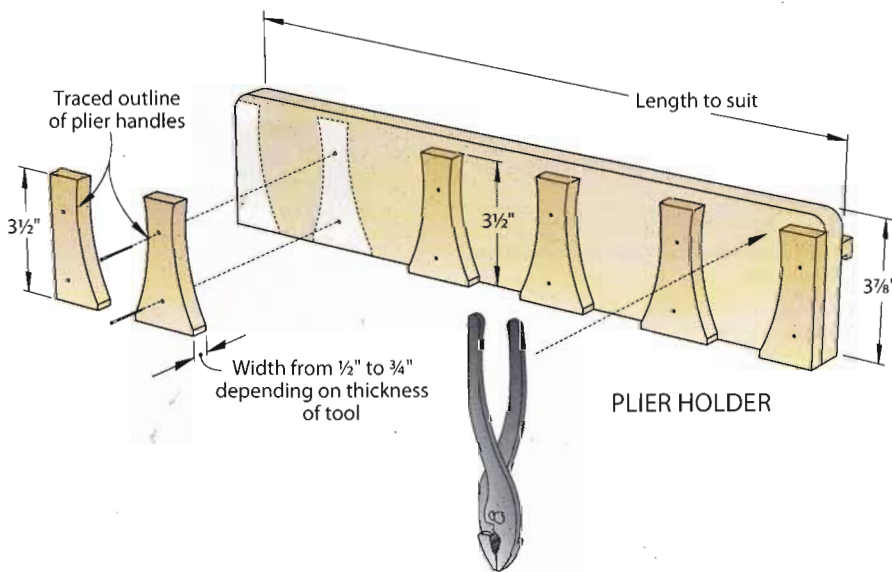
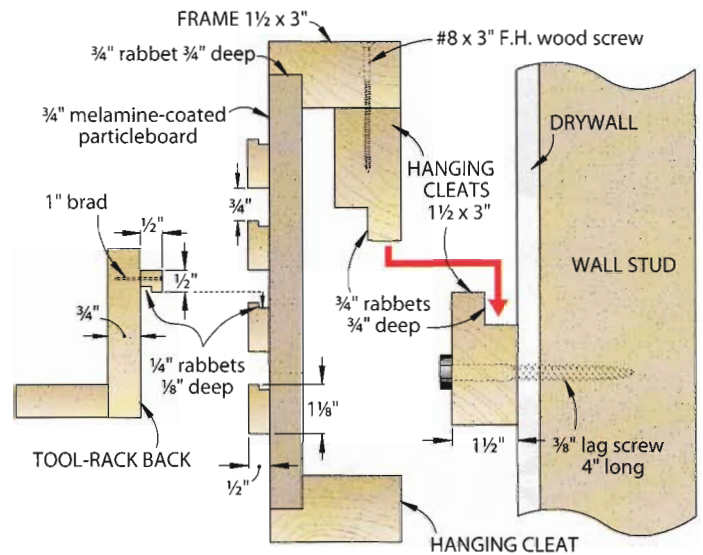

Edge-protecting chisel rack

Keep chisels handy, and their tips shielded

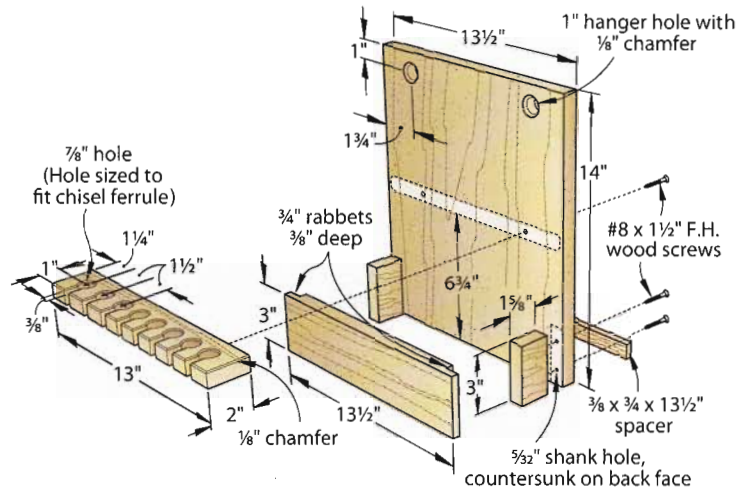

To keep chisels sharp and easy to find, keep them in this basic storage rack. Cut the front, back, sides, shelf, and spacer to the sizes shown on the drawing. Locate and bore the hanger holes in the shelf and the chisel holes in the shelf. (You may have to adjust the hole size in the shelf to fit your chisels.) Now, saw

out the waste between the front edge of the shelf and the chisel holes. Chamfer the shelf edges and rabbet the front where shown. To finish, drill the mounting holes, and glue and screw the rack together.

Project design: **Kevin Boyle, Senior Design Editor, WOOD® Magazine**

Pencil box with sharpener support

Some shop accessories should go together, and this project sees to it.

To build this handy holder, cut the front, back, sides, bottom, and spacer to the sizes shown on the drawing from 3/4" stock. Drill the mounting holes and rabbet the front as shown. Glue and screw the parts together. Complete the project by attaching a pencil sharpener to the bottom.

Project design: **Kevin Boyle, Senior Design Editor, WOOD® Magazine**

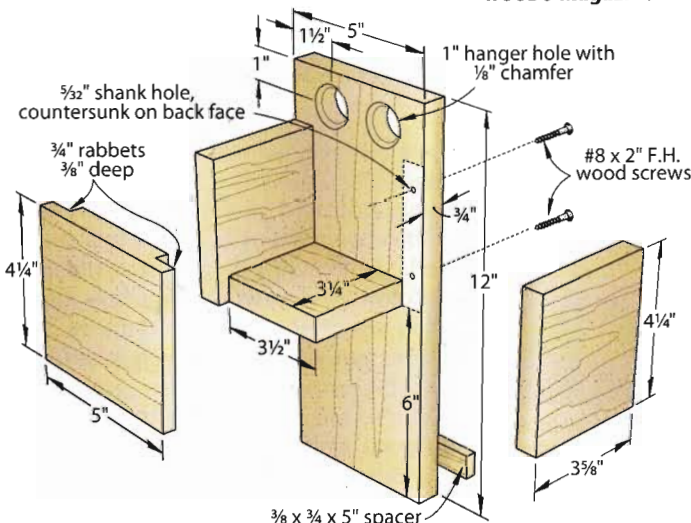

Built-to-fit sandpaper holder

This organizer stores abrasives close at hand and keeps them tightly rolled till ready for use.

Because they're designed to mount on a round drum, abrasive strips are best stored rolled up until needed. This rack, sized for an exact fit in the base of the drum sander shown at right, has numerous small compartments that keep the sandpaper strips from uncoiling.

To make one of your own, carefully measure the stand or base of your sander and adjust the drawing, below, to match your machine's dimensions.

Project design: **Tom Whalley, Urbandale, Iowa**

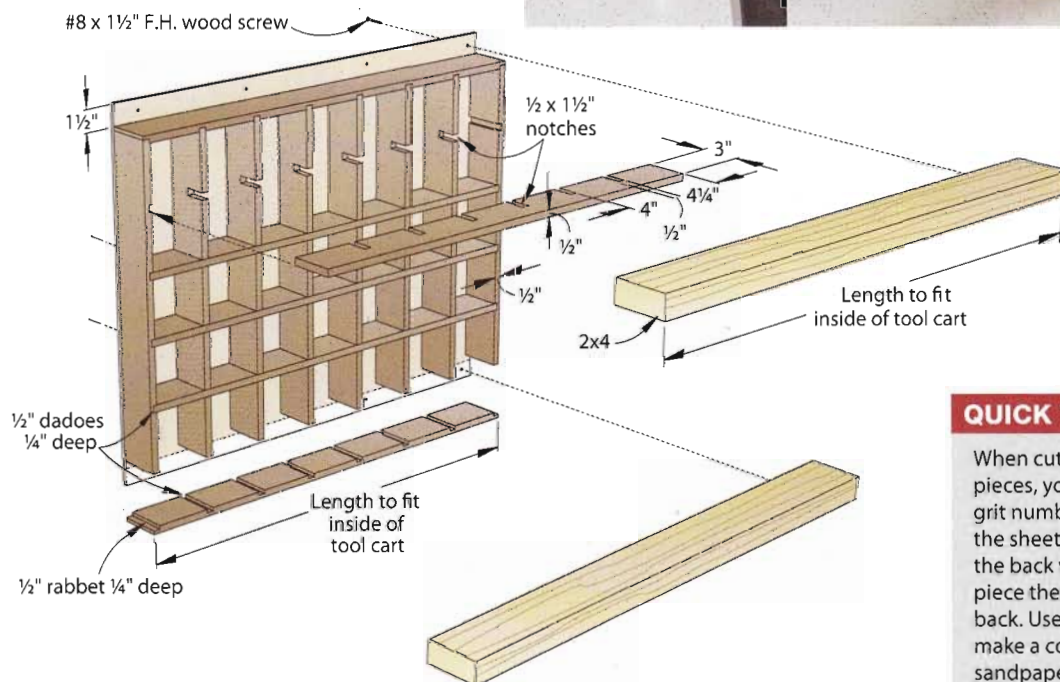

QUICK TIP: SANDING GRIT ID

When cutting sandpaper into smaller pieces, you can bet several won't have the grit number on the back. Before you cut the sheet, scribble a crosshatch pattern on the back with a colored marker. Each cut piece then will have colored lines on the back. Use a different color for each grit, and make a color-key chart to keep with the sandpaper. Then, you can readily identify the grit.

—Daniel Angert, Orlando, Fla.

Hang-and-go lathe-tool holder

When you create a mountable chisel caddy, who says it has to stay in one place?

This quick-to-make project slides between the rails in the lathe bed (known as the ways) and cradles turning tools within arm's reach. When not in use, it hangs on the wall, out of the way. Feel free to customize it for the type and number of turning tools you own.

To size your tool holder, first measure the overall length of your turning tools to determine the length for the backboard (A). The one here is 21", just a bit shorter than most of the tools. Now, measure from the butt end of the handles to the ferrules (the rings on the handles near the blades). This determines the distance between the upper rest (B) and base (D), as shown.

Next, measure the diameter of each tool's ferrule and of each handle 2" from the butt end. Cut two 2x10³/₄" plywood strips to make the upper rest (B) and lower rest (C), and mark lines 1¹/₄" from one



edge. Lay out hole centerpoints along those lines, where dimensioned on part B, below. Drill holes to match the ferrules in one strip and to match the handles in the other. Rip the rests (B, C) to width and attach them to the backboard. Then, add the base (D). A screw in each edge of the backboard retains a 10" miniature bungee cord that secures the tools.

The cleat and retainer (E, F) are sized to fit most lathes, but check the distance between the ways on your lathe. The cleat needs about 1/4" clearance to slide easily. Make the wall-mount parts (H, I) and secure this assembly to a wall stud.

Project design: **Jeff Mertz, Design Editor, WOOD® Magazine**

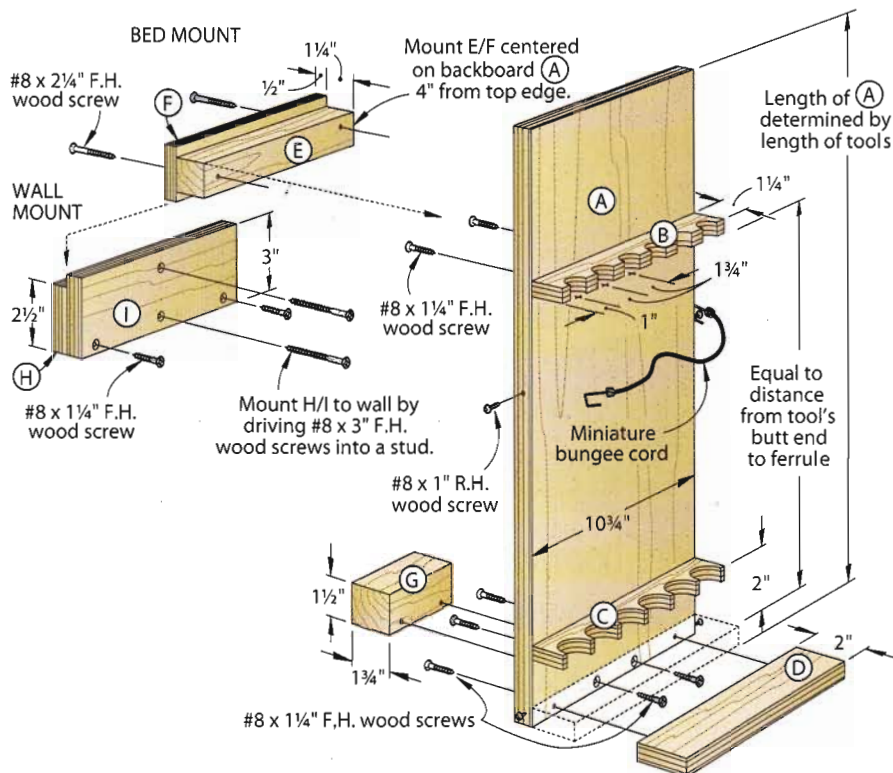

Materials List

Part	FINISHED SIZE			Matl.	Qty.
	T	W	L		
A backboard	3/4"	10 3/4"	21"***	BP	1
B* upper rest	3/4"	1 1/4"	10 3/4"	BP	1
C lower rest	3/4"	1 1/4"	10 3/4"	BP	1
D base	3/4"	2"	10 3/4"	BP	1
E cleat	1 1/2"	1 1/4"	9 3/4"	P	1
F retainer	1/2"	2"	9 3/4"	BP	1
G base block	1 1/2"	1 3/4"	4"	P	1
H hanger strip	3/4"	2 1/2"	9 3/4"	BP	1
I hanger cap	3/4"	3"	9 3/4"	BP	1

*Parts initially cut oversize. See the instructions.

**Actual length determined by length of tools

Materials key: BP—birch plywood, P—pine.

Supplies: #8x1 1/4" flathead wood screws (10), #8x2 1/4" flathead wood screws (2), #8x3" flathead wood screws (2), #8x1" roundhead wood screws (4), 10" bungee cord.

Swing-arm chisel support

Keep lathe tools close with a handy swing-out holder.

Build a holder as shown or customize it to fit your tool needs. Begin by measuring the distance between the lathe's ways to create the sliding support shown in the End-View Detail [Drawing 1a]. Make the sliding support about $\frac{1}{8}$ " narrower than the opening between the ways, and the top edge of the support $\frac{1}{8}$ " lower than the top edge of the ways.

The pivoting arm shown in the Exploded View [Drawing 1] measures $31\frac{1}{2}$ ", but you can shorten for fewer tools lathe-side. To create the holes for the tools, measure the diameter of your lathe-tool ferrules and use Forstner or spade bits to drill holes $\frac{1}{8}$ " larger than that dimension. For skewers, where the blade can be wider than the ferrule, measure the widest diameter of the tool handle and drill the hole $\frac{1}{4}$ " smaller.

Once assembled and attached to the lathe, the holder can stay put on your lathe stocked with turning tools. Or, remove the tools and slide off the holder, hanging it from a wall hook for later use.

Project design: **Bill Adler, West Des Moines, Iowa**

Find more shop organizer plans at: woodmagazine.com/freeplans



Tighten the knob to secure the sliding support and arm to the metal ways.

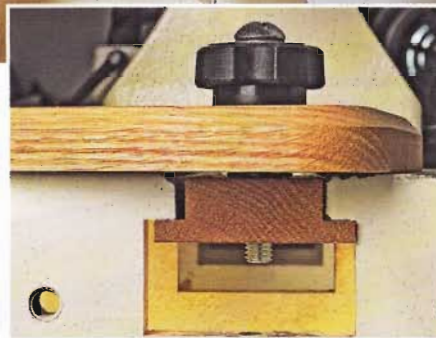

1a END-VIEW DETAIL

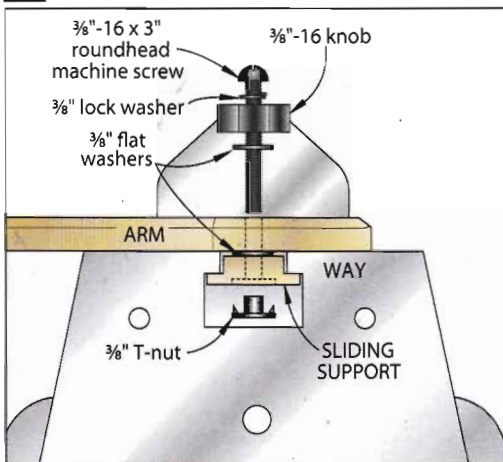

1 EXPLODED VIEW

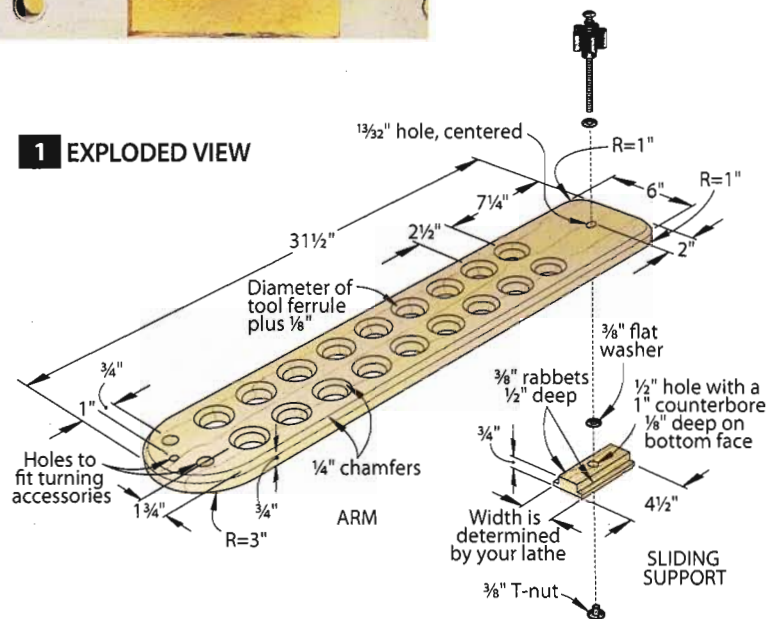

Rack for **chisels** and **measuring tools**

This adaptable home for frequently used tools creates a handsome display.

The magnetic bar across the top of this rack secures chisels and gauges vertically, while an added base beneath heavier chisels and turning tools supports the handles. The arrangement keeps all the sharp cutting edges in the same part of the rack. Made from standard dimensional lumber with a 1/2"-thick plywood back, adjust the overall size of the unit as well as the length and placement of the individual holders to suit your needs.

Project design: **Robert Burgoyne, Peyton, Colo.**

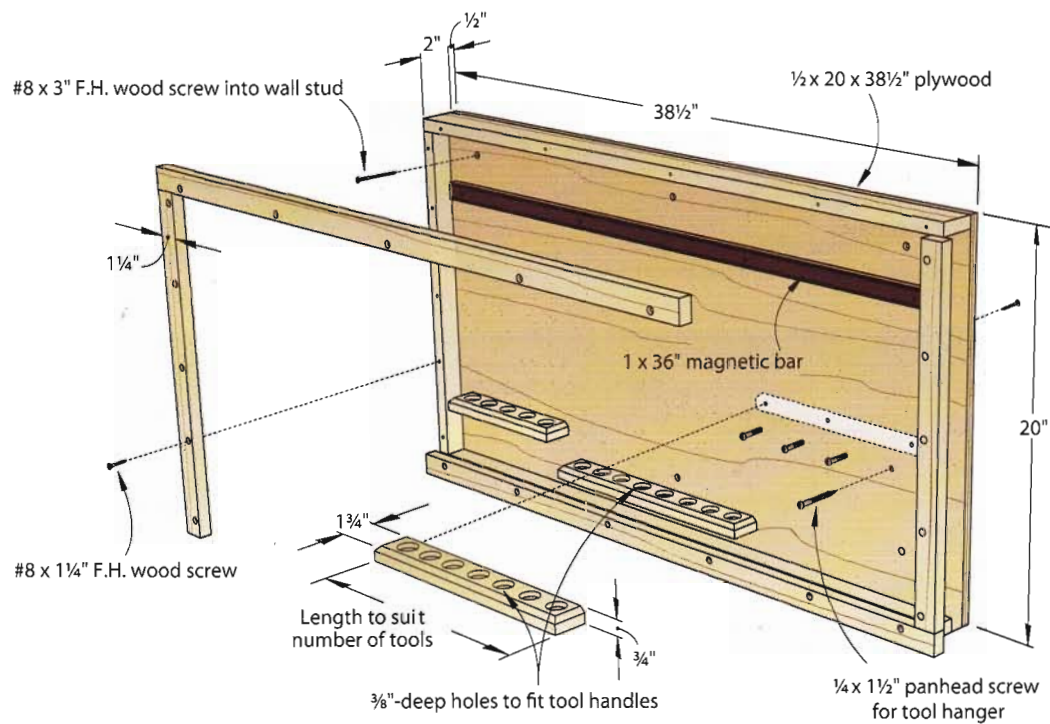

Hanging Forstner-bit holder

A wall-mounted rack keeps all your bits organized.

A 2x4 ripped into 1½" strips forms the basis for this Forstner bit holder. Each 1½"-wide strip has a shallow dust-relief groove on the back side that allows any chips or debris that may land in a nonoccupied hole to fall out the bottom. A 1" spacer separates the drilled strips, and a spacer block attached to the back side of the assembly angles the holder slightly in relation to the wall, keeping the bits in place. While the holder shown here is made for use on a cleat-based hanging system, it's easily adaptable for direct wall mounting.

Project design: **Phil Bumbalough, Metamora, Ill.**

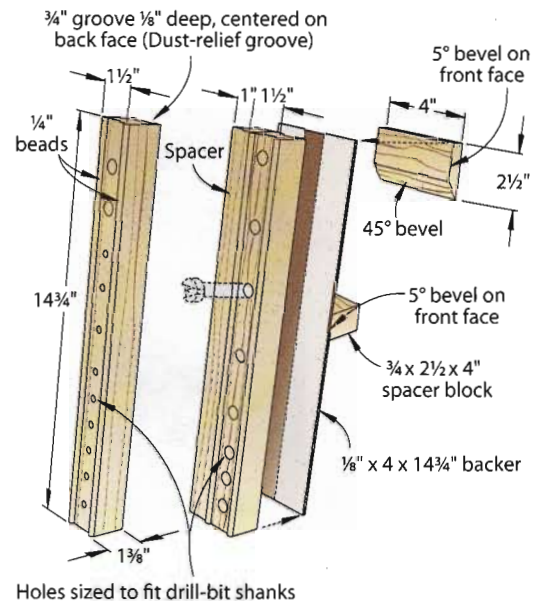

Cleat-mounted radio shelf



Music and news are always at arm's reach.

The handy entertainment center shown here is a mix of ¾"-thick medium-density fiberboard, plywood, and solid-wood trim, but you can use any available stock. Adjust placement of the cord access hole to match your radio. With additional wall cleats, you can have music anywhere in the shop.

Project design: **Chris Finnerty, Ashburn, Va.**

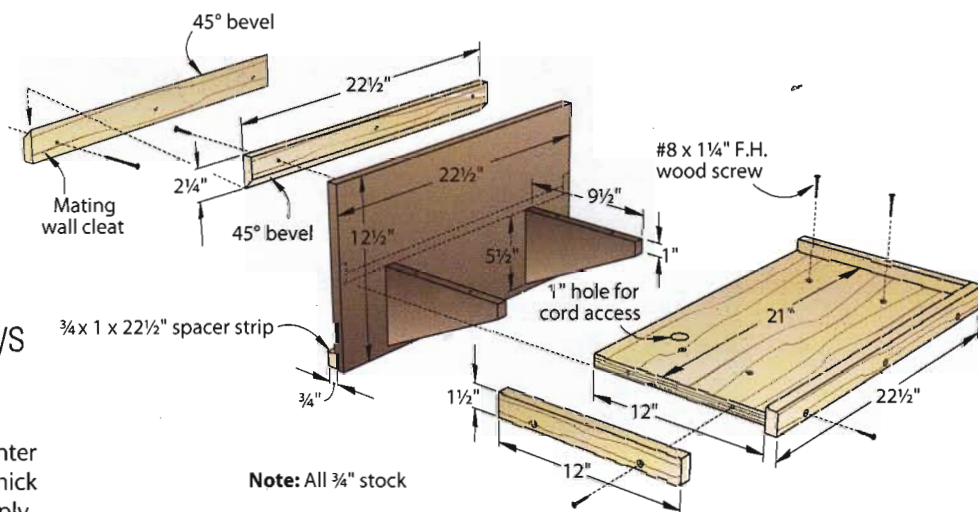

Hardware and Accessory Storage

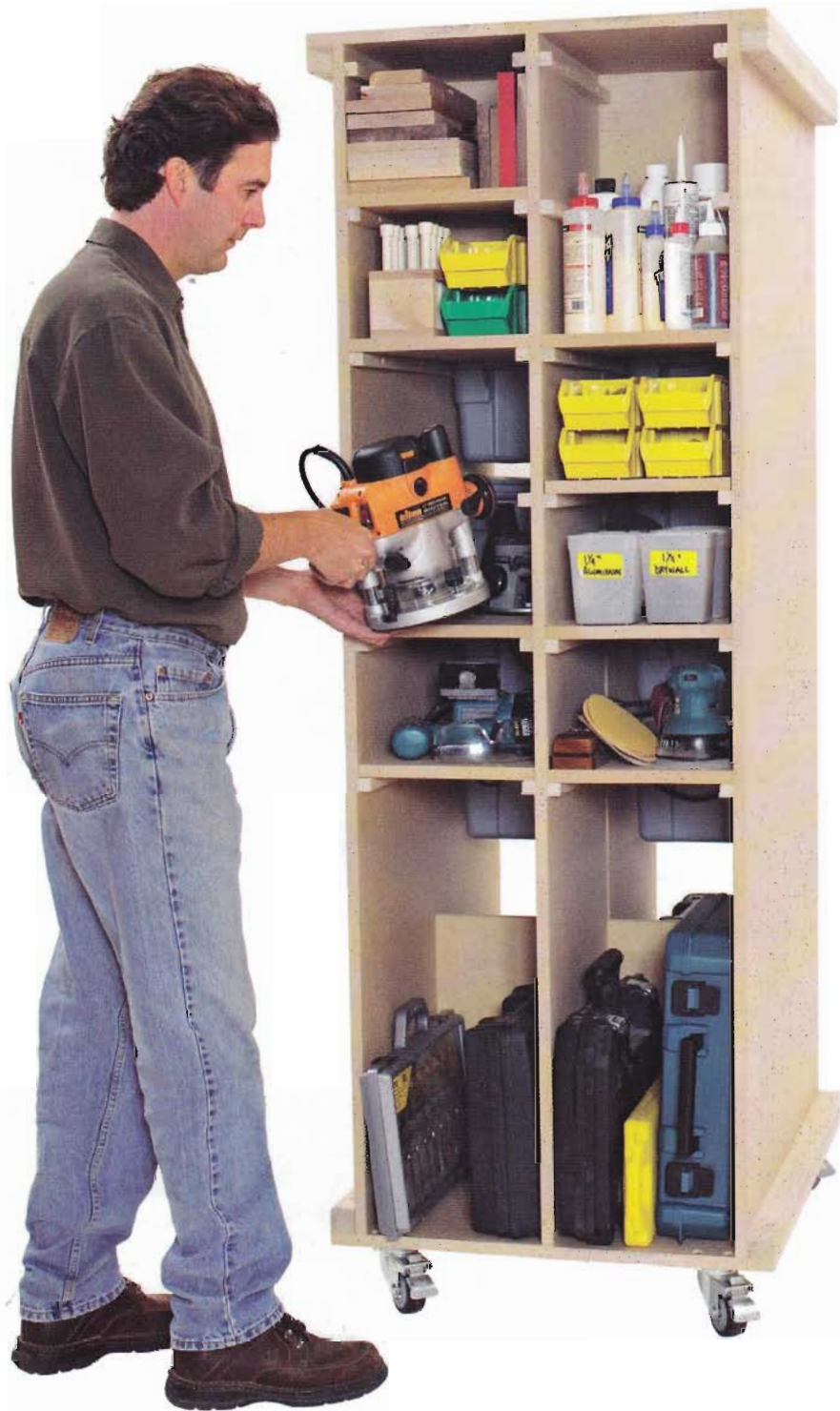

KEEP IT ALL TOGETHER Small things, such as hardware and accessories, have just as important a role in the shop as machinery and lumber. Unfortunately, those little things can also lead to shop clutter. Here are 22 projects to keep it all under control.

Rolling storage cart

This shop helper brings order to chaos.

The design of this unit revolves around plastic storage tubs like those sold in home centers and large discount stores. Our version houses Rubbermaid Roughneck Storage Tote 3-gallon/11.3-liter containers, but just about any kind will do. Just be sure to adjust the project dimensions to fit the tubs you select.

The entire project, minus the optional shelves and cleats, is built from two sheets of medium-density fiberboard (MDF), but $\frac{3}{4}$ " birch plywood would also work well. Start by cutting the parts to size as noted in **Drawing 1**. See **Drawing 2** for optimal sheet-goods usage. Rout a $\frac{1}{8}$ " round-over along

the one exposed edge of each $1\frac{1}{2} \times 1\frac{1}{2}$ " cleat and along the top edge of each $\frac{3}{4} \times \frac{3}{4}$ " cleat where shown. (The round-over on the interior cleats allows the tubs to slide easier.) Then, drill the countersunk mounting holes through all parts where noted. Glue and screw the dividers between the two sides. Next, attach the top, bottom, center partitions, and cleats. Mount the interior support cleats, allowing about an inch or two of clearance, from top to bottom, between containers. Attach the casters.

Project design: **Bernard Monneau, Calgary, Alta.**



1 EXPLODED VIEW

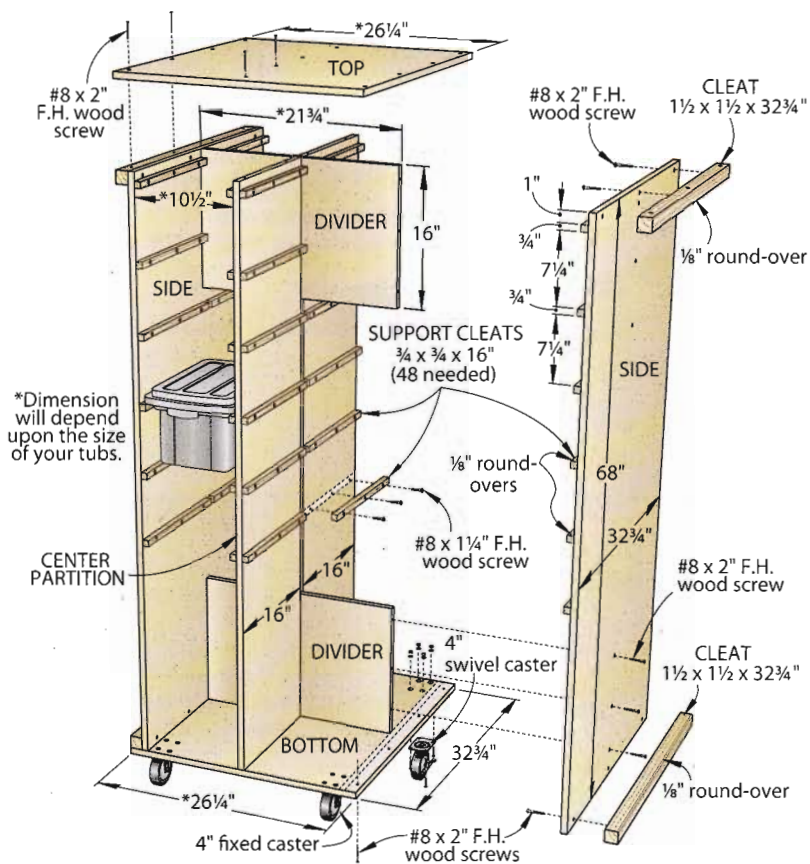

2 CUTTING DIAGRAM

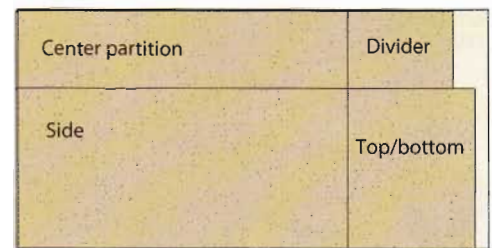

$\frac{3}{4}$ x 49 x 97" Medium-density fiberboard (MDF) (2 needed)

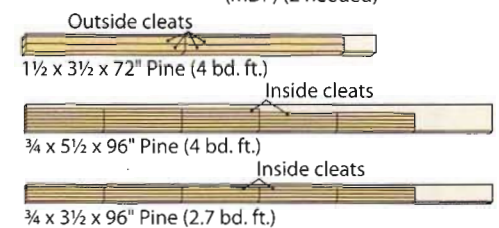

Space-saving hardware bin storage

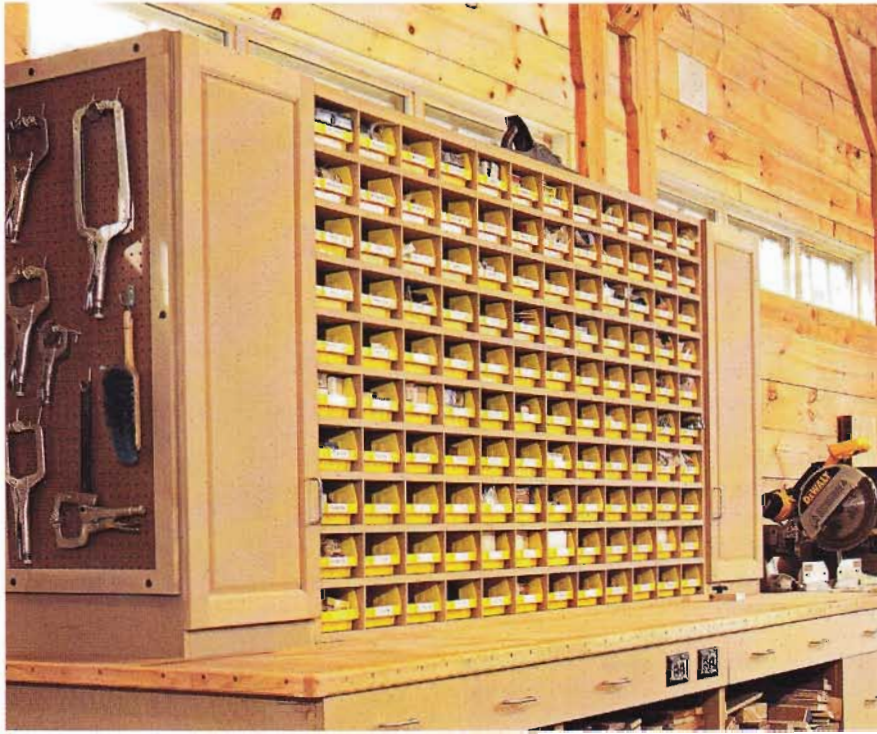

Keep small parts stashed but easy to grab and go when needed.

This hardware storage unit mates a system of removable plastic bins with enclosed storage cabinets, and perforated hardboard panels on each end that keep frequently used tools and accessories handy but out of the way. Although the unit shown at left measures 12' long, sizing one to fit your shop is easy.

A pair of 50 $\frac{3}{4}$ "-tall cabinets with adjustable shelves flank the 120-hole hardware rack. Cubbyholes measure 4 $\frac{1}{4}$ ×6 $\frac{3}{4}$ ×12" to accommodate the size of the plastic bins used here, but adjust yours to match the bins you get. MDF or plywood works equally well for the cabinet: $\frac{3}{4}$ " for the top, bottom, shelves, doors, and sides; $\frac{1}{2}$ " for the cap; and $\frac{1}{4}$ " for the vertical dividers and the back.

Project design: **Mike Connolly, Concord, N.H.**

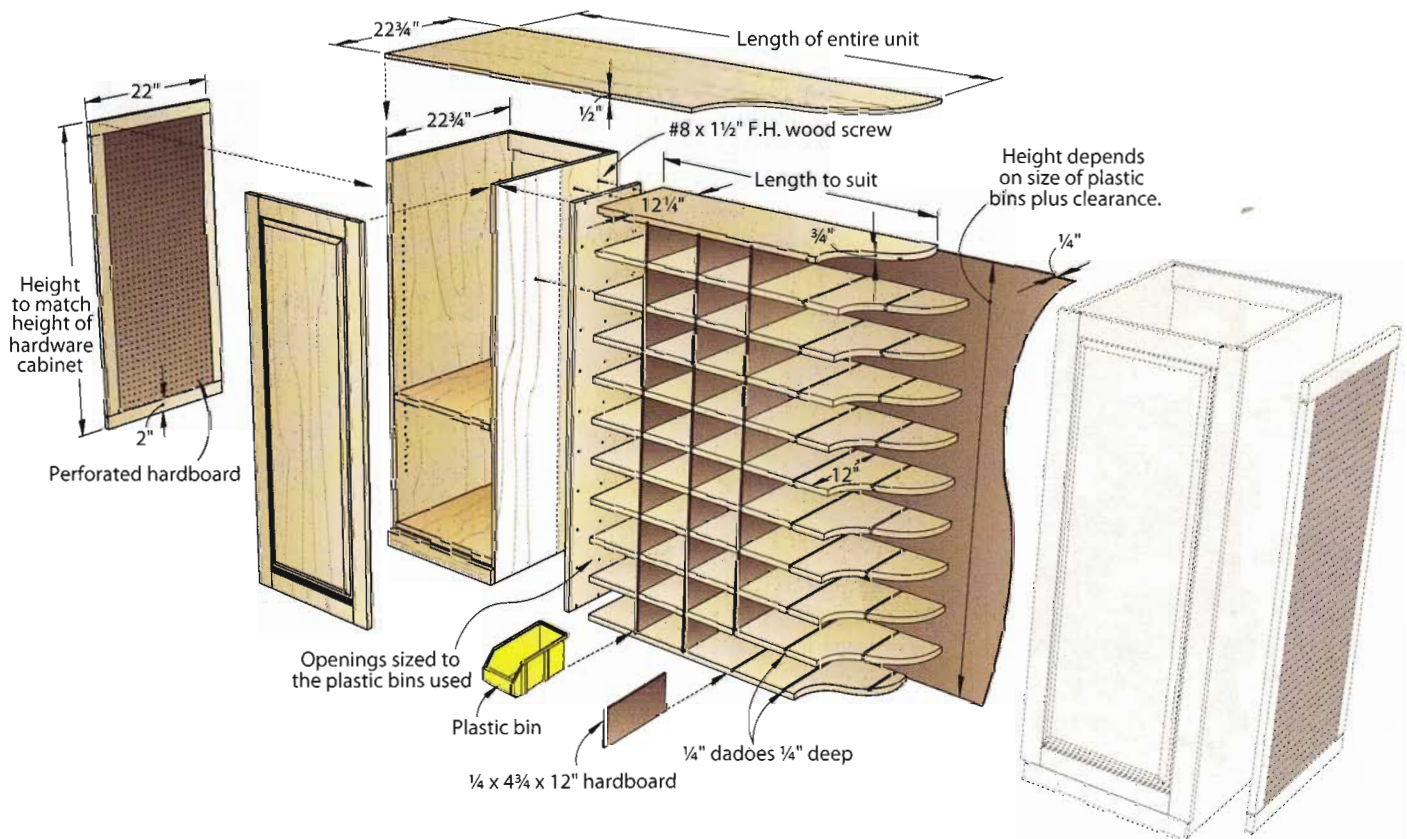

Simple screw-box shelves

If screws come in good boxes, why toss those containers? Store them instead.

The 1-lb boxes that many fasteners come in are almost always the same size, regardless of the number or size of the fasteners they contain. This makes them easy-to-use, serviceable, pre-labeled storage containers. This simple shelf unit holds the boxes for easy access.

It consists of three main components—a back and two sides of $\frac{3}{4}$ " stock with $\frac{1}{4}$ "-deep saw kerfs at 2" intervals. Once you attach the two sides to the back with screws, just slide in some $\frac{1}{8}$ " hardboard shelves to accommodate the boxes.

Most common fastener boxes measure $1\frac{3}{4} \times 3\frac{1}{2} \times 4\frac{1}{2}$ ", so the dimensions shown in the drawing at right should be fine. But adjust your shelf unit as needed.

Project design: **Jeff Feuerstein, Neenah, Wis.**

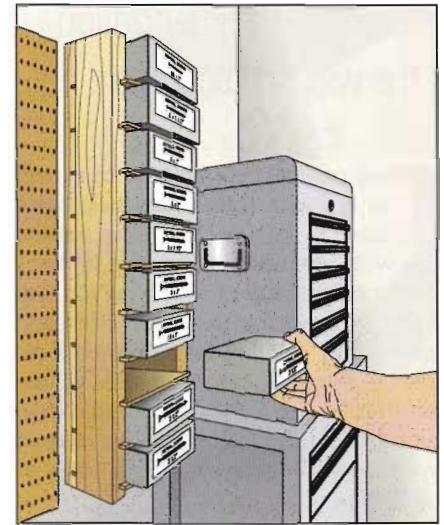
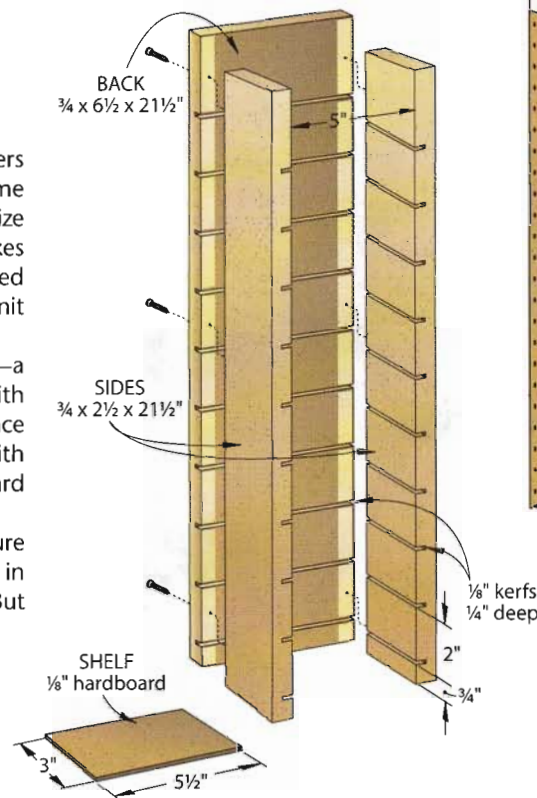

Mobile scrap bin

Roll this easy-to-make cutoff catcher wherever you need it.

This simple but handy scrap cart can roll all over the shop. The sides and bottom are made of $\frac{3}{4}$ " MDF, but plywood works just as well. The removable dividers are $\frac{1}{4}$ " tempered hardboard.

A 24"-long triangular block glued into each corner provides additional strength.

Project design: **Mike Connolly, Concord, N.H.**

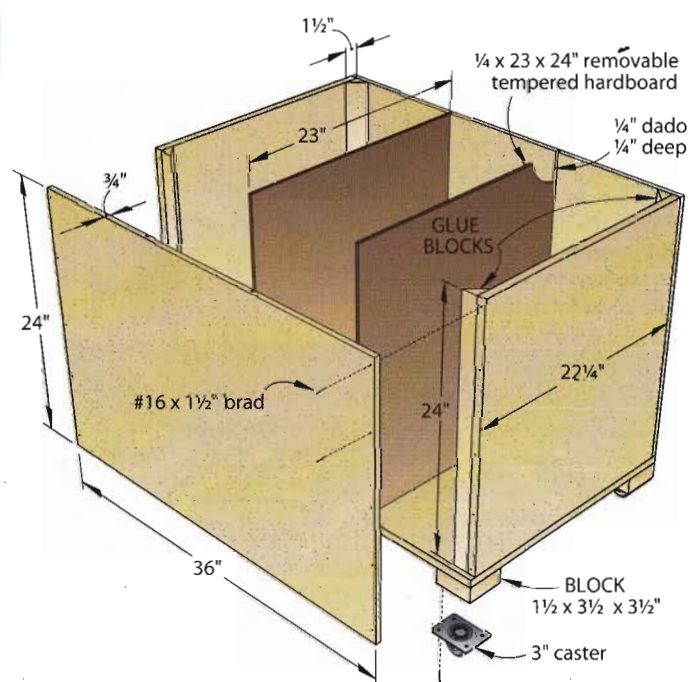

Options for **wall** storage

Sometimes, the key to efficient shop organization is the wall surface itself.

Two products you might not expect to see in a shop could help solve some of your storage issues. For the main walls, consider an exterior ½"-thick siding product called T-111, which has vertical grooves that hide lap joints and requires only painting for a finished look. More important, the thickness of the wood siding makes it more durable than drywall, allowing you to drive screws anywhere without using stud finders or wall anchors.

Most slat-wall systems use aluminum-reinforced horizontal slots in medium-density fiberboard (MDF). Slat wall comes in 4×8' sheets, and securely holds numerous accessories on specialized hangers.

Project design: **John Herboldsheimer, Elizabeth, Colo.**

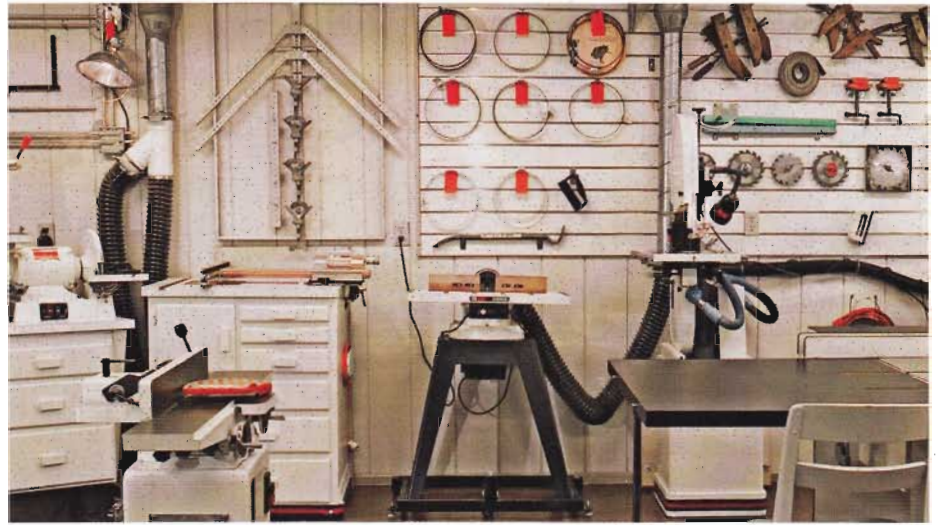

QUICK TIP: BLADE CHANGING

Wedging a tablesaw blade with a piece of scrap when loosening (or tightening) the arbor nut doesn't always hold the blade immobile. Instead, clamp a pair of locking pliers onto the blade near the rim, positioning the jaws to clear the teeth. Brace the pliers against the table. Now, when you apply the wrench to the arbor nut, you won't lose your hold, or skin your fingers, on the blade.

—Jim Prelesnik, Renton, Wash.

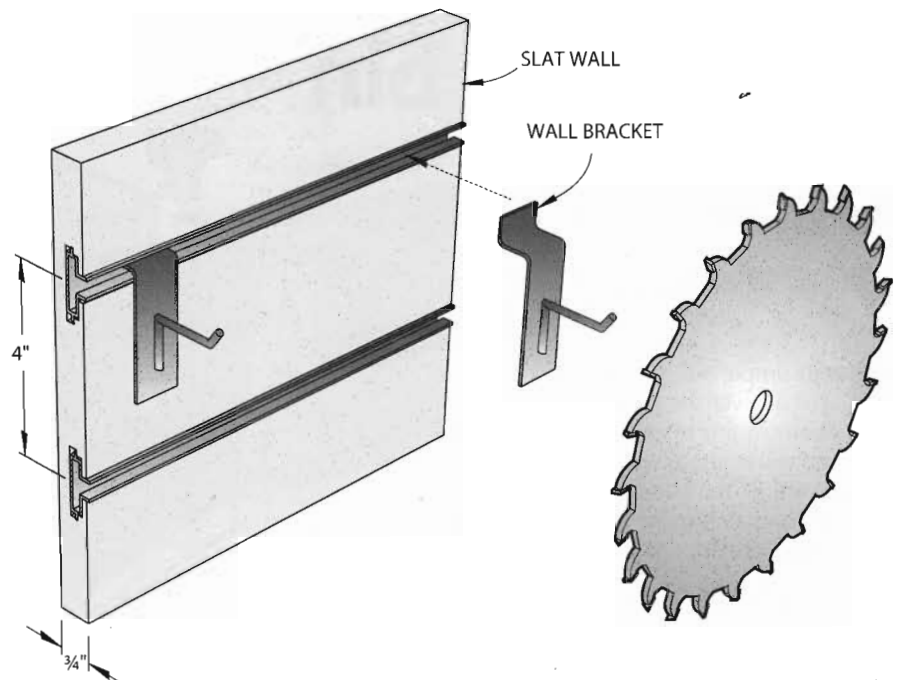

Portable glue/towel center

A helper that's equally at home on a wall or at arm's reach on your workbench.

Hang this handy organizer on a cleat system, and quickly remove it and move it wherever you're working to keep your glue and cleanup supplies close at hand. For this shop aid, cut parts A–D from 1/2" plywood, part E from 1/4" hardboard, part F from 1/2" solid stock, and part G from 3/4" stock to the sizes noted on **Drawing 1**. Refer to **Drawing 1a** for machining the cleat. Cut the dowel groove in the supports (D) to shape. Cut the dados, rabbets, and grooves, where illustrated, in parts A, B, and F. Assemble the unit. Cut a 3/4" dowel to fit between the side pieces and in the dowel groove. Screw the cleat to the back (F) with the top edges of F and G flush.

To learn more about this cleat system, visit woodmagazine.com/cleatsystem

Project design: **Kevin Boyle, Senior Design Editor, WOOD® magazine**



1a CLEAT DETAIL

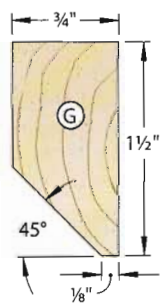

1 EXPLODED VIEW

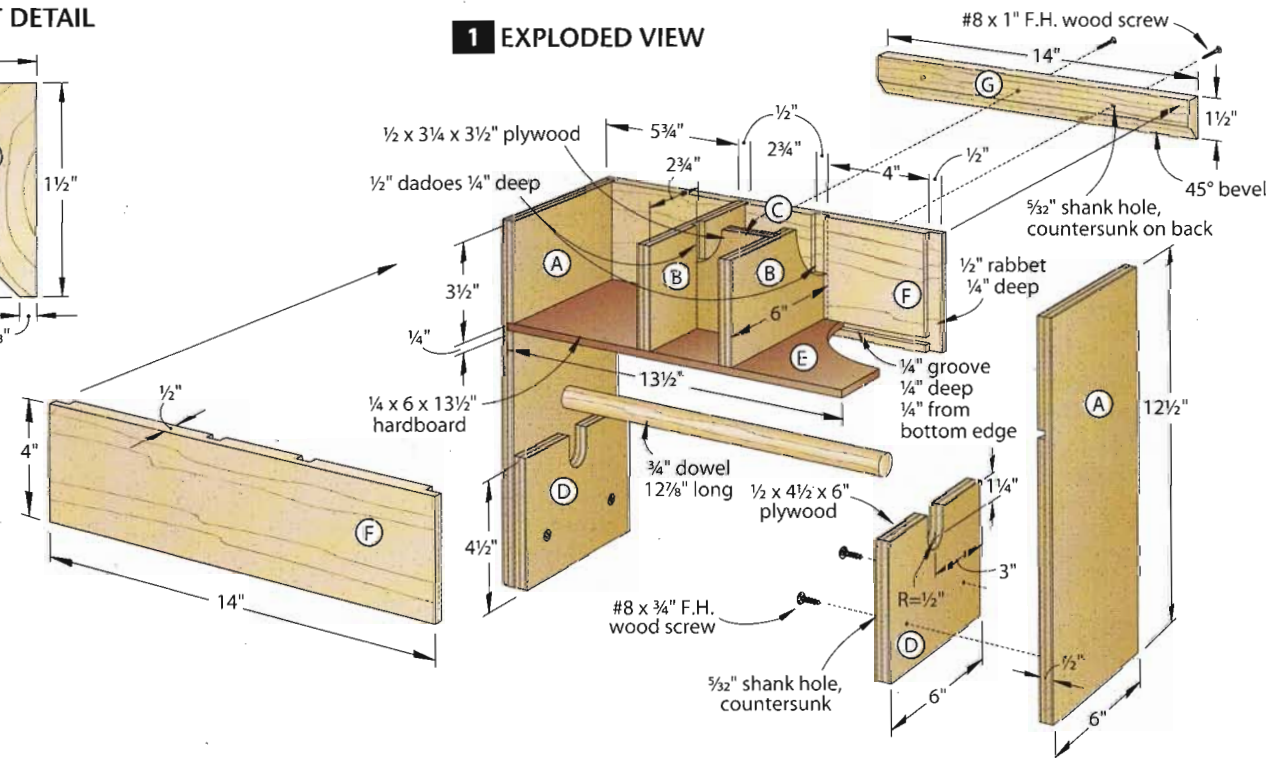

Quick hangers and holders

Try this “inside job” for an easy storage solution.

The inside surfaces of doors on wall cabinets and rolling tool caddies provide convenient places to keep frequently used tools accessible and organized. To hang your tools and keep them secure when doors are opened or when moving tool caddies, you don't need to spend a lot of money on fancy holders. Using small pieces of scrapwood, dowels, and aluminum bar, you can make easy, attractive holders in minutes that customize your tools, such as the ones shown in the photos at right.

Start by removing the doors, placing them on your workbench and laying out your tools on them. Make sure you leave enough clearance around the items for easy handling and door closure. Keep in mind that because fixed cabinet shelves often extend to the front of the carcasses, you need to locate the tool holders either above or below the shelves' edges. Ensure your tools and holders extend no more than 1½" from the doors so they'll clear the drawers and any items on interior shelves when you close the doors.

To allow for easy rearrangement of your tools later, omit glue and simply screw the holders in place. If some of your tools have their own holders, you can mount them to the door instead.

In need of some serious shop organization? Find 17 fast and easy ways to get it done at: woodmagazine.com/organizing

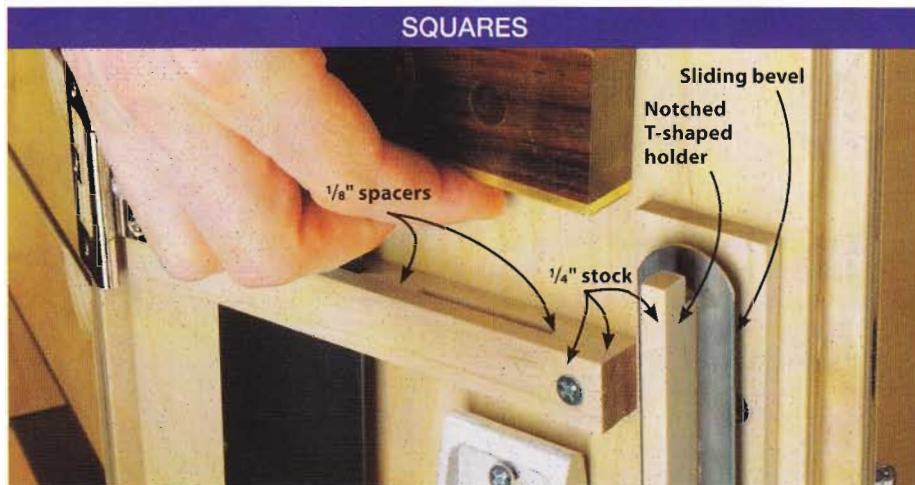

To create narrow slots, glue 1/8" spacers between strips of 1/4" stock. A notched T-shaped holder made from 1/4" stock keeps a sliding bevel securely in place.

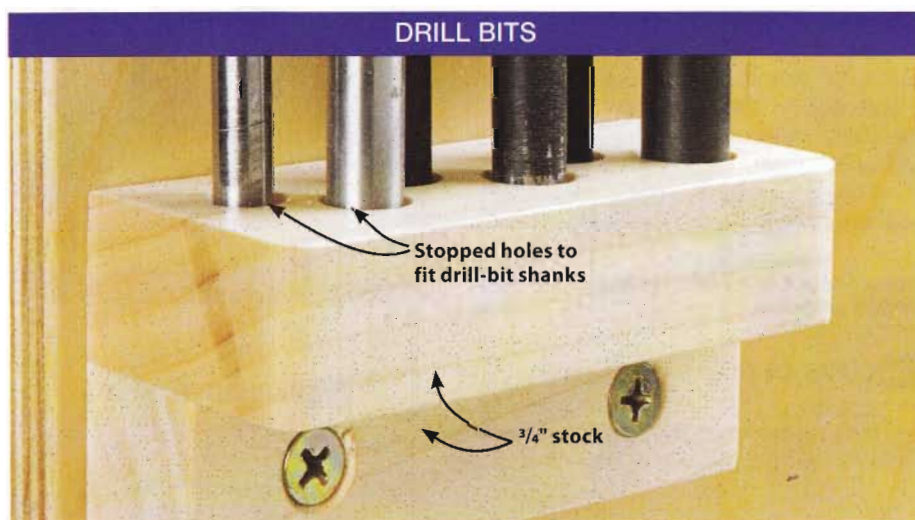

To make a holder for tools that fit in round holes, glue two pieces of 3/4" scrap together. Drill stopped holes slightly larger than the bit-shank or tool diameters.

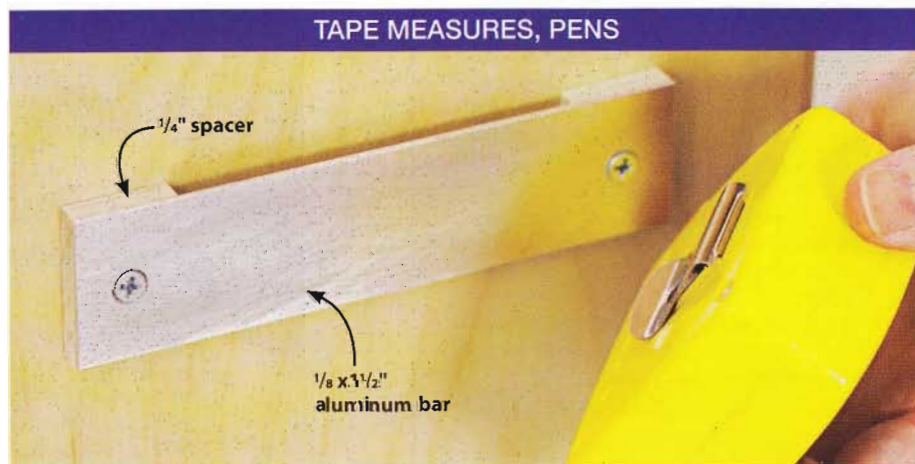

A piece of 1/8x1½" aluminum bar (available at hardware stores) and two 1/4x1½x1½" wood spacers make a handy holder for an item that has a spring clip.

Multipurpose hanger shelf

A hang-anywhere home for easy-to-misplace tools.

Oftentimes, wrenches and other small tools get lost on a cluttered benchtop. This shelf unit with protruding dowels helps minimize clutter. To build it, cut the back, shelf, shelf supports, and spacer to size. Mark the centerpoints of the hanger holes and the dowel locations where shown on the drawing. Drill the hanger and angled dowel holes. Chamfer the hanger holes, shelf, and shelf supports where indicated. Drill mounting holes and glue and screw the shelf to the back. Then, glue the dowels, shelf supports, and spacer in place. The spacer keeps shelves like this tilted backward slightly when hung on a wall, preventing the wrenches from sliding off the front ends of the dowels.

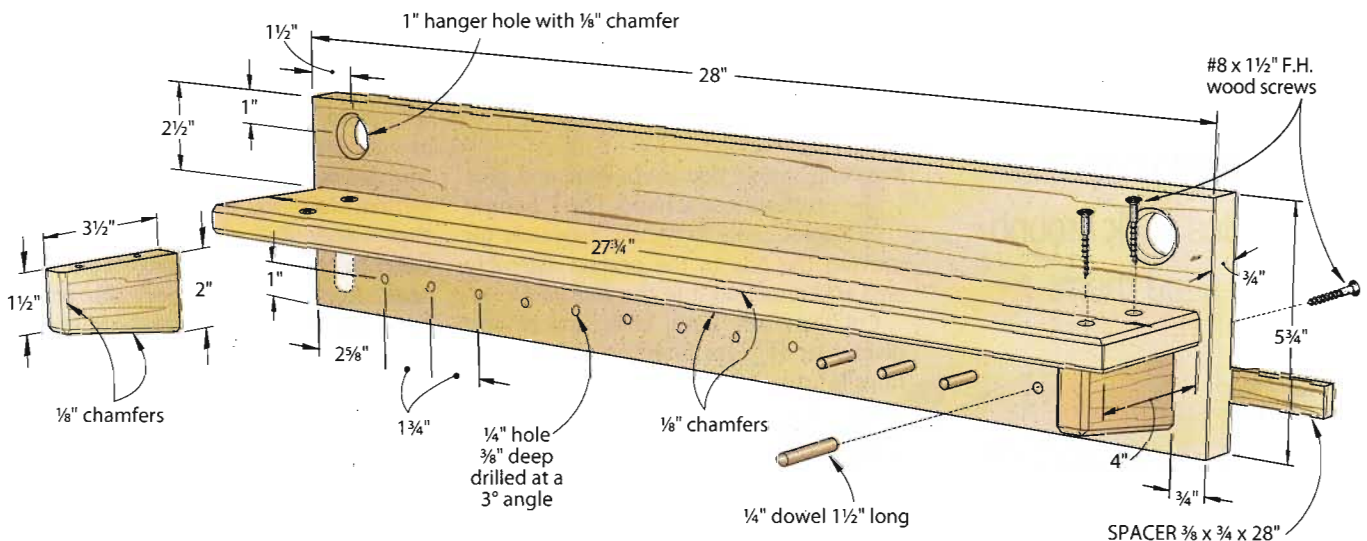

QUICK TIP: MICROWAVE DOWELS FOR A BETTER FIT

Moisture in the air can swell dowel pins so they don't fit. Forcing them into drilled holes runs the risk of splitting the workpiece or breaking smaller dowels. You can remove that moisture and shrink those dowels by placing them on a paper towel or plate inside a microwave oven set on "HIGH" for 30 seconds. Remove, allow to cool and check the dowels for fit. Microwave them for an additional 15 or 30 seconds if necessary.

—From the WOOD® magazine shop

Handy hardware bin

Corral plastic bins for a great small-parts organizer.

Kee loose hardware and screws organized with this holder for plastic hardware bins. First, cut the front, back, ends, and spacer to size from $\frac{3}{4}$ " stock. Adjust component sizes as needed to accommodate your bins. Next, cut the bottom to size from $\frac{1}{4}$ " hardboard. Mark the centerpoints, drill the holes, and chamfer the edges. Then rout or cut $\frac{1}{4}$ " grooves $\frac{3}{8}$ " deep $\frac{1}{4}$ " from the bottom edge of the front, back, and end pieces. Rabbet the front and back where shown. Finally, drill hanger holes and glue and screw the pieces together.

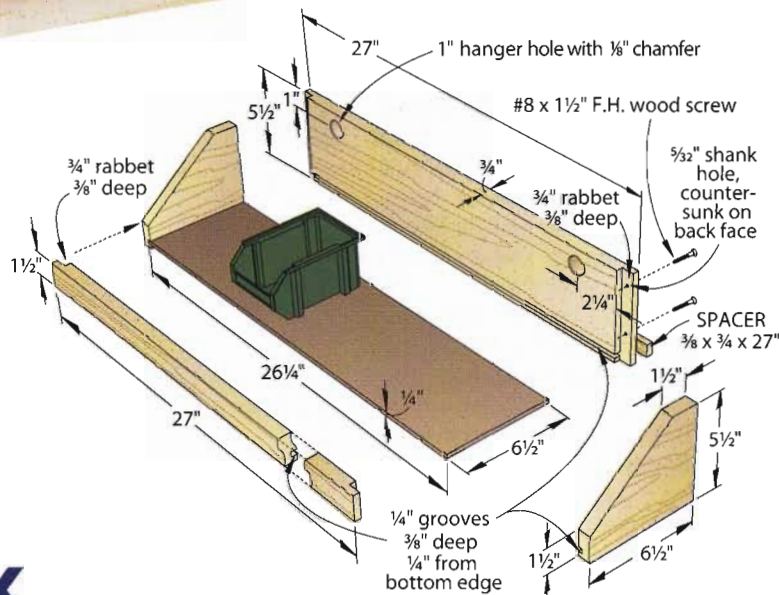
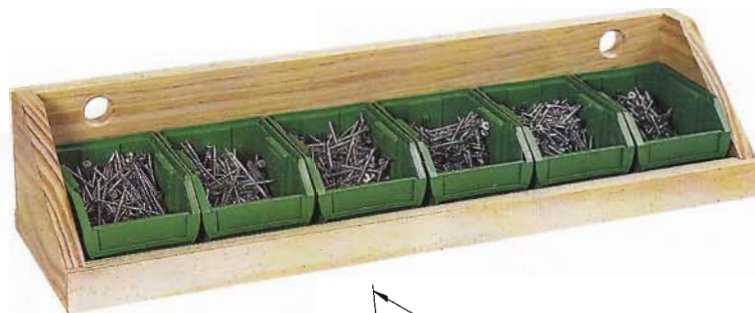

Hanging glue box

A great item to help glue and supplies stick around when you need them.

This simple box keeps glue and glue brushes close at hand. The 1" hanger holes come in handy, especially for moving the box to the project assembly area and returning it to the wall later.

Cut the front, back, ends, spacer, and divider to the sizes listed on the drawing from $\frac{3}{4}$ " stock. Cut the box bottom to size

from $\frac{1}{4}$ " hardboard. Mark the centerpoints on the back, drill the holes, and chamfer their edges. Cut or rout $\frac{1}{4}$ " grooves $\frac{3}{8}$ " deep $\frac{1}{4}$ " from the bottom edges of the back, front, and end pieces to house a hardboard bottom. Rabbet the front where shown. Assemble the pieces and add the spacer to the back.

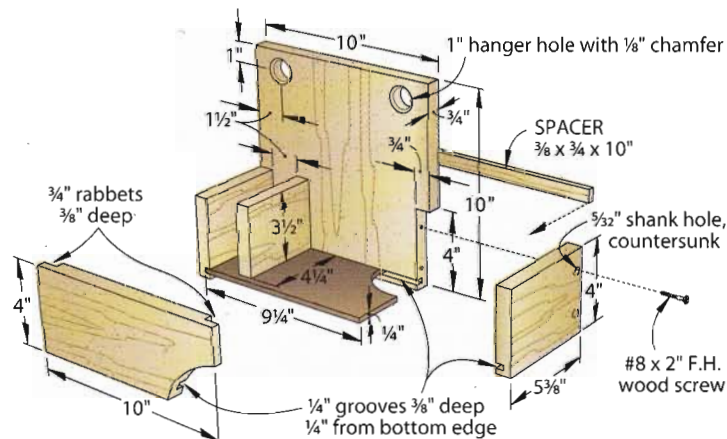

Put the world's best woodworkers in your pocket

What if you could have the world's top woodworking experts teaching you in *your* shop?

Now you can!

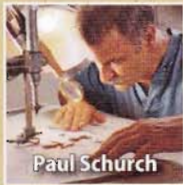

Paul Schurch



Judy Gale Roberts



Marc Adams



Mike Mahoney

Learn cabinetmaking from **Marc Adams** ...Tablesaw tips and tricks from **Gary Rogowski** ...
Veneering and marquetry from **Paul Schurch** ...Woodworking secrets from **Jim Heavey** ...
Turning from **Mike Mahoney** ...Intarsia from **Judy Gale Roberts** ...

Better Woodworking

WOOD Magazine's Video Library

Shop for nearly 100 downloadable videos from top woodworkers.

View them any time on your computer, or take them with you on your iPod or other portable media player.

woodmagazine.com/videos

101BEWP09

Your Best Source for Product Information 24/7!

FREE Product Info

Request woodworking catalogs and product info directly from manufacturers and leading retailers.

Tool Buying Forum

Ask a tool-related question and get an answer within hours.

Tool Reviews

Read summaries of recent WOOD magazine tool reviews.

Money-Saving Tips

Get the most out of your tool-and accessory-buying dollars.

WOODWorkersCenter.com

FREE PRODUCT INFO • LEARN • SHOP

Home Free Product Info Tool Buying Forum Tool Reviews Money-Saving Tips About Us WOOD Magazine

Your ultimate online resource for FREE information and catalog requests for woodworking tools and accessories offered by advertisers featured in WOOD Magazine.

Search WOODWorkersCenter®

Featured Sites

- Traditional Woodworker Corp. For quality hand tools built to last, visit our website to request a free print catalog. Free shipping offer. [more info now](#)
- Eagle America Eagle America proudly offers you the largest selection of professional quality, American-made Router Bits in the industry, but that's not all. [more info now](#)
- PeakTree Woodworking Supply Seller of fine quality woodworking supplies, with a distinct passion as a core vendor in the woodworking industry. [more info now](#)
- Woodworkers Source Over 200 quality woods from around the world. Lumber stock. Quantity discounts. UPS or track shipment. Sets. [more info now](#)
- Woodcraft Supply Over 15,000 woodworking hand and power hardware, exotic woods and more! Top quality exclusives and hard-to-find jigs and accessories. [more info now](#)
- FURNITURE MEDIC Supplies Made in the USA! [more info now](#)

ttrackusa.com
Unique woodworking jigs and fixtures

EAGLE
2,000

Find the best prices on woodworking tools and accessories!

Bandsaw **accessory store-all**

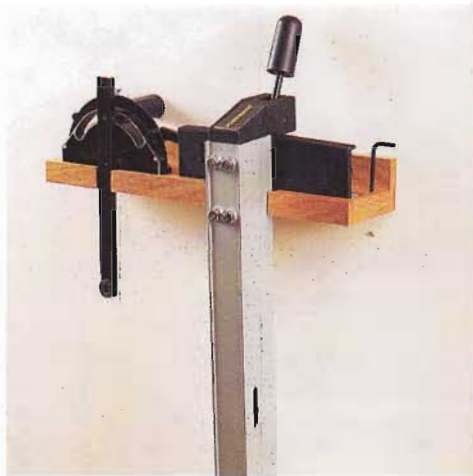

Keep attachments organized and at arm's reach.

When *WOOD*® magazine reader Perry Johnson became tired of playing hide-and-seek with his bandsaw's miter gauge, fence, and smaller accessories, he decided to corral them in a single place. The shelf he came up with is easily customizable to fit your accessories and mounts to your bandsaw in no time. Or, if your bandsaw doesn't sit on an accommodating cabinet, simply create the optional wall bracket and mount the shelf near your saw.

To build the store-all, cut two pieces of 1/2" stock to 3" wide and the length of your bandsaw cabinet. On the top piece, trace the outline of your miter gauge and fence head. Cut the openings slightly oversize and glue the two pieces together to create the base with the recesses. Drill a hole to hold the hex-key wrench used for the guide blocks and another to store the table pin. Cut the 1/2"-thick front strips to hold the fence and miter gauge in place. Glue the strips in position. For a wall-mounted shelf, just cut and add a hanging bracket using glue and wood screws.

Finally, using sheet-metal screws, secure the shelf out of the way on one side of your bandsaw base. Or, if you've opted for a wall location, use wood screws to attach the shelf to the shop wall.

Project design: **Perry Johnson, Minneapolis**

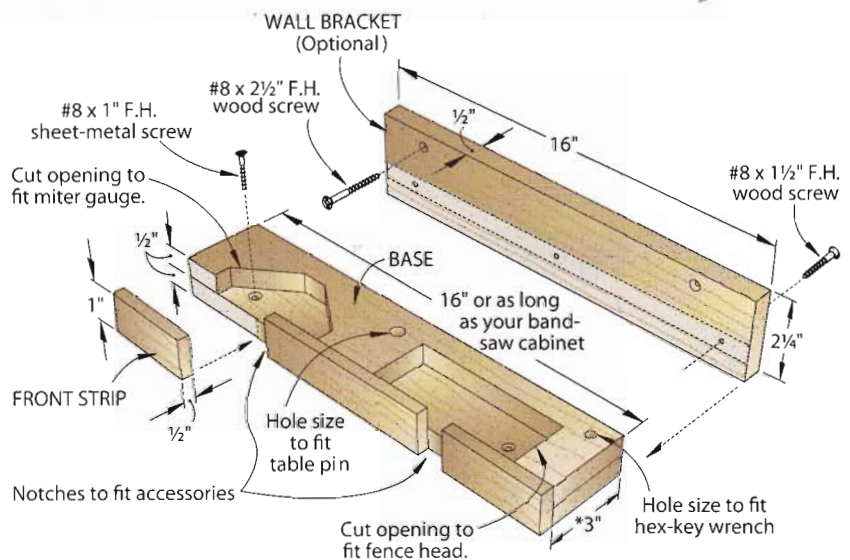
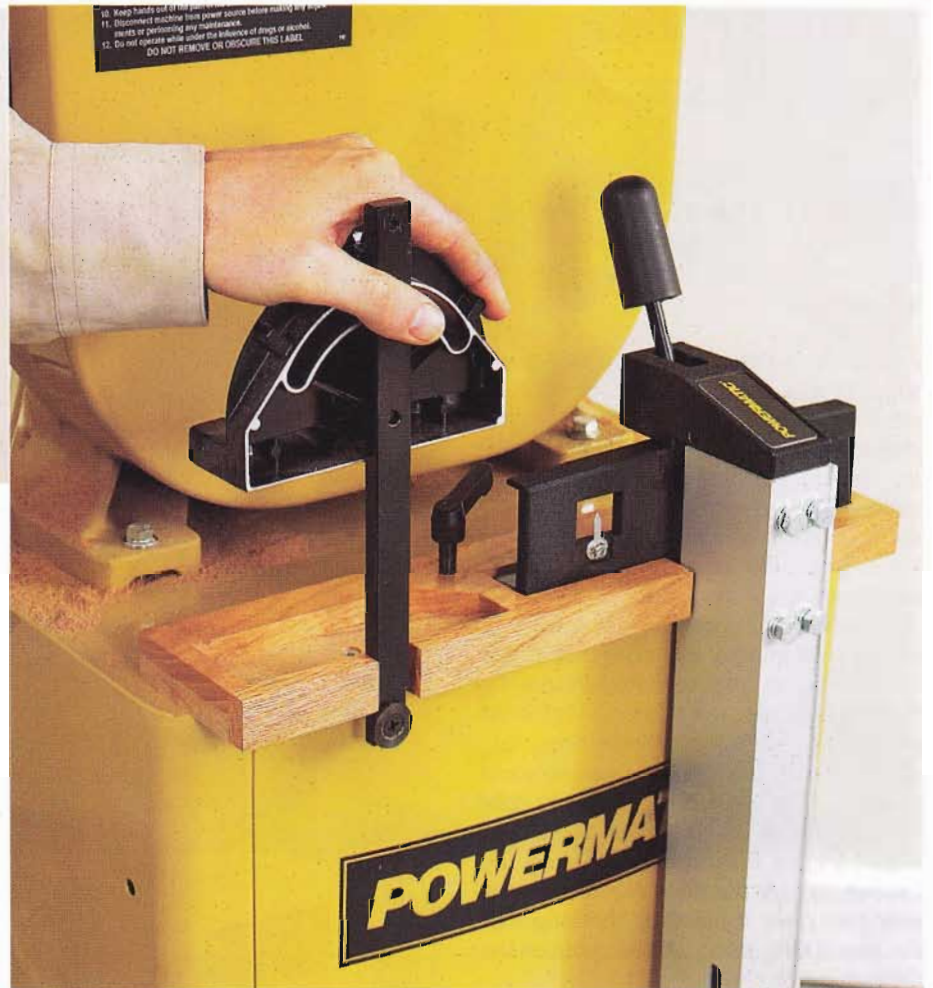

*Expand if necessary for wall-mounted version to allow clearance for miter-gauge handle.

Basic wall cabinet

For shops on a budget, basic is always better.

Most shops require at least some degree of protected storage where dust can't enter. This basic wall cabinet meets that need simply, affordably, and quickly.

Cut the parts shown in the drawing to size. If making a pair of cabinets that will support shelving in between, first determine which cabinet sides will support the shelving. On these sides, drill the holes for the shelf pins all the way through, where shown. This way, the holes can house a shelf pin on either side. Next, drill $\frac{1}{4}$ " holes $\frac{3}{8}$ " deep on the interior faces in each of the opposing cabinet sides.

Assemble the cabinet carcass and dry-fit the $\frac{1}{4}$ " back in place to ensure that it's not so tight as to risk splitting off the lip behind. Then glue the $\frac{1}{4}$ " back into the $\frac{1}{4}$ " groove, and glue and nail the sides, top, and bottom together. To ease assembly and hanging, align and drill pilot holes for door hinges, but don't mount the doors until after hanging the cabinet. To hang the cabinet, attach the cleat (G) to the wall over two studs if possible, checking that the cleat is level. Using a helper, position the cabinet on the cleat.

Using 3" deck screws, secure finished cabinets to wall studs, where shown.

Project design: **Kevin Boyle, Senior Design Editor, WOOD® magazine**

Materials List

Wall cabinet	FINISHED SIZE			Matl.	Qty.
	T	W	L		
A sides	$\frac{3}{4}$ "	12"	30"	MDF	2
B top/bottom	$\frac{3}{4}$ "	12"	23 $\frac{1}{4}$ "	MDF	2
C back	$\frac{1}{4}$ "	23 $\frac{1}{4}$ "	29 $\frac{1}{4}$ "	HB	1
D doors	$\frac{3}{4}$ "	11 $\frac{5}{16}$ "	30"	MDF	2
E* shelves	$\frac{3}{4}$ "	10 $\frac{1}{4}$ "	22 $\frac{3}{8}$ "	MDF	2
F* shelf edging	$\frac{3}{4}$ "	1 $\frac{1}{2}$ "	22 $\frac{3}{8}$ "	PO	2
G wall cleat	$\frac{3}{4}$ "	4"	22 $\frac{1}{2}$ "	PO	1

* Optional shelf and shelf edging quantity, depending on need.

Materials key: MDF—medium-density fiberboard, HB—hardboard, PO—poplar.

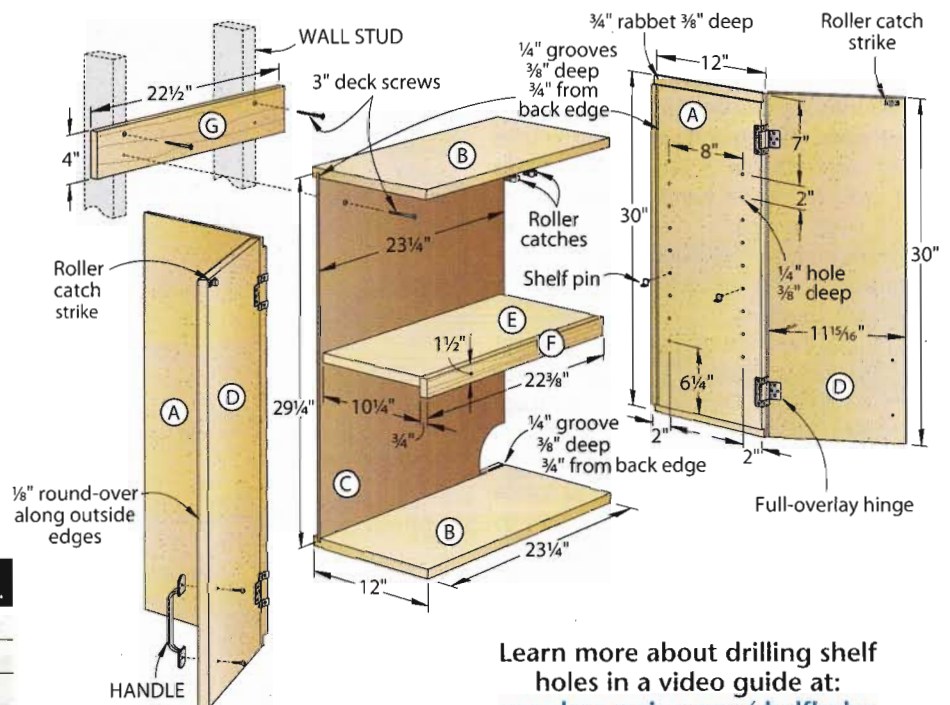

Learn more about drilling shelf holes in a video guide at: woodmagazine.com/shelfholes



Easy-access router-bit storage

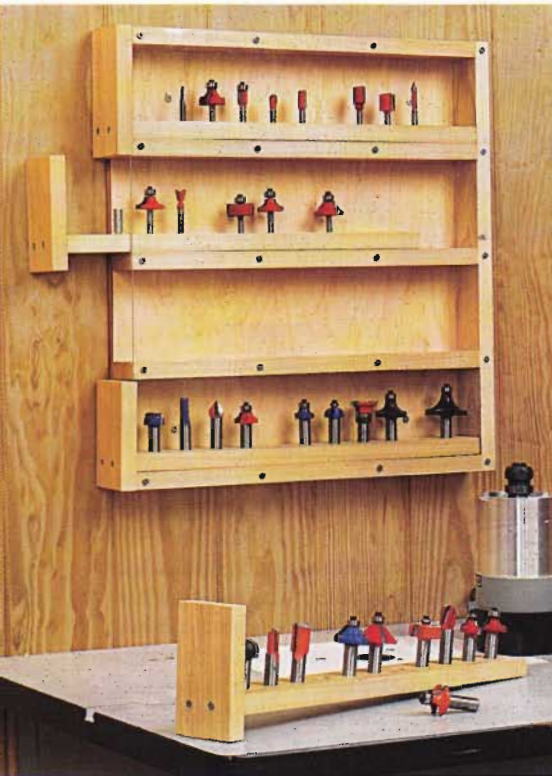

Combine pullout shelves with a clear-view window in one well-ordered cabinet.

To keep router-bit storage close at hand, this organizer works equally well attached to the side of your freestanding router table or mounted on the wall. The handy storage unit's four slide-out shelves make it easy to securely carry a variety of router bits anywhere you're working in the shop.

To construct the unit, cut the back, support, five dividers, and acrylic front to size. (We cut the 1/8"-thick clear acrylic with a 60-tooth, triple-chip carbide-tipped blade.) Countersink the mounting holes in the acrylic so the screw heads don't protrude. Assemble the unit in the configuration shown in **Drawing 1**, using just four screws to temporarily attach the acrylic front panel to the cabinet.

Cut the four hardwood shelves and ends (one tall and three short) to size. Drill holes in the shelves to house your router-bit

collection. Drill mounting holes and screw the ends to the shelves [**Drawing 1a**]. The finished shelf assemblies simply slide on top of the dividers for ease in construction and use.

For mounting, remove the acrylic panel from the front of the assembly and drill four mounting holes through the plywood back. Screw the assembly to studs in your shop wall or to the side of your router table, and screw the acrylic panel to the dividers.

Project design: **David Riel**,
Huntington Beach, Calif.

Find numerous videos on using routers at:
woodmagazine.com/routertips



1a TOP SECTION VIEW

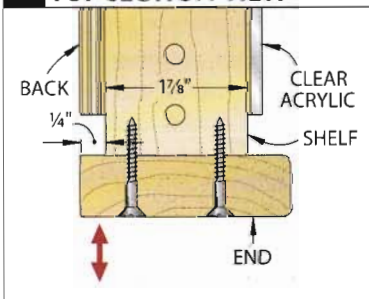

1 EXPLODED VIEW

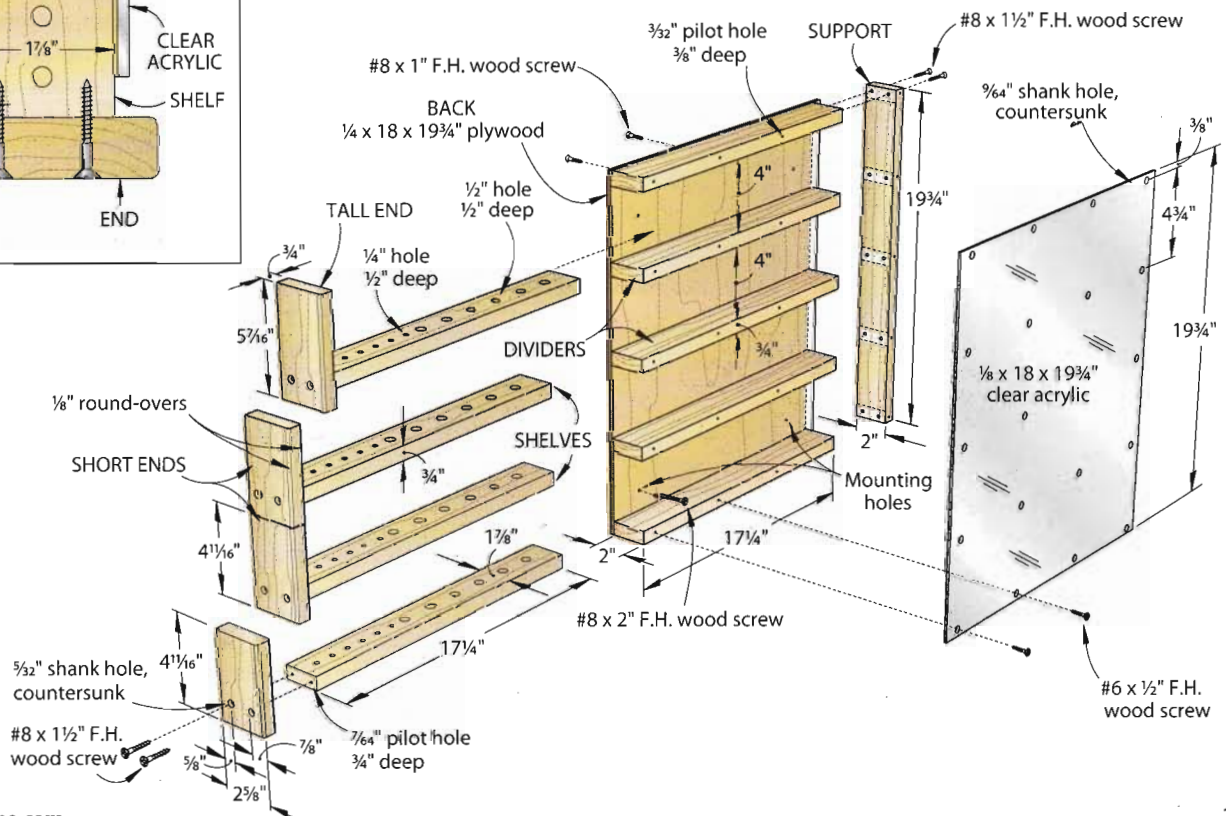

Router-bit display organizer

The best edge treatment is but a glance away.

See instantly what profile each of your router bits create by building this handy bit display with matching profiles. You can set the bit support on your workbench or build the optional wall mount. The bit support shown measures 8" long, but can be altered to hold as many bits and profiles as you need to store. Add 1 1/2", on average, for each additional bit. (For large-diameter bits, such as a panel raiser, lengthen the support even more; for smaller-diameter bits, an extra inch per bit should suffice.) We built our wall mount extra long for adding more bit supports.

To form the angled support for the bits, start with a piece of 1 1/4 x 2 1/4 x 8" stock. Using a pushstick for safety, bevel-rip the strip at 18°, and use cloth-backed double-faced tape to stick the two pieces together in the configuration shown in the photo at

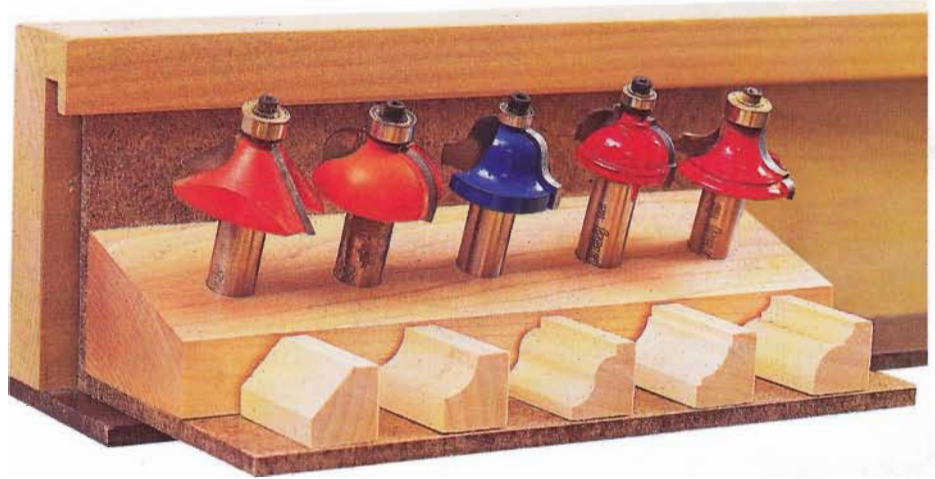

bottom left. Then, drill 1/2" holes 1/2" deep into the support and separate the support from the waste stock.

To create a profile for each bit you'll house in the bit support, cut blanks 8" long and drill a 1/4" hole centered side to side and 1/2" from one end. Now, rout each 8"-long blank with a different bit. Crosscut a 1"-long section from the drilled end of

each blank and glue in a piece of 1/4" dowel 1/2" long in the previously drilled hole. The profiles detach from the base so you can hold them up to an edge requiring routing. The support also gives you the flexibility to replace bits and move them as needed.

Project design: **Kevin Boyle, Senior Design Editor, WOOD® magazine**

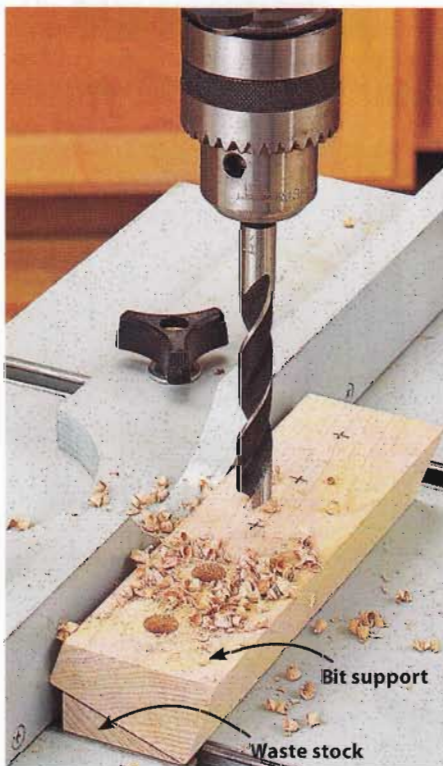

Stick the waste stock to the bit support, and drill the 1/2" holes.

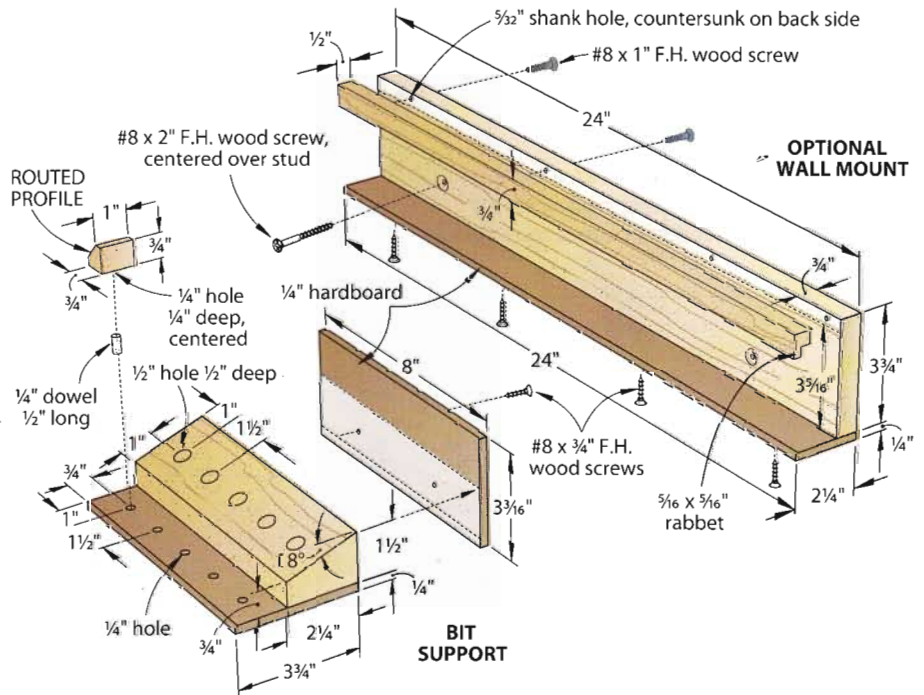

Round and ready **drill-bit carousel**

This rotating organizer goes wherever you need it.

Want to keep large drill bits and other hole-boring accessories close at hand and easy to find? This compact carousel holds a multitude of specialty bits, such as holesaws and Forstner bits, and swivels on a lazy-Susan bearing for quick access.

To build one, use a compass to mark three 5"-radius circles on 3/4" plywood. Bandsaw and sand the discs to shape. For the top, locate and mark the nine curved

slot locations [Drawing 1a]. Drill 5/8" start holes for the outside and middle slots and 3/8" start holes for each inside slot. Then, scrollsaw or jigsaw between the holes to form the slots. Drill 5/8"-deep holes in the shelf to fit the shanks of your bits and accessories and a 1/2" hole through the base for screw access.

Crosscut the dowels to length. Create a collar with a 3/4" hole in it. Assemble the unit [Drawing 1] and attach the bearing to the base, using the 1/2" access hole in the base to drive the screws into the shelf.

Project design: **Jim Harrold, Norwalk, Iowa**

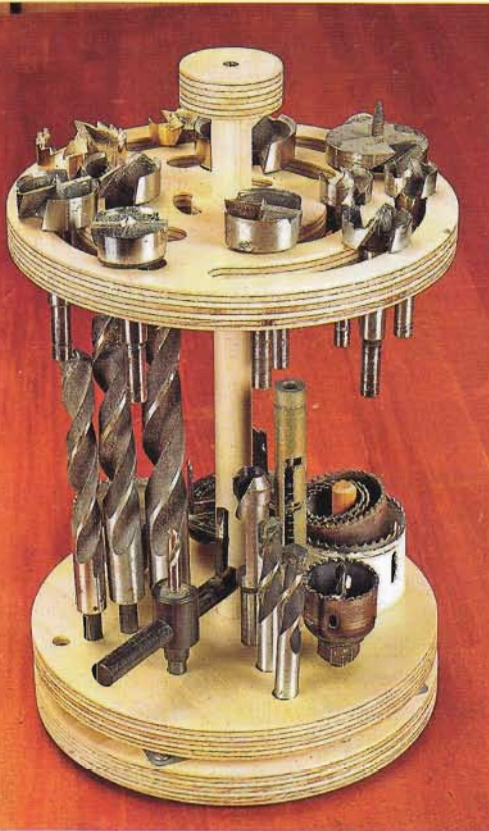

1 EXPLODED VIEW

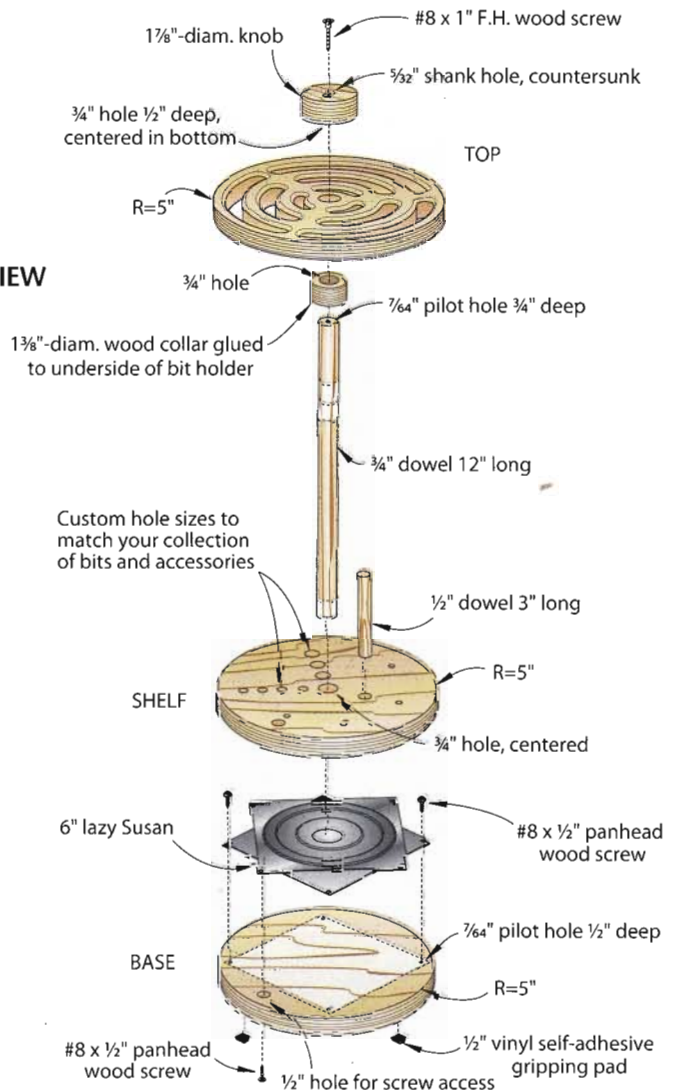

1a TOP DETAIL

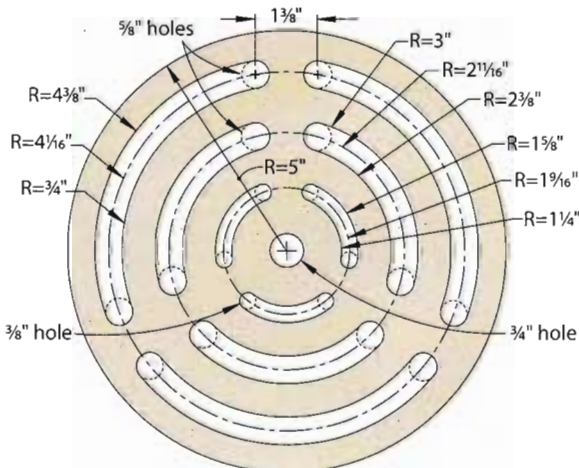

Workshop **drawer organizer**

Keep small tools and accessories in this convenient lift-out box.

No matter the size of your shop drawers, this compartmentalized box keeps everything tidy. If need be, you can remove the box quickly to wherever you're working.

To build an organizer, first measure the width of the drawer you want the insert to fit. Make the overall width of the organizer $\frac{1}{4}$ " less than the interior of the drawer. To accomplish this, measure the interior of the drawer (side-to-side) and cut the front and back (A) to this size minus $\frac{3}{4}$ ".

Cut the sides (B) and bottom (C) to size. Cut the grooves, dadoes, and rabbets in parts A and B, where dimensioned.

Clamp the pieces together and cut the divider (D) to fit. Cut the drill-bit holders (E) to size, bevel-ripping one edge at 30° where shown, at right. Drill holes in the holders to fit your bit shanks. Drill mounting holes and screw the holders (E) in place to the box bottom (C). We did not glue the holders (E, F) in place so we could resize or relocate them later. Cut the holders (F) to fit and drill shank holes in them. With assembly complete, apply a clear finish to the insert and fit it into place.

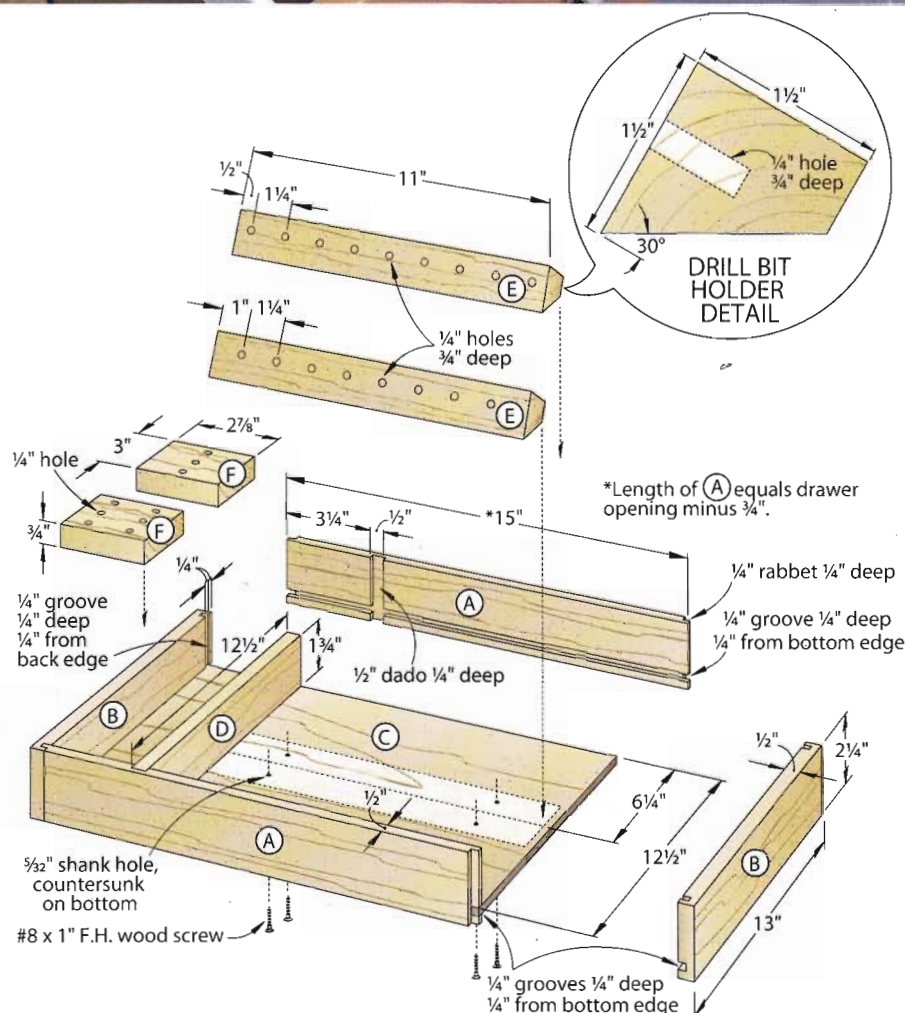

Project design: **Kevin Boyle, Senior Design Editor, WOOD® magazine**

Materials List

Wall cabinet	FINISHED SIZE			Matl.	Qty.
	T	W	L		
A front and back	$\frac{1}{2}$ "	$2\frac{1}{4}$ "	*15"	M	2
B sides	$\frac{1}{2}$ "	$2\frac{1}{4}$ "	13"	M	2
C bottom	$\frac{1}{4}$ "	$12\frac{1}{2}$ "	15"	P	1
D divider	$\frac{1}{2}$ "	$1\frac{3}{4}$ "	$12\frac{1}{2}$ "	M	1
E* bit holders	$1\frac{1}{2}$ "	$1\frac{1}{2}$ "	11"	M	2
F* small holders	$\frac{3}{4}$ "	3"	$2\frac{7}{8}$ "	M	2

*Length of A equals drawer opening minus $\frac{3}{4}$ ".

Materials key: M—maple, P—plywood.

Supplies: 8x1" flathead wood screws.

Simple saw-blade protector

Protect cutting edges and avoid expensive replacement by separating your blades.

This drawer built under a tablesaw extension table has specially made dividers separating saw blades. The design of the plywood dividers makes individual blades easy to grip and remove. The dividers also act as shields to prevent the blades from banging against each other.

The dividers fit in $\frac{1}{4}$ " grooves cut into $\frac{3}{4}$ " medium-density fiberboard (MDF) front and back pieces, but plywood would work just as well. Rip the grooves in the stock as one workpiece, then cut the stock in half to give identical front/back pieces sized to fit your drawer, as shown in **Drawing 1**. The dividers [**Drawing 1a**] slip in so you can remove them to retrieve foreign objects or for vacuuming.

Project design: **John Herboldsheimer, Elizabeth, Colo.**

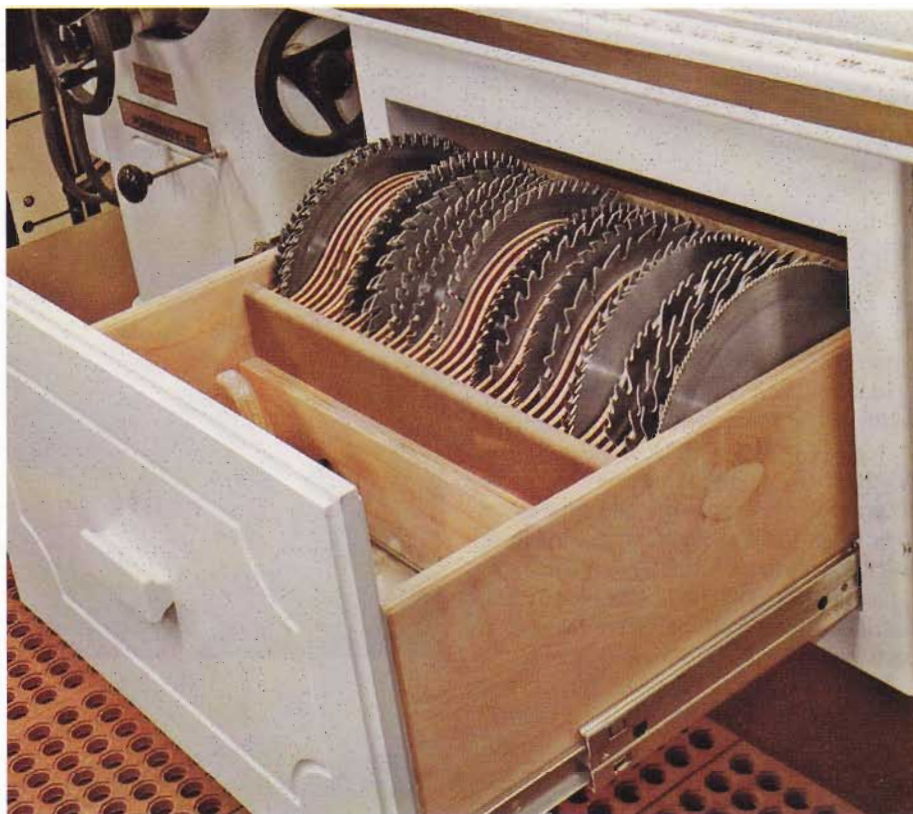

1 HOLDER PLACEMENT

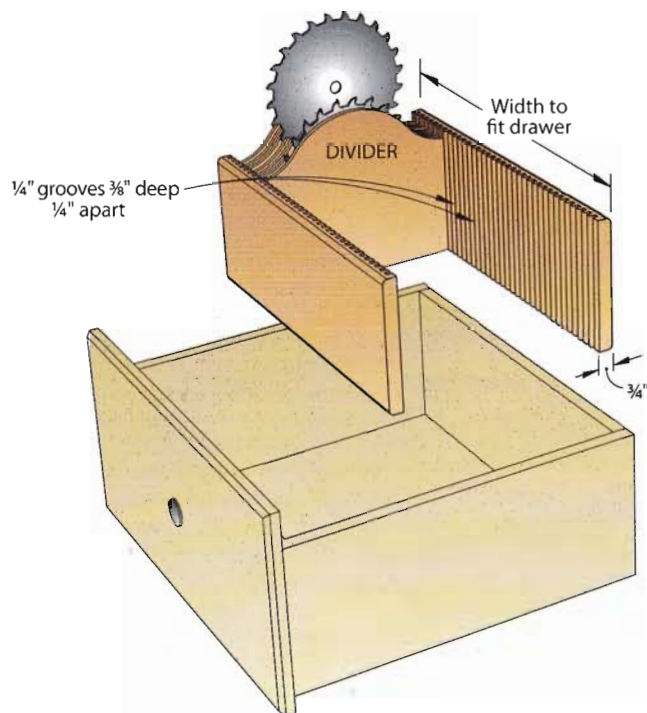

1a DIVIDER PATTERN

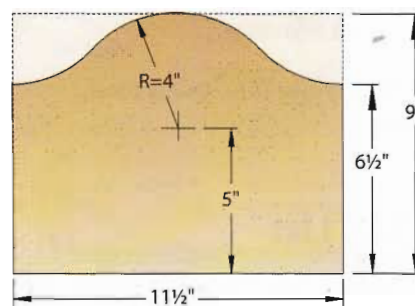

QUICK TIP: SAW-BLADE SAFETY

It only takes one slip when changing tablesaw blades to incur a nasty gash. To help move your hand out of the line of fire, bend your blade wrench. Place the midpoint of your wrench handle in the jaws of a machinist's vise and tap the wrench with a hammer until it's bent about 30°.

—Bill DeSoto, New Iberia, La.

Multipurpose sandpaper tote

Save time with this combo storage and cutting center.

The handle on top of this convenient sandpaper tote makes quick work of halving or quartering sandpaper because the distance between the edge of the handle and the hacksaw blade screwed to the outer edge is exactly half the size of a standard sheet of sandpaper. Individual shelves are marked to separate grits and grades. To make a similar sandpaper tote, see the illustration and accompanying **Materials List** below.

For the sandpaper cutters, grind or cut one end off a hacksaw blade. Drill a $\frac{3}{16}$ " mounting hole into the trimmed end and one in the center of the blade—no need to drill a third hole, as it's already on the end of the blade. Mount the blade with teeth $\frac{1}{32}$ " above the top surface of the box. (Two blades are required, one on each side; only one shown.)

Project design: **John Herboldsheimer, Elizabeth, Colo.**



Materials List

Part	FINISHED SIZE			Matl.	Qty.
	T	W	L		
A sides	$\frac{3}{4}$ "	10"	13 $\frac{1}{2}$ "	PL	2
B top & bottom	$\frac{3}{4}$ "	10"	12 $\frac{1}{4}$ "	PL	2
C shelves	$\frac{1}{8}$ "	10"	12 $\frac{3}{16}$ "	H	7
D back	$\frac{1}{8}$ "	13"	13 $\frac{1}{2}$ "	H	1
E stiles	$\frac{1}{4}$ "	$\frac{3}{4}$ "	13 $\frac{1}{2}$ "	B	2
F rails	$\frac{1}{4}$ "	$\frac{3}{4}$ "	13"	B	2
G tearing guides	$\frac{1}{4}$ "	$\frac{3}{4}$ "	10"	B	2

Materials key: PL—plywood, H—hardboard, B—birch.
Supplies: #4x $\frac{1}{2}$ " panhead screws, #8x $\frac{3}{4}$ " roundhead brass wood screws, $\frac{1}{2}$ " brads, 10 $\frac{3}{8}$ " hacksaw blades (2).

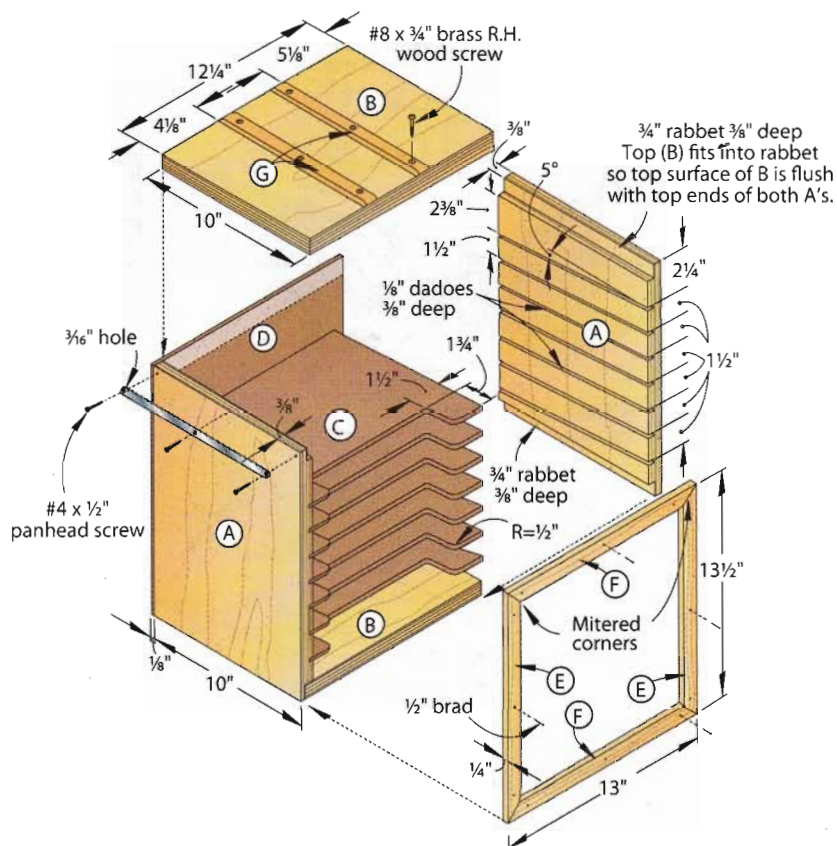

Benchtop sanding-disc caddy

Store, wrap, and tote your sanding needs with this single portable unit.

The horizontal layout of this nifty sandpaper holder maximizes both space and organization. Hook-and-loop sanding discs stand on edge within their own compartments, separated by $\frac{3}{16}$ " hardboard dividers that slide neatly and snugly into dados on the top and bottom shelves. Self-adhesive rolls wrap around the long dowel on the top, while abrasives for a detail sander stack up on vertically oriented dowels glued into holes on top of the caddy.



Project design: **Walt Segl, Pleasant Valley, Pa.**

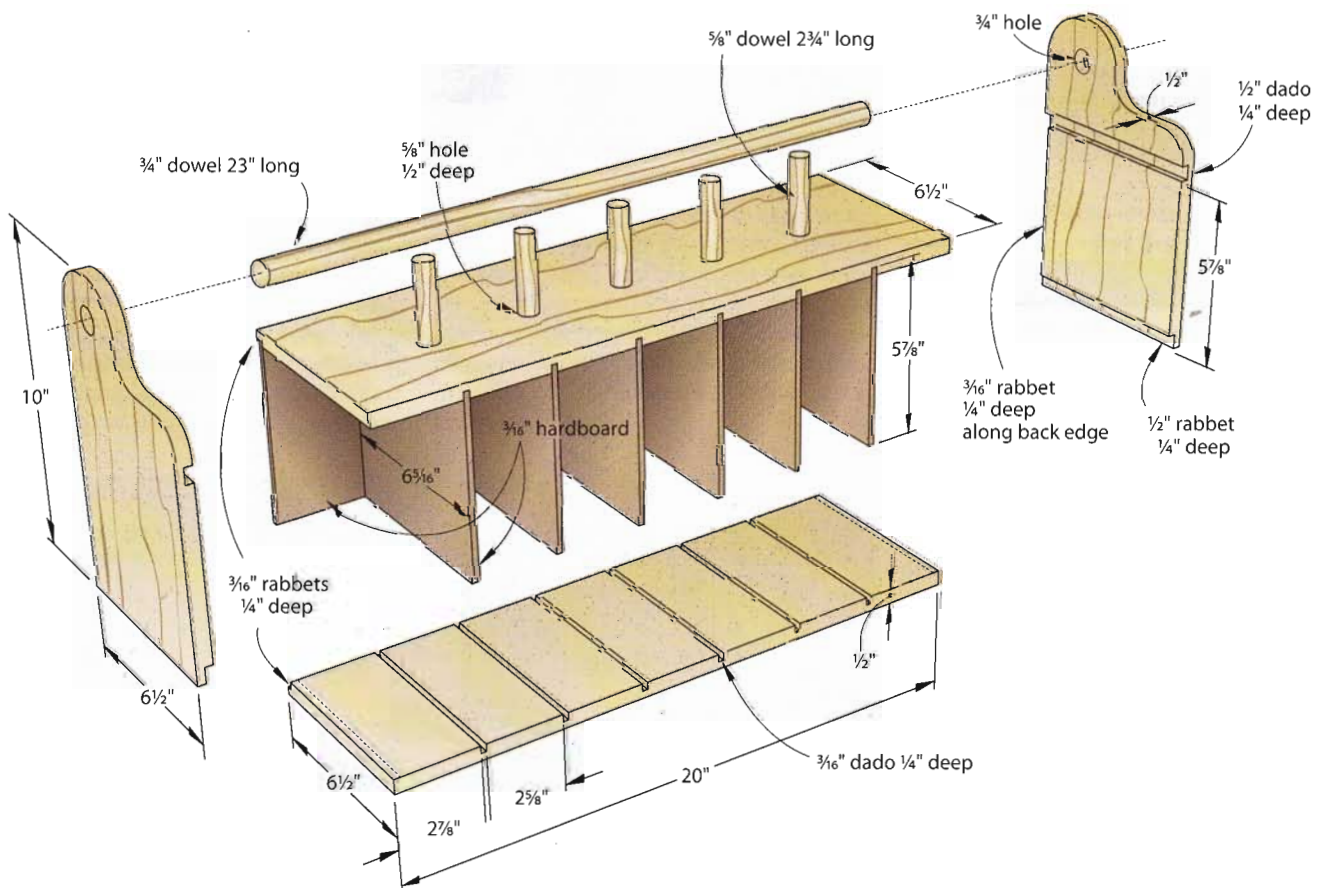

Random-orbit sander center

Home sweet home for both tool and sanding discs.

A perfect project for a free afternoon, this compact organizer takes no more than a couple of hours to complete. Shelves slide into dados cut into each side of the unit. Using lighter-weight wood will allow it to hang on any wall (screwed into wall studs), and a coat of dye or stain adds a touch of color to the finished project.

If you have more than one sander, you could make the upper portion of the sander center taller for a second shelf that accommodates the additional tool. 🌲

Project design: **Sam Daigle, Bathurst, N.B.**

Editor's Choice

I can never find the right sanding disk when I need it, and this sander center is the perfect solution for keeping everything sorted and in one spot!

A.J.H.

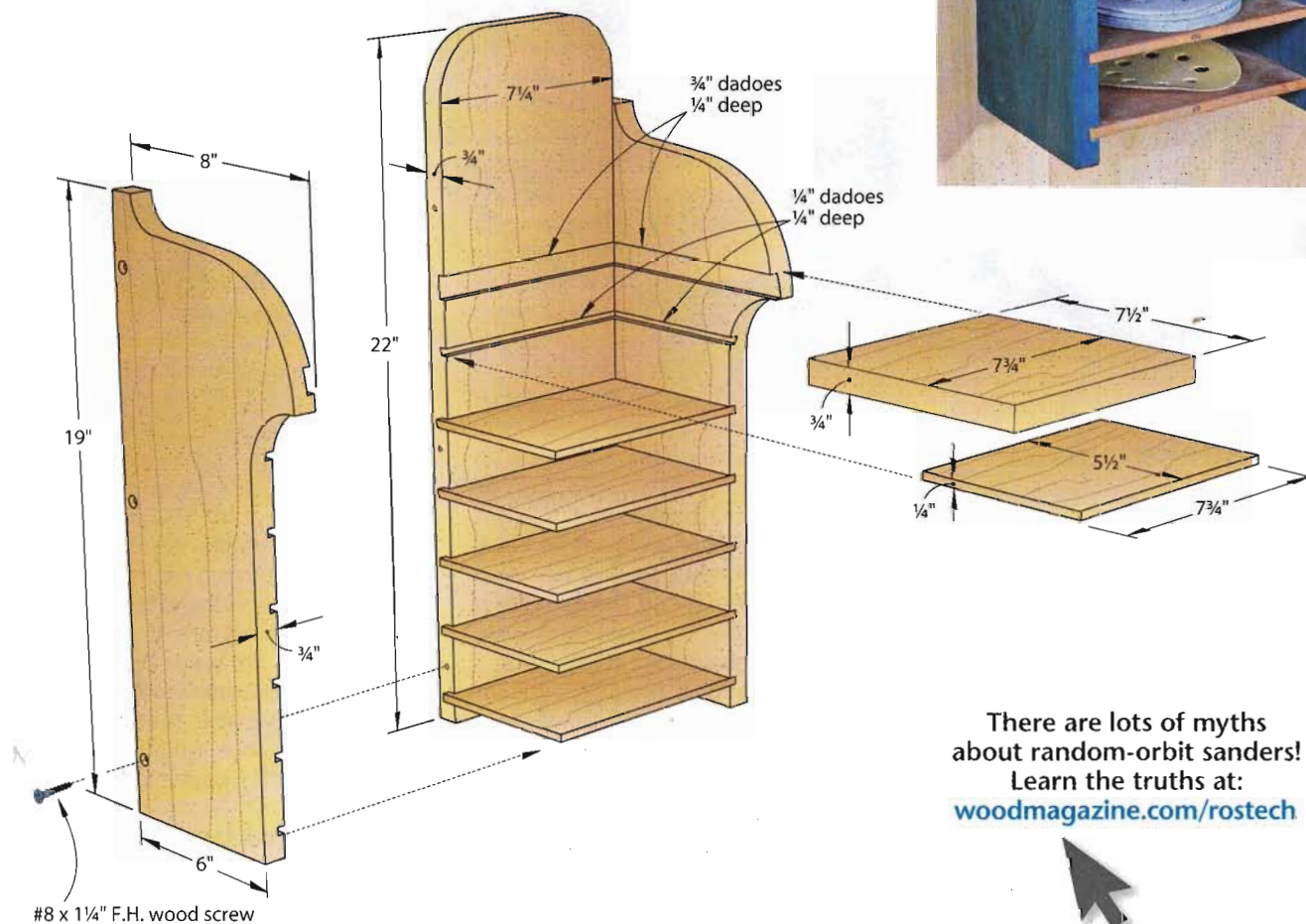

There are lots of myths about random-orbit sanders! Learn the truths at: woodmagazine.com/rostech



TIP OFF THE OLD BLOCK Easy and quick to make, sometimes the smallest shop jigs and fixtures make the best problem solvers.

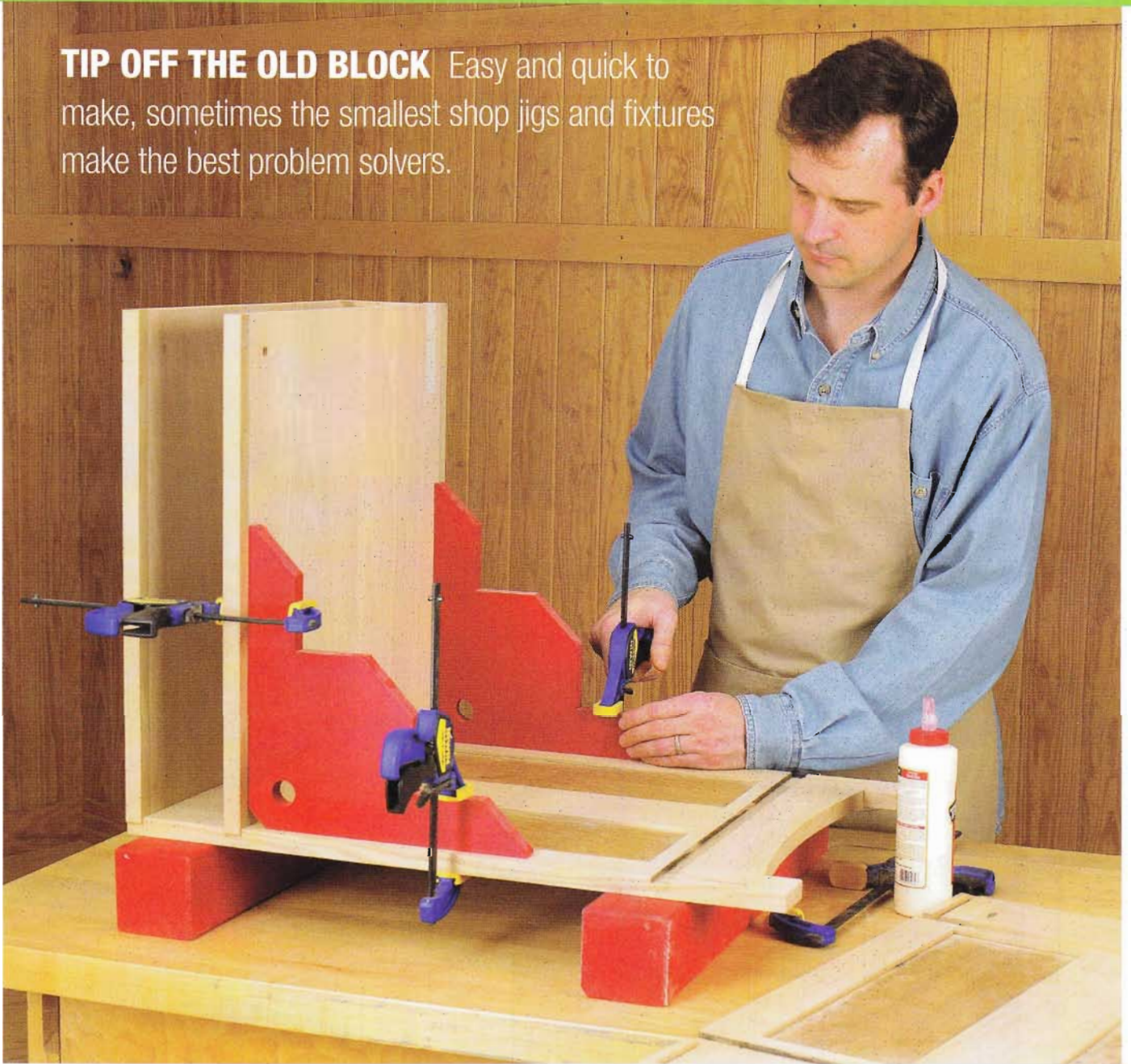

Squaring braces speed carcass assembly

Here's an easy way to square a carcass during assembly. Make four of these squaring braces, shown in the drawing at right. Then, when you assemble carcass panels, position a brace in each corner and clamp it to adjoining panels to square them, as shown in the photo, above. Be extremely careful when making the braces to ensure they are perfectly square and true. Of course, the beauty of it is that you'll only have to do it once.

—The Editors of WOOD® magazine

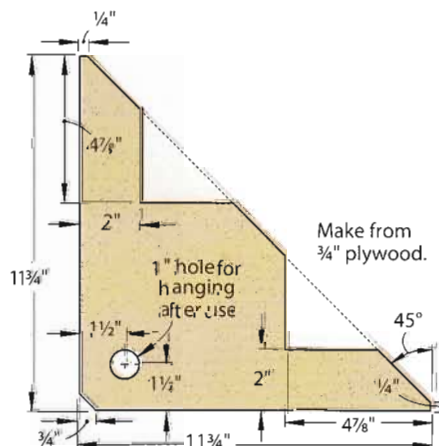

Sacrificial insert saves sled's integrity

My tablesaw crosscut sled has been one of the most useful tools in my workshop. However, I've also found that unless I use the same blade each time, the kerf widens and I can't rely on the sled anymore for chip-free cuts. And I can't make bevels or dado cuts without trashing the sled. My solution was to create sacrificial inserts that cover both cutting areas of the saw.

To apply this idea in your shop, first determine the maximum cutting width of the saw from a 45° bevel cut to a full dado stack at 0° bevel. Then, set back the 1/4"-plywood sled bed 3/4" from each side to create a shoulder for the insert. Do the same thing to size and locate the vertical sacrificial insert for the rear fence. Attach the inserts with wood screws, being sure to keep the screw heads below the surface of the insert so they won't accidentally scratch a workpiece.

You can now install different inserts for each blade, bevel angle, or dado size. When either insert no longer provides the needed zero-clearance, simply replace it.

—Don Mullikin, St. Petersburg, Fla.

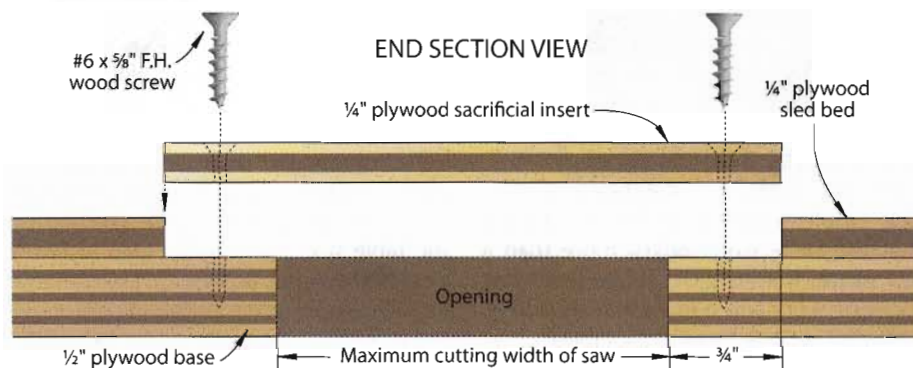
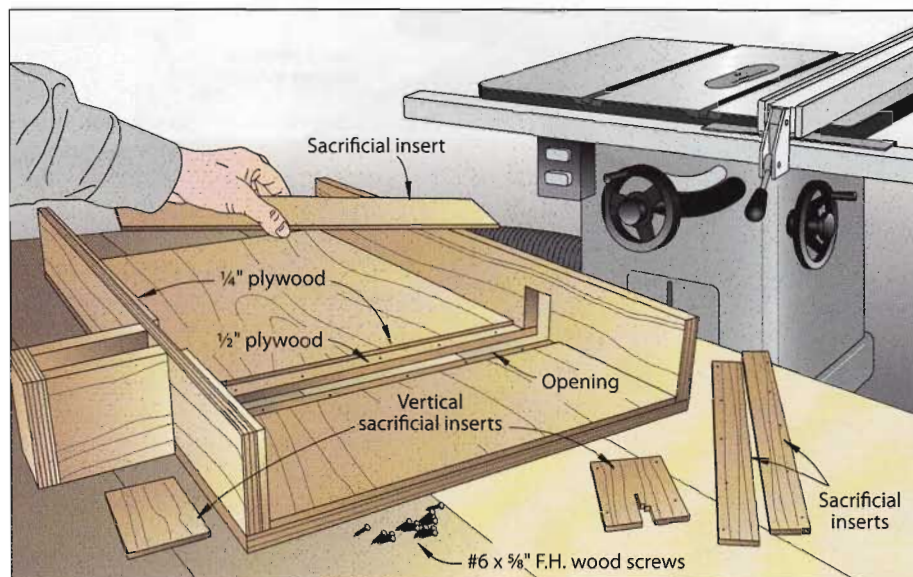

Microadjust your fence with a turnbuckle

Making superfine adjustments to my router-table fence was hit-or-miss until I came up with my own microadjustment system, shown at right. With this system, I simply clamp one end of the fence and make fine adjustments to the other end, fore or aft, with the turnbuckle.

To add a turnbuckle to your fence, use the hardware shown to add a pivot bolt to both the fence and the starting block. Use a turnbuckle with eyes large enough to fit snugly over the bolts. If the eyes are too large, fill them with epoxy, let it cure, and

then drill out the epoxy to fit the bolts. Use a washer on either side of the eye and tighten the assembly together.

The turnbuckle works best on the "push" stroke, so make all your final adjustments by driving the fence away from the starting block to take out any slack in the threads. To ensure that the fence doesn't move once you've got it perfect, clamp the turnbuckle end of the fence down. When not in use, you can leave the pivot bolt and eyes in place and simply remove the turnbuckle. Then store the fence and the starting block.

—Wayne Donovan, Kansas City, Mo.

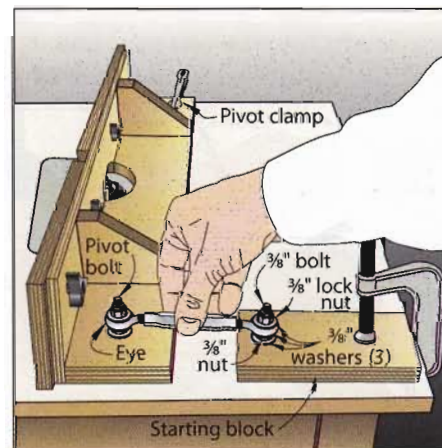

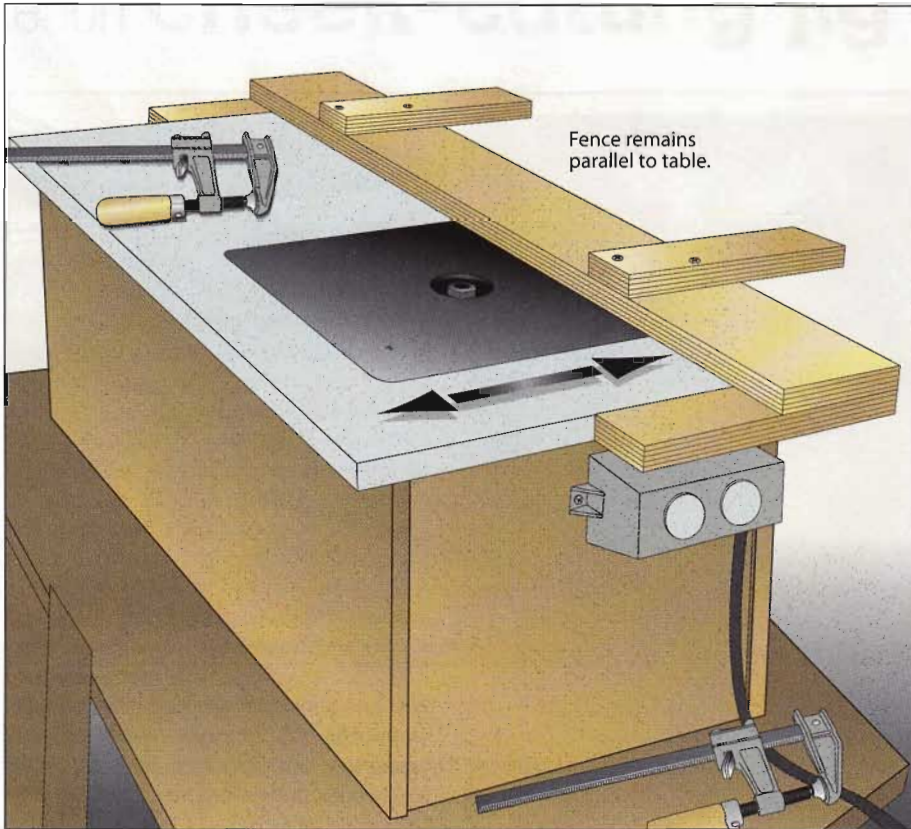

Dual-duty fence stretches router table's capacity

The problem with most router tables is that the fence won't adjust more than a few inches from the bit. While that's fine for edge work and a few other situations, it doesn't make full use of the table (for example, when fluting a wide workpiece).

To improve the situation, this two-way alternate fence works with both the length and width of your table. Depending on the table size, you may be able to firmly position the fence up to 20" away from the bit. The side arms automatically align the fence with the table, and a pair of bar clamps hold the fence solidly in place.

—Allan Rice, Winnipeg, Man.

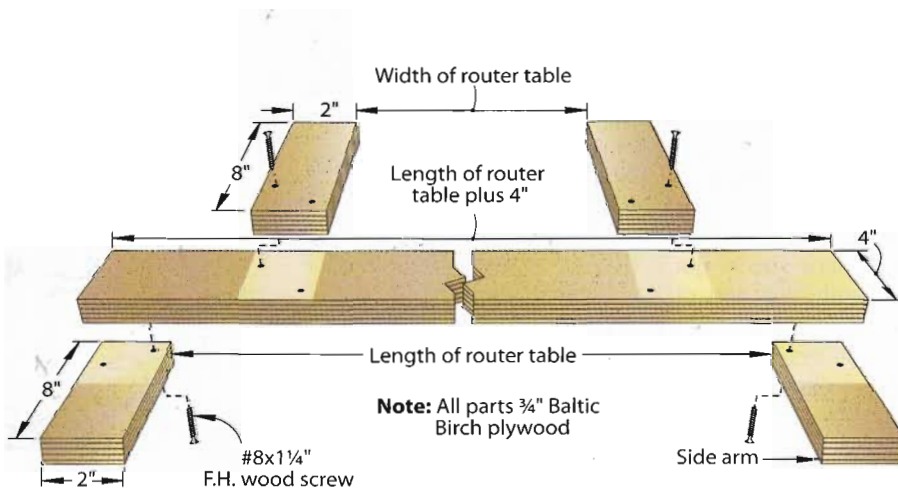

Wet/dry "vac rack" reins in wandering attachments

One of the most valuable tools in my shop is the wet/dry vacuum. However, like lost socks in a dryer, I had a serious problem keeping track of the various attachments. My solution was to build the wooden rack shown below to provide a stable home for the wandering attachments.

I cut the curved rack parts for my 1 1/4"-diameter vacuum accessories from scraps of 2x4; for 2 1/2" accessories, you may need to go with 2x6 stock. (The arc of your vac canister figures in here, too.) Your best bet is to first create a cardboard template that matches the contours of your canister. After assembly, secure the rack to the vac with stretch cords attached to the dowel rods.

—Charles Beach, Morganton, N.C.

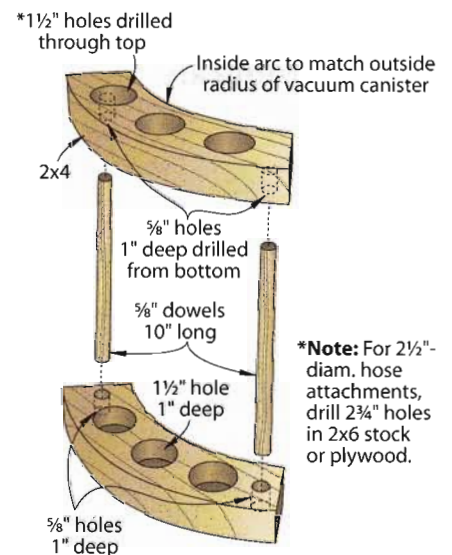

Suspended storage saves steps

Workbenches work best when they're in the middle of the shop so you can move around the project. The problem: Your tools are usually stored around the perimeter of the shop. The solution: the tool storage shelf, shown *below*. It not only

makes use of vacant overhead space—it also saves time and labor. Shaped like a stirrup and mounted to the ceiling joists, you can configure it to your needs to hold small hand tools, clamps, screwdrivers, and whatever else you want to keep handy.

—Bud Beck, Jr., Land O' Lakes, Fla.

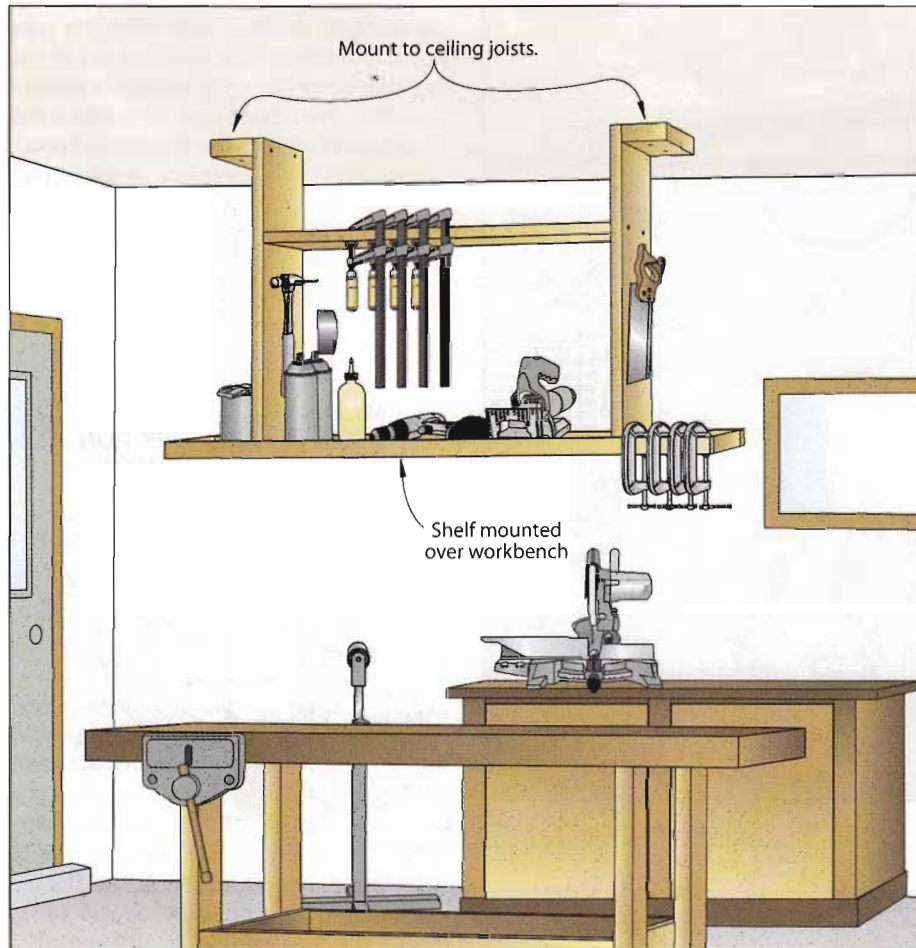

Bind bandsaw blades, then hang 'em high

I store bandsaw blades on the perforated-hardboard walls of my shop with steel binder clips (the kind you find at office-supply stores). The blades fit loosely in the clip, and the coils are kept together. I wrap electrical tape around each "jaw" inside and out to protect the blade teeth. To store them, I flip the handles around and hang the blade on a peg hook, as shown. $\frac{5}{8}$ " binder clips work for most blades, but for blades wider than $\frac{1}{2}$ ", use 1" clips.

—Jim Frye, Toledo, Ohio

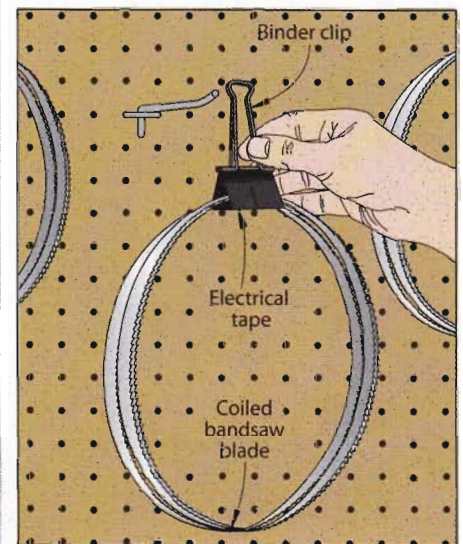

Coiling a bandsaw blade is easier than you think. Watch how it's done at woodmagazine.com/coilblade



No hang-ups with this shop-vacuum hoop skirt

I got tired of my shop vacuum catching on every machine in my shop as I pulled it across the floor. Frequently, the hose would add to the frustration by popping loose. So I took a lesson from amusement-park bumper cars and constructed a hoop from $\frac{1}{8}$ " tempered hardboard that goes around the casters. Now, the vac bounces off obstructions. Build the three-ply hoop, as shown, and screw or bolt it to the caster housings. Then take your newly remodeled vacuum out for a spin around the shop.

—Jack Hirrlinger, Davidsonville, Md.

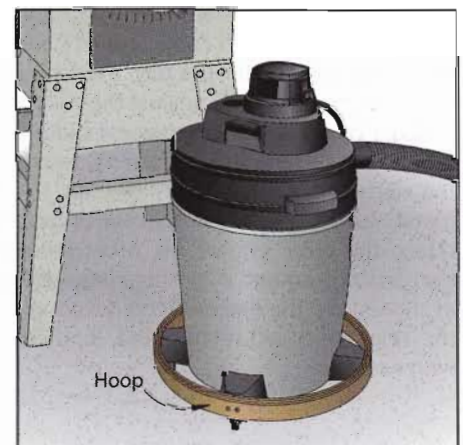
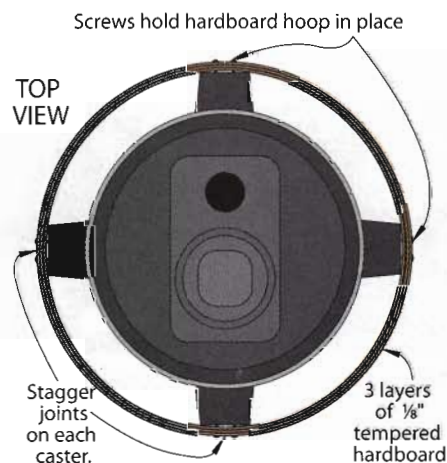

Telescoping light for perfect sight

While reclined in the dentist chair one morning, I watched as he manipulated that bright light to put it exactly where he wanted it. I thought: "That's what I need in my shop!" But after a little research, I

realized I'd need a second mortgage to buy such a fixture. So, instead, I came up with the telescoping light, shown *below*, for almost nothing. By sliding one 48"-long PVC pipe inside another, I can place the light directly over any point along a 10' workbench. (I recommend centering the

pipe over the bench to minimize shadows.) The inner pipe can be removed and slid into either end, and the cup hooks keep the cord secure and out of the way.

To safely cut the slot for the larger 1½" pipe, first center and mount the pipe to a 48" length of 2x4, screwing through the wood into the pipe. Set your tablesaw blade at the minimum height needed to cut through the pipe wall. With the pipe down and the 2x4 up, let the edge of the 2x4 ride along the fence to make a straight cut. With the second cut, complete a slot ¾" wide, as shown in the illustration *below*.

—Joe Dellaria, Woodbury, Minn.

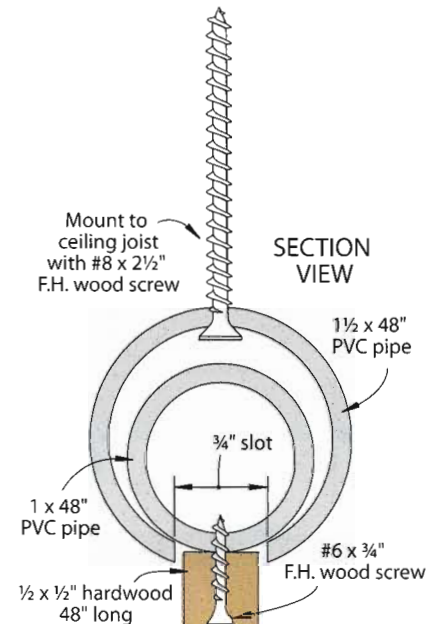
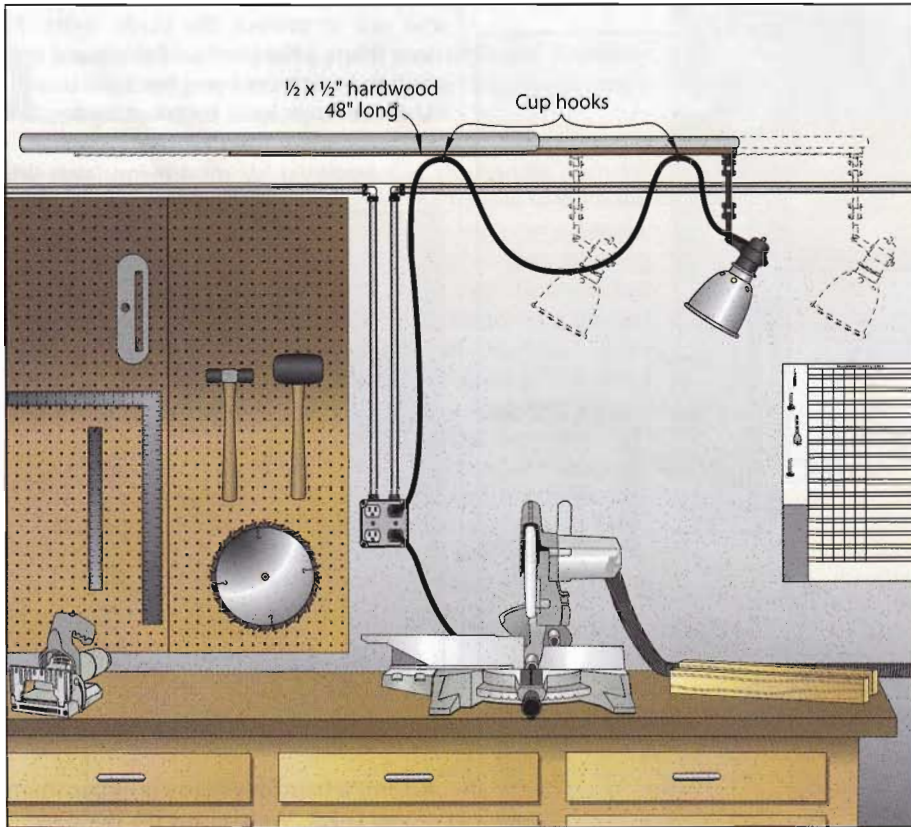

High-wire act for portable power tools

If you're tired of tripping over extension cords and accidentally kicking them loose from the outlet, run them overhead using the simple suspension cable shown here. When you're done for the day, the whole cord system slides back against the wall.

Begin by driving two screw eyes into a ceiling joist to hold the clothesline. Fasten the clothesline to one screw eye, slip the metal shower curtain rings over it, and attach the other end to the other screw eye. Space the rings along the clothesline as shown, slip the extension cord through the rings, and secure the cord to them with wire ties.

—Buck Nall, Alma, Ga.

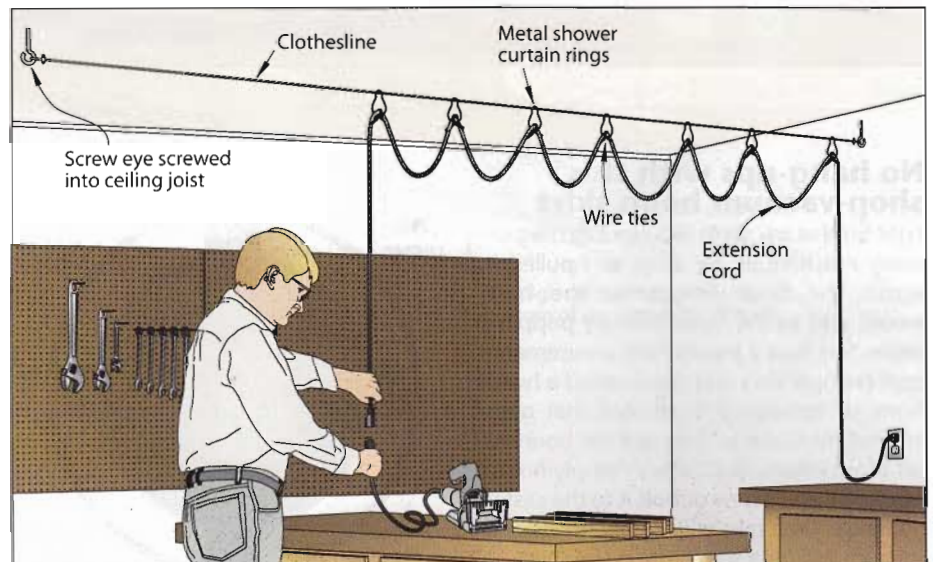



Turn Your Hobby into a New Career.

Learn furniture and cabinet making with at-home training.

With Penn Foster, you can learn the skills you need to turn a hobby into a profitable career in as little as six months. Learn the advanced woodworking techniques used in furniture and cabinet making. You can work for an established woodworking business or even start a business of your own.

Convenient. Penn Foster programs are designed to train adults for employment in the fastest-growing fields. You choose the time and place to complete your coursework, and you work at your own pace. All learning materials are sent directly to you.

Flexible. Study online, in print, or a combination of both. You decide which method best suits your learning style. You work independently, but not alone. Expert instructors and support staff — dedicated to helping you complete your coursework — are just a phone call or an email away. And you can interact with other Penn Foster students through our online community, including social networks, blogs, and discussion groups.

Accredited. Penn Foster Career School and Penn Foster College are nationally accredited by the Accrediting Commission of the Distance Education and Training Council (DETC). In addition, Penn Foster Career School is regionally accredited by the Middle States Commission on Secondary Schools for its high school and vocational-technical programs.



Affordable. Our low-cost tuition includes all materials as well as instructor support. We offer 0% APR financing and customized payment plans to best meet your individual needs.



Career Services. Current students and graduates are notified — through their personal message boards — of job openings submitted directly to Penn Foster by employers from around the country. Graduates of Penn Foster can take advantage of Penn Foster Career Services, which include access to job searches, tips on interviewing, and resume building with the help of a Certified Professional Resume Writer.

For fastest service, call toll free:

1-800-572-1685 ext. 6553

Call anytime, 24 hours a day, 7 days a week.

Or visit our website at

www.PennFoster.edu

Online enter ID# AWSS99T

Or mail the coupon today.



PENN FOSTER CAREER SCHOOL

925 Oak Street, Scranton, PA 18515-0700
www.PennFoster.edu

384 Furniture and Cabinet Maker

Building Trades

- 06 Electrician
- 104 Carpenter
- 15 Home Inspector
- 145 Home Remodeling and Repair
- 14 HVAC Technician
- 151 Plumber
- 102 Professional Landscaper

Mechanics

- 04 Auto Repair Technician
- 55 Diesel Mechanics
- 33 Motorcycle Repair Technician
- 89 Small Engine Repair

High School

- 07 Penn Foster High School
- 750 Penn Foster High School w/ Health Care Concentration

Business

- 70 Small Business Management

Technology

- 54 AutoCAD®
- 79 Electronics Technician PC Maintenance and Repair
- 27 Web Page Designer

Other Existing Programs

- 72 Appliance Repair
- 25 Gunsmith
- 58 Private Investigator
- 31 Professional Locksmithing

PENN FOSTER COLLEGE

Administrative Office
14900 N. Northlight Blvd.
Suite 111
Scottsdale, AZ 85260
www.PennFosterCollege.edu

Associate Degree Programs

- 61 Accounting
- 60 Business Management
- 418 Computer Information Systems
- 406 Criminal Justice
- 81 Finance
- 407 Graphic Design
- 412 Human Resources Management

- 66 Industrial Engineering Technology
- 80 Marketing
- 62 Mechanical Engineering Technology
- 408 PC Maintenance Technology
- 456 Retail Management

Please send me FREE information on the Career School or College program I have selected above. No obligation. Choose ONE only.

Name _____ Age _____

Street _____ Apt. # _____

City/State _____ Zip _____

Phone () _____ Email _____

Mail coupon to Student Service Center,* Dept. AWSS99T, 925 Oak Street, Scranton, PA 18515-0700.

*Under contract with Penn Foster College, AZ

1866F

Locate shelf-pin holes in a snap

When I build shelves I want them to be adjustable, and the most effective way to do that is with shelf pins. Getting perfectly repeatable results is challenging, though, unless you use an indexing system. To remove the risk and virtually eliminate measuring, I made this see-through indexing jig to create perfectly spaced $\frac{1}{4}$ " shelf-pin holes by the bushel.

The key to the jig is the spring-loaded pin, which snaps down into the previously drilled shelf-pin hole to ensure precise location. I made the pin by cutting the head off a $\frac{1}{4}$ "x3" bolt and then grinding a slight taper on the non-threaded end. Next, I drilled it and inserted a $\frac{1}{16}$ " roll pin in the rod to compress the spring. You can make the jig housing as shown with almost

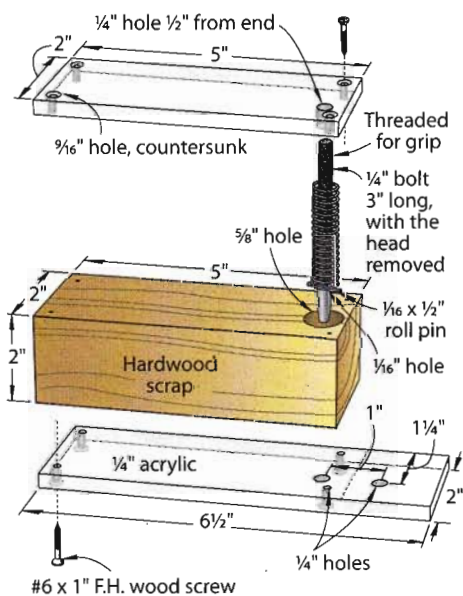

any material, but I used $\frac{1}{4}$ " acrylic for the top and bottom, as shown. It provides a slick surface and allows me to see the hole I previously drilled.

To use the jig (as shown, it spaces holes 1" apart and $\frac{1}{4}$ " on center from the edge of the workpiece), set your drill-press fence $\frac{1}{4}$ " from the bit center and drill the first hole. Now, place the jig over the workpiece so that the pin snaps into the hole. Move the workpiece and jig together along the fence until the drill bit fits perfectly into the bit-index hole in the base, and then clamp the jig to the fence. Once attached to the fence, it will now "float" over the workpiece, so you can drill a hole, lift the pin, slide the workpiece along the fence until the pin snaps down into that hole, drill, and repeat.

—Vell Holcombe, Milton, Penn.

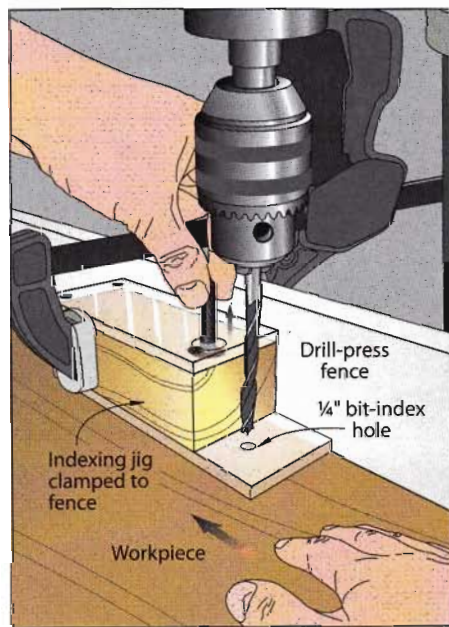

Mark screw-hole centers for faster assembly

For casework fastened together with lots of screws, you want all holes evenly spaced on all sides of the case, especially if the screws will be covered with visible caps or plugs. To ease the task, make the marking guide shown below. Measure carefully and mark hole centers on the sides with an awl, as shown. When it comes time to drill pilot holes for your screws, hold the guide in place and drill right through it. Flip it over to use on the other side of the case, and drill through the holes you just made.

—The Editors of WOOD® magazine

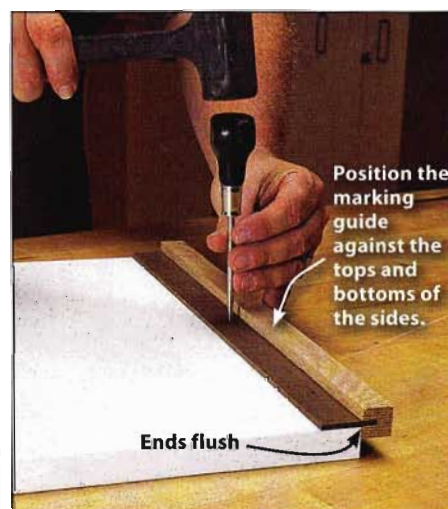

Ensure matching drawer-pull locations

For drawers with two pulls, here's a fast way to ensure matching pull locations at opposite ends of the drawer face. Cut a piece of scrap for a template. (We used $\frac{1}{4}$ " hardboard; our piece for the drawer shown measures 6" square.) Then, drill a hole for the pull screw (or two holes for a handle-type pull) through the template at the desired location. Now, hold the template against the drawer face, as shown at right, and drill the first pull hole through the face and drawer box. Flip the template and drill the other pull hole.

—The Editors of WOOD magazine

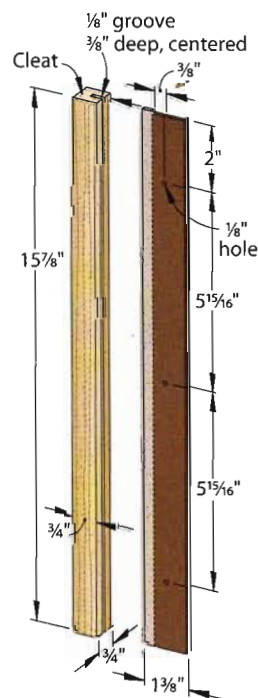
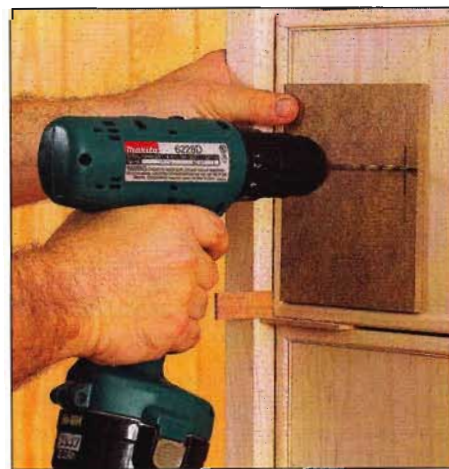

A mini bar clamp with a delicate touch

For small or fragile glue-ups, such as doll-house furniture or models, spring-type clothespins provide the right amount of clamping pressure. Problem is, the jaw openings are often too small. To solve this problem, I altered a wooden clothespin to make a mini adjustable bar clamp.

To make one for yourself (I make at least six at a time), begin by cutting the clothespin jaws, where shown *below*. Next, attach

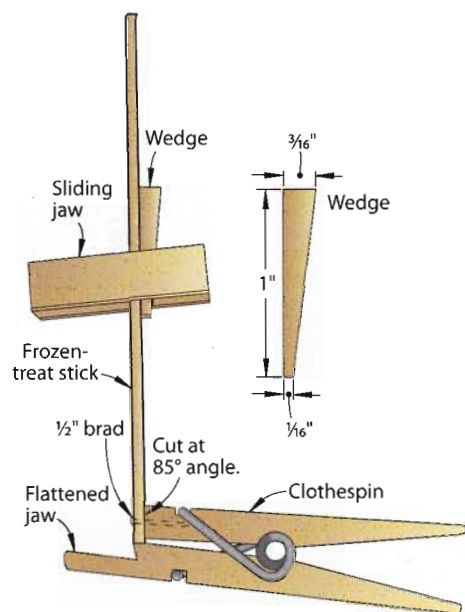

a frozen-treat stick to the clothespin's upper jaw with a brad and some glue. Be sure to drill the brad-nail hole first to avoid splitting the thin wood. Finally, glue the sliding jaw parts together, as shown in the Sliding-Jaw Detail, *below*.

To use the clamp, simply slide the jaw to the desired opening and secure it to the frozen-treat stick with the wedge. As shown, the mini bar clamp can hold assemblies up to 4" thick.

—Bob New, Cockeysville, Md.

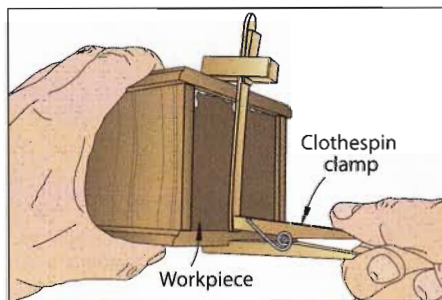
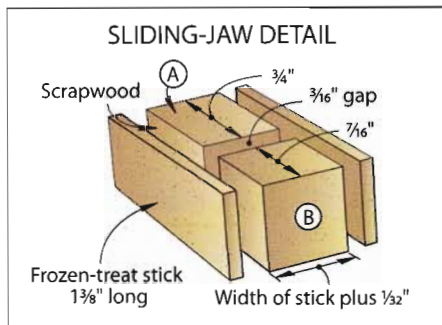

"Cheat sheet" meets cookie sheet

I've used the *WOOD*® magazine "Drill-Press Speed Chart" for years, trying to keep it taped up on the perforated hard-board mounted on the wall behind my drill press. Unfortunately, the tape kept letting loose and the chart was always falling off. To prevent that, I grabbed an old cookie sheet from the kitchen, taped the chart to the metal, and hung it on an available hook.

Then, taking it a step further, I made an additional chart showing the full range of my drill press' speed settings, added that to the sheet, and then stuck on a magnet to correspond to the drill's current speed.

—Larry Cramer, Troy, Mich.

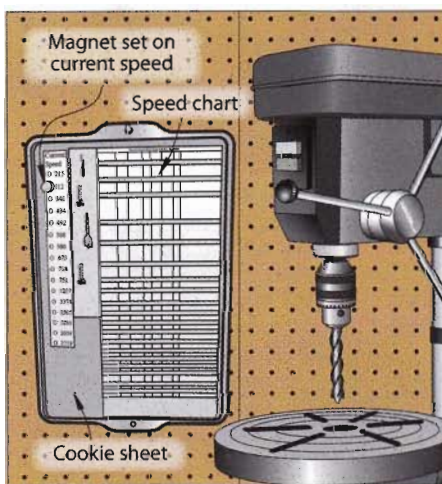

Find the free Drill-Press Speed Chart at:
woodmagazine.com/charts



Positive stop for disc sander table

I make small toy parts that require a great deal of accurate sanding. For that accuracy, I use a 1"-belt/6"-disc sander that, unfortunately, uses small, hard-to-tighten wing nuts to secure the sanding table. If a nut works loose, which happens frequently, the table slips down. To fix this, I created a carriage-bolt support post for the table, as shown *below*, that keeps the table perpendicular to the disc.

To make the support post, cut a 1"-wide strip of scrapwood about as long as the sanding table to house the post. Install a 5/16" T-nut in the bottom of the strip, as shown, and add the bolt, wing nut, and washer. Finally, glue and screw the strip to the sander's base.

After locking the table square to the disc, turn the carriage bolt until it rests on the underside of the table. Then, lock it in place by tightening the wing nut against the washer and strip.

—John Shaw, Falmouth, Mich.

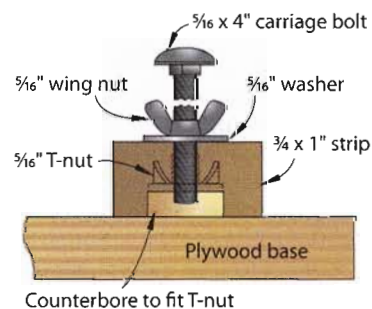
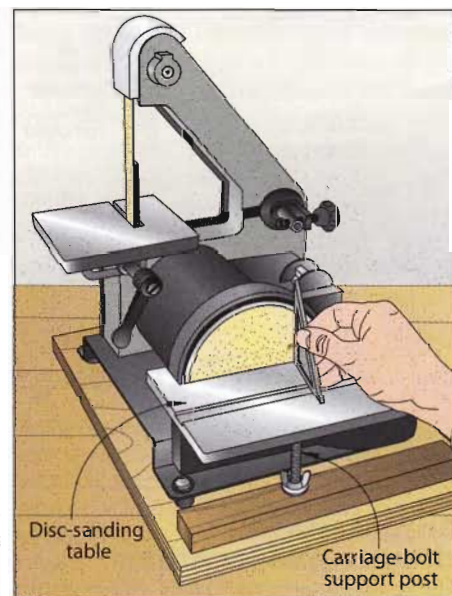

Drill-bit speed reminders

Every drill bit has its optimal speed where it cuts quickly without burning. You can keep a drill-press speed chart handy, but here's a no-fuss way to get the right speed for bit sets that come in cases. Write the recommended speed next to the bit inside the case, as shown at *right*. Here's the method I use: On the top line, I jot down the softwood speed; below that, the hardwood speed. To save space, I drop the last two zeros from the number. For instance, 600 rpm would be expressed simply as 6. A 23 indicates 2,300 rpm.

—John Anderson, Long Island, Va.

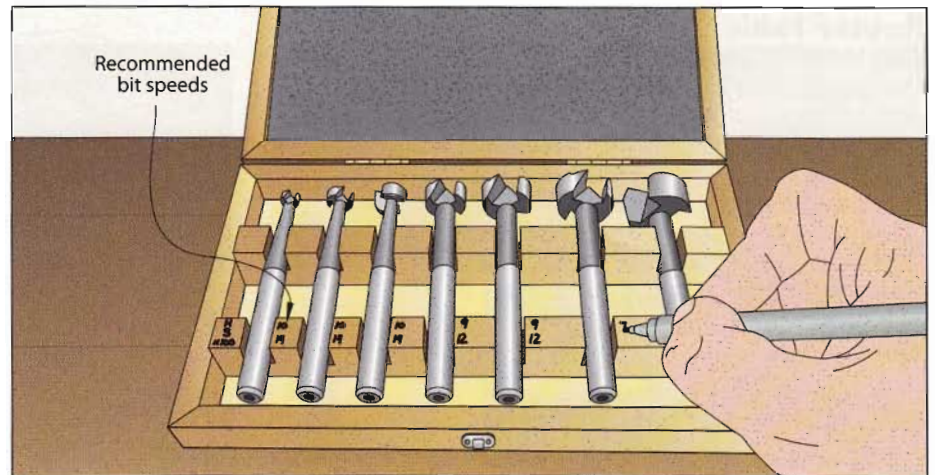

Self-cleaning lathe-tool storage

I like to have my lathe tools close at hand, so I found a way to mount 12"-wide wire closet shelving to my lathe stand. The plastic-coated stuff is available at every home center, and when installed upside down, it keeps lathe chisels from rolling off the shelf.

After finding where the front-to-rear splay of the legs of my stand equals 11½"—the distance between the outer bars of the shelving—I marked that height on all four legs. Then, I cut the shelving to

the length between those marks, leaving an extra 1" or so of edge bar and shelf-base bar on each end. On most lathes, you'll probably have to loosen at least one leg on the stand to slip the shelving into place. After that, gravity and the splayed legs keep the shelf in place.

On lathe stands without splayed legs, you could drill holes in the stand just underneath where the shelf will rest, and then insert ¾x1" hexhead bolts, nuts, and lock washers. The bolt heads will support the shelf ends.

—Bob Zajicek, Marietta, Ga.

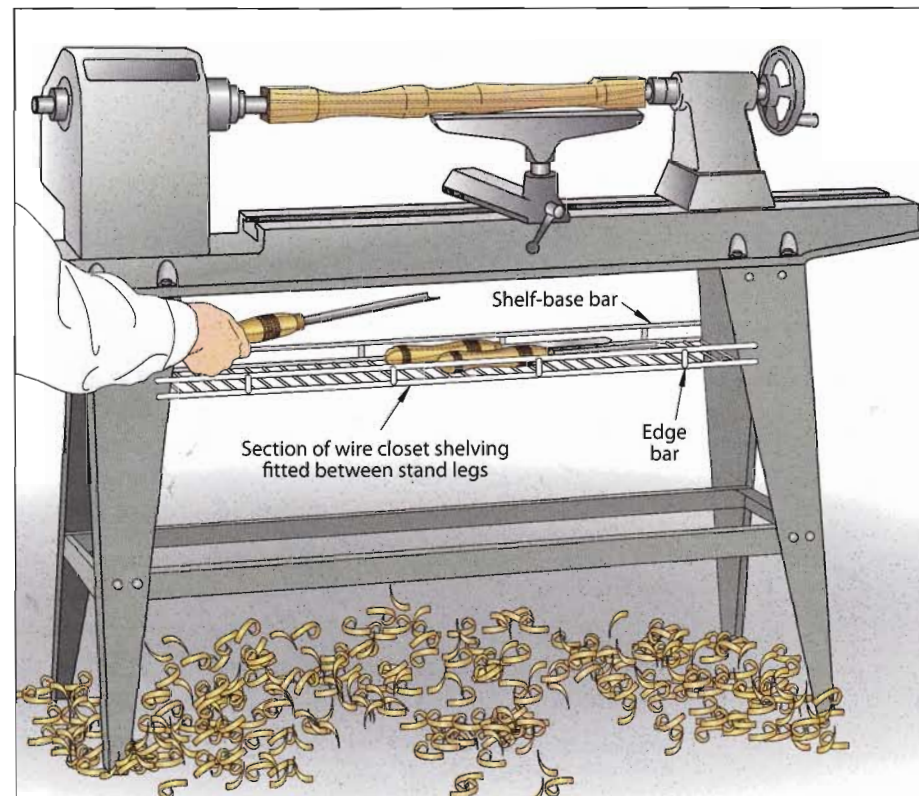

Dust-collection air intake

Many woodworkers hook up a 4" dust-collection hose to a mostly enclosed tool cabinet such as one below a router table or downdraft table. They figure that by pulling 4" worth of air through a 1" bit opening, the dust and chips ought to go screaming through the box and into that dust hose. In truth, they're choking off the airflow, killing the dust-collection efficiency.

To remedy this, simply install a dust-collection blast gate on the cabinet, located opposite the hose for outgoing dust, as shown *below*. By opening this blast gate, you create a "river" of air flowing through the cabinet. Debris is pulled into the river and carried downstream and right into the collector. If you lose too much suction with the gate wide open, gradually close it until you achieve maximum dust collection.

—Jim Kahl, Edgewood, Md.

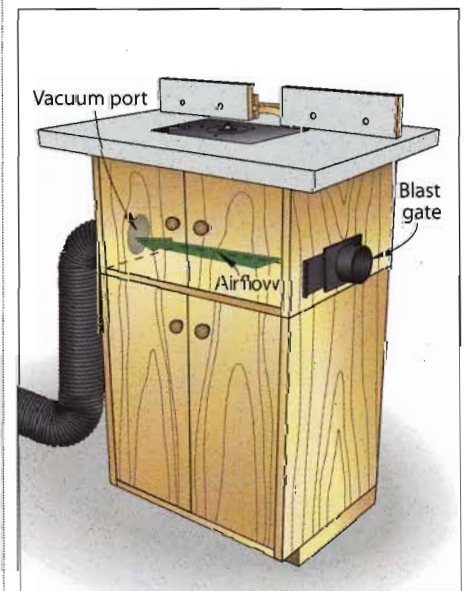

Router-table dust-collection box

The dust-collection box under my router table connects to the in-floor shop dust-collection system. As shown at right, the bottom slopes down to the vacuum port so dust and chips are easily sucked out of the bottom of the bay.

—Randy Zimmerman, Indianola, Iowa

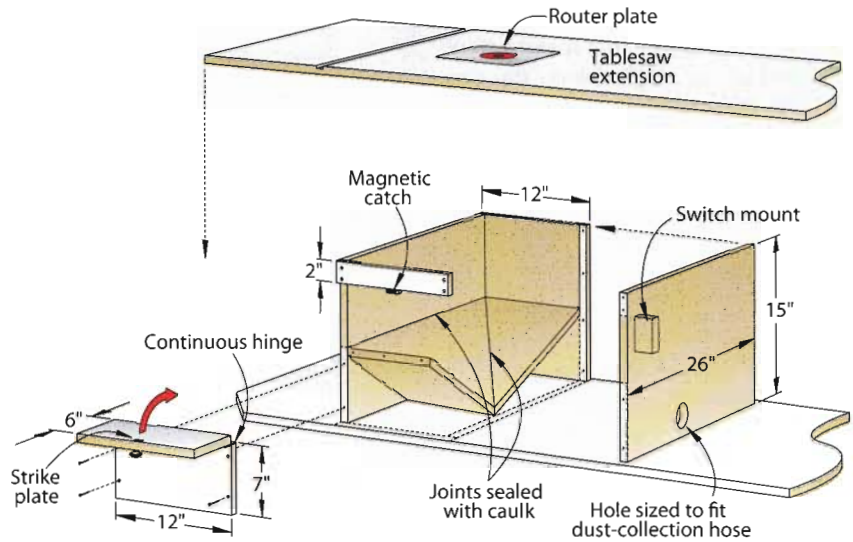

Get a grip on corner blocks with a clamp block

When mounting corner blocks to reinforce a frame or case, it helps to use a clamp block on the outside to provide a flat surface for secure clamping and to prevent damage to parts. For the table shown below, we made a notched clamp block with a notch from 3/4"-thick scrap, then glued and clamped the corner block in place. Then we used a combination drill and counter-sink bit to drill the mounting holes.

—The Editors of WOOD® magazine

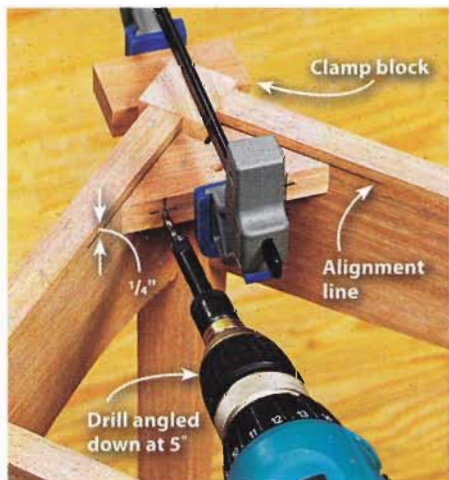
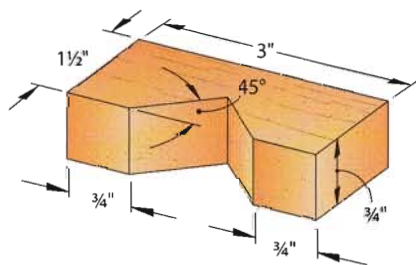

Exact-size sandpaper cutter

I used five pieces of stock in various widths and thicknesses glued edge to edge, with a shallow rabbet to hold a hacksaw blade, to create a handy helper for cutting sandpaper to the correct sizes for my portable sanders and sanding blocks. Epoxy secures the blade. To size the paper, I just butt the sandpaper up to the appropriate block and tear sharply downward. *Note: You may have to adjust width of stock to accommodate your particular sander.*

—Lynn "Jumbo" Lawrenz, Algoma, Wis.

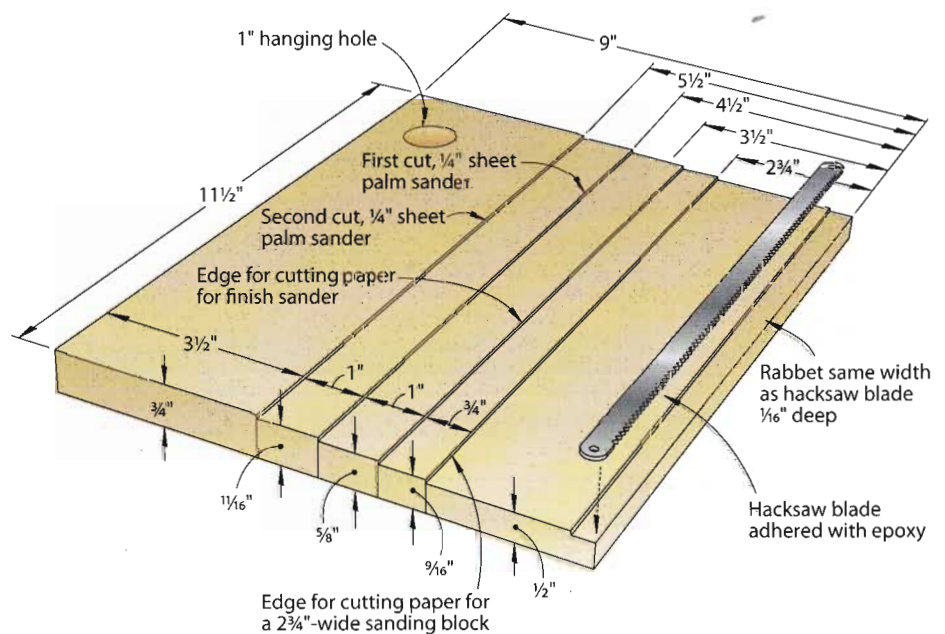

Flush-trim guide for hardwood edging

Ever tried to trim edging flush with an end or edge of a plywood panel and accidentally cut into the panel? With the jig shown *below*, you'll quickly trim all of your edging perfectly flush, eliminating alignment guesswork and miscuts.

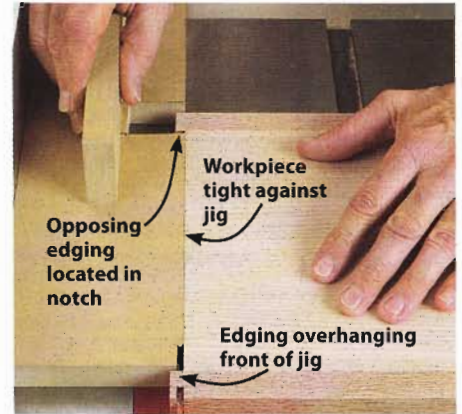
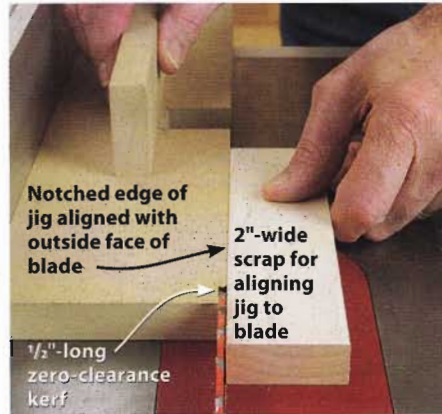
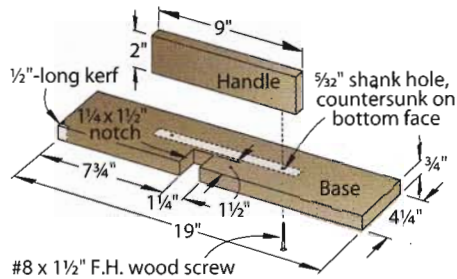

Step 1: Make the jig from $\frac{3}{4}$ "-thick scrap, cutting the $1\frac{1}{4} \times 1\frac{1}{2}$ " notch in the base, where dimensioned. (Cut the $\frac{1}{2}$ "-long kerf in the base in the next step.) Depending on the project, you may need to change the location of the notch and length of the jig, according to the size of the panel you're edging.

Step 2: With the saw off, position your tablesaw fence to align the notched edge of the jig with the outside face of the blade. To verify precise alignment, hold a 2"-wide piece of $\frac{3}{4}$ " scrap against the jig, extending the front end by about 1". Now, cut a $\frac{1}{2}$ "-long kerf in the jig, as shown. Examine the edge of the 2"-wide scrap and make sure you don't see any saw marks. If you do, adjust the fence and test again.

Step 3: Place the workpiece tight against the jig with edging pieces overhanging the front end and extending into the notch. (For panels more than 19" in width or length, let the edging overhang both ends of the jig.) Flush-trim the front edging, stopping when the blade enters the clearance kerf. (To maintain proper workpiece support, don't cut deeper into the kerf.) Now, flip the panel and trim the opposite edging.

—The Editors of WOOD® magazine

Rooftop sheet-goods rack

I couldn't load 4x8 sheet goods inside my SUV, and those sheets just didn't sit securely on the curved cross rails of the factory-supplied roof rack. To haul whole sheets home safely and easily, I built the carrier shown at *right*.

The 2x4 structure fits over the roof rack, which keeps it from sliding and protects the vehicle paint. The 1x6 front stop prevents the load from sliding forward when I brake. (I don't load panels any higher than the front stop.) The rear stop flips down for loading, and up before driving so panels won't slide off the back.

Make sure the weight of the carrier and the material on it doesn't exceed the weight capacity of your vehicle's roof carrier (shown in the owner's manual). After loading, run a ratcheting tie-down strap through the front doors (*not* the windows) and over the load. Run another strap under the factory roof-rack rails and over the load at the back. Then, drive home on city streets to avoid high speeds.

—Kevin McLaughlin, Helena, Ala.

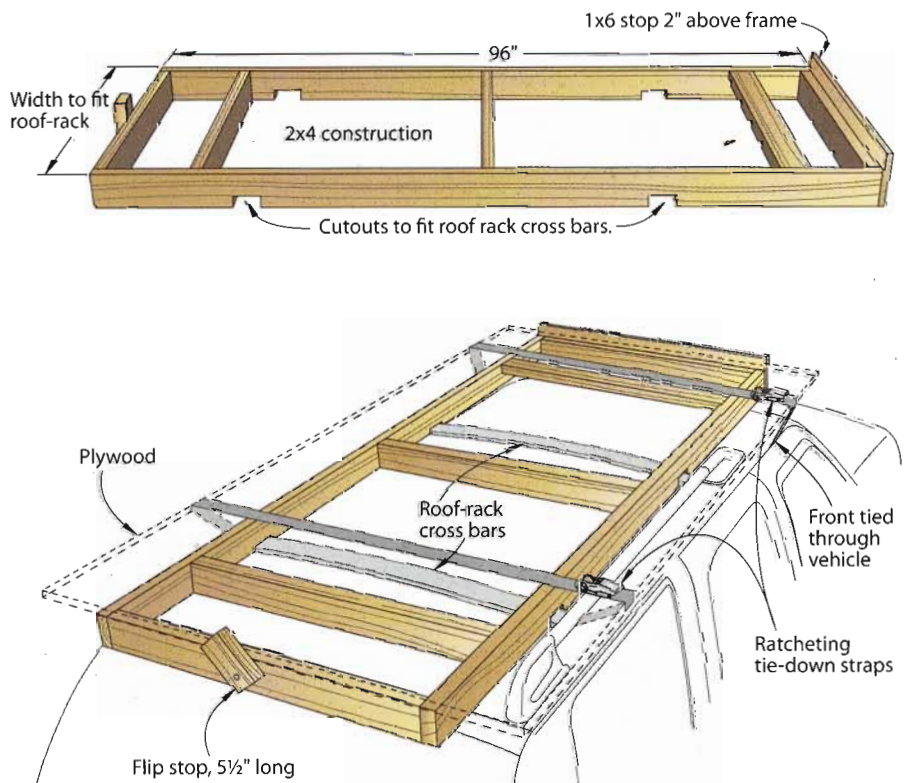

Roller boards for smooth outfeed

These roller boards allow sawn wood to glide onto my saw's outfeed table. Rare-earth magnets inserted into holes on my workbench keep the roller frames in place. I built the boards out of oak, but you can use any wood. The only critical dimension is the thickness of the roller assembly. The height of the bearings must equal the height of the saw, so when the piece comes off the saw table, it stays level and doesn't fall or get elevated.

—Scott Beresford, Pittsburgh, Pa.

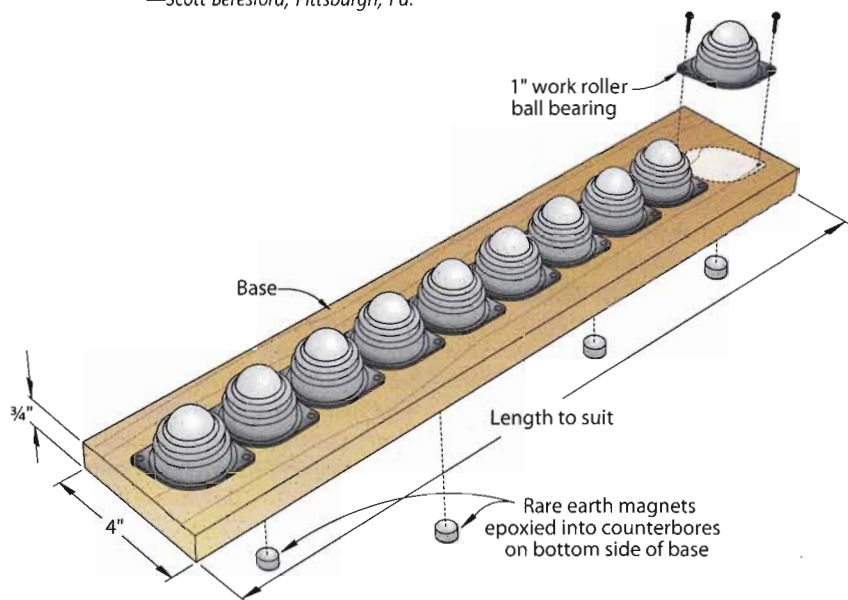

Nailing gauge for perfect placement

When driving screws or nails into a joint, I would either eyeball the row of fasteners (which sometimes sent them splitting out the back of the joint) or, if I was in a perfectionist mood, measure and mark a line (one I would later have to sand off). But recently, I stumbled onto a third option: this

simple edge-nailing gauge, inspired by the shape of a flat pry bar. The gauge not only helps me place the fastener dead center every time, it also helps steady the fastener, limits hammer dings, and makes a tidy row of the exposed heads. The gauge works so well, I made several more to use for different stock thicknesses. 🌲

—R. B. Himes, Vienna, Ohio

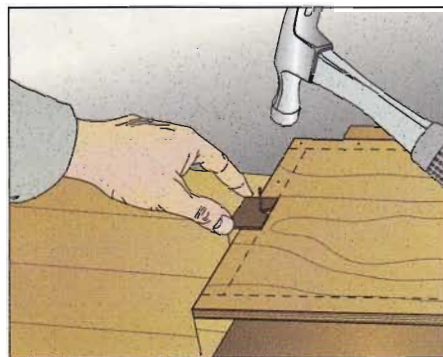
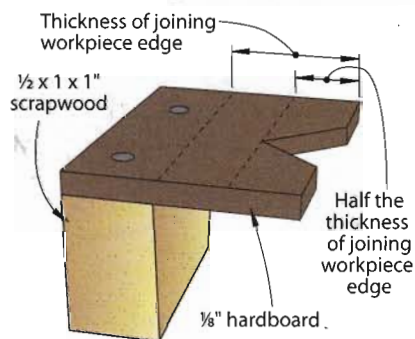

Lift-assist help for tilt-top router tables

My router-table top attaches to its cabinet with a hinge, making it very convenient when I want to change or adjust the height of a bit. Unfortunately, the top is heavy and occasionally slams down unexpectedly. Not only are these sudden falls hard on the router, but fingers that happen to be in the way don't fare very well either. Prevent these sudden freefalls by installing a standard pneumatic storm-door closer that acts as a lift-assist device.

To install the closer, attach its brackets and pull out the rod to the maximum distance. (Use the rod's hold-open clip to keep it extended.) Then, position the closer brackets far enough forward so they can bear the weight of the top, and high enough that the top can open to the desired distance. Screw the brackets to the cabinet and top, and set the pressure-adjustment screw on the back of the piston housing so the top lowers at whatever speed you want.

With the closer in place, you can use the hold-open clip to keep the top up while you adjust the router. Most hardware stores and home centers carry door closers as replacement parts, or you may be able to salvage one when you or a neighbor replaces a storm door.

—Yaniv Matza, Tamarac, Fla.

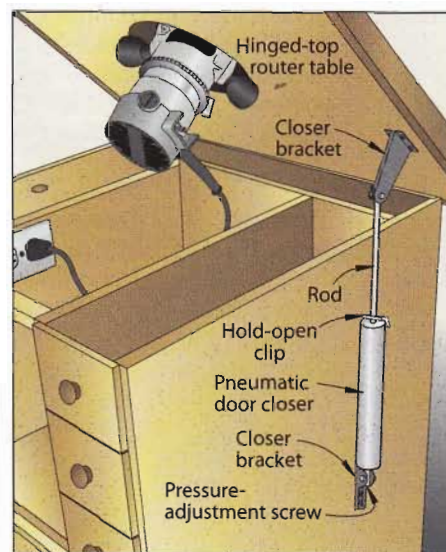

WOODCRAFT®

For A Free Catalog Or To Find Your Local Woodcraft Store, Visit woodcraft.com Or Call 800-225-1153.

Introducing *Woodcraft Magazine's* Classic® Project Plans. Here's your chance to own and use our new 22" x 34" shop-friendly project plans featuring *Woodcraft Magazine's* best-ever products. Each plan includes step-by-step instructions with detailed photographs, exploded-view illustrations, full-sized patterns, a cut list, cutting diagram, and a Convenience-Plus Buying Guide so you know exactly what supplies are required to complete the project. Whether you are a beginner or an accomplished woodworker, the Woodcraft Classic Project Plans series has a plan for you!

Please visit <http://www.woodcraftmagazine.com/plans/projectplans.aspx> for a full listing of available small, medium, and large size project plans.

Classic® PROJECT PLANS



**Flat Panel TV
Entertainment Center**
148854

**Intarsia Presidential
Dollar Plaque**
148857

Heart Shaped Music Box
148860

Heirloom Quilt Stand
148855

**Country Classic
Step-Back Cupboard**
148858

Garden Arbor and Gate
148861

**Mission Coffee Tables
and End Tables**
148856

**Arts and Crafts
Pendulum Clock**
148859

**Rod Reel and
Tackle Stand**
148862

Adirondack Chair
149235

Cross Brace Chair
148863



09W10P

QUALITY WOODWORKING TOOLS • SUPPLIES • ADVICE®

©2009 Sears Brands, LLC

THE POWER
AND VERSATILITY
OF SIX TOOLS.
PACKED INTO ONE.

INTRODUCING THE 12-VOLT CRAFTSMAN CORDLESS MULTI-TOOL

With the ability to sand, scrape, saw, and smooth, this portable tool puts the power to complete any job right in the palm of your hand. With innovation and better value, trust that Craftsman has the tool to get the job done right. Find it at craftsman.com

Sears THE HEADQUARTERS OF CRAFTSMAN

CRAFTSMAN®
TRUST. IN YOUR HANDS.