

TOOL TEST: Plunge Routers

WORKBENCH™

WOODWORKING TO IMPROVE YOUR HOME

Step-by-step to . . .

Revive Your Deck!

PLUS:

- Build a Classic Heirloom Bed
- Organize Your CDs with a Simple Shelf

Contents



22

DECK RENOVATION

18

Revive Your Tired Deck

With a bit of elbow grease and the right strippers and cleaners, you can make your old deck look brand new in no time.

21

Product Selection

Find out what's safe and best to use when it comes to cleaning and protecting your deck.

22

Deck Rail Redo

Complete your deck renovation by adding decorative railing you can make in the shop, plus built-in lighting for nighttime enjoyment.



18



21



21



30

PLUNGE ROUTER REVIEW

30

In-Depth Tool Testing

Midsized plunge routers offer the perfect blend of power, versatility and control. We tested six popular models to see who rules the middle ground.

36

Mastering Mortises

No mortising machine? No problem. Forget about the drill press — and rout perfect mortises every time using your midsized plunge router.

38

Heirloom Bed

Rest assured, the solid construction and simple design of this queen-sized cherry bed will make it a family classic.

50

CD Storage Shelf

Discover the "secret" to building this great weekend project.

54

Bright Ideas

See how design professionals can solve your everyday lighting problems.

58

Under-bed Storage

Make good use of wasted space with this drawer-on-wheels.



58



54



50

DEPARTMENTS

5

Questions & Answers

8

Tips & Techniques

12

Workbench Interactive.com



8

15

In The Shop

59

Sources & Resources

61

Craftsmanship

61





EDITOR'S NOTES

While I'm writing this, I'm looking out at snow piled high on the deck featured on this issue's cover. It sure doesn't look as warm and inviting as when the cover photo was shot last fall.

Depending on where you live, it may not be snowing, though it's probably still a bit cold outside to get excited about working outdoors. Now, however, is the perfect time to start planning warm-weather projects.

If you're thinking about rebuilding or renovating a deck, now's the time to take some measurements and figure out how you can apply the ideas in this issue to *your* deck. Then, you may want to take a trip to the local home center to price materials.

About the time the first lilac buds are as big as a squirrel's ear, you'll be ready to get to work.

CLEAN, REPAIR, AND REBUILD

The deck article on pages 18-29 is actually two stories. The first one covers cleaning, repairing, and stain-

ing an existing deck. In the second one, we show you how to replace plain straight rails and balusters with fancy ones you can make in your own shop.

Though the second story makes the whole project more appealing, it was the cleaning and restaining steps that seemed to draw the most questions from the neighbors.

Is it okay to use laundry bleach? Are special deck cleaners worth the cost? Should you stain, or just let the deck "go gray" and not have to restain every couple years? And, if you do stain, is it better to use a transparent, semi-transparent, or solid-color stain?

You've probably got lots of questions, too. But it's still early — there's plenty of time to do your research. I hope this issue of *Workbench* helps. And keep your eye on those lilac buds.

HOW TO REACH US

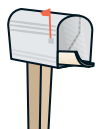

Editorial Questions:
Workbench Magazine
 2200 Grand Ave.
 Des Moines, IA 50312
 e-mail: editor@workbenchmag.com

Subscriber Services:
Workbench Customer Service
 P.O. Box 842
 Des Moines, IA 50304-9961
 Phone: (800) 311-3991
 Fax: (515) 283-0447



On The Internet:
www.WorkbenchMagazine.com
Free Weekly Woodworking Tip:
www.WoodworkingTips.com

Online: www.WorkbenchMagazine.com

- Access your account
- Check on or make a subscription payment
- Change your mailing or e-mail address
- Tell us if you've missed an issue
- Renew your subscription

WORKBENCH™

VOLUME 57

NUMBER 2

EDITOR Doug Hicks

ASSOCIATE EDITOR Kerry Gibson

ASSISTANT EDITORS Bill Link

Kevin Shoesmith

Joel Hess

ART DIRECTOR Robert L. Foss

SR. GRAPHIC DESIGNER Mike Mittermeier

SR. ILLUSTRATOR Susan R. Jessen

ILLUSTRATOR Mark S. Graves

CREATIVE DIRECTOR Ted Kralicek

SENIOR PHOTOGRAPHER Crayola England

PROJECT COORDINATOR Kent Welsh

PROJECT DEVELOPER Ken Munkel

PROJECT DESIGNER Chris Fitch

SHOP MANAGER Steve Curtis

SHOP CRAFTSMAN Steve Johnson

ELEC. PUB. DIRECTOR Douglas M. Lidster

PRE-PRESS IMAGE SPECS. Troy Clark

Minnie Johnson

PRESIDENT & PUBLISHER Donald B. Peschke

ADVERTISING SALES MANAGERS

Mary K. Day (515) 282-7000 ext. 2200

George A. Clark (515) 282-7000 ext. 2201

DIRECT RESPONSE ADVERTISING

SALES MANAGER

Lisa Wagner (407) 645-5165

The Ad Rep Firm

ADVERTISING COORDINATOR

Kelsey Hare (515) 282-7000 ext. 2135

PUBLISHING CONSULTANT

Peter H. Miller (202) 362-9367



MAGAZINE PUBLISHERS OF AMERICA



WORKBENCH (ISSN 0043-8057) is published bimonthly (Jan., Mar., May, July, Sept., Nov.) by August Home Publishing Company, 2200 Grand Ave., Des Moines, IA 50312.

Workbench is a registered trademark of August Home Publishing. Copyright ©2001 August Home Publishing Company.

All rights reserved.

Subscription rates: Single copy, \$3.95. One-year subscription (6 issues), \$15.94; two-year sub., \$27.95; three-year sub., \$39.95. Canadian/Int'l., add \$10.00 per year. Periodicals postage paid at Des Moines, Iowa, and at additional offices.

"USPS/Perry-Judd's Heartland Division automatable poly."

Postmaster: Send address changes to *Workbench*, PO Box 37272, Boone, IA 50037-0272.

Printed in U.S.A.



President/Publisher:
 Donald B. Peschke

Corporate Services: *Director of Finance:* Mary R. Scheve
Controller: Robin Hutchinson • *Senior Accountant:* Laura Thomas •
Accounts Payable: Mary Schultz • *Accounts Receivable:* Margo Petrus
Production Director: George Chmielarz • *Production Coordinator:*
 Noelle M. Carroll • *Network Administrator:* Kris Schwanebeck • *New Media Manager:* Gordon Gaippe • *Web Site Art Director:* Gene Pedersen • *E-Commerce Analyst:* Carol Pelz-Schoeppler • *Web Site Content Managers:* Terry Walker, David Briggs • *Professional Development Dir.:* Michal Sigel • *Human Resources Asst.:* Kirsten Koelke • *Facilities Manager:* Julia Fish • *Receptionist:* Jeanne Johnson
Mail/Delivery Clerk: Lou Webber • *Circulation:* *Subscriber Services Director:* Sandy Baum • *Manager, New Business:* Wayne Klingbeil • *Promotion Manager:* Rick Junkins • *Renewal Manager:* Paige Rogers • *Billing & Collections Manager:* Rebecca Cunningham
Marketing Analyst: Kris Schlemmer • *Assoc. Marketing Analyst:* Paula M. DeMatteis • *Creative Resources:* *Executive Editor:* Douglas L. Hicks • *Associate Editor:* Craig Ruesegger • *Art Director:* Douglas A. Flint • *Senior Graphic Designers:* Chris Glowacki, Mark Hayes, Robin Dowdell • *Graphic Designers:* Vu Nguyen, April Walker Janning • **Products Group:** *Operations Director:* Bob Baker • *Customer Service Manager:* Jennie Enos • *Warehouse Supervisor:* Nancy Johnson • *Buyer:* Linda Jones • *Administrative Assistant:* Nancy Downey • *Technical Service Representative:* John Audette • *Customer Service Representatives:* Anna Cox, Tammy Truckenbrod, Deborah Rich, April Revell, Valerie Jo Riley, Linda Stepp • *Warehouse Staff:* Sylvia Carey, Sheryl Knox, Albert Voigt • **Woodsmith Store:** *Manager:* Dave Larson • *Sales Staff:* Wendell Stone, Jim Barnett, Kathy Smith, Larry Morrison, Harold Cashman, Tim Thelen, Mark Johnson • *Office Mgr.:* Vicki Edwards

Questions & Answers

Diggin' Deep to Avoid "Frost Heave"

Q My neighbor who recently moved here from Florida is building a deck that will be attached to his house. The deck footings are currently only about 24" deep. I warned him that wasn't nearly deep enough, but he thinks I'm pulling his leg. Please help me. There's an unfinished deck waiting for your reply.

George Gladbrooke
St. Paul, MN

A Down in "Gatorland," your neighbor probably wouldn't have any problems setting his footings a couple of feet deep. That would also work for a floating deck that isn't attached to any structure. But in colder climates, with a deck that's attached to the house, those footings better be buried deep enough to escape the effects of "frost heave."

The drawing at left and the map below show some typical frost depths for different climate zones. It's always a good idea to ask about the frost line in your area when applying for a building permit.

Coming from the Sunshine State, your neighbor might not know about frost heave. As temperatures drop below 32° F, moisture in the ground freezes from the top down. At the same time, it expands and compresses the surrounding soil. This thrusts or heaves the soil — and anything resting on it — upward. This includes the footings, support beams, and ultimately the deck itself.

Next spring, when the ground thaws and everything starts settling, there's no guarantee the footings will settle evenly back to their original position. After a couple years of this freeze-thaw cycle, your neighbor might end up with a deck that's badly sloped, wavy, or just plain unsafe.

To ensure his deck remains flat, level, and solid for many years, tell your neighbor to set the footings below the frost line. In the Land of 10,000 "Frozen" Lakes, that's usually somewhere between 48" to 60". Soil type and the weight of a deck also affect the depth and size of footings required.

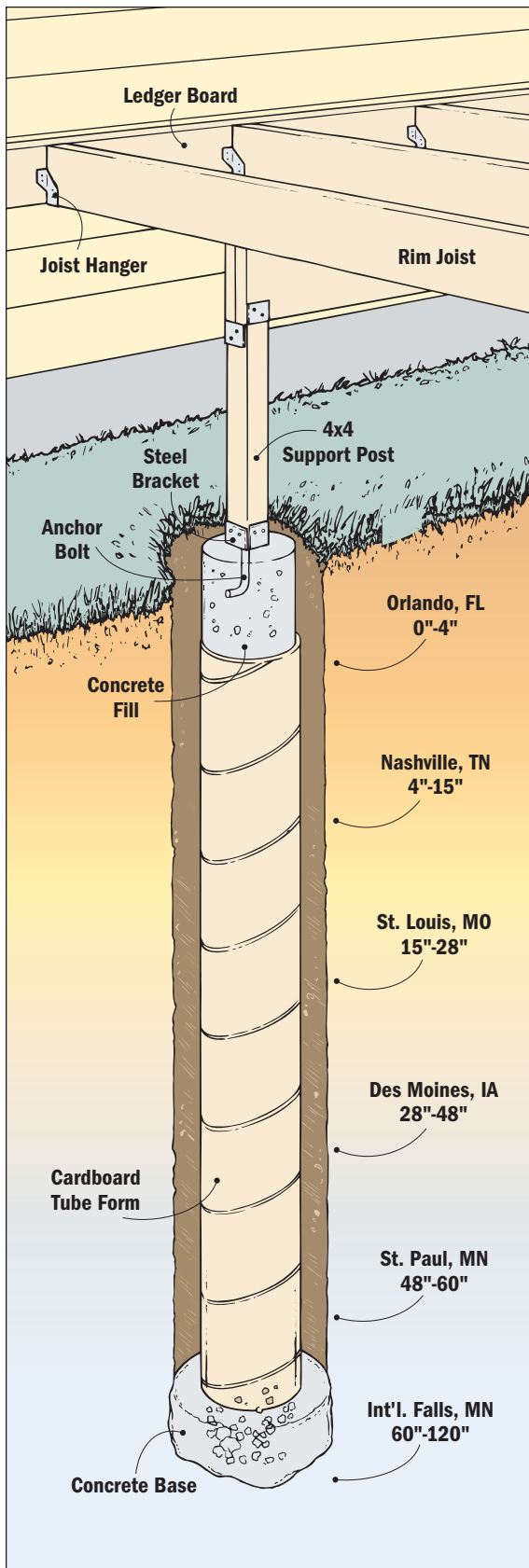

Frost Footing Zones

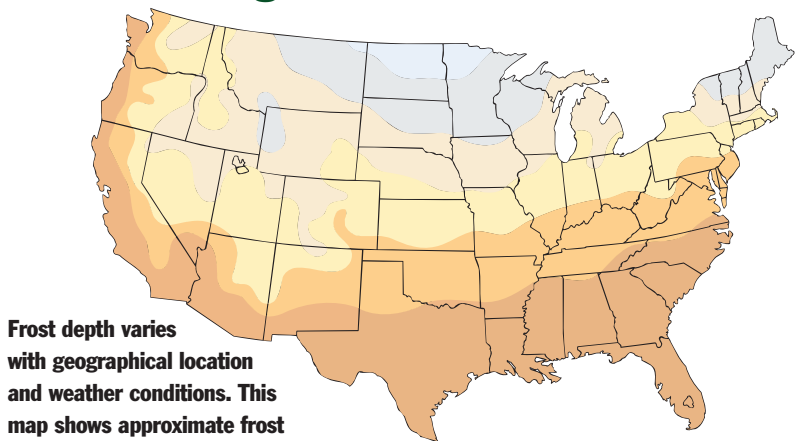

Frost depth varies with geographical location and weather conditions. This map shows approximate frost depths for different regions.

0"-4"	4"-15"	15"-28"	28"- 48"	48"- 60"	60"-120"

Why Do My Band Saw Blades Keep Breaking?

Q My band saw blades keep breaking when I'm cutting curves. What am I doing wrong?
*Troy Gallagher
 San Antonio, TX*

A Assuming the tension is set correctly on your band saw (check the owner's manual for proper tuning), I'd say your problem is one of two things. Either you're using the wrong width blade or you're feeding the stock too fast.

BLADE WIDTH

Just like with table saw blades, there isn't a band saw blade that will do everything perfectly. The chart below shows the minimum radius each width blade can turn without binding. (You might want to keep a copy of it near your band saw or where you store blades.) As a rule, the narrower the blade, the tighter curve you can cut.

Attempting to squeeze a blade through a turn that's too tight can result in a number of problems. The blade can break, the teeth may get twisted into the guides and become dull, or the blade can be pulled off the wheels of the saw.

So why not just mount a narrow blade (such as a 1/4"-wide blade) on your saw and cut all curves with that? Well, a narrow

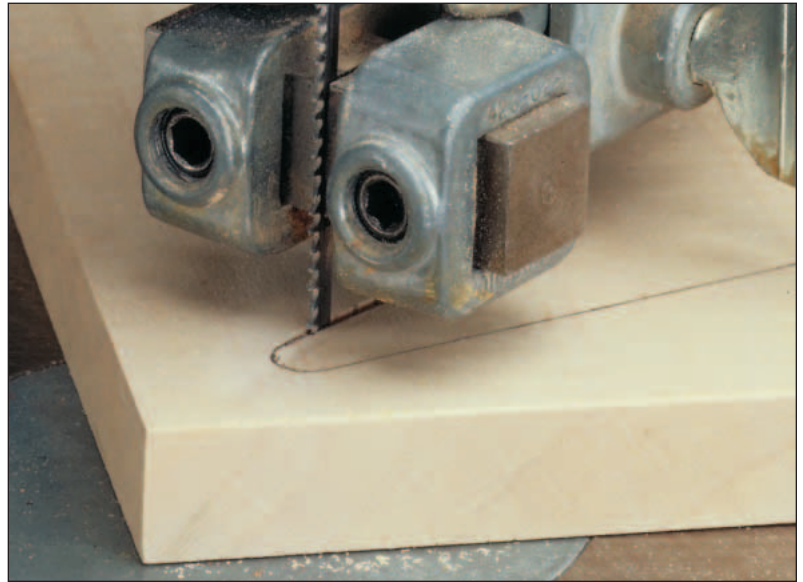

blade has more tendency to wander off course than a wide blade. If you try to cut a large radius, such as a circular tabletop for example, you'll have a hard time keeping the blade from straying from the line.

With practice, you should be able to cut most curves with a 1/4"- or 3/8"-wide blade, except for the really tight ones.

FEED RATE

Although you need a narrow blade to cut tight curves, you also need to match the feed rate to the thickness of the workpiece. The thicker the piece, the slower the rate of

feed. When making a curved cut, it's easier to follow a layout line more precisely if you don't hurry. If you take your time and cut slowly, you'll also have less clean-up later on.

When smoothness and precision aren't as important, you can feed the stock quicker. Just don't push it too hard. This builds up excess heat and can cause the blade to break.

You should decide which is more important: speed or smoothness. Feeding the stock at a slow, steady rate usually works best. This allows the blade to do its job — cut smoothly and clear out the sawdust.

HOW BLADE WIDTH AFFECTS CUTTING RADIUS

The minimum radius that you can cut on your band saw is determined largely by the width of the blade.

For example, a 3/4"-wide blade can cut a 5 7/16" radius, while an 1/8"-wide blade can cut an 1/8" radius.

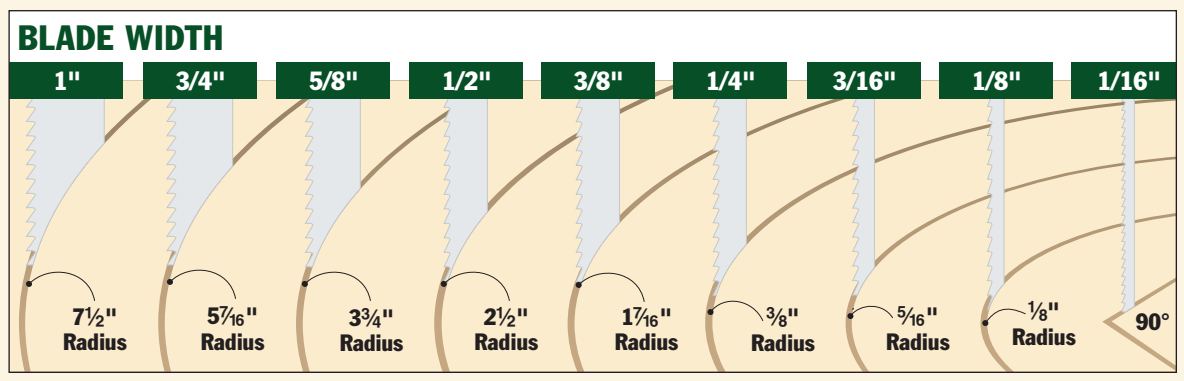

Removing Decay and Repairing a Window Frame

Q I need to repair an inside corner of an old window that has rotted. I've tried scraping it without much success. How can I remove the decayed wood without dismantling the entire window so I can repaint?

Joseph Fullmar
Greenwood, WI

A First things first. Before you make any repairs to the window, you should find and stop the cause of the rot. After that, you'll want to carefully dig out all of the deteriorated wood with a chisel.

Once it's completely dry, the rotted area can be rebuilt with a filler. Automobile body compound such as Bondo (available at automotive supply stores) is an excellent choice for repairing rotted wood. It dries quickly, sands easily, and creates a strong bond. Use a waterproof compound that contains fiberglass.

One way to hold the filler in place as it hardens is with two thin splints clamped tight against the window frame (see photo). You can rub paraffin wax on the splints so the Bondo doesn't stick to them. After mixing equal parts of the

filler and hardener, use a scraper to pack and spread the mixture into the rotted area. Once mixed, auto body filler has a short life before hardening — only a few minutes — so work quickly. Don't worry about overfilling. Let the repair dry overnight before removing the splints and sanding the corner square and flush.

To finish, scrape the remaining paint off the entire window (both sides), then brush on a coat of top-quality alkyd primer. Follow that with two coats of a good latex paint that contains a mildew inhibitor (check the can). You can also buy a mildew inhibitor additive for paint such as Super Mildex at home centers and paint stores. Once repainted, the repair will probably outlast the rest of the window.



What's the Best Way to Attach Drywall to a Curve?

Q I want to attach drywall around a curved wall. What size panels should I use, and how can I get the drywall to bend without breaking?

Sean Miller
via the Internet

A I suggest using two layers of flexible 1/4"-thick drywall. (You might have to special order it.) Two layers should provide plenty of strength and will blend in with regular 1/2" drywall. Flexible drywall has a heavier paper face than

regular drywall, which helps it resist cracking. If needed, you can make it even more flexible by wetting it (see the chart below).

Using a paint roller, soak the side that's going to be compressed (face side for a concave wall; back side for a convex wall). Use about 30 oz. of water for each 4x8 panel. Stack the panels with the wet surfaces facing each other and let them sit for at least one hour before attaching.

Start by measuring the distance on *both sides* of the wall (they'll be different). And check stud spacing. You may need additional framing to prevent flat areas between studs (see the chart). For a concave wall, start attaching at the center studs and work toward the ends. On convex surfaces, start at one end of the wall and work across (see below).

Concave: Start fastening in the center of the curve and then work out toward the edges.

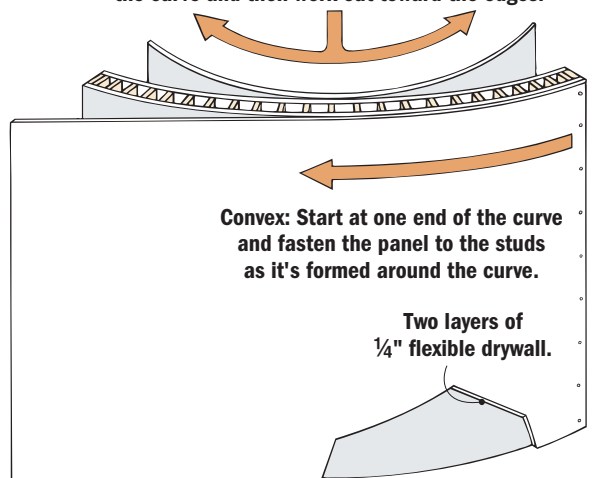

Convex: Start at one end of the curve and fasten the panel to the studs as it's formed around the curve.

Two layers of
1/4" flexible drywall.

BENDING DRYWALL

The information below shows the minimum bending radii for 1/4" flexible drywall panels (attached lengthwise).

TYPE OF CURVE	WET/DRY	MIN. RADIUS	MAX. STUD SPACING
INSIDE (CONCAVE)	DRY	32"	9" O.C.
INSIDE (CONCAVE)	WET	20"	9" O.C.
OUTSIDE (CONVEX)	DRY	32"	9" O.C.
OUTSIDE (CONVEX)	WET	15"	6" O.C.

Tips & Techniques

FEATURED TIP

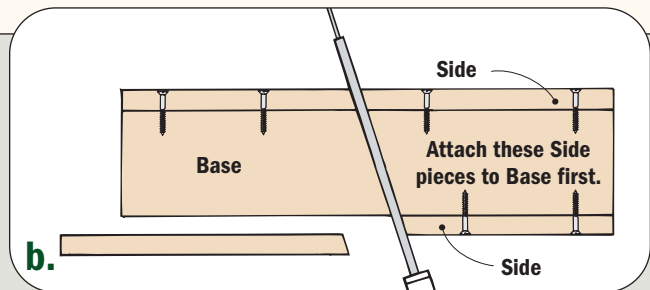
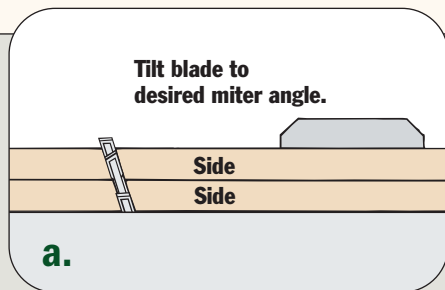
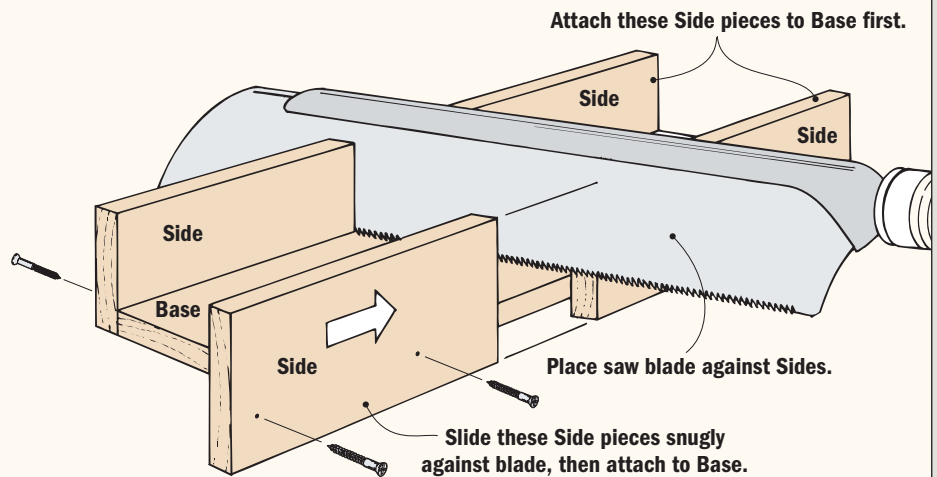

Custom, Thin-Kerf Miter Box for Delicate Cuts

Miter saws are great for cutting moldings. But if you need to cut short pieces, like returns, a power miter saw can send the piece flying. They can also chew up delicate moldings.

After a few unsuccessful attempts, I got out my old wooden miter box and my Japanese-style pull saw. (These saws give you great control and a smooth cut.) Then I realized the guide kerfs in the wooden miter box were much wider than the thin blade of the pull saw.

To solve the problem, I made a new miter box from three pieces of scrap wood. First, I carpet taped the two side pieces together

with their ends flush. With my table saw blade tilted to the angle I needed, I cut the two side pieces in two (Fig. a).

After separating the two of the side pieces, I screwed them to the base, making sure to keep the ends of all three pieces aligned. Then I placed the pull saw in position against the assembled sides and butted the remaining side pieces snugly against the blade (Fig. b). A clamp helps hold these last two side pieces in place while you screw them to the base.

The miter box may be a bit tight the first time you use it, but the saw will widen the kerf so the blade doesn't get pinched. And

since the blade is tensioned on the pull (cutting) stroke, there's less tendency for it to bind.

This tip also works great for traditional back saws or when you need to cut an odd angle. You follow the same process and just adjust the tilt of your table saw accordingly.

*George A. Person
Costa Mesa, CA*

Workbench congratulates George Person for submitting this issue's Featured Tip. In recognition of his tip, George will receive \$250 worth of tools from The Stanley Works. 

Shingle Gauge Speeds Nailing

When using an air-powered roofing nailer for the first time, I found the gun's built-in nailing guide awkward to use. When I hooked the guide against the bottom edge of the shingle I was attaching, the shingle often shifted out of position.

After realizing the placement of the nails wasn't as critical as keeping the shingle lined up, I made a simple shingle gauge. It's a piece of $\frac{3}{4}$ " plywood with a $\frac{1}{2}$ " by $1\frac{1}{2}$ " wooden cleat fastened to the underside of the plywood. The distance from the cleat

to the top edge of the plywood matches the shingle reveal.

To use the gauge, I butt the cleat against the previous row of shingles and lay the shingle to be installed with its bottom edge against the top of the gauge.

The shingle doesn't shift around, and I can quickly nail it in place without worrying about the guide.

*Scott Kingery
Jefferson, IA*

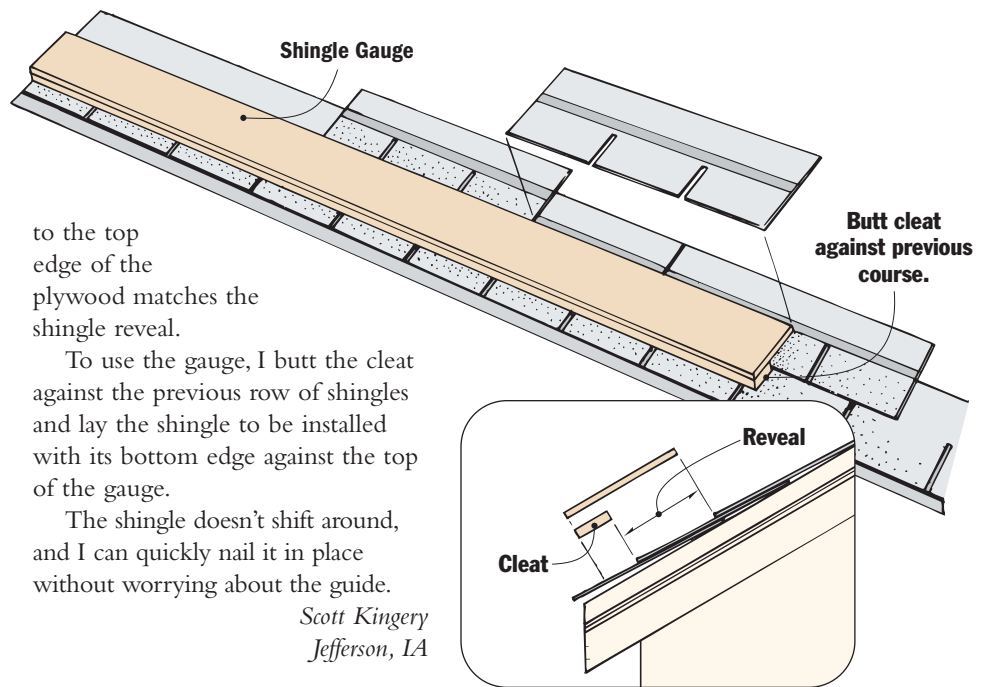

Jig Allows One-Man Siding Installation

Handling a sheet of T1-11 siding by yourself isn't difficult, until you try to install it. Then it's next to impossible to hold it in position while you nail it down.

But sometimes you have to work alone, so I came up with a jig to help me install sheets of siding. The jig is just a short length of 1x4 with cleats screwed on opposite sides at the ends, as shown at right. One cleat — a piece of 2x4 — hangs on the stud wall plate and the other holds up the siding. The distance between the cleats establishes the proper siding overhang along the bottom of the wall.

To use the jig, I position it on the plate near where the outer edge of the sheet of siding will land. Screw tips protruding through the plate cleat help hold it to the wall plate.

Next, I lift the sheet of siding onto the jig, align the edge with the previous sheet, and drive a few nails along the top end to hold it in place. That lets me pull the bottom end of the siding out far enough to remove the jig. Then I finish nailing the siding in place.

*Richard Ball
Kernsville, NC*

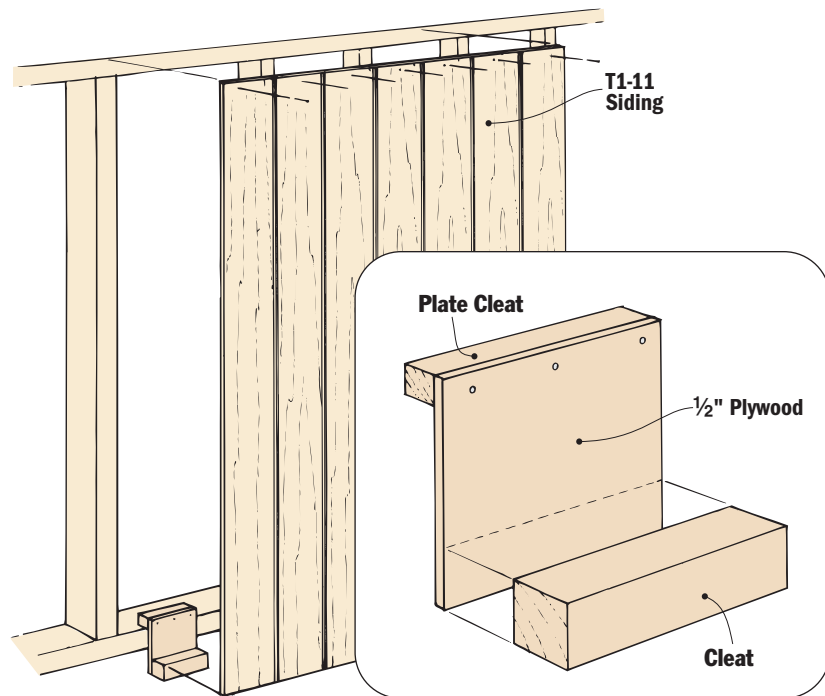

Share Your Tips, Jigs, and Ideas

Do you have a unique way of doing something? Just write down your tip and mail it to:

Workbench Tips & Techniques
2200 Grand Ave.
Des Moines, IA 50312.

Please include your name, address, and daytime phone number.
If you prefer, e-mail us at:
Editor@Workbenchmag.com

You'll receive \$75-\$200 and a **Workbench** hat if we publish your tip.

Also, The Stanley Works will award \$250 in Stanley Tools for the Featured Tip in each issue.

For a free woodworking tip every week via e-mail, go to
WoodworkingTips.com.



FILL AMOUNTS

Approximate R-value/inch equivalents for blown-in cellulose insulation.

R-VALUE*	INCHES
R-10	3.0
R-20	5.5
R-30	8.5
R-40	11.5
R-50	14.0

*R-values change with extreme conditions.

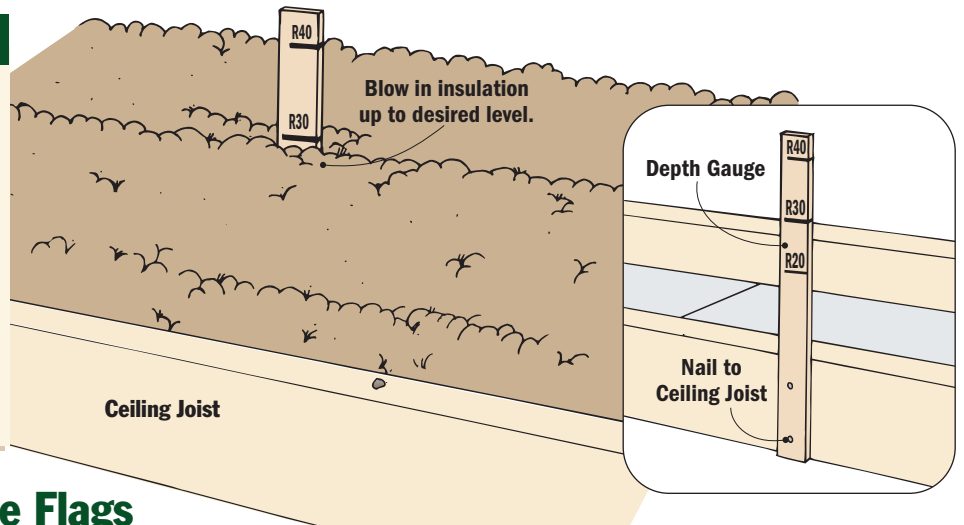

Fill 'Er Up to the Flags

I've worked on a number of Habitat for Humanity houses and have a trick I use to know how much insulation has been blown into the attic. Once the framing is done, but before the ceilings are rocked, I tack a gauge stick to every third or fourth rafter or truss cord.

The length of the gauge sticks can vary depending on the R-value (the depth of the insulation) I want to achieve. For our climate, the gauge sticks are typically 13"-long pieces of lath with the top 1" painted with bright fluorescent spray paint. I tack them in place to the rafters/ceiling

joists with the painted end sticking straight up and the other end flush with the bottom of the rafter.

Once the ceiling has been installed, cellulose insulation is blown in. Just fill it up to the painted ends.

*Ralph Craig
Tipp City, OH*

Wipe Jars for Clean, Straight Brushes



If you just stand a paint brush up in a can or jar of paint thinner, you wind up with a worthless brush because the bristles are curled.

Your brush is better off if you can suspend it in the thinner, but this often requires drilling a hole in the brush handle. Even then, it's hard to put a lid on the container with the brush in the way.

Since I'm big into recycling, I found a use for those plastic "jars" that pop-up disinfectant or baby wipes come in. The lids already have an expansion hole in the top, which makes it easy to insert the brush handle. The hole grips the handle firmly and with the lid snapped in place, the brush stays suspended and the thinner doesn't evaporate nearly as quickly.

*Chris Cannon
Thunder Bay, Ontario*

Make Miter Saw Table Non-skid

Sometimes I have a hard time holding a workpiece steady on my miter saw. Crown molding in particular wants to slip away from the fence when you stand it up on edge.

Taking a cue from my non-slip router mat, I bought a roll of thin non-skid rubber shelf liner. By placing a piece of the liner on the table of the miter saw, the workpieces stay put.

When cutting long pieces, put some of the shelf liner material

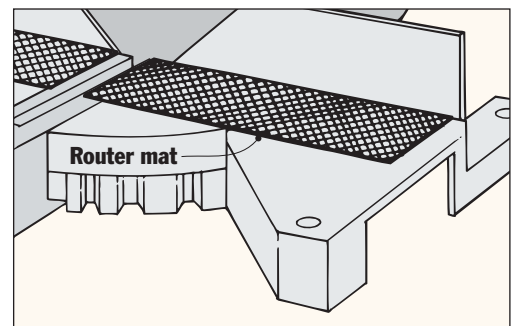

under the outer end to help keep the workpiece level. Just roll it for storage when you don't need it.

*Anna Victoria Reich
Albuquerque, NM*

Turn Over Leaves for a Better Grip

After years of use, my pipe clamps seemed to slip when I tightened them. I discovered the edges of the leaves in the sliding jaw were worn and had lost most of their grip. To renew the clamps, I simply removed

the head from the pipe. Then I took out the spring and the leaves and turned the leaves around. The leaves' crisp "new" edges have plenty of bite.

*Omar Showalter
Harrisonburg, VA*



Old-Fashioned Service Meets New Media

I enjoy a good woodworking book as much as the next guy. But I never thought buying books would make a very interesting feature for this department — until I found Woodbooks (www.Discount-Books.com).

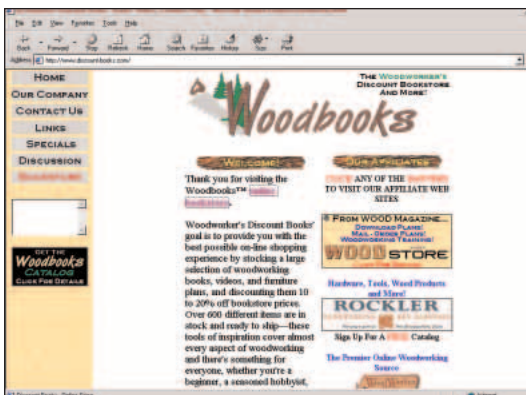

Woodbooks is a Colorado-based bookseller that specializes in woodworking titles. Although they're small, their catalog includes nearly 800 titles.

The first thing I really liked about this site is that it deals only in woodworking-related titles. So you don't have to navigate through a bunch of nonsense to find what you're looking for. Simply type the title or the subject you're looking for into the search engine. And once you find the book or video you want, buying it is simple. There are no forms to fill out, and I never felt like I was trading my privacy to buy a book.

Another piece of good news is that the prices at Woodbooks seem pretty competitive. I bought three

books from the site and then, just for comparison's sake, checked the prices of the same books at one of the super sites. All tolled, I saved about \$4 at Woodbooks.

As for customer service, it can't get much better. Just give them a call. You'll probably wind up talking to Alane Sheaves, who owns and operates the company from her home. She and her husband are both woodworkers — though she seems reluctant to call herself that, since she's a beginner.

Just the same, she's got a real appreciation for the subject matter. It shows in the way she runs her business.

Next time you're looking for inspiration or instruction, drop by Woodbooks first.

Nothing But Wood @ www.Hardwood.org

Many of the sites I look at for WorkbenchInteractive.com suffer from trying to do too much. For whatever reason, there's a tendency to try to build sites that are all things to all people.

Occasionally, though, I come across a site with a clear, concise mission. One of my favorite examples is the Hardwood Information Center (www.hardwood.org).

The site is an extension of the Hardwood Manufacturers Association, and it's set up purely as an information resource. They're not selling anything, and there's no propaganda that I can see.

What the site does have are some great facts about hardwood. In particular, the Species Guide is helpful. By clicking on a picture of the species you want to learn about, you're given a page that explains everything from the wood's history

to its strength and mechanical properties. There's also an example of a typical grain pattern for each species and a photo of the wood in a project.

The site also has several articles on using hardwood in your own projects. You can even sign up for e-tips to be sent directly to your mailbox. (These seem to be condensed versions of the articles, for the most part.)

This site is one of the best I've seen for presenting useful information in a nicely organized package. It's a good place to just browse around or research anything you need to know about domestic hardwoods.

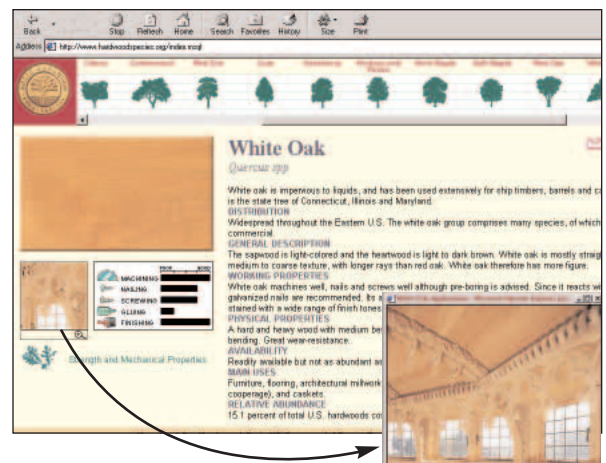

Species (Kiln-Dried)	Pressure to Mar (In Pounds)	Species (Kiln-Dried)	Pressure to Mar (In Pounds)
Hickory, Pecan	1,820	Hackberry	880
Hard Maple	1,450	Gum	850
White Oak	1,360	Elm	830
Beech	1,300	Sycamore	770
Red Oak	1,290	Alder	590
Yellow Birch	1,260	Yellow Poplar	540
Green Ash	1,200	Cottonwood	430
Black Walnut	1,010	Basswood	410
Soft Maple	950	Aspen	350
Cherry	950		

Easy, Affordable, Computer Aided Drafting Software

One of the most common requests I get from readers is for a Computer Aided Drafting (CAD) program that would be good for woodworkers. It's also been one of the toughest requests to fill.

Up until recently, I hadn't found any programs I could recommend.

Either the price was too high — several hundred dollars for some of them — or they were too hard to use.

Recently though, I stumbled across a program called Delta Cad. It's not a new program; it's been available for about five years. I just hadn't heard of it before. Now that I've found it, I can't say enough good things about it.

To begin with, it only costs \$39.95. (There's a free trial version available for download from www.dcad.com.) But besides being very affordable, the program is remarkably easy to use — at least for a CAD program.

That raises an interesting point. Even the simplest CAD program — and this may be it — is going to have a moderate learning curve to it. It doesn't have to be intimidating, but it's not as easy as a word processor or a game of solitaire. With a little time and experimentation, though, just about anybody should be able to create some real

quality drawings with this program.

I got started by downloading the trial version. After floundering around for a bit, I opened up the "Help" feature on the program to see if I could find some direction. Under the heading "Tutorial," I found something called "Learning Delta Cad."

It turned out to be step-by-step instructions to draw a front view of a calculator. (The same tutorial is in the manual that comes with the full version.) It took me about 45 minutes to get through the entire tutorial. The end result was a calculator that mirrored the real thing.

With just what I learned in the tutorial, I've already used the program to draw three projects: a nightstand, an entertainment center, and a router table. It really couldn't be simpler.

THE SOURCE

The software can be purchased online at www.dcad.com, or you can fax your order to (206) 361-0796. Mail orders should be sent to:

Midnight Software, Inc.
P.O. Box 77352
Seattle, WA 98177-0352

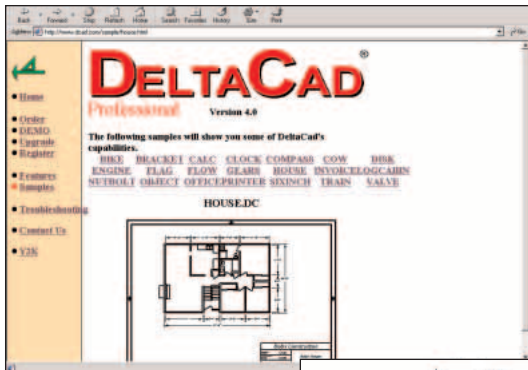

A tutorial that's included with the program guides you through drawing a calculator like the one at right. Once you've completed the tutorial, you've got the basic skills to do original drawings.

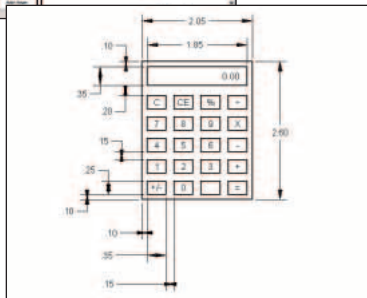

Project Calc Offers A New Solution To Old Problems

Talking about a pocket calculator in WorkbenchInteractive.com might be a bit of a stretch, but this is one of the best new products I've seen in a long time. I had to find some place in the magazine for it. And it's enough like a computer that I thought I'd wedge it in here.

The reason I like the Project Calc so much is that it makes easy work of one of my least favorite things — shop math.

In particular, it handles fractions in a way that makes sense. No more trying to remember what the decimal equivalent of $\frac{13}{16}$ is — just punch it into the calculator as a fraction and it appears as a fraction on the display. It even shows dimensions

in feet and inches instead of making you do the division to figure it out. In short, this calculator is a fast — and almost foolproof — way to crunch project numbers.

It also has a thoughtful design with a large, easy-to-read display screen and big buttons that are spaced far enough apart that you can press them with gloved fingers. It even has a quick reference guide on the inside of the protective cover that explains how to make some of the more common calculations.

The Project Calc is available at Calculated Industries Web site (www.calculated.com) for \$24.95. But check local electronics stores for a bargain price — I found mine at Radio Shack for \$19.95.

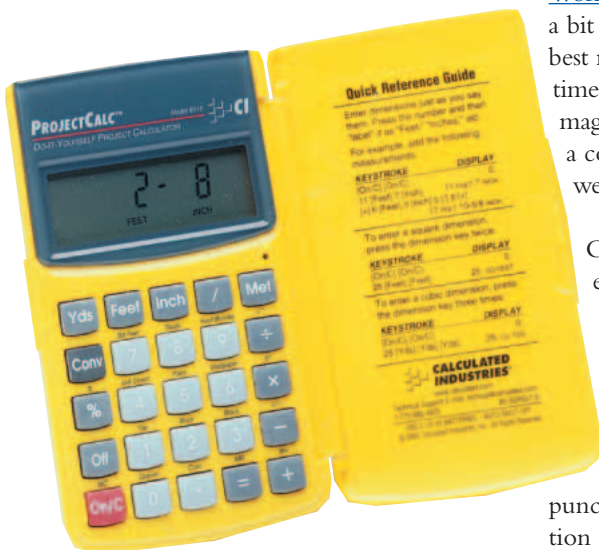

Quick Poll: Router Results

In honor of the plunge router review article on [page 30](#), I decided to ask visitors to [WorkbenchInteractive.com](#) how many routers they own. Here's how they answered.

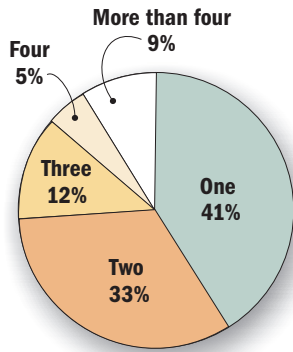

New Quick Polls go up on the Web site all the time, so visit [WorkbenchInteractive.com](#) often to take part in them.

“Burning” Question in the WW Forum

I'm tired of sanding all the burn marks left by my table saw. Can someone recommend a good blade that won't hurt my wallet?

— *Jasen*

If you're getting a lot of saw marks or burn, chances are the cause isn't the blade as much as it is a misalignment of your fence. Set your fence and measure from a tooth at the front of the blade to the fence. Then rotate the blade back and measure from the same tooth to the fence at the back of the blade. Betcha' the back is tighter than the front. If you re-align or change the fence, the problem will go away.

— *MadMark*

Burn marks can be caused by several things besides poor fence alignment:

1. Too slow of a feed rate.
2. Too fine of a tooth on the blade.
3. Table saw trunion out of alignment.
4. Dirty or pitch-covered blade.
5. The stock — some stock (such as cherry) is very prone to burning.

— *Jim Tincher*

The *Interactive* solution: To help Jasen out, I've posted some table saw tune up tips along with a trouble shooting guide on [www.WorkbenchInteractive.com](#). Look for it under the “What's New” heading. Hope it helps.

In The Shop

Routing Stopped Chamfers and Grooves



No matter what you're building, it's the details that really separate a great project from an average one. In both the *Deck Railing Redo* and the *Heirloom Bed*, for example, we used stopped chamfers to dress up what otherwise would have been plain, square posts.

If you look at the posts, the sharp, square edges ease into the

chamfer. That may look tricky, but the chamfering bit actually does that on its own.

The secret to these and any "stopped" cuts is getting them to all start and stop at the exact same location. Whether you use a handheld or a table-mounted router, here are two methods that will help keep your cuts on track.

HANDHELD METHOD

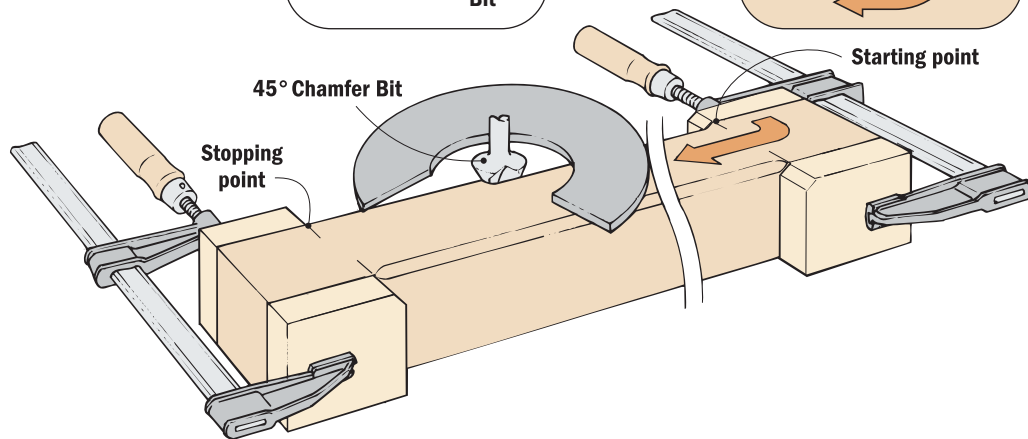
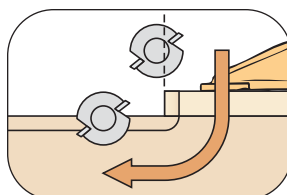
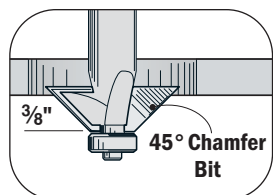

HANDHELD ROUTER METHOD

When you're working with pieces large enough to provide support for the router's base, it makes sense to use a handheld router. That's the technique we used for the bed legs and the edges of the deck posts.

Start by marking lines at the starting and stopping points. Then clamp some pieces of scrap to the post as shown at left. The scrap should be the same width/depth as the post and align with the marks you made.

When you rout, the bit's guide bearing follows the scraps, so the cutting edge enters and exits the wood exactly where it's supposed to.

ROUTER TABLE METHOD

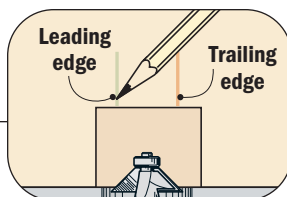
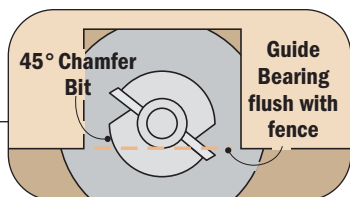

Align starting point with leading edge to start chamfer.

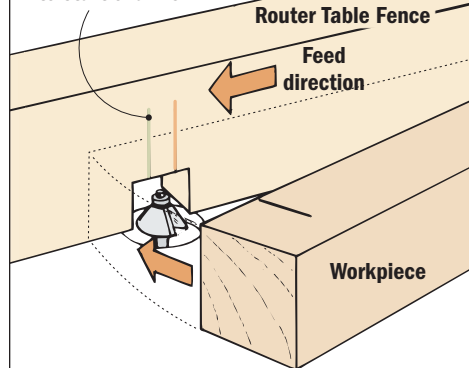

Half chamfer cut when stopping point aligns with trailing edge.

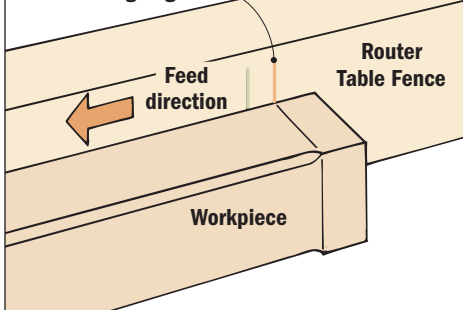

ROUTER TABLE METHOD

For smaller pieces or when you've got a lot of them to do (such as the deck balusters), using a router table makes more sense.

You still start by marking the starting and stopping points on your stock. But you use marks on the router fence to guide the cuts.

With the bit depth set and the bearing flush with the fence, use a square to mark the leading and trailing edges of the bit on the fence. To start the cut, ease the stock into the bit so the starting point aligns with the leading edge mark. Then rout until the stopping point aligns with the trailing edge mark.

GRID METHOD

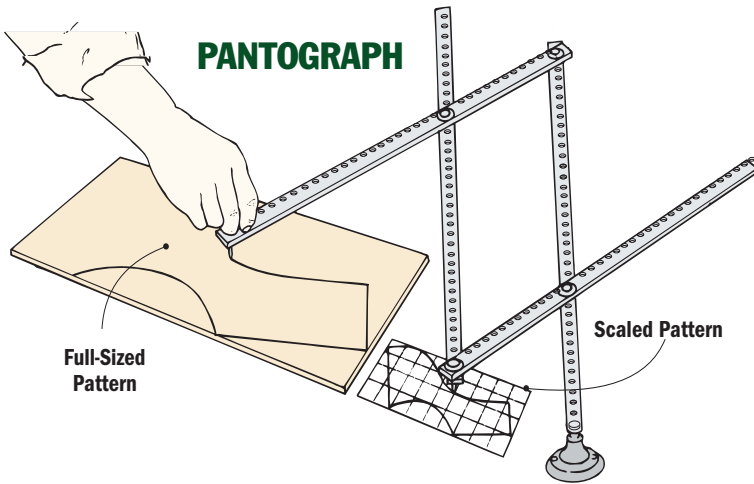
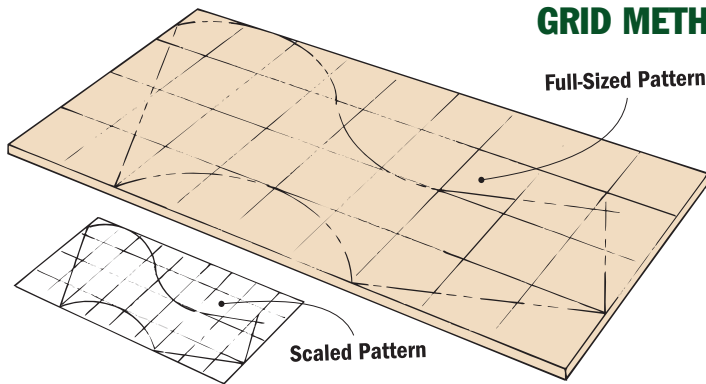

Enlarging Patterns: Super-Size It

A number of the projects featured in *Workbench* have scaled patterns to assist you in duplicating the shape of curved parts. Sometimes you can just blow these up on a copier to get a full-sized pattern.

But what if a guy doesn't have access to a copy machine or the part is too big to fit on letter-sized sheets? You've got a couple of options.

One way is to lay out a full-sized grid and make a "dot-to-dot" outline.

Typically, the drawing will have a note that says that each square shown equals 1". For example, the bed leg pattern on [page 43](#) says that each of the pattern's 1/4" squares equal 1". So it's a one-fourth scale drawing. (You might also see this shown as a 1:4 ratio.)

As long as the actual size is given in 1" dimensions, the scale isn't that important. Just count how many squares wide and tall the pattern is, then lay out a grid of 1" squares.

To start enlarging the pattern, first identify any "critical" points on

the pattern, such as straight lines or places where the pattern piece joins with another part. Next, look for each place the pattern line crosses a grid line.

Once you've marked all the points where the pattern crosses a grid line, start connecting the dots. If your curves aren't smooth, you can use a drafting tool called a French curve to smooth things out. Bending a thin strip of wood along the pattern will do the same thing.

The other way to enlarge patterns is to use a pantograph (see the drawing above). Depending on how the bars are connected, the pantograph will reproduce patterns at different scales. You fasten down both the pattern and a sheet of paper large enough for the full-sized drawing.

Trace around the pattern with the pantograph. The longer arm will create an enlarged image of what you're tracing. The steadier your hand, the more accurate the full-sized drawing will be.

Matching Grain Is Worth the Effort

Many projects require parts wider than available stock. So, we glue up several narrower pieces to get the necessary width.

The key is to still make it look like a single, wide piece of wood. By carefully matching the grain, the glue joints “disappear,” giving the entire project a more professional look.

If you’re lucky enough to find lumber that’s still stacked straight from the mill, the job is easy. The color and grain patterns will match because the boards likely came from the same log.

Since you can’t count on luck, look for boards with the same general type of grain patterns. Flip them

over and spin them end for end to see if you can find a match, sort of like fitting jigsaw puzzle pieces.

Look at the two photos below. We glued the same two boards together in both cases. The only difference in the “Good Match” is that we spun the board on right 180° and glued it on its other edge.

Ideally, the color should match as well. But if you find a good grain match, stain can help make slight color variations more uniform.

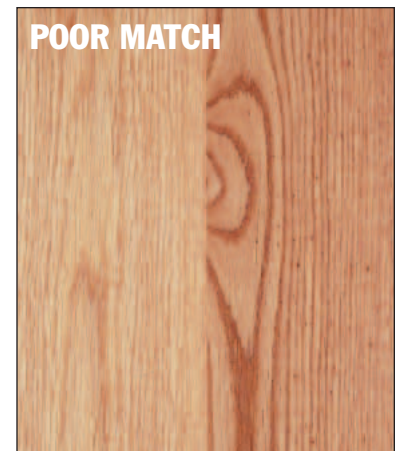

The board on the right has a figured spot where an intersecting branch grew. It clashes with the straight grain.

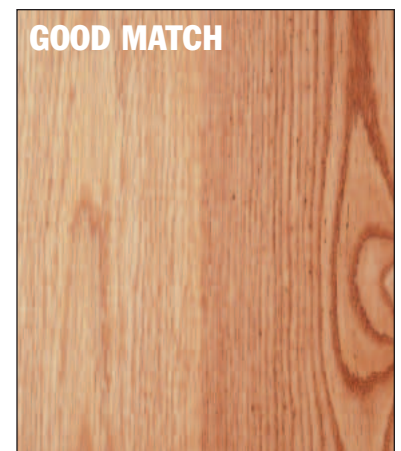

Even though the color varies slightly, the grain in the same two boards matches much better in this orientation.

Revive Your Deck

A thorough cleaning and fresh stain can make a tired deck “new.”



Decks really take a beating. Exposed to the sun, wind, and rain with little or no protection, it's a small wonder they seem to turn gray and shabby in just one season.

The good news is that unless you've really neglected it, even the grungiest deck can be brought back to life. All it takes is the right

cleaner, the right finish, a few days time, and a little bit of elbow grease.

WHY WOOD WEATHERS

Water is wood's biggest enemy. The constantly repeating wet and dry cycles mean the wood is always expanding or contracting, particularly near the surface. Over time, this constant movement begins to loosen

the surface wood fibers. In more northern climates, you have the added impact of freeze-thaw cycles.

Combined with the sun's ultraviolet rays, water eventually breaks down the wood fibers near the surface. Dirt and mildew collect on the damp, damaged surface, further darkening the wood. Left unattended, these conditions eventually



BEFORE CLEANING



AFTER CLEANING



1

Look beneath the deck to check for structural problems. In particular, look along the tops and ends of the joists.



2

Check for loose knots or damaged boards. In extreme cases, glue down the loose sections with epoxy.



3

Remove damaged or rotten wood to prevent the damage from extending to other parts of the deck.

lead to bigger problems such as rot and structural failure. At the very least, it's not a pretty sight.

LOOK FOR PROBLEMS

Before you do anything, give the deck a thorough inspection, top and bottom. Check for damaged or rotted boards, loose knots, or popped fasteners (Fig. 1 and Fig. 2). If you can see under the deck, check near the top edges of the joists for damage as well as along the ledger board where the deck fastens to the house.

If you find a rotted plank, it's best to remove it and replace the entire plank (Fig. 3). This also gives you a chance to see if the rot has extended to the structure below.

In my case, the railing was so badly weathered, as well as outdated, I decided to replace it (see *Deck Railing Redo* on page 22).

Removing the railing gave me an advantage when it came time to fix some of the other problems. Since the decking had been nailed down with common galvanized nails (instead of ring-shank nails), many of the nails had worked loose, particularly at the ends of the planks. So I pulled those nails and replaced them with 3" hot-dipped, galvanized deck screws (Figs. 4 and 5).

For some stubborn nails that were still tight, it helped to pry the end of the plank up, as a way to pop the nails loose (Fig. 4). A catspaw bar could also be used to lift the nail's head enough to get a claw hammer under it. (Not all prybars are alike — find out why in *Leveraged Pryout*.)

I also used a nail set to drive the remaining popped nails back in place. It's a tedious job, but you quickly develop a rhythm. You'll be

surprised how much this tightens up a deck, eliminating squeaks and that springy feeling under your feet.

When you've got everything tightened back up, the deck is ready for a thorough cleaning.

LEVERAGED PRYOUT

Most home projects don't require heavy demolition, but a good prybar still comes in handy. Though the general shape is the same, the prybars shown here are designed for slightly different uses. The two "Wonder Bar"-type tools at left are good, general-purpose prybars. The thin, wedged-shaped blades can be slipped into a narrow gap without damaging the wood.

As you can see, the second one is forged (not stamped) so it's stronger and the longer length provides more leverage.

The thicker-bladed "crowbar" (center) is for prying where you're not concerned about damaging the workpiece — you just want it apart. The catspaw, with its curved claws, is good for lifting nail heads. The bar's head is shaped to allow you to tap it with a hammer to get under the nail head.

For removing trim, a small "Handy-bar" (right) is just the ticket.



4

Lift the end of the plank, then tap it down to leave the nail heads exposed. Replace any rotted planks entirely.



5

Drive 3" galvanized (hot-dipped) screws at the deck's perimeter. Elsewhere, set the nails flush with the deck surface.





6

Before you start cleaning, mask off the siding with plastic, and cover nearby plants as well. A bucket is

handy, especially if you need to dilute the cleaner with water. Let the cleaner soak in, then scrub to remove dirt.

GETTING IT CLEAN

How you clean your deck depends on what type of finish is (or was) on it. For most decks, that means some type of water-repellent or oil-based stain. To clean a deck with one of these finishes, you'll need a liquid deck cleaner, a brush, and a hose.

If the deck had paint or another type of "film" finish, you'll need to use a stripper, a power washer, or a sander to get down to bare wood. (Find out more about cleaners and finishes on the [opposite page](#)).

Before using any type of cleaner, cover any nearby bushes and the siding with plastic sheeting (*Fig. 6*). Since most cleaners contain either bleach or acid, wear old clothes, rubber gloves, and eye protection.

Depending on the type of cleaner used, you can spray it on with a plastic hand-pump sprayer or simply swab it on with a mop or brush. Sprayers make it easier to get the cleaner down into the gaps between the decking boards.

Since my deck was heavily mildewed, I started off with a chlorine-based deck wash. After a thorough rinsing, I followed up with an oxalic acid-based brightener.

This second step served several purposes. It removed some rust stains from around the deck fasteners and brought the wood back to a more natural color.

The acid also neutralized the alkaline residue from the chlorine deck wash. If you don't do this, the

bleach mixtures will break down the wood's natural internal "glue" (or lignin), later preventing finishes from soaking in properly.)

After a second, thorough water rinsing, you need to let the deck dry out completely (at least two days) before moving on to the finish stage.

CLEAR FINISH OR STAIN?

With a clean, dry surface, you're ready for finish. For decks, you want a penetrating, oil finish that provides water repellency. These come in clear, semi-transparent (semi-opaque), and solid-color stains.

Since my deck was built from pressure-treated lumber, I chose a semi-opaque stain. The cedar-tone let me bring the deck closer to the color of the new cedar railing I planned to install.

It's important to follow the instructions on the can regarding keeping a wet edge. Initially, I tried to work too large an area (*Fig. 7*). One spot dried, resulting in a lap mark when I tried to blend the finish in.

I found it worked best to use a paint roller and do one or two rows of planks at a time, working from one end to the other. If you wind up with more stain on a plank or two, they just look like darker boards.

Also, try to work the finish down between the planks (*Fig. 8*), not only for consistent color, but to protect those areas as well. Give the ends an extra soaking to slow down water absorption through the end grain.



7

With semi-transparent or solid-color stains, maintain a wet edge to prevent lap marks. A paint roller on an exten-

sion handle lets you quickly apply a generous coat of stain without much bending over.



8

For added protection, work stain into cracks between deck boards. If it's exposed, stain the underside as well.

Products to Clean and Protect

CLEANERS

There are dozens of commercial deck cleaning products available as well as do-it-yourself recipes. But what's safe to use and which type is best?

Maybe the easiest way to understand deck cleaners is to think in terms of laundry products.

• **Chlorine-based bleaches** (look for sodium hypochlorite on the label) are for heavy-duty cleaning. They're great at killing mildew spores, but they'll take the color out of your deck the same way they'll turn blue jeans white.

• **"Oxygen" bleaches** (sodium percarbonate which forms hydrogen peroxide when added to water) are milder, like the color safe laundry bleaches. They aren't as aggressive so they may take a little more scrubbing. These cleaners also aren't

as effective at getting rid of mildew spores.

• **Oxalic-acid based cleaners** are the third type. These are great for removing stains, similar to Whink or other rust stain remover laundry products.

These are particularly good on cedar and redwood which contain high concentrations of tannins. Tannins are water-soluble resins that leave dark stains as they find their way to the wood's surface.

With any of these cleaners, it's important to wet down the wood and surrounding area before applying them. Then rinse the deck thoroughly to remove cleaner

residue, loose wood fibers, and remaining dirt. This helps insure a good bond between the new finish and the deck.



STAINS

All good deck finishes contain some type of water repellent, since water is a deck's biggest enemy. The best ones are penetrating finishes. They use solvents to absorb deeply into the wood taking a sealer (such as linseed oil) and a water repellent (usually paraffin wax) into the wood as well.

Sorting out the differences between clear waterproofers and semi-transparent or solid color stains depends on the look you want and how long you want it to last.

• **Clear finishes**, often called water repellents or water repellent preservatives, are ideal for cedar or redwood where you want the natural color of the wood to show. The "preservative" products simply have a mildewcide added to slow down mildew growth.

• **Semi-transparent stains** are similar to the water-repellent preservatives, but have pigment added. The small pigment particles create a tougher surface finish without form-

ing a film that could crack and peel. Besides toughness, the pigment also provides greater protection from the sun's UV rays. It's also a way to add color to a deck while still being able to see the wood's grain.

• **Solid-color stains** provide even greater protection against UV rays, but because they form a thin film, they can be prone to peeling under certain conditions.

For new wood decks, particularly redwood or cedar, you should apply a finish immediately. For "wet" pressure-treated lumber, you should apply clear finish as soon as the wood has dried out. If you're applying a stain to new pressure-treated wood, it's best to let the wood weather for two or three months so the stain will absorb properly.

Generally, you can expect clear waterproof preservatives to last about one year. Stains will last from two to four years.





AFTER

Deck Rail Redo

A new railing and built-in lighting complete our deck transformation.

Compare the two photos on this page and you may find it hard to believe it's the same deck. Despite its weathered appearance, this deck was basically sound. It just had a few problems.

First, the railing was the generic version of plain (see photo below). In fact the entire deck was a typical no-frills design, evidence that the builder chose to spend most of the budget elsewhere.

A bigger problem was the stairs. Centered on one side, they did a poor job of directing traffic flow from the back yard to the house.

The narrow width of the stairs seemed to close off the deck from the yard. Overgrown plantings added to this feeling of isolation.

Finally, the only lighting was an overhead spotlight on the house that blinded guests and attracted bugs.

MAKE A CLEAN START

The first step in reviving the deck was tearing off the railing and cleaning up the deck (see the previous article).

During the demolition, I decided the old shrubs had to go too. They were badly overgrown anyway and always in the way. If you have the same problem, but want to save them, consider temporarily transplanting them to a safe location.

With the railing off and the site cleaned up, you get a clearer picture of what you've got to work with. I spent some time looking at the deck and the house before moving ahead.



BEFORE

DECK ASSEMBLY

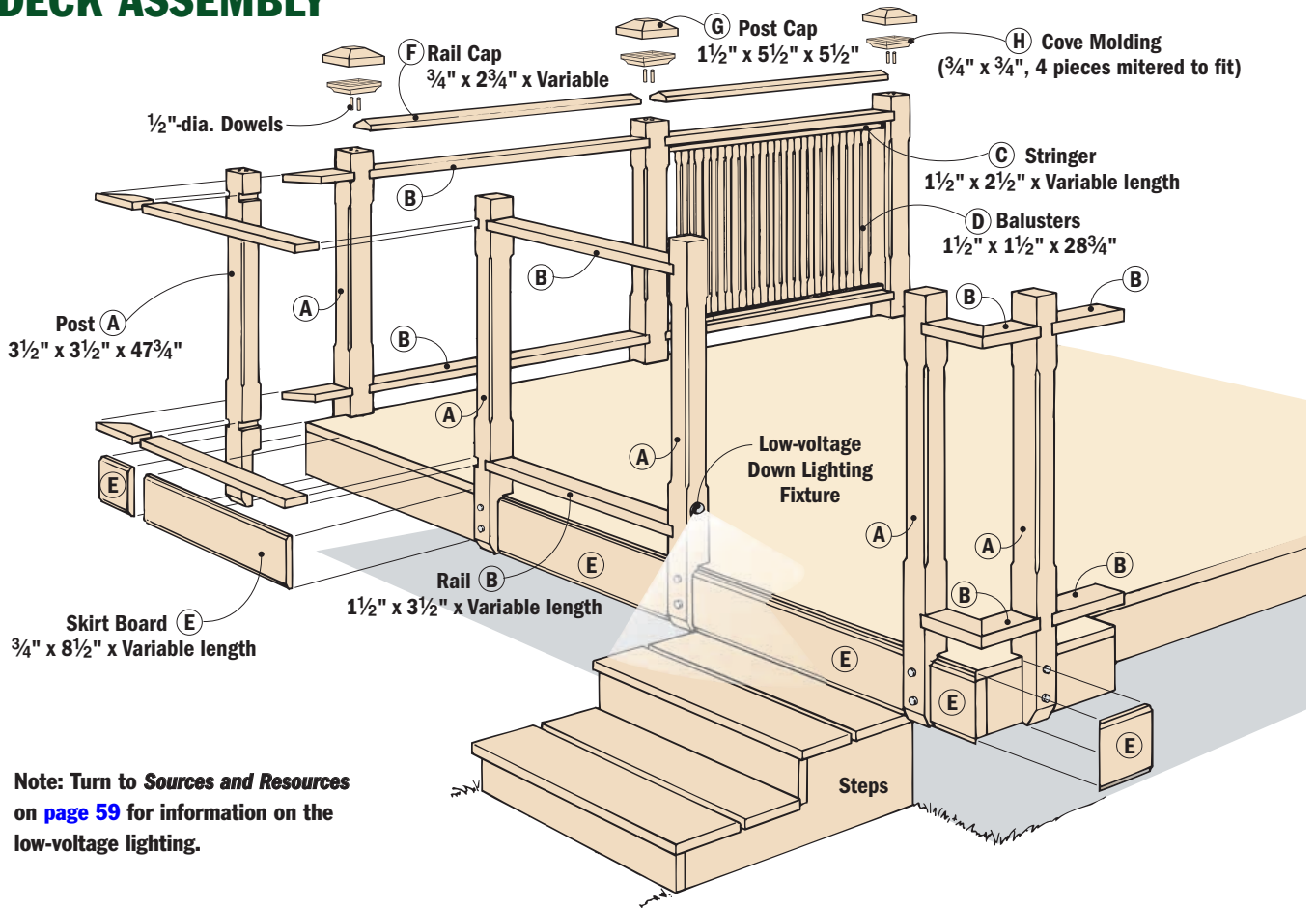

Note: Turn to **Sources and Resources** on **page 59** for information on the **low-voltage lighting**.

STYLISH NEW RAILING

Deciding that the railing had to go was easy. Coming up with a replacement took a little more work.

Made from cedar, the new railing has much stronger horizontal lines and shorter balusters. This gives the deck a more open feeling.

It also has lots of small design touches, such as stopped covers on the posts (A) and balusters (D). The beveled stringers (C) and rail caps (F) shed water.

And I came up with a unique solution for adding lights while keeping the wiring hidden. (Take a look at the cover to see how inviting this subtle lighting makes the deck look.)

To address the problem with the stairs, note how I shifted them to the right end of the deck near a sliding glass patio door. This kept most of the traffic down at that end, and created a larger, open area that had room for a table and chairs, as well as a spot for the barbecue grill.

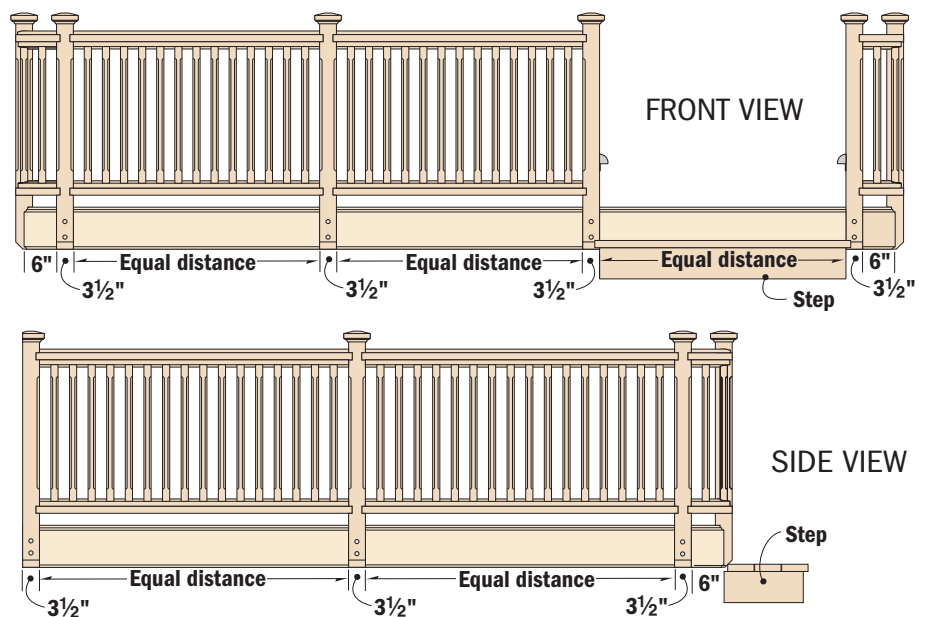

The new stairs are also wider, adding to the deck's more open feel. If you look at the Front View above, you'll see that the stairs are almost one-third of the deck's length.

To calculate the post placement to achieve this equal spacing, I first sub-

tracted 6" off each end (as shown), as well as the combined width of the four posts ($4 \times 3\frac{1}{2}" = 14"$). Then I divided the remaining distance by three. For the side, I used the same approach, but divided this shorter distance in half (instead of thirds).

POST ORIENTATIONS

NOTE: All dados are 1½"-wide x ¾" - deep

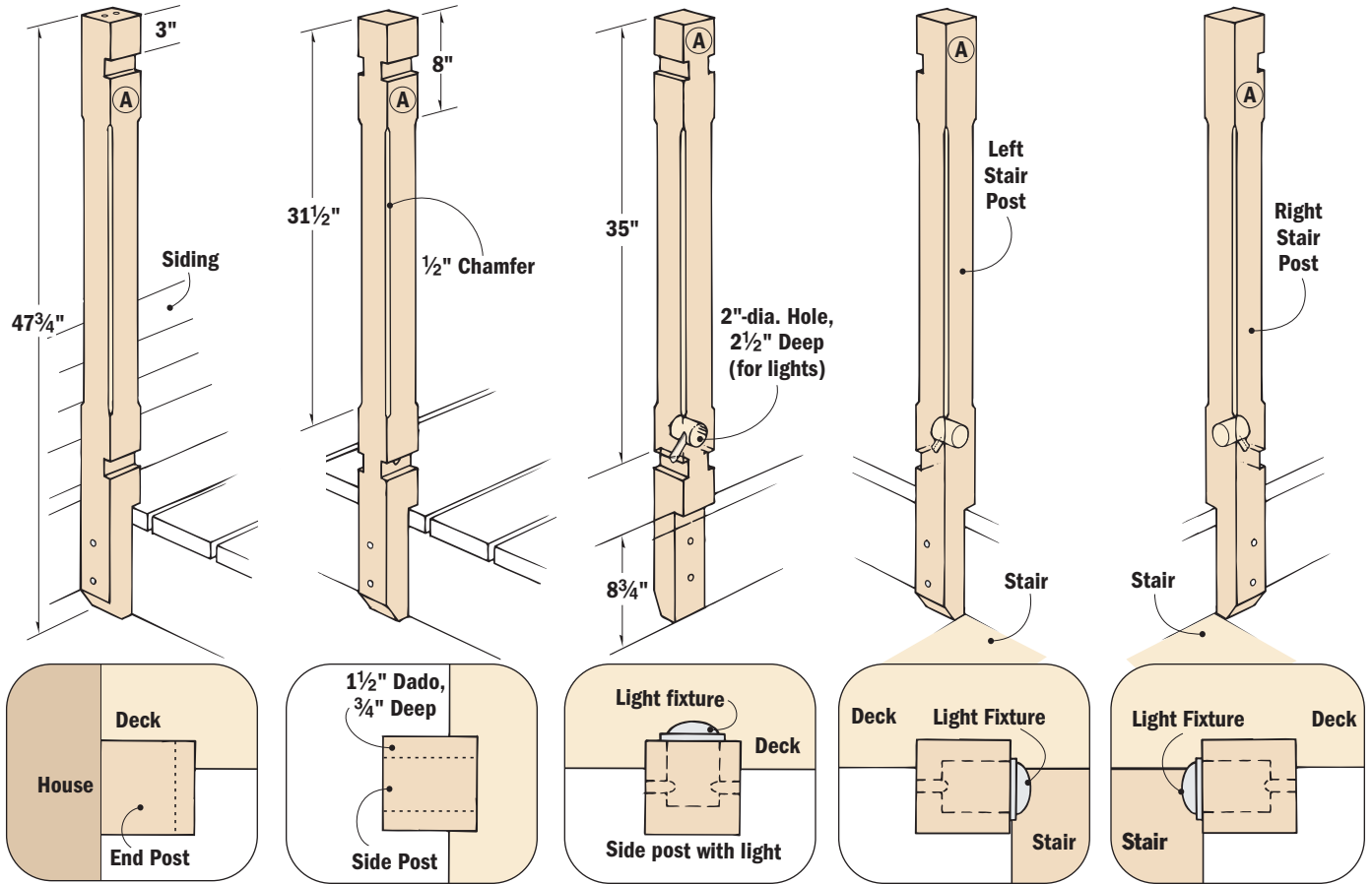

MAP OUT POST ORIENTATION

At a glance, the deck posts (A) may all look the same. They're notched at the bottom where they mount to the deck. And they've got dados that accept the top and bottom rails.

But take a closer look at the drawings above and you'll see each one is slightly different. Some join the house, others fit between two rails, and some have rails on just one side.

So it's vital that you first map out the posts you need. Clearly label each one and where it goes on a sketch of the deck. Layout the joints and mark out the waste areas with an "X".

If you plan to install lights like I did, you'll also need to mark which posts will receive light fixtures and indicate which side of the post gets the light. (You'll drill holes for the lights and wiring in a later step.)

CONSISTENCY COUNTS

Once the dados and notches have been marked on all the posts, you can start making the cuts. I used my table saw equipped with a dado blade and made the cuts in multiple passes. An auxiliary fence on your miter gauge is a big help for supporting such large workpieces (Fig. 1).

To keep the cuts uniform from one post to the next, I made the same cut (such as the notch) on all the posts and used the rip fence as a stop. Then I reset the fence, lowered the blade (to ¾") and made the upper rail dado cuts (Fig. 2).

Note: Using a dado blade, particularly on the notches, does produce a huge amount of sawdust. If you have a band saw, it's quicker and much "cleaner" to use it to cut the notches.

Another option is to make a series of cuts with a portable circular saw and clean out the waste with a chisel.

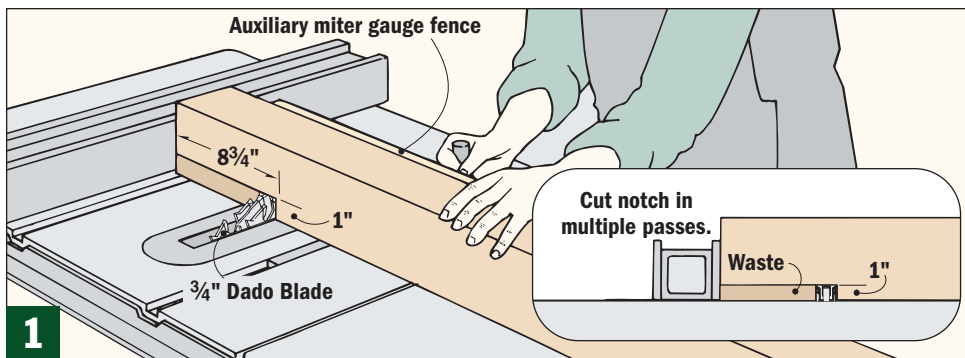

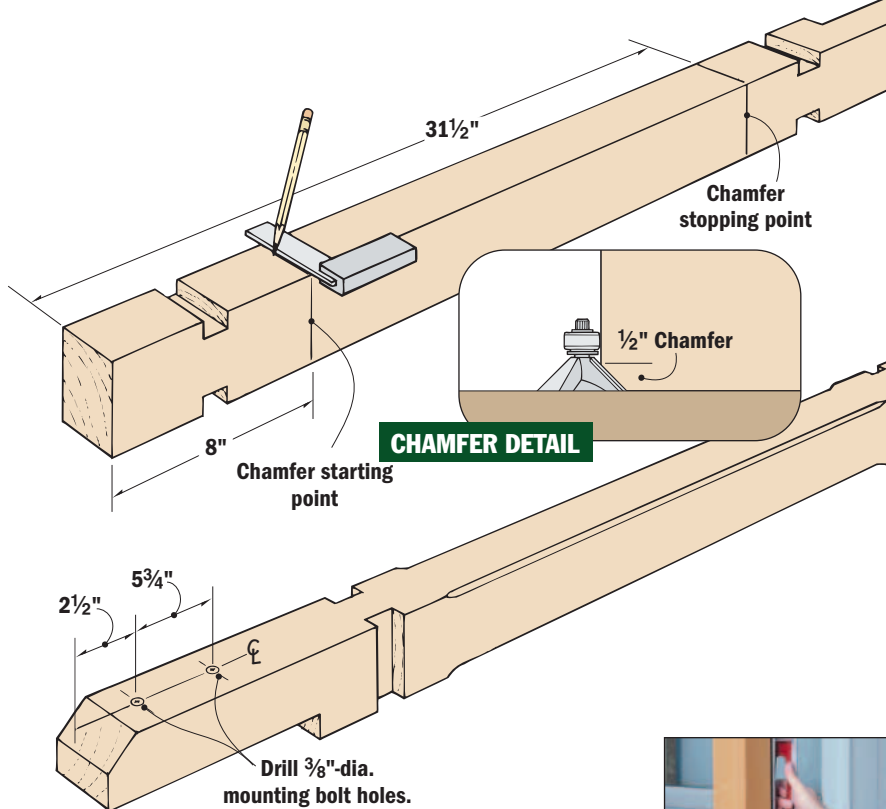
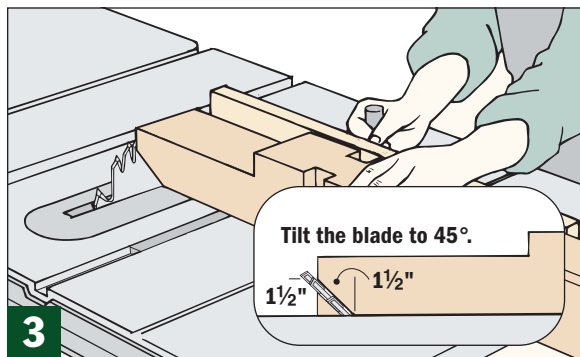
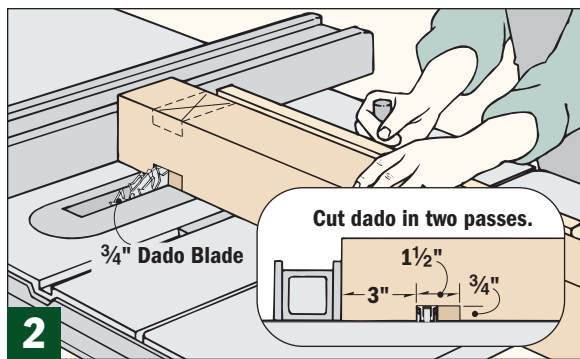

ADD THE DETAILS

The bottom end of each post gets a decorative miter opposite the notch. I tilted my table saw blade to 45° to make these cuts (Fig. 3).

Another detail that dresses up the posts and balusters is a stopped chamfer on each corner. As you can see in the *Chamfer Detail*, I started by marking the starting and stopping points for the chamfers on all four sides of the posts.

Since the posts provide plenty of surface area to support the router, I

routed the chamfers with a hand-held router. (Find out more about routing stopped cuts by turning to *In The Shop* on [page 15](#)).

DRILL THE MOUNTING HOLES

Unless you simply can't access the underside of the deck, I'd recommend mounting the posts to the deck with carriage bolts. Lag screws just won't hold the posts tight to the deck in the long run.

Drill the holes for mounting bolts as shown above. Since the

notch will be hidden, you don't need to worry about using a backer board to prevent chipout.

If you plan to install lights, now is the time to drill the holes for those (for details see the [next page](#)).

I applied semi-transparent stain (Behr's No. 6 Natural Cedartone Oil Stain) to the posts (and the other parts, too) prior to installation. It was easier and you can seal up all the surfaces, particularly on the notches and dadoes. In fact I bought a wallpapering tray and "dipped" the balusters.



Plumb the post first, then drill mounting bolt holes in the rim joist.

MOUNTING THE POSTS

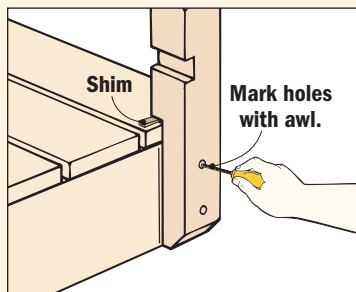

If necessary, use shims to get the posts plumb. Mark along both edges and the bolt hole locations.

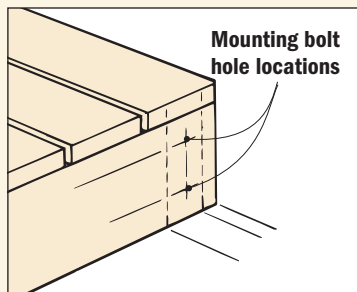

With the bolt hole locations marked, remove the post and drill the holes in the rim joist.

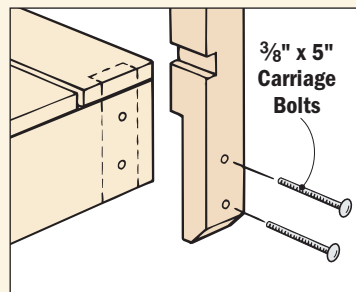

Reposition the post on the deck and bolt it using 3/8" carriage bolts with washers and nuts behind the joist.

RAIL ASSEMBLY

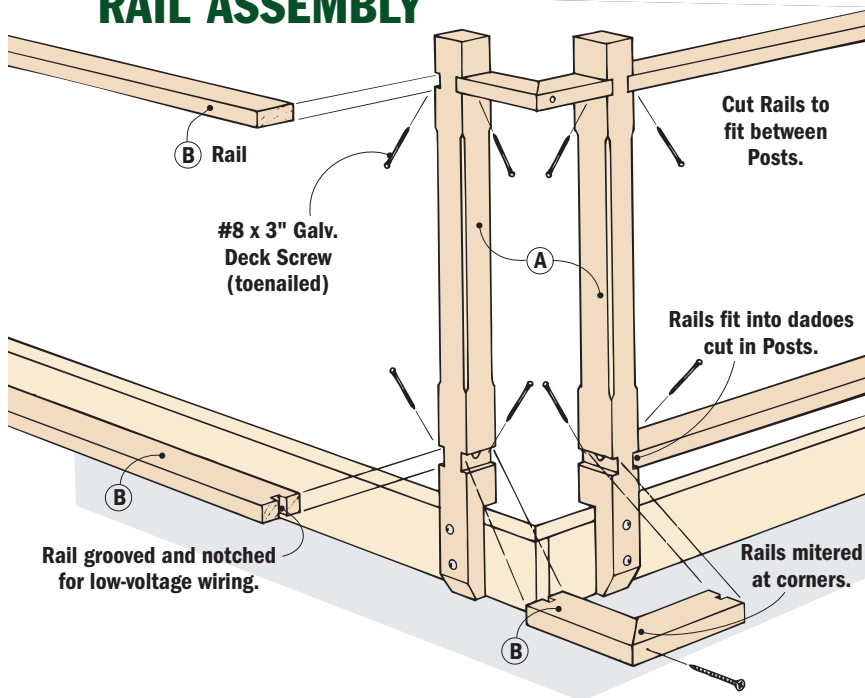

FIT THE RAILS

Once the posts are in place, the top and bottom rails (B) are added. The rails tie the posts together and support the baluster sections that will be assembled in the next step.

In the previous step, you carefully plumbed the posts so it's important to cut the rails to fit precisely. Cut them too long or short and you can move the posts out of plumb.

If you plan to install lighting, you'll need to prepare the bottom rails as detailed below. Otherwise, fit

the rails in place and drive galvanized deck screws as shown above.

The corners get rails too, but it takes a couple of steps. Start by temporarily installing a piece of rail in one post and mark the rail for length (Fig. 4). Miter this piece, then cut the second one to mate with the first one. (You may want to match the miter first, then trim the piece to length on its square end.)

Finally clamp the mitered ends of the rails together and drive screws to hold the pieces together (Fig. 5).



Fit a length of rail into one post. Holding a square against the other post, mark the inside edge of the miter.



With the rails mitered and cut to length, clamp the mitered ends flush and screw them together.

BUILD THE BALUSTER SECTIONS

This railing is easy to build because the balusters (D) are first mounted between the stringers (C) in sections. These sections are then fitted into place between the rails.

THE HOLE STORY ON LIGHTING UP THIS DECK

The trouble with outdoor lighting is hiding (and protecting) the wiring. For this project, I tucked the wiring into a groove in the bottom rail and ran it *through* the posts. As shown in the drawing below, you start by drilling a 2"-dia. hole, 2½" deep

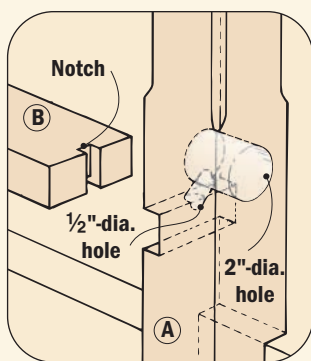

Cut a ½"-wide groove in the underside of the bottom rail. Then notch out the end.

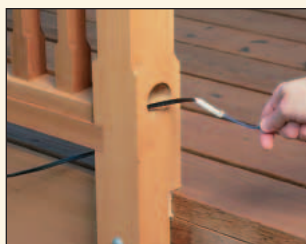

Feed the wire up through the rail and angled hole and out of the post.

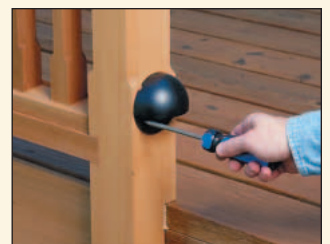

The 2"-dia. hole leaves room to tuck the wiring when you attach the light fixtures.

A bonus of this design is that the heads of the screws holding the balusters to the stringers are hidden by top and bottom rails.

As mentioned earlier, the stringers (C) are beveled so water will drain off. A small lip on the inside face also indexes the balusters and helps keep them from twisting.

Rip the stringers to width from 2x4 stock, then cut a 1/4"-deep kerf 1/2" in from one edge (Fig. a at right). Now, turn the stock on edge and tilt the saw blade 7°. Move the rip fence and raise the blade so the blade just intersects the first kerf (Fig. b).

With the stringers cut, you can turn your attention to the balusters (D). The ends of each baluster are mitered to match the bevel you just cut on the stringers.

There's also a stopped chamfer on each of the corners. Because the balusters are narrow and there are so many of them, I routed these with a table-mounted router (see page 15 for more on this technique.)

So how do you figure how many balusters to make and how far apart to space them? Most building codes require that balusters be spaced so a 4"-dia. ball can't pass between them (check with your local building officials before proceeding).

I wanted a narrower spacing than that. So I chose a 2 1/2" spacing as a starting point.

By dividing the length of a stringer (51 3/8") by the combined width of a baluster and a space (1 1/2" + 2" = 4"), it gave me the

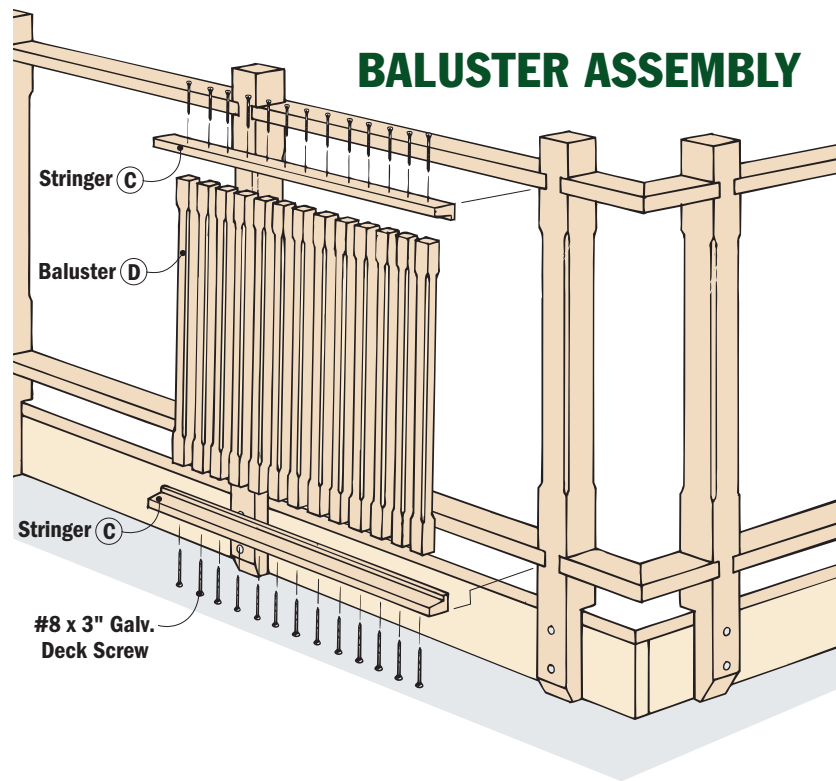

BALUSTER ASSEMBLY

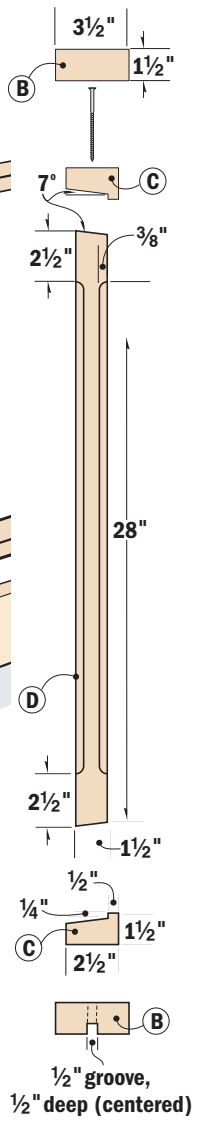

rough number of balusters (which rounded up was 13).

To get the exact spacing, I multiplied the baluster width by the number of balusters (1 1/2" x 13 = 19 1/2"). The stringer length minus the total baluster width gave me what was left for spaces (51 3/8" - 19 1/2" = 31 7/8"). Since there's one more space than balusters, I divided 31 7/8" by 14 to get a spacing of 2 1/4".

To assemble the sections I set up the stringers so the balusters could rest on the lip. A 2 1/4"-wide spacer helped install them (Fig. 6). The assembled section was then moved into position and nailed into place (Figs. 7 and 8).

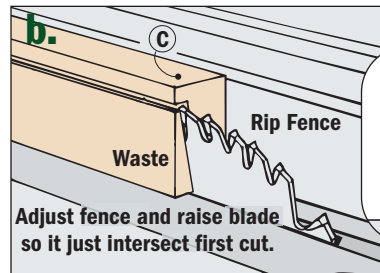
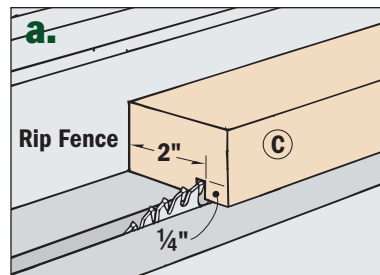

6 Starting at one end, use a spacer to position the balusters. Then attach them to the stringers with 3" screws.



7 With the baluster section assembled, slide it into place. Put the stringer's "lip" toward the interior of the deck.



8 Center the stringers on the width of the rails. Drive 6d galvanized finish nails to hold the sections in place.

CORNER BALUSTERS

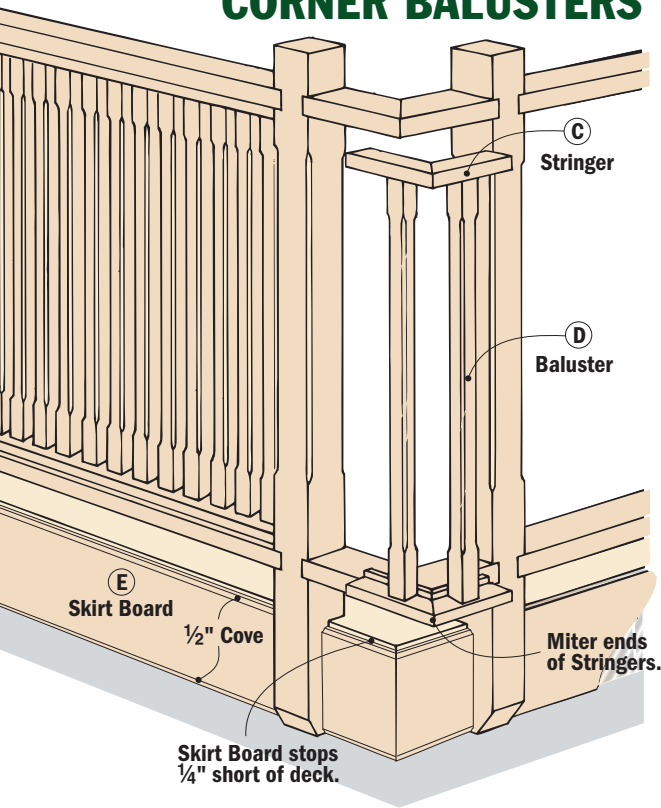

FILL IN THE CORNERS

One thing I tried to do with this deck design was beef up the corners without using big, heavy corner posts. Instead, I used two standard-sized posts and moved them 6" away from the actual corner of the deck.

These open corner spaces get baluster sections, too. Similar to the rest of the railing, the corners are preassembled and slid into place as a section (see drawing above).

Start by mitering stringers to length like you did earlier for the



Miter one piece of stringer to match bottom rail. Then position a second piece and mark it to match the first.



Glue and screw the mitered stringer pieces together. Then attach the balusters and install the corner section.

corner rail pieces (Fig. 10). After gluing and screwing the stringers together, I added the balusters, centering them on the length of the stringer lip (Fig. 11).

The completed assembly then gets nailed in place.

SKIRT BOARD COVER UP

To finish off the lower portion of the deck, I added a $\frac{3}{4}$ " \times $8\frac{1}{4}$ " skirt board (E). The skirt is wide enough to cover the rim joists and all but a $\frac{1}{4}$ " of the decking (drawing at left).

Rather than leave the edges square, I routed a $\frac{1}{2}$ " cove along both edges. This created a "softer" transition and also made the outer edge less prone to splintering.

To install the skirt board, it's important to trim it to fit between each pair of posts. (When you plumbed the posts, they may not have been perpendicular to the sur-

face of the deck.) Also, if you shimmed the posts to get them plumb, fitting the skirt board snugly against the posts will help hide any gaps caused by the shims.

The skirt boards get face-nailed to the joists and are mitered and glued at the corners (Fig. 12).

RAIL CAPS COME NEXT

All that remains at this point is to add the finishing touches. The first of these is a rail cap (F). It's nothing more than a piece of 1x stock that has a pair of matching bevels cut on the top surface (Fig. a below).

The resulting shape is similar to a small roof, and it helps shed water from the otherwise flat upper rails. To install it, the cap rail is cut to fit between the posts.

Like the other rail pieces, the rail caps are mitered at the corners. All of the rail caps get nailed in place.

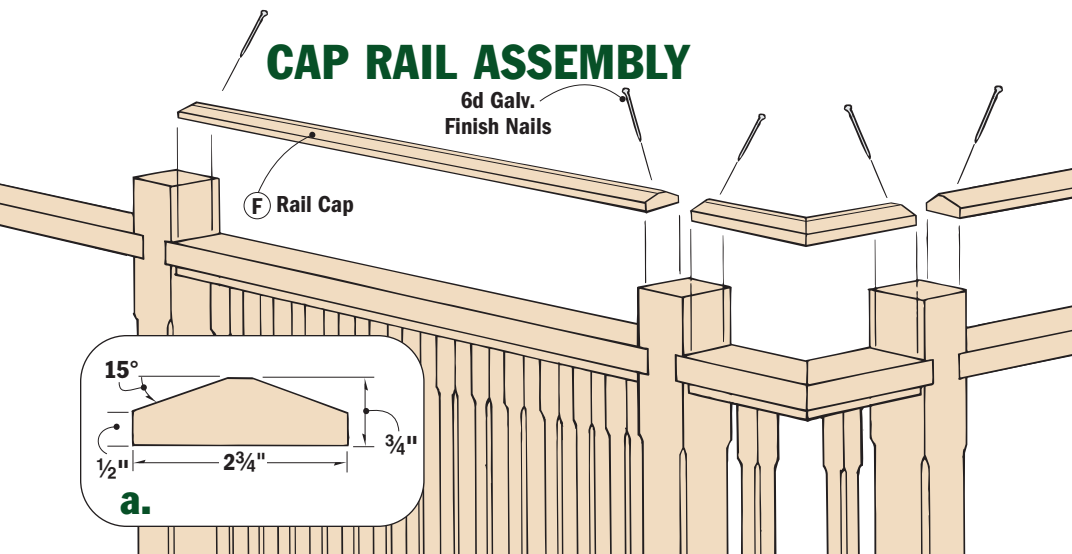

The ends of the skirt boards (E) are mitered to length in the corners. Glue the mitered edges and face-nail the skirts in place.



13

Position the drilling jig on top of the post and use the guide holes to drill holes for the 1/2"-dia. dowels.



14

Fit the jig on the post cap and drill the dowel holes in the cap. A piece of masking tape can serve as a depth stop.

POP A CAP ON THE POSTS

Topping off the posts is the final construction step. The post caps (G) are cut from 2x6 stock with the top edges beveled similar to the rail cap. Besides dressing up the posts, the caps help keep water from collecting on the posts.

If possible, use the straightest, tightest grained cedar you can find for the caps. Even then, I guarantee that some of them will warp and cup. You may want to make a few extra while you're at it so you can replace those that cup too much.

To make the post caps, start with 5 1/2" square blocks of 2x cedar stock. To safely cut these small pieces on the table saw, see the technique we used on page 47. Tilt your table saw blade 15° and adjust the rip fence to 1" away from the blade.

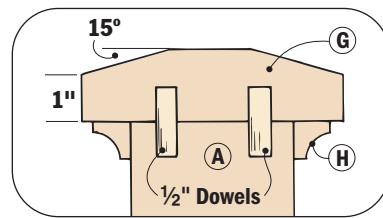

MOUNTING THE CAPS

I wanted to attach the caps firmly to the posts, but didn't want fasteners showing. So I decided to use dowels to hold the caps in place.

Anytime you use dowels, the mating holes have to line up perfectly. To do this, I built the simple, two-sided drilling jig detailed below. One side of the jig fits over the end of the posts (Fig. 13). The jig's other side slips over the post cap (Fig. 14).

To ease the transition between the post and the cap, I added a cove

molding (H) under the cap (above). Attaching the cove is the perfect time to use an air-powered brad nailer if you have one. Otherwise, you may want to drill pilot holes to keep the finish nails from splitting the cedar molding.

Since all the parts had been stained prior to installation, the deck was finished when the last piece of cove was in place. Even the "hidden" surfaces got finish, meaning I'll spend more time enjoying the "new" deck and less time maintaining it.

POST CAP AND COVE

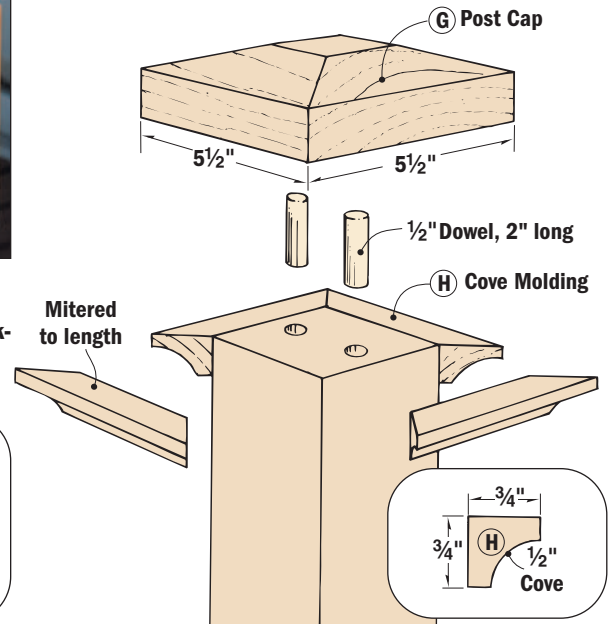

POST CAP MOUNTING JIG

One set of holes is the key to this simple drilling jig. You use the same holes to drill dowel holes in both the post and the cap.

Start by cutting a plywood square the same size as the cap, then drill the holes where shown in the detail drawing.

Hardboard edging helps "index" the cap while drilling. To index the jig to the post, the bottom side of the jig has 1"-wide pieces of hardboard butted against the edging and glued around its perimeter.

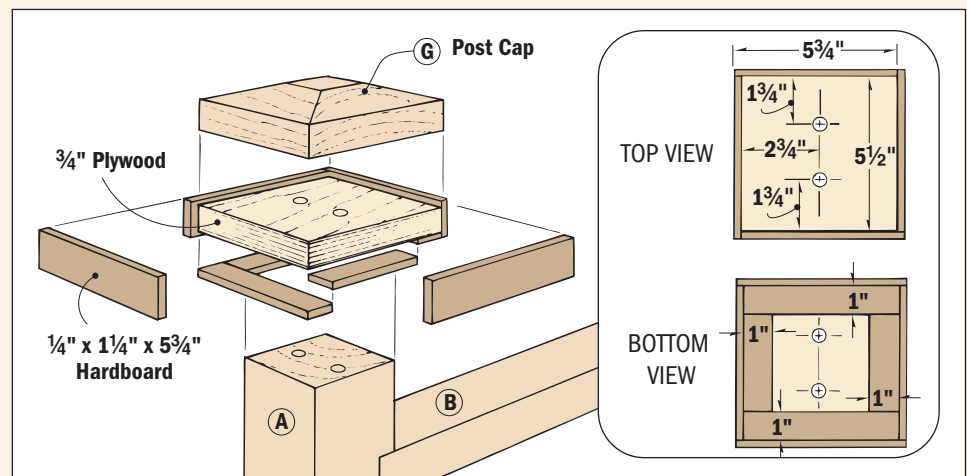

Plunge Routers

In today's super-size world, these midsize routers make a strong case for being average.

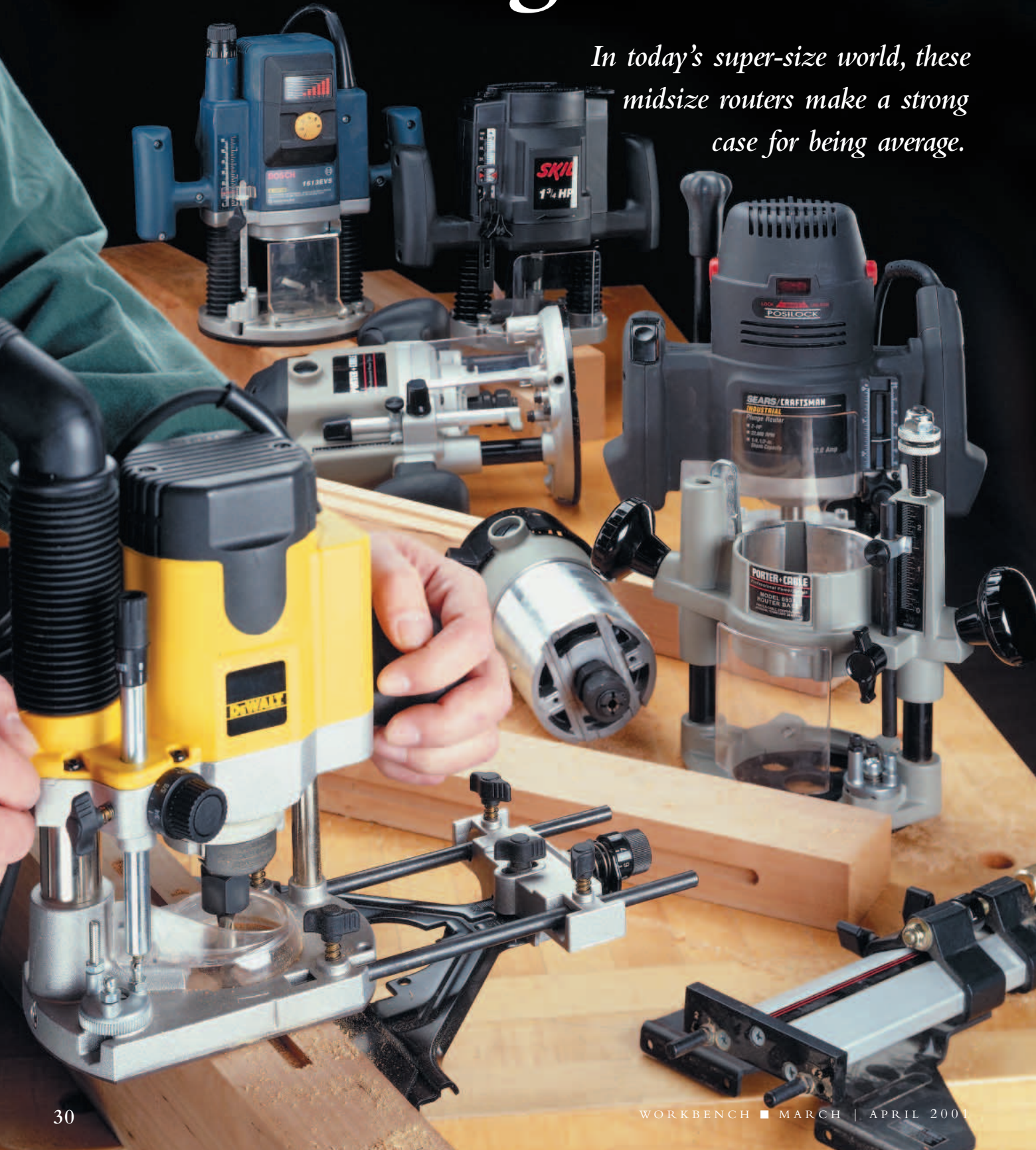

Shopping for a router requires self-discipline. It's too easy to get pulled in by the big, high-horsepower machines and their promises of shaper-like performance.

But for most projects, a midsize plunge router — in the 1½ to 2 HP range — fits the bill. They're relatively light and ideally suited for handheld operation. And the plunge action gives you more flexibility, particularly on stopped cuts such as mortises.

While that narrows the field considerably, there are still lots of routers to choose from. So I gathered up some of the most popular models, recruited a few guys from the *Workbench* staff, and headed for the shop to do some testing.

As we hashed out the merits and weaknesses of each router at the end of the day, some common threads began to emerge. Everyone agreed that for a plunge router to be accu-

rate, the plunge action needs to be clean — no side-to-side movement. From there, the key features were the collets, switches, plunge locks, stop turrets, and fine adjustments.

Collets: Grab a chunk of hardened steel and spin it at 23,000 rpm. Now plunge it up and down in a piece of hardwood and move it side-ways to cut a groove. Oh, and by the way, don't let it slip even the slightest bit. If it moves even a fraction of an inch, your work is ruined. That's what a collet does — or, that's what it's supposed to do. Some are better built for it than others.

Another collet-related issue we were concerned about was how easy it was to change bits. That's largely determined by whether a router has a spindle lock or not.

Switches: You've got enough to think about when using a router — turning it on should be simple. And once it's turned on, locking the trig-

ger should be just as easy. We were amazed at how complicated some of the triggers were. Some of the best routers had the worst switches.

Plunge Locks: These should be as simple as the On/Off switch.

The best locks are easy to reach and activate and spring back when you let go of them.

Stop Turrets: I wouldn't have believed there was going to be a lot of difference in these. All a turret does is make it easy to divide a cut into numerous passes. A three-position turret is a minimum — it takes at least that to safely make a cut ½" deep or more.

Fine Adjustments: Even the best turret is worthless if you can't set the depth of cut accurately in the first place. This is where all but one router suffered.

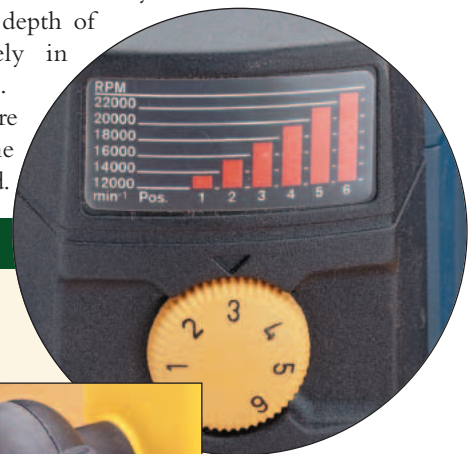

DETAILS THAT MAKE A DIFFERENCE

The devil is in the details and these half dozen routers were devilishly different on a number of counts.

Here's a snapshot of what we liked and what we disliked.

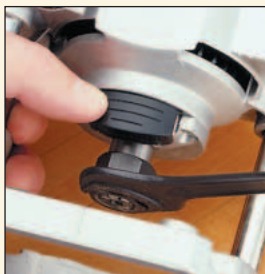

BIT CHANGING DeWalt's spindle lock was the best. The PC 693's two-wrench system needs to be retired.



ON/OFF SWITCH Porter Cable's 7529 has a rocker switch for table use. DeWalt's switch is too involved.

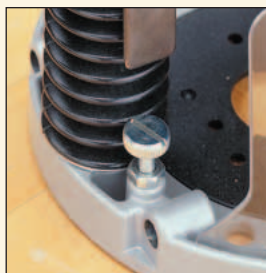

TURRET STYLE Porter Cable's 693 had the most versatile turret. Skil's single-position design is poor.

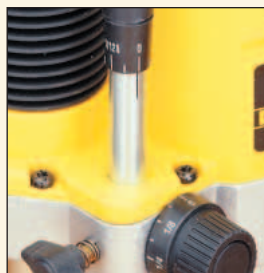

DEPTH ADJUSTMENT The DeWalt system is flawless. Skil's depth adjustment is more of a "guestimate."

Bosch has the best example of a variable speed control with the speed ranges printed right above the switch. Half the routers we looked at didn't have variable speed control.



DEWALT DW621



Plunging action is all-important, and on that score, the DeWalt DW621 was the hands down winner.

The depth adjustment system on the DeWalt was also the best in the field. It's accurate and relatively easy to use.

The 621's lightweight, nimble feel, and dual straight-edged base makes this the most user-friendly model we tested.

Where this router suffered was in the details. For instance, the plunge lock required too much twisting to make it work. And the turret was weak, too. It only has three positions, and it didn't seem to line up easily with the stop rod. Finally, the push-pull-push action of the trigger lock was tricky.

Still, this was the best router in the test. And the price is unmatched in relation to quality.

At A Glance:

Price: \$199
Motor: 2hp (10 amp)
Speed: 8 – 24,000 RPM
Collets: 1/4", 1/2"
Warranty: 1 year

Virtues: Depth adjustment; dust extraction; plunge action.
Vices: Trigger lock; plunge lock; turret.
Verdict: Requires some dexterity to operate, but still the best router here.



PORTER-CABLE 7529



The Porter-Cable 7529 missed first place because of a few shortcomings.

But overall, Porter-Cable did things right on this router.

The fit and finish is the best in the group. And the plunge lock is nearly perfect. It's easy to reach, requires a light touch, and springs back for a

positive lock. Using this router is also a pleasure thanks to its quiet, smooth motor.

Now the shortcomings. The trigger lock is too complicated. The depth stop rod is hard to use. And the spindle lock bites into your thumb when you depress it.

One tester did complain about slop in the plunge.

All things considered, the 7529 could easily have been number one, had it not been for those few details.

At A Glance:

Price: \$205
Motor: 2hp (12 amp)
Speed: 10 – 23,000 RPM
Collets: 1/4", 1/2"
Warranty: 1 year

Virtues: Fit and finish; two switches; plunge lock.
Vices: Turret; depth adjustment; trigger lock.
Verdict: With a few refinements, this router would have taken the number one spot.



BOSCH 1613EVs



The Bosch 1613 falls in the middle of the pack and represents what an average router ought to be: Competitive price, good power, some good features, and a few things that aren't so good.

The no-nonsense trigger and lock are refreshingly simple. The same goes for the eight-position turret.

On the downside,

the plunge lock can't be reached with your hand in the operating position. And mounted above that really nice turret is a grossly sloppy depth adjustment. Another annoyance is the plastic-coated cord. It's stiff and inevitably in the way.

Overall the 1613 isn't too bad, but it's not real good either. And at just \$10 less than the top-ranked router, we expected more than an "okay" tool.

At A Glance:

Price: \$189
Motor: 2hp (11 amp)
Speed: 10 – 23,000 RPM
Collets: 1/4", 1/2", 3/8"
Warranty: 1 year

Virtues: Trigger lock; idiot-proof turret; flip-down dust shield.
Vices: Plunge lock; depth adjustment.
Verdict: Not enough reasons to buy this router for this price.



PORTER-CABLE 693

At A Glance:

Price: \$179
Motor: 1½hp (10 amp)
Speed: 23,000 RPM
Collets: ¼", ½"
Warranty: 1 year

Virtues: Two bases; turret; depth adjustment.
Vices: Single speed; no spindle lock; coarse plunge action.
Verdict: Still the best dollar-for-dollar value in routers, period.

It's important to understand that we had to rate these tools based solely on their merits as plunge routers. And as a hybrid tool, the 693 had to have some compromises.

The compromises were enough to knock the 693 out of the top spots.

The lack of a soft start and variable speed control bothered us. We also missed having a switch in the handle.

The plunge action was rough, too, and tended to

catch on the way back up.

In its favor, the 693 does have the nicest turret in the field. It also had an accurate, easy-to-use depth adjustment.

And even though the 693 took a few lumps in this test, there isn't a better deal to be found if you want a fixed base *and* a plunge router.



CRAFTSMAN 27510

At A Glance:

Price: \$199
Motor: 2hp (12 amp)
Speed: 22,000 RPM
Collets: ¼", ½"
Warranty: 1 year

Virtues: Hands-free spindle lock; smooth plunge.
Vices: Single speed; collets; depth adjustment.
Verdict: For this price, you can buy so much more router than Craftsman offers.

The Craftsman 27510 is huge. So why didn't they use all that space to house a few more goodies?

One nice feature is the spindle lock. Once you lock it, you can devote both hands to changing the bit. And as for performance, the router rides up and down the plunge rods with hardly any play at all. Unfortunately, it's all downhill from there.

The collets are horrible. They're held onto the spindle

with a screw, which is bound to strip. Then you're stuck with whichever collet is in the machine at the time.

Another bad idea is the trigger lock. It practically requires three hands. Lastly, the depth adjustment was all over the place when we tried to set it up.

And this router costs the same as the DeWalt? No thanks.



SKIL 1840

At A Glance:

Price: \$84
Motor: 1¾hp (9 amp)
Speed: 25,000 RPM
Collet: ¼"
Warranty: 2 year

Virtues: Low price; two-year warranty.
Vices: ¼" collet only; poor overall quality.
Verdict: Doesn't compare to the top models, but doesn't cost nearly as much either.

No turret, horrible depth setting, the plunge lock has no return spring...the list of things that the Skil doesn't have goes on and on.

But consider this: The Skil can cost one-third what some of the routers in this test go for. So lower your expectations by 67%, and you'll find that this machine meets those expectations. After all, could DeWalt or Porter-Cable offer anything better than this for under \$100?

In short, this is not the router for a serious woodworker. But for someone getting started on a shoestring budget, this would be a fine place to start. And when the time comes to trade up to one of the big dogs, you'll know which features matter to you.

Frankly, I'd sooner pay \$80 for this router than \$200 for the Craftsman.



FEATURES & QUALITY

All tools were rated as follows:
E = Excellent
G = Good
F = Fair
P = Poor



	DeWalt DW621	Porter-Cable 7529	Bosch 1613 EVS	Porter-Cable 693	Craftsman 27510	Skil 1840
Depth Adjust.	E	F	F	G	F	P
Plunge Lock	G	E	P	G	F	P
Trigger Lock	F	F	E	N/A	G	F
Plunge Action	E	E	F	F	G	F
Bit Changing	E	G	G	P	E	G
Collet Quality	E	E	G	G	P	F
Fit/Finish	E	E	F	E	F	F

FINAL RECOMMENDATIONS

De' WINNER IS...

If you can have only one router in your shop, make it the DeWalt DW621. And if you can own several routers, at least one of them should



be the 621. This router is that good. You can't beat the combination of price and performance that this tool delivers. In fact, it would be easy to spend a whole lot more and get a whole lot less.

Never mind that the unusual plunge lock and trigger operations on the 621 involve a slight learning curve. That's easy to forgive when you weigh the value of the precision depth adjustment, the unmatched dust collection system, and the flawless plunging action. And after all, every tool takes some getting used to.

RUNNER UP

As for the Porter-Cable 7529, we liked it almost as much as we liked the DeWalt. (In fact, one tester liked it even better.) We just docked it a few points for some of its design oddities. Just the same, you should seriously consider this router if you plan to use it primarily in a table. That second switch is handy for that.

ALSO RAN

It's hard to imagine any reason not to buy one of the top two routers, but if neither one seems like what you want, the remaining four offer a mixed bag of good and bad.

The Bosch is tough to recommend simply because it costs nearly as much as the DeWalt, but isn't nearly the tool.

The Porter Cable 693 doesn't score well as a pure plunge router, but for my money, there's no better value to be had. This package amounts to two routers for under \$200. Pick up a variable speed switch, and you're pretty well set.

The Craftsman, well...it costs way too much for what it delivers. At that price, I expect features and performance like the top two finishers. This router just doesn't deliver.

As for the Skil, don't expect much and you won't be disappointed. But if you need a basic router for a few bucks, this might be the answer.

Router Accessories

Turn to *Sources and Resources* on [page 59](#) to find router accessory dealers.



SPIRAL BITS -

Upcut spiral bits (left) lift the chips out of the kerf as you rout, allowing a faster feed rate than a straight bit.

Downcut spiral bits (right) push the chips down into the

kerf — which requires you to slow the feed rate down. However, it does leave a cleaner top edge on the workpiece.

EDGE GUIDE - I'd have to say that a good edge guide is probably the most valuable router accessory you can own. It makes a good alternative to mounting the router in a table and it can also help you make cuts you'd otherwise need bushings or a bearing-guided bit for. Look for durable construction, a large range of adjustability, and a micro-adjustment feature.

Most manufacturers offer guides for their routers.

There are also a few good universal models. A good edge guide will cost \$30 or more.



VARIABLE SPEED CONTROL - Matching your bit speed to your stock and cut is the surest way to get clean routs and avoid burning a workpiece.

If your router doesn't have a built-in variable speed control, you can easily upgrade it with an aftermarket system like this one. These are common items in woodworking stores and catalogs. Look for one with a three-position switch and a time-delay fuse. Expect to pay about \$40.



FOOT SWITCH - Keep both

hands on your work and turn your router on and off with a foot switch. These are perfect for table-mounted routers, and also work well with scroll saws and band saws.



AUXILIARY BASE - A wider base makes your router more stable for edge work. Chances are, you can find one to work with

bushings you already own.



BUSHINGS - Guide bushings let you use your router to follow templates, make matched or mirrored parts, and trim edges, among other things.

Be sure the set you buy is intended for use with the base of your router — they're not universal. Most home centers, hardware stores, and woodworking stores carry popular brands of bushings. They can usually be bought one at a time, but the best deals can be found on complete sets.



FINE DEPTH ADJUSTER -

These are perfect for fine tuning a router when it's mounted in a table. I wonder why they don't just put them on there in the first place?



TRAMMEL - An acrylic router tram-

mel like this one is worth a few extra dollars over the shop-made wood models. You won't need to worry about warping while this compass hangs on the wall between uses. This model allows you to rout circles from 8" to 18" in diameter.



Mastering Mortises

No mortising machine? Forget the drill press — use a plunge router for perfect mortises.

A plunge router is an ideal tool for cutting mortises. But routing perfect mortises isn't automatic. To ensure accurate results, there are several things to take into consideration.

LAYOUT

At first glance, laying out a mortise looks simple — you

need to know where to start it, where to stop it, and where it's located on the thickness of the stock.

I always lay out the *ends* of the mortise first. Use a square and be sure to mark heavy lines so you can see them when the chips start to fly.

Next, lay out the *sides* of the mortise. You can do this with a marking gauge, or by locating the center of the mortise and then measuring out both directions and drawing a line to define each side. As a final check, make sure the bit you plan to use to cut the mortise “fits” inside the layout lines.

ROUTER SETUP

Once the layout is completed, you're ready to set up the router.

Start by chucking either a straight bit or a spiral up-cut bit in the router. (For a comparison of these two bits, take a look at the box shown at left.)

The next step is to set the turret on the router so you can make a

series of progressively deeper cuts in a controlled manner. Each router has a little different system for doing this, but the principles are the same.

Start by setting the router on a flat surface (use the workpiece if it's wide enough) and then rotate the turret so its *lowest* “step” is under the stop rod as seen on the [facing page](#) (Figure a). Then plunge the router until the bit just touches the surface and lock the router in that position. Now lower the stop rod on the lowest step and “zero out” the depth adjustments.

At this point, you'll need to raise the stop rod with the gross adjustment knob until the scale indicates the depth of the mortise you want to cut (Figure b). For this example, I set the stop rod to $\frac{3}{4}$ " then locked it there.

Now turn the adjustment screws on each of the other steps on the turret (if they're adjustable) to produce progressively deeper cuts. I usually adjust them so that no cut is more than $\frac{1}{4}$ " deep (Figure c).

POSITION THE EDGE GUIDE

The next step is to adjust the position of the edge guide on the router. The easiest way I've found to do this is to use the layout lines on the workpiece.

Set the router on the workpiece with the bit centered in the mortise layout lines. Rotate the bit by hand and check that the cutting edges never go outside the lines. When you're satisfied with the position, slide the edge guide up against the



WHICH BIT?

A straight bit works okay when routing a mortise, but there are some definite advantages to using a spiral up-cut bit:

- A cutting edge extends across the tip of the bit, which allows it to “drill” into the workpiece.
- The spiral cutting edges shear the wood fibers to produce a smooth, clean cut.
- The flutes pull chips up out of the cut (toward the router) so they don't clog the mortise. This reduces heat build-up, which can damage the bit.

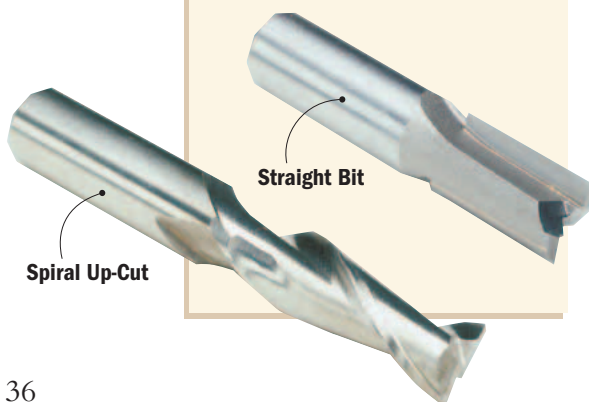

workpiece and lock it in position. Check the bit against the layout lines one last time and readjust the guide as necessary. (This is when a *micro-adjustable* guide pays off.)

One last thing, if your situation allows it, is to clamp stop blocks to the workpiece. Note: Sometimes the mortise will be too close to the end of the board and you won't have room for a stop block.

If you can use stop blocks, set them up by positioning the router at the ends of the cut. Very carefully align the bit exactly where you want the end of the mortise. Then butt the blocks against the router base and clamp them to the workpiece.

PRACTICE MAKES PERFECT

Before you start tearing into that expensive hardwood with your router, take a minute to test the setup in a scrap piece. Just keep in mind that it should be the same thickness as the actual workpiece.

After routing a test mortise, check its location. Also check the depth of the mortise and make any adjustments that are needed. Now you're ready for the real thing.

Use an auxiliary board next to the workpiece to help support the router.

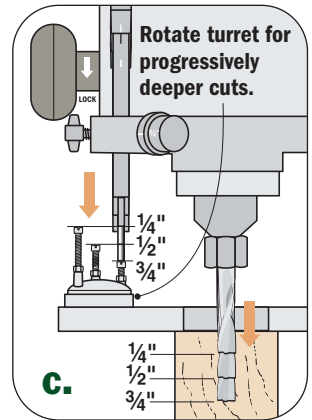
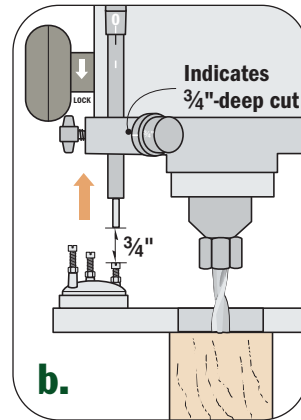
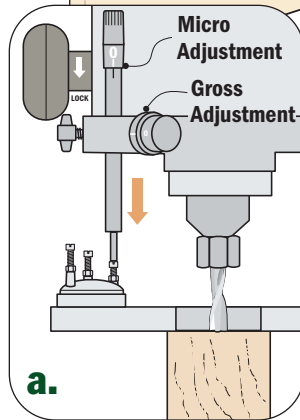
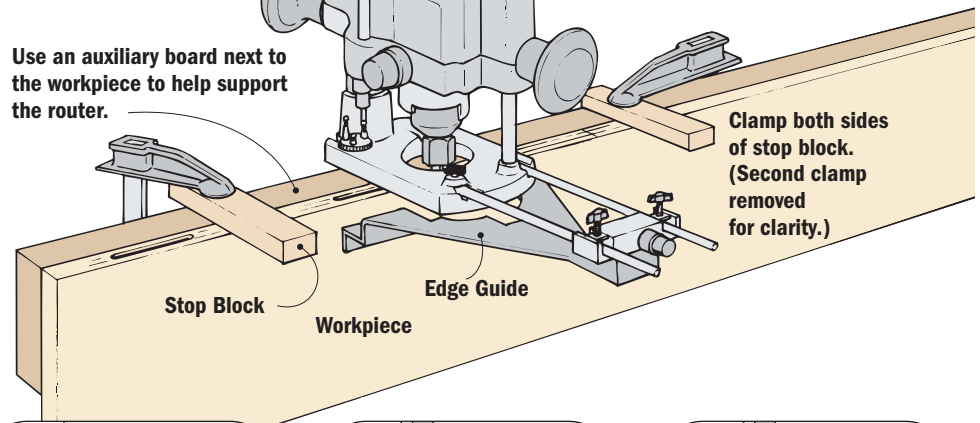

Grasp the router, set it on the workpiece, and butt the edge guide firmly against it. Then flip the switch, plunge the spinning bit into the wood until the stop rod contacts

the first step on the turret, and rout from left to right. After rotating the turret for each of the next passes, it's just a matter of repeating the process to complete the mortise. 

SELF-CENTERING MORTISING BASE

Here's a quick way to rout a mortise that's centered on the thickness of a board. Just make a base with two metal pins. Twisting the base so the pins contact each side of the board automatically centers the mortise on the thickness of the workpiece.

I made the base from a piece of 1/2"-thick hardwood that's cut in a perfect square.

The centering pins are bolts with the heads cut off. Fasten the bolts to the base with T-nuts and lock them with hex nuts from the top.

The important thing here is that the centerpoint of the bolts and the router bit form a straight line.

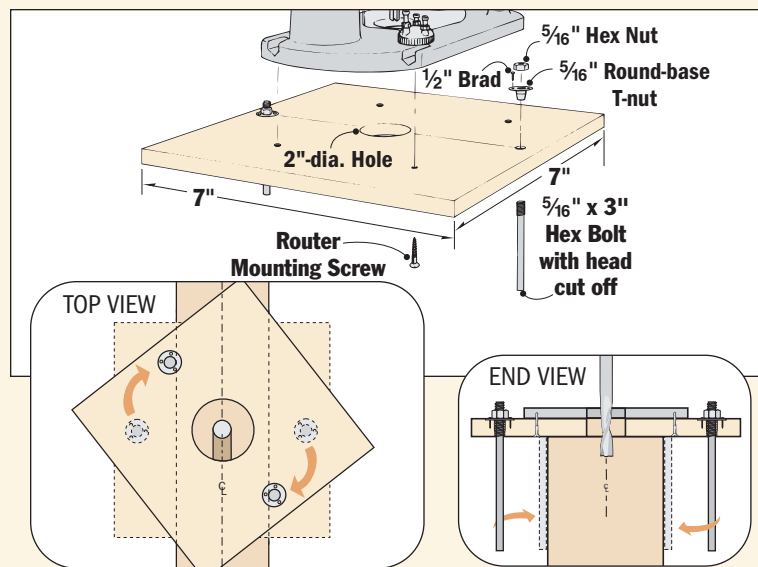



Heirloom Bed

Rest assured, this well-made cherry bed will be a family classic.

The early sketches for this Heirloom Bed sparked a lot of discussion here at *Workbench*. Everyone liked the use of cherry and the solid construction. But I also heard a few comments about how difficult it will be to build, the time it will take, and finding the materials.

“Where do you get cherry stock thick enough to make the legs?” (It’s actually two pieces glued up.) “Do you need a lathe to turn the finials?” (No, you can buy the balls pre-made.) “How do you lay out the arc on the top rails?” (It’s easy to do when you use a template.)

Once all the questions had been answered, I knew this would be a great project that a lot of people would want to build.

Now the only question is what size bed to make? We chose a queen-size, but you’ll find options on how to build a twin- or king-size version on [page 49](#).



BED CONSTRUCTION VIEW

OVERALL BED SIZE: 65¹/₄"W x 52³/₄"H x 87¹/₂"L

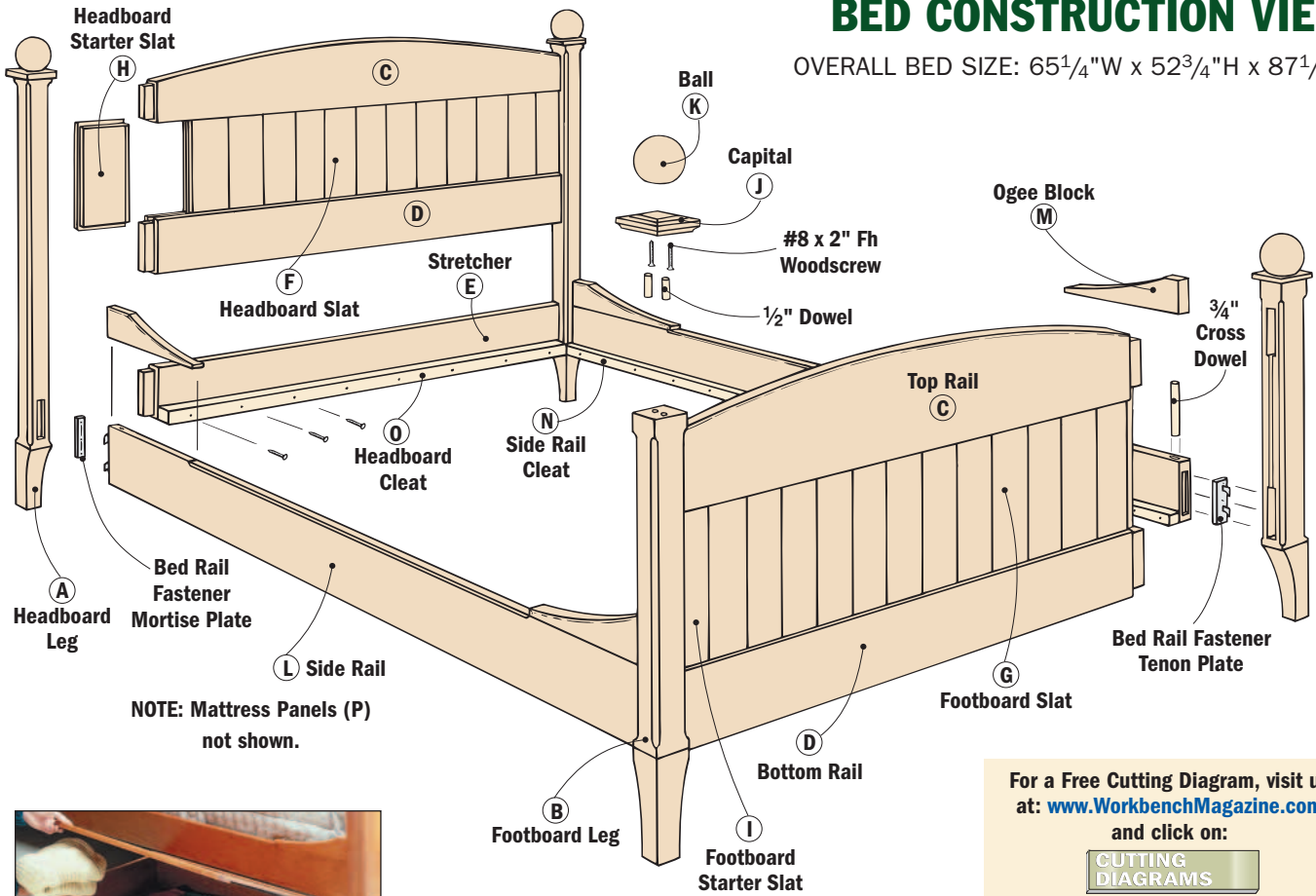

NOTE: Mattress Panels (P) not shown.



▶ Need extra storage? See page 58 for an Under-Bed Storage Box.

For a Free Cutting Diagram, visit us at: www.WorkbenchMagazine.com and click on:

CUTTING DIAGRAMS

or send a self-addressed stamped envelope to:
Workbench Magazine
2200 Grand Ave.
Des Moines, IA 50312

MATERIALS LIST

LUMBER

A (2) Headboard Legs	3" x 3" x 48" (cherry)
B (2) Footboard Legs	3" x 3" x 32" (cherry)
C (2) Top Rail	1" x 8" x 62 ¹ / ₄ " (cherry)
D (2) Bottom Rail	1" x 6" x 62 ¹ / ₄ " (cherry)
E (1) Stretcher	1" x 6" x 62 ¹ / ₄ " (cherry)
F (12) Headboard Slats	5/8" x 4 ⁷ / ₈ " x 11 ¹ / ₈ " (cherry)
G (12) Footboard Slats	5/8" x 4 ⁷ / ₈ " x 12 ³ / ₈ " (cherry)
H (1) Headboard Starter Slat	5/8" x 5 ¹ / ₄ " x 11 ¹ / ₈ " (cherry)
I (1) Footboard Starter Slat	5/8" x 5 ¹ / ₄ " x 12 ³ / ₈ " (cherry)
J (4) Capitals	1" x 4" x 4" (cherry)
K (4) Balls	4" Round Ball (Birch)
L (2) Side Rails	1" x 6" x 81 ¹ / ₂ " (cherry)
M (4) Ogee Blocks	1" x 3" x 12" (cherry)
N (2) Side Rail Cleats	1" x 1" x 81 ¹ / ₂ " (cherry)
O (2) Headboard/Footboard Cleats	1" x 1" x 59 ¹ / ₄ " (cherry)
P (2) Mattress Panels	3/4" x 41 ¹¹ / ₁₆ " - 61 ¹ / ₈ " (AC ply.)

Note: Also need 24" of 3/4" dowel and 12" of 1/2" dowel.

HARDWARE: (See pages 59-60 for information on sources.)

- (4) 5/8" x 4" Bed Rail Fasteners
- (60) #8 x 1¹/₂" Fh Woodscrews
- (8) #8 x 2" Fh Woodscrews

BUY YOUR MATTRESS FIRST

Just as you wouldn't build a picture frame and then shop for a piece of art, it doesn't make sense to build this bed frame and then buy a mattress to fit. So have your mattress on hand, just so you don't build a frame that's an inch too short. Actually, I was surprised that there aren't standards for size. I found queen-size mattresses to be anywhere from 59" to 62" wide — so measure your mattress before starting, just in case.

The measurements shown here are for the largest queen-size mattress I was able to find. But by adding a plywood platform it will hold a smaller mattress. There'll be a little room at the top and bottom of the bed to tuck in the sheets and a bedspread. The room at the sides (if you have a smaller mattress) won't be noticeable.

DESIGN OPTIONS

If you want to build the bed as a twin-size or king-size, look for dimensions and pointers on building them on page 49.

START WITH THE LEGS

Begin by building the headboard and footboard assemblies. I started by gluing up four blanks for the headboard legs (A) and footboard legs (B). Each blank is made up of two pieces of 1³/₄"-thick cherry, glued face-to-face.

As you can see in the *Leg Details* above right, I left the legs a little long. This makes it easier to attach a pair of stop blocks for routing some stopped chamfers later.

I also spent a little extra time making sure the best grain was showing on the face of each of the legs (when looking at them from

the foot-end of the bed). This also means the glue lines will be less noticeable because they're on the sides of the leg.

Now you're ready to cut the legs to finished thickness and width (3" x 3"). To do this, I used the jointer and the table saw. Start by squaring the blank, then be sure to trim equal amounts from the two face sides. The idea is to keep the glue line centered on the thickness of the leg.

MORTISES FOR THE RAILS

I used mortise and tenons to provide a strong joint between the legs and the headboard and footboard rails. Each leg has two mortises for a top and bottom rail, as shown in the *Leg Details* drawing. The headboard legs have an extra set of mortises for a stretcher. The stretcher adds strength to the taller headboard. Note: Because the legs are trimmed to length later, I marked the bottom of each leg and laid out all the mortises from that end.

Now chuck a 1/2" Forstner bit in the drill press to rough out the mortises (Fig. 1). They're slightly deeper (1 9/16") than the tenons to allow for glue squeeze-out. As shown in the photo above right, I used a sharp chisel and an edge block to square up the corners of the mortise.

GROOVES FOR THE SLATS

The slats that make up the panels in the headboard and footboard use tongue-and-groove joinery. This allows the slats to expand with changes in humidity. So a groove needs to be routed on the legs to make room for the tongues.

LEG DETAILS

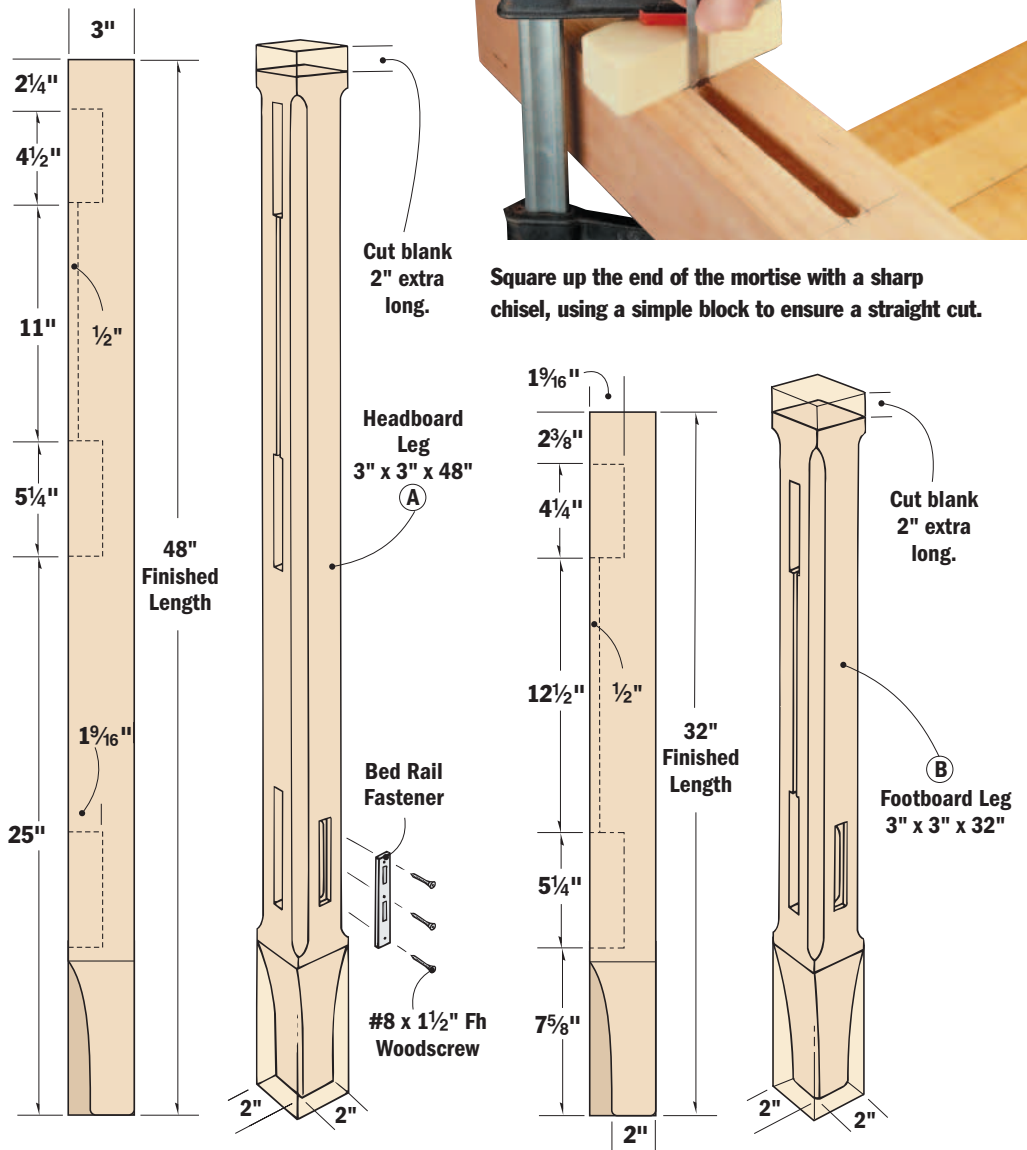

To add the groove, I used a 1/4"-straight bit and a router table. An easy method for doing this is to set the fence so that the groove will be centered on the leg and then rout from

one mortise to the next (Fig. 2a). Just set one mortise over the bit, start the router to make the cut, then rout along the fence until you reach the other mortise (Figs. 2 and 2b).

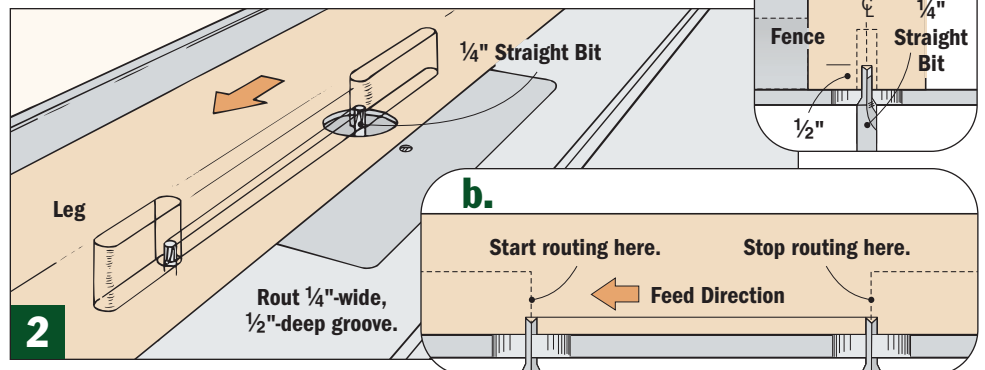
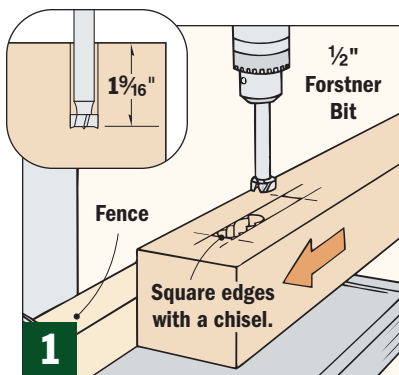

BED RAIL FASTENER ASSEMBLY

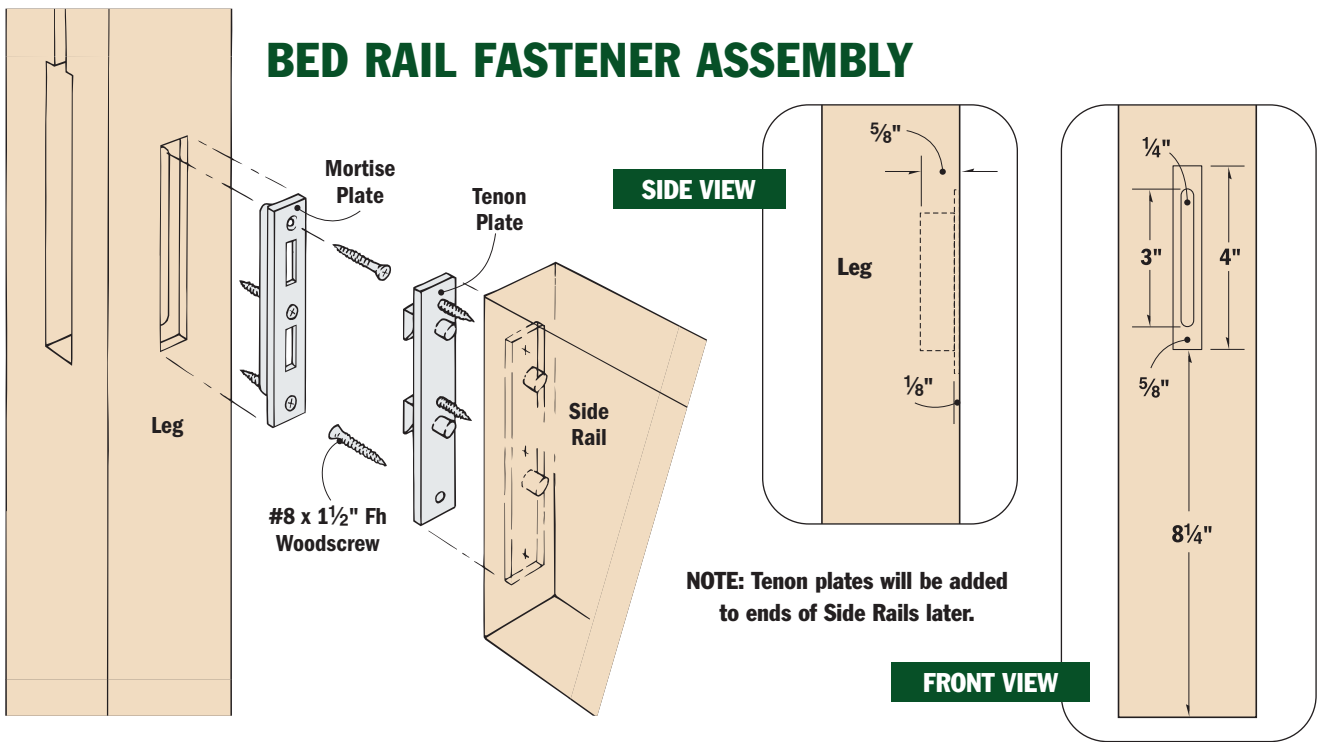

ADD MORTISE PLATES

Once all of the mortises have been added to the legs, the next step is to attach bed rail fasteners. These fasteners are easy to install and make taking a bed frame apart a snap. And the best part is you won't need any tools to disassemble it. (For sources of these fasteners, see [page 59](#).)

If you take a look at the drawing above, you'll notice that the bed rail fasteners consist of two steel plates: a "mortise" plate and a "tenon" plate. They fit together like a locking mortise and tenon joint. The "mortise" plates are attached to the legs, while the "tenon" plates are attached to the

ends of the side rails. Don't worry about the tenon plates right now. They'll be installed later when you get to the side rails.

To attach the mortise plates, start by laying out a "stepped mortise" on the *inside* edge of each leg. I went ahead and set the legs out as they'll be when the bed is assembled, then I laid out the mortises according to the dimensions shown in the *Side* and *Front Views* above. Each plate is centered on a leg, 8 1/4" up from the bottom edge.

STEPPED MORTISE

To make a stepped mortise, I chucked a 1/4" brad-point bit in a drill press, then made a series of 5/8"-deep overlapping holes (Fig. 3). These holes provide room for the tapered

hooks on the ends of the tenon plates. Then you'll need a 5/8" Forstner bit to drill a series of overlapping holes, 1/8"-deep for the plate itself (Fig. 4). Once that's complete, you can clean up the corners and the sides of the mortise that hold the plate with a sharp chisel. The deeper holes for the tenons are left rough.

After cutting stepped mortises in all four legs, a mortise plate can be mounted in each leg as shown in the photo at left.

Note: The slots are not centered on the mortise plate, so be sure the slot closest to the top of the plate is oriented nearest the top of the leg when it's installed (see detail below).

ROUT STOPPED CHAMFERS

If you take a look at the photo on [page 38](#) and [39](#), you'll see the legs are more than just square posts. To dress

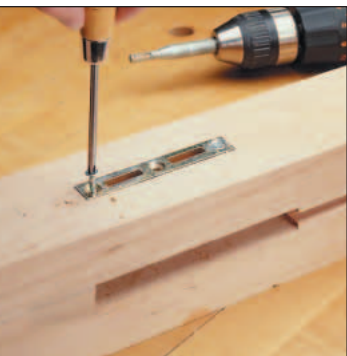

When attaching the mortise plate to the leg, be sure the slots nearest the end of the plate are oriented towards the top of leg.

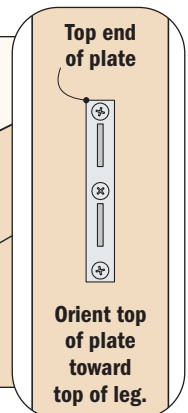
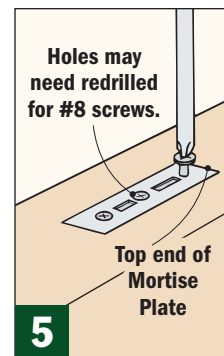
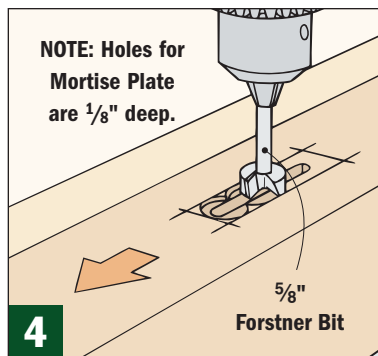
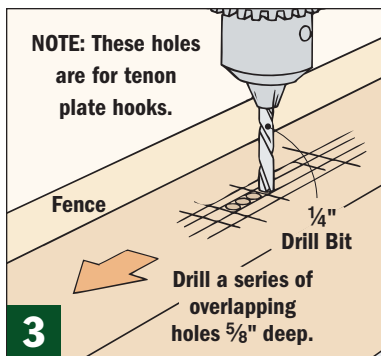

them up, I started by adding stopped chamfers to the edges of each leg and curved tapers at the bottoms.

You can rout the stopped chamfers freehand by drawing a stop mark and routing up to that point. But cherry has a tendency to burn right at the beginning and end of each chamfer, so instead I prefer to clamp stop blocks to the workpiece. With the blocks in place, I'm able to start the router with the bearing on the stop block and then I can turn the corner smoothly into the leg. (For more on this procedure, see [page 15](#).)

CUT THE CURVED TAPER

The legs for the Heirloom Bed are a full 3" square. To give them a little more graceful appearance, I added a short, curved taper on the *inside* faces of the legs (see photo).

Since there are two cuts on all four legs, it's best to use a template to lay them out. I used 1/4" hardboard for the template and transferred the curve using the Leg Taper Pattern above. (To learn more about transferring patterns, see [page 16](#).)

Once the template is complete, use it to lay out the curves on the leg (*Step 1* at right).

I used a band saw for the tapers, cutting slightly outside the layout lines. Making the first cut was simple (*Step 2*), but it helps to re-attach the waste piece with double-sided carpet tape to make the second cut. This way you only have to make two layout lines, and the leg has a solid support all the way through the cut (*Step 3*). Once the cutoff has been reattached make the second cut.

LEG TAPERS

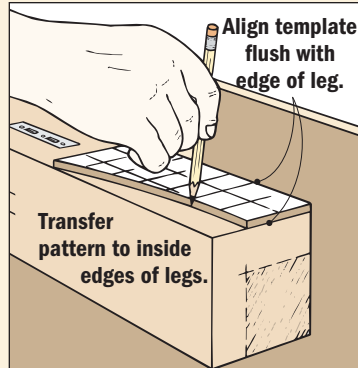

STEP 1: Use the pattern to lay out a hardboard template for the curved taper. Then mark the two inside edges to be cut on the leg.

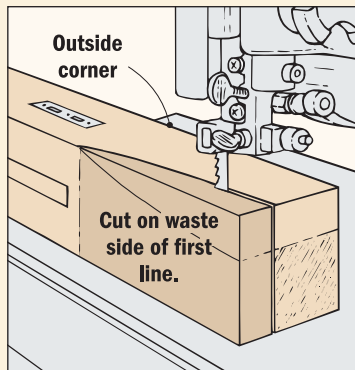
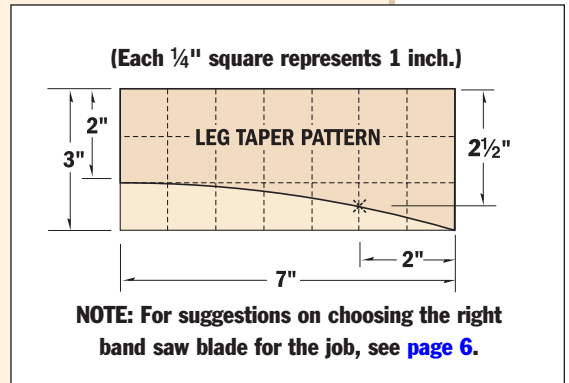

STEP 2: Make the first cut on a band saw. Leave at least 1/16" on the waste side of the line and save the cutoff to help make the second cut.

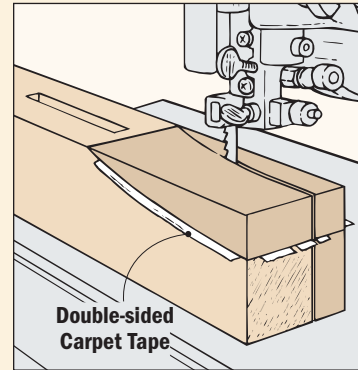

STEP 3: Reattach the waste piece to the leg with double-sided carpet tape. Now follow the layout line for the second cut.

Now sand the tapers up to the layout lines with a drum sander. And soften the remaining edges of the leg using a handheld router (*Fig. 10*). Where the router won't reach on the inside edge of the tapers, sand them

just enough to break the corner. Finally, I clamped the leg in a bench vise and rounded over the bottom edges (*Fig. 11*). This looks nice and will keep the end grain from splintering when moving the bed.

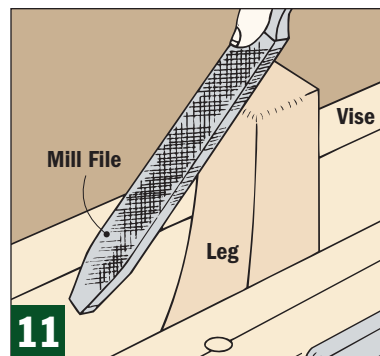
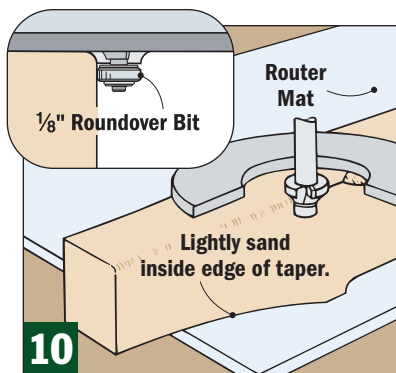
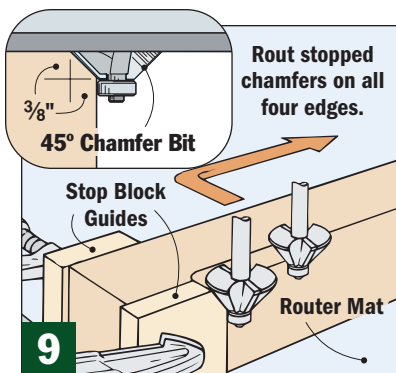

HEADBOARD/FOOTBOARD ASSEMBLIES

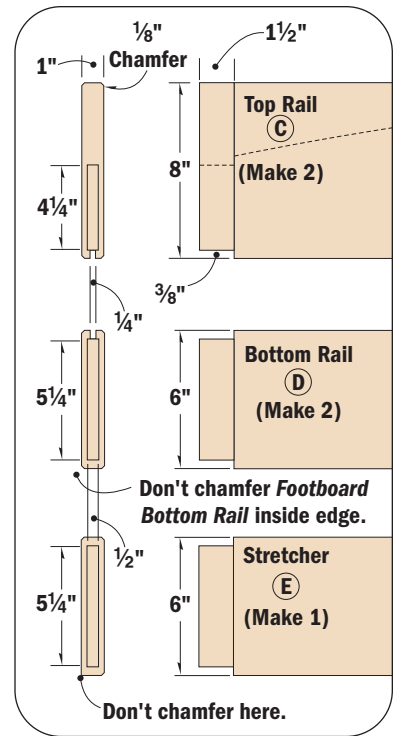
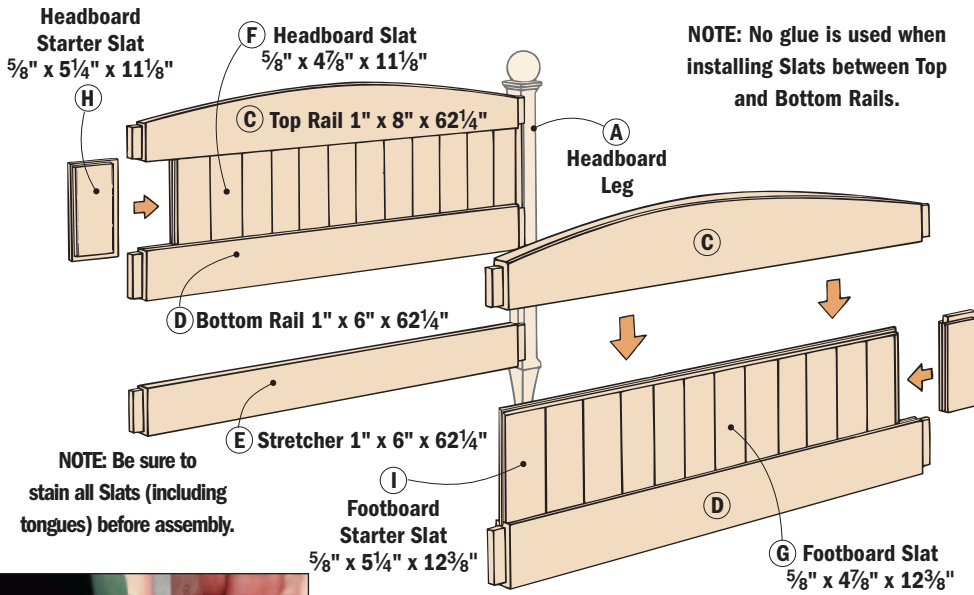

When cutting tenons on a table saw, cut the shoulders a little shorter than the cheeks. Then use a sharp chisel to trim shoulder flush.

BUILD THE RAILS

Once the legs are complete, work can begin on the headboard and footboard rails. As you can see above, each set of legs is joined with a pair of rails. And the headboard also has a stretcher to add stability.

The top rails (C) are a full 8" wide with a long, decorative curve cut along the top edge. I had trouble finding boards this wide, so I glued up two 4 1/2"-wide pieces of 5/4 stock and then planed them to 1" thick. Because the top rails are a focal point of the bed, I spent some extra time finding boards that matched as closely as possible. (See page 17 for tips on grain and color matching.)

Now cut the top rails (C) to

length (the curve is added later), and the bottom rails (D) and the stretcher (E) to finished width and length (see *Headboard/Footboard Assemblies*).

Next, change to a 3/4" dado blade in the table saw to add the 1 1/2"-long tenons on the ends of the rails and stretcher. Cutting tenons on boards this long can be difficult, so I attached a long extension fence to my miter gauge to make it a little easier.

Then I used the rip fence as a stop to set the length of the tenon. As you can see in *Figure 12*, I cut the cheeks of the tenon first. Then I raised the dado blade to cut the top and bottom edges of the tenon (*Fig. 13*). Note: It's a good idea to cut the shoulders a little shorter than the cheeks. Then as shown in the photo, you can come back later with a sharp chisel and carefully trim the shoulders perfectly flush.

GROOVE FOR THE SLATS

There's one more thing to do before cutting the curve on the top rails. A long, centered groove (to hold the slats) is added to one edge of the top and bottom rails. To make this cut, I switched to a 1/4"-wide dado blade in the table saw (*Fig. 14*).

Set the rip fence so the groove is centered on the rail and clamp a featherboard to the table to hold the workpiece tight against the rip fence. Make two passes, flipping the workpiece end-for-end to ensure the groove is exactly centered.

CUT THE CURVED TOP RAIL

Finally, once the grooves have been added, I cut the curve on the top rails. And to make the curved top

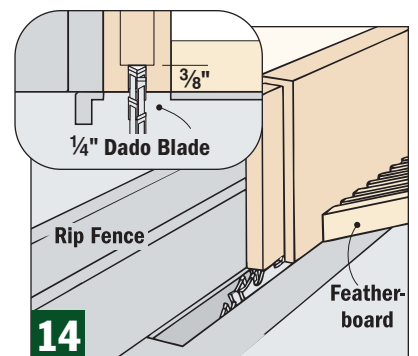
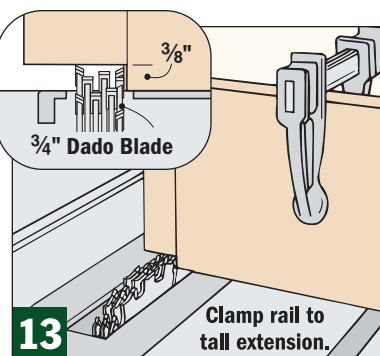
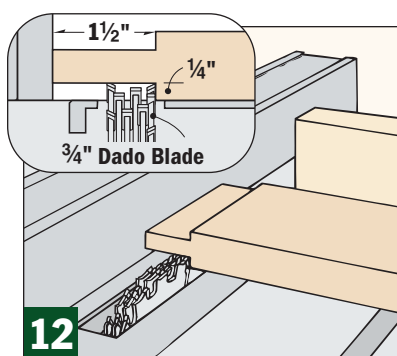

TOP RAIL CURVE & TENON

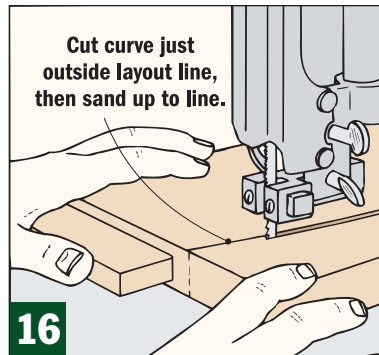
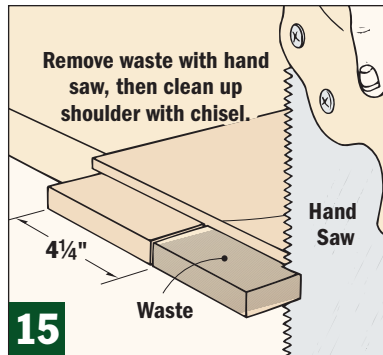
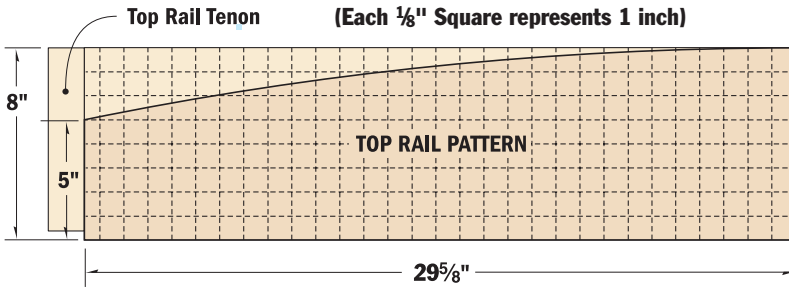

piece easier to lay out, I again used a pattern to make a template. The *Top Rail Pattern* above is actually a pattern for a half-template.

As shown in the photo, the trick to using it, is to line up the long straight edge of the template with the bottom edge of the rail and the narrow end with the shoulder of the tenon. Draw the first portion of the curve, then flip the template end-for-end to finish laying it out.

I also found that making the long cut is easier if you remove part of the

tenon first. A hand saw and a sharp chisel make quick work of trimming the waste from the tenon (*Fig. 15*).

Now carefully cut the curve on the band saw, again staying on the waste side and sanding up to the line (*Fig. 16*).

Finally, I added a 1/8" chamfer to the top and bottom edges of the rails and stretchers. Note: Don't chamfer the bottom, inside edge of both the stretcher or the bottom rail of the footboard. Cleats are added later.

SLATS

The last step in constructing the headboard and footboard is to make the slats. They're cut from 5/8"-thick stock and slide together with tongue-and-groove joinery. To determine their size, in case the mortises



Make laying out the curve for the top rails easier by using a pattern to create a template.

weren't laid out exactly, it helps to first dry-assemble the frames and measure the distance between the top and bottom rail grooves to find the length of the slats. (Mine were 11 1/8" for the headboard and 12 3/8" for the footboard.)

Now lay out the width of the slats as shown in the *Headboard/Footboard Assemblies* drawing. There are a total of 12 headboard slats (F) and footboard slats (G) and a headboard starter slat (H) and footboard starter slat (I) in each assembly. The starter slats are actually 3/8" wider than the others because there's a tongue on both long edges. Once they've all been laid out, cut the slats to size.

Now use the *Groove Detail* drawing and the *Side Tenon* and *End Tenon Detail* drawings below to determine the location and size of the tongues and grooves. Once they've been laid out go ahead and make all the cuts for the slat joinery.

Finally, take a look at the *Chamfer Detail* drawing. You'll notice I added a chamfer to the long edges of all the slats using a V-groove bit mounted in a router table. Set the fence and raise the bit to make a 1/16" chamfer on the groove edge, then reset the fence to chamfer the tongue edge.

SLAT DETAILS

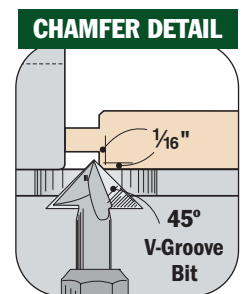
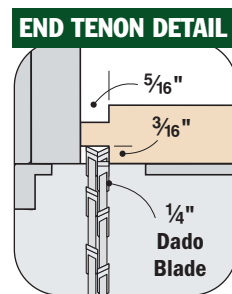
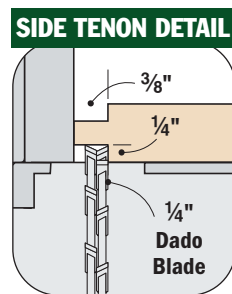
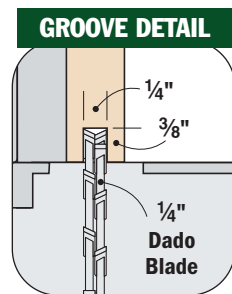
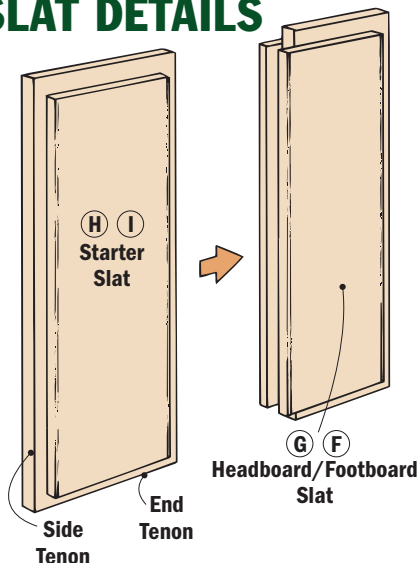

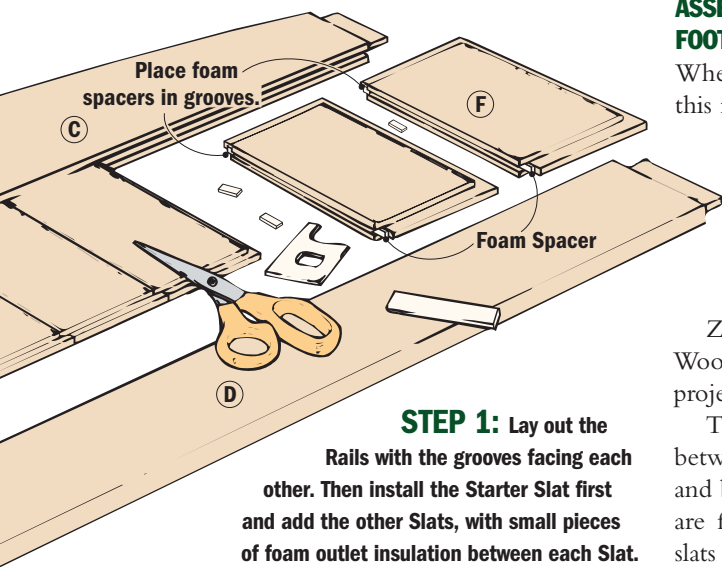

STEP 1: Lay out the Rails with the grooves facing each other. Then install the Starter Slat first and add the other Slats, with small pieces of foam outlet insulation between each Slat.

ASSEMBLE HEADBOARD AND FOOTBOARD

When working on a project with this many pieces, I always break the assembly down into easy-to-manage steps. The first step is to stain the slats (including the tongues) before installing them. I used a mixture of three parts Zar Cherry stain and one part Woodkote Jel'd Cherry stain for this project. (See [page 60](#) for sources.)

The next step is to install the slats between the rails. I arranged the top and bottom rails so that the grooves are facing each other. Because the slats need room to expand and contract, don't glue them in place.

(They'll be "trapped" once the legs are installed.) To take up any "play" between the slats, I cut up thin strips of foam outlet insulation and inserted them in the slat grooves (see *Step 1* at left).

Now prop the rails on some scrap and install the slats between the rails. Begin with a starter slat and space them as evenly as possible, working from left to right. Once everything's assembled, place a short bar clamp, centered on the length of the rails, to hold the slats in place (*Step 2*).

The last step is to glue this sub-assembly and the stretcher between the legs (*Step 3*). With everything assembled, these units are more than 5 feet long. And since my pipe clamps wouldn't reach, I decided to use "strap clamps" instead.

They're easy to use and they work great, just slide them over the legs and line one up over each rail. Place cardboard under the ratchets to protect the rails, then tighten the clamps to pull the legs together. Make sure everything is square before putting the headboard aside. Then repeat the entire process for the footboard.

STEP 2: A bar clamp holds the assembly together temporarily until the legs are added. Prop up the Rails with scrap to make assembly and clamping easier.

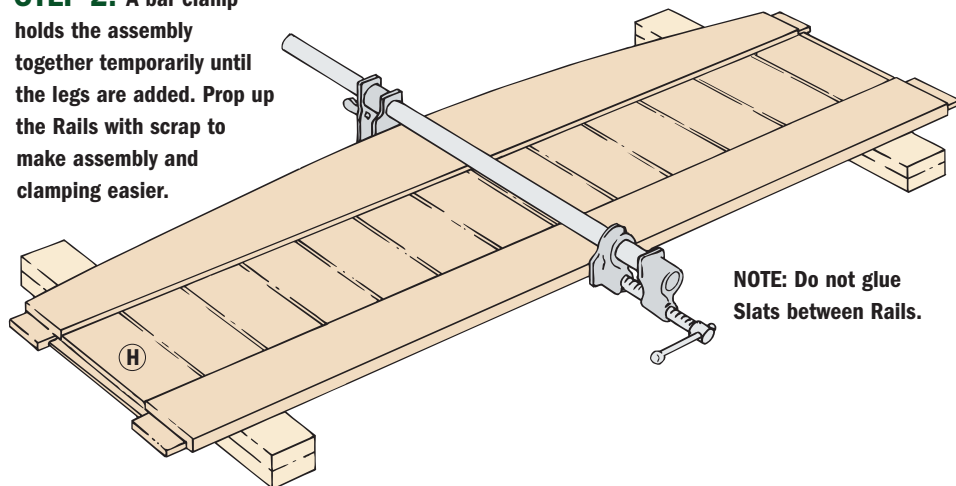

NOTE: Do not glue Slats between Rails.

STEP 3: Apply glue to the tenons and mortises and install the Legs. Square up the assembly and add strap clamps over each Rail and the Stretcher until dry.

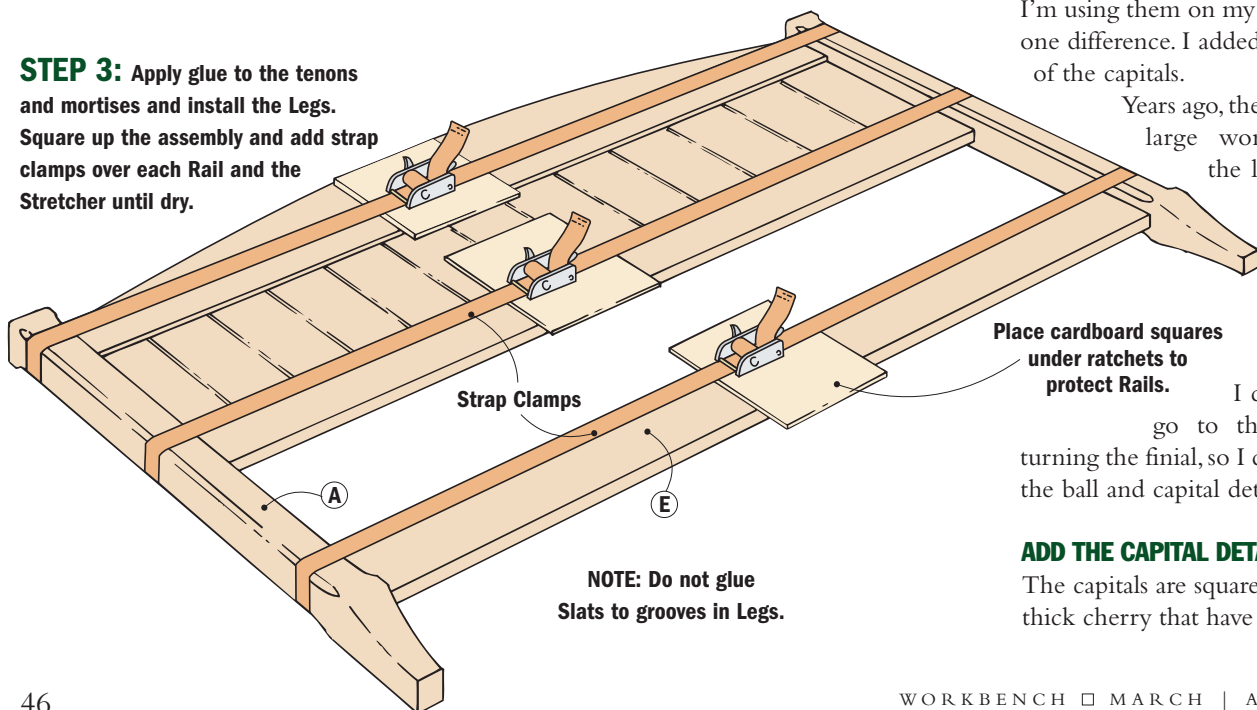

NOTE: Do not glue Slats to grooves in Legs.

CAPITALS AND FINIALS

If you take a look at the deck article on [page 22](#), you'll see we used a cap on the tops of all the posts. The caps are functional, as well as decorative. I'm using them on my legs too, with one difference. I added a ball on top of the capitals.

Years ago, the end grain on large workpieces like the legs would be turned on a lathe. This produced what was called a finial.

I didn't want to go to the trouble of turning the finial, so I decided to use the ball and capital details instead.

ADD THE CAPITAL DETAILS

The capitals are square pieces of 1"-thick cherry that have a cove routed

CAPITAL DETAIL

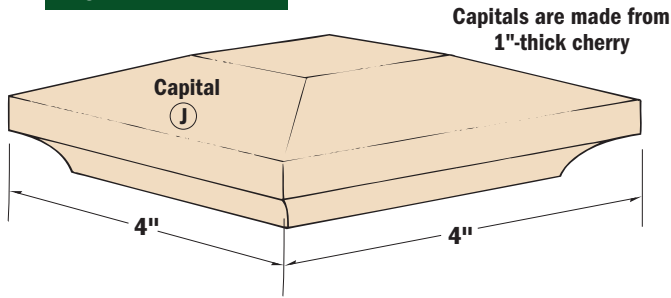

Capitals are made from 1"-thick cherry

To work on the Capitals safely, screw them to a piece of 3/4" scrap. Make the cut, then rotate them 90° to continue.

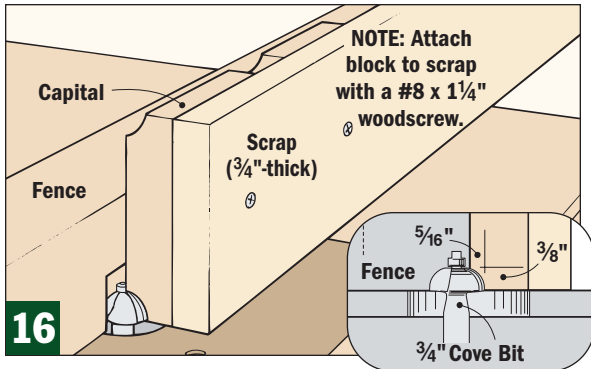
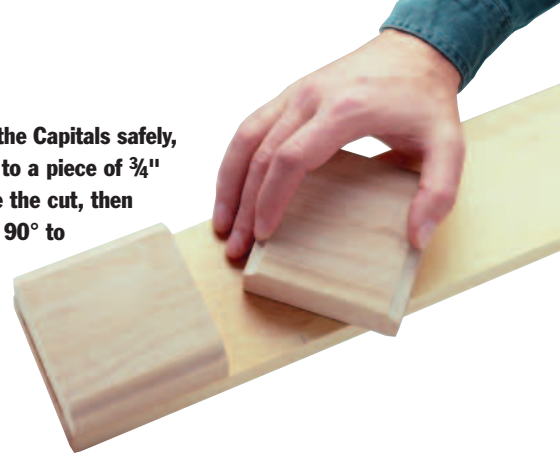

16

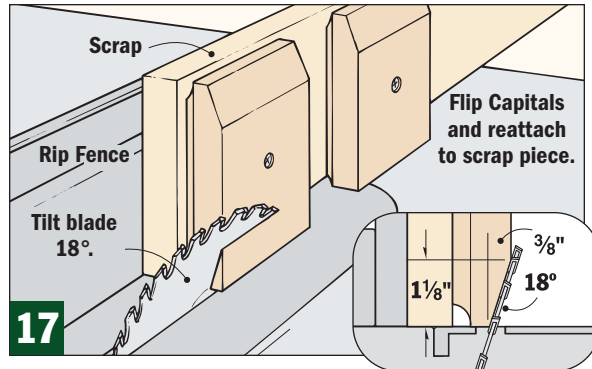

17

on one side and a chamfer added to the other. These are small pieces, so I needed a safe way to add these details. To do this, I ripped a long piece of scrap to match the width of the capitals (J) (see photo).

Clamp two of the blocks to the scrap and attach them with screws. Then use a cove bit in a router table to rout the cove. As shown in *Figure 16*, the bit is partially buried in the fence so that only a portion of it is exposed. Rout a cove in one edge, then rotate the blocks 90° to rout the rest (see photo).

Finally, flip the cherry blocks over and reattach them to the scrap piece. I cut the chamfers using a table saw. Tilt the blade 18° and cut them as shown in *Figure 17*.

SAND THE BIRCH BALLS

Once the capital is completed, begin work on the balls (K). (I used birch balls since I couldn't find 3"-dia. cherry balls.) In order to fit them to the capitals, you'll need to create a flat spot on an edge of the ball. Grain orientation is also important. They look best if the grain is running parallel to the flat spot. So I built a jig to help do this. It's just a U-shaped box with some adhesive-backed sandpaper to

hold the ball in position while sanding it on a disk (or belt) sander, see *Ball Sanding Detail* below.

Now look at the drawing at the far right below to see how the ball and capital are mounted to the post. I used a modified version of the mounting jig on [page 29](#) to align and drill the holes for dowels to mount the capitals.

Once the dowel holes are drilled, simply predrill and countersink for the woodscrews (see *Finial Assembly*).

Note: I used Minwax Wood Conditioner to prep the end grain on the balls. Then I stained them with the cherry stain mixture prior to installing them. (See [page 60](#) for sources.)

FINIAL ASSEMBLY

BALL SANDING JIG

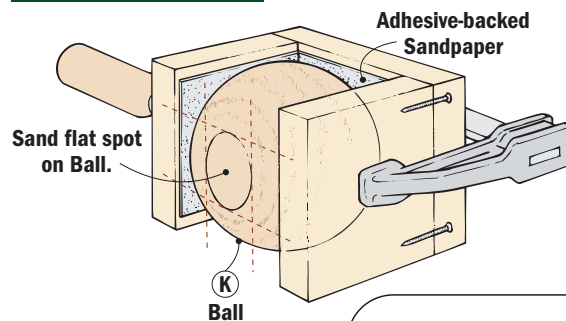

NOTE: Build jig from scrap ripped to 3" wide.

BALL SANDING DETAIL

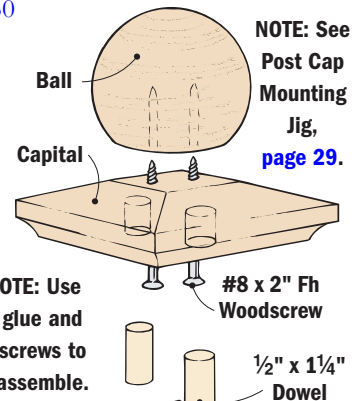
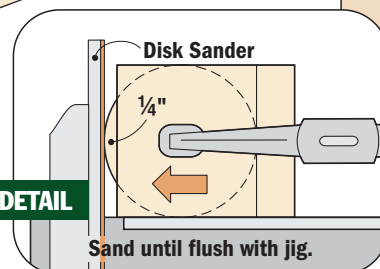

NOTE: Use glue and screws to assemble.

#8 x 2" Fh Woodscrew
1/2" x 1/4" Dowel



The tenon plate portion of the Bed Rail Fastener is mortised into the ends of the Side Rails.

SIDE RAILS

Now that you've finished the headboard and footboard assemblies, all that's left is to build the side rails. In order to continue with the heirloom look, I dressed them up with

an ogee block at each end. Ogee blocks originally had a structural function, but on my bed they're added for looks only (see photo).

ADD THE TENON PLATES

As you can see in the *Side Rail Assembly*, the side rails (L) are just a couple of boards cut to size. As you'll remember from page 42, they're attached to the legs with bed rail fasteners. The tenon plate half is fit into a mortise in the ends of each side rail (Figs. 18 and 19).

I was worried though, that the screws that hold the plates to the rails would be screwed into end grain. To give the screws some cross grain to grip, I decided to add $\frac{3}{4}$ " cross-dowels. You'll want to sand an edge of the dowel to allow for glue squeeze-out, then insert them into a hole drilled into the top edge of the side rail before adding the blocks (Fig. 20).

OGEE BLOCKS

Once again, you'll need to use a template to lay out the ogee blocks (M) (see pattern at left). When you have them cut out and sanded smooth, simply glue them to the top edge of the side rails, with the ends flush. Then the two outside and the top inside edges of the rails are chamfered. Note: I used a sharp chisel to chamfer the inside corner where the ogee block meets the side rail (see *Chamfer Detail*).

CLEATS

Besides connecting the headboard to the footboard, the side rails have one other important function — they help support the mattress. Actually, the mattress set rests on a plywood panel supported by cleats. The cleats (N and O) are glued and screwed to the rails and stretcher (Fig. 21).

I cut the mattress panels (P) from a full sheet of $\frac{3}{4}$ " plywood and made a diagonal cutout on the corners to fit around the legs (Fig. 21).

Finally, I applied the stain mixture to the remaining parts of the bed and then finished everything with three coats of an oil varnish, sanding between coats. 🪵

SIDE RAIL ASSEMBLY

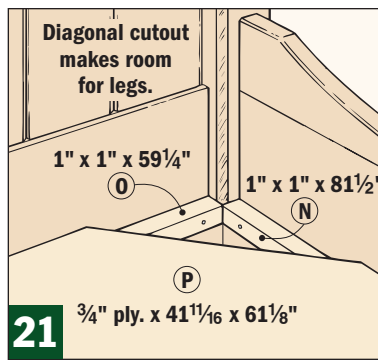
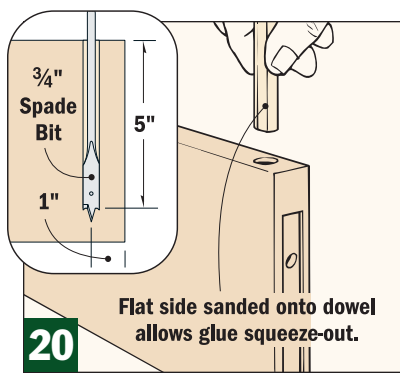
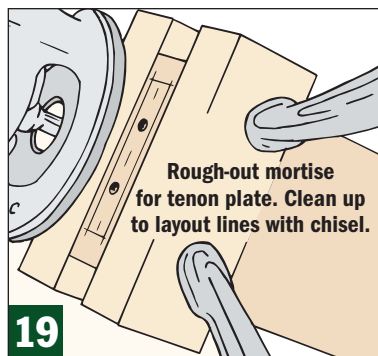
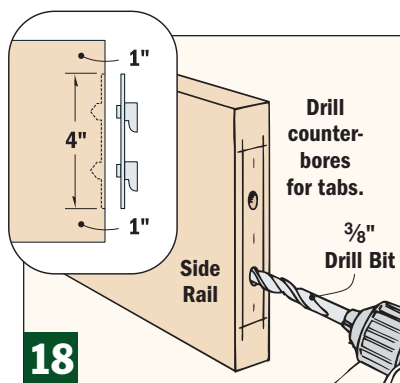
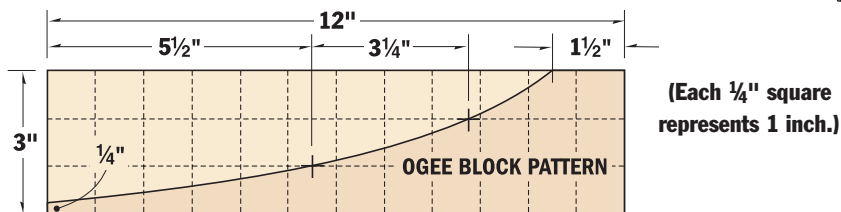
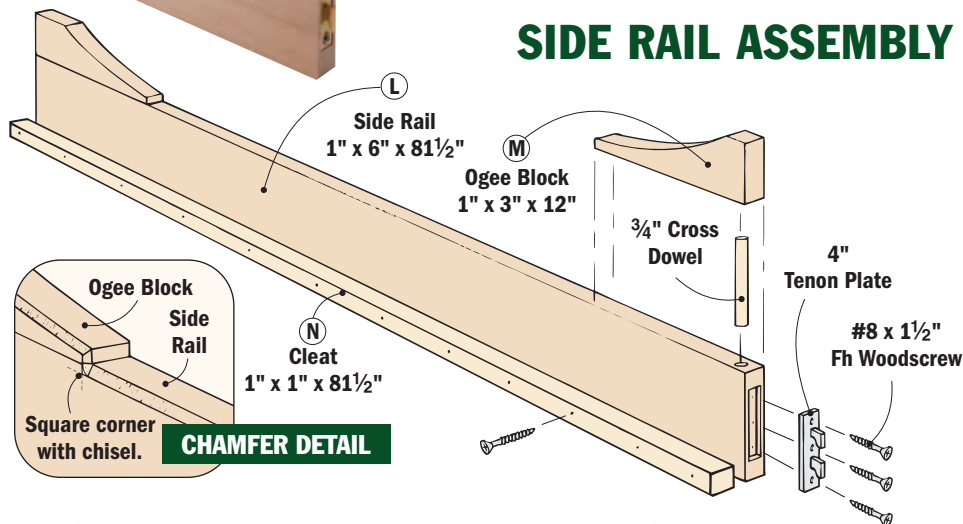

Twin or King?

TWIN-SIZE BED

There aren't a lot of changes necessary to make a twin-size version of the Heirloom Bed. The headboard and footboard rails and the stretcher are all shorter, of course, but the rest of the bed is essentially the same.

By shortening the top and bottom rail though, I had to change the number of slats used to make the panel. Also, the width of the slats has changed, but the length for the slats hasn't, see drawing at right.

But as with the queen-size bed, I found that it's still best to dry-assemble the legs and rails for both the headboard and the footboard to determine the actual size of the slats. My slats were $4\frac{9}{16}$ "-wide x $11\frac{1}{8}$ "-long (headboard), $4\frac{9}{16}$ "-wide x $12\frac{3}{8}$ "-long (footboard). The starter slats were $4\frac{15}{16}$ "-wide.

I also had to change the length of the headboard and footboard cleats. And again, since mattress sizes vary, you may want to use plywood panels here, as well. Size the panels for your bed frame and also make sure to trim the corners. This allows the plywood panel to fit around the legs.

KING-SIZE BED

King-size mattress sets are actually made up of a mattress and two twin-size box springs. So a center leg

assembly is needed to provide extra support for the middle of the bed.

Other changes to the king-size headboard and footboard include lengthening the top and bottom rails and the stretcher, as well as adding four more slats (sized appropriately). And once again, you'll need to use plywood panels for support, see the drawing at bottom left.

The center leg and bracket assembly is attached to the underside of the plywood panels. To build this assembly, first make a center leg from a length of hardwood. The leg is then screwed to a support leg bracket, also made from scrap hardwood. And to avoid screwing into the end grain of the leg when it's attached to the bracket, make sure to orient the grain for the leg piece lengthwise (horizontal). (See *King-Size Support Leg* drawing below.)

Next, screw the leg on the support leg bracket with woodscrews. Then attach the assembly to one plywood panel, centering it along one edge. You can use some glue here, then screw it in place.

Now lower the first panel down over the cleats at one end of the opening. To complete the assembly, add the second panel and screw the support bracket in place from above, as shown in the drawing below left.

BEDSIDE TABLE

The Heirloom Bed has so many unique features, we thought you might want to build matching bedroom furniture. So

we'll be providing plans for a Bedside Table in the [May/June 2001 issue of Workbench magazine](#). Look for it sometime in the latter part of April.

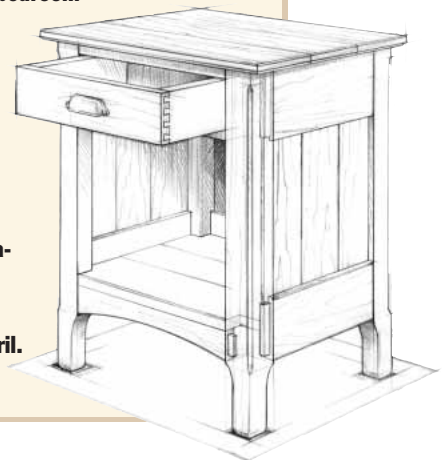

TWIN-SIZE BED

Headboard Slats
 $\frac{5}{8}$ " x $4\frac{9}{16}$ " x $11\frac{1}{8}$ "

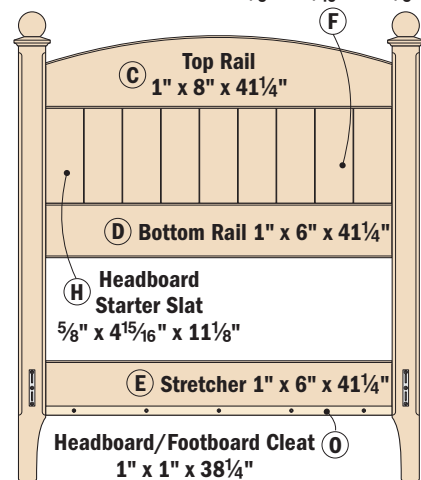

Footboard Slat (G) $\frac{5}{8}$ " x $4\frac{9}{16}$ " x $12\frac{3}{8}$ "
Footboard Starter Slat (I) $\frac{5}{8}$ " x $4\frac{15}{16}$ " x $12\frac{3}{8}$ "
Mattress Panel (P) $\frac{3}{4}$ " x $41\frac{1}{16}$ " x $40\frac{1}{4}$ "

KING-SIZE BED

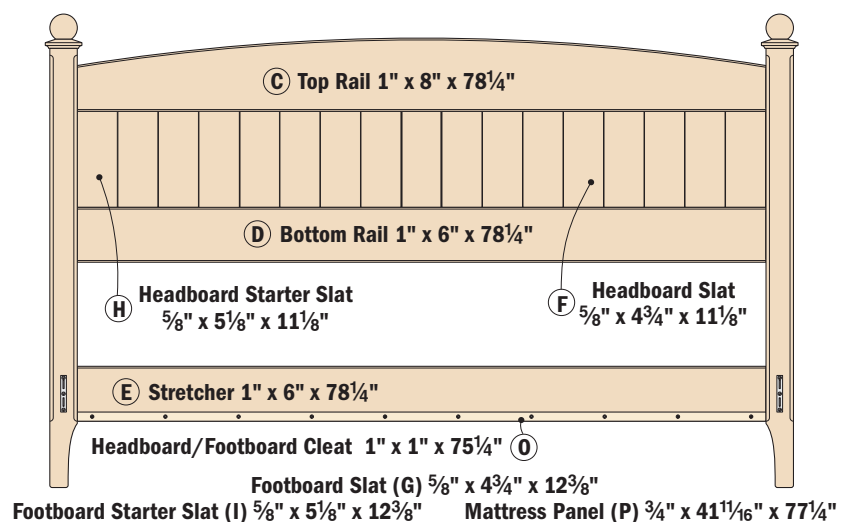

KING-SIZE SUPPORT LEG

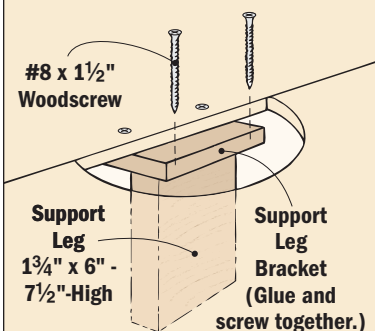

NOTE: Center Bracket on bottom of Plywood Panels.



Shelf with a Secret

If you look closely, you'll discover what this project is hiding!

There's more to this CD shelf organizer than what meets the eye. At first glance, there seems to be nothing about the shelf that's out of the ordinary. But it's what you can't see happening that really makes the project unique.

I'll give you a clue: What look like stationary dividers really aren't. What you don't see in the photo is that the dividers easily slide along a hidden channel down the middle of the shelf. As your CD collection grows or your musical tastes change, simply adjust the dividers to make more room.

The dividers have another purpose, too — They keep your CDs from falling over. And if you like, you can even remove them entirely.

When designing the shelf, the trick was coming up with a way to make the dividers adjustable without adding clunky hardware or using complicated joinery. I'll admit it took a couple of tries to hide the sliding system, but the solution ended up being pretty simple.

The basic concept is that the dividers attach to small wooden slides. These slides move along a channel in the bottom of the shelf so they're hidden from view. As you can see in the *Assembly View* on the [facing page](#), the sliding mechanism doesn't require any special hardware. And the joinery is easy to make, too.

Before you get started building, you'll have to decide what material to use and how long to make the shelf. I chose maple because of its clean, smooth look. That also makes it a good choice for projects that involve sliding joinery. And I built the wall unit 36" long, which provides plenty of space for CDs and other small items. This length also allows you to fasten the shelf to two



CD SHELF ASSEMBLY VIEW

OVERALL SHELF SIZE: 6⁷/₈"W x 36"L x 6⁷/₈"H

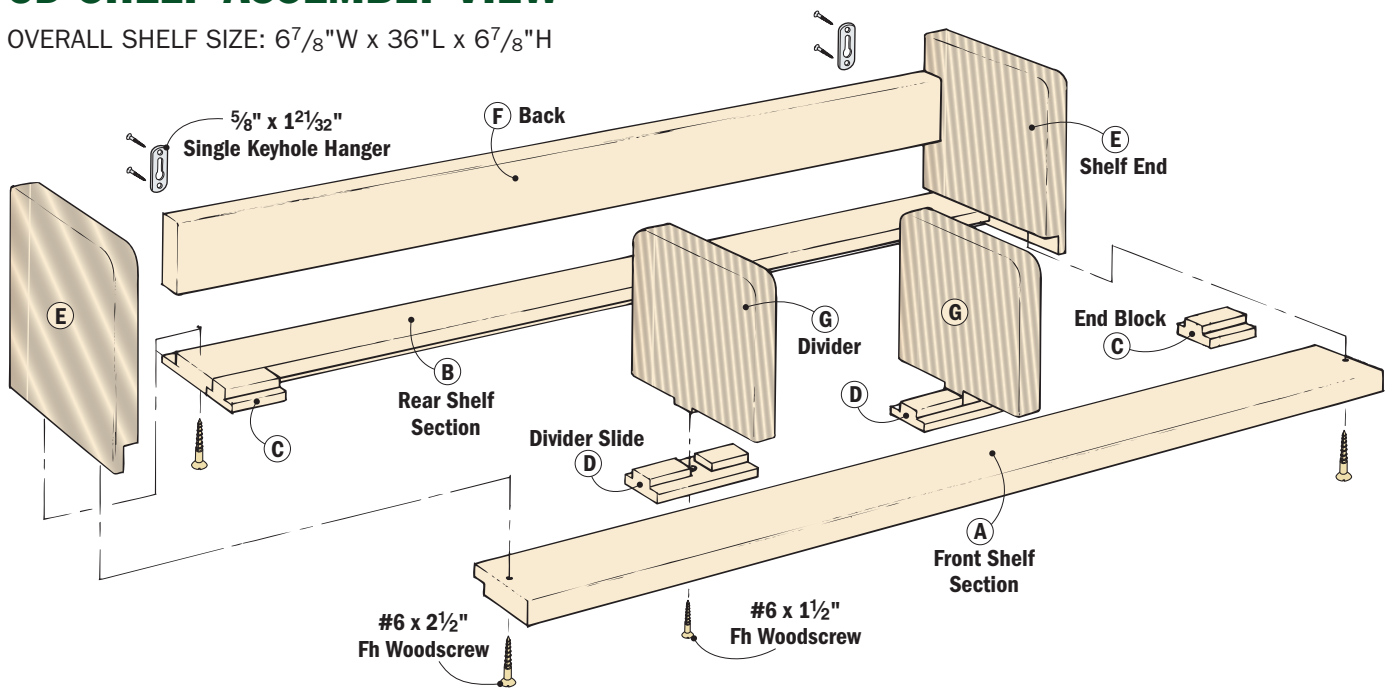

16"-on-center wall studs. If the shelf were any longer, the weight of the CDs could cause it to sag. But as you can see in the small photo at the bottom of the [facing page](#), a shorter version of the shelf looks great sitting on a computer desk.

And with only 11 pieces to cut and assemble, this shelf makes a great weekend project.

BUILDING THE SHELF

The real key to this project is the hidden channel that runs down the middle of the shelf. What makes it possible is the fact that the shelf is actually two sections: a front section (A) and a rear section (B). Gluing end blocks (C) between the two sections creates an opening.

To make the shelf, start by routing a rabbet in the bottom face along both edges of an oversized blank (8" x 36"). I did this on a router table using a 3/4" straight bit (Fig. 1). These rabbets will create a space for the divider slides to fit into. You'll learn more about the slides in a little bit.

Next, rip the two shelf sections to finished width from the outside edges of the blank (Fig. 2). You should end up with one shelf section that's 5/8" wider than the other. After ripping the pieces, set the front section aside until the end blocks are ready.

The rear shelf, however, still needs a rabbet to accept a back for the unit. You can use the same 3/4" bit to cut this rabbet, only raise it

MATERIALS LIST

A (1) Front Shelf Sect.	3/4" x 2 3/4" x 35 1/2"
B (1) Rear Shelf Sect.	3/4" x 3 3/8" x 35 1/2"
C (2) End Blocks	3/4" x 1 1/2" x 2"
D (2) Divider Slides	3/4" x 1 1/2" x 4"
E (2) Shelf Ends	3/4" x 6 7/8" x 6 7/8"
F (1) Back	3/4" x 2 1/2" x 34 1/2"
G (2) Dividers	3/4" x 5 3/4" x 5 1/8"

HARDWARE:

- (4) #6 x 2 1/2" Fh Woodscrews (bronze color)
- (2) #6 x 1 1/2" Fh Woodscrews (bronze color)
- (2) 5/8" x 1 21/32" Single Keyhole Hangers with screws

slightly to cut 1/2" deep and don't worry about burying it in the fence (Fig. 3). Note: Be sure to rout the rabbet in the correct face — opposite the previously cut rabbet.

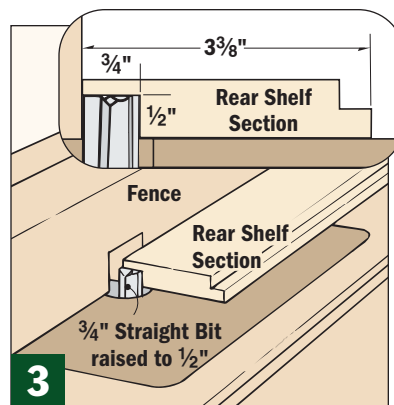
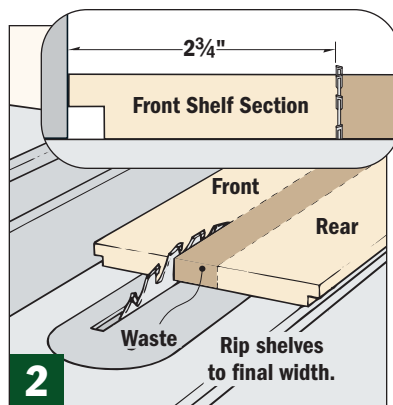
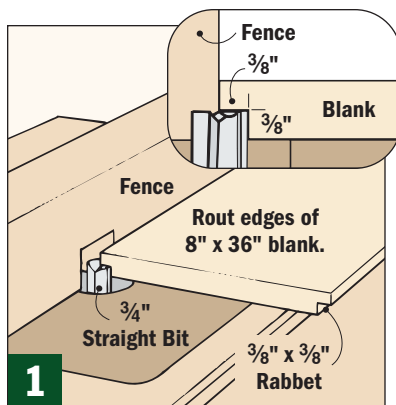

T-BLOCK BLANK $1\frac{1}{2}$ "W x 20"L x $\frac{3}{4}$ "H

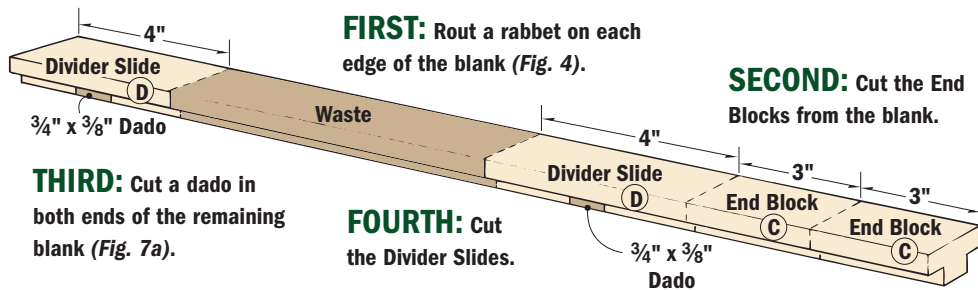

FIRST: Rout a rabbet on each edge of the blank (Fig. 4).

SECOND: Cut the End Blocks from the blank.

THIRD: Cut a dado in both ends of the remaining blank (Fig. 7a).

FOURTH: Cut the Divider Slides.

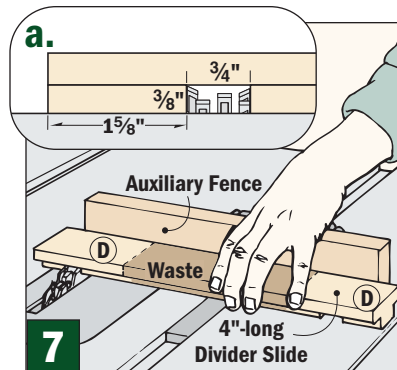
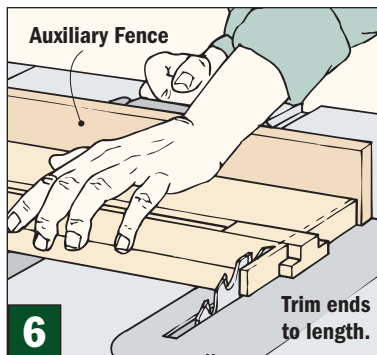
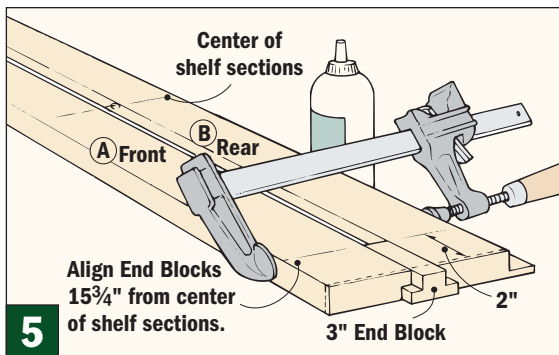
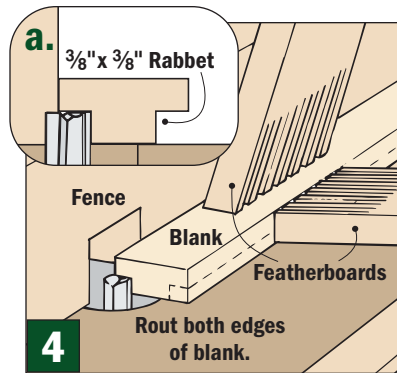

MAKING THE END BLOCKS

As mentioned earlier, the shelf sections are held together by two end blocks (C). These rabbeted pieces are pretty small. So for safety reasons, I decided to cut them out of a long blank (see above). You can use this same blank for the divider slides (D).

Start by routing a rabbet along both edges of the blank. These rabbets have to be accurate. So you'll notice in Figure 4 that I used a pair of featherboards to hold the workpiece.

After the edges are rabbeted, cut two 3"-long end blocks (C) from one end of the blank. That's a little longer than their final size, but they'll be cut to final length after being glued up with the shelf sections.

Where you position the end blocks becomes critical because neither the shelf sections nor the end blocks have been cut to exact length yet. Start by measuring $15\frac{3}{4}$ " from the center of the shelf sections in both directions. Align the end blocks in place with these marks (Fig. 5), then glue them in place. Once the glue dries, trim everything to final length on the table saw (Fig. 6). The trick is to make the cuts so each end block ends up exactly 2" long.

Although the divider slides (D) aren't attached for awhile, you can go ahead and cut them from the T-block blank now. You'll notice above that the blank is already rabbeted. So all

you have to do is add a couple $\frac{3}{8}$ "-deep dados in each slide as seen in Figure 7. These dados hold the dividers. Then cut two slides from the blank and set them aside.

SHAPING THE ENDS

The shelf ends (E) start out as a long blank ripped to width ($\frac{6}{8}$ "") with a rabbet in both ends. I used a miter gauge and auxiliary fence when routing to help avoid tearout (Fig. 8). Now cut the ends to length ($\frac{6}{8}$ "").

Next, mark and cut a $\frac{3}{4}$ " radius on both pieces (Shelf End Details). I also softened the top and front edges with a $\frac{1}{8}$ " roundover. The shelf ends can be attached as shown in Step 1 at the top of the facing page.

SHELF END DETAILS

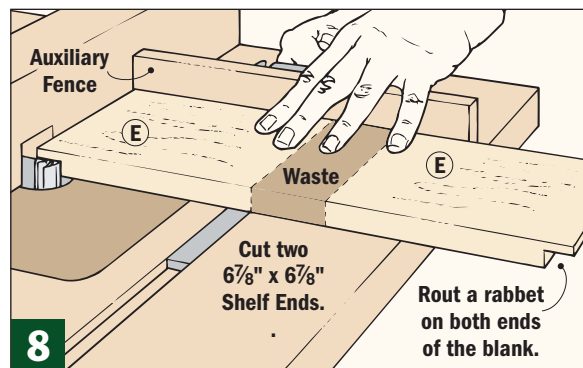
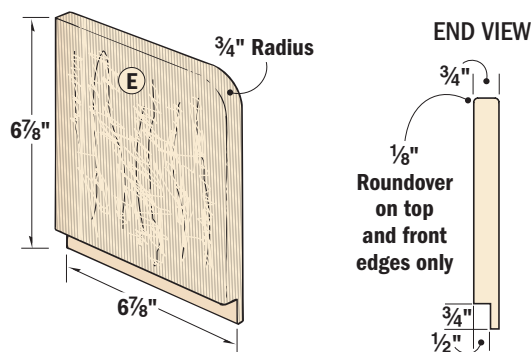

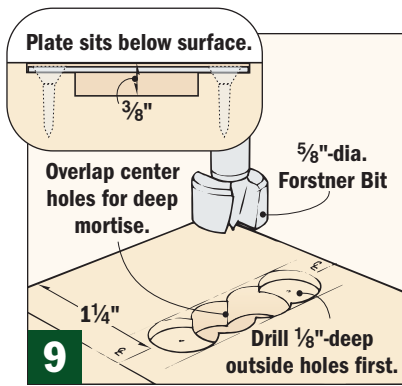

ADDING THE BACK & HANGERS

The basic shelf is nearly complete except for a back (F) and two keyhole hangers for fastening to the wall. I found it easier to drill the mortise for the hangers before attaching the back. The trick is to drill a mortise within a mortise to create room for a screw head. It's easier than it sounds.

First, lay out the location of the hangers on the back so they'll match up with wall studs. Next, use a 5/8"-dia. Forstner bit to drill two 1/8"-deep outside holes for each hanger plate. Using the same bit, drill overlapping 3/8"-deep center holes (Fig. 9). Finally,

ASSEMBLING THE SHELF

STEP 1: Glue and screw both Ends to the shelf.

STEP 2: Measure and cut the Back to fit between the Ends.

STEP 3: Cut mortises in the Back for two Keyhole Hangers (see Fig. 9).

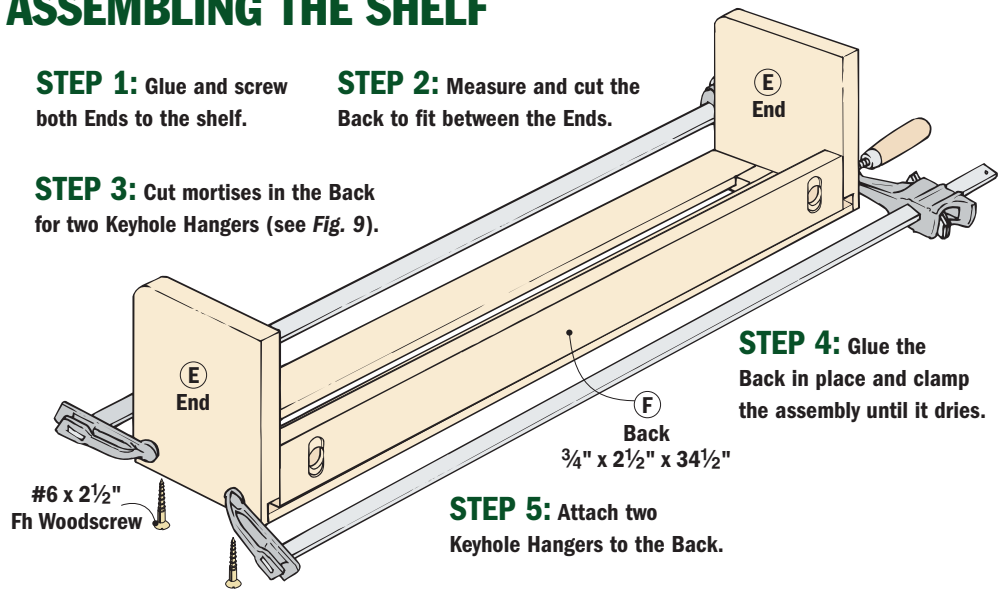

clean up the edges of the mortises with a chisel and drill pilot holes for screws. Now the back can be glued in place and the hanger plates screwed on (see photo at right).

CUTTING THE DIVIDERS

All that's left is to add the dividers (G). First cut them to finished size (note grain direction below). After

cutting a radius and rounding over the top and edges, you can move onto the tabs. These can be cut in a couple steps on the table saw as seen in Figures 10 and 11.

With a standard blade raised 7/16", use the miter gauge and an auxiliary fence to make two shallow cuts (Fig. 10) in each divider. To clear away the waste and complete the tab, stand the divider on its edge and make two more deep cuts (Fig. 11).

DIVIDER ASSEMBLY

FIRST: Predrill shank hole in the Divider Slide.

SECOND: Fit the Divider Slide into the shelf channel.

THIRD: Screw the Divider Slide to the Divider.

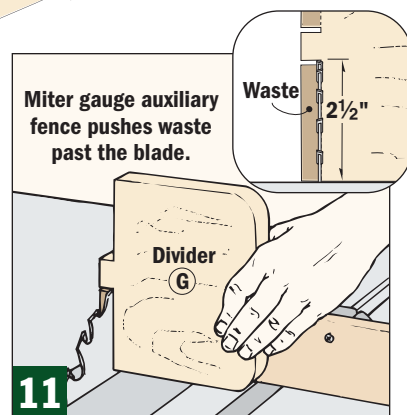
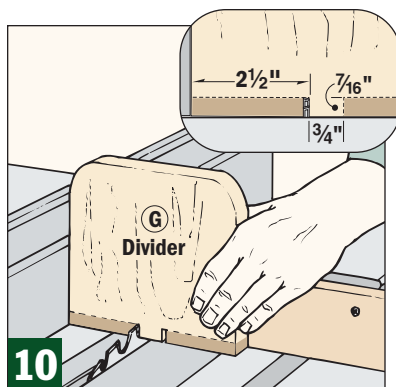
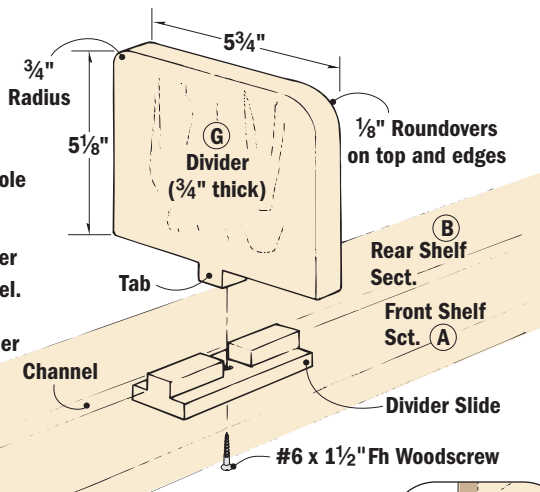

This hanger is a steel plate with a keyhole slot and two holes for screws. See page 60 for information on ordering it.

FINAL ASSEMBLY

Before attaching the dividers, I sanded the shoulders and cheeks of the divider slides to create extra clearance along the rubbing surfaces. (A thin layer of paraffin wax after finishing helps the slide mechanism work better, too.)

Sanding has another advantage. It allows the divider slides to sit a hair above the channel so that the shelf can rest flat on a desk.

As you can see in the *Divider Assembly* at left, there really isn't much to fastening the dividers. Assembly is just a matter of predrilling each divider slide for a countersunk wood-screw. Then fit the slides into the channel underneath the shelf and screw the dividers in place.

To finish up, I stained everything with Zar Honey Maple, followed by two coats of a wipe-on oil finish. This made the maple grain stand out and gave the shelf a smooth look. 📖



Bright Ideas In Lighting

Photo by: Mort Tucker Photography

Solve common lighting problems in your home with the help of design pros.



Courtesy of: Amer. Lighting Assoc.

▲ **Wall lamps reduce the “cave effect” caused by recessed lights alone.**

▶ **Concealed floodlights add depth to stairways and highlight interesting details.**



Photo by: Mort Tucker Photography

You can spend a fortune on furnishings and remodeling. But without the proper lighting scheme, all your hard work and money will get lost in the dark.

Bad lighting can ruin the look of a room, just like good lighting can make a room feel right. To help you get the right feel for your home, we asked two lighting design experts for some advice on how to improve the lighting throughout a house.

“Lighting is that secret ingredient that sets the right mood for every room,” says Pamela Horner, manager of General Lighting Education for Osram Sylvania. “When planning your lighting, think about all the activities that occur in each room, the atmosphere you want to create, and the elements you wish to highlight.”

FOYER, HALLWAYS & STAIRS

Take the entryway for instance. In many homes, entryways are illuminated by a single ceiling light. This makes the space feel cold and sterile. Instead, try a hanging fixture that’s sized to match your foyer.

“The goal is to create an inviting entry point that defines the style of your house,” Horner says.

If you have a stairway leading from the entryway, you can expand the sense of space by casting light upward across a wall (large photo at left). Hallways are another challenging space to light. Wall-mounted lamps spaced 8-10 ft. apart can add visual interest to a dull space (small photo at left). Mount wall lamps (and sconces) 66" from the center of the fixture to the floor so the bulb isn’t visible.



Courtesy of: Philips Lighting Co.

▲ A floor spotlight aimed through a large plant or indoor tree is an excellent way to soften a room with interesting shadows.

FAMILY AND DINING ROOMS

A lot of different activities take place in both the typical family room and dining room. That's why a single type of lighting isn't enough.

"In your family room, first light what you want people to see the most (like artwork above a mantle)," Horner says. "Then move to the next thing (like a plant or indoor tree). That way you'll end up with multiple lights at various heights."

Dining room lighting naturally focuses around the table. "A chandelier with a dimmer is a good choice because the table gets used for more than just dining," Horner says. (You'll find more about dimmers at the end of this article.) Choose a chandelier that's 6" narrower than the table on both sides. It should hang about 30" above the center of the table.

Once you've lit the table, you can move on to the rest of the room. As you can see in the top photo above right, recessed ceiling lights help define the perimeter of a room.

KITCHEN LIGHTING

Creating the best lighting design for your kitchen is like cooking a great meal. You have to have the right recipe and the proper ingredients.

"Think in layers," says Monty Gilbertson, manager for Lighting Design by Wettsteins in Lacrosse, Wis.

The first job is to provide good general, or ambient, lighting. Start with a large central 70-80W fluorescent ceiling fixture. This will provide



Courtesy of: Progress Lighting

▲ Notice how the recessed ceiling lights define the room's perimeter. Wall lamps flanking the artwork adds an additional layer, while a chandelier provides general lighting for dining.

◀ Well-lit kitchens combine different layers of light: general, task and accent.



Courtesy of: Philips Lighting Co.

plenty of well-diffused general lighting. But it may leave you working in your own shadow at the sink, range and countertops. That's why these areas need some creative task lighting.

Individual recessed downlights installed in the ceiling are good choices for task lighting above the sink and range. Use reflector bulbs to direct light to the busy work areas. When used with a dimmer control, decorative pendants above an island counter (see photo at right) provide good task lighting for homework and hobbies. You can dim the lights for dining or entertaining. Low-voltage undercabinet lighting is a good remedy for eliminating shadows on countertops (see photo at right).

"Once you have the plan in mind, use the same color bulbs throughout the kitchen so that the tone of the floor, counters and cabinets will all be the same intensity," Gilbertson says.



Courtesy of: Progress Lighting

▲ Hanging pendants above a kitchen island provide good task lighting and add visual interest to the space.

▶ Low-voltage halogen lights under a cabinet make it easier to see when working. Position lights as close to the front of the cabinets as possible.



Courtesy of: Progress Lighting

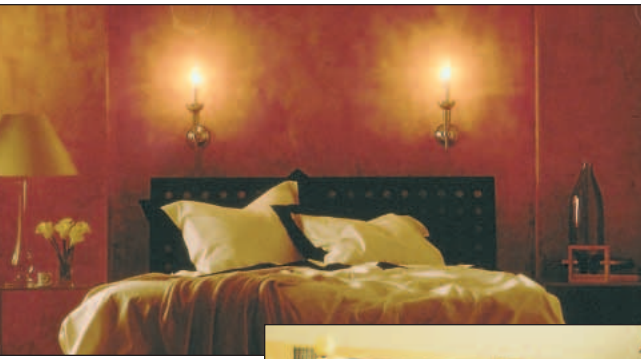

Courtesy of: Osram-Sylvania

BEDROOM LIGHTING

When lighting a bedroom, you'll want to create an overall atmosphere for quiet relaxation as seen in the photo at left. One way to accomplish this is with some wall brackets over the headboard equipped with halogen bulbs.

But the bedroom also is a place for dressing, grooming, reading, and sometimes even watching TV late at night. So you'll also want some general and task lighting to create bright spots for these activities.

One common option is to use a central ceiling fan and light combination with a built-in 40-75W bulb. Then add some table lamps on the nightstands that can be used for reading as seen in the photo at left.

"This provides good overall room illumination for cleaning, sorting clothes, dressing and other general tasks," Horner says. "But there are times when you'll want to turn off the ceiling light and create a more intimate mood with plug-in lamps."

To do this, the wall outlets for the table lamps should be controlled by a switch that's separate from the switch for the ceiling fixture. You might also want to consider using some type of dimmer control on all of the bedroom lights (see the [facing page](#)). This

will give you the flexibility to vary the lighting to suit different moods and activities.

"And don't forget the closet," Horner says. "Choose long-life fluorescent bulbs because you don't want to be changing them very often." For safety, use an enclosed fixture.

BATHROOM LIGHTING

Afraid to look yourself in the mirror every morning? Maybe it's because you're seeing yourself in bad light (see box below). Light naturally creates shadows, and when you combine them with mirrors you need to be extra careful.

Lighting for the face is the most critical light in the bathroom. There are several fixtures designed specifically to provide this bright illumination. In general, you can achieve good lighting with 60-75W incandescent bulbs or 40W fluorescent lights.

If you're using vanity strips with globe bulbs, choose frosted instead of clear to help minimize shadows. For applying makeup, consider special daylight-balanced bulbs. These will give you an accurate sense of how you'll look in natural light.

"A ceiling light for the shower stall and bathtub is a great idea, too," Gilbertson says (see photo at left).

Again, consider bathroom dimmers. This way you can have high light for applying makeup; low light for bathing and relaxation.

▲ Create a relaxing space by dimming bedroom lights.

▶ Table lamps with dimmable compact fluorescent bulbs work well for reading.

Courtesy of: Philips Lighting Co.



Courtesy of: Philips Lighting Co.

▲ Shower lights must be enclosed at least 6 ft. above the waterline.

PUT YOURSELF IN THE BEST LIGHT

Shadow-free lighting around a mirror is important in a bathroom. For small areas, a wall bracket above the mirror (A) will provide enough illumination for the entire room, but it may not eliminate shadows. Adding a pair of lights on each side of the mirror (B) will help get rid of most shadows. In larger bathrooms, additional recessed ceiling fixtures (C) are helpful for general lighting.



Courtesy of: Progress Lighting

PRIMER ON DIMMERS

A room full of lights controlled by a single wall switch is like a stereo with no volume control — it's on and really loud, or off and completely

quiet. That's why lighting controls (see photos below) should be a key part of every room's lighting design.

Switch Replacement: Two of the most popular types of controls you'll find are *rotary* dimmers and *sliding-lever* dimmers. Both replace wall switches and provide full-range, manual dimming control.

Lamp Style: You can also purchase dimmers that control a single table lamp. *In-line* dimmers attach directly to the lamp cord. A *remote-control* dimmer works like a garage door opener. You simply plug the receiver into an outlet, then plug a lamp into the receiver.

Switch Replacement



Rotary



Sliding-Lever

Lamp Style



In-line



Remote Control



“Whatever style you choose, look for one that all family members can operate easily,” Horner says. 

Workbench would like to thank Pamela Horner and Monty Gilbertson for providing information for this article. You'll find a list of useful Web sites for more lighting ideas on page 60.

WANT HELP LANDSCAPING?

Do you have a landscaping problem you don't know how to solve? Share it with us, and we may publish a solution in the next *Take It From a Pro* article. Send a detailed letter about your site and the problem (include photographs if available) to: *Take It From a Pro*, Workbench Magazine, 2200 Grand Ave., Des Moines, IA 50312. Please include your phone number with the letter in case we need to contact you for more information.



Under-Bed Storage

Build this drawer-on-wheels and make good use of wasted space.

The area under a bed in most homes is good for one thing — collecting dust bunnies. But once I finished the *Heirloom Bed* shown on [page 38](#), I decided that space could be put to better use. The local WalMart had plenty of plastic storage boxes, but I just couldn't convince myself to put a plastic box under a solid cherry bed. So I built a cherry box.

There are a couple of things I like about this box. First, it's not connected to the bed, but rolls straight out from under the bed on plastic wheels. And the lid is hinged so you can easily reach inside.

The measurements shown let you get four of these boxes under a queen-size bed. The box's height is $6\frac{3}{4}$ " , leaving $\frac{1}{2}$ " of clearance under the side rails of the bed.

START WITH THE CASE

I built the case from $\frac{3}{4}$ " stock with a $\frac{1}{4}$ " plywood bottom. Notice that the back (C) of the case is $\frac{3}{16}$ " narrower than the front (B) to allow for the thickness of the piano hinge.

The bottom (D) fits into a $\frac{1}{4}$ " rabbet along the bottom inside edges of the front (B) and back (C). The box is assembled at each of the corners with woodscrews dressed up with nickel-plated finish washers.

After the box was assembled, I added two cleats (E) to the inside of

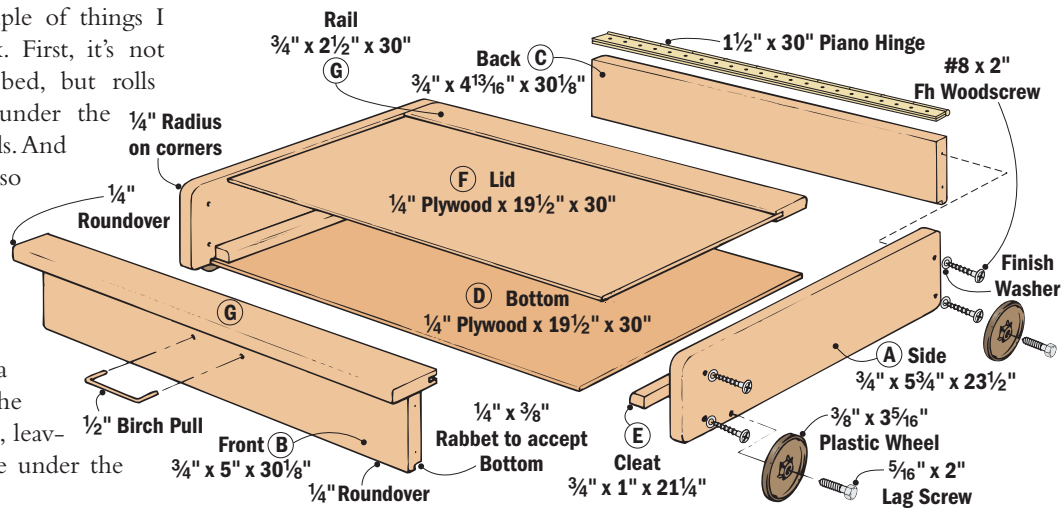

the sides (A). They help support the bottom along the sides (where there aren't rabbets). And they provide additional anchor points for the 2"-long lag screws that act as axles for the wheels.

ADD THE LID

The lid (F) is a $\frac{1}{4}$ " plywood panel that is stiffened by adding rails (G) at the front and back. I found it easiest to glue the lid up while it was sitting on top of the assembled case. That way I was sure it would fit.

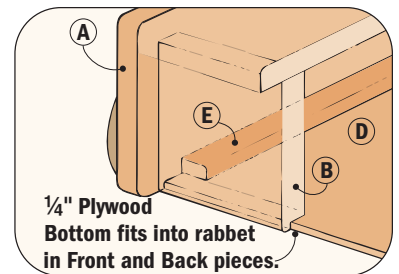

To complete the project, add a drawer pull to the front of the box and attach plastic wheels (see [page 59](#) for sources). Finally, I stained the box to match the bed (see [page 46](#)).

Sources & Resources

WORKBENCH PROJECT KITS

Kits for both the “Heirloom Bed” and the “Under-Bed Storage” projects are available by calling:
1-800-311-3994

You can also order them online at
www.WorkbenchMagazine.com.
 Look for the “Current Project Kits” logo.

Cherry Heirloom Bed – page 38

Cherry Bed Kit \$29.95 – Order No. 3313100-B041

Complete Kit Includes:

- (4) 3/4" x 7" Dowels
- (2) 1/2" x 6" Dowels
- (4) 3"-dia. Hardwood Balls
- (60) #8 x 1 1/2" Fh Woodscrews
- (8) #8 x 2" Fh Woodscrews
- (4) 4" Steel Bed Rail Fastener Sets (8 pieces)

Under-Bed Storage – page 58

Under-Bed Storage Kit \$12.95
 Order No. #3313200-B041-B041

Complete Kit Includes:

- (4) Bed Box Wheels
- (1) 3 3/4" Oak Wire Pull w/screws
- (1) 30" Piano Hinge w/screws
- (2) 5/16" x 2" Lag Screws
- (8) #8 x 2" Fh Woodscrews
- (8) Finish Washers

Research Routers – page 30

Still not sure which router is right for you?
 Continue your research online at these sites.

Porter Cable Corporation

(800) 487-8665

www.PorterCable.com

Craftsman

(800) 349-4358

www.Sears.com

DeWalt

(800) 433-9258

www.DeWalt.com

Bosch

www.BoschTools.com

Skil

www.SkilTools.com

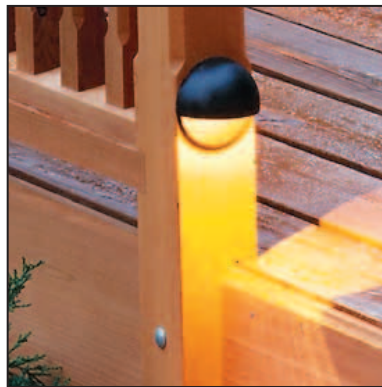

Deck Lighting – page 26

Malibu low-voltage light kit with eight lights. Purchased locally from Home Depot for \$54.98 + tax.

A basic light kit like the one we installed on the newly-refurbished deck on page 26 can make your deck safer after dark. It will also extend the hours you can use it each day.

Router Accessories – page 35



Item description	Jesada (800) 531-5559 www.Jesada.com	Rockler Woodworking and Hardware (800) 279-4441 www.Rockler.com	Woodcraft (800) 225-1153 www.Woodcraft.com	Woodworker's Supply (800) 645-9292	The Woodsmith Store (800) 835-5084
Spiral bits	Yes	Yes	Yes	Yes	Yes
Edge guides	No	Yes	No	No	Yes
Variable speed control	No	Yes	Yes	Yes	Yes
Foot switch	Yes	Yes	No	Yes	Yes
Auxiliary offset base	Yes	Yes	No	No	No
Guide bushings	Yes	Yes	Yes	Yes	Yes
Micro adjustment knob	Yes	No	No	No	Yes
Trammel	No	Yes	Yes	Yes	Yes

Key B041

Wood Conditioner and Stain for Heirloom Bed – page 38

Cherry is the wood of choice for a lot of projects here at *Workbench*. And every time we feature a cherry project, we get the same question from readers: “How can I get a finish like that on cherry?”

Here’s our recipe for an “aged” blotch-free cherry stain: Mix three

parts Zar cherry stain with one part Woodkote Jel’d Cherry. Mix them *very* well. You might want to take them to a paint store and have them shake the mixture. And by the way, before staining the birch finial balls, treat them with a conditioner so they’ll absorb stain

evenly. We used Minwax Pre-Stain Wood Conditioner. For more on these products, visit:

www.Minwax.com

www.Zar.com

www.WoodKote.com



Bright Ideas – page 54

Anxious to shed some new light on your home’s interior? Begin with the article on [page 54](#). Then start designing your own lighting scheme. Here are a few sources for more information:

- American Lighting Association: www.americanlightingassoc.com
- International Association of Lighting Designers www.iald.org
- The Research Center for Lighting Design and Applications: www.lightforum.com
- Manufacturer sites that offer product and dealer information: www.gelighting.com
www.sylvania.com
www.lighting.philips.com
www.progresslighting.com

Keyhole Fittings

– page 50

Keyhole fittings like the ones used to mount the CD shelf on [page 50](#) can be found at most hardware stores.

Here are a couple other suppliers in case you can’t find them locally.

Rockler Woodworking
and Hardware
(800) 279-4441
www.Rockler.com
Product No. 28837

Woodcraft
(800) 225-1153
www.Woodcraft.com
Product No. 125505

Stone Menagerie

Life emerges from stone inside a Chicago craftsman's studio.

For the past 16 years, Terry Arnold has turned huge blocks of limestone and marble into hamburger-gobbling gargoyles, grotesques and other fanciful creatures. "Enough to fill a small ark," he says.

Arnold started carving at age 12, ruining his father's woodworking chisels on chunks of limestone he found in the rubble of demolished buildings. At 20, he became an apprentice in the world-famous marble studios of Pietrasanta, Italy. "I learned the craft from two guys with 110 years carving experience between them and 3rd-grade educations," Arnold says.

Today, his stone fireplaces, fountains and Gothic creatures adorn dozens of gardens, parks and buildings throughout Chicago. One of his most elaborate works, a 9-foot-tall fountain, features three lions spouting water. It took 10 months to carve and assemble the 92 pieces of stone.

To see more of his work, visit www.stonecarver.com.

