

**TOOL TEST:
FINISH
NAILERS**

PRO TIPS for a NO-FAIL FINISH!

WORKBENCH[®]

WOODWORKING TO IMPROVE YOUR HOME

Shaker Table

Two Simple Routing
Techniques Make
It A Snap!



20 UNDER \$20

**WOODWORKING GIFTS
FOR THE HOLIDAYS**

**Classic Oak Bookcase
Built-In or Freestanding**

**ROUTER TABLE
TURNING**

**We Show
You How**

EDITOR'S NOTES

I've always admired homes with built-in furniture. Whether it's a bookcase, display cabinet, or dining room hutch, built-ins always seems to give a room a warm, comfortable feeling.

BUILT-IN BOOKCASES. The built-in bookcases featured in this issue are a good example. They flank the fireplace, which we installed in the first part of our "Fireside Retreat" project for the October 2002 issue of *Workbench*.

One of the appealing things about these bookcases is they look like they've been there since the house was built in the 1920s. Even though the walls weren't square, and they were out of plumb, the bookcases still fit like a nut in a shell. The secret was to follow a few surprisingly simple, custom-fitting techniques that you can use for any built-in project. (To learn more about these techniques, turn to page 19.)

ROUTER TABLE TURNING. There's also another intriguing technique you won't want to miss in this issue. It explains how to "turn" a spindle using a router table and a straight bit. That's right, by using two simple, shop-made jigs, you can make a spindle that looks just like it was turned to shape on a lathe.

SHAKER TABLE. You can put this new technique to immediate use by building the traditional Shaker table

that's featured on page 30. This table is supported by a graceful pedestal that consist of a turned spindle and three arched legs. If you build it out of curly maple like we did, and finish it with one of our favorite finishes (shown on page 44), it's easy to see how this table will become a family heirloom.

20 UNDER \$20. Finally, be sure to check out the "20 Holiday Gift Ideas for Under \$20." Whether you're on the giving, or the receiving end, these gifts are bound to please.

WORKBENCH ON CD. Speaking of gifts, don't overlook our new *Workbench* CD. It includes every tip, Q&A, project plan, tool review, and woodworking and home improvement technique that we featured in 2001.

If you're just getting acquainted with *Workbench*, this CD is an easy way to "tap into" even more hands-on, how-to information. And if you're a long-time *Workbench* subscriber (with stacks of magazines to prove it), it's a great way to get a handle on storing and organizing all of that information.

Plus, you'll find it's very easy to browse this CD. If there's a reference to another article, just click on a "hot" link to go instantly to that article. We've even included links to manufacturers' web sites so you find additional information about their tools and products.

Well, as you can see, I'm pretty excited about this new *Workbench* CD. It's available for \$19.95 by calling 800-311-3994 or you can order online at workbenchmagazine.com.

Tim



Subscription Questions?

Workbench Customer Service
P.O. Box 842
Des Moines, IA 50304-9961
Phone: (800) 311-3991
Online: www.WorkbenchMagazine.com

Editorial Questions?

Workbench Magazine
2200 Grand Ave.
Des Moines, IA 50312
email: Editor@Workbenchmag.com

WORKBENCH

VOLUME 58

NUMBER 6

EDITOR Tim Robertson
SENIOR DESIGN EDITOR Jim Downing
ASSOCIATE EDITORS:
Bill Link, Kevin Shoemsmith, Erich Lage
ART DIRECTOR Robert L. Foss
SR. ILLUSTRATOR/SPECIAL PROJECTS Kim Downing
SENIOR ILLUSTRATORS:
Susan R. Jessen, Mark S. Graves
ILLUSTRATOR/GRAPHIC DESIGNER
Robert McCammon
PROJECT COORDINATOR
Mike Donovan

CREATIVE DIRECTOR Ted Kralicek
SR. PROJECT DESIGNERS Ken Munkel, Kent Welsh
Chris Fitch, Ryan Mimick
SHOP CRAFTSMEN Steve Curtis, Steve Johnson
SENIOR PHOTOGRAPHER Crayola England
ELEC. PUB. DIRECTOR Douglas M. Lidster
PRE-PRESS IMAGE SPECS. Troy Clark,
Minnie Johnson

SUBSCRIPTION QUESTIONS - (800) 311-3991

PRESIDENT & PUBLISHER Donald B. Peschke

GROUP DIRECTOR - MARKETING AND SALES
Fritz Craiger

ADVERTISING SALES MANAGERS
Mary K. Day (515) 875-7200
George A. Clark (515) 875-7100
ADVERTISING COORDINATOR
Nicolle Carter (515) 875-7135



WORKBENCH (ISSN 0043-8057) is published bimonthly (Feb., April, June, Aug., Oct., Dec.) by August Home Publishing Company, 2200 Grand Ave., Des Moines, IA 50312. *Workbench* is a trademark of August Home Publishing. Copyright ©2002 August Home Publishing Company. All rights reserved.
Subscription rates: Single copy, \$4.99. One-year subscription (6 issues), \$22; two-year sub., \$33; three-year sub., \$44. Canadian/Int'l. add \$10 per year. Periodicals postage paid at Des Moines, Iowa, and at additional offices.
"USPS/Perry-Judd's Heartland Division automatable poly"
Postmaster: Send address changes to *Workbench*, PO Box 37272, Boone, IA 50037-0272.
Printed in U.S.A.

AUGUST HOME PUBLISHING COMPANY Corporate Services:
Corporate Vice Presidents: Douglas L. Hicks, Mary R. Scheve, Controller: Robin K. Hutchinson, Senior Accountant: Laura J. Thomas, Accounts Payable: Mary J. Schultz, Accounts Receivable: Margo Petrus, Production Director: George Chmielarz, System Administrator: Cris Schwanebeck, PC Maintenance Technician: Robert D. Cook, New Media Manager: Gordon C. Gaippe, Web Site Art Director: Eugene Pedersen, Web Designer: Kara Blessing, Web Server Administrator: Carol Schoeppler, Web Site Content Managers: David Briggs, Sue M. Moe, Professional Development Director: Michal Sigel, Human Resources Assistant: Kirsten Koeke, Office Manager: Noelle M. Carroll, Receptionist: Jeanne Johnson, Mail/Delivery Clerk: Lou Webber • Circulation: Subscriber Services Director: Sandy Baum, New Business Director: Wayne J. Klingbeil, Multi-Media Promotions Manager: Rick Jenkins, Renewal Manager: Paige Rogers, Billing & Collections Manager: Rebecca Cunningham, Circulation Marketing Analyst: Kris Schlemmer, Associate Circulation Marketing Analyst: Paula M. DeMatteis, Promotions Analyst: Patrick A. Walsh • Creative Resources: Associate Editor: Craig Rueggeger, Assistant Editors: Joseph E. Irwin, Joel Hess, Art Director: Douglas A. Flint, Senior Graphic Designers: Chris Glowacki, Mark Hayes, Robin Friend, Graphic Designer: Vu Nguyen • Products Group: Operations Director: Bob Baker, Customer Service Manager: Jennie Enos, Warehouse Supervisor: Nancy Johnson, Buyer: Linda Jones, Administrative Assistant: Nancy Downey, Technical Service Representative: Johnny Audette, Customer Service Team Leader: Tammy Truckenbrod, Senior Customer Service Representatives: Anna Cox, April Revell, Customer Service Representatives: Deborah Rich, Valerie Jo Riley, Eddie Arthur, Warehouse Staff: Sylvia Carey, Sheryl Knox • Woodsmith Store: Manager: Dave Larson, Assistant Manager: Tim Thelen, Sales Staff: Wendell Stone, Jim Barnett, Mark Johnson, Gregory Kauzlarich, Shipping and Receiving: Larry Morrison, Office Manager: Vicki Edwards



Contents

WORKBENCH®

December 2002

FEATURES

19

Built-in Bookcases & More

We put the finishing touches on our "Fireside Retreat" with built-in bookcases and solid oak trim.

28

Classic Oak Bookcase

A few small changes is all it takes to convert the built-in bookcase to a freestanding unit.

30

Shaker-Style Pedestal Table

Just follow our simple steps to success to build your own family heirloom.

40

Router Table Turning

Discover a unique routing technique that makes it easy to "turn" a spindle — without a lathe.

44

Fancy Finish for Figured Maple

Make your next figured maple project come to life with this special 3-part finishing technique.

46

Tool Review: Finish Nailers

We put eight pneumatic finish nailers on the firing line to find out which one is best.

60

20 Great Gifts Under \$20

Here are 20 great stocking stuffer ideas for the woodworker on your holiday shopping list.

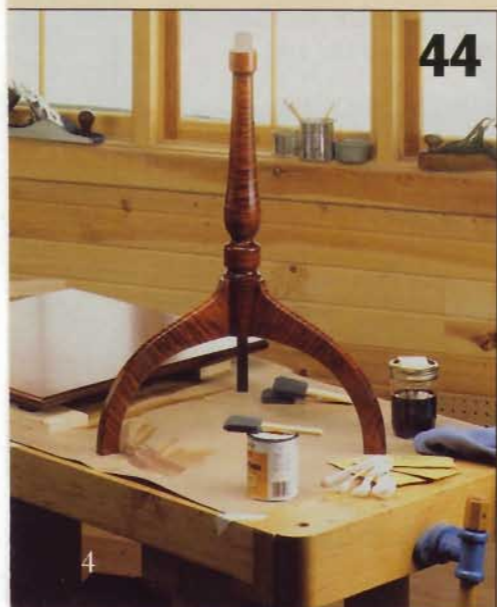
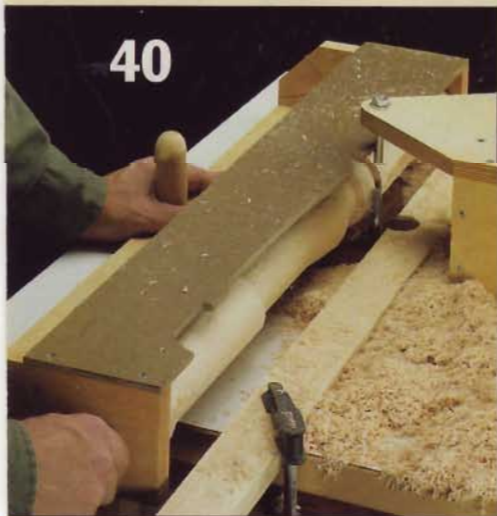

DEPARTMENTS

Questions & Answers	8
Tips & Techniques	14
In the Shop	56
Tools & Products	66
Craftsmanship	82



Questions & Answers

Rating the Hardness of a Chisel

Q I'm shopping for a new set of chisels, and I keep hearing about the Rockwell Scale. What exactly is it? And is it really that important?

Terri Obermeier
Green Bay, WI

A The Rockwell Scale is a method of describing the hardness of metal developed in conjunction with the American Society for Testing and Materials (ASTM). It is the most often-used measurement of metal tool hardness in the world today.

Most tool manufacturers give the hardness of their blades in numerical figures followed by the letters "Rc," which stands for "Rockwell c." To test the hardness of a particular blade using the Rockwell Scale, a metal cone made from a Brazilian diamond termed a "Conical Brale" (hence the c) is pressed into the metal being tested. The Rockwell hardness is defined at the point of deformation or penetration into the metal. The higher the numerical designation, the harder the metal. So a chisel with a Rc60 is harder than an Rc55.

Is it important to know this rating? You bet. The hardness of a chisel directly affects its ability to hold an edge and its overall performance. The harder the tool, the longer the edge lasts. But when you're comparing chisels, keep in mind that hardness is also proportional to brittleness. The harder the blade, the easier it chips. So it's often a compromise between hardness and brittleness.

Some older tools made from high carbon steel (and many Japanese chisels) may be rated as high as Rc66. In general, however, chisels made with steel tested at Rc58 to Rc62 should perform well. They also keep their edge for a reasonable time before they need to be sharpened.



This Pfeil Swiss-made chisel has a hardness rating of Rc61

This Marples Blue Chip chisel has a hardness rating of Rc62

This Japanese Iyori chisel has a hardness rating of Rc62

Secret Strength of a Cement Board Screw

Q I noticed you used cement board screws to install the underlayment for the ceramic tile on the fireplace hearth (October 2002, page 22). What's the difference between these screws and drywall screws?

Garrett Lazarus
Minneapolis, MN

A There are three main differences between a cement board screw and a drywall screw. All of these differences are designed to help the cement board screws penetrate and hold in hard material.

SPLIT TIP. Part of the tip of a cement board screw is split to create an angled point

(see Cement Board Screw at right). This sharp tip lets the cement board screw penetrate rock-hard material without having to pre-drill.

THREADS. Notice, too, how a cement board screw has two rows of threads instead of a single thread like a drywall screw. The fine thread is designed to pierce the cement board quickly. The second thread is larger to provide extra holding power.

HEAD. The third difference is in the heads. Instead of a smooth flared head like on a drywall screw, a cement board screw has small "nibs" underneath. These nibs actually cut a countersink for the head, so there's no need to drill a separate countersink.

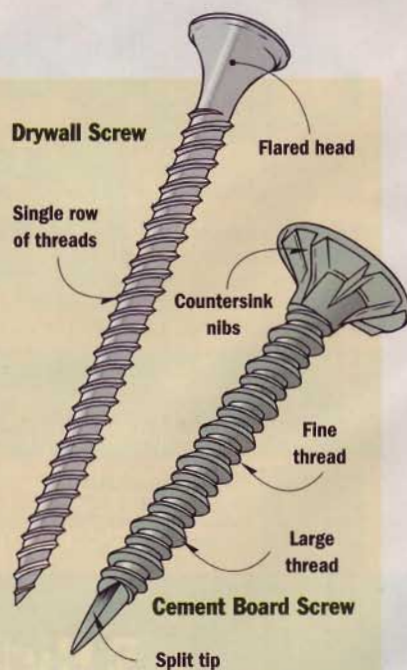

MORE PRESSURE EQUALS BETTER PERFORMANCE

Compressor Comparison	CRAFTSMAN®	CAMPBELL HÄUSFELD®	PORTER CABLE®
	150 PSI (30 Gal.)	130 PSI (30 Gal.)	135 PSI (25 Gal.)
Operating Time (seconds)			
3/8" Air Ratchet	71	33	48
3/8" Drill	59	25	39
Random Orbit Sander	65	29	43
1/2" Impact Wrench	65	29	43
Number of Roofing Nailers (60 nails each)	5	3	4

Actual performance may vary on a unit-to-unit test.

Just \$329.99

Ask for #16731
Hose and tools sold separately

Available at Sears and
Sears Hardware stores

800.437.9686

www.sears.com/craftsman

SEARS
Where else?™

© 2002 Sears, Roebuck and Co.

Less Filling, Expands "Great"

Q In the October 2002 issue of *Workbench*, you recommended insulating between window jambs and wall framing with either fiberglass or spray foam. But the sales representative at a window store told me not to use expanding foam because it causes problems. What's up?

Andrea Proctor
Aurora, IL



A Many window manufacturers will void their warranties if you use expandable polyurethane foam to seal between the window jamb and the frame. That's because the pressure the foam exerts as it expands can bow the window jambs and prevent the window from operating properly.

What you want to use is a *low-pressure foam* like the foam shown above called Great Stuff. It's designed specifically for use with windows. This foam insulates and seals gaps, and it prevents moisture damage to the window.

Count on Coins

Q I've heard about using a penny to lay out a $3/8$ " radius. Do other coins make good measuring devices, too?

Sam Hattering
Via the Internet



A I've been known to pull a coin out of my pocket on occasion to mark a rough circle or a radius, especially when precision isn't all that critical.

For example, you're right about the penny. It does have a $3/8$ " radius, as shown in the Photo above. A quarter comes in handy for marking a $1/2$ " radius. And if you need a makeshift tape measure, grab a dollar bill. It's approximately 6" long and $2 1/2$ " wide.

You Have QUESTIONS... We Have ANSWERS!

Looking for basic helpful hints or good common-sense solutions to everyday woodworking and home improvement problems? If so, send us your best questions. We're happy to share the tips, tricks, and great woodworking ideas we've collected over the years.

HOW TO SEND YOUR LETTER:

Email: editor@workbenchmag.com

Forums: www.forum.woodnet.net

Mail Carrier: Workbench Q&A, 2200 Grand Ave.,
Des Moines, IA 50312

Please include your name, address, and phone number. If we publish your letter, you'll receive this handsome and fashionable *Workbench* cap.

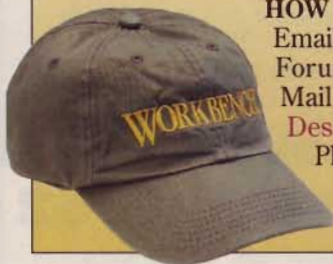

Tips & Techniques

FEATURED TIP

End Boring Made Easy

Drill presses really aren't designed for boring holes in the end of a long board. So I built a table for my drill press that makes end boring easy.

The L-shaped table and triangular support brackets are made from plywood (see below). The top of the table lets you clamp it to the drill press table, while the two holes in the side are for clamping a fence that's used to align the workpiece. The curved notches in the brackets straddle the arm of the drill press from either side. When setting, swing the table to one side and lock it in place. Then clamp the fence and workpiece perpendicular to the table. Now bore the hole (see photo).

Scott Vanderhart
Russells, IA

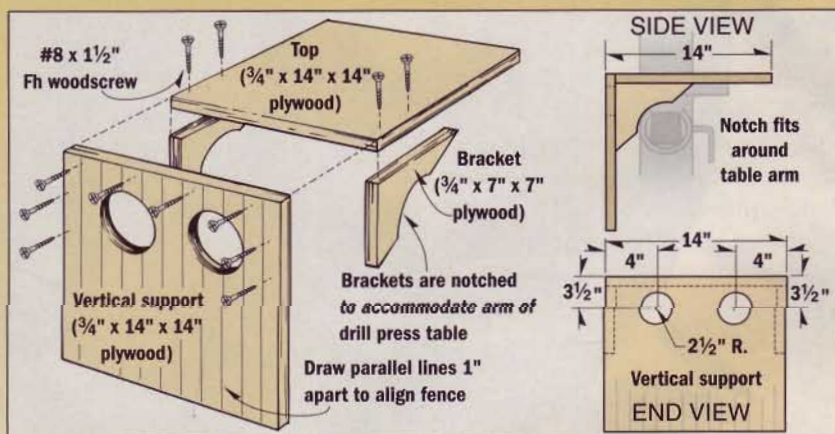

▲ Pencil lines on the side of the table are handy for aligning a fence that holds the workpiece perpendicular to the drill press table.

Rafter Pattern

When framing a roof, the rafter length, the angles of the ridge and eave cut, and the bird's mouth must be identical on all rafters. Making a "pattern" rafter to ensure consistency is an old trick, but one I've improved on.

I tack a couple of cleats to the pattern rafter (see below). With the

cleats butted against the workpiece, it's easy to trace the pattern on each rafter. And it prevents me from accidentally sending up the pattern rafter by mistake.

Cindy McGaha
Russell Springs, KY

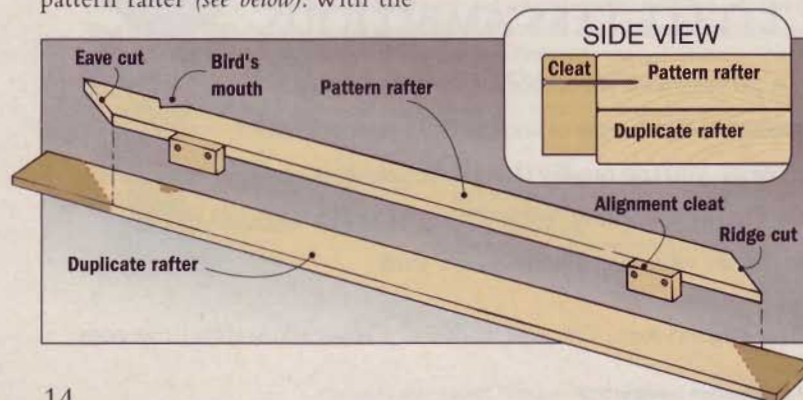

TOOLS FOR TIPS!

SHARE YOUR TIPS, JIGS & IDEAS

This issue's Featured Tip winner receives this Craftsman Laser Trac Radial Arm Saw!

Do you have an original shop or home improvement tip to share with other *Workbench* readers? Just write down your tip and mail it to:

Workbench Tips & Techniques
2200 Grand Ave.
Des Moines, IA 50312

Please include your name, address, and daytime phone number. Or if you prefer, email us at: Editor@Workbenchmag.com



Towel Bar Mounting Cleat

The ends of a towel bar often don't line up with studs, which makes it difficult to mount the bar securely to the wall. My solution is to install a 1x4 "backer" in the wall cavity where the mounting bracket will be located. This makes for a solid stud-like mounting surface (see illustration).

To do this, cut a hole in the drywall large enough for the backer. Then attach a string to the backer and slip it into the opening. Pull the string tight to hold the backer against the drywall. Then fasten the backer by screwing through the drywall. Once the hole is patched, taped, and "mudded," screw the mounting plate to the backer.

Robert Buehler
Overland Park, KS

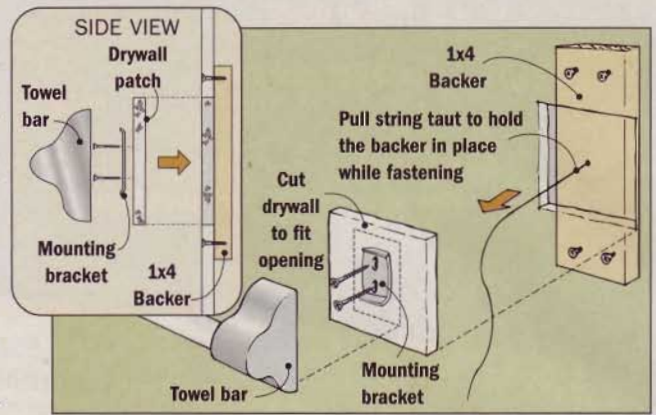

Drop-dead gorgeous.

Incredibly well built.

A pleasure to hold.

And available.



W.R. CASE & SONS CUTLERY CO.
HAND-CRAFTED KNIVES SINCE 1889

Find your nearest Case dealer at www.wrcase.com or call 1-800-523-6350.

Clamp Storage

I have quite a few of the one-handed, fast-action clamps. To keep them organized and within easy reach, I clamp them to a scrap piece of metal angle that's screwed to a ceiling joist (see below).

Ian Stewart
Toronto, Ontario

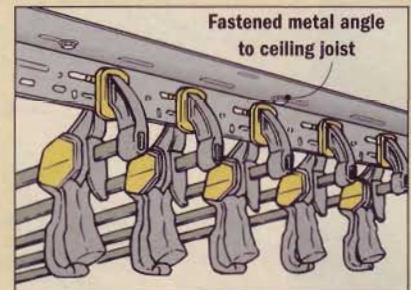

Caulking Conservation

I rarely use a whole tube of caulking at one time. So, to keep the tube from drying out after I'm done caulking, I tap the base of the tube on the bench to settle the caulk back down in the tube. Then I insert the cutoff tip into the nozzle of the tube and tape it in place (see below).

Glenn Kaszubski
Liquid Nails Corporation



Fireside Retreat — Part 2

Built-In Bookcases



When we featured the “Fireside Retreat” in the October 2002 issue of *Workbench*, our goal was to create a focal point in an ordinary-looking living room. Installing a fireplace, ceramic tile hearth, an oak mantel, and leaded glass windows would have accomplished that all by itself. But we wanted to take it a step further.

So for this second part of the project, we installed a built-in bookcase on each side of the fireplace. Although the bookcases are easy to build, they do present a bit of a problem when it comes to fitting them into openings where the walls aren’t square or plumb (which usually seems to be the case).

FACE FRAME FIRST. The solution was to build only the face frame of the bookcase to fit the opening. The case itself is smaller to accommodate the irregular walls. Of course, this creates gaps between the case and the walls, but they’re completely covered by the face frame. The result is a built-in piece of furniture that looks like it has been there since the house was built.

FREESTANDING BOOKCASE. Having said that though, you don’t *have* to build this bookcase into your house. It also makes an attractive freestanding unit. All it takes is a few minor modifications, as explained on page 28.

TRIM & CASING. There’s one last thing worth mentioning about this project. To tie it all together visually, we installed solid-oak trim and window casing. Be sure to check out our technique for installing the window casing. Besides providing a professional-looking installation, this technique guarantees that the miter joints on the casing won’t separate.

BUILT-IN BOOKCASES

The challenge with the two built-in bookcases is to make them actually look built-in — not just slid into the opening between the wall and the fireplace chase (*Construction View*). That requires custom fitting.

The secret is to make the case smaller than the opening, and then custom fit *only* the face frame to the

opening (*Face Frame Top Section View*). That's done by scribing one side of the frame and adding a filler strip to the other (*Filler Strip Detail*).

SIZING THE FACE FRAME. But first, you need to determine the size of the face frame. That depends on two things: the width of the opening and the height of the mantel.

The width is the tricky one. It's important that the face frame fit within the narrowest point of a plumb opening. You can see how I worked that out in *Determining the Face Frame Width* on page 21.

To establish the height of the face frame, simply measure from the floor to the bottom of the mantel. The

ONLINE Extras
Fireside Retreat (Part 1). Includes installation of a direct-vent fireplace, ceramic tile hearth, & oak mantel.
WorkbenchMagazine.com

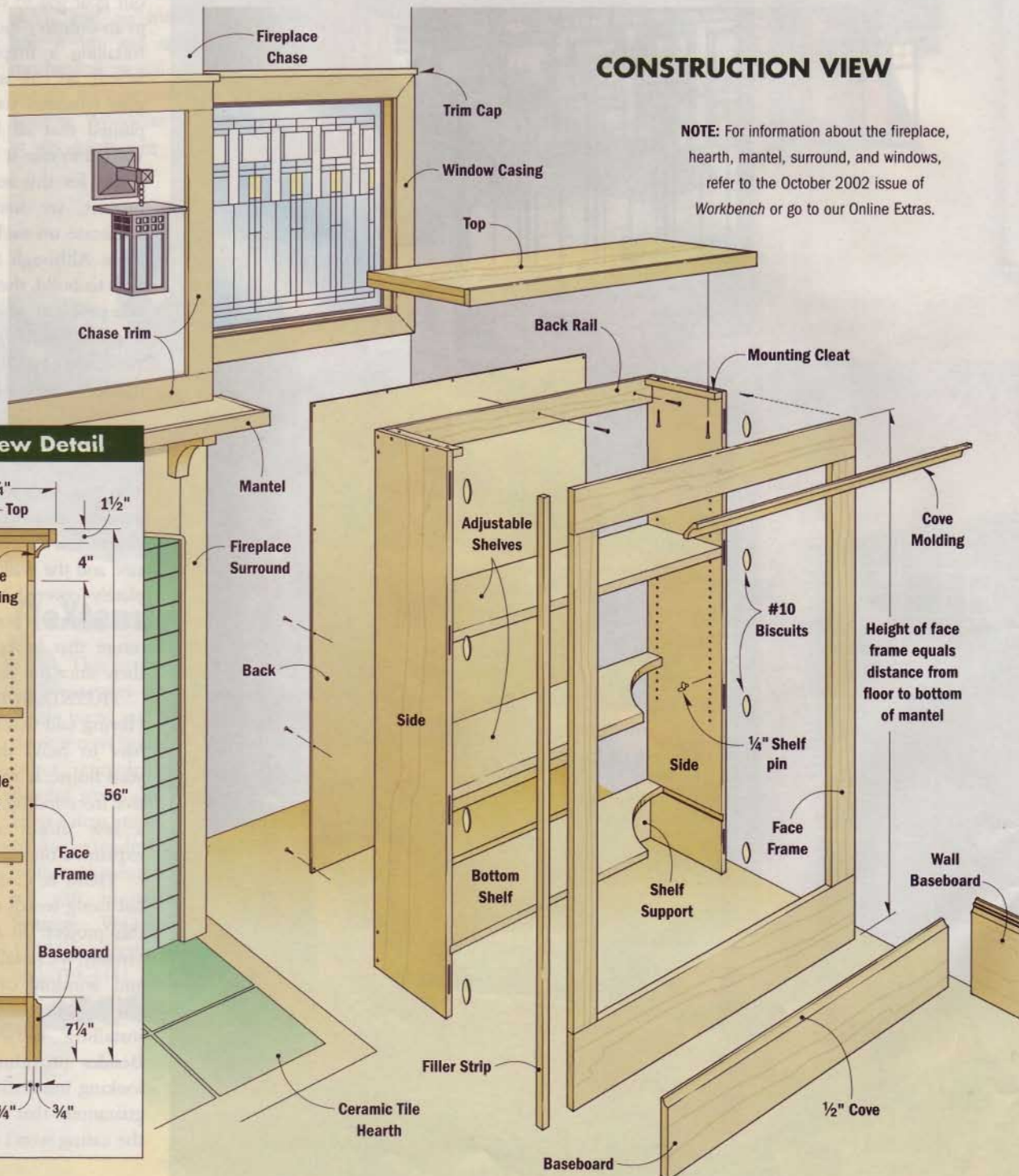

top of the bookcase will be at the same height as the mantle, so that's all the reference you need.

BUILD THE FACE FRAME. Once you've determined the dimensions, you can start on the face frame. Notice in the *Face Frame Assembly* illustration that it's made up of a

wide bottom rail (A), a narrow top rail (B), and two vertical stiles (C). After cutting the pieces to size from $\frac{3}{4}$ "-thick hardwood (quartersawn red oak), I assembled them with biscuit joints, using a single #10 biscuit at each joint. (See page 58 for tips on clamping up a large face frame.)

FACE FRAME ASSEMBLY

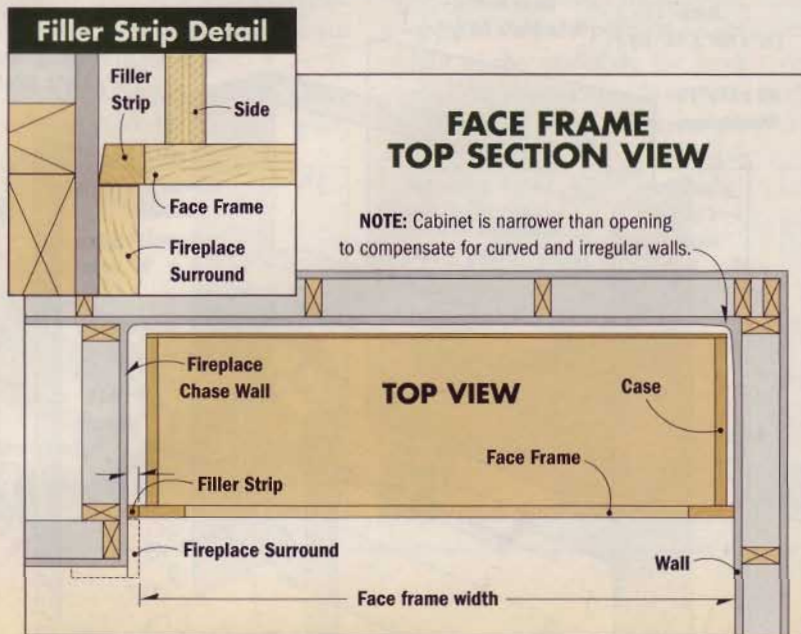
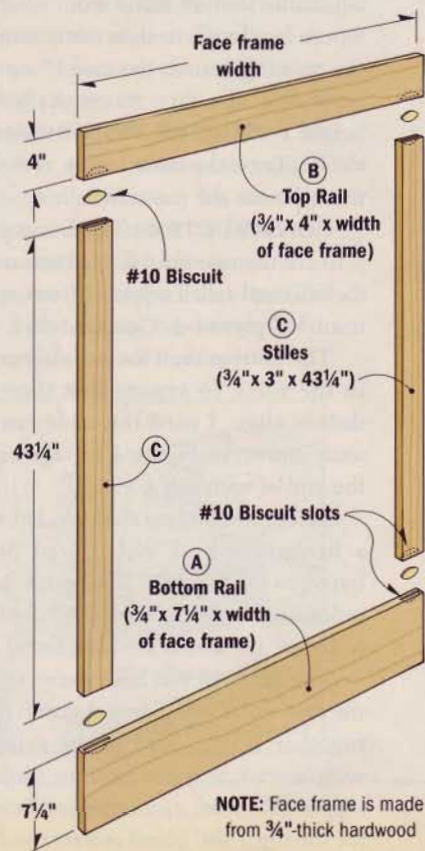

DETERMINING THE FACE FRAME WIDTH

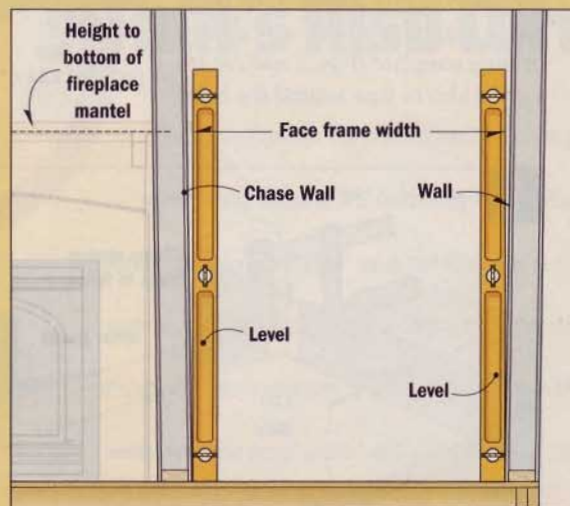
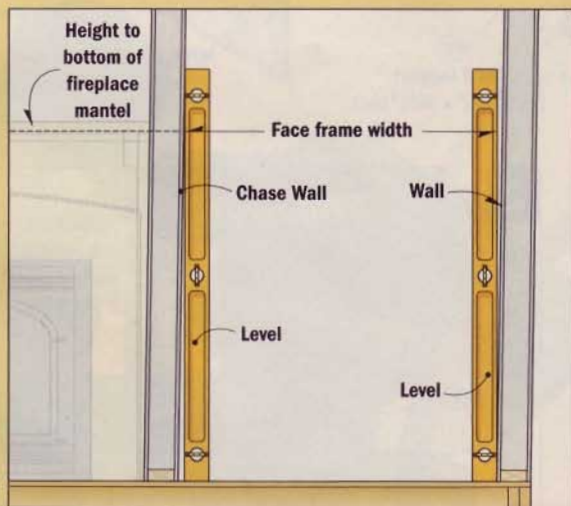

The face frame you build will be square. The opening it goes in may not be. So the face frame is built to fit inside the narrowest point of the *plumbed* opening. Above are two examples of how an opening can be out of plumb. You

can see how I used two levels to "create" a plumb opening. Think of the levels as representing the stiles in the face frame and you'll understand how this works. Just be sure to measure to the *outside* of the levels.

build the case

The case is a plywood box with two adjustable shelves made from solid wood. To allow it to slide easily into the opening, I made the case 1" narrower than the face frame. As for height, it's 54½" tall. This will make the bookcase the same height as the mantel once the top is installed.

CONSTRUCTION. The first step is to cut the two sides (D), a bottom shelf (E), and a shelf support (F) to size from ¾" plywood (*Case Assembly*).

The bottom shelf fits into dados in the sides. To ensure that these dados align, I used the table saw setup shown in Figure 1 to register the end of each side panel.

Before assembling the case, I cut a hardwood back rail (G) to fit between the sides. It creates a mounting surface that will be used to secure the bookcase to the wall.

The back rail will help square up the case while you glue and clamp it together. It's fastened to the sides with screws, as is the bottom shelf support. To create a mounting surface for the top, I also glued and screwed a hardwood cleat (H) to each side.

SHELF PIN HOLES. The next step is to drill holes in the sides for shelf pins that support the adjustable shelves. A handy way to keep these holes aligned is to use a pegboard drilling template (*Figs. 2 and 2a*). It's a good idea to tape around the holes

you plan to use to avoid confusion. Also, orient the template the same way on both sides — with the bottom edge down and the front edge flush with the case.

ADD A BACK. After drilling the holes, the next step is to add the back (I). It's just a piece of ¼" oak plywood that's cut to fit and then screwed in place.

CASE ASSEMBLY

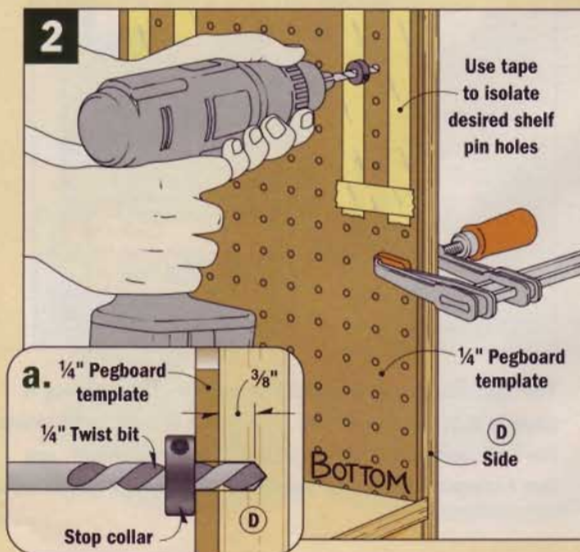
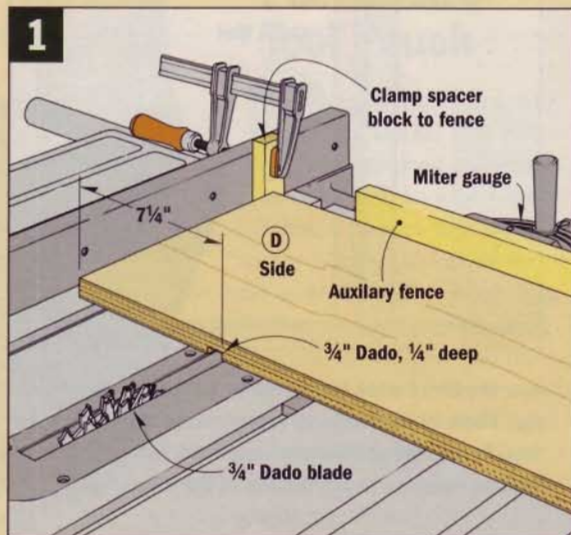
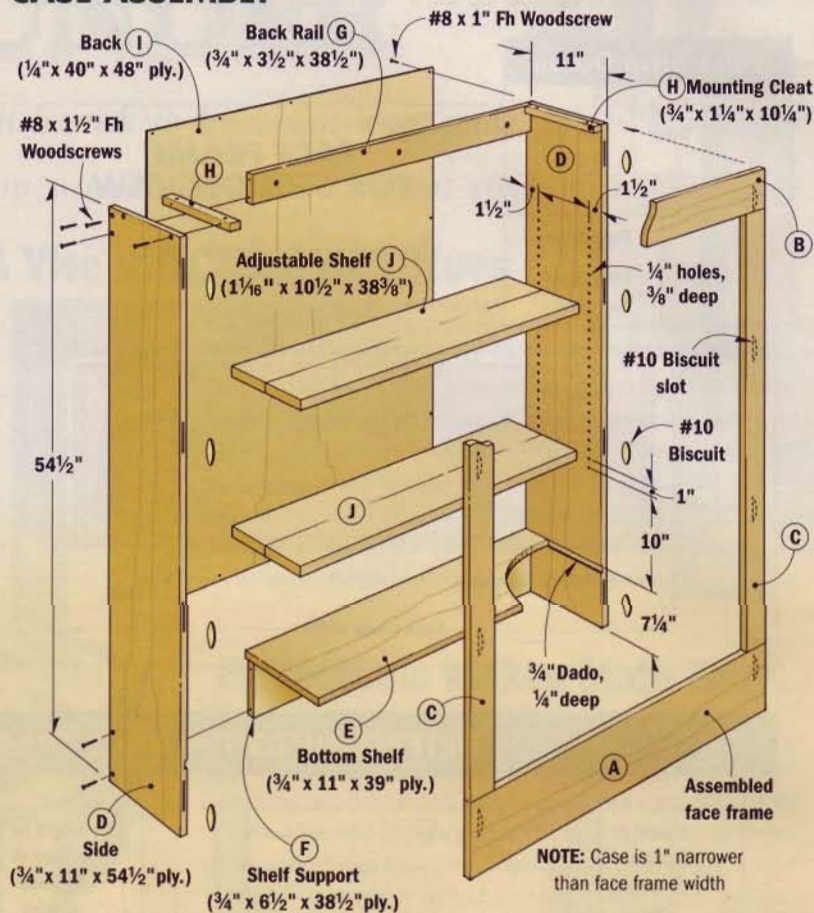

ADJUSTABLE SHELVES. With the case this far along, now is a good time to build the adjustable shelves (J). Unlike the bottom shelf, there's no additional support for the adjustable shelves. So to prevent them from sagging, I made each shelf from 1 1/16"-thick hardwood boards that are edge glued together.

ATTACH FACE FRAME. At this point, you're ready to add the face frame. It's attached with biscuits that fit into slots in the front edge of the case and the back of the face frame.

One thing to pay attention to here is the location of the slots in the face frame. To fit the face frame to the walls, it overhangs each side of the case by 1/2". This means that the slots in the face frame need to be offset by that same amount (1/2").

To create the proper offset, I used a 1/2"-thick scrap piece of wood as a spacer when cutting the slots in the case (Photo a). The spacer is cut to length to match the height of the case. After laying out the slot locations on the spacer and the face frame, clamp it to the case and cut

the slots, as shown. Then, without changing the fence setting on the plate joiner, cut matching slots in the face frame (Photo b).

FIT THE FACE FRAME. After gluing and clamping the face frame to the case, it's time to fit it to the walls. The first step in this process is to slide the case into the opening and then scribe a line on the face frame that "follows" the contours of the wall. To do this, I used a scrap block with a notch for a pencil (Fig. 3). By sliding the scrap against the wall, you can draw a line that matches the wall perfectly. Then plane to the line to custom fit the face frame (Fig. 4).

FILLER STRIP. To fit the other edge of the face frame against the wall, it's easiest to use a filler strip (I). The filler strip is sized to match the gap between the wall and the face frame (Filler Strip illustration).

To make the filler strip, measure the gap at the top, middle, and bottom, and then transfer these measurements to a wide blank (Fig. 5). To create a tight fit, tilt the base of the jig saw and back-cut the filler strip,

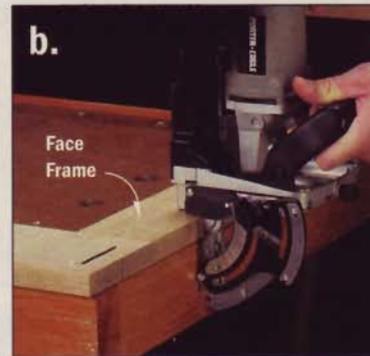

◀ With a 1/2"-thick spacer board clamped to the case, set the fence on the plate joiner to cut slots centered on the thickness of the side.

◀ Using the same fence setting, but without the spacer, cut the matching biscuit slots in the back of the face frame.

as shown in Figure. 5a. Then simply glue the filler strip in place.

INSTALL CASE. Finally, slide the case into the opening, shim it level if necessary, and screw it to the wall.

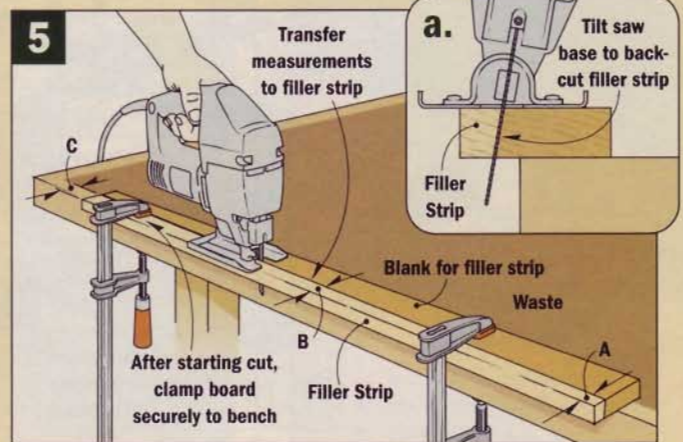
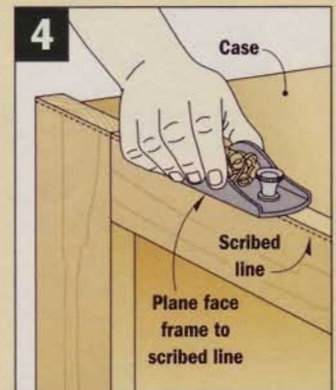
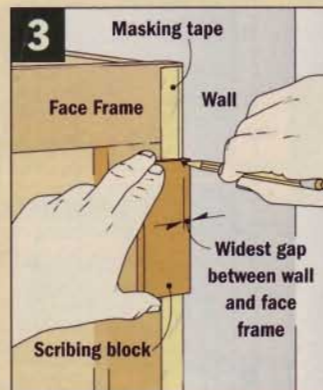
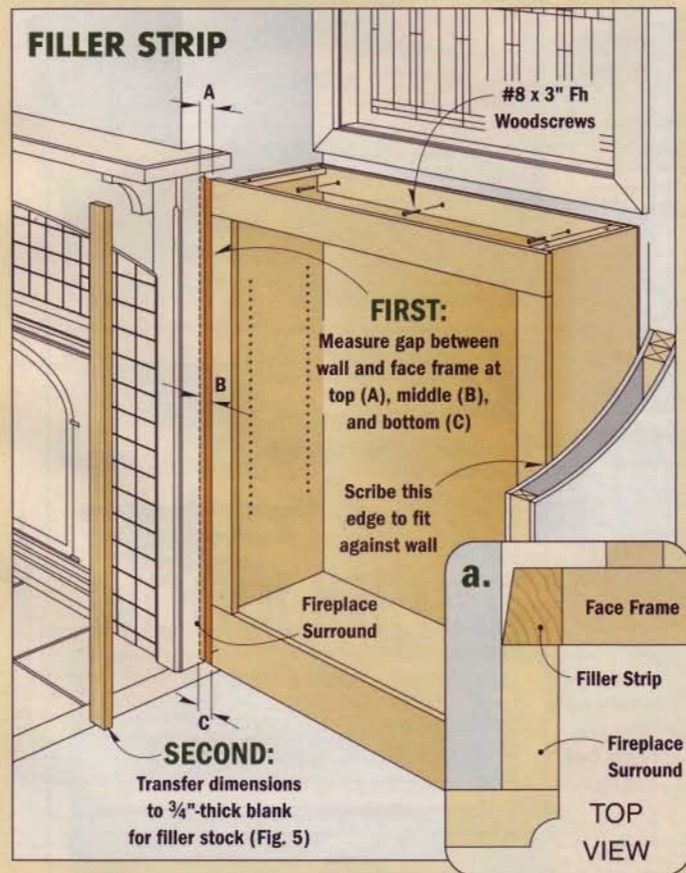

bookcase top & cove molding

To cap off the bookcase, I added a thick top and some cove molding (*Top Installation*). Here again, a “build-to-fit” technique will ensure a professional-looking installation.

LAMINATED TOP. The top (K) consists of two $\frac{3}{4}$ " plywood panels glued face to face. These panels will shift a bit when you clamp them together, so it's best to start with oversize pieces and trim them to final size later. I cut the panels 1" longer than the width of the opening and 1" wider than the finished width of $13\frac{1}{2}$ ".

MAKE IT FLAT. When gluing up the panels, it's important to end up with a *flat* top. Even a slight bow will be fairly noticeable. So I made a couple of 2x4 clamping cauls to “press” the panels flat (*Fig. 6*). Just be sure the 2x4s are straight. Also, it's a good idea to joint the edge of each caul that bears against the panels.

GLUE-UP. Now you're ready to glue the panels together. I'd suggest using a roller to apply glue to a large area like this. Then “sandwich” the panels between the cauls and tighten the clamps.

Before the glue dries, make it a point to check that the long edge of one panel completely overhangs the other. This overhang forms a continuous straight edge that you can set against the rip fence when trimming the front edge of the top (*Fig. 7*).

Notice that only the *front* edge is trimmed at this point. The back edge, and both ends of the top, need to be custom fit to the opening.

MAKE A TEMPLATE. An easy way to accomplish that is to make a paper template that matches the variations in the walls. This is just a piece of cardboard with 3x5 index cards taped to it (*Fitting the Top*).

To make the template, cut the cardboard smaller than the opening

and then tape it flush with the front of the bookcase (*Fig. 8*). Then fit the index cards against the walls, one at a time, taping them to the cardboard as you work your way around.

The next step is to transfer the shape of the template to the top. To do that, carefully remove the template from the bookcase and tape it to the top, flush with the front edge (*Fig. 9*). Then trace around the template as shown.

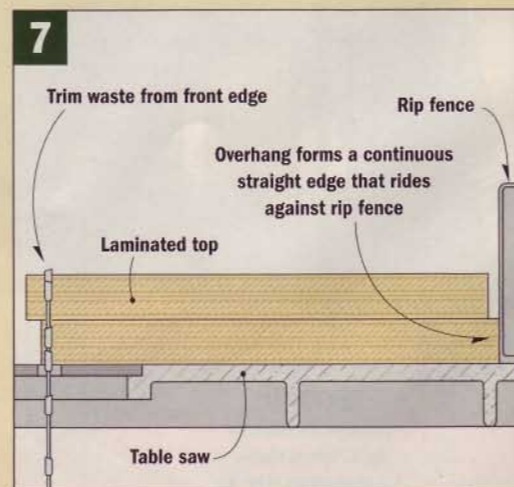
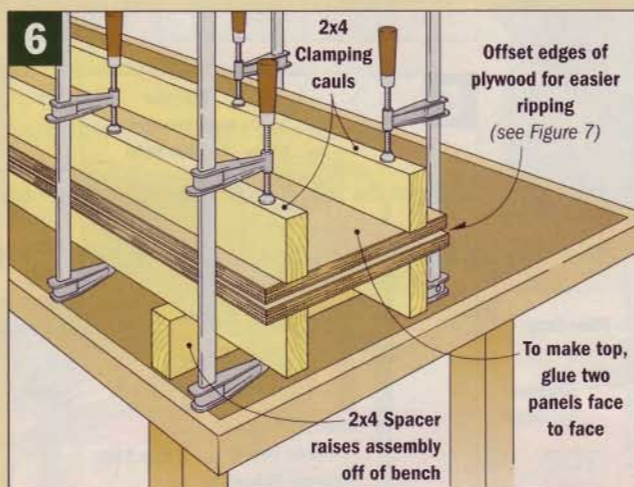
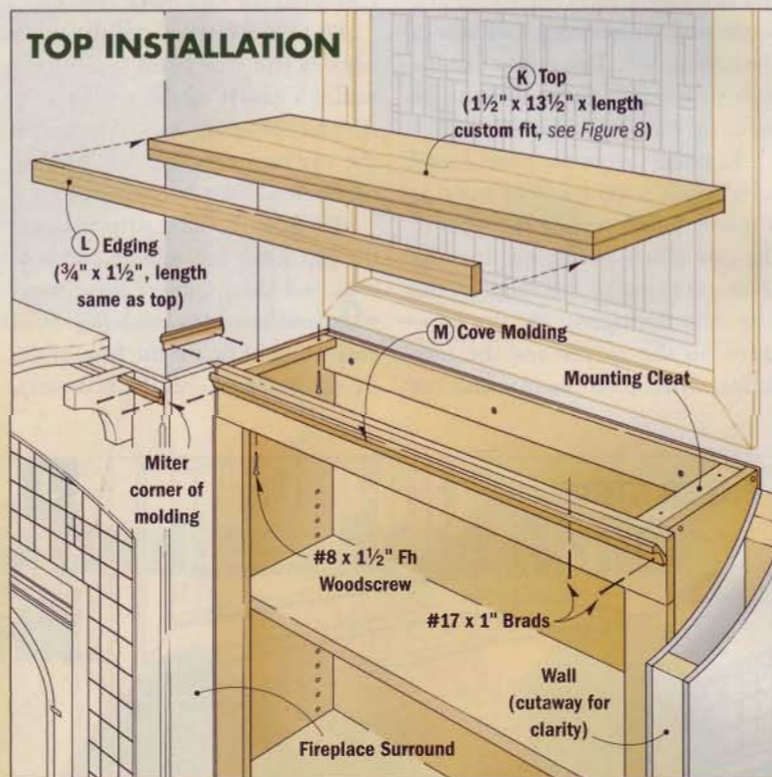

To cut the top to shape, I used a jig saw with the base tilted at an angle (Fig. 9a). This forms a slight back-cut, which should create a tight fit where the top edge meets the wall. To check, slide the top into position, examine the fit, and make any adjustments that are needed.

EDGING. Once you're satisfied with the fit, the next step is to cover the exposed front edge with solid wood edging (L). This is a strip of $\frac{3}{4}$ "-thick oak that's cut to length to fit between the walls. To install the edging, remove the top, and then glue and clamp it to the front edge.

The edging needs to be sanded flush with the surface of the plywood. Be

careful here, you don't want to sand through the thin veneer. I used a nifty, shop-made sanding block to prevent that from happening (page 56).

INSTALL TOP. At this point, it's just a matter of reinstalling the top and screwing it to the mounting cleats in the case.

COVE MOLDING. To complete the bookcase, I installed cove molding (M) under the top and around the corners of the chase (Top Installation). This required mitering the ends of the moldings.

The trick to making accurate cuts is to use a miter saw with a special set up. The reason for the setup is to hold the molding at the same angle it will ultimately be installed. For this molding, that means that the "flats" on the back rest against the fence and the table of the saw (Figs. 10 and 10a). Note: Set the bottom of the molding against the fence.

To prevent the molding from slipping, I attach a scrap block to the saw table with carpet tape.

Now, to cut the inside miter, rotate the saw 45 degrees to the left, set the molding in position, and miter the end. For the outside corner, adjust the saw setting to 45 degrees to the right and cut the molding in the same manner.

Finally, to complete the installation, simply nail the moldings in place.

FITTING THE TOP

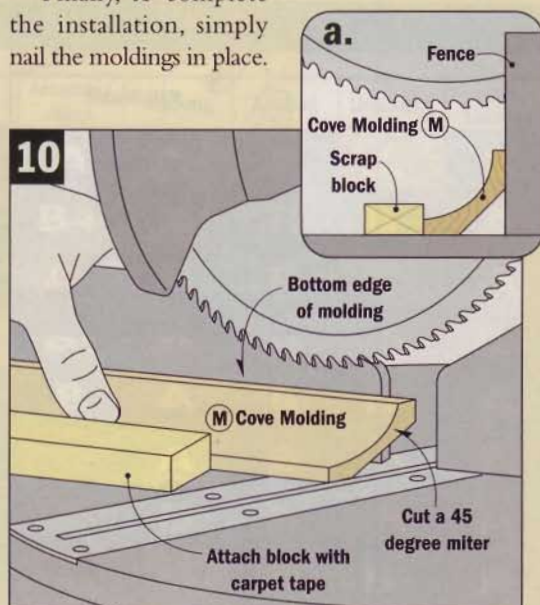
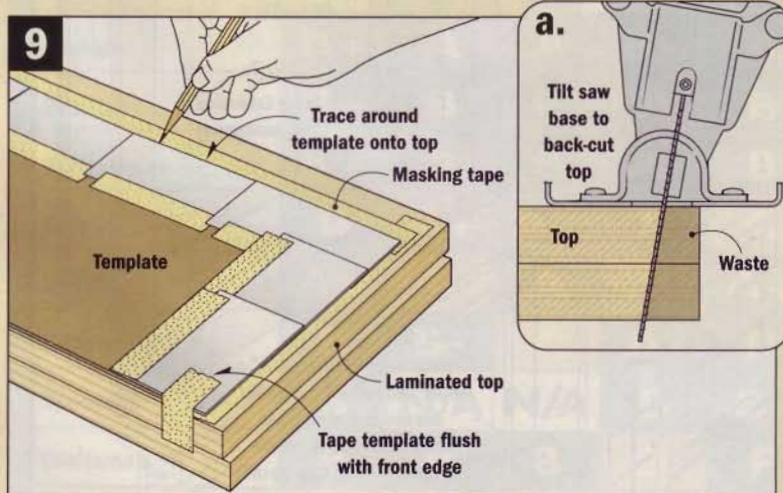
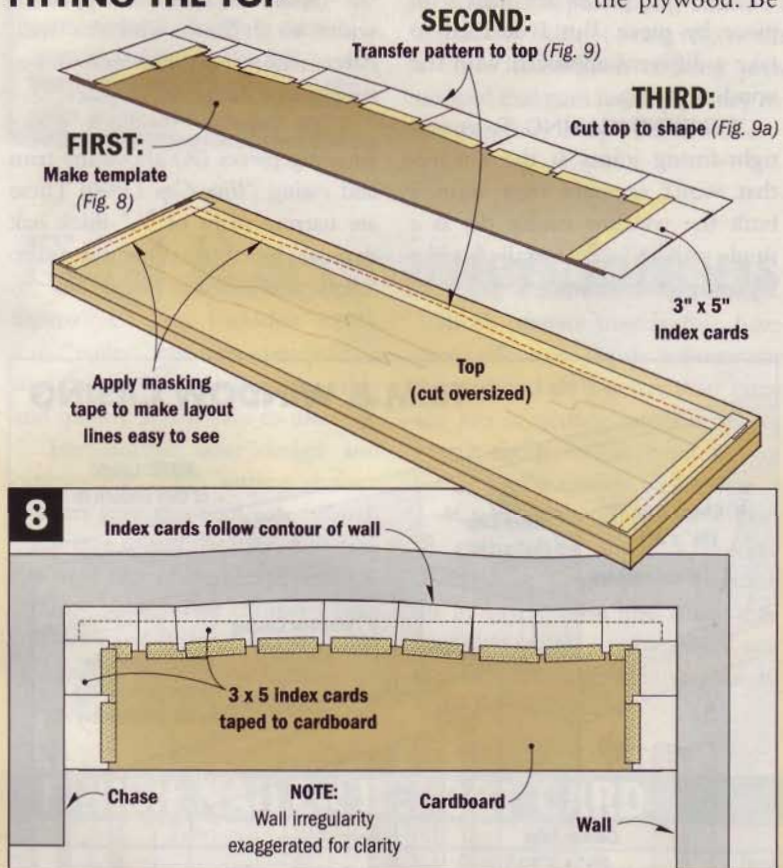

install trim & window casing

To complete this fireside retreat, I "wrapped" the chase with solid-oak trim (N, O), installed window casing (P), and added trim cap pieces (R) (*Trim and Window Casing*).

TRIM. In keeping with the Craftsman style of the house, I wanted to use the trim to create strong horizontal and vertical lines. Notice how it aligns with the window casing, forming a continuous horizontal band across the wall. The corner and back chase trim "mirror" the vertical members of the casing.

All of the trim pieces (N, O) are $\frac{3}{4}$ "-thick oak boards that are ripped to width. I mitered the horizontal pieces to fit around the chase. As for the corner trim, it's made up of two boards that are bevel ripped to width, cut to length to fit between the horizontal pieces, and assembled with glue and biscuits (*Corner Trim Detail*).

The trim pieces are nailed on piece by piece. But I decided to take a different approach with the window casing.

WINDOW CASING. To ensure tight-fitting joints at the corners that won't separate over time, I built the window casing (P) as a single unit and then installed it like a giant picture frame.

The frame for the window casing is assembled with miter joints that are strengthened with biscuits (*Window Casing Detail*). Notice that it's sized to create a $\frac{1}{4}$ " reveal between the frame and the jamb extensions of the window.

Speaking of window jambs, I had to add extensions (Q) to mine. These jamb extensions are strips of $\frac{3}{4}$ "-thick oak that are ripped to width to fit flush with the wall. After nailing on the extensions, simply nail the frame in place.

CAP PIECES. Finally, I added trim cap pieces (R) above the trim and casing (*Trim Cap Detail*). These are narrow strips of $\frac{3}{4}$ "-thick oak that are ripped to width, mitered to length, and nailed in place.

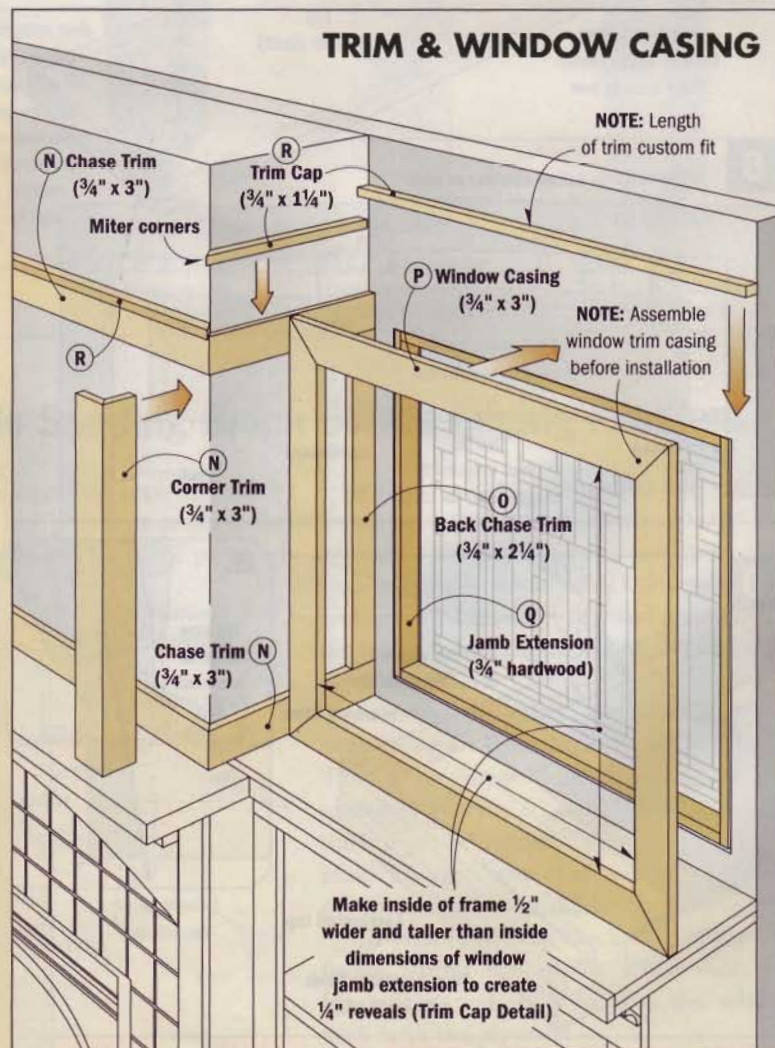
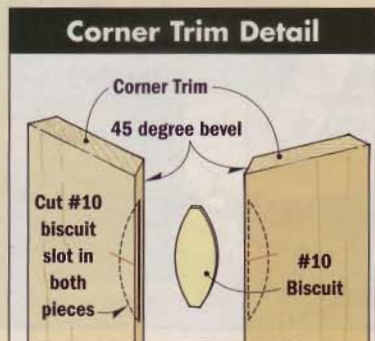
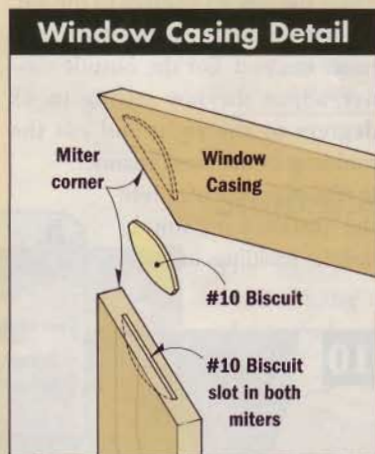
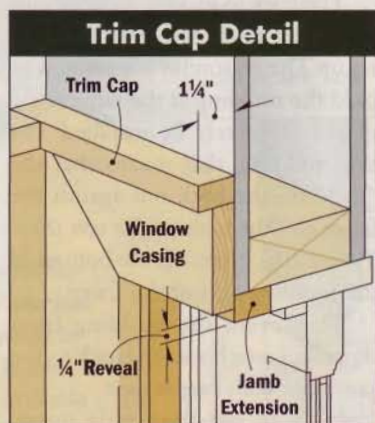

MATERIAL AND HARDWARE LIST

A (1) Bottom Rail (oak)	$\frac{3}{4}$ " x $7\frac{1}{4}$ " x 41"	K (1) Top (oak plywood laminated)	$1\frac{1}{2}$ " x $13\frac{1}{8}$ " x $43\frac{1}{4}$ "
B (1) Top Rail (oak)	$\frac{3}{4}$ " x 4" x 41"	L (1) Edging (oak)	$\frac{3}{4}$ " x $1\frac{1}{2}$ " x $44\frac{3}{4}$ "
C (2) Stiles (oak)	$\frac{3}{4}$ " x 3" x $43\frac{1}{4}$ "	M (2) Trim (oak)	$\frac{3}{4}$ " x $1\frac{1}{2}$ " x $13\frac{7}{8}$ "
D (2) Sides (oak plywood)	$\frac{3}{4}$ " x 11" x $54\frac{1}{2}$ "	N (2) Top Side Rail (oak)	$\frac{1}{2}$ " x 4" x $11\frac{1}{4}$ "
E (1) Bottom Shelf (oak plywood)	$\frac{3}{4}$ " x 11" x 39"	O (2) Bottom Side Rail (oak)	$\frac{1}{2}$ " x $7\frac{1}{4}$ " x $11\frac{1}{4}$ "
F (1) Shelf Support (oak plywood)	$\frac{3}{4}$ " x $6\frac{1}{2}$ " x $38\frac{1}{2}$ "	P (2) Front Side Stile (oak)	$\frac{1}{2}$ " x $2\frac{1}{4}$ " x $43\frac{1}{4}$ "
G (1) Back Rail (oak plywood)	$\frac{3}{4}$ " x $3\frac{1}{2}$ " x $38\frac{1}{2}$ "	Q (2) Rear Side Stile (oak)	$\frac{1}{2}$ " x 3" x $43\frac{1}{4}$ "
H (2) Mounting Cleat (oak)	$\frac{3}{4}$ " x $1\frac{1}{4}$ " x $10\frac{1}{4}$ "	R (1) Base Molding (oak)	$\frac{3}{4}$ " x 7" x $42\frac{1}{2}$ "
I (1) Back (oak)	$\frac{1}{4}$ " x 40" x 48"	S (2) Base molding (oak)	$\frac{3}{4}$ " x 7" x $12\frac{3}{4}$ "
J (2) Adjustable Shelf (oak)	$1\frac{1}{16}$ " x $10\frac{1}{2}$ " x $38\frac{3}{8}$ "		

CUTTING DIAGRAM

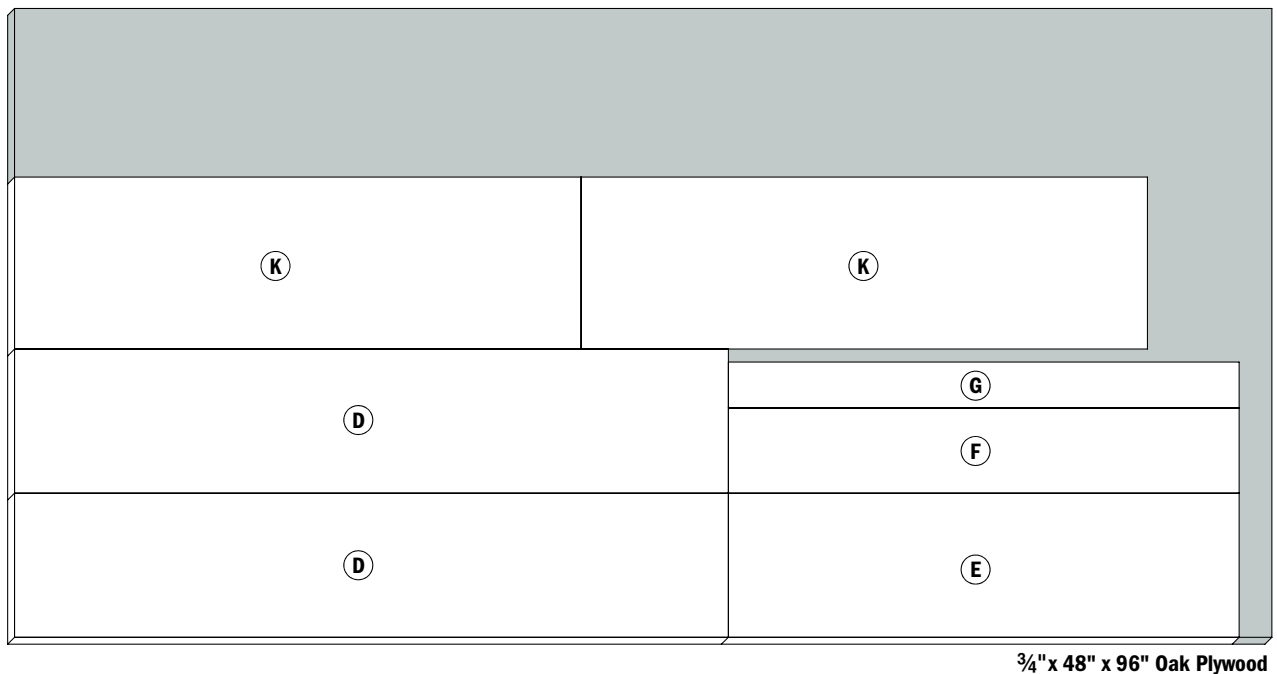
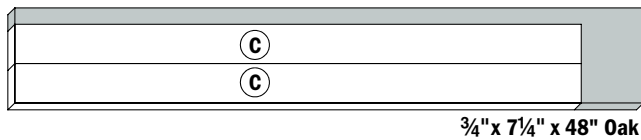
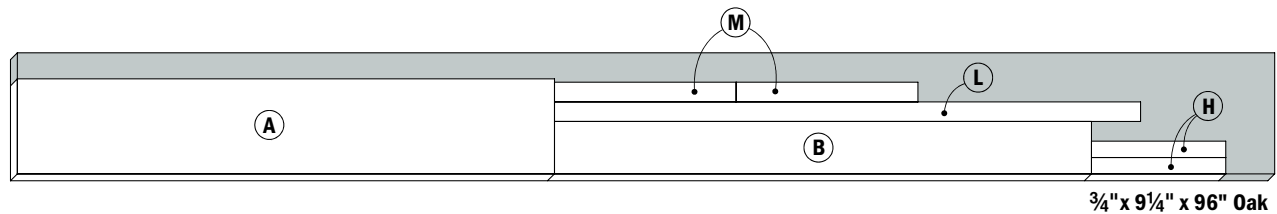

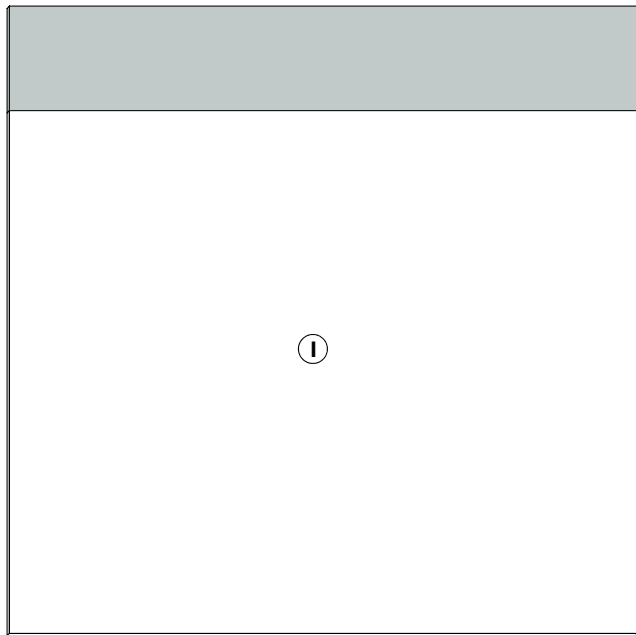

1/4" x 48" x 48" Oak Plywood



1/16" x 5 1/2" x 96" Oak

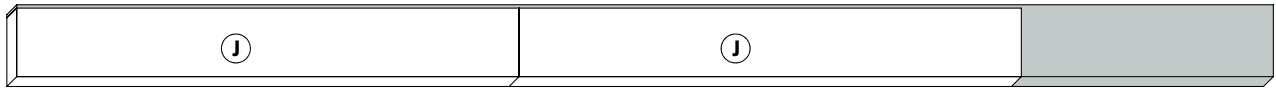

1/16" x 5 1/2" x 96" Oak



3/4" x 7 1/4" x 72" Oak

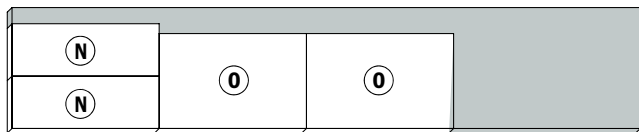

1/2" x 9 1/4" x 48" Oak

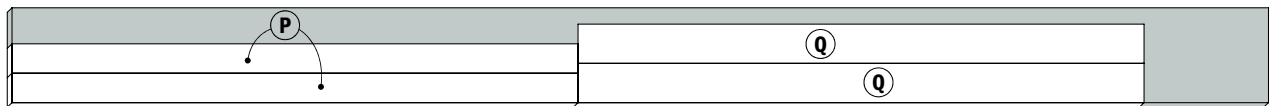

1/2" x 7 1/4" x 96" Oak

Classic Oak Bookcase

If this bookcase looks familiar, there's a good reason — it's essentially the same as the built-in bookcases featured in the "Fireside Retreat" on page 19. But in order to convert it into a freestanding unit, we've added a few distinctive details.

Since the sides of this bookcase are visible, *that's* where you'll notice the biggest differences. As you can see in the *Construction View* on page 29, I applied a solid-wood frame to each side. The trim strips are also different. Notice how the edging, cove molding, and base molding all wrap around the sides of the case.



CONSTRUCTION. The construction of the bookcase is very similar to the built-in unit. For starters, the face frame is identical. As before, it extends $\frac{1}{2}$ " past each side of the case. This way, it covers the front edges of the side frames, as shown in the *Corner Detail*.

The case itself is also identical. Here again, the face frame is attached to the case with biscuits. And two adjustable shelves made of solid wood complete the basic unit.

SIDE FRAMES. That brings us to the side frames which help to give this bookcase its distinctive look. These frames are simply applied to the sides of the bookcase, creating what appears to be a frame and panel assembly.

Unlike the face frame, the side frames are made of $\frac{1}{2}$ "-thick hardwood. Each side frame consists of a narrow top rail (N), a wide bottom rail (O), and two vertical stiles (P, Q), as shown in the *Side Frame*

Illustration below. The side frames are assembled with biscuit joints and glued to the case.

TOP. Another thing that's different about this freestanding bookcase is the size of the top. To accommodate the cove molding on the sides, the top is a little longer than the built-in unit. As for width, I made it a bit narrower. (The built-in bookcase has a wider top, which makes it look more in proportion with the fireplace mantel.)



**Classic Oak
Bookcase
Cutting
Diagram**

WorkbenchMagazine.com

CONSTRUCTION VIEW

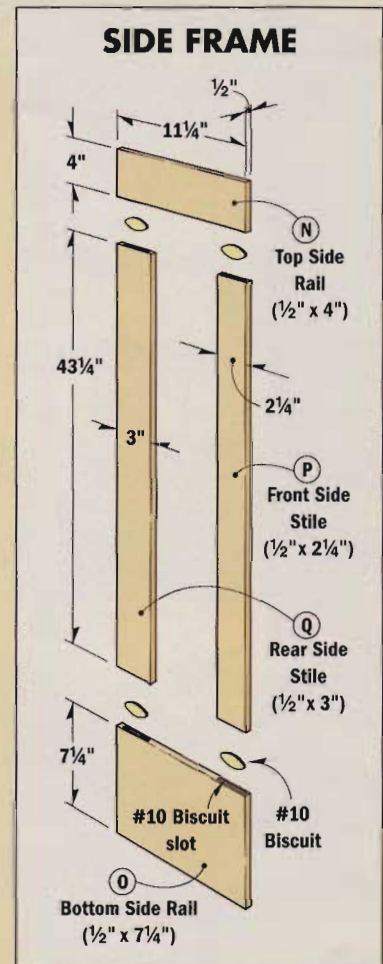
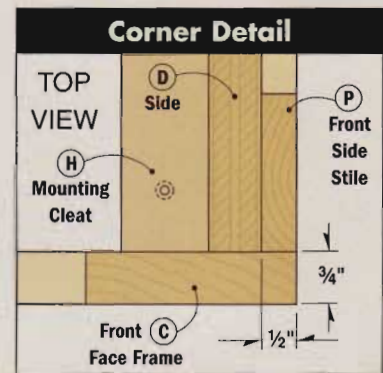
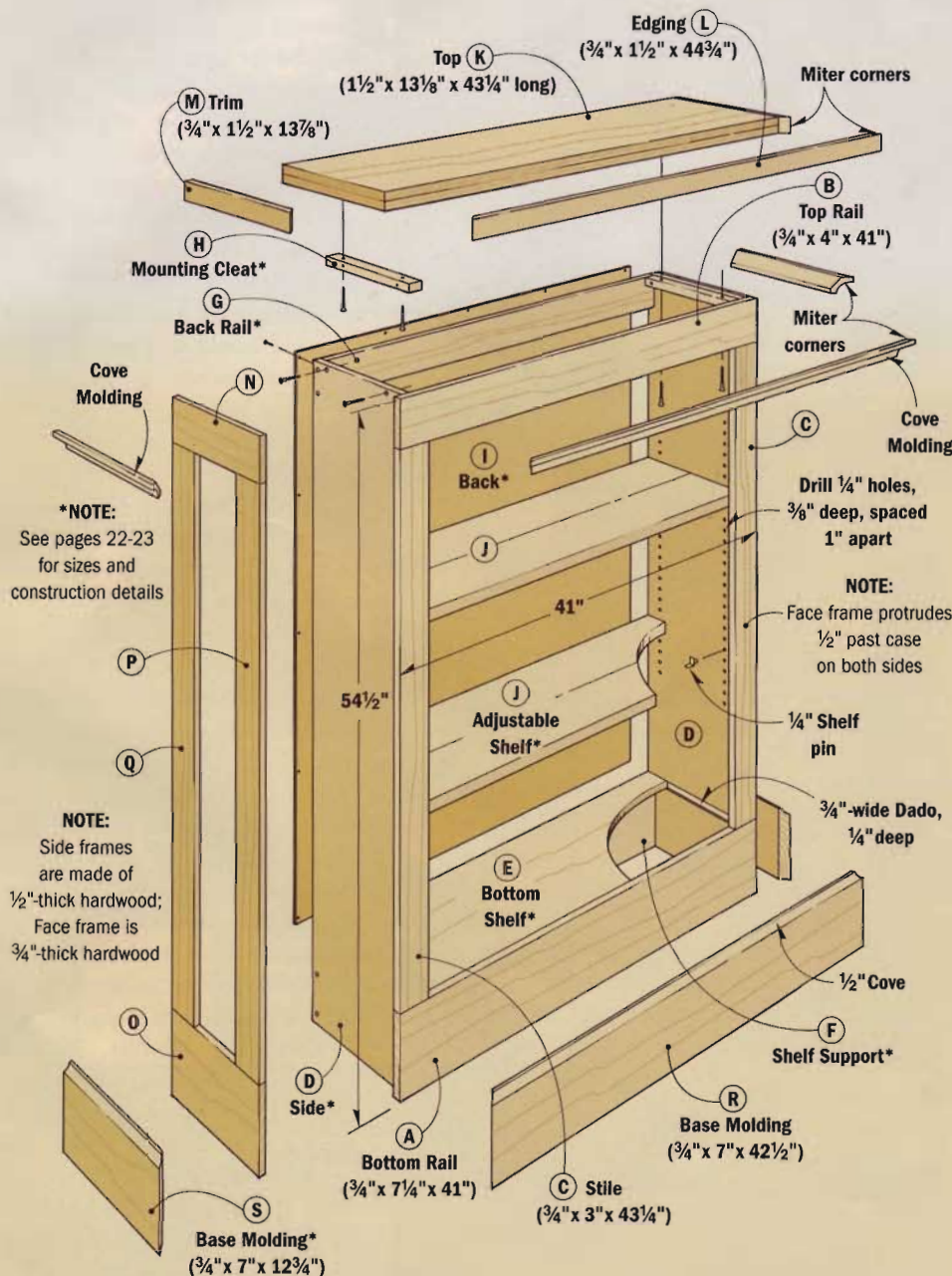

Shaker-Style Pedestal Table

Don't be fooled by the elegant details of this table. It's easier to build than you think — thanks to a unique routing technique.



When it came to design, the Shakers had it all figured out. They built pieces of furniture that were both practical *and* beautiful.

This pedestal table is a good example. The curved, umbrella-like legs and the turned, tapered spindle provide stable support for the tabletop. And the long, narrow drawers, which open from either end, simply hang below the top.

To highlight the curved, graceful lines of the table, I built it from highly-figured curly maple (see sidebar on page 31). Of course, the table would also look great in cherry, walnut, or even with a painted finish.

But don't build this table just because it looks nice. It also provides a great opportunity to try out some intriguing woodworking techniques, starting with the spindle of the pedestal base.

TURNUED SPINDLE. Now you'd expect that this spindle is turned to shape on a lathe. And that's a good way to do it, *if* you have a lathe.

If not, don't worry. You can "turn" the spindle to shape on a router table instead. It's an interesting technique that's easy to master. And, as you can see from the spindle on this table, it produces great results. (For more information on this technique, turn to page 40.)

ANTIQUÉ FINISH. Another technique that's definitely worth a closer look is how the finish is applied to the table. I used a special finish that creates a deep, rich color and highlights the figure of the curly maple. (You can learn more about this on page 44.)

PEDESTAL TABLE CONSTRUCTION VIEW

Overall Dimensions: 22" W x 22" D x 28" T

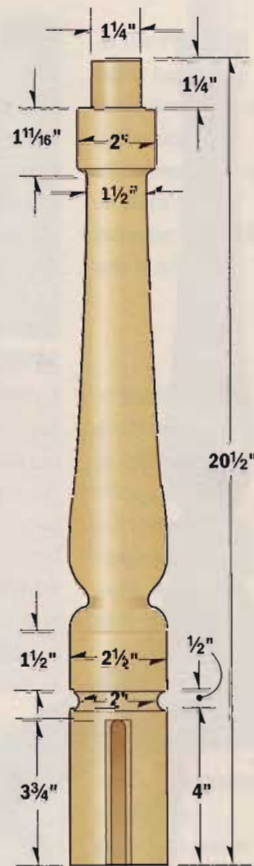
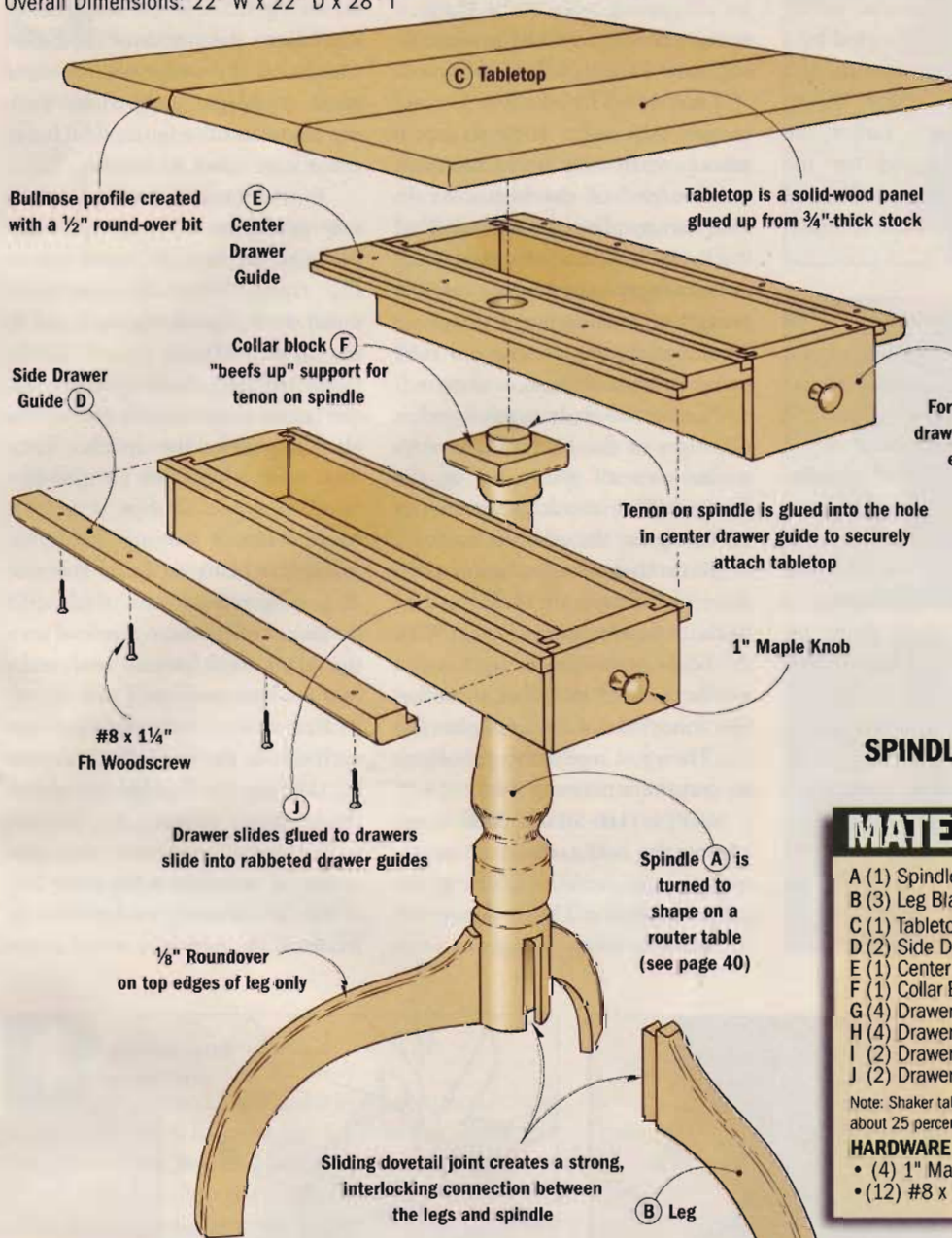

SPINDLE DETAIL

MATERIALS LIST

A (1) Spindle (maple)	2 1/2"-dia. x 20 1/2"
B (3) Leg Blanks (maple)	3/4" x 5 1/2" x 15"
C (1) Tabletop (maple)	3/4" x 22" x 22"
D (2) Side Drawer Guides (maple)	3/4" x 1 1/2" x 20 1/2"
E (1) Center Drawer Guide (maple)	3/4" x 3" x 20 1/2"
F (1) Collar Block (maple)	1 1/2" x 3" x 3"
G (4) Drawer Fronts/Backs (maple)	3/4" x 4" x 6"
H (4) Drawer Sides (maple)	1/2" x 4" x 20"
I (2) Drawer Bottoms (birch plywood)	1/4" x 5 1/2" x 19 1/2"
J (2) Drawer Slides (maple)	3/8" x 3/8" x 20 1/2"

Note: Shaker table requires about 18 bd. ft. of lumber. This allows for about 25 percent extra, and it includes the 3" x 3" turning blank.

HARDWARE

- (4) 1" Maple Knobs
- (12) #8 x 1 1/4" Fh Woodscrews

CURLY MAPLE MAGIC

It's not just the Shaker styling of this pedestal table that attracts attention. The curly maple we used to build it also contributes to its dramatic appearance. Once a finish is applied, the ribbon-like figure of the maple appears to shimmer and take on a three-dimensional look.

The term "curly" maple describes the figure of the wood — not the type of maple. It occurs most often in soft maple. But don't expect to sort through a stack of soft maple and find the curly stuff.

That's because the figured wood is a real prize for many woodworkers. So it's usually sorted and sold separately.

SOURCES. You can find curly maple at some lumberyards. Or, you can order it by mail. Expect to pay about \$9 to \$12 a board foot. It's available from:

- Sandy Pond: 800-546-9663
www.figuredhardwoods.com
- Steve Wall Lumber Co.: 800-633-4062
www.walllumber.com

- Spectrum Hardwoods: 541-382-2400
www.wood@spectrumhardwoods.com
- MapleLeaf Hardwoods: 570-584-5072
www.curlymaple.com



▲ This graceful pedestal provides support for the tabletop, a perfect blend of form and function.

START WITH THE PEDESTAL

In keeping with traditional Shaker design, this table is supported by a graceful pedestal that consists of a turned spindle and three curved legs. As I mentioned earlier, the spindle will be shaped on the router table. But first, you'll need to prepare a blank for the spindle.

SPINDLE BLANK

I started with a 3" x 3" chunk of solid wood (curly maple). But you could also glue up a wood blank. As for length, I cut the blank 28" long. That left it about 7½" longer than the finished spindle, which allowed for plenty of waste at each end.

HEXAGONAL BLOCK. The next step is to make the blank into a hexagonal block. There are a couple of reasons for this. First, the flat sides of the blank make it easy to rout the dovetail-shaped leg sockets, as you can see in the photo on page 33.

Second, by cutting one socket on alternating sides of the blank, it ensures the legs will be symmetrical around the spindle (120° apart).

LAYOUT. The best way I found to get a hexagon with six equal sides is to first lay out a rectangle on one end of the blank. To do that, start by planing the blank 2⅝" thick. Next, draw diagonal lines from corner to corner to locate the center of the rectangle (Fig. 1). Then use a compass set for a 1¼" radius to draw a circle, as shown.

Notice the circle nearly touches two sides of the blank. These sides define two of the sides of the hexagon. They also act as a reference for laying out the other four sides.

To do that, set a protractor at 60 degrees and position it against one of the reference sides (Fig. 2). With the blade of the protractor tangent to the circle, draw a line to define one more side of the hexagon (Fig. 2a). Then just repeat this process to lay out the remaining sides.

BEVEL THE SIDES. After completing the layout, the next step is to bevel rip the sides of the blank on the table saw. This is done with the blade tilted to 60 degrees.

One thing to keep in mind is to set the rip fence so the waste material falls to the *outside* of the blade. Otherwise, the wedge-shaped waste piece could get pinched between the blade and the fence, which can cause it to shoot backwards.

To prevent that, consider which way the blade on your table saw tilts. On my saw, the blade tilts to the right (from the operator's view). So I moved the rip fence to the *left* of the blade.

Once that's accomplished, use the layout lines on one end of the blank to position the rip fence. Then lock it in place and rip the first bevel, as shown in Figs. 3 and 3a. Next, without moving the fence, rotate the blank to bevel the side diagonally across from the first side.

To complete the operation, turn the blank end-for-end and make two final passes (Figs. 4 and 4a).

Before you continue, measure each side of the blank (from corner to corner). To ensure consistent results when routing the dovetail sockets, it's important that the width of each side is the same.

So if necessary, nudge the rip fence on the table saw a hair closer

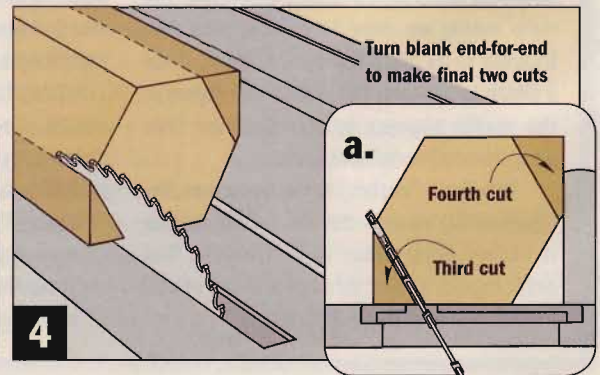
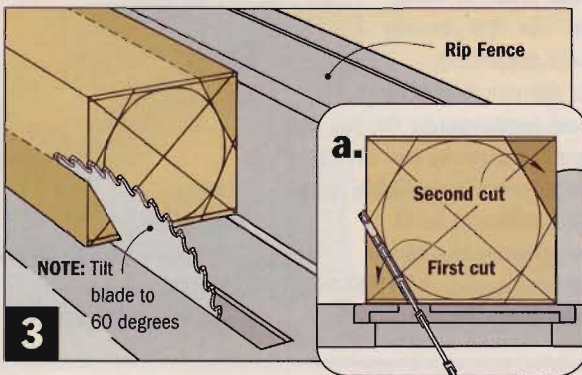
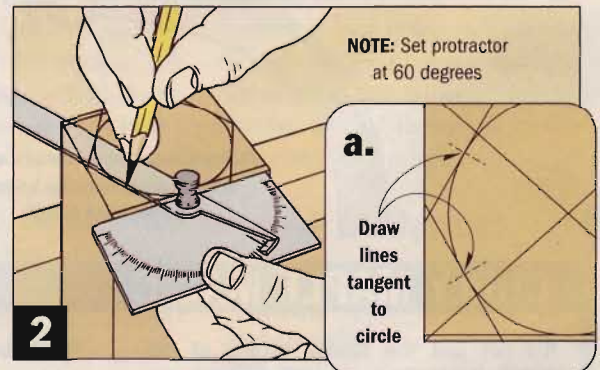
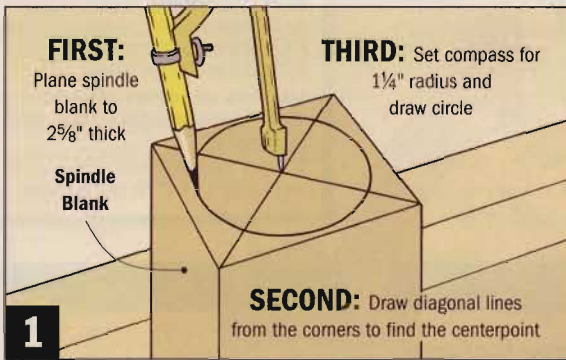

to the blade and rip the sides of the blank again. Continue like this until all six sides are identical in width.

DRILL & TAP HOLES. There's one final thing to do. That's to drill and tap a centered hole in each end of the blank. These holes accept bolts that will be used to mount the blank in the turning jig. (For more on drilling and tapping these holes, see page 56.)

ROUT THE DOVETAIL SOCKETS

At this point, it's time to head for the router table to cut the three dovetail-shaped sockets that hold the legs in the spindle.

TWO GROOVES. If you look at the photo at right, you can see each socket actually consists of *two* grooves. There's a wide, shallow groove in the outer face of the side. And a deep, dovetail-shaped groove completes the socket.

So what's the point of having *two* grooves? It has to do with how the tenons on the legs fit in the sockets. The shallow grooves will allow the shoulders of the tenons to be "buried" in the spindle (see Photo on page 34). This means you'll be able to leave the shoulders square, instead of having to shape them to match the curve of the spindle.

There's nothing complicated about routing the dovetail sockets. To make each socket, you'll need to use three different router bits: a $\frac{3}{4}$ " straight bit, a $\frac{3}{8}$ " straight bit, and a $\frac{3}{4}$ " dovetail bit.

SETUP. To set up the router table, start by mounting the $\frac{3}{4}$ " straight bit and then adjusting it for an $\frac{1}{8}$ " depth of cut. Then position the router fence so the bit is centered on the sides of the blank.

The best way I found to do this was to "eyeball" the location of the fence, make a *short* test cut, and then adjust the fence as needed. Don't worry about cutting into the blank. Remember, there's nearly 4" of waste on each end, so any test cuts will be removed with the waste.

The final setup step is to mark a reference line on the router table fence that shows where to stop the

cut. To do this, start by making a mark that aligns with the leading edge of the bit (Fig. 5a). Then measure $7\frac{1}{2}$ " ($3\frac{3}{4}$ " for the length of the socket and $3\frac{3}{4}$ " of waste) from there and mark the stop line (Fig. 5).

ROUT GROOVES. With the setup complete, rout the $\frac{3}{4}$ "-wide groove in three of the sides (Fig. 6a). Just be sure to leave one side uncut between each groove.

From this point forward, you won't need to adjust the fence. All you have to do is change the bit.

With that in mind, mount a $\frac{3}{8}$ " straight bit to remove the bulk of the waste. Then make two successively deeper passes (Fig. 6b).

Now it's just a matter of routing the dovetail groove. After mounting a $\frac{3}{4}$ " dovetail bit in the router and adjusting it for a $\frac{5}{8}$ "-deep cut, a single pass is all that's needed to complete each socket (Fig. 6c.)

Finally, use a chisel to square up the end of the shallow groove.



▲ The sockets that hold the legs are formed by routing a wide, shallow groove and a deep, dovetail-shaped groove.

TEMPLATE PATTERN

TURN TO TURNING

With the sockets completed, the next step is to shape the spindle. I used the router technique shown on page 40 to "turn" the spindle to shape. To get started, you'll need to make a hardboard template of the spindle. Enlarge the pattern shown at right to make the template.

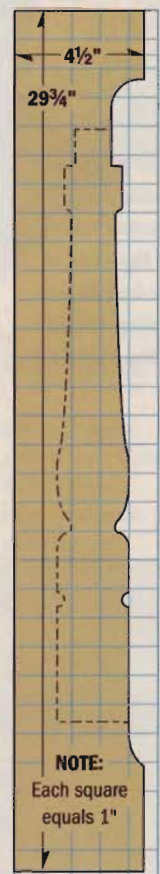

NOTE: Enlarge pattern twice at 200 percent, once at 166 percent

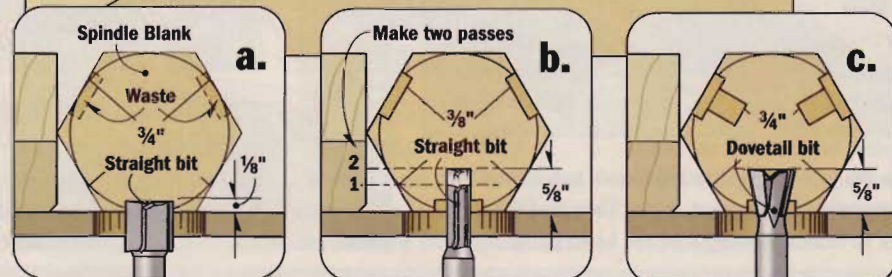
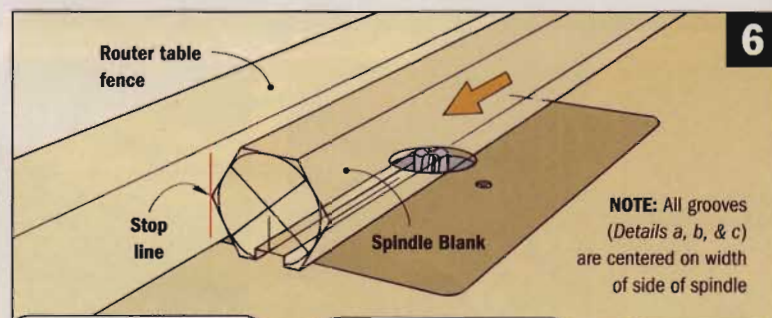
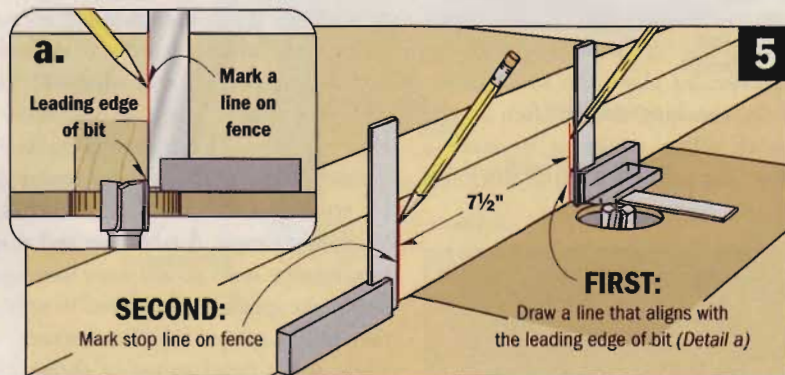



▲ To produce a stable pedestal, dovetail tenons on the ends of the legs fit into mating sockets in the spindle.

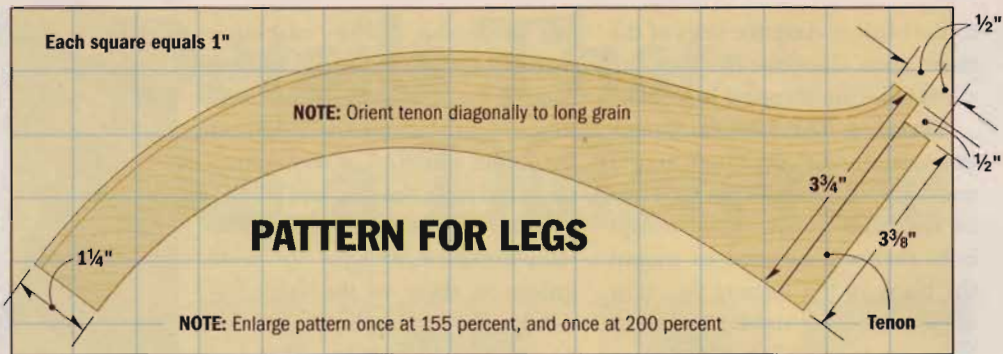

ADD THE LEGS

With the spindle turned to shape, sanded smooth, and cut to length, you're ready to add the legs (B). As you can see in the photo above, a dovetail-shaped tenon on the end of each leg fits into a socket in the spindle. This forms a strong, interlocking joint, which produces a sturdy base.

LEG BLANKS. The first step is to cut three blanks to rough size ($5\frac{1}{2}'' \times 15''$). To create a tight fit, the thickness of these blanks must match the $\frac{3}{4}''$ -wide groove in the spindle. So plane the blanks carefully, checking the fit often as you work. While you're at it, make a few test pieces the same thickness

as the leg blanks. They'll come in handy when setting up the router table to cut the dovetail tenons.

ATTACH PATTERN. The next step is to make a pattern of the shape of the leg and then attach one to each blank (see *Pattern* above). When positioning the pattern, there are two things to consider.

First, to make the legs as strong as possible, orient the pattern so the dovetail tenon is at an angle to the *long grain* of the blank. Also, for the best appearance, try to set the pattern across the most highly-figured grain. Then attach a pattern to each blank with spray-mount adhesive.

Now you're ready to cut the legs to shape. The first step is to define the end of the dovetail tenon by trimming the corner of each blank at an angle. A table saw and a miter gauge with an auxiliary fence will make quick work of this. To set the miter gauge to the correct angle, use a bevel gauge, as shown at left. Then simply trim the corner (Fig. 7). Note: You'll need to readjust the angle of the miter gauge for each blank.

The next step is to cut the legs to rough shape using a band saw (Fig. 8). Be sure to stay to the waste side of the layout lines. Then sand up to the line using a drum sander chucked in the drill press.

Finally, to ease the sharp edges, I routed a small ($\frac{1}{8}''$) roundover on the top edges of each leg.

ROUT THE DOVETAIL TENONS

At this point, you can concentrate on routing the dovetail tenons to fit the sockets. This is accomplished on the router table — with the same $\frac{3}{4}''$ dovetail bit used to cut the dovetail grooves in the spindle.

AUXILIARY TOP. When routing the tenon, the idea is to stand the leg on end as you slide it across the router bit. I didn't want the leg to tip into the opening in the table insert. So I "closed" the opening by adding an auxiliary top to the table (Fig. 9). This is just a piece of $\frac{1}{4}''$ hardboard with a 1" hole drilled in it to provide clearance for the bit.

SETUP. After clamping the top in place, you can go ahead and set up the router table. There are two

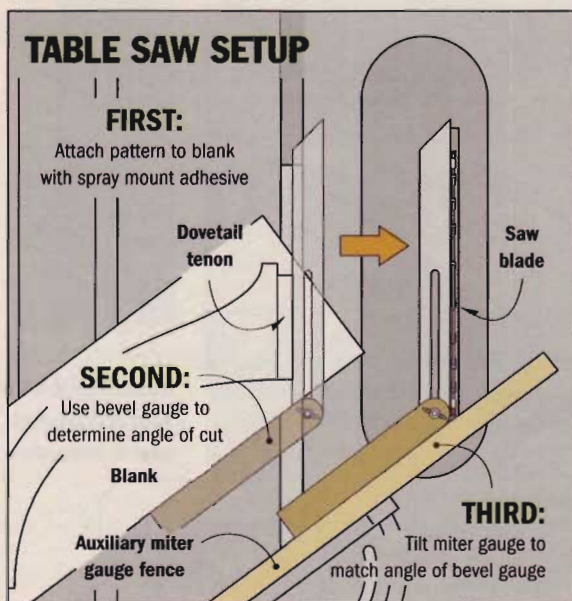

▲ To define the end of the dovetail tenon, use a bevel gauge to determine the correct angle. Then just tilt the miter gauge to match the angle of the bevel gauge.

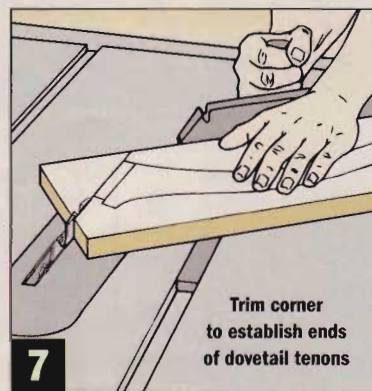

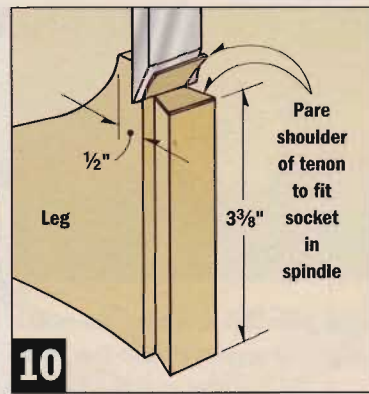
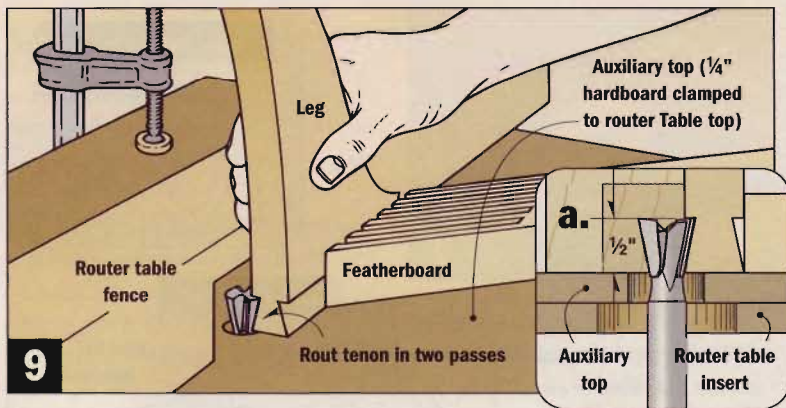

things to consider here: the height of the router bit and the distance of the fence from the bit. Getting both things adjusted just right is a trial-and-error process, which is where the test pieces you made earlier will come in handy.

BIT HEIGHT. Start by adjusting the height of the bit. A look at the photo on page 34 shows what you're aiming for. The tenon on the leg should "bottom out" in the socket, and the shoulders of the tenon should fit snugly against the lip formed by the shallow groove.

To accomplish that, adjust the height of the bit to $\frac{1}{2}$ " as a starting point. Keep in mind that you may have to "tweak" the adjustment before cutting the tenons.

FENCE SETUP. But first, you'll have to set up the fence on the router table. As you can see in *Figures 9 and 9a*, only a small part of the cutting edge is exposed when routing the tenon. So start by adjusting the fence so the bit will just graze the side of the leg. Then rout a test piece, making a single pass on each side. The tenon probably won't fit in the socket yet. But give it a try anyway to see how much you need to adjust the fence.

Keep in mind that even a small fence adjustment will make a big difference in how the joint will fit together. That's because you'll be making a pass on each side, in effect, removing twice the amount of material. So move the fence away from the bit just a hair, make two more passes with the test piece, and check the fit again.

The goal here is a fairly tight-fitting joint. If it's too loose, the leg will wobble in the socket. The trouble is it's all too easy to go from a joint that's too tight to one that's too loose — even with the slightest movement of the fence.

To avoid that, try making two passes *without* moving the fence at all. Simply press the leg more firmly against the fence. Sometimes this will shave off just the right amount of material to get a perfect fit.

Once you're satisfied with how the tenon on the test piece fits into the socket, you can rout the tenons on the legs. A single pass on each side of the leg is all it takes. Then, to fit the tenon into the socket, pare a small amount of material off the upper corner of the leg, as shown in *Figure 10*.

As you fit the joints, it's a good idea to keep track of which legs fit into which sockets. There shouldn't be much difference between them anyway. But labeling the legs just in case will help you avoid any unpleasant surprises during glue-up.

ASSEMBLE LEGS & SPINDLE

The sliding dovetail joints provide a great deal of mechanical strength. In fact, a tight-fitting joint will hold the legs and spindle together — without using glue at all. Even so, the tenons could shrink and cause the legs to loosen up. So it's a good idea to apply glue *sparingly* as you assemble the pedestal.

My concern was that if I saturated a socket with glue and then slid the leg into place, the water in the glue would cause the wood to swell. As a result, the tenon could seize up before it was seated all the way in the end of the socket.

The solution is to apply glue in two places: at the *stopped* end of the socket and also on the *trailing* end of the tenon (*Figs. 11 and 11a*). This makes it easy to fully seat the tenon in the socket. And it provides plenty of gluing surface to hold the legs.

As far as clamping the legs, there's no need to apply any additional pressure. The joint should be tight enough to hold the pieces together while the glue dries.

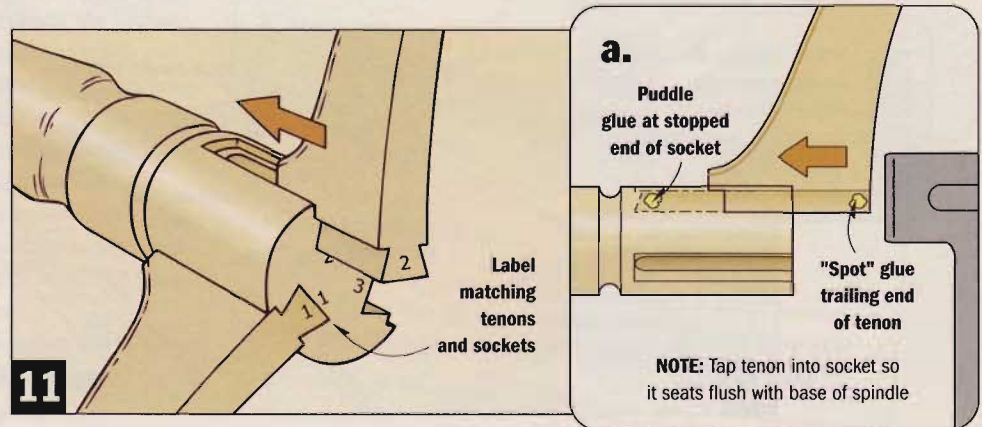

TABLETOP ASSEMBLY

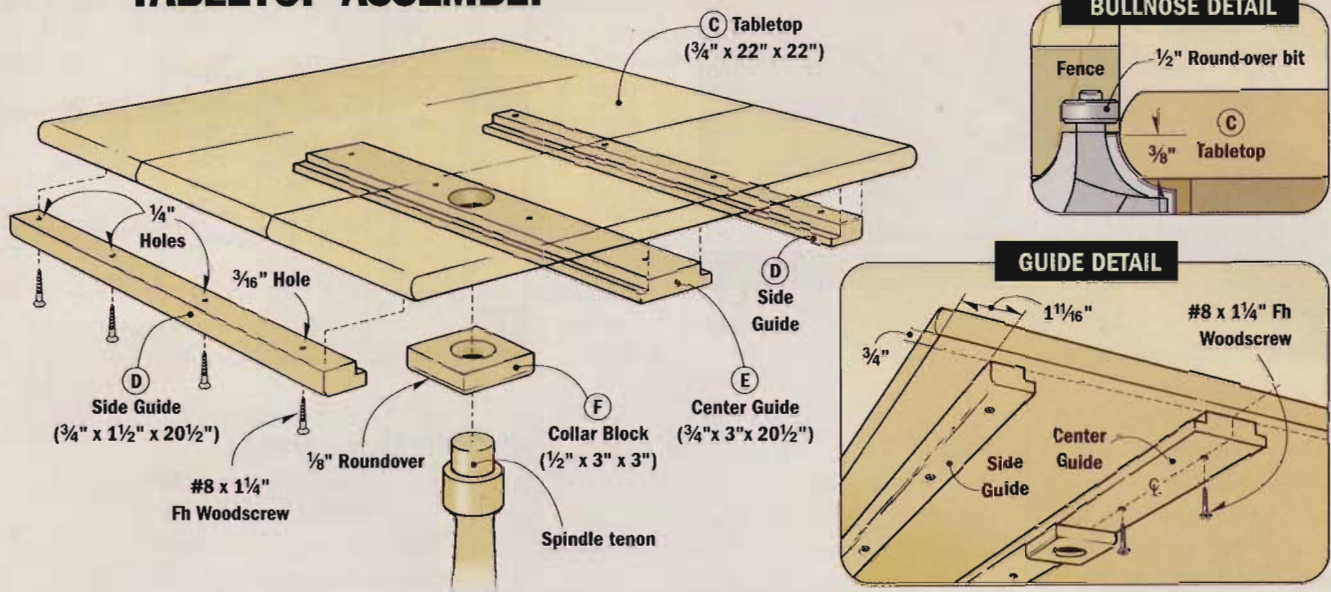

TIME FOR THE TABLETOP

The tabletop (C) is a solid-wood panel that's made by edge-gluing three boards together (*Tabletop Assembly*). To make the joint lines as inconspicuous as possible, I selected boards for their color and figure, arranging them so the grain "flowed" from one board to the next.

SIZE. The finished size of the top is 22" x 22", but it's best to start with an oversize panel (about 1" wider and 4" longer than needed) and then trim it to final size later.

Start by jointing and planing enough stock to make the panel. I planed the boards $\frac{13}{16}$ " thick. This way, I was able to glue up the panel, sand it flat, and still end up with a top that was a "strong" $\frac{3}{4}$ " thick. (See page 59 for tips on using a belt sander to flatten a panel.)

TRIM TO SIZE. After sanding the panel flat, the next step is to trim it to size. Cutting it to width is easy. Just set the rip fence on the table saw and run the straight edge against the fence. But crosscutting the panel to length presents a problem — it doesn't have a straight edge to ride against the rip fence.

So in order to create a straight edge, I attached a framing square to the panel with carpet tape so it extended over the edge (*Figs. 12 and 12a*). This way, the square rides against the fence as you trim the end. To cut the opposite end, just remove the square and run the cut edge against the fence.

DECORATIVE PROFILE. All that's left to complete the tabletop is to rout a decorative profile around all four edges. I used a $\frac{1}{2}$ "

round-over bit to rout a partial ($\frac{3}{8}$ ") roundover on the top and bottom, creating a bullnose profile, see *Bullnose Detail* above.

A SIMPLE GUIDE SYSTEM

The next step is to add three hardwood strips that suspend the drawers underneath the table and guide them in and out.

If you look at the *Tabletop Assembly*, you'll see that there are two narrow side guides (D) and a wider center guide (E). In addition, a small collar block (F) houses the top of the spindle, creating a secure attachment.

The guides are strips of $\frac{3}{4}$ "-thick maple that are cut to length so the top overhangs by $\frac{3}{4}$ " (*Guide Detail*). You can rip the center guide (E) to final width. But to safely machine the side guides, it's best to start with an extra-wide blank (*Fig. 13*).

CUT RABBETS. The first step in this process is to cut a rabbet in the two long edges of the center guide and the blank for the side guides (*Figs. 13 and 13a*). Later, these rabbets will form a track that will be used to guide the drawers in and out of the table.

RIP, THEN ROUT. At this point, you can rip the blank for the side guide into two pieces. Then, in

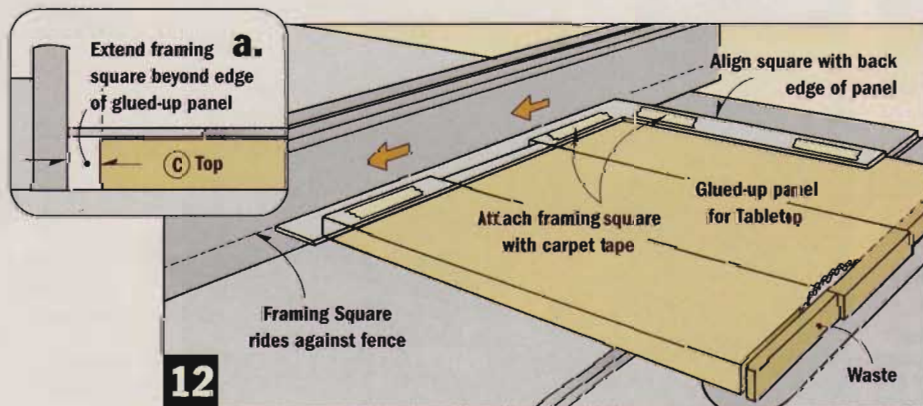

order to soften the lower outside edge of each side guide, I routed a small roundover (Figs. 14 and 14a).

Before attaching the guides to the table top, there's one more thing to do. To create a sturdy connection between the pedestal and the tabletop, the center guide has to be "beefed up" a bit.

COLLAR BLOCK. That's the job of the collar block (F). This is a 3"-square block made of 1/2"-thick hardwood that's attached to the center guide. Again, to soften the appearance of the collar block, rout an 1/8" roundover on the bottom edges. Then simply center it on the length of the center guide, flush with the edges, and glue it in place.

Next, to accept the tenon on the spindle, you'll need to cut a round mortise. To do this, I drilled a 1 1/4" centered hole in the glued-up assembly with a Forstner bit (Fig. 15). Just be sure the bit is square to the drill press table. If it isn't, the top will sit crooked.

ATTACH GUIDES. Now you're ready to attach the guides to the tabletop. To prevent the drawers from binding, it's important that all three guides are parallel to each other. Also, be sure the guides are set back 3/4" (to allow for the table overhang) and aligned at the ends (see *Guide Detail* on page 36).

The guides are held in place with screws. But since the top is solid wood, it will expand and contract with changes in humidity. To allow for that, I drilled oversize (1/4") shank holes for all the screws except for those closest to the front

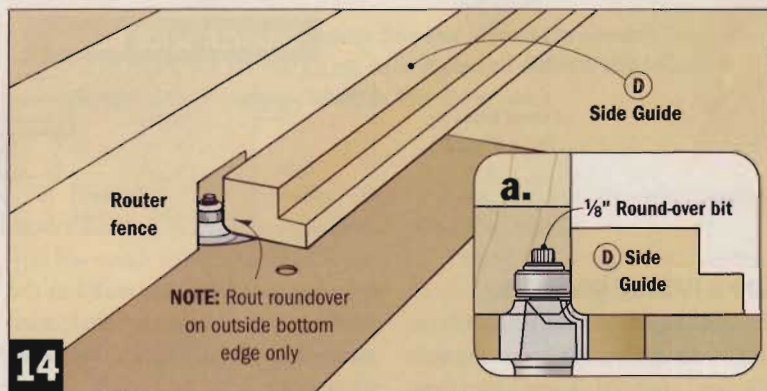
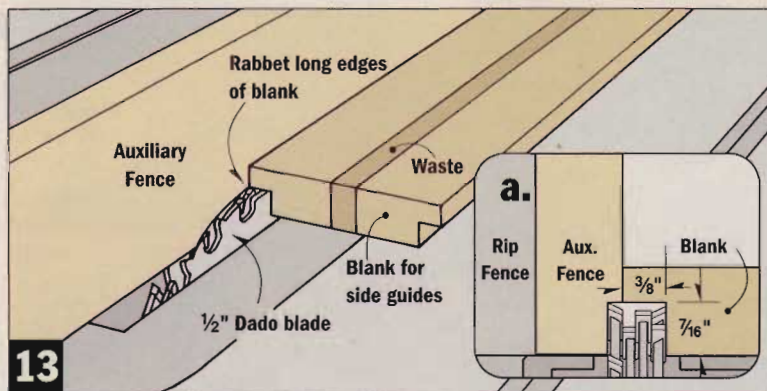

edge of the top. These front screws pass through smaller (3/16") holes. This secures the front portion of the top, but allows the rest to "float."

GLUE PEDESTAL TO TOP

All that's left for this part of the project is to glue the tabletop onto the pedestal. There's nothing complicated about this. In fact, the hardest part is deciding how to orient the top in relation to the legs.

In the end, I decided to center one of the legs between the two drawers. An easy way to get this leg to stay put is to prop the other two legs while the glue dries (Fig. 16).

To avoid a messy glue-up, but still provide a strong connection, brush glue around the top of the tenon and the lower part of the mortise. Then simply slide the tenon into the mortise and prop the pedestal as shown.

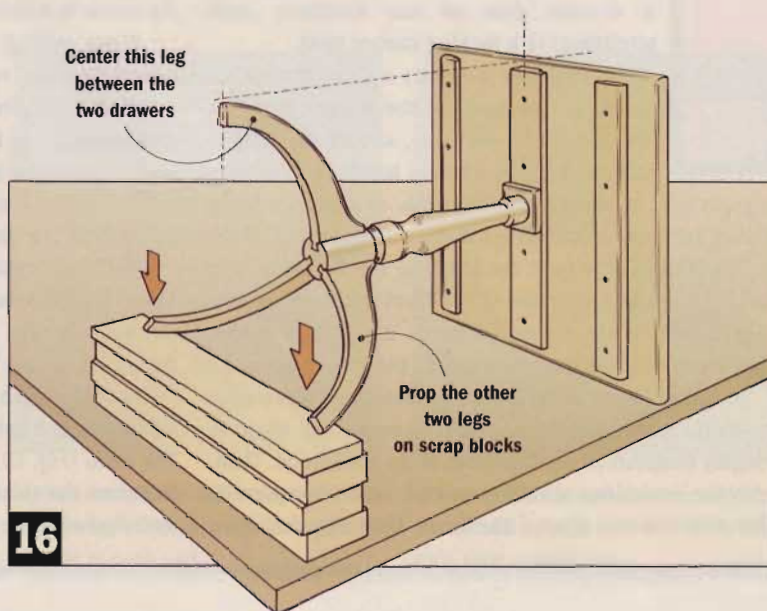
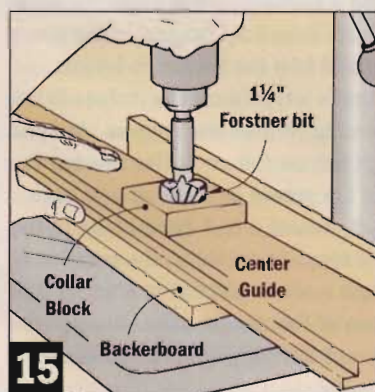

DRAWER ASSEMBLY

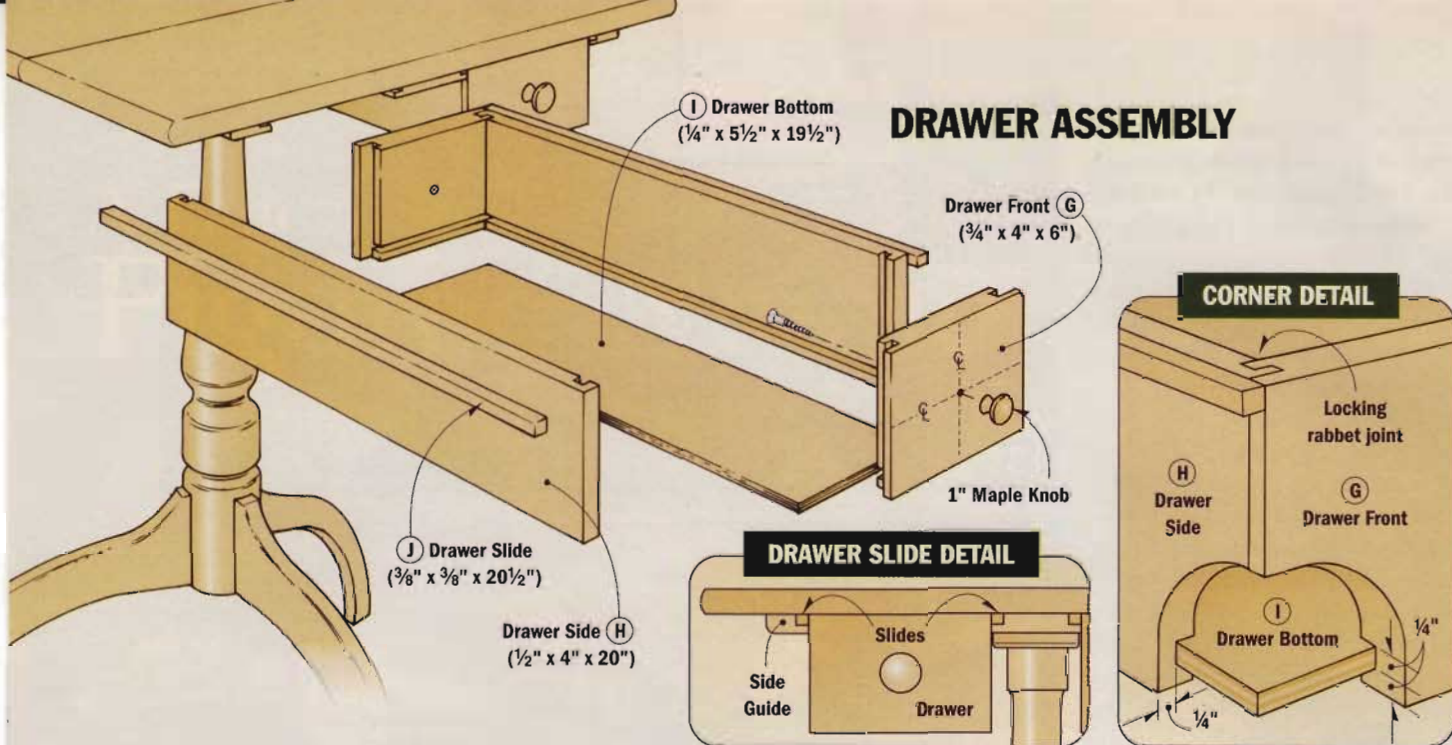

ADD A PAIR OF DRAWERS

The final part of this project is to add two long, narrow drawers (*Drawer Assembly*). They hang from the guides by narrow strips of wood attached to the sides of the drawers. This provides a simple, effective guide system for the drawers.

One interesting note about the drawers is shown in the photo on page 39. In keeping with the table's traditional design, the drawers can

be opened from either end. For the Shakers, this meant that two women could work at the table, each with easy access to sewing supplies. But even in a contemporary setting, this double-ended drawer should come in handy.

JOINERY. As for the joinery used to assemble the drawers, the Shakers would have used dovetail joints. To simplify the construction, I used locking rabbet joints instead

(*Corner Detail*). This type of joint provides a strong, interlocking connection that won't come apart.

CONSTRUCTION. To match the rest of the table, I used curly maple for all of the drawer parts except the bottom: $\frac{3}{4}$ "-thick stock for the front and back pieces and $\frac{1}{2}$ "-thick material for the sides.

After planing the drawer stock to thickness, the next step is to cut the front, back (G) and sides (H) to

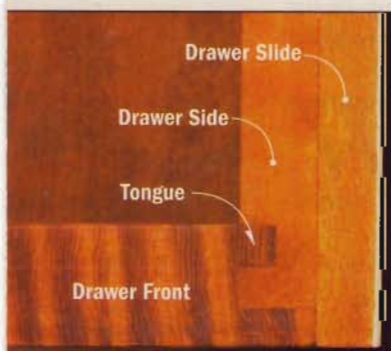

LOCKING RABBET JOINTS MADE EASY

There are probably a dozen different joints that can be used to join the four corners of a drawer. One of the simplest (and strongest) is a locking rabbet joint.

This type of joint has a short tongue on the front and back of the drawer that fits into a dado in the side, see *Photo* at left. This "locks" the corners together, providing

a great deal of mechanical strength, as well as a large gluing surface, which makes it even stronger.

THE TONGUES. To form the tongues, the first step is to cut a groove in both ends of the front and back pieces (*Fig. A*). For these drawers, I made a $\frac{1}{4}$ "-wide groove that's centered on the thickness of the front and back.

To make it easy to center the groove, I use a two-pass method. Start by adjusting the fence so the blade is roughly centered on the thickness of the workpiece. Then, with the workpiece standing on end, make two passes, first with one side against the fence, then with the other.

The next step is to trim the tongue to length (*Fig. B*). I wanted to end up with a $\frac{1}{4}$ "-long tongue. So I set the rip fence to establish the final length of the tongue.

When cutting the tongue, there's one thing to be aware of. If you remove the waste in a single pass, the cutoff can get pinched between the blade and the fence and come flying back. To prevent that, trim the end of the tongue first, using a backerboard to push the workpiece through the blade. Then butt the end of the piece up against the fence and trim the tongue to length.

DADOES. Now all that's left is to cut the dadoes in the sides. The dadoes need to fit over the tongues. And the narrow stub (the part left on the end after you cut the dado) has to slip into the groove in the front and back.

To accomplish that, mount a $\frac{1}{4}$ " dado blade in the table saw and set the fence to establish the location of the dado (*Fig. C*). Then make a test cut in a scrap that matches the thickness of the drawer sides. Once you're satisfied with the fit, cut the dadoes in the sides.

size (*Drawer Assembly*). Note: The dimensions shown take the joinery into account, as well as a $\frac{1}{16}$ " gap on both sides of each drawer.

With the pieces cut to size, you can turn your attention to cutting the locking rabbet joints, as explained in the sidebar on page 38.

DRAWER BOTTOM. With the joinery completed, it's time to add the drawer bottom (I). This is a piece of $\frac{1}{4}$ " birch plywood that fits into a groove in the drawer front, back, and sides (*Corner Detail*).

One thing to note is that $\frac{1}{4}$ " plywood isn't actually $\frac{1}{4}$ " thick — it's thinner. So to get a good fit, I used a two-pass method on the table saw. To do this, start by setting the rip fence $\frac{1}{4}$ " from the inside of the blade (Figs. 17 and 17a). Then make a single pass in each drawer piece. While you're at it, make this same cut in a test piece — you'll need it to set up for the second pass.

To make this pass, nudge the fence away from the blade, make a test cut, and check the fit. Now complete the grooves by making a second pass in each drawer piece.

ASSEMBLY. Before gluing up the drawers, drill a hole in the front and back for a wood knob. (It's

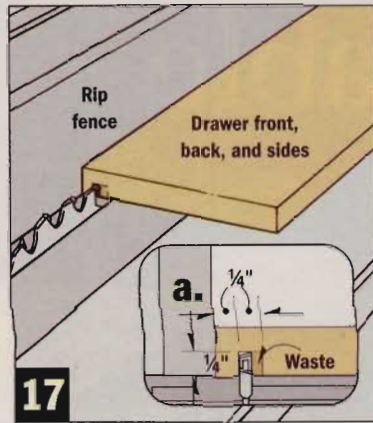

17

easier to do this now than after assembling the drawer.) Then just glue and clamp the drawers together.

DRAWER SLIDES. The next step is to add the drawer slides (J). These are long, narrow strips of hardwood that are glued flush with the top edges of the drawer sides (Fig. 18). This forms a lip on each side that fits into the drawer guides.

FINISH LINE. Finally, to complete the table, I gave it a light sanding and applied a finish. Actually, since this table is such a special project, I thought it deserved a special finish — one that befits its Shaker heritage. To learn more about this finish, please turn to page 44.

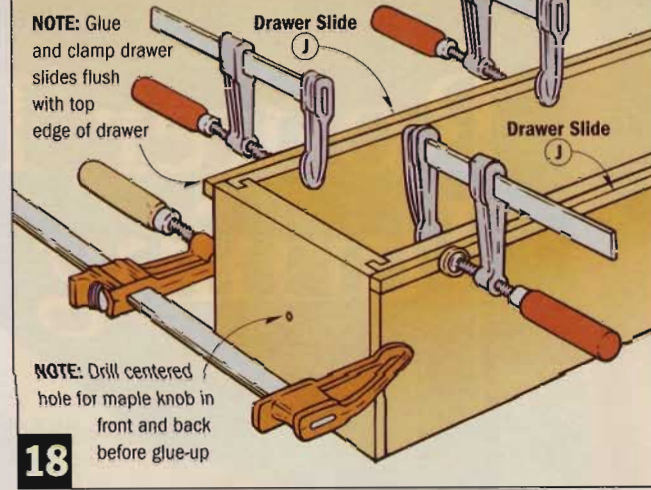

18



▲ To provide handy access, the double-ended drawers of this Shaker table can be opened from either side.

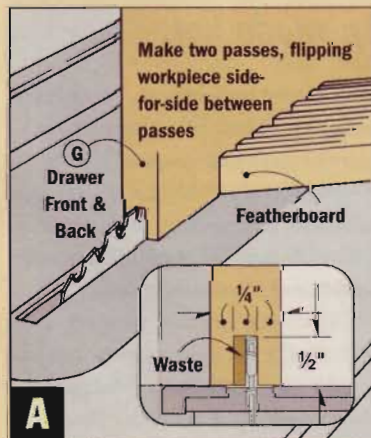

▲ On the ends of the front and back, cut a groove to form a $\frac{1}{4}$ "-wide tongue. Note: Depth of cut matches the thickness of the sides [$\frac{1}{2}$ "].

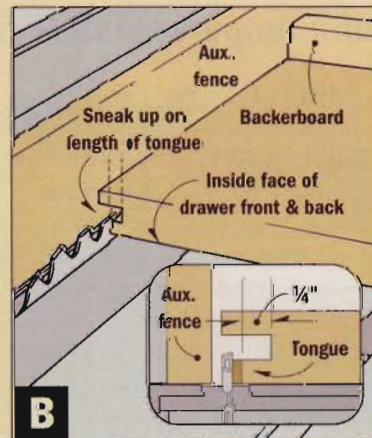

▲ To trim the tongue to length, remove a small amount from the end first. Then butt the workpiece against the fence and make a final pass.

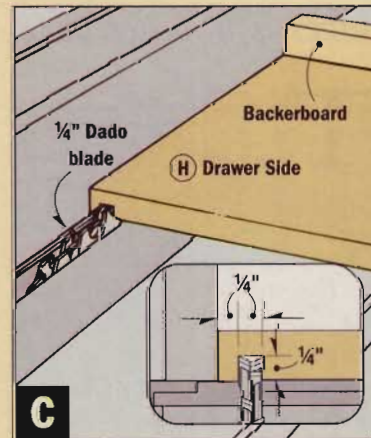

▲ Finally, mount a dado blade in the table saw and cut a dado in each side piece to fit over the tongue. (Check the setup with a test cut.)

Router Table Turning

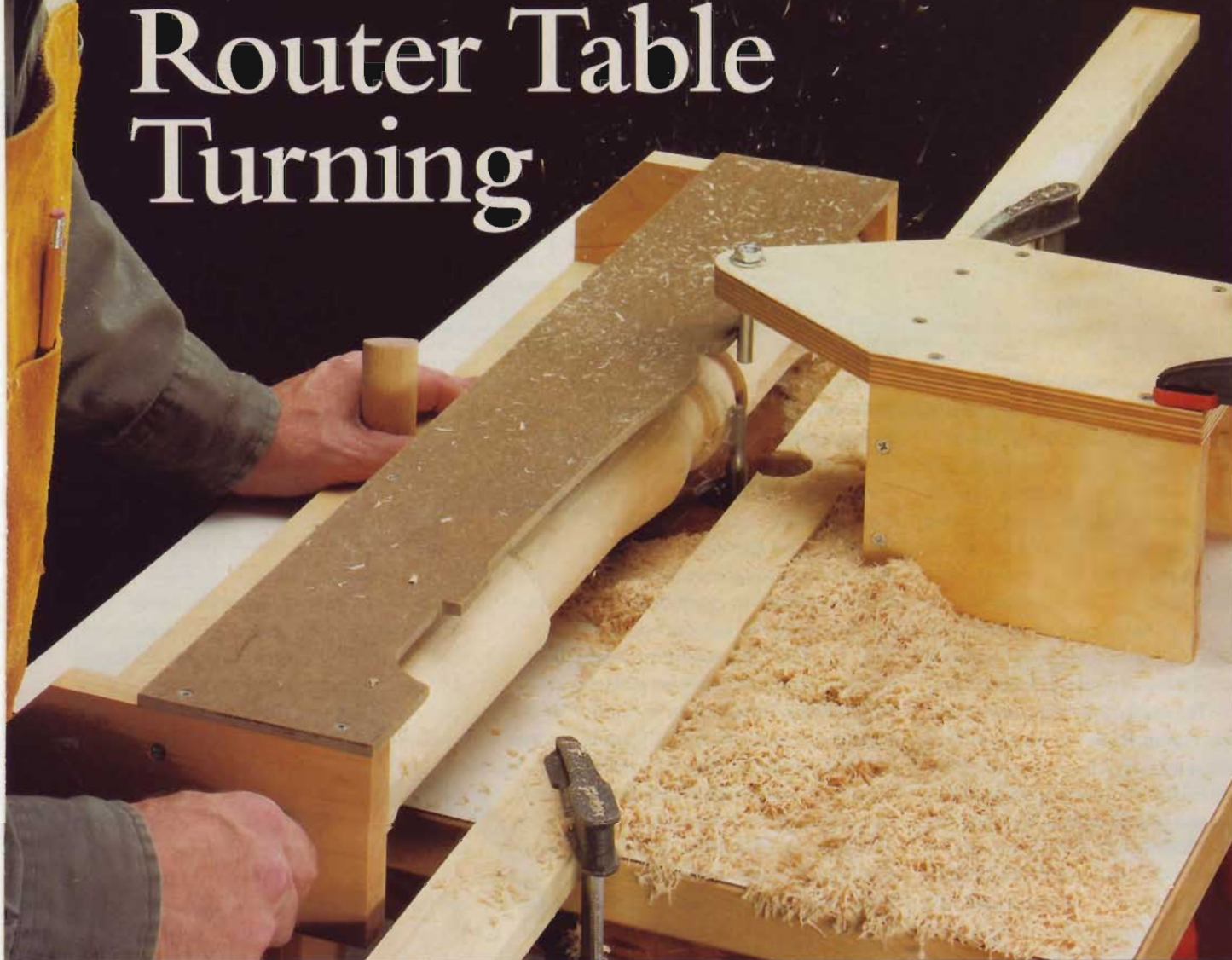

It's easy to "turn" a spindle — without even using a lathe. All it takes is a router table and a couple of simple shop-made jigs.

The router table was the center of attention in our shop recently. That's because we were experimenting with a routing technique that's a bit out of the ordinary.

This technique involves "turning" a spindle to shape on the router table. And sure enough, with a straight bit and a couple of shop-made jigs, you *can* rout a spindle easily and accurately.

To get an idea of how this works, take a look at the photo above. The spindle "blank" is mounted in a *carriage* that you slide across the router table.

Attached to the carriage is a hardboard template that matches the desired shape of the spindle. The template follows a guide pin that's mounted in a raised *platform*. The pin is the same diameter as the bit and centered directly above it. So as the template follows along the pin, the router bit cuts the spindle to match the exact shape of the template.

I used the template shown above to turn the spindle for the Shaker table (page 30). But with different templates, you can rout just about any shape of spindle you'd like.

The long board clamped to the router table is simply a scrap piece

that I used as a stop to control the sideways depth of cut when making the first few passes.

JIG CONSTRUCTION. It's easy to build the carriage and the platform. We've included illustrations and key dimensions on page 41.

The only unusual parts of these jigs are the turning centers and the guide pin. And these are nothing more than bolts with the heads cut off (which is easily accomplished with a hacksaw). One of the turning centers is epoxied into a wood dowel to form a handle. The guide pin is attached to the platform with washers and hex nuts (*Pin Detail*).

CARRIAGE & PLATFORM CONSTRUCTION VIEW

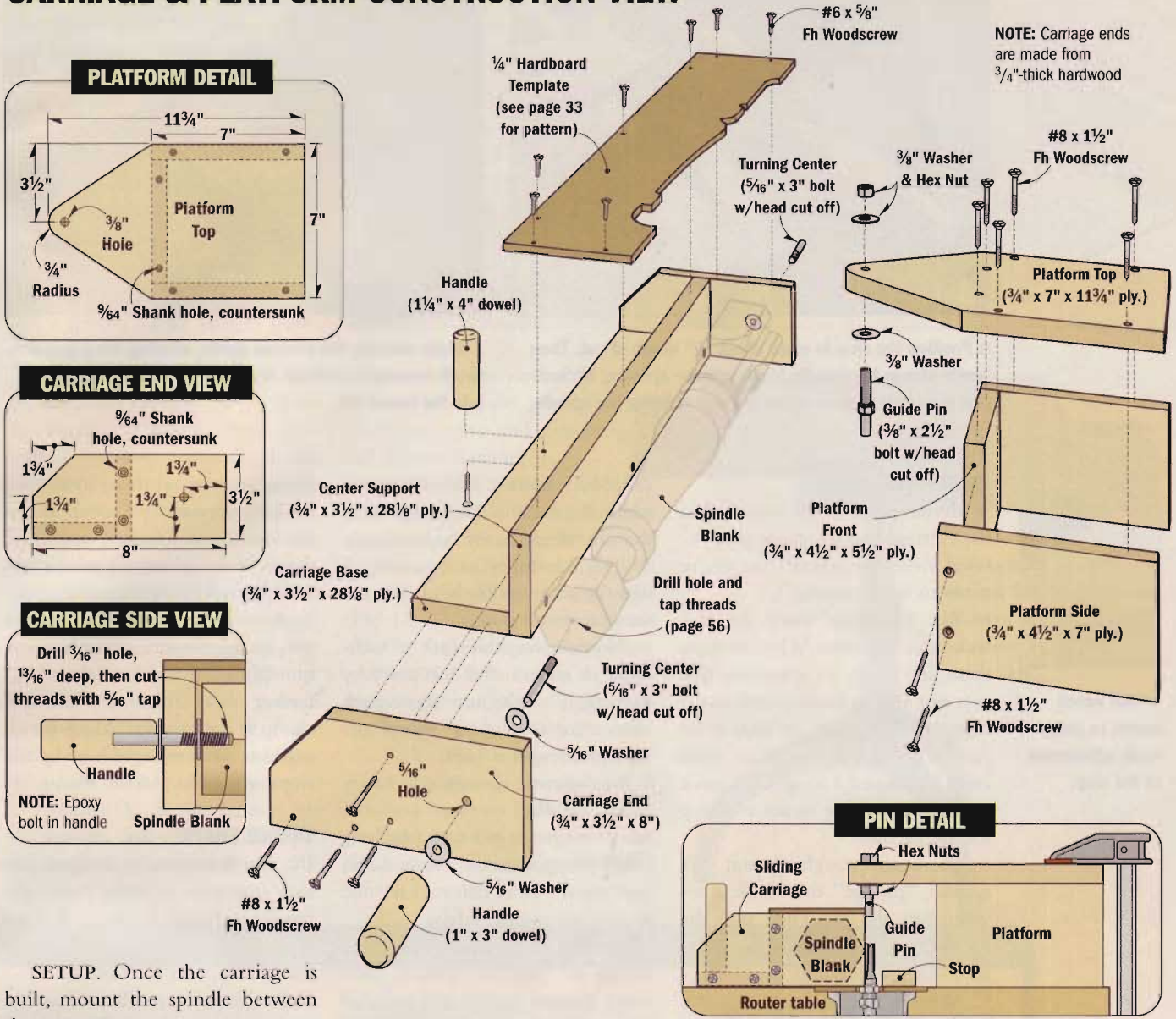

SETUP. Once the carriage is built, mount the spindle between the centers.

Note: The spindle blank will need to be drilled and tapped to accept the threaded bolts that serve as turning centers. This is also quite easy to accomplish with a standard tap-and-die set. You can see how that's done in *In the Shop* on page 56.

Now you can set up the router table. Start by centering the guide pin over the bit (Fig. 1). Check the alignment on one plane, then rotate the bit 90° and check to ensure that the bit and pin are aligned in this second plane, as well. Then clamp the platform to the table.

Finally, raise the router bit so the top of the bit is slightly above the center of the spindle blank (Fig. 2).

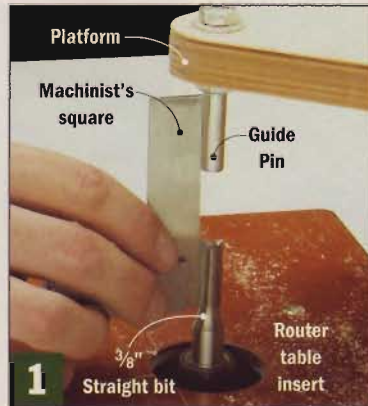

▲ Use a square to align the guide pin with the cutting edges of the router bit.



▲ With the spindle blank mounted in the carriage, raise the bit so it sticks up above the center of the blank.

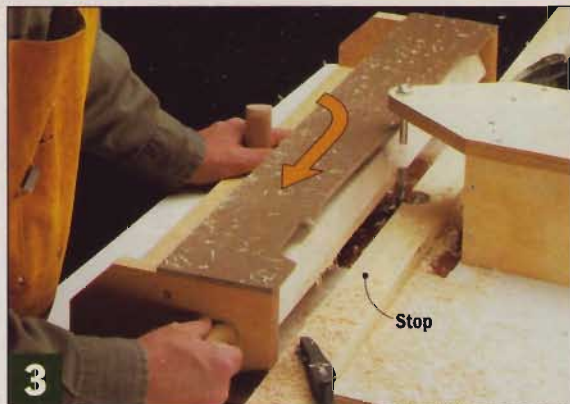

▲ Position the stop to allow about 1/4" depth of cut. Then gently plunge the spindle blank into the spinning bit and pull the carriage toward you to begin shaping the spindle.



▲ Begin shaping the grooves slowly, nibbling away just a small amount of material at a time by rotating the spindle into the router bit.



▲ Use pencil marks to gauge each adjustment of the stop.

FIRST PASS

With the spindle blank mounted in the carriage and the guide pin centered over the router bit, you're ready to start "turning."

The operative word for this technique is *patience*. When making these first passes, it's important that you not try to remove too much material all at once. In fact, to be sure I didn't cut too deep right away, I clamped a long scrap piece to the router table to act as a stop for the carriage.

To begin roughing out the spindle, "plunge" the blank sideways into the bit. Then pull the carriage toward you in about a 4"-to 6"-long stroke (Fig. 3).

Moving the carriage in this direction is actually a technique

called back routing. That's when you move the material being routed in the same direction the bit is rotating.

The benefit of back routing is that the bit is less likely to chip the workpiece and ruin it.

Nonetheless, this isn't a technique I recommend for everyday routing. There's just too much chance for the bit to "shoot" the workpiece right at you.

In this case, though, the handholds on the carriage and the added insurance of a stop (the long board clamped to the router table) gave me the extra control I needed to rout the spindle safely.

For the second pass, rotate the handle to turn the spindle. Then make another plunge cut and pull the carriage back again. Continue

along this way, working in about a 6"-long section at a time. When one section is roughed out, move down the length of the spindle and rout the next 6" section.

After you've completed the first pass along the entire length of the spindle, move the stop about 1/4" farther away from the bit and clamp it down again. Make pencil marks to keep track of how far the stop has moved (Margin Photo).

TAKING SHAPE

By the time you've nudged the stop over two or three times, the template should begin to contact the guide pin at the thickest part of the spindle, near the bottom.

At this point, you'll need to start paying close attention to the

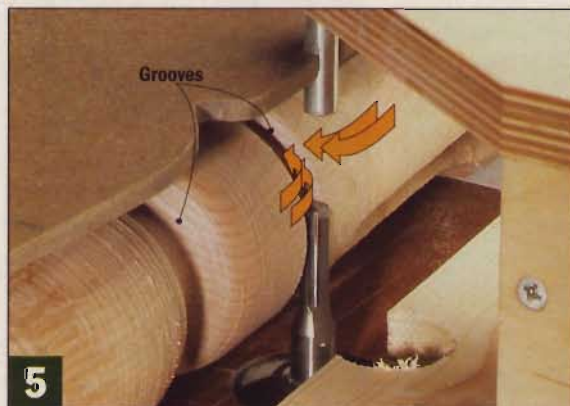

▲ As the spindle takes shape, deepen the grooves by using short strokes from both directions to ease the edges. Take your time to avoid causing any chipout.



▲ When the rough shaping is done, carefully go back over the entire spindle to remove any ridges or high points you might have missed in previous passes.



NOTE: Use miter gauge to guide carriage

▲ Square up the shoulder of the tenon by easing the spindle into the blade. Then rotate the spindle by hand.



Use drill to rotate spindle

▲ Chuck a drill onto a turning center (the one without the handle). Then use the drill to rotate the spindle as you sand it smooth with the other hand. A dowel wrapped in sandpaper fits nicely into the grooves.

grooves in the spindle. Even with the stop and the guide pin controlling the depth of cut, it's easy to let the spindle plunge too deeply at these points, which could cause chipout. The secret is to "nibble" these areas away, a little bit at a time.

To do this, position the template so the location of the groove is lined up with the guide pin. Now, ease the spindle into the bit just the smallest amount. As soon as the bit begins cutting the spindle, start rotating the handle (Fig. 4).

The goal here is to just start shaping the grooves, not to finish them just yet. To get them to their final depth and shape, you'll need to repeat this process each time you adjust the stop.

LAST PASSES

Eventually, you'll remove enough material that you can remove the stop and let the template ride along the guide pin. It's easy to rush at this point and make a mistake. So just keep taking your time as you make these last clean-up passes.

Once again, you need to be particularly careful in and around the grooves. I found that by nibbling away just the tiniest amount in these areas, I was able to shape the rounded shoulders without causing any chipout (Fig. 5).

Once the grooves are done, you can make a finishing pass to remove any tiny nubs you might have missed

(Fig. 6). And remember that the smoother you get the spindle now, the less you'll have to sand later.

At this point, the turning is complete. But it's not quite time to remove the spindle from the carriage. The next three steps are much easier with the spindle still mounted in the carriage.

FINAL TOUCHES

The router bit will leave a radius at the shoulder of the tenon. An easy way to remedy this is to use the table saw and a miter gauge to square up the shoulder (Fig. 7).

The carriage also becomes a great sanding aid by simply chucking a drill onto the turning center (Figs. 8 and 8a). Use one hand to

run the drill and the other hand to sand the spindle.

Finally, to remove the waste at each end of the spindle, head back to the table saw. Here again, use the miter gauge to guide the carriage as you ease the spindle into the blade (Fig. 9). As the blade contacts the spindle, rotate the handle slowly to cut a kerf all the way around the spindle. But don't cut all the way through the spindle just yet.

When both ends are partially cut, remove the spindle from the carriage and finish the cuts with a hand saw (Fig. 10). This will leave a small ridge on each end of the spindle. You can knock these off easily enough as part of a final hand sanding (Fig. 11).

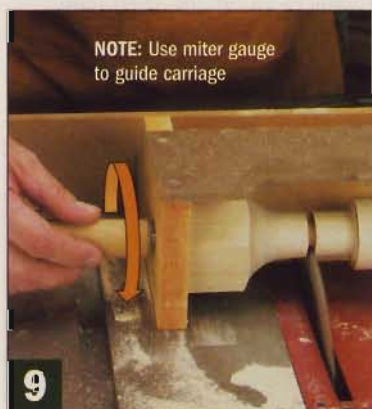

NOTE: Use miter gauge to guide carriage

▲ With the spindle still mounted in the carriage, cut part way through the spindle at each end.



Waste

▲ Remove the waste at each end of the turned spindle by completing the cuts with a hand saw.



▲ A final hand sanding will remove any imperfections and prepare the spindle to be finished.

A Fancy Finish for Figured Maple

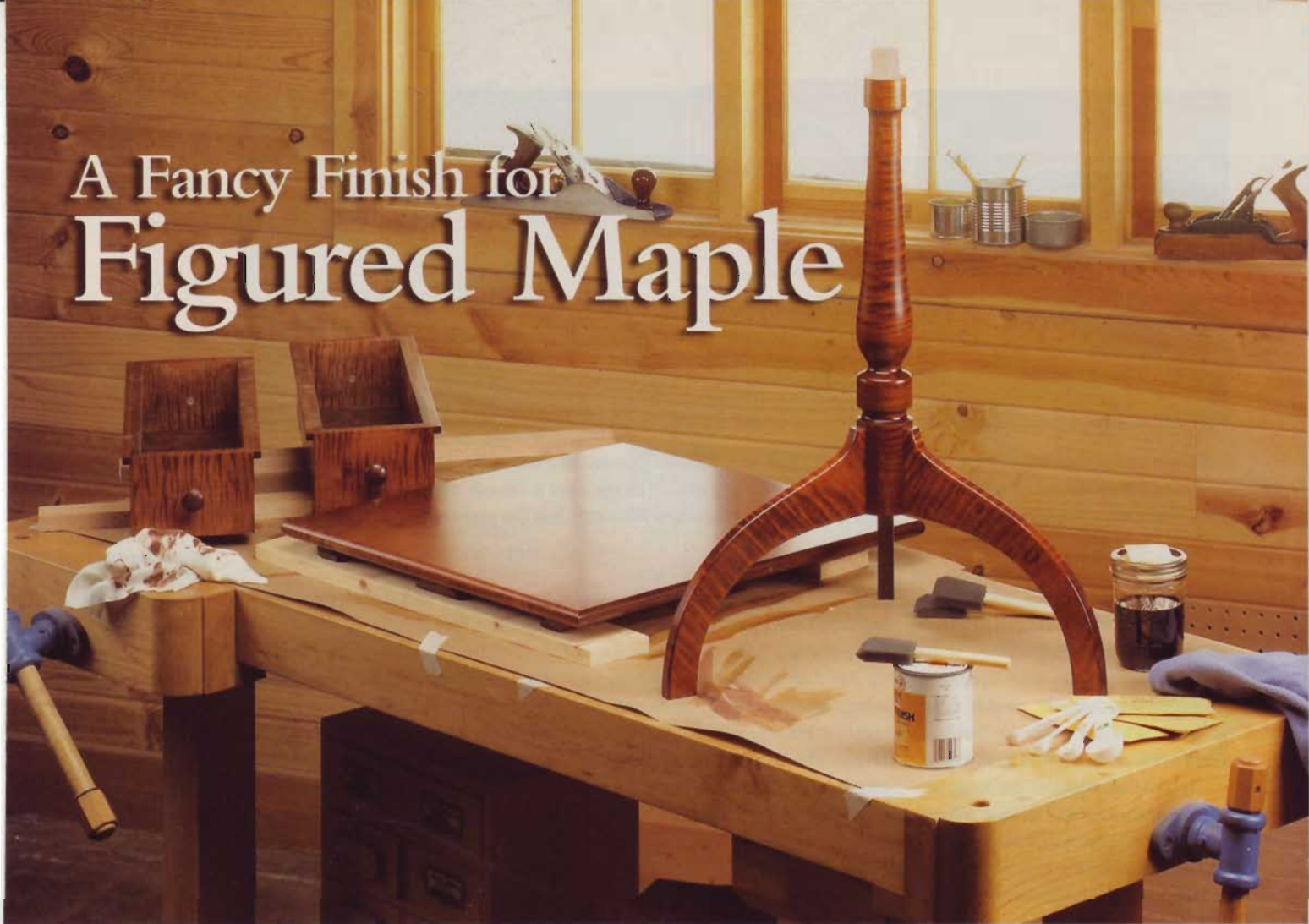

Building a special project out of highly figured maple? Bring it to life with a fancy finish. We show you how in this simple 3-part finishing technique.

When it came to finishing the Shaker-style pedestal table shown on page 30, I had two goals in mind.

First, I wanted to highlight the incredible figure of the curly maple that I used to build the table. The second thing was to create a deep, rich, reddish-brown color.

To accomplish both things, I used a three-part technique that resulted in the fancy finish shown above. This technique uses an aniline dye to color the wood and make the figure “pop,” amber shellac to protect it, and a dark wax to soften the look and feel of the wood.

ANILINE DYE. Aniline dye is a type of “stain” that produces a uniform color without covering the figure of the wood. These dyes actu-

ally penetrate the wood fibers in order to color them. This emphasizes the figure of the wood instead of partially obscuring it like the pigments in an off-the-shelf stain.

The aniline dye I used comes as a dry powder that’s dissolved in warm

water (see the sidebar on page 45). The nice thing about mixing your own aniline dye is that you can control the color and intensity of the dye.

This water-soluble dye does have one drawback, though. As the dye contacts a freshly sanded surface, the



▲ Before applying the aniline dye, lightly mist the surface of the wood to raise the grain, then let it dry.



▲ Now lightly sand the surface of the wood with 150-grit paper to knock off the raised “whiskers.”

water causes the wood fibers to swell, which makes them “fuzz.” To minimize this problem, dampen the surface of the wood and let it dry *before* applying the dye (Fig. 1). Then lightly sand it smooth (Fig. 2).

Once the surface is prepared, you can use a soft cloth (or foam brush) to wipe on the dye. To get the best results, keep the entire surface wet until it’s completely covered, then wipe off the excess before it dries (Figs. 3 and 4).

After the dye dries, the surface will appear muddy or sometimes even a different color. Fortunately, applying a top coat will restore the clear, bright color.

SHELLAC TOP COAT. To seal the wood, I used shellac for a top coat. Amber-colored shellac (Bulls Eye from Zinsser) produces a nice warm tone. And since this is an off-the-shelf shellac, there’s no need to mess with any mixing.

Just a word of caution. This shellac dries fast, so brush it on quickly. I applied three coats. Don’t worry about trying to brush each coat out smooth (Fig. 5). Sanding between coats will take care of that (Fig. 6).

PASTE WAX. The final step in this three-part finishing technique is to apply a layer of paste wax. This knocks down the gloss and softens the look and feel of the wood. I used a dark brown paste wax made by Briwax (Figs. 7 and 8).



▲ After preparing the dye, flood the surface with dye and keep a “wet” edge at all times to avoid lap marks.



▲ Once the surface is saturated, use a clean, soft cloth to remove excess dye before it has time to dry.



▲ To produce a soft, warm tone and restore the vivid color, brush on three coats of amber shellac.



▲ Let the shellac dry, then lightly sand the entire surface smooth with 320-grit sandpaper between coats.



▲ After applying the final coat of shellac, rub on a coat of dark brown paste wax to hide any tiny blemishes.



▲ Finally, buff to the desired finish with a clean, soft cloth. This softens the look and feel of the wood.

PREPARING AN ANILINE DYE

Preparing an aniline dye is as easy as making a cup of instant coffee. Simply dissolve the dye in a plastic (or glass) container of warm water. Note: Check the instructions on the package for the recommended ratio.

By mixing the dye and water in different ratios, you can change the intensity of the color. You can also create a custom color like I did by mixing different color dyes (see Recipe at right). Keep track of the ingredients.

Before applying the dye, test the color on a scrap piece of wood from the project. Just be sure to sand this scrap piece just like the project. Also, don’t forget to apply a finish so the “true” color comes out.

SOURCE: Lockwood’s Water-soluble Aniline Dye is available from the Woodsmith Store at 800-835-5084.

ANILINE DYE
Antique Maple

- 1C Warm, Distilled Water
- ¼ tsp. Knotty Pine (Golden Antique #461)
- ¼ tsp. Maple (Medium Amber #143)
- ½ tsp. Mahogany (Cuban Red-Brown #36)

DIRECTIONS: Gradually add all three dyes to warm water. Stir until dissolved, let the mixture sit for 20 min. then stir again to be sure it’s completely dissolved. Apply dye cold.

Tool Test: 16-Gauge Finish Nailers

16-gauge finish nailers are the perfect dual-purpose nailer for woodworkers and home improvers. We compare eight popular models to find the best of the class.



When we set out to evaluate pneumatic finish nailers, we quickly chose 16-gauge nailers as the category to compare. Our belief is that 16-ga. nails are small enough for most woodworking projects, but large enough for installing molding. That makes them the perfect dual-purpose nailer for the woodworker and remodeler.

Also, finish nailers in this size are made by several manufacturers, they're readily available, and very affordable when compared to even the next larger-size nailer. The nails themselves are just as available and also reasonably affordable.

So deciding which nailers to compare was easy. Figuring out how to evaluate the quality and usefulness of each nailer took a bit more time. After all, we expected every

HOW WE TESTED



▲ ACCURACY & NAILER JUMP

To measure accuracy and how far the nailers "jumped," we attempted to set a nail directly on a cross hair. Then we measured how close the nail was to the intended point.

one of these nailers would fire a nail into a piece of wood each time we pulled the trigger — and we were right.

So what separates the good from the bad? Here's how we found out.

HOW WE TESTED

To guarantee a level playing field, we connected each nailer to the same compressor with the same air hose for all of the performance tests. A pressure regulator was installed just ahead of the tool (see main Photo) to maintain exactly 90 psi. Also, the same brand of nail was used in each gun.

The most important thing we wanted our testing to reveal was how precise each of these guns were. For instance, could they be "dialed-in" to set a nail at exactly the depth we wanted — whether flush with the surface or countersunk. Also, how accurately could we position a nail? Could we get into tight corners with the nailers? We also wanted to see what kind of mark the nailers left on the workpiece. And we gave some consideration to the range of nail lengths the tools accepted.

Throughout the testing, we paid attention to see which nailers "jumped" the most, which could result in a double fire or a nasty mark on the workpiece. We also changed nails frequently to see which tools are easy to load and unload. Finally, we deliberately tried to jam the nailers to find out which ones were easy to clear.

As similar as these nail guns appear to be, our tests revealed some very important differences in the way they perform.



ONLINE Extras

- Cordless finish nailers from Senco and Paslode.
- Plus, Craftsman's combination nailer/stapler.

WorkbenchMagazine.com



▲ DEPTH ADJUSTMENT
In this test, we tried to set a nail perfectly flush to determine how adjustable the depth settings are.



▲ NOSE PAD CLEARANCE
This test showed us whether there was any interference when nailing into the contours of crown molding.



▲ NAIL SETTING
With the depth settings at "neutral," we nailed into pine and maple to see how the nailers handled different material.

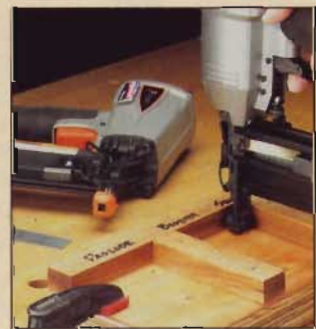

▲ CORNER TEST
Here we determined which nailers could best get into corners and hide the nails in the shadows.

4 Details That Make a Difference



DEWALT



PASLODE



SPOTNAILS



PORTER-CABLE



BOSTITCH

1 Nose Pad Sizes and Shapes

Air nailers lead with their nose. And the shape and size of the noses on these tools, as well as the non-mar pads that come standard on all but one of the nailers, is a defining characteristic among this group (see photos). A good design offers a clear line of sight for accurate nail placement. At the same time, it's important that the nose not mark the workpiece, creating a blemish that you'll have to repair later.

The best nose in the bunch is on the DeWalt. The swept-back shape of the contact trip creates a wide-open view of the workpiece underneath. The pad on the nose is a thin, hard plastic that does an excellent job of protecting the wood without blocking the view.

Another good, though very different design, is on the Paslode. What makes this design unique are the beveled edges of the pad. These make it easy to seat the pad at an angle, such as when toe-nailing or working in tight corners.

The only other standout nose is on the SpotNails. The slight profile of this nose made it very easy to place nails precisely. It also allowed the nailer to fit

in tight corners and in spaces where the large nose pads just won't go. On the other hand, this is the only nose in the bunch that didn't have a pad on it (and no visible means of attaching one). As a result, the nose did have a tendency to mark soft materials.

The nose pads on the remaining tools were large, which limited these nailers' ability to fit into tight corners and also obscured visibility. Of these, the Porter-Cable, Craftsman, and Bostitch pads offered a slightly better view and tighter fit into the corners than the large nose pads found on the Hitachi and Senco nailers.



HITACHI



SENCO



CRAFTSMAN

2 Loading/Unloading

Given the wide range of nail lengths that these nailers can fire, it's important that changing nails is as easy as possible. So while we were interested to see how easy these tools were to *load*, we were just as interested to see how easy they were to *unload*.

The DeWalt was by far the best on both counts. It was the only nailer in the bunch that we could consistently load and unload with one hand.

The Hitachi and Paslode are easy to load, but a bear to unload. The other nailers have their own idiosyncracies that, once learned, are reasonably easy to execute.



3 Nail Depth Adjustment

Since it takes more force to drive a nail into white oak than it does into a piece of pine, a nailer should allow you to change the depth setting to best match the material you're working with.

Every one of these nailers has such a device. Again, they are quite different (see photos at right).

Interestingly enough, these depth setting devices do not change the force applied to the nail, but rather change how far the contact trip stands off the end of the nose. By adjusting the setting so that the contact trip is at its furthest point from the nose, the nail should not be driven as deep into the workpiece. Or, at least that's the theory.

The one nailer that showed exceptional depth adjustment was the Senco. This gun uses a wheel type adjustment with several detents. Each detent set the nail at a different height. We were able to leave nails standing $\frac{3}{4}$ " proud of the surface or drive them as deep as $\frac{1}{4}$ " and all points in between.

Another excellent depth adjustment can be found on the Paslode.

While not having quite the range of settings that the Senco does, the Paslode could be set for several different heights. One particularly nice feature of this system is the directional arrows that make it easy to figure out which way to turn the wheel to adjust the depth.

The most unique depth setting system is on the DeWalt. Rather than the wheel that's common on the other tools, the DeWalt has a sliding lever with five detents. The system is easy enough to work. To change the setting, there's a button on the side of the tool that unlocks the slide. Set the slide in one of the detents and release the button to lock it. The slide doesn't offer the same wide range of settings that the wheel type adjustments do, but in our trials it proved to have all the adjustability we needed. And it was simple to operate.

Our least favorite adjustment is the Hitachi. This one required a wrench to loosen a bolt just forward of the trigger. Although effective, this system was the most troublesome to adjust and fine tune.



◀ The Paslode nailer has directional arrows next to the depth adjustment wheel, so there's no guessing at which way is which.



◀ DeWalt's depth stop isn't as adjustable as other systems, but it has all the range you'll need. And it's easy to use.



◀ Hitachi's depth adjustment required a wrench to make any changes. We prefer the tool-less variety.

4 Nail Jams

A jammed finish nailer isn't a common occurrence, but when it happens, you need to be able to clear the jam without disassembling the entire tool.

We fired nails into the head of a screw with the goal of intentionally jamming the nailers. We were only able to cause jams in two of the nailers this way: the Paslode and the Porter-Cable. Some of the other tools we were able to jam by purposely *misloading* nails.

The Porter-Cable cleared easily. That's due to the way the front hatch on the tool swings open to allow access to the area where jams occur. The Craftsman, Senco, SpotNails, and Bostitch, though never actually jamming, all opened in the same manner as the Porter-Cable.

The Paslode was a bit trickier to clear as the front hatch only opens about 45 degrees.

The DeWalt suffers the same trouble as the Paslode in this area, though it should be noted we had to go to great lengths to get the DeWalt to jam in the first place.

The Hitachi never did jam, though we noted that the nose opened only slightly beyond 45 degrees.



▲ Porter-Cable's nailer offers easy access for removing nail jams with a front hatch that swings well out of the way of the nail channel.

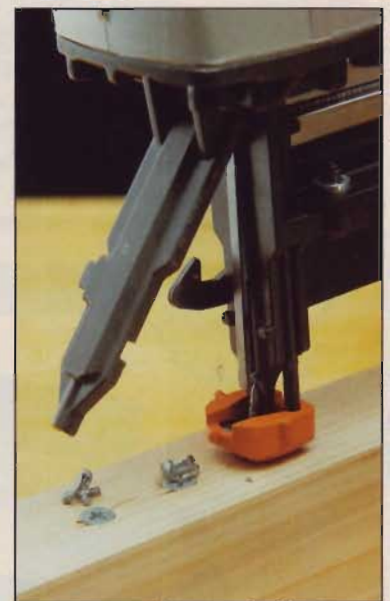

▲ The Paslode would be easier to clear if the front hatch opened up further. Also, the driver blade had to be pushed in to reset the tool.

PASLODE T250-F16



By all accounts, Paslode builds a superb finish nailer. Our testers found this gun to have several superior qualities that earned it our *Editor's Choice* award.

First, this tool is among the most compact designs — only the SpotNails was smaller. That makes

this nailer easy to fit into the tight spaces you're likely to be faced with whether building cabinets or installing trim. It also means you won't get tired of lugging it around as quickly as some of the bulkier tools in the test.

In addition to its compact size, this nailer was the smoothest operating tool we tested. It fired relatively quietly, didn't jump at all, and set nails flawlessly every time.

The depth adjustment on this nailer was also better than most, allowing us to fine-tune it to set the nail at just the depth we wanted.

Another outstanding feature of the Paslode is its unique nose pad. It's not one of the smallest, but still offers a clear line of sight for accurate nail placement.

The best thing about this nose pad, though, is the beveled shape. We noticed that the bevels made it much easier to operate the nailer at an odd angle, such as when installing

crown molding in a corner or toenailing into a tight space.

Complaints about the Paslode included difficulty unloading nails from the magazine and the otherwise excellent nose pad was large enough to interfere with placing nails tightly into a corner.



At a Glance:

Price:	\$180
Nail Size:	3/4" to 2 1/2"
Nail Capacity:	100
Fire Modes:	Sequential, Bump
Weight:	4.2 lbs.
Operating PSI:	80 - 120
Warranty:	1 year

Virtues: Smooth operation. Compact size. Beveled nose pad. Reasonable price.
Vices: Unloading nails is difficult. Nose pad is large. Small opening for clearing nail jams.
Verdict: A superior tool with all the best traits for pro or DIY'er alike.

BOSTITCH SB1664



Bostitch put all the right features on this nailer at just the right price to get our nod as a *Top Value*.

Although one of the least expensive tools in the test, this nailer is solidly built and performs well beyond its bargain price.

For instance, the depth-setting system on this nailer was fully adjustable and responsive to each small change in the setting. We were able to set nails well above the surface of the wood (though I can't imagine why you'd want to), as well as countersink nails 1/4" deep.

Once adjusted, the depth stop provided nearly identical results in a variety of soft and hardwoods. This means you won't have to mess with the settings when going from one project to another.

Firing the nailer was smooth and jump-free. A clear sight line and alignment marks on the nose pad made it easy to predict exactly where the nail was going. Loading nails was simple; unloading nails was passable. However, this gun has one of the most accessible jam clearing hatches in the group.

Our only complaint is that the nose pad is a bit oversized, which

limits the tool's usefulness in close quarters. The flat shape of the pad also kept it from fitting well into the elaborate profile of crown molding. Nonetheless, this nailer is a smart buy because of its overall quality and outstanding price.

At a Glance:

Price:	\$160
Nail Size:	1" to 2 1/2"
Nail Capacity:	100
Fire Modes:	Sequential, Bump
Weight:	4 lbs.
Operating PSI:	70 to 120
Warranty:	1 year

Virtues: Passable sight line. Highly adjustable depth settings. Excellent price.
Vices: Nose pad is large and didn't fit into crown molding well.
Verdict: A capable tool for home or professional use at a price that can't be beat.



PORTER-CABLE FN250A



This affordable nailer from Porter-Cable makes a strong case for paying a little and getting a lot. Only two other tools in this test matched the bargain price of this nailer, and few others could equal its user-friendly demeanor.

First off, the Porter-Cable is well sized. It's not the smallest tool in the bunch, but it tucked nicely



into most of the tight confines we tested it in.

We also found this tool to be extremely well built, with the best fit and finish of all the nailers we tested.

The depth setting wheel was easy to operate and very effective. This allowed us to adjust the nail setting across a wide range of depths, from sitting well proud of the surface to about 1/4" countersunk.

The medium-sized nose pad on this tool offers an excellent line of sight, and alignment marks on the pad aid in accurate nail placement. In our test to determine how well the nailers could squeeze into corners, the nose pad on this tool put it right in the middle of the pack.

For loading and unloading nails, the Porter-Cable ranked second in the group. This is a valuable trait if you undertake a variety of projects requiring various lengths of nails.

We were able to intentionally jam this nailer during our tests, but

found that the front hatch of the tool opens up to allow plenty of space for easy jam clearing.

Overall, the Porter-Cable is a well-balanced nailer that performed commendably without drawing any significant complaints from the testers.

At a Glance:

Price:	\$160
Nail Size:	3/4" to 2 1/2"
Nail Capacity:	100
Fire Modes:	Sequential, Bump
Weight:	4.25 lbs.
Operating PSI:	70 to 120
Warranty:	1 year

Virtues: Effective depth adjustments. Medium-sized nose pad. Decent sight line. Front hatch accommodates easy jam clearing. Outstanding price.

Vices: No significant complaints.

Verdict: A reliable, no-nonsense tool that's value priced.

DEWALT D51256K

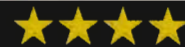

The DeWalt nailer is clearly a professional-grade tool. It's priced a bit higher because of that, but it has several features that justify the extra cost, depending on your needs.

First of all, this tool has the best nose design, hands down. The swept-back contact trip offers a wide-open view of the workpiece

underneath. And the no-mar pad, which is virtually invisible from the operator's perspective, grips the workpiece well, even when toenailing. This slim design also allowed the nailer to fit into corners better than the other nailers.

Additionally, the DeWalt boasts enormous nail capacity — 160 nails compared to the 100 that's typical of this group. All that capacity does require a long magazine, though. And our testers were split as to whether having to reload less frequently is worth the extra length.

The magazine itself is nylon instead of the metal magazines on the other tools. The advantages of the nylon are less overall weight and a magazine that flexes instead of bending if it gets stepped on or dropped (and yes, those happen enough to be important).

Depth setting on this nailer was also unique. It uses a vertical slide

with five indexed positions. It's an easy system to operate, but the slide doesn't offer as much adjustability as some wheel-type systems.

Ultimately, the high price kept this tool from earning a top spot.

At a Glance:

Price:	\$200
Nail Size:	1 1/4" to 2 1/2"
Nail Capacity:	160
Fire Modes:	Sequential, Bump*
Weight:	3.9 lbs.
Operating PSI:	70 to 120
Warranty:	1 year

Virtues: Superior nose design. Loads/unloads effortlessly. Easy depth adjustment. Lightweight.

Vices: Limited range of depth adjustment. High-priced. Large size.

Verdict: Pro-grade tool that may be worth the high price to some.

*Firing modes are changed by changing triggers. Both triggers are included.



SENCO FINISH PRO 32



The Senco nailer had several features that impressed us during our performance testing. For instance, it demonstrated the widest range of adjustment in depth setting among this group of nailers. It operated smoothly and quietly, and it set nails cleanly.

Unfortunately, it also had a few shortcomings that caused us to move it down the list.

First of all, the depth adjustment had to be changed between hardwood and softwood — the only nailer in the bunch that required this. The nose pad on this tool is also quite bulky, which created a poor line of sight and made precise setting of nails a bit challenging. Additionally, the padded grip on this tool was tearing by the time our test concluded.

At a Glance:

Price:	\$160
Nail Size:	1¹/₄" to 2¹/₂"
Nail Capacity:	110
Fire Modes:	Sequential, Bump
Weight:	4 lbs.
Operating PSI:	70 to 120
Warranty:	1 year

Virtues: Smooth operation. Wide range of depth adjustment.

Vices: Required frequent depth setting adjustments. Large nose pad restricts sight line.

Verdict: A middle-of-the-road nailer at a reasonable price.

HITACHI NT65A2

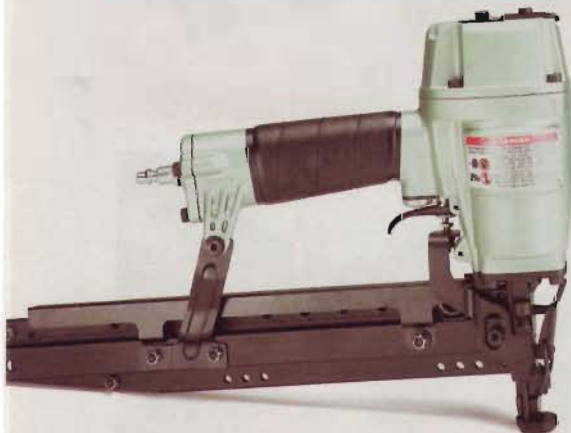

Hitachi's nailer is a rugged, high-capacity tool with a disposition for mass production.

The heaviest tool of the bunch, this nailer holds a lot of fasteners and is capable of firing them much faster than most DIY'ers would care to. The tradeoff is that it takes a firm grip to control the jump when the gun is fired.

Considering how large and heavy this tool is, we can't recommend it for hauling around the job site. It seems best suited to a "set-it-and-forget-it" environment, such as a production cabinet shop. This is especially true when you consider that changing the depth setting requires a wrench.

This is not a bad tool by any means. But it's specialized and expensive.

At a Glance:

Price:	\$210
Nail Size:	1" to 2¹/₂"
Nail Capacity:	150
Fire Modes:	Sequential, Bump
Weight:	4.6 lbs.
Operating PSI:	70 to 120
Warranty:	1 year

Virtues: Large nail capacity. Rugged construction. Rapid cycling.

Vices: Expensive. Heavy. Wrench required for depth adjustments.

Verdict: Perfect for production shops. Look elsewhere for a DIY finish nailer.

SPOTNAILS WB1650



The unusual look of this nailer appealed to some testers more than others. But on the points that truly matter, most agreed that this is a decent tool — with a few weaknesses.

What we can't forgive about this nailer is its exorbitant price. Although the nailer fired flawlessly, loaded and unloaded easily, and is the most compact, lightweight tool we tested, the price tag is just too high.

Also working against this tool is an inflated nail capacity claim (SpotNails lists nail capacity as 150, we could only squeeze in 104). Another downfall was this tool's lack of a nose pad. The nose marked nearly every workpiece we nailed.

At a Glance:

Price:	\$235
Nail Size:	1" to 2"
Nail Capacity:	150*
Fire Modes:	Sequential
Weight:	3.5 lbs.
Operating PSI:	80 to 100
Warranty:	1 year

Virtues: Small. Lightweight. Easy loading/unloading.

Vices: Expensive. Nose marks.

Verdict: Not a bad tool, but nowhere near worth the price.

*We were only able to load 104 nails.

CRAFTSMAN 18441



At a Glance:

Price: \$180
Nail Size: 1 1/4" to 2 1/2"
Nail Capacity: 160
Fire Modes: Sequential, Bump
Weight: 7 lbs.
Operating PSI: 70 to 110
Warranty: 1 year

Virtues: Large nail capacity.
Vices: Between two nailers, we were unable to find one that performed well enough to even consider purchasing this tool.
Verdict: Cannot recommend this nailer at any price.

Although nearly a twin to the Bostitch on the outside, there is something quite different going on *inside* the Craftsman.

We tested two Craftsman nailers for this review. The first one worked relatively well with the exception that the depth adjustment wheel had no impact on how the nail was set. We were curious if that was a fluke or a common characteristic, so we purchased a second nailer.

The second was worse than the first. Besides no depth setting control, it had the unpleasant habit of firing two or three nails at a time. In between clearing jams, we also noticed that nails had a tendency to fall out of the gun. Stay away from this one.



Final Recommendations

Editor's Choice: Paslode's T250-F16 "nailed" the top spot with a tool that is compact, fires smoothly and quietly, and is easy to use.

The unique nose design and outstanding depth setting characteristics give this tool just enough advantage to pay the extra \$20 over the next two contenders.

Top Value: The Porter-Cable FN250A and Bostitch SB1664 finish nailers parallel each other in both price and performance.

Both operate trouble-free, have easy, effective depth adjustment features, and do a better than average job of getting into the spaces where finish nailers need to go. Either tool is money well spent.

If we had to choose one over the other, the slight advantage would have to go to the Bostitch for its better sight line, lesser tendency to mark a workpiece, and the fact that we weren't able to make the nailer jam.



Porter-Cable
FN250A

Bostitch
SB1664

Paslode
T250-F16

FINISH NAILER REPORT CARD

Model	Ergonomics	Nose Pad		Sight Line	Depth Setting	Accuracy/Jump	Marking	Loading	Unloading	Jam Clearing
		Size	Shape							
Paslode	B+	A	A	B+	A	A	A-	B	C	B
Bostitch	B+	B	B	A	B	B+	A	B	B-	A
Porter-Cable	B+	A	B	A-	B	A-	B	B	C	A
DeWalt	B	A+	A+	A	C	B-	A	A	A	A-
Senco	A+	C	A	C	A+	B	A	A	B-	A
Hitachi	B	B-	C	A-	D	C	A	B	B	A
SpotNails	B	N/A	N/A	B	B-	A	D	B	B	A
Craftsman	B	B	B	C-	F	C	C	A	B-	A

In the Shop

Tapping Threads in Wood

The spindle for the Shaker table (page 30) is turned to shape using a shop-made jig on the router table (page 40). To mount the spindle blank in the jig, I needed to drill and tap threads in each end of the blank (see Photo).

To tap the threads, start by drilling a centered pilot hole in the blank. This hole is $\frac{1}{8}$ " smaller than the tap to provide enough material to form the threads. As for depth, drill $\frac{1}{8}$ " deeper than the threaded portion of the hole. You don't want the tap to bottom out.

Once the pilot hole is drilled, center the tap in the hole (Step 1). The tip of the tap is

slightly tapered to help center it. Also, notice that the first few threads are flatter than the others to avoid cutting the threads at an angle.

With the tap centered in the hole, twist it slowly and evenly, rotating it in a clockwise direction (Step 2). At the same time, apply a small amount of downward pressure. Once you start to feel some resistance, turn the tap counter-clockwise to back it part way out of the hole (Step 3). This will clear the wood chips out of the threads you just cut.

To finish tapping the threads, repeat twisting and backing off the tap (Step 4).



▲ A T-handle makes the tap easy to turn. Notice also how the tip is slightly tapered to help center the tap in the pilot hole. Taps are available at most hardware stores.

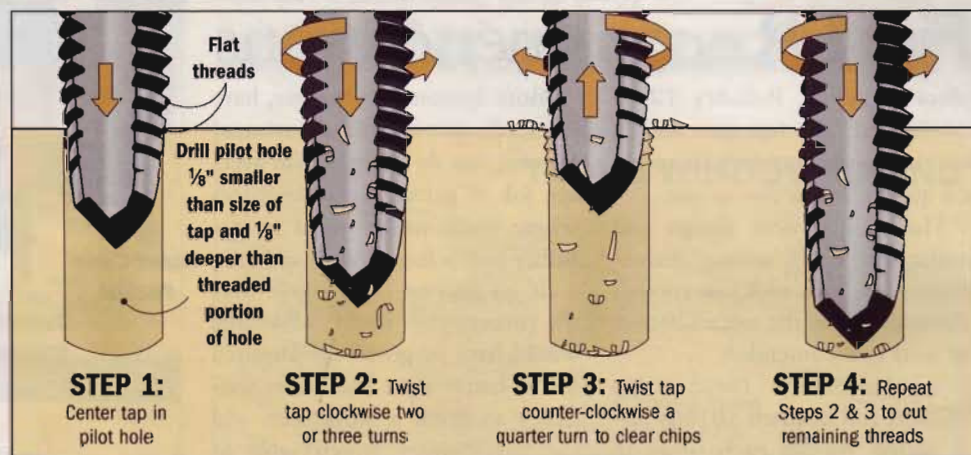

Shop-made Sanding Block Solves Edging Problem

The biggest challenge in applying solid-wood edging to any project is sanding the edging flush with the surface of the plywood

— without sanding through the thin veneer. So when it came time to attach and sand the edging on the built-in bookcases (page 19), I made a simple sanding block that solves the problem. This block let me sand precisely on the top of the edging — not on the plywood (see Photo at left).

To make this work, the sanding block needs to be the same thickness as the edging. Then to prevent the block from tipping and rounding over the edging, I glued on a $\frac{1}{4}$ "-thick plywood guide, as shown at left. Now attach a narrow strip of self-adhesive sandpaper to the bottom of the block.

To use the sanding block, hold the guide firmly against the edging. Then slide the block back and forth to sand the edging flush with the plywood.

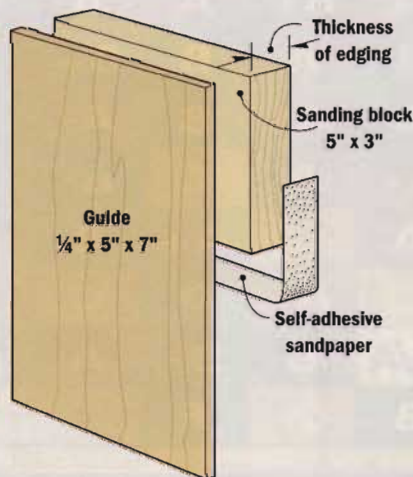

Cradle Those Fidgety Pipe Clamps

While gluing up the face frame for the built-in bookcases on page 19, I faced the old problem of getting the pipe clamps to sit still while positioning the frame.

This time, though, I found a solution. To hold the clamps in the "ready" position and make it easier to tighten them, I made two sets of cradles. Each cradle is a small

tapered block with a curved notch to hold the clamp. A short pin (dowel) fits into a hole in the clamp to keep it from rotating in the cradle (*Detail a*).

To make a pair of cradles, start with two 6"-long 2x4s (*Detail b*). Then drill a 1" centered hole through each block. Next, use a band saw to crosscut the block through the center of the hole.

Now taper the long edges. The next step is to drill a hole in each cradle and matching holes in the pipe clamps. Finally, tap a pin (1/4" dowel) into the hole in each cradle.

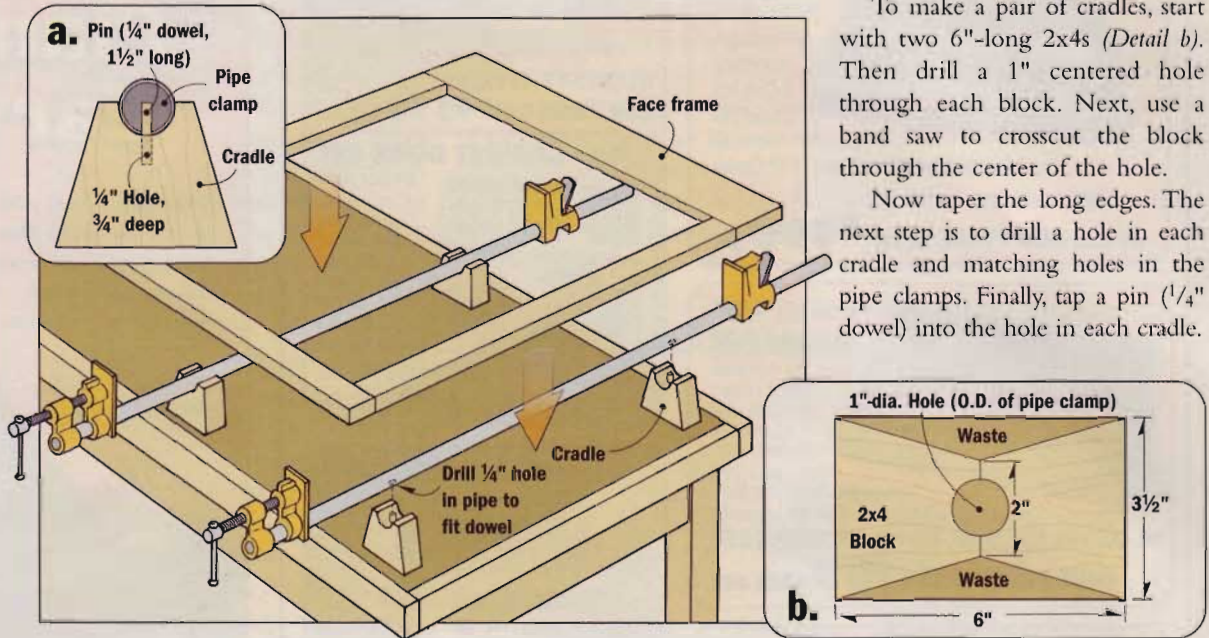

It's The World's Only Cordless Brad Nailer That's Also Pneumatic.

Cordless. Pneumatic. Our new cordless brad nailer gives you the option of both, using exclusive *TPS Technology™* (*Twin Power Source System*). It's cordless,



thanks to a mini-compressor powered by our rechargeable, interchangeable 12-volt battery. It's also pneumatic, courtesy of a 1/4" valve that allows you to use it with traditional

compressors. To get one of your own, visit your Porter-Cable dealer or call 1-800-487-8665

(519-836-2840 in Canada).



PORTER-CABLE
PROFESSIONAL POWER TOOLS

Product Information Number 177

Sanding a Solid-wood Panel Flat

One of the quickest and most effective ways I know to flatten a glued-up, solid-wood panel is to use a belt sander. This involves a three-step process.

MARK HIGH SPOTS. The first step is to locate the “high” spots. To do this, set a straightedge on the panel and shine a light underneath it (Fig. 1). The light will be visible in the low areas. Now use a pencil to mark the high spots.

SAND ACROSS GRAIN. Once you’ve marked all the high spots,

it’s time to remove them. To begin, mount an 80-grit sanding belt. Then place the sander flat on the workpiece with it turned off.

Now turn the sander on and move it back and forth across the grain over the pencil marks (Fig. 2). This way the sander rides on top of the high spots and quickly grinds them down. Although it’s tempting to apply downward pressure, let the weight of the sander do the work instead. All you need to do is guide the sander as it “floats” across the

surface. Just be sure to keep the sander flat and moving all the time. Once all of the pencil marks are gone, turn the sander off and check your progress using the straightedge and light again.

SANDING IT SMOOTH. The final step is to remove all of the cross-grain scratches. To do this, mount a 120-grit belt and sand the entire surface *with* the grain. Any really fine scratches that remain after belt sanding can be removed with a finish sander or by hand.

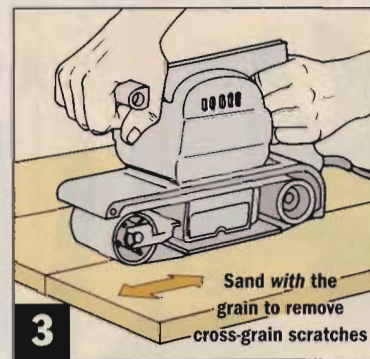
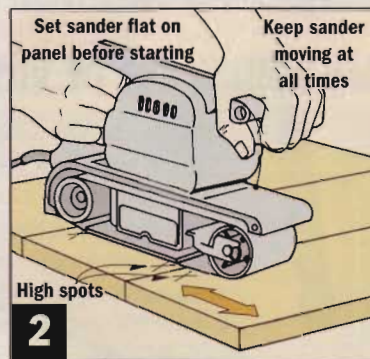
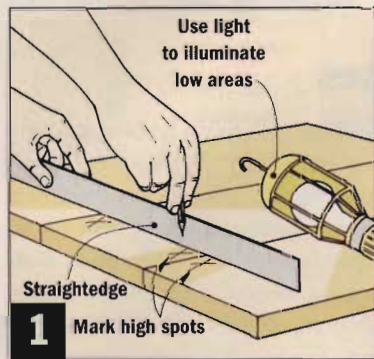

It's The World's Only Pneumatic Brad Nailer That's Also Cordless.



Pneumatic. Cordless. Our new cordless brad nailer gives you the option of both, using exclusive *TPS Technology™* (Twin Power Source System). It's pneumatic, courtesy of a 1/4" valve that allows you to use it with traditional compressors. It's also cordless, thanks to a mini-compressor powered by our rechargeable, interchangeable 12-volt battery. To get one of your own, visit your Porter-Cable dealer or call 1-800-487-8665 (519-836-2840 in Canada).

Proud sponsor of
THE NEW YANKEE
WORKSHOP on
Public Television



PORTER-CABLE
PROFESSIONAL POWER TOOLS

WWW.PORTER-CABLE.COM



20 GREAT GIFTS UNDER \$20

From a “groovy” push stick to knockout knee pads, cable “handcuffs” to a super-sized shop scooper, here are 20 great stocking stuffer ideas.

A Vise with a Lot of Virtues



1 The Vise-Grip Toolbox (\$19.98) is built around the traditional locking pliers that are Vise-Grip’s hallmark. But there’s a lot more to this multi-tool that makes it a good gift idea. For starters, it comes equipped with a wire cutter, wire stripper, scraper blade, and a knife blade with both a razor-sharp edge and a serrated edge. Plus, a holder locks at 90° and 180° and accepts slotted and #2 Phillips head screwdriver bits. In the spirit of giving, you also get three extra bits. Source: Available at most home centers

ProjectCalc Makes Math Easy

2 Who wouldn’t love finding a ProjectCalc (\$19.95) in their stocking. The ProjectCalc does it all — from figuring out how much paint or wallpaper you’ll need, to converting odd decimals to fractions, to calculating board feet and adding fractions. A quick reference guide makes it handy to measure in feet, inches, or cubic yards. You can even convert to metric dimensions. Source: Home centers and hardware stores

Pocket-size Tool Pouch



3 The Rear Guard (\$13) from Bucket Boss makes a perfect stocking stuffer that actually stuffs in your pocket. It has a padded flap that fits inside a back pocket perfectly and a snap loop that hooks to a belt. Four pockets provide a surprising amount of space for stowing tools. There’s even a clip loop to keep your tape or keys close at hand. Source: Visit Bucket Boss’s Web site at BucketBoss.com to find the nearest retailer, or call 800-289-8288.





This Bar Bites Like a Shark

4 The Shark Grip (\$19.99), manufactured by the Shark Corporation, is like getting two gifts in one. It's a miniature pry-bar and a nail puller. The slightly curved, wafer-thin blade works great for easing off moldings and trim without marring the wall. The 2"-wide blade also doubles as a scraper. Then turn it around and use the head to pry out small finish and headless nails. I've even used the flat back of the head as a hammer in a pinch. Plus, at only 10" long, the Shark Grip is easy to carry and fits neatly in a tool box.

Source: Duluth Trading Co., 800-505-8888, or check out duluthtrading.com

Now That's Square

5 No "wish list" would be complete without at least one engineer's square on it. These extremely accurate squares (often within .002") are of particular value in setting up workshop power tools — table saws, jointers, or any machine that requires precision cuts. Plus, it fits easily in an apron. You can buy engineer's squares from 2" up to 8" (\$7 to \$17) at most woodworking stores and home centers.

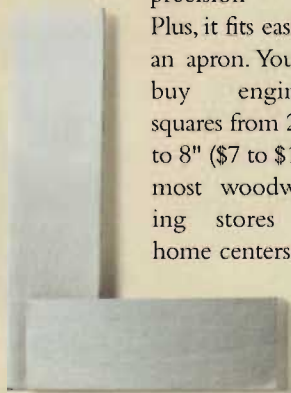

Screw Extractors

6 This three-piece Screw-Out set from Craftsman (\$19.99) earns a spot in your stocking because they work better than any other screw extractors I've found. They dig into damaged heads and yank out screws faster than a dentist pulling teeth.

Source: Sears stores, Sears.com

Fat Max Tape Measure "Rules"

7 The 25' Fat Max tape measure (\$17.84), manufactured by The Stanley Works, is a great gift idea for two reasons. First, the blade extends up to 11 ft. without bending or collapsing. No other tape measure boasts this much standout. The second reason has

to do with the durability of the blade. The 1"-wide blade is reinforced with a special coating to reduce breakage. This also means the large, easy-to-read numbers are more resistant to wear.

Source: Home centers and hardware stores

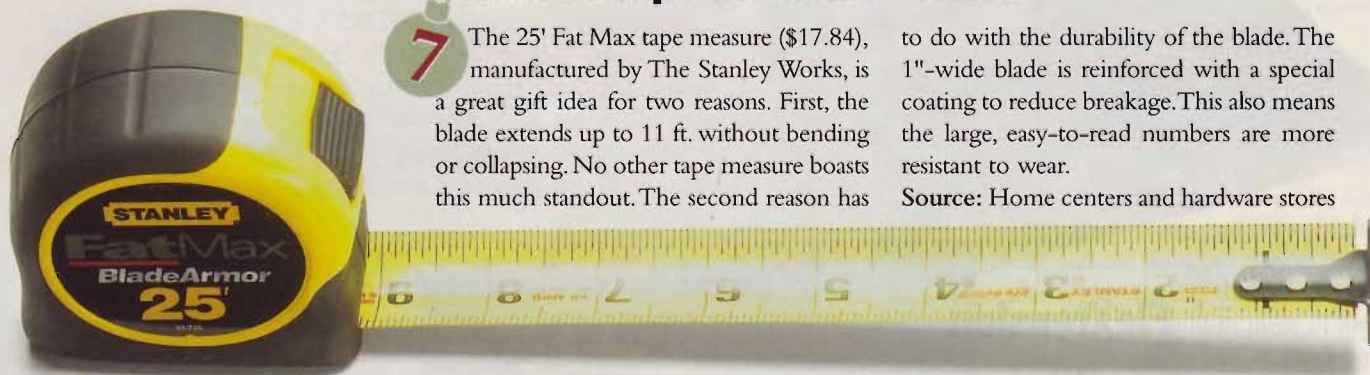

2-in-1 Knockout Knee Pads

8 These GelTek kneepads with Quick Swap (\$19.99) feature a soft inner lining for comfort and a durable shell that absorbs shock. But what really makes them different than other gel kneepads is a unique system that lets you change pads. A smooth hard cap is designed for tasks that require sliding or shifting. Then when you need added traction, say on a slippery roof, simply unbuckle and hook on the all-terrain cap.

Source: Sears stores, Sears.com



Shed Light on Finding Studs

9 The Zircon Stud-Sensor Pro SL (\$19.98) is light years ahead of the competition for locating wall studs. As you slide the sensor along the wall, it beeps once you reach the edges of the stud. Then to truly eliminate any guesswork when marking the stud location, the sensor also projects a SpotLite on the wall over the stud. Source: Home centers and hardware stores





Right On the Mark

10 You can't

beat an Incra 6" Bend Rule (\$17.99) for making accurate measurement marks along the edge of a workpiece. That's because the rule has a series of precision slots and holes cut through it at $\frac{1}{16}$ " and $\frac{1}{32}$ " increments. Simply line it up and mark it with a mechanical pencil. It also stands upright for easy viewing.

Source: Woodcraft, 800-225-1153 or woodcraft.com

Miter Saw Makes the Cut

11 This small miter saw (model #64005) manufactured by Jorgensen (\$19.99) is big on features. For starters, the saw slides smoothly with very little play thanks to a pair of plastic guides. Six pre-set angles from 15° to 90° let you quickly make accurate right and left cuts. The saw even converts to a conventional handsaw. Other handy features include a pair of screw holes that let you mount the saw securely to your bench, and an easy-to-read scale that indicates the miter angles.

Source: Adjustable Clamp Co., 312-666-0640



Super-Sized Shop Scooper

12 This 14"-wide Shop Scoop (\$18.99) isn't going to fit in any Christmas stocking, but it still makes a great gift. The "overgrown dustpan" holds a heap of sawdust in a single scoop. Plus, the enclosed back also lets you clean up liquids. The Shop Scoop even has a large, comfortable handle and features galvanized steel construction for durability. Source: Woodworker's Supply, 800-645-9292, or go to the company's Web site at woodworker.com



FleXtension

13 This snake-like driver bit extender from Fuller Tools twists, turns, and bends to let you drive screws in tight spaces where other screwdrivers and power drivers won't go. Yet, it lets you keep a firm, steady grip on the tip of the extender while the inside drill mechanism rotates. At \$7.99, it's gift money well "bent." Source: Woodcraft, 800-225-1153, woodcraft.com; or Rockler, 800-279-4441, Rockler.com

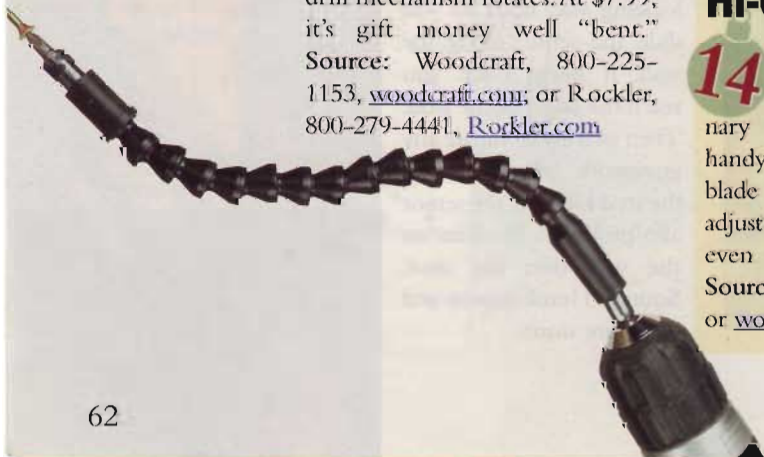

Hi-Gage Gauge

14 The Hi-Gage (\$19.99) accessory converts an ordinary combination square into a handy setup tool. Use it to set blade heights on your table saw, adjust bit height on a router table, even measure drilling depths. Source: Woodcraft, 800-225-1153 or woodcraft.com

Folding Sport Blade

15 This Stanley SportUtility Knife (\$19.96) switches freely from utility work to a rugged sport blade with the flick of a thumb. A tough serrated edge, comfortable grip, and nylon sheath all combine to make the SportUtility an ideal gift idea for sportsmen on your list. Source: Home centers





Painting a Perfect Edge

16 Frustrated with having to tape around trim to get a neat, clean paint line? Shur-Line (a division of Newell Rubbermaid) has you covered with the Trimline Edger (\$8.97). A metal guide on the roller lets you paint right up against trim and into corners, so there's no need to tape. The guide protects the trim against paint squeeze-out, and it even rotates so you can paint on the right or left of a door or window.

Source: Most home centers and hardware stores



Flat Sole
V-groove Sole



"Groovy" Stick with Sole

17 Two gifts for the price of one (\$19.99). That's what you get with the Power-Hands Push Stick, featuring two interchangeable rubber pads. Fit the firm, flat traction pad onto the push stick for table saw or jointer work. Then when you're ready to rout and shape, simply replace the flat traction sole with the second pad that has a special V-groove shape. Another convenient feature of this push stick is the large handle. It's comfortable, and it keeps your hand well away from the bits and blades.

Source: Woodworker's Supply, 800-645-929, woodworker.com

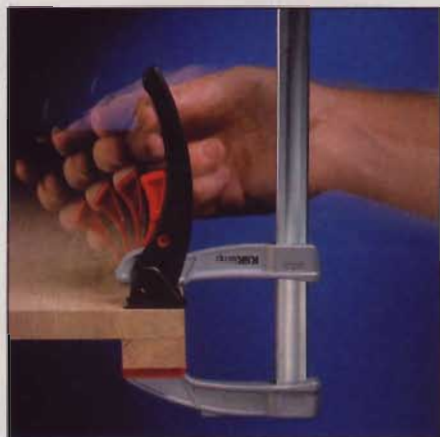

One-handed Wonder

18 The Bessey KliKlamp from the American Clamping Company is handy to have around. That's because it's strong, lightweight, and convenient to use. Like many other fast-action clamps, the new KliKlamp lets you apply clamping pressure easily with one hand. What really sets this clamp apart from others is its innovative ratcheting system. Each time you click the handle, the clamp ratchets tighter. This means it doesn't take much force or cranking to apply a lot of clamping pressure. The clamp is great for holding jigs in place or to quickly secure a workpiece to your drill press table or benchtop. The non-mar jaws even grip round or odd-shaped items. Priced at only \$19.99, you can give a KliKlamp to every woodworker on your list.

Source: Most woodworking stores and catalogs

Drill & Drive in the Fast Lane

19 This Drill and Drive Set from The Stanley Works (\$12.97) lets you drill a hole and drive a screw in a matter of seconds. It consists of a special holder that houses a double-ended bit. To lock the bit, just click down on a metal collar on the holder. Then drill the hole, flip the double-ended bit around, and drive in the screw. The set includes the holder, nine bits, and its own carrying case.

Source: Home centers



"Cuffs" for Cords

20 Organizing power cords and keeping them from getting tangled up couldn't get much easier than using Cable Cuffs. Simply slide one of the handcuff-like devices around each cord and lock it in place. When it's time to use the cord, the Cable Cuff unlocks with the push of a button.

Source: Home centers (from 69 cents up to \$1.49)





Tools & Products

Jet Unveils New "Super" Table Saw

It's clear from the way Jet named this saw — The SuperSaw — that they are quite proud of their new tool. And they should be. This 10" table saw is the latest entry into the category of saws that falls somewhere

between contractor saw and cabinet saw. But more than just join the fray, Jet has successfully raised the bar for this new category.

Among the outstanding features on this table saw are:

- Large, solid cast-iron extension wings
- A powerful, 1³/₄-hp motor
- Micro-adjustable rip fence with T-slots for mounting jigs and hold-downs
- A large, lighted power switch that can be positioned anywhere along the front rail
- A deluxe miter gauge with extruded aluminum fence and adjustable stops
- Optional cast-iron sliding cutoff table

That really is the "short list" of highlights for this saw, which is available in four different packages. Depending on whether you need 30" or 52" of rip capacity, or add the sliding cutoff table, expect to pay between \$850 to \$1,300 for The SuperSaw. For a complete list of the features on this table saw, visit www.JetTools.com.



▲ Shown here is one of several variations of Jet's new SuperSaw. This model features a 52" rip fence with a wood extension table and steel support legs.

Ridgid Adjustable Caster Set

Ridgid's new Herc-U-Lift PLUS adjustable frame caster set is a new and unique solution to the chore of having to move heavy tools around the shop.

The Herc-U-Lift is intended for tools with open bases and footprints from 24" to 32" square. It's rated to carry as much as 300 lbs. The caster set is specifically designed to work with Ridgid tool stands, but can be fitted to other open stands by drilling mounting holes in the legs.

With the Herc-U-Lift attached to a tool base, raising the tool is simply a matter of stepping on the pedal. Then the four swiveling casters allow you 360° of mobility to steer the tool around the shop. Once the tool is in position, step on the pedal again to lower the tool back onto its own feet.

One particularly nice feature of this caster set is that it's contained entirely within the tool base. That means it won't take up valuable floor space when it's sitting or snag everything you try to roll it past.

Ridgid's Herc-U-Lift PLUS is available at Home Depot for \$99.

▼ Ridgid's new Herc-U-Lift PLUS mobile tool base is convenient, compact, and can be fitted to most open stands.



Porter-Cable's 8529

Porter-Cable revamped and renamed their popular 7529, 2-hp plunge router to introduce the new 8529. Along with the name change come a couple of worthwhile improvements.

First is an above-the-table adjustment system. It works with a hex-shaped dial that reaches through the router table top. (Porter-Cable's 698 router table, shown here, comes with a pre-drilled hole; you'll have to drill one in your own table). The dial allows for adjustments as precise as 1/128".

The elaborate power switch has also been replaced by a simple toggle switch that's positioned within easy reach of the operator's thumb. The router will still be priced under \$220.

► Porter-Cable's new 8529 plunge router is right at home in a router table thanks to a feature that lets you raise the bit through the table.





Ryobi "Six Pack" With Rolling Storage Case

Ryobi's new Six Pack 18-Volt Combo Kit is a cordless workshop on wheels. The kit includes these tools:

- ① 8 1/4" Compound Miter Saw with 40-tooth blade and extension wings
- ② Speed Saw with 1/8" and 1/4" bit capacity, spindle lock, and circle-cutting guide
- ③ Reciprocating Saw with variable speed trigger and tool-less blade change
- ④ 5 1/2" Circular Saw with an overmold grip handle and spindle lock
- ⑤ 1/2" Drill/Driver with magnetic tray, two built-in levels (one of which is detachable), 24-position clutch, two-speed gear box, and keyless chuck
- ⑥ Flashlight with adjustable head

Power is supplied by three batteries and a one-hour diagnostic charger. The entire kit fits into a roll-around storage case with a flip-over, lock-down lid that doubles as a miter saw stand. The front panel of the case has built-in blade and bit storage.

The Six Pack is available at Home Depot for only \$399.



▲ A roll-around cart doubles as a miter saw stand thanks to a flip-over, lock-down lid. Pull-out trays offer easy access to the tools.

17,000 Reasons to Own

15,000 Brad Nailing Jobs

1,160 Spraying Jobs

840 Cut Outs



ZERO BREAKDOWNS*

The Most Important Reason of All

For the ultimate in durability, all Campbell Hausfeld air tools are Built To Last. And the fact that they provide the ultimate in versatility doesn't hurt either. You can do an amazing amount of projects from woodcutting, nailing, or finishing with our air tools. These tools are Built To Last, so you can count on them 17,000 times. And beyond!

*Campbell Hausfeld stands by its reputation for quality and durability subject to conditions of our one, two, or three-year limited product warranties. Usage claims are estimates based upon product review and analysis.



Visit www.chtools.com/tools to get a free catalog and join the Powered Equipment Club for special offers. Call toll-free: 1-866-CHTOOLS (1-866-248-6657)



Skil Circular Saws Light the Way

Skil Power Tools has introduced four new circular saws with a host of innovative features. Shown here is the model 5700 Skilsaw, which features Skil's new on-board SiteLight. The light illuminates the cut line for better visibility in low-light situations. And to make it easier to follow the illuminated cut line, the saw also has a flip-out sight line extender called the AccuSight. This feature makes getting the cut started in a straight line much easier. Essentially, it provides a second reference point in addition to the standard sight line on the shoe of the saw.

The 5700 is powered by a 13-amp, 2.6-hp motor and sells for around \$80. Other less-powerful models are available for as little as \$40.

The **ARROW** X Machine ETFX50™

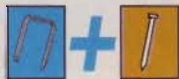

XTRA HEAVY DUTY
Professional

XCEPTIONAL COMFORT
Cushioned Grip

XPERT PERFORMANCE
Drives 6 Different Size
Staples + Nails

XTRAORDINARY POWER
14 Amps of Surge Power

XCITING DESIGN
New Ergonomic Styling



... It's what
you've come to
XPECT from Arrow!



Keeping America Strong

Available at home centers, lumberyards, and fine hardware stores wherever professional tools are sold!



Arrow Fastener Co., Inc., 271 Mayhill Street, Saddle Brook, New Jersey 07663
Canada: Jardel Distributors, Inc., 6505 Metropolitan Blvd. East, Montreal, Quebec H1P 1X9
Arrow Fastener (U.K.) Ltd., Unit 5 ZK Park, 23 Commerce Way, Croydon CR0 4ZS, Surrey, United Kingdom
www.arrowfastener.com ©2002 Arrow Fastener Co., Inc. Rev 702

Black & Decker's BullsEye Laser

Black & Decker's new BullsEye Laser Level and Stud Finder may be the most useful consumer-grade laser product we've seen this year. And we've seen plenty.

What makes the BullsEye unique is that it's self-leveling and comes with a hanging pin. Most of the other laser alignment tools out there require you to carefully level the tool as you mount it. And how you mount it is up to you to figure out.

With the BullsEye, simply push the hanging pin through the center of the tool and it levels itself. The laser casts a line in both directions, visible up to 50 feet when used with special cones (which are included).

Additionally, the BullsEye has a built-in stud finder, which comes in handy when using the laser to align cabinets or other heavy objects. The laser level and stud finder sells for around \$70.

Hanging Pin



◀ A self-leveling laser, built-in stud finder, and easy mounting make the BullsEye from Black & Decker a great choice in consumer-grade laser tools.



Handcrafted Harmony

Like luthiers of the past, a patient craftsman designs stringed instruments with a distinctive sound.

In the music industry, Tim Thelen has carved a name for himself building and restoring finely crafted stringed instruments. You'll find his custom guitars in the hands of such notable musicians as blues legend Bo Ramsey and Mike Watt, the forefather of punk rock bass guitarists.

A former guitar player turned maker, Tim understands the value of building a quality instrument that's meant to be played *and* is easy to repair.

"All of my custom guitars are first and foremost working tools," he says.

To achieve this delicate balance between beauty

and playability, Tim carefully selects each piece of wood. He then shapes and thins the pieces until they're flexible, using traditional hand carving tools and scrapers.

Like music itself, much of Tim's work is done by intuition — and never rushed — something he learned to appreciate early on as an apprentice for a German master violin-maker. Even the nitrocellulose lacquer he uses for a finish is allowed to cure for a month before it's buffed and polished to a glass-like surface.

During that month, Tim savors the anticipation of stringing up each new guitar.

"That's when the instrument really takes on a life all of its own," he says.

www.ThelenGuitars.com