

A Magazine Committed to Finding the Better Way to Build
Filled with Good Craftsmanship, the Best Techniques and No Ads

WOODWORKING

MAGAZINE

Stickley Tile-Topped Plant Stand

3 Methods to Make
Through-Mortises

Better Ways to
Cut Crisp Chamfers

The Right Way to
Use Grain Fillers

Why You Should
Sand Your Finish
Without Sandpaper

Saddle Squares –
Buy a Nice One
(Or a Butt Hinge)



POPULAR WOODWORKING PRESENTS

fw F+W PUBLICATIONS, INC. US \$5.99 CAN \$7.99

85



0 74470 01355 6

Display until March 15, 2009

Contents

“Nequeo monstrare, et sentio tantum.”
(“I cannot describe it, I can only feel it.”)

— Juvenal, late 1st-century Roman satirist

1 On the Level

Pretty is as pretty does when it comes to vintage tools and furniture – and pretty is oftentimes pretty useless.

2 Letters

Questions, comments and wisdom from readers, experts and our staff.

4 Shortcuts

Tricks and tips that will make your woodworking simpler and more accurate.

6 Make Clean Through-mortises

Woodworkers expect this joint to be tidy and tight, not ragged and gappy. We explore the best ways to make this sometimes-vexing hole.

10 Gustav Stickley Plant Stand

Building a piece that focuses on existing skills can help you refine your techniques while producing high-quality work.



MAKE CLEAN THROUGH-MORTISES: PAGE 6



HANGING SHELVES: PAGE 22



SADDLE SQUARES: PAGE 26

18 Improving Small Chamfers

We investigate several methods to make precise small chamfers on end grain, then share our results and favorite techniques.

21 Glossary

Woodworking’s terminology can be overwhelming. Learn the terms used in this issue.

22 Hanging Shelves

On this simple project, practice perfecting authentic details as you produce a handsome and useful display.

26 Saddle Squares

This little-known layout tool may change the way you work immeasurably (and you might already have one in your hardware drawer).

28 A Super Smooth Surface

Grain fillers can level open-grained wood in a single step and save time when it comes to building up a beautiful finish.

30 Sanding Finishes

Improper sanding can ruin a carefully wrought finish. Here you’ll find out how to avoid problems, and discover a few new products.

32 Reviving Techniques Forgotten (and Gross)

Our forebears wasted little when it came to woodworking – find new (old) uses for spittle, earwax and more.

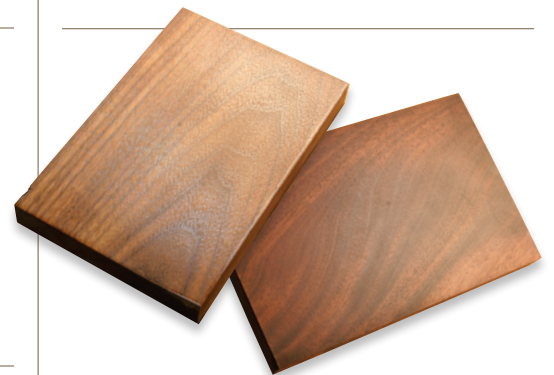

A SUPER SMOOTH SURFACE: PAGE 28



SANDING FINISHES: PAGE 30



PUBLISHER & EDITORIAL DIRECTOR

■ Steve Shanesy

x11238, steve.shanesy@fwpubs.com

EDITOR ■ Christopher Schwarz

x11407, chris.schwarz@fwpubs.com

ART DIRECTOR ■ Linda Watts

x11396, linda.watts@fwpubs.com

SENIOR EDITOR ■ Robert W. Lang

x11327, robert.lang@fwpubs.com

SENIOR EDITOR ■ Glen D. Huey

x11293, glen.huey@fwpubs.com

MANAGING EDITOR ■ Megan Fitzpatrick

x11348, megan.fitzpatrick@fwpubs.com

ASSOCIATE EDITOR FOR THE WEB ■ Drew DePenning

x11008, drew.depenning@fwpubs.com

PHOTOGRAPHER ■ Al Parrish

F+W PUBLICATIONS, INC.

David Nussbaum ■ CHAIRMAN & CEO

Phil Graham ■ SENIOR VP, MANUFACTURING & PRODUCTION

Barbara Schmitz ■ VP, MANUFACTURING

John Lerner ■ EXECUTIVE VP, INTERACTIVE MEDIA

Mike Kuehn ■ VICE PRESIDENT IT, CIO

F+W PUBLICATIONS, INC.

MAGAZINE GROUP

David Blansfield ■ PRESIDENT

Sara DeCarlo ■ VP, CONSUMER MARKETING

Tom Wiandt ■ DIRECTOR, BUSINESS PLANNING

Sara Dumford ■ CONFERENCE DIRECTOR

Linda Engel ■ CIRCULATION DIRECTOR

Susan Rose ■ NEWSSTAND DIRECTOR

Vicki Whitford ■ PRODUCTION COORDINATOR

SUBSCRIPTION RATES: A year's subscription (4 issues) is \$19.96. In Canada: Add \$5 for postage & handling (includes GST/HST). Outside the U.S. and Canada: Add \$10 for postage & handling and remit payment in U.S. funds with order.

NEWSSTAND DISTRIBUTION: Curtis Circulation Co., 730 River Road, New Milford, NJ 07646

POSTMASTER: Send all address changes to *Woodworking Magazine*, P.O. Box 420235, Palm Coast, FL 32142-0235. Canada GST Reg # R122594716.

SUBSCRIPTION SERVICES: Subscription inquiries, orders and address changes can be made at woodworking-magazine.com (click on "Customer Service"). Or by mail: *Woodworking Magazine*, P.O. Box 420235, Palm Coast, FL 32142-0235. Or call toll-free 1-800-283-3542 or 386-597-4322. Include your address with all inquiries. Allow 4 to 6 weeks for delivery.

BACK ISSUES: Back issues are available. For pricing information or to order, call 800-258-0929, visit our web site at woodworking-magazine.com or send check or money order to: *Woodworking Magazine* Back Issues, F+W Publications Products, 700 E. State St., Iola, WI 54990. Please specify *Woodworking Magazine* and issue date.



Highly Recommended

Roy Underhill's new book "The Woodwright's Guide: Working Wood with Wedge & Edge" (UNC Press) is his best yet. With beautiful illustrations and literate text, Underhill both illuminates history and teaches traditional hand skills. This book examines traditional woodworking crafts and shows the evolution of skills from the feller in the forest to the cabinetmaker in the city. Read a full review on our blog.

— Christopher Schwarz

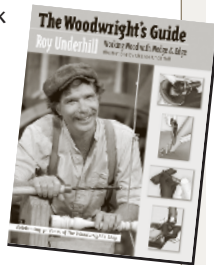

On the Level

Pretty, Stupid

I have a shiny bronze edge plane perched on my bookshelf that's nestled in an attractive red velvet bag. Wait, let me clarify that. It's actually a plane-shaped object. The thing couldn't cut its way out of a wet paper bag.

The plane's adjuster is hopelessly coarse, the iron is warped like a potato chip, and the tool's integral fence isn't 90°. But it is a pretty thing and visitors often pick it up to admire it.

Me, I hate the plane, but I keep it around to remind me not to be such a crow – a hoarder of bright and shiny objects. It's a lesson that I apparently needed to learn.

When I first started buying vintage hand tools I went for the ones that looked new. And if the tool was still in its original box, even better.

I soon discovered that often there are reasons a tool has survived for 100 years with nary a blemish or chipped handle. Sure, sometimes you get lucky and you stumble on a perfectly preserved tool that was put away new and forgotten.

But more times than not, vintage tools in pristine condition are usually the victims of poor design or faulty manufacturing.

I have a gorgeous jointer plane with a rear tote that is designed to come loose after 15 minutes of use – no matter how tightly you screw the tote to the body of the plane. I have a pristine bird-cage awl that hurts your hand every time you use it. I have a marking knife that slips from your fingers like a watermelon seed no matter how tightly you squeeze it.

In the category of tools that were made by a drunk monkey, I have a jack plane with a sole shaped like a banana. I have a gorgeous hammer with its original handle rotated about 5° off from its head. And I have a brace (it was still in the original wrapper!) with a pad that wobbles like a newborn's oversized noggin.

On the other hand, there is my Stanley Type 11 No. 5 handplane. I bought the thing at a flea market for just \$12 – the hippie selling it normally dealt in books and was tired of toting the thing from show to show.

The tool had been repainted. The rear tote had been replaced with a somewhat-crude shop-made

handle. The metalwork was a dull battleship gray. But if I ever enter a handplaning contest, that's the tool I'm going to bring along. I swear the thing is haunted. Despite its dowager appearance, the tool is unerringly precise and stable. It will be the last tool I sell when I am penniless and hungry.

These principles of buying tools also apply to furniture. Too often I encounter products that are dresser-shaped objects or table-shaped objects. Just like the tools, these things (I hate to call them furniture) are the victims of poor manufacturing, poor design or both.

In fact, when I look at old furniture, I am now drawn to pieces that are well-worn but still sturdy. Case-in-point: My wife and I used

to haunt an antiques store stuffed with European imports. We always walked past the pristine and imposing bureaus to wander among the French farmhouse tables with worn edges

and scarred tops. The fact that these tables had survived so much use and abuse was more impressive than any finial or carved knee block.

So no matter how much my daughters scratch the dining table, I refuse to refinish its top, though it would take only an afternoon to restore. I allow my tools to patinate (though not to rust). On one of my brass-walled planes you can clearly see the whorls of my fingerprints.

These are the marks that these objects were useful in life, as telling as the lines in our faces that show up from smiling or frowning a lot.

And when I pick up that bronze edge plane, I do my share of both smiling and frowning. I frown because I spent \$85 on something that's as useful as a rock for building nice furniture. And I smile because the company that made this object in the 1990s is now out of business. So perhaps there is hope. **WM**

"Tools were made and born with bands, every farmer understands."

— William Blake (1757 - 1827)

English poet, artist, engraver and publisher



Christopher Schwarz
Editor

Does Powered-up, Traditional Woodworking Exist?

Christopher Schwarz's recent article on building a traditional blanket chest (Summer 2008, Issue 10) was excellent. I was surprised, however, that he used a router to create the curves on the feet of the plinth. If it's tradition you seek, why not reach for a spokeshave or rasps?

I hope you guys will craft an article that identifies traditional joints that you can and cannot do with power tools (not just routed vs. hand-sawn dovetails). What are the hard choices that today's "traditional" woodworker has to make in order to achieve the traditional look given all of the bit, blade and machine choices – including custom-order items – out there today? Is the business of antique reproduction still all hand-planes and wood rasps? What if strict timelines and tight budgets are only secondary concerns? Is there such a thing as a powered-up, traditional woodworker?

Skye Cooley
Spokane, Washington

Skye,

These are all good questions and suggestions.

In the case of the blanket chest, the curve was too tight for any spokeshave except a cigar shave (which I do not own).

And because this piece has a contemporary look (with the box joints and clear maple finish), I decided that the feet needed to have the machine-like crispness and regularity offered by a routed pattern.

Of course, I made the pattern itself with rasps, so I guess there might just be such a thing as a powered-up hand-tool woodworker.

Christopher Schwarz, editor

Drill Press Screw Extraction

Tube screw extractors are valuable tools, but they can't be used in a drill press (as was printed in Autumn 2008, Issue 11).

The reason is that the teeth are designed to cut while the bit is turning counterclockwise. There is, of course, a logic to this design. The idea is that the bit will "hole saw" down around the broken screw until it gets enough of a grip on it to back the remaining engaged threads out. Your illustration, which I suspect was developed from a photograph, clearly shows the counterclockwise tooth design.

No single-spindle drill press that I've seen has the capability of running in reverse.

Mark Bouquet
Burlingame, California

Mark,

You're correct that the teeth on a tube extractor are created to cut while turning counterclockwise. But it is possible to use this tool in a drill press because the teeth also cut while rotating clockwise – much like handsaws that will do some cutting on the return stroke. Keep your press's speed slow and your extractor will work as described.

Glen D. Huey, senior editor

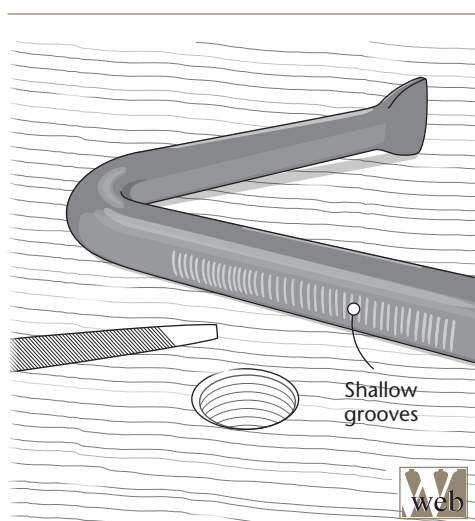

Shallow Grooves Make Holdfasts Hold Fast in 3/4" Holes

I thought I'd drop you a line concerning my eventual success using the Gramercy holdfasts in my new Holtzapffel bench (Autumn 2007, Issue 8). I built the bench using Southern yellow pine and used the 24" Veritas twin-screw vise for the face vise. I drilled the benchtop and leg holes all 3/4". I was very disappointed when the Gramercy holdfasts wouldn't "hold fast" in the top or leg holes. I tried roughing the holdfasts with #80-grit sandpaper, but they still held poorly. I then got out my mill file and filed a series of very shallow grooves along small parts of the circumference of the holdfast about 1/16" apart.

The grooves were filed in the rear of the holdfast near the top, and on the front near the bottom where they would be in contact with the bench-

top when placed under stress. The holdfast now works perfectly; it holds very well and releases easily when whacked on the back. I had considered drilling some 11/16" holes because of the problems others had reported. With this simple modification I see no reason to drill anything but the 3/4" holes that are compatible with more bench accessories. My only regret concerning the bench is that I didn't order the wooden screws.

On an additional note, Lee Valley now has a product called "bench anchors" that are useful for securing bench accessories to benches with 3/4" holes. I made a modification to that device, too. The 1/2" screws that secure your accessories to the anchors work well. My modification, however, makes them even more versatile.

I drilled a hole down the center of the 1/2" screw to allow an Allen wrench to be placed through the screw to loosen the anchor without having to remove the anchor from the accessories. This allows me to make a planing stop that I can drop into its holes and then simply tighten both Allen screws to secure it – no loose parts, no two-step assembly. The 1/2" screw is plenty big to allow for the hole and still have adequate strength.

Michael Baker
Winston-Salem, North Carolina

When Rising Water Threatens, Magazines Must be Saved!

I watched nervously as tropical storm Fay filled up the lake in my backyard quicker than the drainage system could remove it. When the water reached within a foot of the berm, I told my wife to pack whatever was important to her in the event we had to evacuate. If the water crested the berm, our way out would be flooded! Like a good wife, she packed family photos, important papers and my daughter's most-loved stuffed animals. I, on the other hand, packed my handplanes, chisels and saws. What also made its way into the van was my hardbound copy of the first seven issues of *Woodworking Magazine* and the subsequent four issues.

Fortunately, the rain slowed, the lake receded and we didn't have to evacuate. I've lived in Florida most of my life, and this was the first time I was forced to make a grab-and-run decision. I'm lucky enough to have a wife who'll do the right thing. It gives me the freedom to choose the less-than-right thing.

When faced with it, the quality of *Woodworking Magazine* made it important enough for me to save. I assume my issues could have been replaced; however, their loss would have been a loss to me. Additionally, I have a new appreciation for the printed word as opposed to the digital word. When the power is out and the battery dies in your laptop, pdfs are really hard to read!

Bill Killingsworth
Jacksonville, Florida

A Green Alternative to WD-40

In one of the letters in the Summer 2008 issue of *Woodworking Magazine* you mention the use of WD-40. In these eco-friendlier times, I have an alternative for you. Last year while shopping for milk paint at the Homestead House Paint Company (homesteadhouse.ca) I came across BioD-42, a hemp-oil-based product from a company called Hempola (hempola.com). It performs well. It cleans metal, stops squeaks and displaces moisture – plus it's biodegradable!

Michael Wirth
Toronto, Ontario

Just Plane Sore (At Us)

I am very excited about being a new subscriber to *Woodworking Magazine*. I have been following your articles and blogs and have taken a liking to your way of woodworking.

But I have to let you know that I did call you bad names this morning.

I am building a small toolbox that has hand-cut dovetails. I had some nice 12"-wide walnut and I did not want to cut it and reglue the stock just to be able to run it through my 6" jointer. So I thought, "Well Chris used handplanes to flatten his workbench, so I will do that. Heck, my boards are only 30" long and 12" wide, so how bad can it be?"

I grabbed my No. 7½ jointer plane and went to work on flattening the front and back panels. Two hours later the boards were dead flat and smooth. I had shavings everywhere and I was sweating! I put my tools away and headed to the house. All was well – so far.

"He that gives good advice, builds with one hand; he that gives good counsel and example, builds with both; but he that gives good admonition and bad example, builds with one hand and pulls down with the other."

— Francis Bacon (1561 - 1626)
English lawyer and philosopher

I woke up this morning and I could not lift my arms. It hurt to raise them at all. My wife asked me what was wrong. I said I was trying to follow Chris Schwarz's methods and my arms are killing me from planing. She laughed! I told her: "If I get pulled over by the police today and they tell me to put my arms above my head, I'm going to tell them that I can't and to just go ahead and shoot me."

Jeff Jackson
Fort Wayne, Indiana

Jeff,
You'll toughen up. It happens fairly quickly. You start using your long leg muscles instead of your arms. Planing never wears out my arms now – just my legs.

Christopher Schwarz, editor

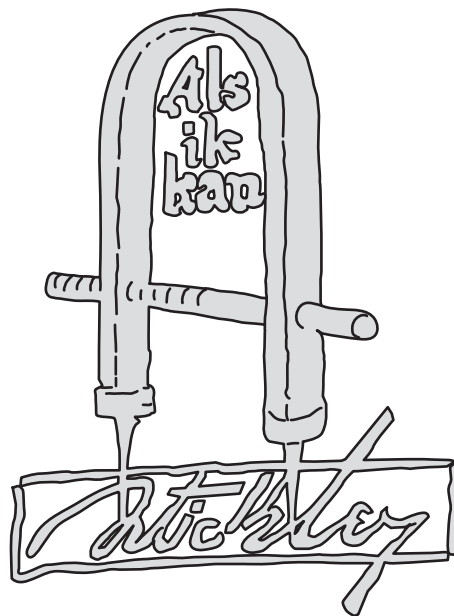

What's With That Story Title?

Just before returning to the Netherlands, I picked up a copy of *Woodworking Magazine's* Summer 2008 issue. Thank you for a great magazine. I am about to add a subscription to my list!

Just a question: What's with the title of Christopher Schwarz's article on page 32: "Als Ik Kan"? I am all for keeping readers interested and on their toes, but will they get this one?

Sjoerd van Valkenburg
Netherlands

Sjoerd,
"Als Ik Kan" (which translates, as you know, to "as best I can" or "to the best of my ability") is a Flemish phrase that Gustav Stickley adopted from the writings of William Morris and incorporated into The Craftsman logo, along with the medieval joiner's compass. It's a fairly well-known saying in the U.S. woodworking community – especially among Arts & Crafts aficionados.

Megan Fitzpatrick, managing editor

Will a Vertical Position Work For a Twin-screw Vise?

I'm preparing to build my first serious workbench based on the Roubo (Autumn 2005, Issue 4), and after agonizing over the style of vise to put where the leg vise goes, a thought entered my brain. Would it be functionally feasible to mount a Veritas twin-screw vise vertically as the leg vise? And would it prevent racking? Or is the idea ludicrous and using the traditional leg vise a simpler device that provides the same result?

Rob Crowson
Saxtons River, Vermont

Rob,
You can indeed do that. You could even mount a quick-release vise on its side for much the same effect. The only real downside to these ideas is the expense. One of the great merits of the leg vise is its inexpensive design and robust nature. It's an amazingly good value.

I've been using my leg vise for more than three years now and would not trade it. The occasional stooping is a minor inconvenience for its remarkable holding power.

Christopher Schwarz, editor

Why No Drawer Kickers in The Hanging Cupboard Design?

In looking at the plans for the hanging cupboard (which I like a lot) in the Autumn 2008 issue of *Woodworking Magazine* I noticed that there are no kickers or stops for the drawer.

Were these typically not included in this type of cabinet, is it just to keep the project simple, or is that sort of thing so basic that we're supposed to infer their presence?

Chris Friesen
via e-mail

Chris,
The middle divider works fairly well as a kicker for the drawer – though it's not perfect.

Feel free to add both. I kept them out of the project for one of the reasons you mentioned – keeping it simple for a small drawer. **WM**

Christopher Schwarz, editor

HOW TO CONTACT US



Send your comments and questions via e-mail to letters@fwpubs.com, or by regular mail to *Woodworking Magazine*, Letters, 4700 E. Galbraith Road, Cincinnati, OH 45236. Please include your complete mailing address and daytime phone number. All letters become property of *Woodworking Magazine*.

Shortcuts

ILLUSTRATIONS BY MARY JANE FAVORITE

The Right-hand Thumb Trick

I learned this in engineering school and soon found out it worked for my router. It is called the “right-hand thumb rule.”

When trying to remember which way your router bit is spinning so you can feed the wood in the correct direction, you can use the right-hand thumb rule.

Pretend your right hand is a router and your thumb is the router bit. If you are holding the machine with your hands and the bit is pointing down to the floor, then hold your hand in front of you with your thumb pointing to the floor. Then curl your fingers. That’s the direction your router bit is spinning.

If you are using a router table, hold your hand with your thumb pointing to the sky. Curl your fingers, and that’s the direction your router bit is spinning.

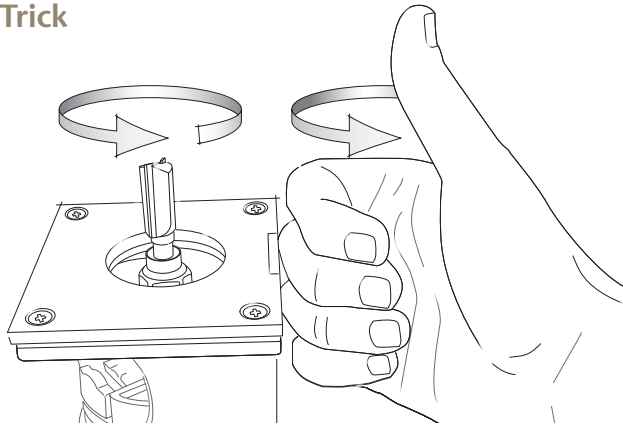

That way you will never get confused again and always know the correct feed direction.

And it works for almost anything that spins, such as faucets, regular-thread screws, changing a tire (if you want to know which way to tighten or loosen the nuts), etc.

Regis de Andrade
Tigard, Oregon

Band Saw Blades: Keeping Track

I know a few guys with more than one band saw in their shops, or band saws they use in a couple different configurations (i.e. with or without a riser block). So keeping blades sorted out for machines that require different blade lengths can be a pain. When looking through my pile of folded blades, I’ve become accustomed to using this easy method to find the right one.

1) Count the number of loops (usually three or five, never four – go ahead, try to fold a band saw blade an even number of times. I double-dog dare you);

2) Measure the diameter of the folded blade, I just ballpark it to the nearest half inch;

3) Multiply by three because it’s really close to pi (3.1416 ...)

This will give you the total length of the blade, or it will be close enough to differentiate between a 93" blade and a 111" blade (which is what I’m always looking for in my shop). This has also helped me when I’m buying blades – a couple of times, I’ve been sold the wrong length blade.

Frank Gibbons
Victoria, British Columbia

“Every great mistake has a halfway moment, a split second when it can be recalled and perhaps remedied.”

— Pearl S. Buck (1892-1973)
author, won Pulitzer and Nobel prizes

Avoid Splinters With Strategically Placed Tape

Whenever I do a lot of ripping on the table saw, jointing on the jointer or running moulding on the router table I used to get cuts and splinters in the finger that I used to guide the wood through the machine (my left index finger). This also could happen when I used my fingers as edge guides with my hand tools. Then I would go and get some tape and tape up the wound. Now I have learned to put masking tape on the finger before I do the operation. I then remove the tape when I am finished. I also don’t get blood on the wood this way. (I do not like to wear gloves while running equipment, I consider it unsafe.)

Michael E. Siemsen
Chisago City, Minnesota

Spark-plug Gauge is an All-purpose Screwdriver

Ever need to loosen the screw for your plane iron’s chipbreaker, but can’t find a screwdriver? Or worse yet, ever have your screwdriver slip and catch your hand on those “locked-up” screws?

A simple (and small) solution is to keep a couple of inexpensive spark plug gap gauges handy in your apron or on your bench. They are tiny, yet they will replace almost any flat-head screwdriver because of the graduated thickness of the rim of the gauge. They can even substitute as a feeler gauge in some instances. At only 99 cents each at most auto-supply stores, you can afford to keep a few on hand.

Benjamin Shaw
Long Beach, California

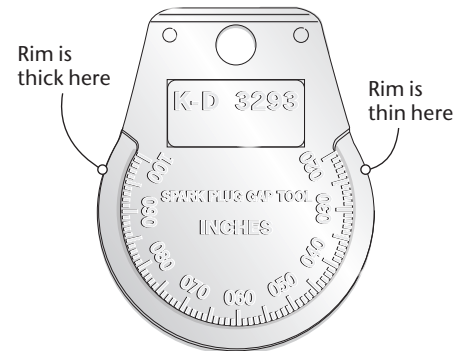

How to Add 200 Pounds (or so) To Your Workbench

We’ve all dealt with the problem of keeping our workbenches stationary and stable. We’ve ignored the most available solution – our body weight.

Turn your bench on its side and nail a scrap sheet of plywood to the bottom of the legs with the extra board out in front of the bench. Right the bench, stand on the plywood whilst planing or sawing and you will notice a marked increase in your bench’s stability. Have a big dinner for a really big increase!

If you know which part of the bench you use most, orient the plywood to stick out where you would stand on it for best results.

Walter Lees
Phoenix, Arizona

Use the Table Saw for Handplaning

My shop is too small for a large bench, and the 30" x 48" bench I have is usually at least halfway covered with planes, chisels, measuring tools and workpieces.

So I've made strips of wood of varying heights that fit perfectly into the miter slots on my cabinet table saw to act as "bench hooks" or "bench dogs." The varying heights work with different thicknesses, while the choice of miter slot works with different lengths. The table saw itself is perfectly flat. And because it

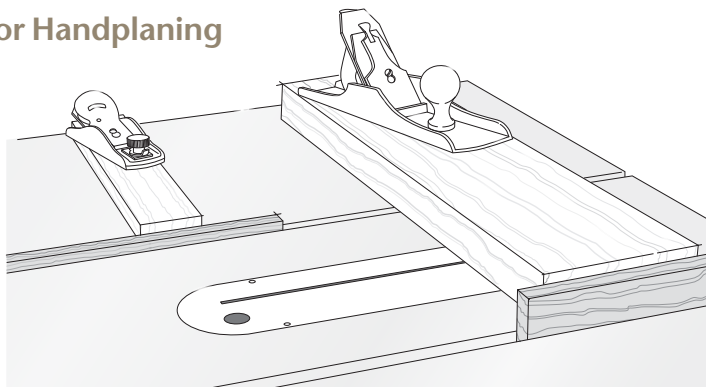

is (for me) the perfect height for handplaning, it works perfectly.

*Jack Camillo
Sykesville, Maryland*

Toothbrush Makes for Quick Corner Cleanups

When gluing up a carcass, some woodworkers clean up the glue when it's wet and some do it when it's semi-hard or dry. This is a trick for those of us who clean when the glue is wet. Use an old toothbrush to get into the tricky inside corners of a carcass. I perform this operation with a small bowl of water and a rag. I dip the toothbrush in the water, scrub away the offending glue and wipe the excess water away with a rag.

The scrubbing action of the toothbrush bristles ensures you won't leave any dried glue in the sharp corners, which would interfere with staining and finishing.

*Kelly Mehler
Berea, Kentucky*

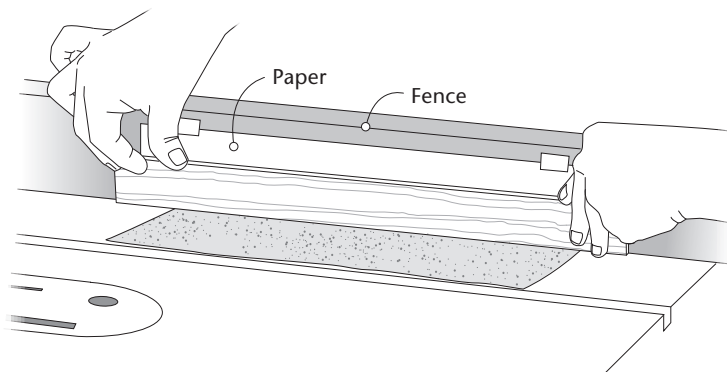

Perfectly Sanded Thin Edges

To sand thin edges perfectly square, slip a piece of sandpaper under the fence of your table saw then sand the edge while running the wood along the fence. Also, so that your wood doesn't get mucked up, affix a piece of paper to the fence.

*John Short
St. John's, Newfoundland*

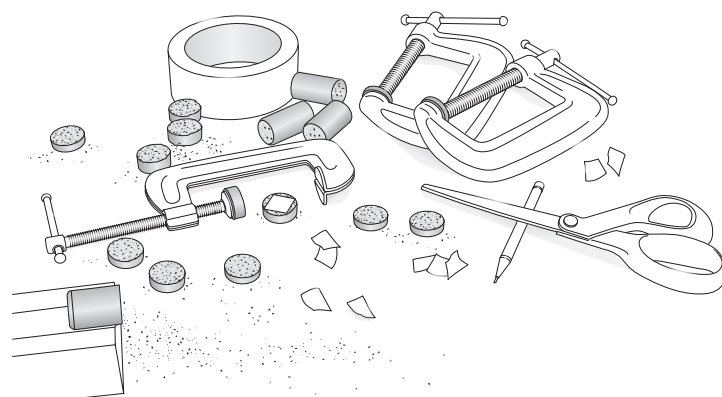

Bottoms-up for Better Clamping

I have saved a lot of time and aggravation by taking a handful of wine bottle corks, cutting them into 1/4"-thick disks and sticking them to the faces of my C-clamps with double-sided tape. This is a big time saver because I don't have to look for scraps of 1/4" stock, which is what I previously used to pad the faces of my clamps. Also, I save some aggravation by no longer having to hold the clamp, the project and two clamp pads while I tighten the clamp.

*David Leard
Mobile, Alabama*

More Tape Tricks: Use it to Make Accurate Crosscuts

If I'm cutting two boards to identical length, I tape them together first around all the edges to ensure they don't slide around. I also tape over the cutline, which minimizes splintering at the back of the cut (this is particularly helpful for cuts on a table saw). If I want to plane an edge, I plane them together. The broader edge is more stable, and there is less variation during the cut. Matching curves on a band saw? Good to go. Once the cut is made, the three taped sides hold everything stable while I sand or plane the curves fair. The tape can also help keep the wood from getting dinged up on the corners.

The nice thing about the tape is that it won't ever hurt your blades. After a cut, if the workpieces have any residue left on them, standard cleaner will take it off (it's much easier to deal with than pitch). The only problem I've ever had was if I left the tape on for a number of days on a softer- and shorter-grained wood, such as mahogany, which tends to lose a few fibers if you're not careful. But I'll trade that for mismatched cuts, different lengths or tear-out any day. **WM**

*Mark Rasmussen
Princeton, New Jersey*

SEND US YOUR SHORTCUT

We will provide a complimentary one-year subscription (or extend your current subscription) for each Shortcut we print. Send your Shortcut via e-mail to shortcuts@fwpubs.com, or by post to *Woodworking Magazine*, Shortcuts, 4700 E. Galbraith Road, Cincinnati, OH 45236. Please include your complete mailing address and daytime phone number. All Shortcuts become property of *Woodworking Magazine*.

Make Clean Through-mortises blog

Woodworkers expect this joint to be tidy and tight, not ragged and gappy. We explore the best ways to make this sometimes-vexing hole.

The history of the through-mortise begins with a joint that was necessary because of the tools and technology of the day, and it ends with a joint that flaunts the skills of the modern woodworker like a prize chicken at a county fair.

A through-mortise – which is where the joint passes entirely through a leg or stile – is rarely structurally necessary in modern furniture thanks to high-strength glues and machine-cut joinery surfaces that maximize the amount of wood-to-wood contact.

But they are sometimes necessary for other reasons: They are a hallmark of certain furniture styles, including some early American and European pieces, Arts & Crafts furniture and stick chairs, such as Windsors and Welsh chairs.

And in contemporary work, through-mortises are often used as the calling card for a handmade piece of furniture. Few furniture factories go to the trouble of making this joint, so individual makers use it to differentiate their work from the fiberboard garbage that clogs our stores, homes and landfills.

The reason the through-mortise is a poster child for handmade furniture is that it is a challenge to make well – much like the dovetail joint. People’s eyes are drawn to expressed joints like this, and small gaps make big impressions.

I’ve spent years investigating various techniques for making this joint tidy and show-worthy. The following story is the result of my trials and occasional revelations.

Real-world Through-mortises

Through-mortises appear in the earliest extant furniture. Egyptian beds and stools typically used the through-mortise to join their legs and rails. Exactly why this joint was employed isn’t



The torn grain, gaps and general loose fit around these through-mortises are unacceptable to the modern woodworker – though these defects were once common. This is an Arts & Crafts bookcase that once graced a church library in Lexington, Ky.

known, but we can guess. With a lack of reliable glues, a through-mortise joint allows lots of wood-to-wood contact – friction if you will – that will keep the joint together. Sometimes these joints were even lashed together, and the tenon passing through the mortise allowed this.

As furniture evolved through the 18th and 19th centuries, it became much more the norm to obscure joinery rather than show it off. Furniture craftsmen avoided the problem of unreliable glues by cutting a blind mortise (which is open only on one end) and then driving a peg through the finished mortise and tenon to mechanically lock the pieces.

“Only the mediocre are always at their best.”

— Jean Giraudoux (1882–1944)
French diplomat, dramatist and novelist

However, in the world of the workers who fitted out houses with doors and window sash, the through-mortise remained a staple of the trade. When joining the rails and stiles of windows and doors, through-mortises are typical even in houses built at the dawn of the 20th century.

The reason for that is two-fold. Doors and windows are made up of heavier pieces that need to take more abuse than a piece of fine furniture. Plus, a through-mortise has other advantages. It can be cut using fewer jobsite tools (a chisel and a mallet is all that is needed) and you don’t have to take the time to clean the bottom of the mortise. It can be assembled and wedged with fewer clamps – you can put one clamp on the joint, wedge it from the outside and immediately remove the clamp. And things can be more easily dismantled for repair – dig out the wedges and pull the joint apart.

And because the result was usually hidden by paint or by its location on the edges of doors or

in a window casing, the joint didn't have to look perfect. It just had to hold things together.

That's how things stood until the furniture factories came along. Some of the earliest factory machinery was designed to cut mortises and tenons. But in an effort to make less-expensive furniture for the masses, factories began using less-reliable joints – such as dowels – that could be made quickly and cheaply with precision machinery.

From the outside of the furniture, the results looked the same. A blind tenon and a doweled joint are indistinguishable from the exterior of a piece. And I've even seen doweled pieces that have a fake exterior peg, which implies there is a tenon in there instead of two skimpy bits of dowel.

Some furniture consumers were unhappy with this mass-produced flimsy furniture coming out of the factories. And from this discontent rose the Arts & Crafts movement. At its best, the Arts & Crafts movement celebrated stout joinery. High-quality pieces used through-mortises as a way to show the consumer how the joint was made. (Let's ignore, for a moment, the Arts & Crafts shysters that would nail on a fake through-tenon to fool the customer.)

These visible joints were put in visible places – on the tops of chair arms, on the fronts and ends of casework pieces, on legs. However, making these visible joints must have proved to be a challenge. They appear on only the best pieces. And they don't always look tidy (especially the ones that are close to the floor).

And then the through-mortise began to disappear again from furniture as the popular styles began to change to favor surface ornamentation to structural honesty.

Today the through-mortise joint is used when you are reproducing certain furniture styles or are attempting to display your craftsmanship. No matter why you make this joint, the standards for what is acceptable have changed. Gaps between a through-mortise and its tenon aren't acceptable in good work.

Two Kinds of Through-mortises

So the imperative is to make this joint look perfect, and the tolerances are tough to hit. Where do you begin? First, it's helpful to know there are two kinds of through-mortises, each of which requires a different strategy.

The first kind of through-mortise has an opening that is skinny and long – for example, 1/4" wide x 3" long. This is the kind of through-mortise you would see when you join a side rail on a Morris chair with the chair's front leg. It also is common to see this mortise where a shelf intersects the side of the carcass.

The other kind of through-mortise is simply larger – it can be either rectangular or square. This is the kind of through-mortise you would see when you join a chair leg to an arm.



This through-mortise on the lower leg of a Gustav Stickley rocker would not pass modern muster. The ends of the mortise were left round and the tenon was square. On other joints in this chair you can see tearing left from the boring machine.

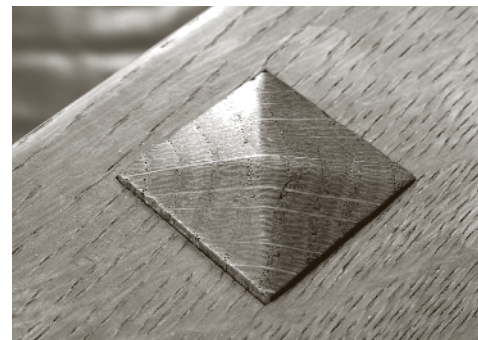

This through-tenon on an arm of a Charles Stickley side chair shows what good work looks like in a highly visible area. The joint isn't airtight, but it's quite good considering the 100 years that have passed since its making.



On the show side of a mortise, the edges must be crisp and not rounded over by the tool. Make lots of light cuts, then sweep the first bits of waste away using your chisel's edge flat on your work.

Let's walk through some of the techniques for cutting each of these.

Skinny and Long: Use Square Tooling

For any through-mortise, you can use a mortise chisel and a mallet. And if I have four or fewer to do, that is typically how I'll proceed. You lay out the mortise opening on both sides of the joint and then begin the banging. When I make my layout marks, I score them as deeply as possible on the face of the joint that will be visible. Deep score lines help you remove waste cleanly.

This is particularly important if the long axis of the mortise runs across the grain (like it does in the bookshelf in this issue). When you chisel out a mortise across the grain, it has a tendency to tear out around the joint, particularly in woods such as oak and ash.

Begin chopping out the side that will be obscured. Working from this side first allows you to get your chisel skills warmed up. If the chisel is cutting true, I'll drive down beyond the halfway point. Though removing waste is more

difficult in deep cavities, it's more important to get the two ends of the mortise to meet. So don't stop if things are going well.

Then flip the work and make a light cut on the face that will be visible. Some people will chop up the surface of the mortise with tight cuts then sweep the waste off the top of the mortise using the shaft of the chisel.

Once the initial opening is cut, you can drive more deeply. Just be certain not to lever the chisel against the ends of the mortise when prying out the waste. This pry-bar action rounds over the rim of the exit wound.

If you are not going to cut the through-mortise by hand, two other common options are to use a hollow-chisel mortiser or a plunge router with a straight bit and an edge guide.

I almost always choose the hollow-chisel mortiser. Here's why: The router method is slow. Through-mortises that are shaped this way (long and skinny) are typically in thick material – 3" thick is not uncommon. That can be a lot to ask of a 1/4"-diameter router bit. In fact, I've snapped

off quite a few in deep cuts. If you go the router route, take little bites. It slows you down, but it's easier on the tooling.

You also have to square up the ends of these router cuts (unless you want to make an authentic and gappy Gustav Stickley-style joint). This is a lot to ask of a hand-held chisel in thick material.

In router-cut mortises like this, the corners are tough to square up without botching them. You can score your layout lines with deep knife cuts, which helps. Ultimately, if you take this path you are going to have to get good with a chisel.



Press and hold a ruler to a flat face of your hollow chisel. Compare the ruler to your layout lines to see if the chisel is twisted. This trick is remarkably accurate.

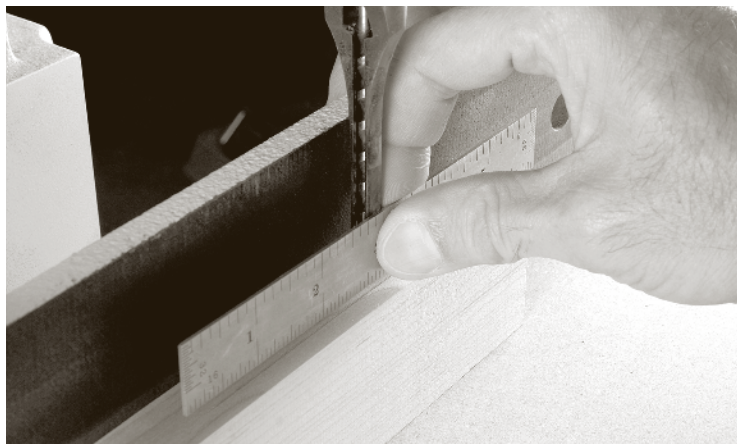

I'm in the habit of using the leap-frog method of mortising. Skip a space with every hole, then clean up between the holes. Other craftsmen I respect say the holes should overlap slightly to improve chisel cutting. Try both and decide.

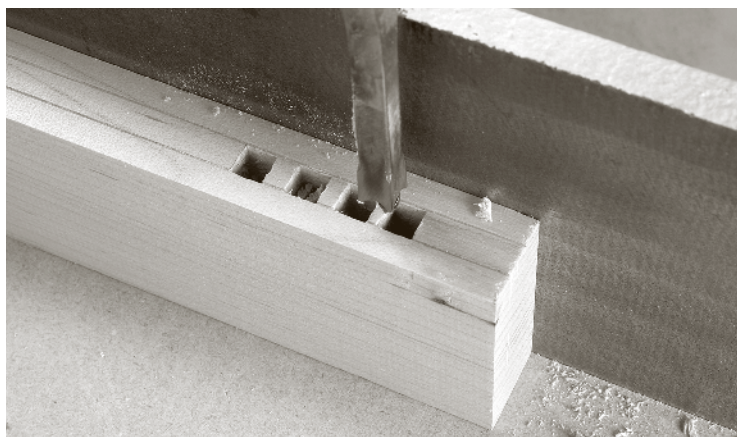

You have to take care and take smaller bites so your tool doesn't go astray.

The hollow-chisel mortiser is fast and can make a clean cut if you set up the machine with care. Let's begin there. You need sharp tooling. File the cutter of the auger-bit part of the tooling and stone the inside and outside of the hollow

chisel. For complete details on choosing the right bit and sharpening it, read our story on hollow-chisel tooling in the Spring 2007 issue.

You need to have your hollow chisel set dead parallel to the machine's fence. You can get there by trial-and-error. But here's how to make it there with less error. Lay out a sample mortise on some test scrap. Bring the hollow chisel close to your layout lines. Now press a 6"-long ruler against the hollow chisel and compare it to your layout line. The ruler will exaggerate any twist in the chisel and allow you to fine-tune it in the bushing of your hollow-chisel mortiser.

Now make a sample mortise to confirm that you are cutting where you want to cut and that the chisel is parallel to the fence. Now get ready to prepare your live stock. Normally, most instructions assume that your project parts are square. When making through-mortises, your parts have to be as square as possible. Double-check each part after you square it up and before you make your mortises. Small errors make joints that won't go together. I've found that it pays to have the part's jointed face against the mortiser's fence.

To bore the mortise, first work halfway through on one side. Then flip the work over and do the same thing on the other. If the machine is set up well, this work is extremely fast and clean.



Here you can see the result of accurate machine setup and careful layout. The mortise goes clear through, and the rim of the mortise is crisp enough for close inspection.

Bigger Joints Require Different Tools

The rules change when the through-mortises get bigger. Once your joints are wider than $\frac{1}{2}$ ", then hollow-chisel mortisers become difficult to use. When your mortises are wider than $\frac{1}{2}$ ", you have to shift your work both left-to-right and back-to-front to clean out the mortise. That's not always a simple thing to do with accuracy. And you really need an X-and-Y sliding table. (Side note: I'm aware there are bigger bits available for hollow-chisel mortisers, but they don't work on the common benchtop machines.)

Here's the other thing that changes: Usually with larger through-mortises, you are working on thinner stock, typically $\frac{3}{4}$ "- to $\frac{7}{8}$ "-thick stuff.

So a new strategy is in order: router templates. Because your stock is thinner, the 1"-long straight bits have no problem cutting these joints with ease. Plus, as you'll soon see, the routing template can also be a chiseling template for squaring up the corners.

You can make these router templates to use either a pattern-guided straight bit or a bushing installed in your router's baseplate. The templates

for pattern-guided bits are simpler to make (no math), but it's tricky to get your bit's bearing and the thickness of your pattern all playing nice together.

On the other hand, the templates for bushing-guided bits require a little math (addition – plus its tricky friend, subtraction). But you're fooling around a lot less trying to match your bit and the thickness of the material out of which you are making your pattern. So really it's a wash as to which method is faster.

No matter which path you choose, you need to make a pattern out of plywood (or solid wood) that has an opening with perfectly sharp corners. Making that pattern is fairly simple: I saw up bits of plywood (typically $\frac{1}{2}$ " in thickness) and reassemble them as a panel that has the right-sized hole for my routing pattern.

Remove as much of the waste as you can with a Forstner bit, then clamp the router template in place. Be sure to secure the template to the outside face of your work. Rout out the rest of the waste but don't remove the template because its job isn't over. You can use its sharp corners to guide your chisel to square up the rounded corners.

This technique yields nice crisp corners on the outside of your work and ragged, torn-out corners on the inside surface (because there was no template to guide your chisel). This isn't a problem as long as the tearing isn't too severe.

Once you get the mortise cut, the tenons are easy. I cut them close on my power equipment, then trim them to a snug fit with a shoulder plane, which also removes the marks left by the power tooling. **WM**

— Christopher Schwarz

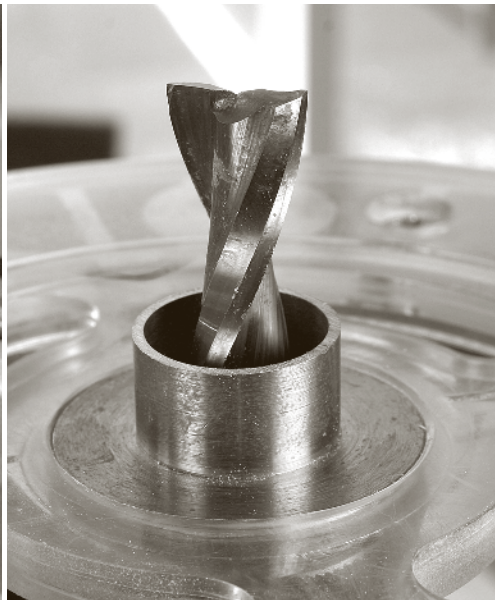

The pattern-cutting bit (left) seems simpler (just make a pattern that is the correct size), but you have to set things so the bearing rides the pattern and there is enough cutter showing to do the job. Bushing-guided patterns simply require a slightly oversized pattern.

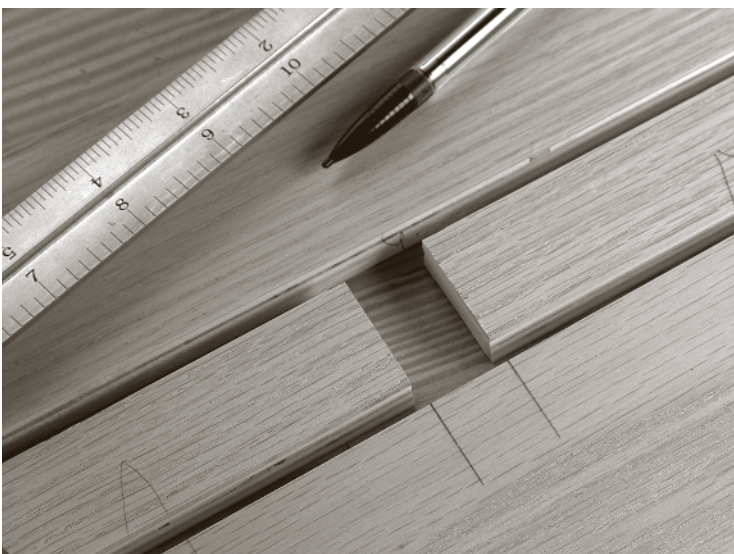

Here you can see how a pattern was assembled for a through-mortise. I use only glue on the edges to join the parts – no biscuits or dowels. With plywood, there's always enough long grain at the edges to make this panel plenty strong.



Take little bites with the chisel. If you try to remove the entire corner in one whack, bad things can happen. The template can shift. Or the chisel will steer itself outside the template – but below the surface of your work.

Gustav Stickley Plant Stand

Does good work have to be flashy? Building a piece that focuses on existing skills can please both you and other woodworkers.

The clock read 3 a.m., but my body was still on East Coast time, so I was wide awake and shuffling around Gary Rogowski's house in Portland, Ore., like an unshaven ghost.

Rogowski is a long-time furniture maker and the owner of the Northwest Woodworking Studio school. And like most woodworkers, his house is filled with his own work. As I fumbled in the dark looking for the stairs, my hands came to rest on a dresser in the hallway.

The oak piece had simple Arts & Crafts lines and pleasing proportions, but it was not the sort of object that shouts for attention from the other side of a room. With time to kill and a curiosity about his work, I scrutinized the dresser the way only a woodworker can.

I pulled out each drawer. I poked around the interior of the carcass. I looked for filler in the dovetails. I examined the surfaces for defects in planing, sanding or finishing. It takes a lot to impress me before my first cup of coffee, but Rogowski's piece did just that.

Though simple in form, the piece was perfect in execution. For me, that dresser served as a reminder of something that I tend to lose sight of as I strive to become a better woodworker. Simply put: Refining your existing skills is as important as acquiring new ones.

So when I returned to Cincinnati, I vowed to build a piece that used basic joints, but that would require complete mastery of them to produce a finished project that could withstand the scrutiny of a fellow woodworker poking around my house in the wee hours.

The Gustav Stickley Plant Stand

For many years I've wanted to build a replica of this Gustav Stickley plant stand. The form doesn't



The goal was to get the details right. Though simple in form, this piece is a challenge to do well. Building it will improve your ability to execute precision joinery and crisp corners.

show up in the catalogs I have for Stickley's furniture company, but I have stumbled upon signed examples at auctions and have seen them in a number of books.

Composed of only 16 significant sticks of wood, this plant stand is not flashy like a Morris chair or sideboard. But it is a well-proportioned and thoughtfully engineered piece of furniture.

PHOTO BY AL PARRISH

All of the joinery has to be spot-on for the piece to work.

The version shown here had to be redesigned a tad for a practical reason. The green tile top in the original was an odd size (10" x 10") that you are unlikely to find at a store. So if I'd slavishly followed Stickley, you would be stuck cutting down a larger tile or commissioning a ceramic artist to make you one.

With a little work on the computer, I resized the project to accept a common floor tile from a home center (price \$1.46) and it changed the overall dimensions of the piece by only 1".

So the first step in building this plant stand is to shop for a tile. The so-called 12" x 12" floor tiles at the home center were slightly smaller than 11³/₄" x 11³/₄". So I scaled all my parts around those dimensions. My tile doesn't match the beguiling green of the Grueby-made tile in the original, but I came close. As you shop for tile, check out the natural slate tiles, which vary in color. I found a few slate tiles that were a better historical match. When I returned to the bin the next day to buy them, they were gone.

Perfection Begins With Selection

When you build a simple and small piece of furniture, the importance of wood selection is magnified. Every stick carries more visual weight. Plus, this project doesn't have a front or back. It has to look good from all angles.

The trickiest part of stock selection is in the legs. Making legs with quartersawn white oak is a challenge because each board has two faces that exhibit quartersawn grain and two faces that exhibit flat-sawn grain. And they look so radically different that it is distracting.

To duck this problem, you can veneer quarter-sawn oak on the flat-sawn faces (a trick employed by Gustav Stickley on some pieces). You can

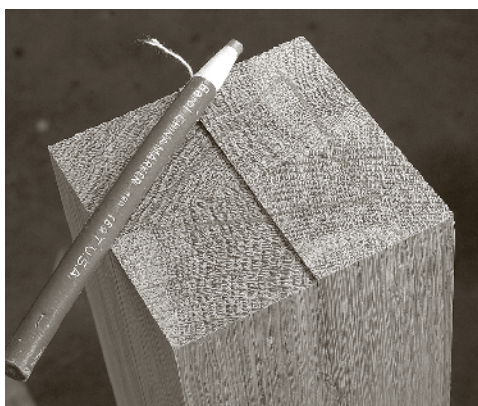

Here are my four legs for the plant stand. Except for the leg at top right, they are rift-sawn. I got lucky with the leg at top right. Even though it is quartersawn on two faces and flat-sawn on the other two, its grain pattern is consistent all around. Trees are weird that way sometimes.

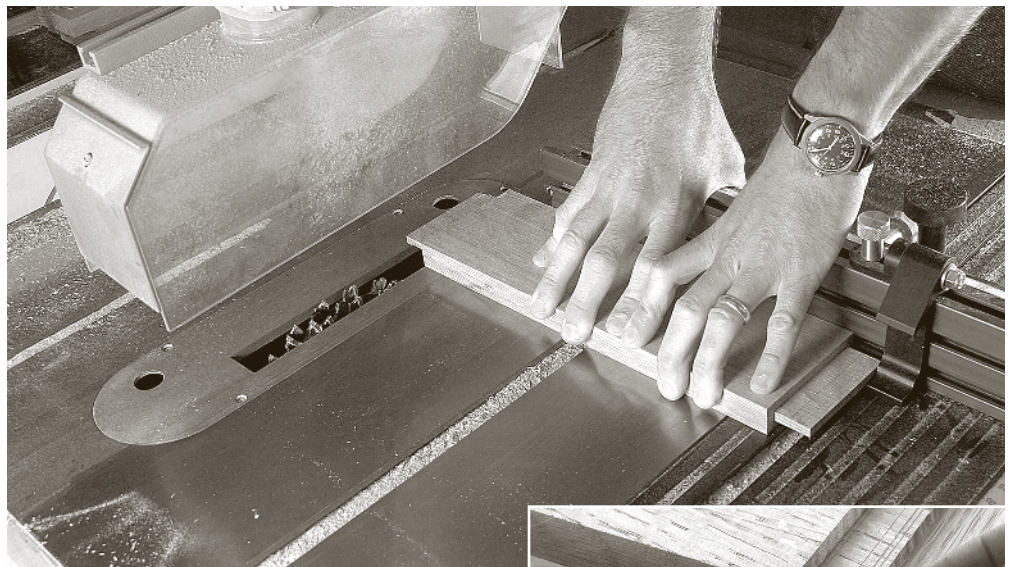

With 22 tenons to cut, I opted to make these joints with a dado stack in a table saw. A fence with a stop ensures the accuracy you need for this operation. The tenons' face shoulders and edge shoulders are both 1/4" so you can make all these joints with the dado stack protruding 1/4" above the table.

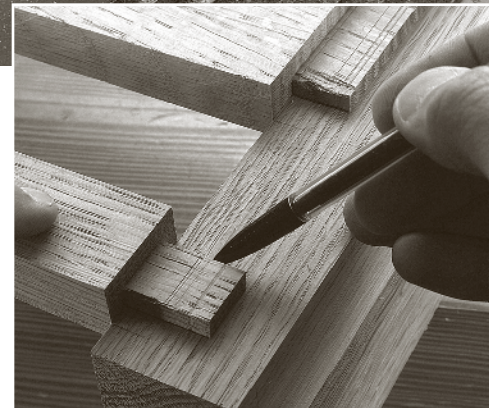

make each leg out of four pieces of quartersawn material mitered at the corners (a trick employed by Gustav's brothers Leopold and John). Or you can do what I did: Don't use quartersawn oak for the legs.

I used rift-sawn (sometimes called bastard-sawn) white oak for my legs. Technically, a board has been rift-sawn when its annular rings intersect the face of the board at an angle that's somewhere between 30° and 60°. With quartersawn boards the angle is higher than 60°. With plainsawn boards, that angle is lower than 30°.

The beauty of rift-sawn boards is that their faces and edges look similar, especially if you select boards that have the annular rings at 45° to the face. As a result, a rift-sawn leg will usually look the same no matter where you are in the room.

A Tangle of Tenons

Another challenge with this project is making all the mortise-and-tenon joints come together. While all the stretchers and aprons join their legs with a simple mortise-and-tenon joint, the first complication is that the tenons intersect one another at the corners inside the legs. Plus, the four wide aprons aren't centered on the legs. Instead, they're pushed to the inside a bit to nestle closer to the tile top.

As a result, the tenons on the top stretchers are 1" long and are mitered to meet at the corners. The stretchers on the aprons can only be 3/4" long and these are also mitered to meet at the corners. This means you have to lay out the locations of

I mark out the location of my mortises by using my tenons like a ruler. Note that you can see here how the top stretcher has a longer tenon than the apron does.

your tenon shoulders with great care. All the stretchers and aprons need to measure exactly 11³/₄" from shoulder to shoulder. And then you add a third tricky part to the project's joinery: A through-tenon that pierces the lower stretcher and is secured with a tusk.

We'll tend to that through-tenon later. First cut the 1/4"-thick tenons on all the aprons and stretchers – by hand or by power – then prepare to use those tenons to lay out the locations of your mortises in the legs.

With the tenons cut, you can use those joints to lay out the location of mortises on your legs as shown in the photo above. This method requires less measuring and therefore offers less opportunity for error.

Mismatched Mortises

The mortises for the top stretchers and the lower stretchers are centered on the legs. So set up your hollow-chisel mortiser (or your mortising gauge) to poke a 1/4"-wide x 1/8"-deep mortise in the legs. Then make all those mortises.

Note that getting mortises that are dead-center on a leg is a challenge for many machines and

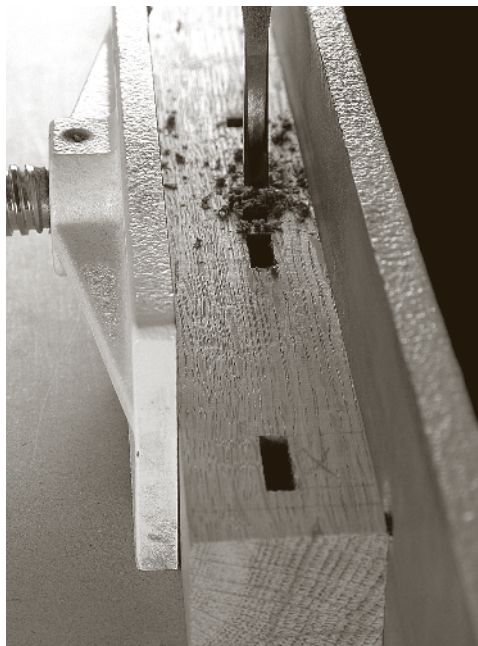

Here I'm making the mortises for the aprons, which are located $\frac{1}{2}$ " in from the inside edge of each leg. Each of the apron mortises measures $\frac{1}{4}$ " wide, $3\frac{3}{4}$ " long and $\frac{7}{8}$ " deep.

their operators. To side-step the problem, get the machine set as best you can. As you work, ensure that you always work with an inside face of the leg against the mortiser's fence. This ensures that even though the mortise might not be centered, all the mortises will match up on all four legs.

Then you'll need to adjust your machine (or layout tools) to cut the mortises for the four aprons. These aprons are set $\frac{1}{4}$ " in from the inside corner of each leg, so the mortises for the aprons should be located $\frac{1}{2}$ " in from each inside corner. These mortises don't need to be as deep either— $\frac{7}{8}$ " deep will be enough to house the tenon and allow for a little gunk and glue at the bottom.

The mortises for the top stretchers and aprons intersect, which means you'll likely get some splintering on the inside corner where they meet. There's little you can do to prevent it (mortising is quite violent). If it's a minor split, you can pull the splinter out and ignore it. With oak, sometimes it splits badly and I'll glue the splinter back in and secure it with tape as the glue dries.

More Mortises Yet

The lower stretchers each get a highly visible through-mortise, which will house the through-tenons and tusks. I've experimented a lot with different methods to get clean through-mortises (see "Make Clean Through-mortises" on page 6 of this issue). For mortises that are nearly square, the best technique I have found is to first make a plywood pattern and rout them out. Then you come back and use the same pattern to chisel the corners square.

Gustav Stickley Plant Stand

NO.	PART	SIZES (INCHES)			MATERIAL	NOTES
		T	W	L		
□ 4	Legs	$1\frac{5}{8}$	$1\frac{5}{8}$	26	Oak	
□ 4	Top stretchers	$\frac{3}{4}$	$1\frac{1}{4}$	$13\frac{3}{4}$	Oak	1" TBE
□ 4	Aprons	$\frac{3}{4}$	$4\frac{1}{4}$	$13\frac{1}{4}$	Oak	$\frac{3}{4}$ " TBE
□ 2	Lower stretchers	$\frac{3}{4}$	$3\frac{1}{2}$	$13\frac{3}{4}$	Oak	1" TBE
□ 1	Cross stretcher	$1\frac{1}{4}$	$1\frac{5}{8}$	$17\frac{1}{8}$	Oak	
□ 2	Tusks	$\frac{5}{8}$	$\frac{7}{8}$	$2\frac{1}{2}$	Oak	Start with 7" long
□ 4	Top strips	$\frac{1}{4}$	$\frac{3}{4}$	$11\frac{3}{4}$	Oak	
□ 1	Panel	$\frac{3}{4}$	$12\frac{1}{4}$	$12\frac{1}{4}$	Oak	Notched at corners
□ 2	Bottom cleats	$\frac{3}{4}$	$\frac{3}{4}$	$11\frac{3}{4}$	Oak	

TBE = Tenon both ends

Yes, it seems like a lot of trouble. But this is a visible joint and worth the effort. I make my plywood patterns by sawing up scraps of plywood and assembling them into a panel that has a hole shaped like the mortise I want.

With your pattern assembled, use it to lay out the location of the $\frac{3}{4}$ " x $1\frac{1}{8}$ " mortise and trace its shape onto the lower stretcher. Waste away as much of the mortise as you can using a Forstner bit (Forstner bits allow you to overlap your holes).

Then clamp the plywood pattern to your workpiece and install a pattern-cutting bit into your router. Cut around the mortise (go clockwise) until you have wasted away everything the pattern-cutting bit can get. Don't remove the pattern from your work.



Here are the four pieces of $\frac{1}{2}$ "-thick plywood that I have sawn up and will glue back together into a panel. Note that I don't use biscuits or dowels to join these pieces, just glue. The edge grain of the plywood is strong enough for this light-duty application.

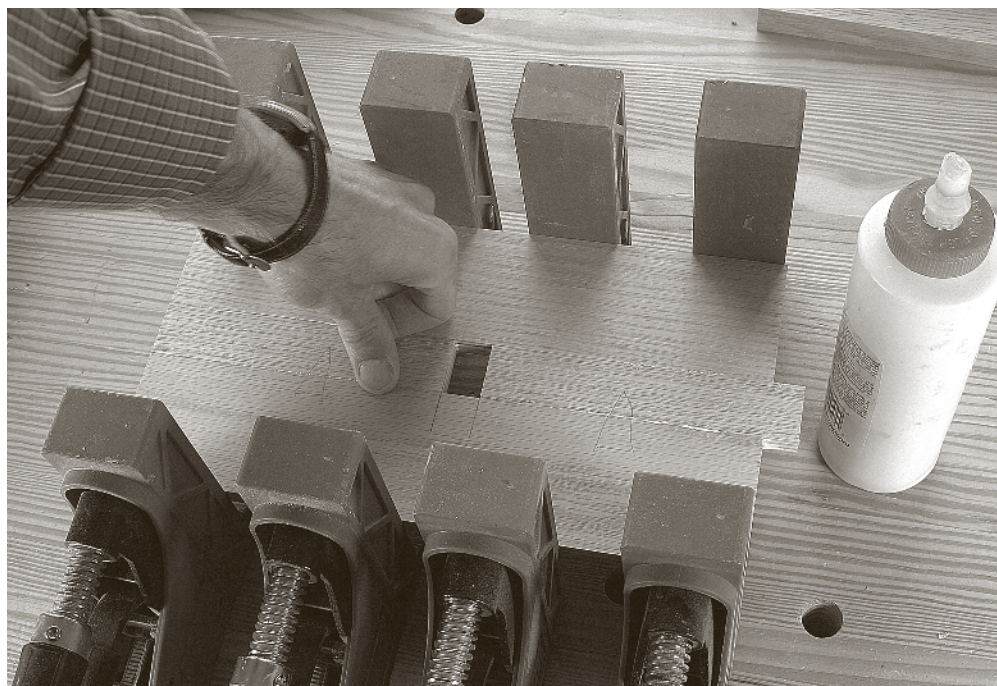

When you glue up the pattern, wrangle the pieces as best you can so that they line up at the seams. Mismatched seams will end up as bumps that your router will have to travel over—spoiling your accuracy.

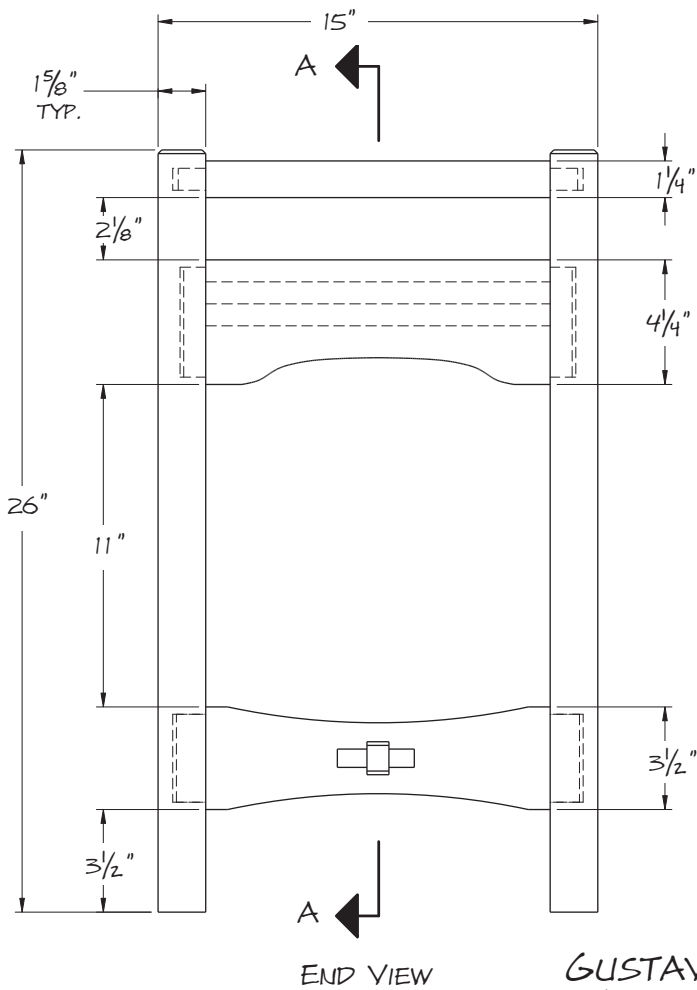
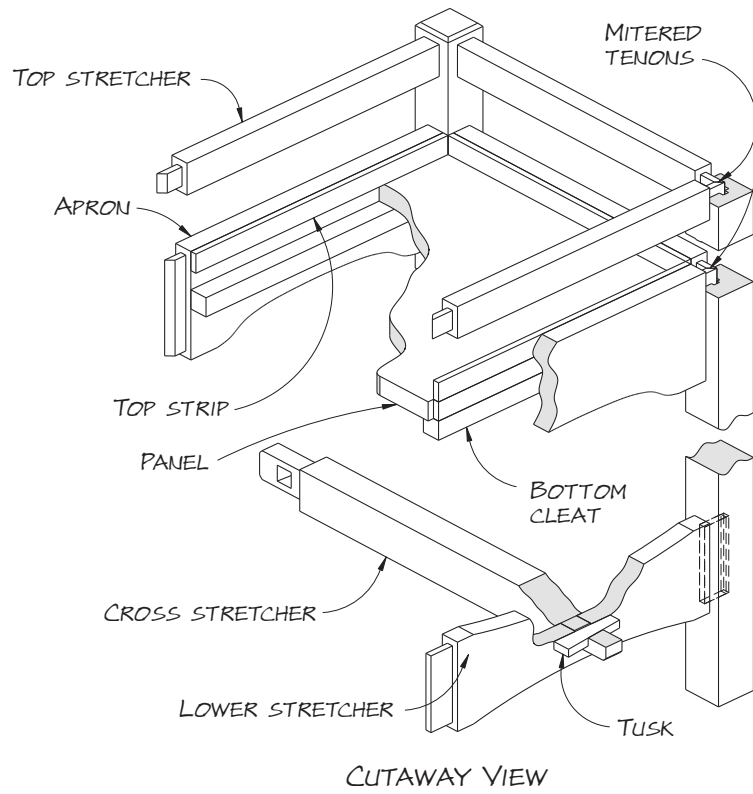
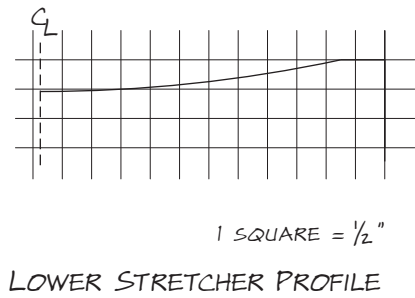
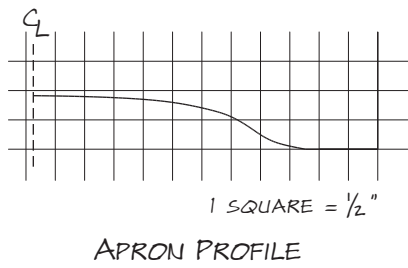

GUSTAY STICKLEY
PLANT STAND

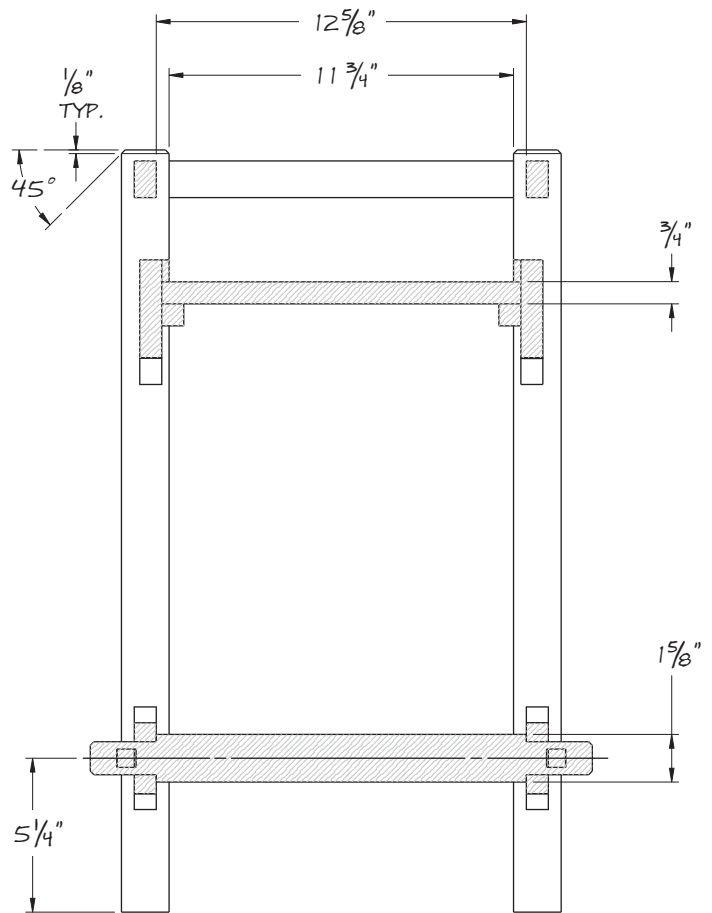

ILLUSTRATIONS BY LOUIS BOIS



I used a $\frac{5}{8}$ " Forstner bit to waste away most of the mortise in the lower stretchers. You could use a smaller bit and a handheld drill as well. That just makes more work for the router.



Clamp the pattern on your work and cantilever things off your bench (you don't want to mortise your benchtop). Then use the pattern-cutting bit to hog out the waste that the Forstner bit couldn't get.



Use the plywood pattern as a chiseling guide to clean out the corners. Shown is a $\frac{3}{8}$ " corner chisel, though a garden-variety bench chisel will work just as well. It will just take twice the number of whacks.

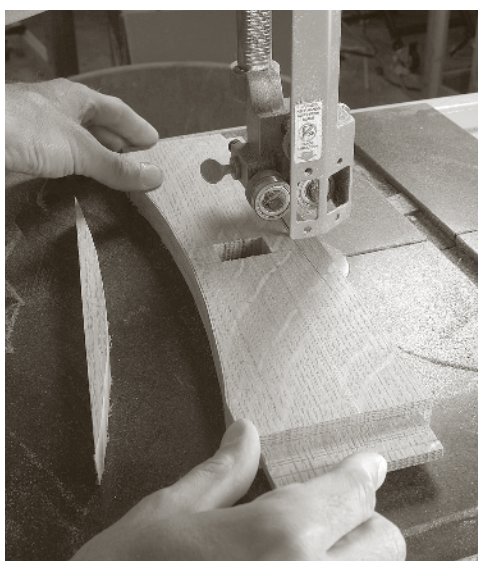

When you band saw a curve, the temptation is to leave a lot of waste behind so you don't accidentally cross the line. I try to saw right next to the line. I get smoother curves and have less waste to remove with a rasp or router in the end.



I actually do the bulk of my routing with a laminate trimmer. This small tool has more than enough power for most work-a-day tasks, plus the smaller footprint makes clamping setups such as this a breeze. A full-size router would run into my bench's hold-downs.

Fetch a chisel or a corner-cutting chisel, and use the pattern to cut away the rounded corners left behind by the router bit. Don't try to remove all the waste in one whack. If you do, your chisel will try to push the pattern out of place. Take two or three small bites instead of one big one.

Precision Curves

An Arts & Crafts piece with eight curved edges is a bit unusual, but it is these curves that really set apart this design from similar plant-stand designs that competitors built and sold during this era. The curves on the lower stretcher are simply a segment of a 24"-radius circle. The ogee-shaped edge on the aprons is a somewhat more complex piece of work.

When confronted with a curve or two, I'll band saw out the bulk of the waste and shape the curve with a rasp. But because each of these patterns is repeated four times on the piece, I thought it best to produce a plywood routing pattern then clean up the edges by hand.

I made one plywood pattern for both shapes: One edge had the simple curve; the other edge had the ogee shape. I scribed the 24"-radius curve with a set of trammel points. To make the ogee edge, I first scaled up photographs of original plant stands to full size and created the pattern from those – I wanted this unusual curve to be just right. You can use the scale drawings to make your plywood patterns. Then I used these patterns to lay out the curves on the aprons and lower stretchers.

Saw out the bulk of the waste, then use your plywood pattern to clean up the edge with the help of a router and a pattern-cutting router bit. Then clean up your edges with a scraper and sandpaper – the surface left behind by a router bit isn't good enough to finish.



After routing, I scuff each edge with #120-grit sandpaper. This makes it easy to see my progress with a card scraper. When all the fuzzy grain from the sandpaper is gone, the edge is clean and ready to finish.



When you miter the ends of tenons, it's unlikely you'll get them to mate at the center of the joint. That would be asking a lot (but if it happens, great). Instead, miter them so that they barely miss one another. That ensures your tenons will seat completely in their mortises.

Cleanup and Test Assembly

At long last it was time to break out the handplanes – the fun part. After cleaning up all the flat surfaces with a jointer plane and a smoothing plane,



With the plant stand clamped up, mark on the top edge of the lower stretchers where the cross stretcher will be located. Then lay the cross stretcher on those marks. Use a ruler to then measure the distance between the two lower stretchers.

I hand-fit all the joints then mitered the corners of the aprons and top stretchers.

Now you can assemble the project without glue to determine the size of the cross stretcher that is wedged between the two lower stretchers. Clamp up the entire plant stand and determine the exact distance between the two lower stretchers – that will be the distance between the shoulders of your cross stretcher.

Now you can mark out the $\frac{3}{4}$ " x $1\frac{1}{8}$ " tenons on the ends of the cross stretcher. The tenons should

be $2\frac{1}{4}$ " long, but you should confirm this with your dry-assembled piece. Now consider how you will cut these tenons. Using a dado stack will leave a surface that will require a lot of cleanup. I think you'll get cleaner results using a router or cutting them by hand.

That Touchy Tusk

If your tusks are designed properly, then installing them in the tenons is a simple operation. Most tusk troubles occur when the tenon is too short to

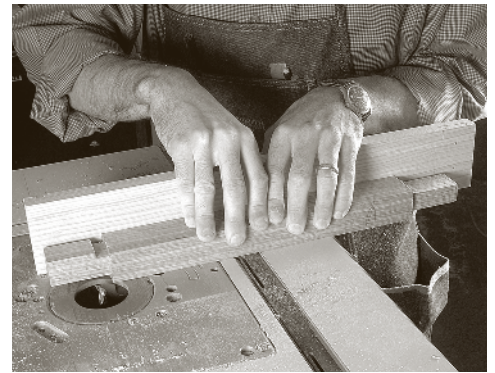

If you cut the tenons on your cross stretcher with a router, you'll need to set up a fence with a stop. Honestly, I did this setup to see how much of a pain it was. By the time I started adding the fence to the miter gauge, I would have been done if I'd just cut these by hand.



The hole for the tusk is offset a bit so that part of the mortise will be inside the lower stretcher. This is a critical point for a snug-fitting tusk.

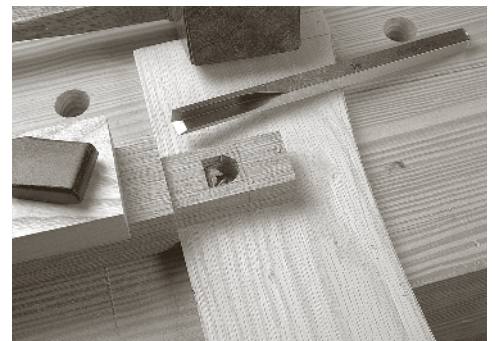

Take small bites when cleaning out the rounded corners of the mortise for your tusk. Begin with the corners that will be buried in the lower stretcher – if you botch these they will never show.

handle the tusk. Then it's tap, tap, crack – and the end of your tenon pops off. That's why the tenons are so long on this project's cross stretcher.

The first step is to bore a $\frac{5}{8}$ "-diameter hole through the through-tenon. The location of this hole is critical. Knock together the cross stretcher

and lower stretchers then trace a line around the through-tenon where it emerges from the lower stretcher.

Now lay out the location of the $\frac{5}{8}$ " hole so $\frac{1}{16}$ " of it crosses over this line. This space ensures the joint will tighten up when the tusk is knocked home. Drill the hole and square out the corners with a chisel.



Use a sliding bevel gauge set 4° off vertical to help guide your eye as you chisel out the mortise. The goal is to remove a wedge of material that is $\frac{1}{16}$ " thick at the top that tapers to nothing at the bottom of the mortise.

One face of this through-mortise needs to be angled to match the angle on the tusk. I've found a 4° angle to work nicely. To lay out a 4° angle on your mortise, simply scribe a parallel line that is $\frac{1}{16}$ " away from the edge of the mortise. That will give you the 4°. Then use a bench chisel to chop an angled ramp on this one face of the through-mortise. All the other faces of this mortise are left perpendicular.

Most people struggle with making the tusks. Here's the easy way: Start with a piece of oak that is $\frac{5}{8}$ " x $\frac{7}{8}$ " x 7" and cut a 4° taper on the width of the piece. Drive this overlong piece into the through-tenon until everything fits snugly and the tusk is roughly centered on the mortise. Then mark the final length of the tusk and cut it to size with a handsaw.

One Last Detail

One of the hallmarks of Arts & Crafts furniture is a small chamfer on the ends of legs, tenons and posts. I've always judged other people's work by these chamfers because they can be done quite poorly (got a belt sander?). Even when it looks like the maker wanted to take extra care, the grain can be easily torn out or splintered at the corners.

Once again, this is an area where I've experimented a lot with both hand and power techniques. And though I'll never give up my chamfer plane for long-grain chamfers, making them on end grain is a task best handled by a disc sander. (See the story "Improving Small Chamfers" on page 18 in this issue for more information.)

Assemble in the Right Order

I like to break all the long edges of my work right before assembly. It's easier to reach all the long

edges with the sandpaper, and it prevents you from having sharp edges in tight corners where your sandpaper wouldn't go. Plus, it's just as fast as doing it after assembly.

Glue up the two ends of the plant stand that have lower stretchers. Paint the inside of the mortises with glue and clamp things so the open mortises face the ceiling to prevent excess glue from running everywhere.

Once the glue is dry in the end assemblies, paint glue on all the blind mortises, slip the cross stretcher in place and clamp up the remaining top stretchers and aprons. Now you can turn your attention to getting the tile in its proper place.

"The perfection of a clock is not to go fast, but to be accurate."

— Luc de Clapiers, marquis de Vauvenargues (1715 - 1747), moralist and essayist

A Raised-panel Tile?

The tile rests on a panel of secondary wood that is sandwiched between strips of wood that are fastened to the inside of the aprons. The strips of wood create a groove that the panel floats in.

Four of these strips are visible. These $\frac{1}{4}$ " x $\frac{3}{4}$ " x $11\frac{3}{4}$ " strips rim the top of the aprons and fill in the space between the legs and aprons. Fit these strips between the legs and secure them with glue, pins and clamps.

When the glue dries, flip the plant stand on its head and fit the panel in place. You'll need to notch out its corners and allow a little expansion gap (unless you use plywood for this piece), but



Plane down the over-long tusk until it fits snug in the through-mortise. The advantage to using a plane is that you remove a predictable amount of material with each pass – and the tusk is ready for finishing when you are done.



I wouldn't dream of cutting the tusk to length with power equipment. It's too dangerous. A backsaw and a bench hook make short work of the task.

that is easily handled by a backsaw and block plane. When the panel fits, secure it against the top strips and nail in two $\frac{3}{4}$ " x $\frac{3}{4}$ " x $11\frac{3}{4}$ " cleats below. The cleats should properly cross the width of the panel.

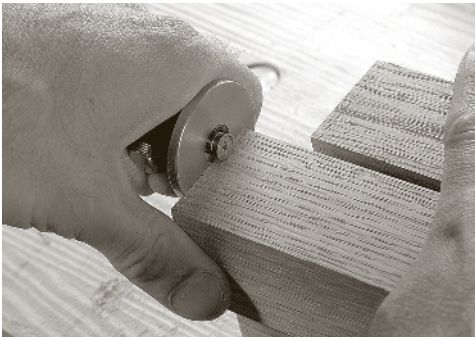

Lay out your chamfers by lightly scoring the ends of your legs using a cutting gauge set to $\frac{1}{8}$ ". Don't make this mark too deep or it could be visible on your completed work.



Set a miter gauge to 45° and use that to guide the leg gently to the spinning disc of the disc sander. (I have one of these sanding discs as an accessory for my table saw. It works great.) When your chamfer reaches your scribed line, back the leg away from the disc.

For the finish, I used the formula developed for the Spring 2007 issue ("Authentic Arts & Crafts Finish"). The recipe is as follows: Stain the bare wood with Olympic Interior "Special Walnut" oil-based stain. Let the wood soak for 15 minutes under the stain then wipe off the excess.

The next day, apply Watco's "Dark Walnut" Danish oil with a rag. Let it soak for 15 minutes then wipe off the excess. On the third day, apply one coat of Zinsser's Bulls Eye amber shellac. Shellac gets quite glossy, so you can add a coat of paste wax to reduce the sheen. Or you can apply a satin wiping varnish, which will give you extra protection (this project will see some water) and also reduce the sheen.

Attaching the tile is the easy part. I used a bead of tile adhesive. Draw the adhesive onto the wooden panel then press the tile into place. Take care not to use too much adhesive because it can easily squirt out from below the tile and make a mess of things on your finished project. Allow it to sit overnight. If you expect the plant stand to see lots of overflow, consider grouting around the edge of the tile as well.

This project will not end up in my home (we seem to kill all forms of foliage), but it will have my name on it. So if there are ever jetlagged woodworkers poring over this project, they'll know who got the details of this piece just right. **WM**

— Christopher Schwarz



After you clamp up the ends of the plant stand, inspect the open mortises. It's possible that excess glue ran all over the open mortise. If it dries there, it could interfere with your final assembly. Tease it out (I use a coffee stirring stick).



Take care when installing the strips at the top of the aprons. You want the strips and the apron flush, and you don't want unnecessary glue squeeze-out. Cleaning up this seam is tough thanks to the top stretcher.



Nail, but don't glue, the cleats in below the panel. If the tile ever breaks it will be easier to repair if you can pry off the cleats, remove the panel and replace the tile.

Improving Small Chamfers

While the definition for this edge treatment is short and simple, the methods used to create end-grain chamfers are many and varied.

Sharp corners and edges on a project present a problem. A sharp edge is less likely to hold stain, it can catch your clothing as you walk by and it will undoubtedly be the first area that shows wear. This is why you should always “break” the edges of your work before moving on to the finishing stages.

Break the edges with sandpaper and you simply create a minute roundover profile. However, a more prominent edge treatment, and the method used on the tops of the legs on the “Gustav Stickley Plant Stand” (see page 10 in this issue), is a small chamfer.

A chamfer is a flat surface that connects two faces. Chamfers are generally cut at a 45° angle to those faces, but not always.

How a woodworker creates a chamfer is often a reflection of his or her style of woodworking. If you’re a hand-tool aficionado, you’re less likely to turn to a router or router table to cut a chamfer. On the other hand, if you are a power-tool builder, I doubt you would grab a chisel to do the work. While a chisel and a router are both valid methods for creating chamfers, rasps or a disc sander are also popular choices.

Hand-tool Chamfers

Small chamfers can be cut by hand with a few different tools. If you’re a hand-tool devotee, you might immediately think handplane. But for an end-grain chamfer this small, I would pass on attempting it with a plane. There just isn’t enough surface area on which the plane’s sole can ride and accurately cut.

If you have a well-developed eye and can follow lines on your project, a chisel might be your best solution for small chamfers. Some hand-tool woodworkers turn to a rasp (another option that

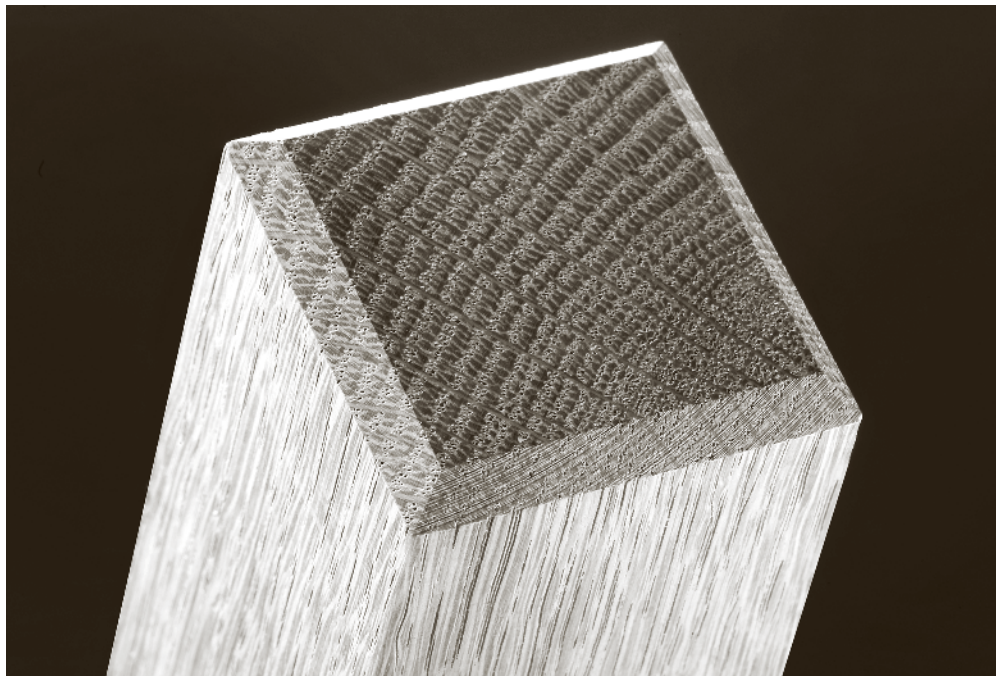

PHOTO BY AL PARRISH

Ideal small chamfers have a consistent profile on all edges – the corners align and the slopes match – and the appearance is “crisp.” Discover a better technique to create this simple, classic edge treatment.

requires a keen eye). Both of these methods have advantages and disadvantages.

Each method begins with marking layout lines for the chamfered area. The tool of choice is a marking gauge. Set the gauge to the appropriate size, then mark the surfaces to define the chamfers. In the plant-stand article, the marking gauge is set to 1/8". Score the lines lightly around the faces of the leg and again on the top end of each

leg. You want enough of a mark to follow, but you don’t want it to show in the completed chamfer.

Chamfer by Hand – Chisel

To attempt this technique, the cutting edge of the chisel has to be sharp. A dull tool makes this task all that much harder. The aim is to take small cuts, working in from the corners to the middle.

Trim the waste from the corner toward the

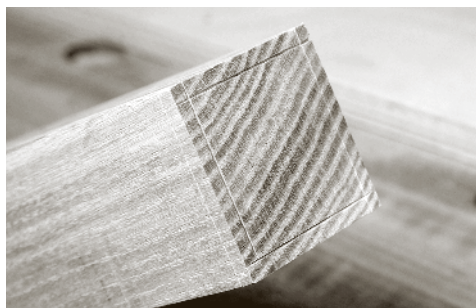

How you mark out your chamfer lines depends on the type of work you plan to do. Add lines to the end grain only if you plan to chamfer with hand tools.



Dull tools waste your time and materials. These damaged corners and rough chamfers are the product of a dull router bit.

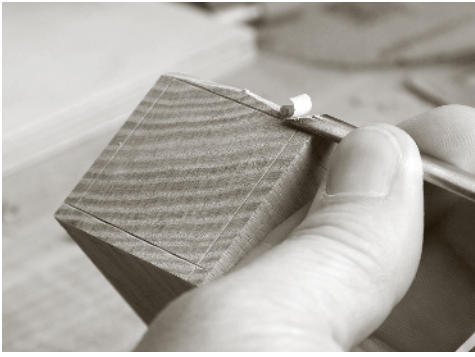

Slicing chamfers with a chisel requires you to work in from the ends and slightly uphill to create a crest at the center of the cut. Once the ends are at your lines, remove the center to complete the chamfer.



Be patient and diligent as you work the chisel. Gently peel away the waste until the chamfer is flat. Steady hands reduce sanding.

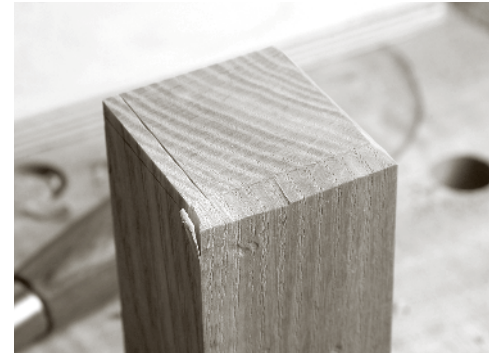

Flake-out at a corner is a result of an inadvertent slip of the hand or improper technique. If this happens, you should start over.

center of the leg and always try to maintain a slight upward slope on the cut. Try to form a molehill, not a mountain, as you work. Once you reach the layout lines at your corners, it's simply a matter of slicing away the center until the chamfer is flat and straight.

Take a good look at this technique and you'll find the "cons" outweigh the "pros" in big way. This technique is good because it's completed with a single tool – although you'll have to sand the chamfer after it's cut, unless you have incredible control with your chisel.

On the downside, not only do your tools have to start sharp, they have to stay sharp throughout the process. Also, different woods influence the work. It's tougher to chamfer oak with a chisel than white pine. And finally, if you do make a cut from edge to edge across the leg, you're all but sure to knock off the trailing corner. Once that's gone, there's no coming back. It's time for a new leg.

Chamfer by Hand – Rasp

Possibly the easiest method for creating small chamfers by hand is to use a rasp. While this too is a one-tool operation, this method requires a certain amount of skill as well.

How a rasp is used is not the issue. That's easy. Grab the handle and start moving the tool back and forth. But if that's all you think about while you work, you're going to create a shape that more resembles a roundover than a chamfer. Achieving a flat surface that terminates at both layout lines takes patience and a bit of self-control.

Use a less-aggressive rasp to cut your chamfer, work diligently across the entire width of your leg and take your time as you work. If you hurry you're liable to remove the tool from the edge during a backstroke. Then, as you re-engage the rasp with the wood, you're likely to dig into the side of the leg causing irreparable damage. (If you use a wide tool, you're less likely to have this happen.)

The trick to get accurate and crisp chamfers with a rasp is to work to both layout lines and remove the majority of the waste area. Then hold the tool at a 45° angle and take the last few strokes to create the desired flat surface. (Due to the coarseness of a rasp, you'll need to finish the chamfer with a very smooth file or sandpaper backed by a wood block.)

Power-tool Chamfers

Turn to power tools and you'll find two easy-to-use techniques for cutting small chamfers: a router table and disc sander. The setup for these techniques is distinctly different, but the outcome with both is quick, accurate and repeatable. And with each, sharp cutting tools (be it a router bit or sandpaper particles) is paramount.

The only method used to cut chamfers where infinite angles are not easily possible is when working at a router table using a chamfer router bit. The choice is limited by the availability of

router bits – unless you manipulate the router table surface or have a specially designed carriage built into your router table. In all, I'm aware of five additional angles, over and above the traditional 45° angles, that are possible with standard router bit designs. This method also eliminates the need for layout lines because once the router table is set and the bit positioned, all cuts are created equal.

Install a chamfer bit into your router, then position the bit and fence for the cut. To match the chamfer on the sample leg, raise the bit 1/8" above the tabletop and position the fence to just capture the bit's bearing.

Because the edges of the leg's top are short, there are two acceptable approaches to make these router cuts – both require the use of a push stick (a proper push block or backer block makes this task safe). The leg can either be vertical when fed over the bit, or it can be laid flat with the end facing the fence.

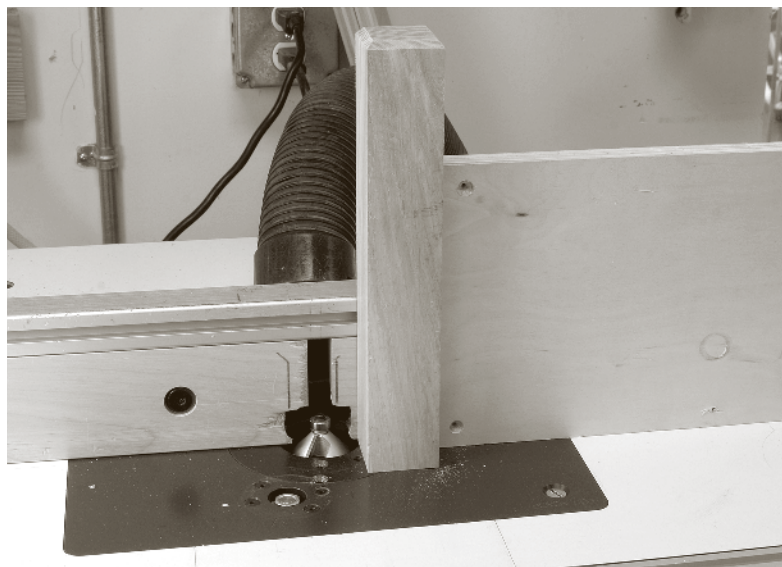

With leg stock vertical, there is little table support under the leg. A push block is a necessity to accomplish your task.

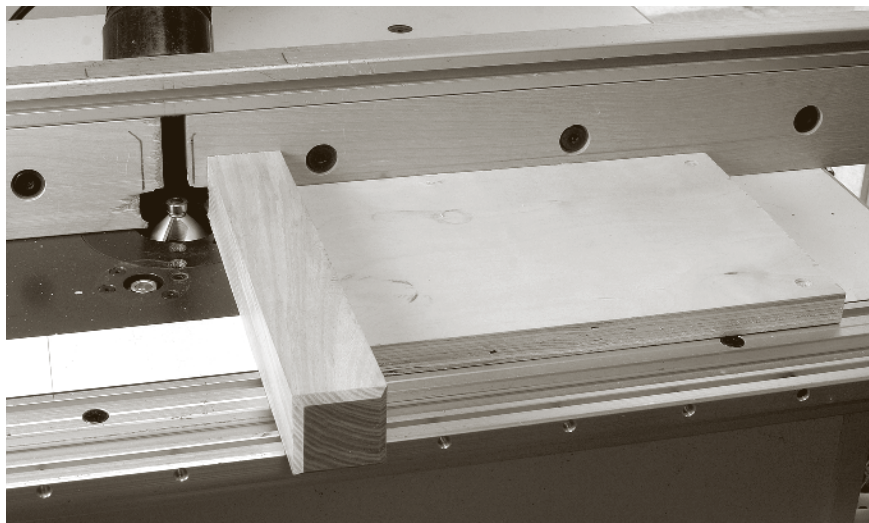

Stock support increases when the leg is laid flat on the tabletop, but even in this position the operation requires a push block.



Profiles of chamfers made using router bit angles other than 45° differ depending on whether the leg stock is run vertical or flat to the table. Here you can see the different chamfers that were cut with a 30° chamfer bit.

Which approach you select is your decision – except when you’re not using a 45°-chamfer angle. At that time you need to decide which approach produces the chamfer angle you’re looking for. (See the photo at top right.)

The jury is out on which approach to use if you’re working with a 45°-chamfer bit. Regardless of how you position the stock, vertical or laid flat, the resulting chamfers match. Some woodworkers find feeding vertical leg stock over a bit is awkward. Others don’t. Try the two approaches to determine which you’re most comfortable using.

A chamfer cut at a router table is very crisp (the result of a sharp bit) and is easily repeated on any number of legs. One issue that may arise is machining marks caused by well-worn router bits. These marks tend to be magnified when stained, so check the chamfer and make sure to sand the flat surfaces carefully.

Disc-sander Chamfers

Because the chamfers are small, a disc sander, whether a stationary tool or simply an accessory on your table saw, is a viable option. I would steer you away from this technique if the chamfers are

large, long (wider than a sanding disc) or oriented to long grain instead of end grain. But for our project, this method is a good one.

Begin by marking layout lines around the faces of the leg. Next, set a miter gauge at an appropriate angle – here again you have infinite angles available. Position the gauge at the sander so the end of the leg makes contact on the downward cutting portion of the spinning disc.

This technique requires you to do two things at once (similar to rubbing your head while patting your stomach). If you simply move the leg stock against the disc, the chamfer is cut, but the charred-from-burning color is not pleasing. To cut a clean chamfer, push the leg in toward the

sanding disc as you move the workpiece across the disc.

Work to your layout lines, then rotate the stock and cut the next chamfer. This is a quick technique and your chamfer is crisp, clean and ready for finish. The downside is that you control the depth of cut. It’s easy to overfeed the leg and there is no easy way to set stops.

I’m a power-tool woodworker – so you can guess which methods I like best. Maybe it would be best to combine the repeatable results from a router table with the perfectly sanded outcome from a disc sander to create the ultimate small chamfer. Is that being too particular? **WM**

— Glen D. Huey

“I will not give away my hard-earned skills to a machine. It’s a bit like robbery with violence, for (machines are) not only intended to diminish my bank balance, but also to steal my power.”

— John Brown (1932-2008)
Welsh stick chairmaker



The rotation of your disc sander plays a big part in the setup. It’s vital that you introduce the leg stock on the downward portion of the disc. Move across the disc as the chamfer is being cut to reduce burning the surface. A light touch is needed.

Glossary

“The right word may be effective, but no word was ever as effective as a rightly timed pause.”

— Mark Twain (1835 - 1910), American author

Woodworking’s lexicon can be overwhelming for beginners. The following is a list of terms used in this issue that may be unfamiliar to you.

boiled linseed oil (n)

Linseed oil is a traditional finish and shop lubricant (it was used to grease the soles of handplanes). Extracted from the flax plant, raw linseed oil will take weeks or months to dry when it comes in contact with oxygen. Historically, linseed oil was heated to help it accept a lead drier to make it dry faster. Today, linseed oil is treated with modern driers, yet it is still labeled as “boiled linseed oil.” As a finish, boiled linseed oil is simple to apply, but it offers little protection and must be renewed regularly or the project will look dull and lifeless.

build up (v) or **buildup** (n)

When adding a film finish to a project, several layers are required for the film to protect the wood and look acceptable. In finishing parlance, it is said that you need to “build up” a finish. The expression is also used as a noun to convey that you have added too many layers of finish: “You have too much buildup and your finish looks like plastic.”

expressed joint (n)

Where the structural details of a joint are allowed to show in finished work. Typical expressed joints include through-dovetails and through-tenons.

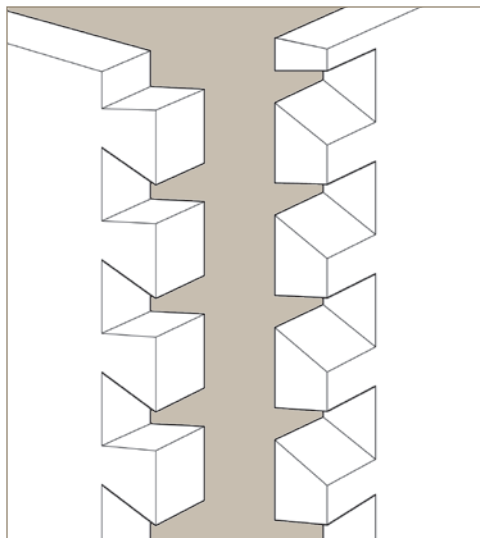

Through-dovetail joint

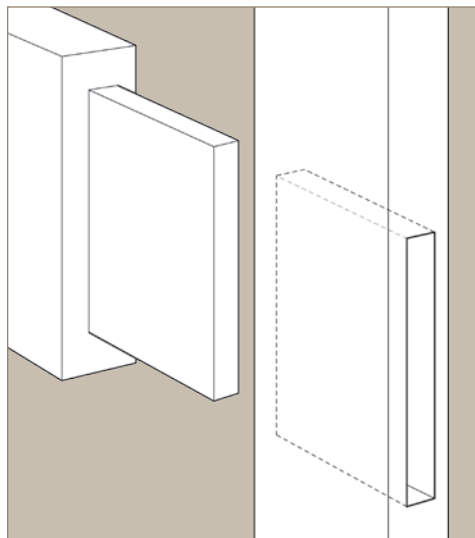

Through mortise-and-tenon joint

ILLUSTRATIONS BY LEN CHURCHILL

In much high-style work, woodworkers sought to hide the structure of all joints. In modern work since 1900, expressed joinery can be used as an outward display of build quality.

flash off (v)

An expression used in finishing. When the top-most layer of a wet finish turns from shiny to slightly dull, it is said to “flash.” When it has flashed, it is not dry but has begun to set up. When many finish products flash, that usually is the time to wipe them down to remove the excess.

Forstner bit (n)

Invented in 1874 by Benjamin Forstner, this style of boring bit is used to create clean, flat-bottomed holes with very little penetration by the central spur. This makes them ideal for stopped holes compared to the traditional auger, which has a long lead screw. Forstner bits also offer the woodworker the ability to overlap holes without the bit wandering, which is difficult to achieve with twist or Brad-point bits.

Morris chair (n)

A style of chair named after William Morris, the founder of the English Arts & Crafts movement. Despite the name, the chair was not invented by Morris, but by one of his associates. The Morris chair is characterized by an adjustable back and is widely considered the spiritual progenitor to the La-Z-Boy chair.

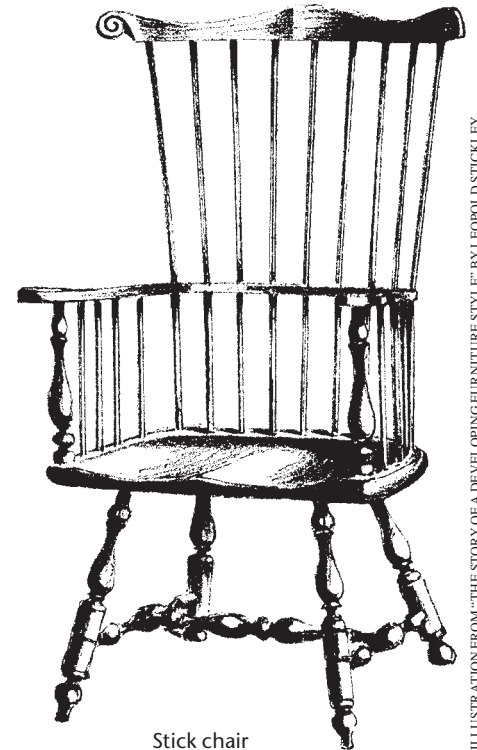

Stick chair

ILLUSTRATION FROM “THE STORY OF A DEVELOPING FURNITURE STYLE” BY LEOPOLD STICKLEY

stick chair (n)

A style of chair where the strength of the chair is contained in its solid-plank seat. The legs are drilled and wedged into the seat, as are the spindles that support the arms and crest rail. Stick chairs are distinct from frame chairs (e.g. ladderback chairs), which derive their strength by a series of intersecting posts and rungs. The seat on a frame chair is traditionally woven or loose.

tack rag (n)

A cloth that has been impregnated with resin or a varnish-like material. The rag is used to remove loose dust from projects after the finish has been sanded.

tear-out (n)

When small chunks of grain have been torn from a board, creating an undesirable gash. Tear-out typically occurs when a cutter encounters a section of grain that allows the cutter to get under the grain and lever the fibers upward. This forces the actual cutting action to occur in front of the cutter, instead of right at the knife. When this occurs the wood tears instead of being cleanly sliced away. **WM**

Hanging Shelves

This simple project with authentic details provides practice with little risk, and a handsome and useful display.

Hanging shelves are one of the most adaptable projects in woodworking. A small shelf can fill a need in the kitchen or bath, while a larger one can hold books in the den, or a collection of tools in the shop. The method of making them provides an opportunity to develop skills and use leftover material. It's all a matter of scale.

The illustration at right shows some variations in size and shape, and the techniques for making the shelves (and attaching them to the wall) are a good way to practice your joinery. If the project turns out well, put it in the living room. If the end result contains flaws, find a dark corner in the guest bathroom or a dusty place in the shop.

Size the components based on the overall size and the intended purpose. I wanted a small set of shelves for spices in the kitchen or small cosmetic items in the bath. These shelves are 4" deep and the overall height is 20". While sketching, I settled on an overall width of 13³/₄". I milled the ash boards I had to a thickness of ⁵/₈" to maintain an overall sense of proportion.

I milled all of the stock to 4" wide and cut the parts to the lengths given in the list. All of the shelves finish ¹/₈" narrower than the sides, but I waited until after making the through mortise-and-tenon joints to reduce them in width. This left a little leeway for fitting the joints.

With both side pieces next to each other on the bench, I oriented them with their most attractive surfaces facing out, and I laid out the locations for the through-mortises. I used a wheel marking gauge to incise the edges of the mortise locations. This gives a more precise location than a pencil line, and when it comes time to clean up the edges of the mortises, it's easy to see where to stop.



PHOTO BY AL PARRISH

A simple set of hanging shelves is enhanced with decorative joinery, hidden shelf supports and a hanging method that shows no fasteners.

Method to Make Square Holes

I decided to forego using a hollow-chisel mortiser or a router with a jig to make the through-mortises. The small size and location across the width complicated the setup for either of these options. Instead, I removed most of the waste with a ⁵/₁₆"-diameter Forstner bit in the drill press. I set a fence on the drill press table to center the bit in the mortise at the top of the sides vertically, and drilled a series of overlapping holes.

"In theory, there is no difference between theory and practice. In practice there is."

—Yogi Berra (1925 -)
former Major League Baseball player and manager

After resetting the fence, I drilled another series of holes to locate the bottom mortises. Making the mortises this way involves some risk of tearing out the wood on the back of the joint. This can be minimized by knifing in the layout lines on both sides of the joint, and using a piece of scrap wood below the work when drilling and paring.

Using a ³/₄"-wide chisel, I pared away the scallops that remained where the holes overlapped. As the scallops disappear, and the paring cuts get closer to the edge of the mortise, it takes more effort to make these cuts. I positioned my shoulder directly over the chisel so I had extra leverage as I pushed down. It's also easy to sight along the back of the chisel to be sure it is vertical from this position.

After working the wide top and bottom edges, I used a ¹/₄"-wide chisel to pare the ends of the mortises down to the lines. A cut in this direc-

Hanging Shelves

NO.	PART	SIZES (INCHES)			MATERIAL
		T	W	L	
2	Sides	5/8	4	20	Ash
2	Fixed shelves	5/8	3 7/8	13 3/4	Ash
2	Adjustable shelves	5/8	3 7/8	12 1/4	Ash
1	Cleat	5/16	1 1/4	12 1/4	Ash
2	Cleat	5/16	5/8	12 1/4	Ash*

* 45° bevel on edge, one piece attaches to wall, the other to the top shelf

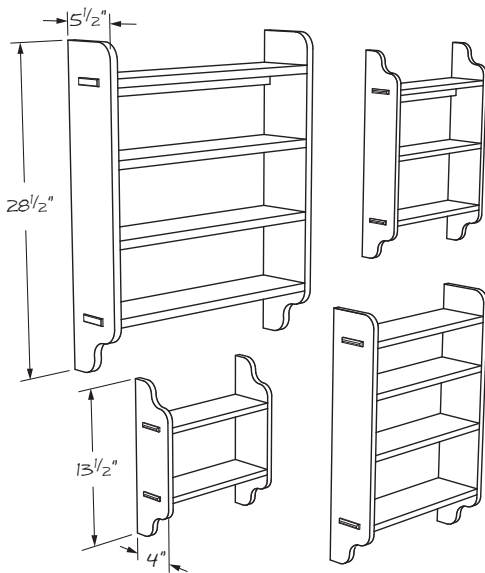

Simple hanging shelves can be made in a number of sizes and shapes. You can hone your skills and fill a need at the same time.

tion is trickier to control, even though the effort to make the cut is easier. These cuts go with the grain, so taking too big a bite can cause the wood to split along the grain.

I stopped paring when the cuts got close to the layout lines and switched from a chisel to a rasp for the wide parts of the joint, and a small flat file for working the ends. This gave me more control and a better surface for the last few cuts that define the mortise.

With one hand above and the other hand below the work, hold the rasp vertically and watch the flat side of the rasp and the layout line as cuts are made on the down stroke. Use the same technique with the file to create a crisp line and corner on the end of the mortise. Use a small adjustable square frequently to check the joint.

In addition to the lines on the finished face being straight and square to each other, I also

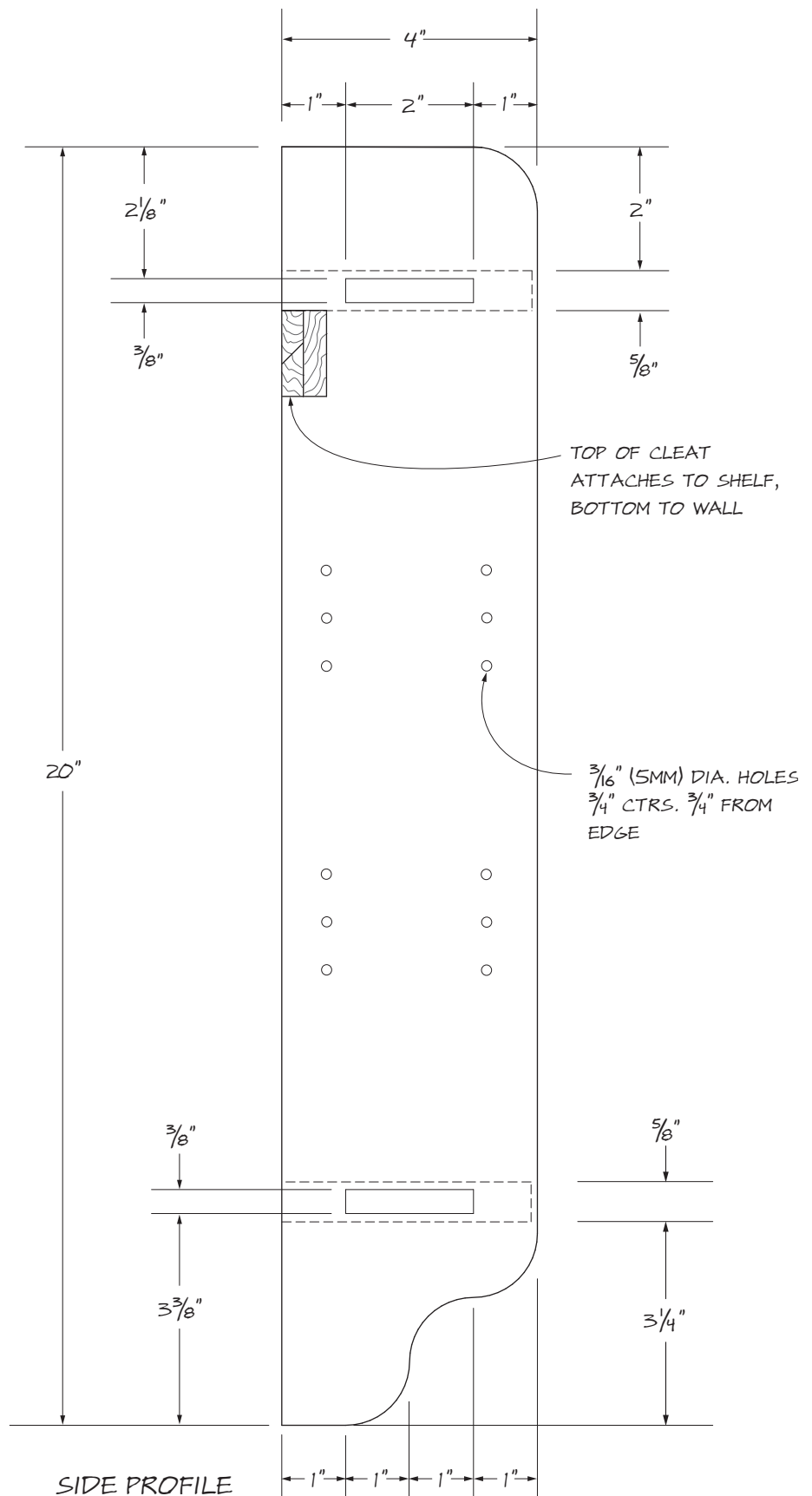

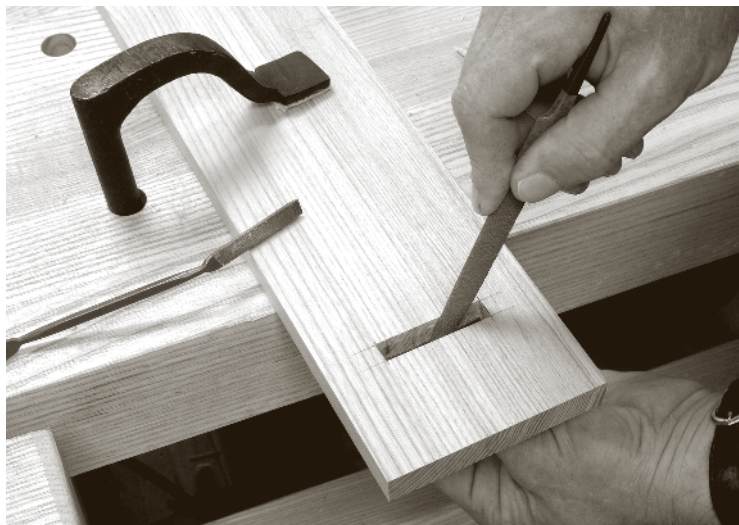

After paring close to the layout lines, a hand-cut rasp is used to remove the last bit of material, leaving a straight and crisp line.



A small flat file is ideal for perfecting the ends of through-mortises.

checked that the walls of the mortise were square to the face of the board. If there is some variation, it should be held to the inside face of the board. The joint will still function if the mortise isn't perfect, but to look good it must be a tight fit on the show side.

Tenons to Fit

On a good day, all the mortises will be the same size. I used a pair of fractional dial calipers to check before cutting the tenons. Just as there are many ways to make the mortises, there are a number of methods to make the tenons. I set up a 1"-diameter straight bit in the router table, with the edge of the bit $13/16$ " from the edge of the fence. I set the height of the bit lower than I needed to keep from overcutting the tenon cheeks.

Using a square scrap of wood as a push block, I ran the end of a shelf along the fence and over the bit. I then flipped the board over to cut the other side. Using the calipers, I measured the resulting tenon to compare it to the mortise size. This method of trial and error ensures that the errors land in scrap wood and don't result in a skinny tenon. I made slight adjustments to the bit height to make the tenons a few thousandths of an inch bigger than the mortises.

I fit the tenons for height first, placing a corner into the mortise and removing small amounts of material with the rasp held flat across the tenon cheek. When I could force each corner into the mortise, I placed the shelf vertically on the side, lined up the edges of the shelf and side, and marked the ends of the tenon directly from the mortise.

I used a dovetail saw to remove the excess material from the tenon, cutting close to, but just outside the pencil line. Again, this keeps any error manageable without ruining the part. After sawing, I used a chisel, then a rasp, to work the tenon down to the finished size. Before giving

the tenon a test fit in the mortise, I put a small chamfer on the ends of the tenon with a rasp. I also put a very light chamfer around the inside edge of the mortise. These chamfers help get the joint assembly started, and they keep damage to a minimum as the tenon comes through the show side of the mortise.

In theory, the joint should come together with hand pressure. I aim for that, but it almost always takes a few tries to get the fit just right. I push until the tenon gets stuck, then take the joint apart by tapping on the inside of the mortised piece with a dead-blow hammer. Tight spots will show as shiny areas where the two pieces rubbed each other. If you have trouble seeing them, rub the tenon with a soft pencil and push it into the mortise as far as you can. When you take the joint back apart, you

can see where the graphite has rubbed off.

If the wood is hard, you can get away with lightly tapping around the mortise to get the joint together. The wood will make a different tone in tight areas than it will in loose ones. It takes some experience to know where to hit and how hard to hit. The risk is splitting the wood, and it doesn't really work to beat on it until something breaks, then beat it a little less.

I make most of the adjustments to the tenon, unless I discover a high spot within the mortise. This is a process of testing the fit, taking the joint apart, making a few strokes with the rasp then testing the fit again. I switch to a card scraper at the very end, aiming for a finished surface on the exposed part of the tenon as the final fit is reached.



Holding the rasp at a 45° angle quickly brings the chamfered ends down to the layout line.

Turning the Corner

When the joint finally goes together, I find something – either a metal straightedge or a scrap of wood that is as thick as half the exposed portion of the tenon. In this piece, the end of the tenon protrudes $\frac{3}{16}$ " beyond the face of the side, so I laid a $\frac{3}{32}$ "-thick straightedge against the side, and marked around the tenon with a pencil. This established the limit of the chamfers on the tenon ends, which I cut with a rasp.

Before disassembling the sides and shelves, I marked the edges of the shelves so that I could trim them to be flush at the back, and $\frac{1}{8}$ " in from the front edge of the sides. I made the rip cuts on the table saw, then I used a block plane to remove the saw marks and chamfer the shelf edges.

With the joints fit, I used double-sided tape to temporarily hold the two sides together, oriented with the outside faces out and both front edges together. I then laid out the curved profiles at the top and bottom. I used my adjustable square to draw a grid on one side, and a compass set to a 1" radius to mark the curves.

I cut the curves at the band saw, and removed the saw marks with an oscillating-spindle sander. The sander is nice to have, but these edges can also be cleaned up with the curved side of the rasp, followed by a card scraper.

Room for Adjustment

After taking the sides apart, I laid out the holes for the adjustable shelf pins. I marked the holes on $\frac{3}{4}$ " centers, $\frac{3}{4}$ " in from the front and back edges. I spaced the sets of holes so that the shelves would

divide the space in thirds when the shelf pins were in the center holes of each group of three. After marking, I drilled the $\frac{3}{16}$ "-diameter holes at the drill press. I used small brass shelf pins, with a 5mm shank. This was a tight fit in the $\frac{3}{16}$ " holes, but it worked.

I didn't want the shelf pins to be visible, so I used a $\frac{3}{8}$ "-diameter core box bit to cut two stopped grooves in the underside of each end of each shelf. I set up the bit in the router table, with a square block extending from the fence to guide the edge of the shelf as I pushed the shelf into the bit and against the fence.

After sanding all the parts with #120 grit with a vibrating sander, then with #180 grit by hand, my shelf was ready to assemble. Before assembly, I brushed yellow glue on the end-grain surfaces of the mortise and the shelf. After letting this dry for 10 minutes, I started the tenons in the mortises, and brushed glue on the cheeks of the tenons. I was frugal with the glue so that there wouldn't be any squeeze-out to clean up.

With all the tenons in place and the glue applied, four bar clamps brought the assembly together. I removed the small amounts of glue squeeze-out with the back of a sharp chisel and a damp rag, and then I let the work sit in the clamps overnight. After removing the clamps, I lightly chamfered the edges of the sides and shelves with a fine rasp and a piece of #120-grit sandpaper.

To hang the shelf from the wall, I milled some scrap stock to $\frac{5}{16}$ " thick. After establishing the length to fit within the sides of the shelves, I ripped one piece of this thin stuff to $1\frac{1}{4}$ ". I set

Supplies



Rockler

800-279-4441 or rockler.com

1 ■ brass shelf pins
#22252, \$3.99 pkg. of 16

Price correct at time of publication.

the blade of the table saw to cut a 45° bevel and the fence to rip two pieces $\frac{5}{8}$ " wide. I glued one of these angled pieces to the flat piece, as seen in the photo below right.

When the glue dried, I planed the edge where the two pieces met flush, and glued this assembly to the bottom back edge of the top shelf. I set the other angled piece aside to screw to the wall. The angled edge attached to the shelves drops over the angled edge of the piece attached to the wall. This provides a secure connection, and the only thing visible from the front of the shelves is the face of the piece below the top shelf.

I hand-sanded all the pieces with #180-grit Abranet (an abrasive mesh) before staining. I applied a heavy coat of Olympic "Special Walnut" oil-based stain with a rag, let it sit for 10 minutes then wiped off the excess. For a topcoat, I sprayed semi-gloss lacquer from a can, sanding between coats as described in the article on page 30.

A small simple project such as this is a good way to spend some time in the shop, and have something useful and attractive to show for it. **WM**

— Robert W. Lang



Stopped grooves made at the router table with a core box bit hold the shelves securely and conceal the shelf pins.



The completed through mortise-and-tenon joint is incredibly strong, and it adds a decorative accent to a simple project.



A hidden French cleat slips over a matching angled cleat to hold the shelf to the wall.

Saddle Squares

This little slip of a layout tool is an excellent way to transfer layout lines around corners.

There haven't been too many innovations in the last couple centuries when it comes to the basic cadre of layout tools. But a little more than a decade ago, Bridge City Tool Works introduced the "saddle square" as a "straightedge for corners" to more accurately mark lines around corners, according to Bridge City's founder John Economaki. For the relatively few woodworkers who have used one, this handy little tool has changed layout immeasurably for the better.

Transferring a line from one surface to an adjacent surface with a combination square or try square is never easy because you have to move the tool to do it. (Try to quickly wrap a line around a piece of stock with a combo square, and you'll see how easy it is to muck it up.) A saddle square allows you to keep the tool tightly in contact with both stock faces as you make the mark, cutting down on the possibility for error.

Both Bridge City and Veritas (the toolmaking arm of Lee Valley Tools) now offer two sizes of commercially made saddle squares, but we found that in a pinch, a well-made butt hinge (without balls or finials) also works well (just be sure to choose one with no hinge slop). Actual saddle squares are, however, more handy because they can mark longer distances, and they're easier to hold to the work with one hand (the articulated Bridge City versions are tightly joined, so they don't easily slip in use).

"Though he may not always recognize his bondage, modern man lives under a tyranny of numbers."

— Nicholas Eberstadt (1955 -)
American political economist and demographer



PHOTO BY AL PARRISH

Saddle squares are designed to transfer layout lines from one face of a board to a second adjacent face, without moving the tool. A well-made hinge works, too, though the legs may prove a bit too short in some layout situations.

For looks, I prefer both of the Bridge City versions, but in ease of use, I found the ridges on the faces of the Veritas versions, as well as the wider faces, allowed me to more easily hold the tool to my work. However, the Veritas saddle squares work only on 90° corners, so if you're a chairmaker, or commonly work with angles other than 90°, consider the Bridge City tools (or a good hinge).

I've also found the saddle square a must-have at the table saw for cutting my work to size. Sure,

I could lay my tape measure along the edge of a board and mark the cut, but sometimes it's hard to balance the tape or a rule on thin stock. It's easier to mark the workpiece face, then transfer the mark around the edge and "show" that mark to a sawtooth to accurately set the saw's rip fence or the stop on a crosscut sled.

For the time it saves on layout and the little space it takes up, we think a saddle square is a must-have tool. **WM**

— Megan Fitzpatrick



In this panel glue-up, you can see the the board lengths aren't equal. In this scenario, it's hard to balance a measuring tool on the end to mark the width. With a saddle square, it's simple to mark the face and accurately transfer the line around to the edge, then line up the blade to the mark.

Saddle Squares

BRIDGE CITY

SS-2 Brass and Rosewood Saddle Square

This was the first saddle square on the market, and in addition to its usefulness, it's nice to look at. Articulation allows for tight work on non-90° corners. The version with two 2"-long legs is ideal for typical layout work and takes up little space in your shop apron.



Bridge City Tools ■ 800-253-3332 or bridgecitytools.com
Retail Price ■ SS-2 (2" x 2" legs), \$69
(2" x 4" legs), \$72

BRIDGE CITY

SS-2X4 Aluminum Saddle Square

This aluminum version from Bridge City is a less expensive option than the company's brass and rosewood tool, and is available only in the 2" x 4" size. The matte black finish is sleek looking, and it's grabby on your fingers as well as on your work. Articulation allows for tight work on non-90° corners.



Bridge City Tools ■ 800-253-3332 or bridgecitytools.com
Retail Price ■ \$44

VERITAS

Saddle Square

This inexpensive anodized aluminum saddle square has 1¼" x 2¼" legs, and is machined square with no articulation; that makes it useful only for 90° work (which is 98 percent of what most woodworkers routinely do). Also, the larger face makes it a little easier to hold to the work than the Bridge City versions. While this Veritas tool is not as snazzy looking, it's functional and inexpensive.



Lee Valley Tools ■ 800-871-8158 or leevalley.com
Retail Price ■ \$14.50

VERITAS

Large Saddle Square

This larger version of the Veritas saddle square has 1¾" x 3¾" legs, which accommodates a standard 2x4 for stud-wall layout; the slot through the center makes it easy to mark a stud's center. It's also useful for marking lines on larger stock for woodworking projects because of its one long leg.



Lee Valley Tools ■ 800-871-8158 or leevalley.com
Retail Price ■ \$16.50

Butt Hinge

An inelegant but readily available solution is to find a well-made hinge in your stock of odd hardware. Just make sure there's no slop in the leaves (and you might want to check the hinge against a square you know is accurate before using it for layout).

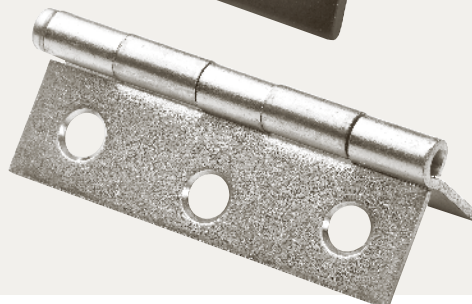

Any hardware store
Retail Price ■ varies

A Super Smooth Surface

Fillers level open-grain wood in a single step and save time.

Some woodworkers like the look and feel of grain on their projects while others strive for a super smooth surface. Be it high sheen or dead flat, a super smooth surface requires work during the finishing stage of your project.

Chances are your normal finishing supplies or methods of work won't produce a smooth finish unless you're working on closed-grain woods such as maple or cherry. With these woods, it's possible to fill pores and level the surface using most topcoat materials while sanding between layers until you achieve a smooth surface.

On the other hand, open-grain woods, such as walnut, mahogany or oak, need additional work to attain super smooth status. The grain must be levelled by filling the pores. Depending on your final finishing approach – staining the project or simply leaving the wood natural – you have a few options.

If you plan to finish your project without stain, then sandpaper and oil might be your best choice. If you plan to enhance the color with stain, you can use excessive coats of finish. Given enough time to apply then sand off topcoat material, you can eventually fill even the most open-grained hardwoods. Or you can use grain filler.

Grain filler, sometimes called pore filler or paste wood filler (but not wood putty), is a combination of filler material, binder and usually some type of colorant.

Silica, calcium carbonate or clay is usually the filler material. The binder is either oil or varnish in oil-based filler, or glycol if it's water-based.

As for a colorant, most oil-based fillers have a colorant added – even those listed as “natural.” Oil-based fillers can be shaded with compatible stains or concentrated colors as can water-based



PHOTO BY AL PARRISH

To achieve a super smooth finish, open-grain wood has to be filled and there's more than one choice for filler. The product, and the method used to apply that product, directly influence the final appearance.

fillers, but water-based fillers are also available as “clear.” When clear filler dries, the filler material becomes translucent and does not affect the final finish appearance, as color-added fillers do.

Stain-free Projects

On a project where you need to fill the pores and stain is not required, I suggest a coat of boiled linseed oil (BLO). Then sand the piece with #400-grit silicon-carbide sandpaper while the oil is wet. This

action mixes wood dust from the project into the oil to create a slurry. That slurry, in turn, fills the open pores. This process is quite effective, but it might require you to add a couple extra layers of finish to make the surface super smooth.

Yes, the addition of BLO will affect the finish appearance. If you want to lessen the yellowing brought on by BLO, use tung oil. And if tung oil is still a bit more yellow than you wish, switch to a clear water-based filler.

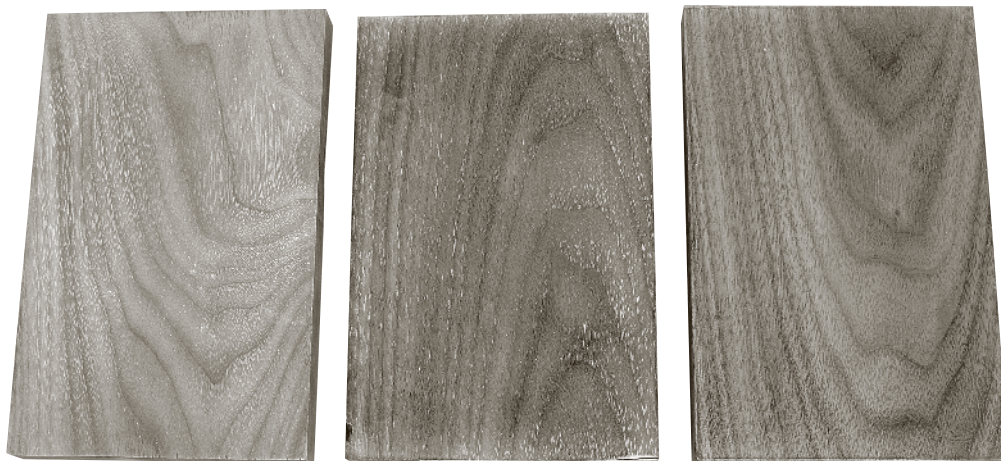

After a coat of sealer and a light sanding, non-filled areas stand out due to sanding dust left in the still-open pores. The left-most sample began as raw wood while the center sample has an oil/sanding filler. The right-most sample, the piece clearly more filled than its counterparts, has two coats of water-based filler added.

“It often requires more courage to dare to do right than to fear to do wrong.”

— Abraham Lincoln (1809-1865)
16th president of the United States

Stained Projects

Apply color-added filler directly on your project and the filler is essentially a stain. Unless you experiment with fillers as stain and are happy with the results, I suggest you first stain and seal the wood (for which I like shellac). As you sand the sealer coat, you fold any peaks of sealer into open pores. That helps fill the pores so less filler is needed to level the surface. Then add paste filler.

It’s at this point in the finishing process that you need to decide on the final appearance you want. Are you looking for a clear filler to keep the appearance as-is? If so, water-based filler is your only choice. Would natural or light-colored filler work with the stain you’ve selected? Or, would a dark-tinted filler add to the overall look of the project when complete? In either case, you have the option of oil-based or water-based fillers.

I prefer dark-colored filler for most projects. In the same vein as filling nail holes, many hardwoods darken in time while the color of the filler remains constant. Any differences in the two shades are amplified as the piece ages. One caveat to this is walnut. Walnut lightens with age, so you need to evaluate the stain color in order to reach a decision. However, if you’re not staining walnut, you should use the oil/sanding method described above.

Oil-based vs. Water-based

Perhaps the most important question to ask is whether water-based filler or oil-based filler is better. There are pros and cons with each of these two varieties of fillers.

Water-based is easy to apply and cleanup is a breeze. Simply wipe the filler on using a circular motion to help force particulate into the pores, wipe off any excess and let it dry. Keep a close eye on this step because sometimes water-based fillers dry too fast. I needed to apply a second coat of filler to completely fill the pores of both walnut and mahogany when using a water-based filler.

Once it’s dry, you’ll need to sand the filler to level the surface. With sanding comes the risk of sanding through the filler and stain, exposing bare wood. If that happens, start over.

I prefer oil-based filler if I plan to fill open-grain hardwoods. Application of oil-based products is more involved than water-based products because there’s an additional step. First, wipe or brush oil-based filler onto a previously sealed and sanded wood, again using a circular motion. Because oil dries more slowly than water, you need to keep an eye on this filler until the sheen



Water-based filler dries very quickly. Here you can see swirls from the application of the product. Make sure to wipe excess water-based filler from the project while moving with the direction of the grain.

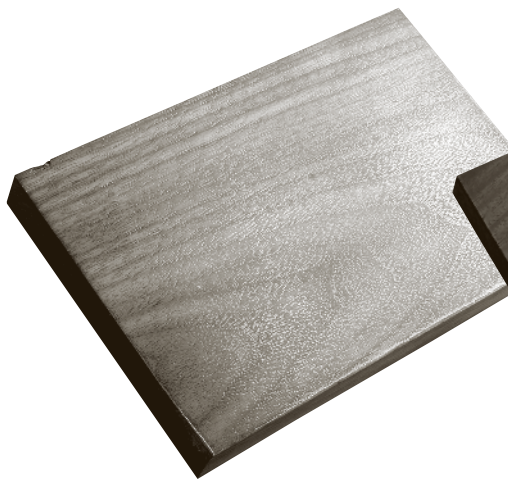

This sample of walnut was filled with an oil/sanding dust filler, followed by three layers of sanded shellac. Holding the piece under a raking light shows that more work is needed to gain a super-smooth surface – dull areas are level and shiny areas (white areas under reflected light) are yet to be filled entirely.

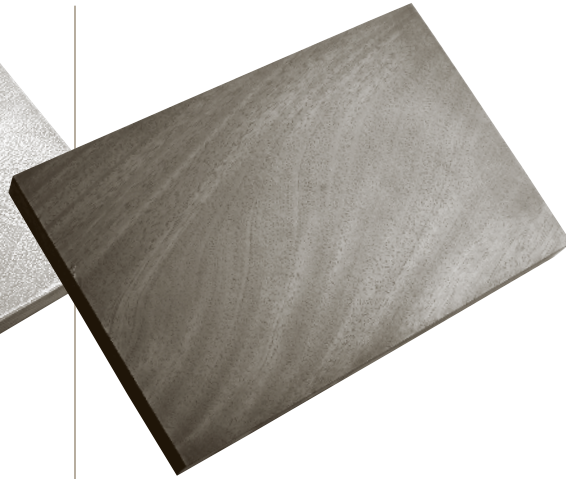

A dark-tinted oil-based grain filler levels the surface in a single step and adds a deep tone to the overall finish. This is especially nice when you wish to add age to a finish such as on reproduction furniture.

flashes off to a dull haze. At that time, scrape the excess filler from the surface, then wipe with a coarse cloth – burlap is an excellent tool. Wipe across the grain, not with the grain. When you wipe with the grain there’s a chance to pull filler from filled pores and then you’ll have to apply it again.

Allow the oil-based filler to dry before you add a sealer coat or other topcoats.

For my test, one application of oil-based filler significantly filled the pores on both walnut and mahogany.

Once the grain is filled to a level surface, it’s on to your topcoat. If you select a water-based filler, there should be zero compatibility issues. However, if you use an oil-based filler, lightly sand the surface with an abrasive pad to remove any airborne dust particles. Then, due to compatibility issues with some topcoats, apply a sealer over the

filled surface. For me, another coat of shellac is the best choice, after which any finish is OK. (If filler is allowed to thoroughly and completely dry, a sealer coat over the filler can be skipped, but I prefer to play it safe.)

If a super smooth surface is what you yearn for, give filler a try. It works. But a word of caution: If you’re looking for a “piano” surface – that super-high-gloss sheen – you’ll still have to apply a significant number of topcoats to achieve a level surface that won’t show grain in reflected light. That’s why most furniture is finished with a dull or hand-rubbed finish. A dull finish does not reflect light as much, so hiding minute imperfections is possible.

As with all finishing techniques, it’s best to practice on a piece of scrap from your project lumber to assess the end result. ■■■

— Glen D. Huey

Sanding Finishes blog

The opportunity to make or break the look of your project. We look at the techniques and some new materials.

As the completion of a project approaches, the temptation to rush and be done with it is strong. But the final steps of applying a first-class finish are as important as the first steps of laying out and building. Careless work at this point can compromise the final appearance, or create problems that may take an enormous amount of time to correct – or both.

Sanding between coats of finish is often glossed over in books and magazine articles. Many woodworkers don't understand what they are sanding, why they are sanding or how to do it efficiently and effectively. The goal is a smooth and flawless surface. But the goal of perfection is elusive, and a surface that looks and feels smooth and flawless is a reasonable compromise.

There are two types of finishes that need to be sanded between coats: reactive finishes (lacquer and shellac, for example), where the solvent of a fresh coat partially dissolves the finish beneath it; and non-reactive finishes (such as varnish), where the solvent has no effect on underlying coats.

The techniques for sanding are much the same, but leveling one coat of varnish before applying another requires a more thorough and careful approach. Oil finishes can be wet-sanded during application and wiped dry. If any oil dries on the surface, it should be sanded between coats.

*"You throw the sand against the wind
and the wind blows it back again."*

— William Blake (1757-1827)
English poet, painter and printmaker



PHOTO BY AL PARRISH

Careful sanding between finish coats will make the difference between a tolerable finish and a great one. You don't need to worry about following the wood grain, but there are plenty of other things to consider: the right abrasive, the proper technique, and getting rid of dust and other debris.

In a perfect world, gravity would let a finish flow out to a perfectly level surface before a finish could dry. And in this imaginary perfect world, all surfaces would be horizontal. In reality, however, the pores in the wood and uneven application from a brush, rag or spray gun all prevent any finish from becoming absolutely level before the finish dries, no matter how careful the finisher may be.

In addition, dust and other airborne objects will find their way to the surface, even in the cleanest of finishing rooms. The goal of sanding between coats is to remove – or at least disguise – these imperfections, leaving a smoother and flatter surface with each subsequent coat.

Given enough time and many coats of finish, a nearly perfect, high-gloss finish can be achieved. Not every project is a grand piano, however, and for most work a lower sheen that shows evidence of the pores of the wood is desired. This sort of finish doesn't take long, and can be achieved in a few coats with the right technique.

Sanding a finish is an exercise in restraint, particularly if there is a layer of stain between the finish and the wood. You want to level the

surface without removing any color. Preparation before staining will eliminate most of that risk. Use a plane, scraper or sanding block to ensure level, flat surfaces.

Avoiding Low Places

A common mistake on raw wood is to sand low spots. If you have a dent or a dip, sanding directly on it won't help; you need to sand everything else down to that level. After sanding all the flat surfaces, lightly go over the edges, breaking any sharp corners. This will keep the stain and any following coats from building up at the edges.

Finish sanding is also an exercise in patience. Lacquer, varnish and shellac will be dry to the touch long before they are completely dry. You can sand these surfaces when they are dry to the touch, but just because you can, doesn't mean that you should. These coatings will tend to pill up if you don't wait overnight before sanding.

Few woodworkers are that patient, and one of the attractions of these finishes is the fact that you can apply several coats in a short period of time. Many products developed for sanding fin-

ishes have been engineered to minimize pilling in uncured finishes, but some of these introduce other problems.

Minimize the Risk

White colored, stearate-coated papers are lubricated to keep from loading the paper with sticky sanding residue, but this lubricant can interfere with the adhesion of subsequent coats in some finishes such as water-based lacquer.

Sanding with a sheet abrasive alone is the riskiest approach, and it requires a light and careful touch around the edges. Grain direction doesn't matter, because you are sanding a film rather than the wood below it. The direction of your fingers in relation to the paper is more important. Keep the motion of the paper at a right angle to your fingers to even out the pressure and avoid introducing finger-shaped grooves.

A sanding block will even out pressure from your hand, but a rigid block can cause problems. If the finish starts to pill below a hard block, it can leave a groove or even tilt the block so its hard edge sands through the stain at another point. A good sanding block has some give to it. Traditionally, a layer of cork on a block of wood is used.

A recent addition to the sanding arsenal is the sanding sponge, and this is my weapon of choice for finish sanding. It is the right combination of stiffness to keep flat surfaces flat, with enough give to go around corners and over bumps. It can also reach to sand faces on an inside corner simultaneously, as seen in the photo below.

If the finish starts to pill and build up on the abrasive surface, it can be knocked loose by tapping the sponge on a hard surface, or by rinsing it under running water.

There are two other useful abrasives that are easily cleaned, and these also provide space for the little goobers of finish to go while sanding.

Non-woven nylon abrasive pads don't work as quickly as sandpaper or a sanding sponge, and they need to be held and moved correctly on a flat surface. But they are great when you need to wrap them around a corner, or scrunch them into

a moulding profile. If the pad begins to load up, it can be cleared by shaking it or snapping it, and it can be rinsed in water or a solvent.

A New Favorite

The other new and notable abrasive is Abranet, recently introduced by Mirka. Abranet comes in sheets and disks, but it isn't sandpaper. It is abrasive-impregnated mesh. As you sand with it, the dust and residue can move through the open spaces in the mesh. Mirka makes some sanding blocks designed to be used with Abranet that connect to a vacuum hose – an effective, inexpensive and almost dust-free sanding solution.

Abranet lasts a long time, and if a slightly sticky finish begins to fill the spaces in the mesh, you can clear them easily. Grab each side of the sheet, bring the edges together and quickly snap them apart. If that trick doesn't work, you can blow compressed air from the back side of the sheet. If all else fails, rinse the sheet in solvent.

After sanding, the fine powdery dust must be removed before applying the next coat of finish. Compressed air can be used, provided that there isn't so much dust that it will form a cloud that will settle back on the surface. The residue can

Supplies



Mirka Abranet
amazon.com

be vacuumed off with a brush attachment, but the bristles should be short and soft. The vacuum is more effective than blowing, but will take longer and require more attention to make sure no areas are missed.

The alternative to an air attack is wiping the sanding residue away. A soft cotton rag can work, but it does a much better job if it is dampened with a solvent, such as mineral spirits or paint thinner. Commercially made tack rags are sold as the ideal solution, but I don't buy that argument.

The quality of the cloth, and the sticky stuff that attracts the dust can vary widely. A good tack rag will pick up dust without leaving anything behind. A bad one can be stiff enough to cause scratches, or leave a residue that prevents the next coat of finish from adhering. **WM**

— Robert W. Lang



On flat surfaces, grain direction does not matter, but it is important to move at a right angle to the direction of your fingers. Going the same way can produce grooves in the surface.



Sanding sponges are an excellent balance of a flat surface that gives enough to gently handle corners and edges.



Sponges are also good for getting at both sides of an inside corner.



A nylon pad and a gentle touch can sand an outside corner without going too far.



Abranet is mesh, so dust has a place to go. If it clogs, it can be cleaned with a blast of air.

Reviving Techniques Forgotten (and Gross)

Hock up a loogie and start saving your earwax.

With a sound like a cat retching up a hairball, I reached deep inside myself to call forth enough spittle in my mouth to do the job.

I looked at the sharpening stone. I looked at my plane iron. Then I shook my head and deposited the contents of my mouth on the stone. Yes, this might be a little graphic for a family magazine, but it's all in the name of honest historical discovery, I assure you.

I spread the loogie on the stone and started to hone the plane iron, but not in the way that you think. Instead of planting the stone on the bench and holding the plane iron with two hands (or a honing guide), I did something you never see in woodworking magazines: I held the tool with my right hand, the stone with my left and rubbed them together.

At that moment I thought I had really gone too far with this experiment. After a dozen strokes, however, it didn't feel so weird and so I got brave enough to take a peek at the bevel of the tool.

It was surprisingly shiny and consistent – not at all what I expected from this 17th-century hotdogging sharpening technique.

You see, for the last year I've been reading and trying to update the first-ever woodworking book in English: Joseph Moxon's "Mechanick Exercises." I've read the section called "The Art of Joinery" more than a dozen times now, and I can tell you that it's like visiting another country.

Lots of things are familiar (like finding a Starbucks while visiting London), but plenty of techniques seem crude or just plain wrong (like eating at a Burger King on the Champs Elysées). Exhibit A of the weird is the sharpening instructions offered by Moxon, who was a printer and globe maker by profession, not a woodworker.

After my surprising success with this oddball method, I was emboldened to try some of the other things in the book.



Such as planing miters. This technique is a lot like the sharpening technique in that you hold the work in one hand and the tool in the other. Except for large pieces of work, Moxon instructs you not to clamp things in your workbench's vise. Instead, you hold your plane upside down in your left hand and thrust the miter over the tool's sole with your right.

Again, I didn't think I had the manual dexterity to pull this off. So I took a fairly soft wood (poplar) and marked and sawed a miter on the end with a carcass saw. I left a little bit of my knife line. Then I gave the technique a whirl.

Again, I was surprised. A well-sawn miter is fairly easy to true this way (with a little practice). I even checked my work with a miter square to confirm that I was indeed at 45°.

With other techniques I didn't have to overcome my fear, I instead had to overcome the 17th-century English. Moxon's instructions for mortising have you work from the ends of the mortise to the middle. But it was unclear (to me) at which end of the mortise you start. And this greatly affects how the chisel works because of the direction you are told to face the tool.

So I tried starting at the far end. No good. That mortise would never be clear of chips (good thing it was practice wood). The I reversed the order of my steps and everything fell into place. I made a tidy mortise in no time flat.

Score: Moxon, 3; Moderns, 0.

In addition to the practical advice, Moxon also sheds a little light on some of the practices that were common in English workshops, such as pouring low-alcohol beer into the hide glue to make it work better. Moxon says that's not a good idea so I'll skip that experiment, but there is one little trick I would like to try some day.

In Moxon's section on house carpentry, he discusses a prank that masters would play on their apprentices. The masters would coat nail heads with earwax so the apprentices' hammers would slip off the nails. I think this would be a hilarious practical joke to play on my shop mates (especially after they thought the spit on the sharpening stone was a joke).

But it's going to take me a long time to save enough earwax to coat the heads of a strip of 18-gauge pneumatic nails. **WM**

— Christopher Schwarz

Extras

“The secret to success is constancy to purpose.”

— Benjamin Disraeli (1804 - 1881)
British statesman and author

Visit the New & Improved Woodworking-Magazine.com

Woodworking-Magazine.com has been upgraded to include ... wait for it ... *Woodworking Magazine* articles!

In addition to an ever-growing database of articles from back issues of the magazine, you'll also find direct links to the newest additions to the editor's blog, CD compilations, books and more.

Plus, the new site is tied into our sister publication's site, PopularWoodworking.com, so you'll be able to easily find all the woodworking information and resources you need.



New! The First 8 Issues of *Woodworking Magazine* Now Available On CD

We sold out of our older CD, so we've revised the new printing to include issues 1-8! This easy-to-navigate and searchable CD collection gives you instant access to the first eight issues of *Woodworking Magazine* – including the first three issues that are sold out. Here's just a sample of what you'll find:



■ SolidWorks 3D

Drawings: You'll find “live model” drawings for many of the projects – drawings you can rotate in every direction to see all sides of the project in its assembled form. You can even pull individual parts off and rotate those around to look at all the joinery by zooming in and out. (The software to “read” these files is free – and there's a link to download it.)

■ **Help With Tools and Supplies:** Buying the tools we recommend or the supplies you need for a project is simple with the enhanced CD. Click on a supplies box and you'll be whisked to the company's web site where another couple clicks will let you purchase the items you need.

■ **Find the Information You Want:** All of the files are fully searchable so you can find that trick, technique or quote you're looking for.

■ **It's Great for the Shop:** You'll no longer have to worry about spilling varnish on your printed copy of the magazine – simply print out the drawings you need and head to the shop.

Order your copy of this exclusive disc now at woodworking-magazine.com or call 800-258-0929 (ask for disc #Z2983; just \$24.95, including s&h!).

Woodworking Magazine – The Hardbound Book (And a New One on the Way)

Although we offer digital versions of all issues of *Woodworking Magazine*, we have an affection for the printed word. So, we collected the first seven issues of the magazine and bound them into a book (now in its second printing).

Woodworking Magazine – The Book, Issues 1-7 is available on our web site (woodworking-magazine.com/books) for \$34.95 (includes domestic s&h). It's a perfect way to ensure your collection will last for years to come (and a great gift for fellow woodworkers).

And, we're working on a new book that will collect issues 8-12. Look for it on our web site in 2009!



IMPORTANT SAFETY NOTE

Safety is your responsibility. Manufacturers place safety devices on their equipment for a reason. In many photos you see in *Woodworking Magazine*, these have been removed to provide clarity. In some cases we'll use an awkward body position so you can better see what's being demonstrated. Don't copy us. Think about each procedure you're going to perform beforehand. Safety First!

CONTACT US



We welcome letters from readers with comments about this magazine, or about woodworking in general. We try to respond to all correspondence. To send us a letter:

- E-mail: letters@fwpubs.com
- Fax: 513-891-7196
- Mail carrier:
Letters • *Woodworking Magazine*
4700 E. Galbraith Road
Cincinnati, OH 45236

Number 12, Winter 2008. *Woodworking Magazine* (ISSN 1941-5834) is published 4 times a year in March, May, August and December by F+W Publications, Inc. Editorial offices are located at 4700 E. Galbraith Road, Cincinnati, Ohio 45236; tel.: 513-531-2222. Unsolicited manuscripts are not accepted. Subscription rates: A year's subscription (4 issues) is \$19.96 in the U.S., \$24.96 in Canada, and \$29.96 elsewhere. Produced and printed in the U.S.A.

UNDERSTANDING WOOD: FOUR STRUCTURE TYPES

ALL HARDWOODS HAVE VESSELS (LITTLE PIPELINES) THAT ARE USED IN SAP PRODUCTION. THE SIZE AND DISTRIBUTION OF THESE VESSELS VARY AMONG SPECIES; SOME ARE VISIBLE TO THE NAKED EYE. WHEN THE VESSELS ARE CUT ACROSS THE END GRAIN, THEY'RE OFTEN REFERRED TO AS PORES, THUS

HARDWOODS ARE KNOWN AS "POROUS WOODS" (SEE BELOW FOR FURTHER CLASSIFICATION). THE SIZE, NUMBER AND DISTRIBUTION OF THE VESSELS AFFECT THE APPEARANCE AND UNIFORMITY OF HARDNESS IN A PARTICULAR WOOD. SOFTWOODS, WHICH DON'T HAVE PORES, ARE KNOWN AS "NON-POROUS WOODS."

RING POROUS

IN SOME SPECIES (E.G. OAK AND ASH), THE LARGEST PORES ARE IN THE EARLYWOOD WHILE THOSE IN THE LATEWOOD ARE MORE EVENLY DISTRIBUTED AND UNIFORM IN SIZE. THESE WOODS TYPICALLY HAVE DISTINCT FIGURES AND PATTERNS, AND THE UNEVEN UPTAKE OF STAIN (THE LARGE PORES SOAK UP MORE COLOR) MAKE THE FIGURE MORE PRONOUNCED. THESE ARE ALSO KNOWN AS OPEN-GRAIN WOODS.

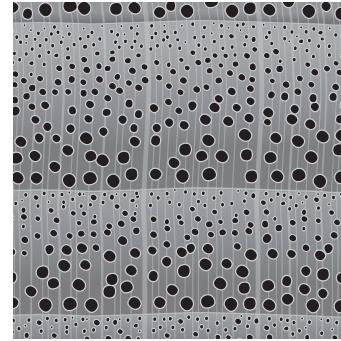
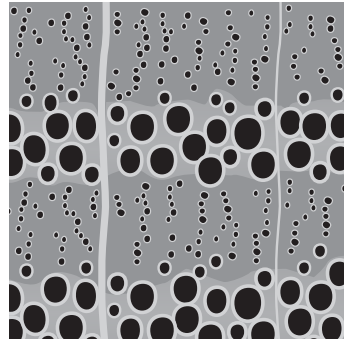

SEMI-RING POROUS OR SEMI-DIFFUSE POROUS

IN SOME SPECIES (E.G. BLACK WALNUT AND BUTTERNUT), PORES ARE LARGE IN THE EARLYWOOD AND SMALLER TOWARD THE LATEWOOD, BUT WITHOUT THE DISTINCT ZONING SEEN IN RING-POROUS WOODS. ALSO, SOME SPECIES THAT ARE USUALLY RING-POROUS (E.G. COTTONWOOD) OCCASIONALLY TEND TOWARD SEMI-RING POROUS.

KNOW THE PARTS OF SOFTWOOD AND HARDWOOD

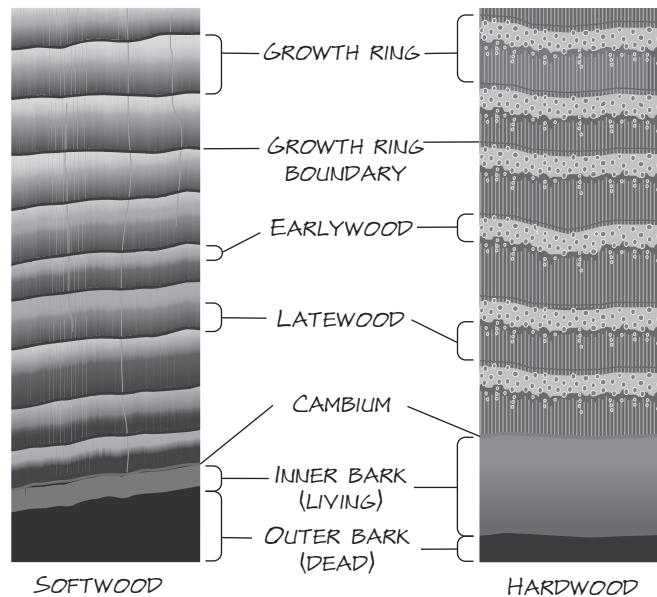

DIFFUSE POROUS

IN SOME SPECIES (E.G. MAPLE, CHERRY AND YELLOW POPLAR) THE PORES ARE DISTRIBUTED FAIRLY EVENLY ACROSS THE EARLYWOOD AND LATEWOOD. MOST DOMESTIC DIFFUSE-POROUS WOODS HAVE RELATIVELY SMALL-DIAMETER PORES, BUT SOME TROPICAL WOODS OF THIS TYPE (E.G. MAHOGANY) HAVE RATHER LARGE PORES. THESE WOODS USUALLY HAVE EVEN UPTAKE OF STAIN (THERE SEEMS TO BE NO SCIENTIFICALLY PROVEN EXPLANATION OF THE CAUSE OF BLOTCHING). THESE ARE ALSO KNOWN AS CLOSED-GRAIN WOODS.

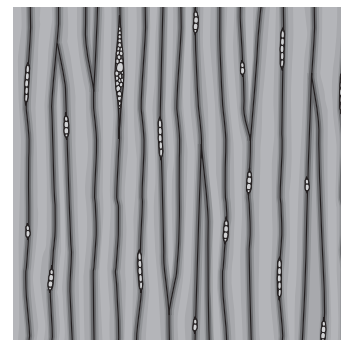
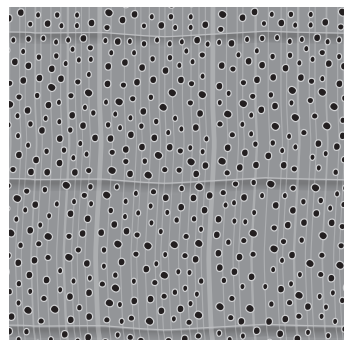

NON-POROUS

SOFTWOODS DON'T HAVE VESSEL CELLS (WATER IS CONDUCTED IN THE LIVING TREE IN TRACHEID CELLS). DIFFERENT SOFTWOODS HAVE DIFFERENT GROWTH-RING CHARACTERISTICS HOWEVER. IN WHITE PINE, THE RINGS ARE NON-DISTINCT, AND STAIN UPTAKE IS FAIRLY EVEN, AS IN DIFFUSE POROUS WOODS. IN YELLOW PINE, WHERE THE RINGS ARE CLEARLY VISIBLE, STAIN UPTAKE IN EARLYWOOD IS MORE PRONOUNCED THAN IN LATEWOOD, AS IN RING-POROUS WOODS.