

**NO ADS!** 100% WOODWORKING

# Woodsmith®

www.woodsmith.com

**1 HOUR**  
**Workshop:**  
**10 Easy-To-Build Bench Accessories**

**4 Best Bits** for  
**Router Table Joinery**

low-cost

**Classic Bookcase**

**build 1, 2, or 3**

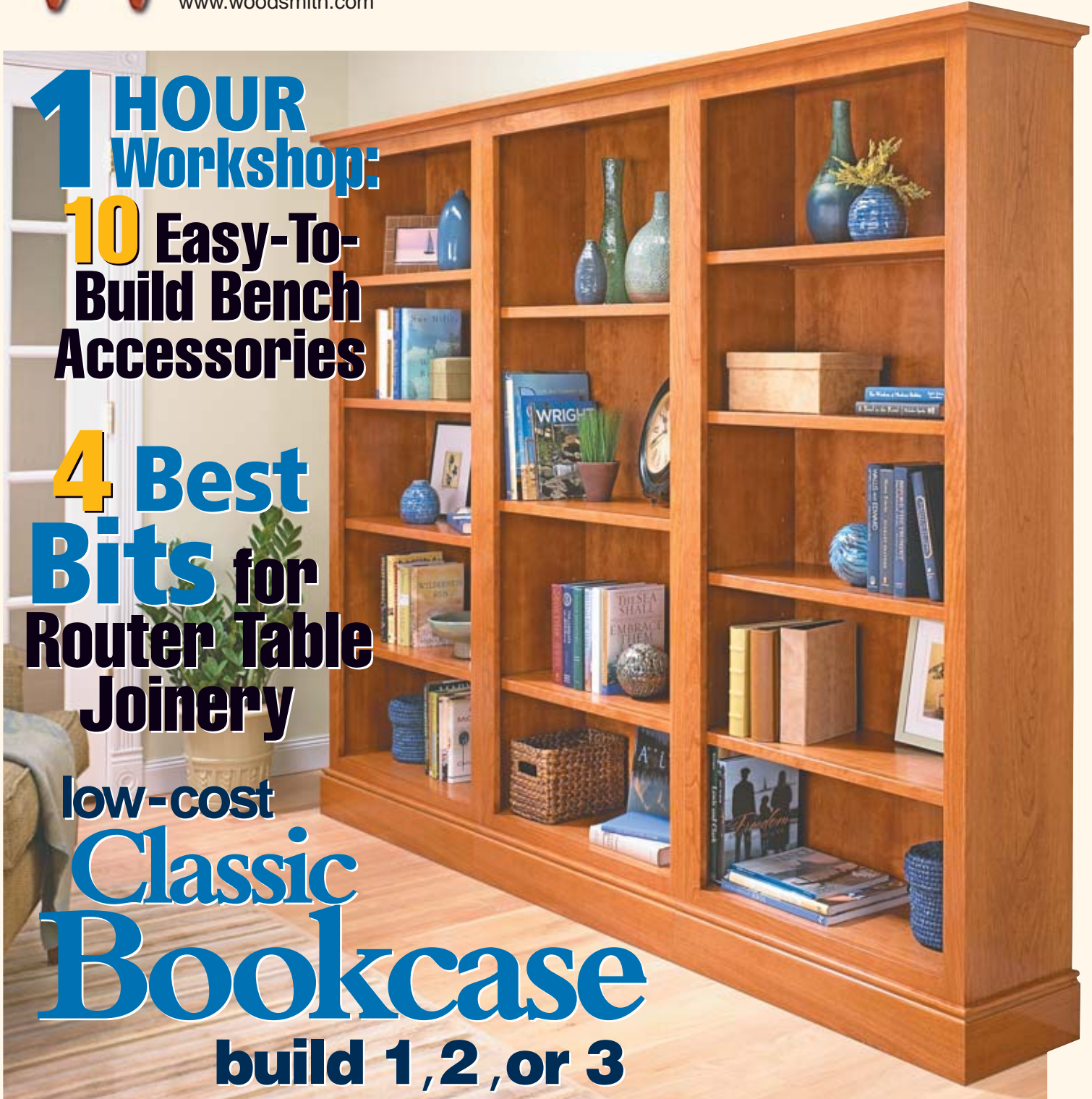

# Table of Contents

## departments

from our readers

**Tips & Techniques** . . . . . 4

all about

**Strong & Sturdy Shelving** . . . . . 8

Learn the secrets to building sag-free shelves.

**ONLINE EXTRA**  
video workshop

tools of the trade

**Router Table Joinery** . . . . . 10

We tried out some joinery bits with great results.

techniques from our shop

**5 Repairs for Major Mistakes** . . . . . 12

Find out the steps you can take to repair five common woodworking mishaps.

jigs and fixtures

**Using Pocket Hole Joinery** . . . . . 14

Take your pocket hole jig beyond face frames to a few applications you may not have considered.

tips from our shop

**Shop Notebook** . . . . . 22

small shop solutions

**One-Hour Workshop** . . . . . 30

Work faster and more accurately at your workbench with 10 easy-to-build accessories.

working with tools

**5 Tools That Will Change Your Work** . . 44

Find out which tools can really make a big difference in your shop.

finishing room

**Never-Fail Finish** . . . . . 46

Nothing beats an oil and wax finish for looks and ease of application.

in the mailbox

**Q & A** . . . . . 48

hardware and supplies

**Sources** . . . . . 49

Tile-Top Table page 16



Tall Bookcase page 24

weekend project

ONLINE EXTRA  
video workshop

**Tile-Top Craftsman Table . . . . . 16**

This small table is the perfect project to try your hand at mortise and tenon joinery.

DESIGNER'S NOTEBOOK

designer series project

**Tall Bookcase . . . . . 24**

This easy-to-build bookcase has everything you want — sturdy construction, adjustable shelves, modular design, and classic molding.

DESIGNER'S NOTEBOOK

heirloom project

**Classic Oak Tool Cabinet . . . . . 34**

What more could you ask for? Quartersawn oak, simple joinery, fine details, and lots of storage.

**Fine Tool Chest . . . . . 42**

Build the perfect companion to the tool cabinet. It shares all the same details — just smaller.

details of craftsmanship

**Built to Last . . . . . 50**

Learn what it takes to build long-lasting projects using solid wood.



Tool Cabinet page 34

editor's note

Sawdust

Welcome to *Woodsmith!* Do you want to learn all the tips and tricks that can make you a better woodworker? Would you like to build practical projects that not only look good, but give you an opportunity to try your hand at interesting techniques as well? If this all sounds good, then I think *Woodsmith* is the right magazine for you. But you don't have to take my word for it, just check out some of the things this issue has to offer.

For starters, there are three great practical, versatile projects in this issue — a tile-top table, a tall bookcase, and a classic oak tool cabinet. And you'll find a range of projects like this in each issue of *Woodsmith* — everything from quick, weekend projects to functional storage projects to fine, heirloom furniture projects.

But *Woodsmith* is more than just great woodworking plans. You'll also find helpful, time-saving tips and skill-building ideas that you can use in your shop. Each issue contains over ten different departments that cover virtually every aspect of woodworking, from tools and shops to joinery techniques and finishing. For example, take a look at the one-hour workshop article on page 30. There you'll find ten workbench accessories, any one of which you can build in an hour and put right to use in your shop.

I hope you enjoy this complimentary issue of *Woodsmith* and find it a useful and practical addition to your shop.

Terry

ONLINE EXTRA  
video workshop

Woodsmith  
GO ONLINE  
EXTRAS

These two symbols let you know there's more information online at [www.Woodsmith.com](http://www.Woodsmith.com). There you'll see step-by-step videos, technique and project animation, bonus cutting diagrams, and a lot more.

# Tips & Techniques

## Flip-Up Outfeed Extension Table

In my small, basement shop, there just isn't enough room for a permanent outfeed table for my cabinet saw. I needed a table that I could set up and take down quickly, but was still strong and sturdy.

I found the solution while roaming around in my local home improvement center — the folding shelf brackets you see in the photo at left.

As the drawings below show, I attached the vertical arms of the brackets onto mounting plates so the table top would clear the saw's fence rail when it was in either the up or down positions. I did the same thing with the horizontal arms to raise the outfeed table level with my saw table. To keep the table flat and to add



▶ This outfeed extension table swings into action when it's needed and safely tucks out of the way when it's not.

strength, I added braces underneath the outfeed top and then mounted the table perfectly level with the saw table. Finally, I cut grooves in the table to line up with the miter slots in my saw table.

It works very nicely, and now I have the outfeed table I've always wanted — one that's there when I need it and gone when I don't.

Malcolm Robb  
Brantford, Ontario, Canada

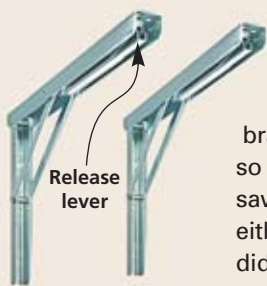

▲ These shelf brackets lock in the up position and are released by pressing the levers inside the horizontal arms of the brackets.

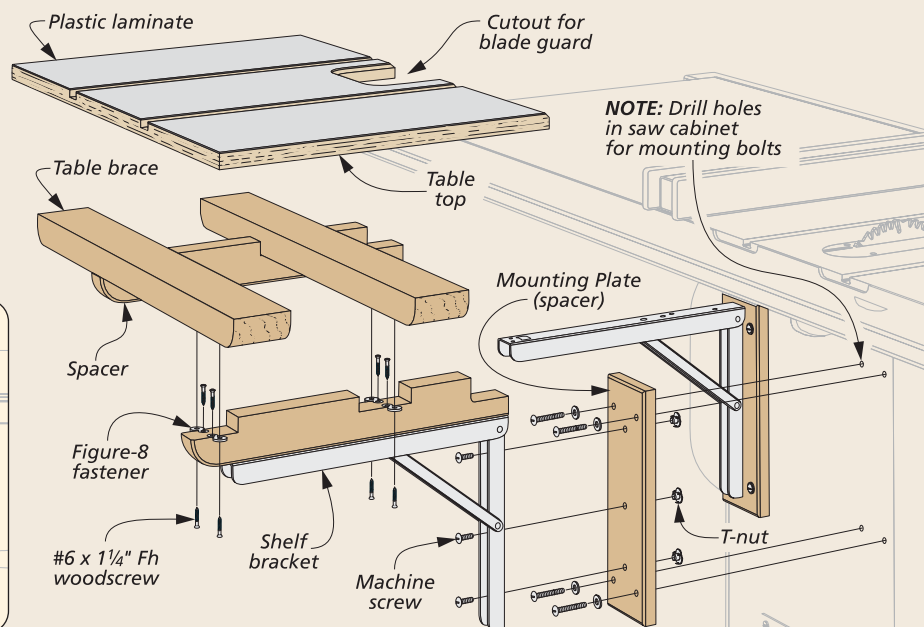
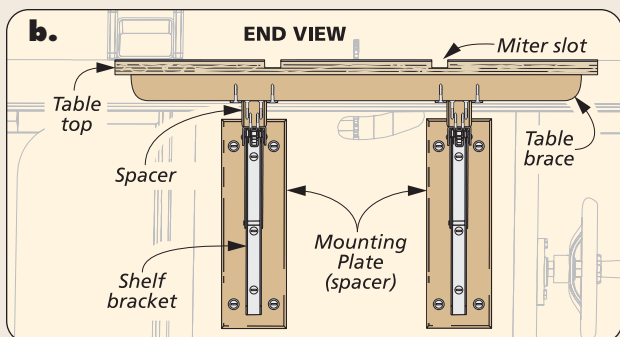
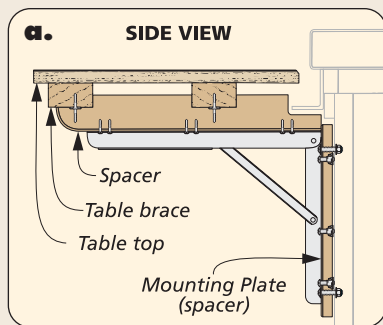

Woodsmith® (ISSN 0164-4114) is published bimonthly (Feb., Apr., June, Aug., Oct., Dec.) by August Home Publishing Company, 2200 Grand Ave, Des Moines, IA 50312.

Woodsmith® is a registered trademark of August Home Publishing. Copyright© 2005 August Home Publishing Company. All rights reserved. Subscriptions: Single copy: \$4.95. One year subscription (6 issues), \$24.95. (Canada/International add \$10 per year, U.S. funds.)

Canadian Subscriptions: Canada Post Agreement No. 40038201. Send change of address information to PO Box 881, Station Main, Markham, ON L3P 8M6. Canada BN 84597 5473 RT

Postmaster: Send change of address to Woodsmith, Box 37112, Boone, IA 50037-2112.

Subscription Questions? Write to Woodsmith, P.O. Box 842, Des Moines, IA 50304 or call 1-800-333-5075, 8:00 am to 5:00 pm, Central Time, weekdays. Or send an email to: [orders@woodsmith.com](mailto:orders@woodsmith.com)

Email: [woodsmith@woodsmith.com](mailto:woodsmith@woodsmith.com)

World Wide Web: <http://www.Woodsmith.com>

[www.Woodsmith.com](http://www.Woodsmith.com)

## ONLINE SUBSCRIBER SERVICES

- **ACCESS** your account
- **CHECK** on a subscription payment
- **TELL US** if you've missed an issue
- **CHANGE** your mailing or e-mail address
- **RENEW** your subscription
- **PAY** your bill

Click on "Subscriber Services" in the list on the left side of our home page. Menus and forms will take you through any of the account-maintenance services you need.

## HOW TO REACH US:

FOR SUBSCRIPTIONS, ADDRESS CHANGES OR QUESTIONS, WRITE OR CALL:

**Customer Service**  
2200 Grand Ave., Des Moines, IA 50312  
**800-333-5075** 8 a.m. to 5 p.m. CT

OR VISIT OUR WEB SITE:  
[www.Woodsmith.com](http://www.Woodsmith.com)

**AUGUST HOME**  
PUBLISHING COMPANY

Printed in U.S.A.

## Planer Sled

Planing a flat face on a wide, warped board can be a real challenge. The problem is that the uneven surface of the board causes it to rock back and forth on the planer bed like a see-saw. To solve this problem, I built a planer sled.

A pair of cleats on the end register the workpiece. Then to get one face flat, I added a row of cut-off woodscrews along each side, as shown in the drawing. By raising the screws, you can support the workpiece (detail 'a'). When the top face is flat, remove the sled, flip the board over and finish planing the other side.

Brent Robinson  
St. Paul, Minnesota

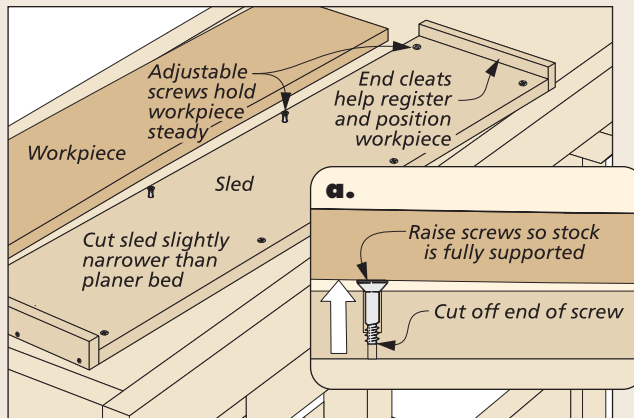

## Handscrew Support

Working with long stock and wide panels can be a real hassle. Not only are they difficult to move around, but they're hard to support while working on them. This is especially true when the piece has to be supported on edge. For that, I usually clamp the piece in the face vise of my workbench.

However, that means the other end is unsupported for planing, sanding, or cutting mortises.

While wrestling with another large workpiece, I came up with a pretty simple solution that uses a traditional woodworking tool — a wood handscrew. As you can see in the photo at right, all I did was clamp the handscrew at the end of the workpiece and

rest it on the top of the bench. It worked perfectly. Now if the workpiece still moves around as you're working, you can clamp the handscrew to the bench with another handscrew or other clamp.

Scott Wallace  
Goshen, Massachusetts

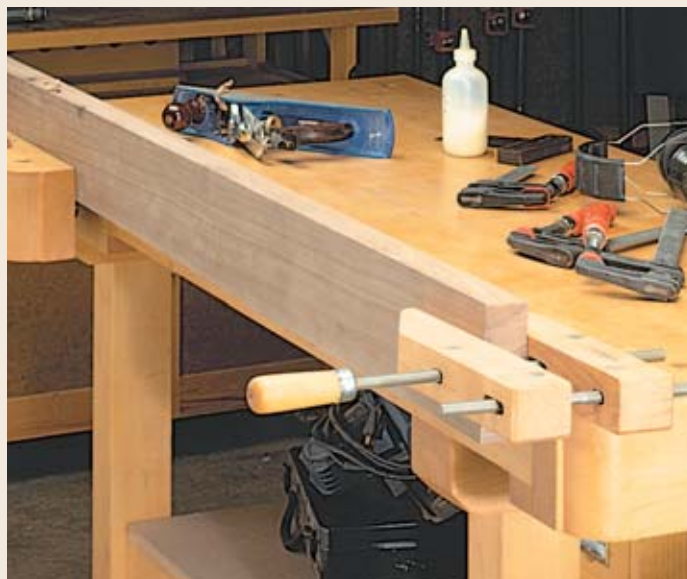

## Band Saw Blade Tension Lever

Setting the tension on my band saw blade was time-consuming. I needed a way to release the tension and then quickly return the tension to the proper setting the next time I used the saw. One day, it struck me that I could make a simple lever to quickly release the tension (see photo at right).

First, I replaced the band saw's original "knuckle-busting" tension rod with one long enough to clear the saw's housing. That will make fine-tuning the tension easier.

For the lever to clear the tension gauge, I built a riser and slid it down the rod. The riser sits on the guides on either side of the gauge.

To make the lever, I used a 2' piece of hardwood and tapered it to fit my hand better. I rounded the front and bottom corners to make the lever easier to raise and lower.

Next, I attached a spacer block to the lever. This block will hold the lever in the "up" position to maintain the proper blade tension when I'm using my band saw. But you'll need to attach the block to the lever at this point so the hole for the rod is drilled at the correct



angle. Then, I took the lever (with the spacer attached) to my drill press and drilled the hole to accommodate the rod.

I counterbored the hole to hold a washer and lock nuts at the same angle as well.

Then I added the lever and the hardware (see detail 'a'). To tension the blade, I simply lift the lever and pivot it toward the saw until the spacer rests on the

riser. To release the tension, all I have to do is just lift and pivot the lever away from the saw. You can still fine-tune the tension if you need to by adjusting the longer tension rod and knob.

Bill Esposito  
Rindge, New Hampshire

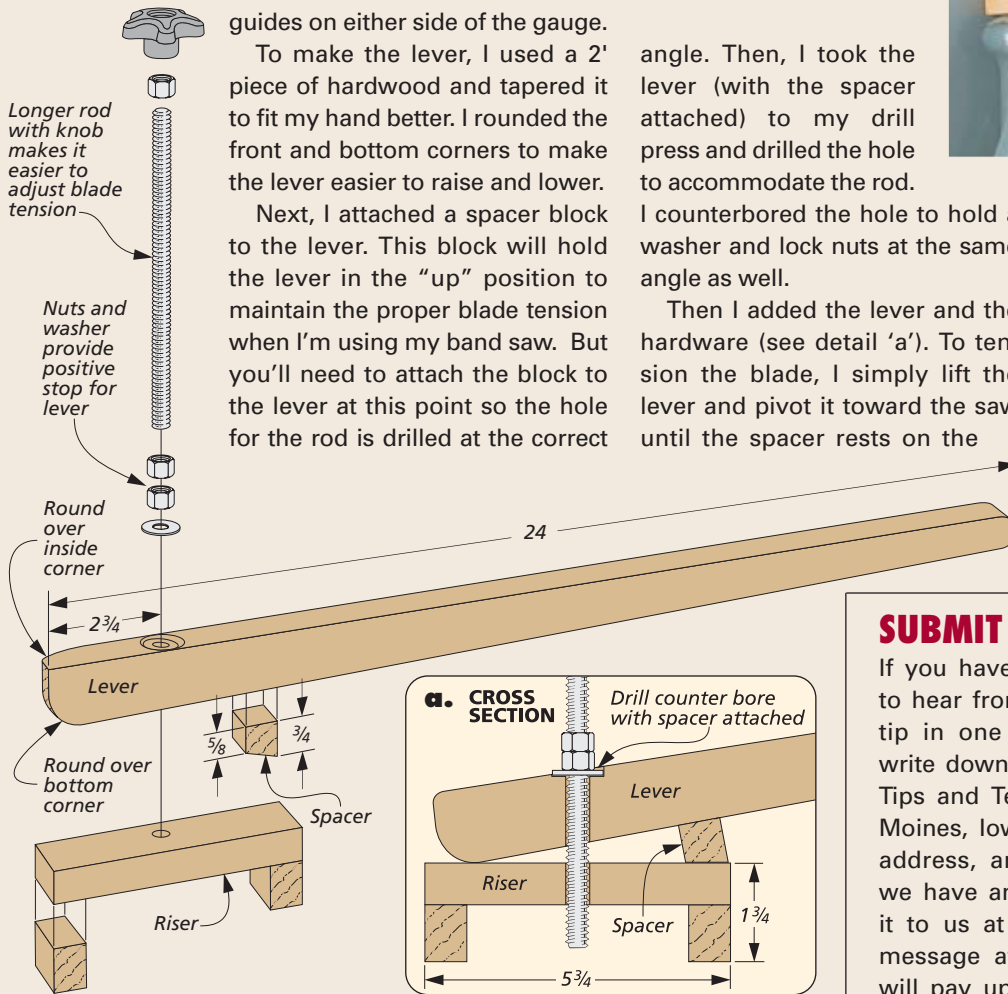

## SUBMIT YOUR TIPS

If you have an original shop tip, we would like to hear from you and consider publishing your tip in one or more of our publications. Just write down your tip and mail it to: *Woodsmith*, Tips and Techniques, 2200 Grand Avenue, Des Moines, Iowa 50312. Please include your name, address, and daytime phone number in case we have any questions. If you would like, FAX it to us at 515-282-6741 or send us an email message at: [woodsmith@woodsmith.com](mailto:woodsmith@woodsmith.com). We will pay up to \$200 if we publish your tip.

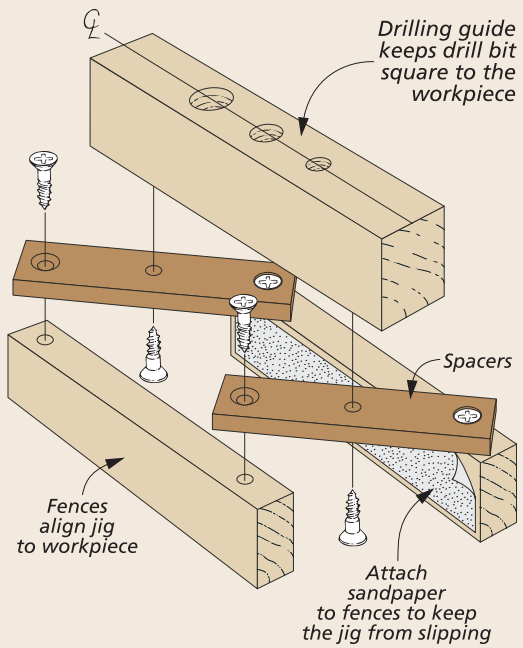

## Doweling Jig

Drilling centered, consistent holes is crucial for dowel joints. While you can purchase a doweling jig, I made my own (photo at right).

The drilling guide is just a piece of hardwood with a few centered holes that match common dowel sizes. A pair of 1/2"-thick fences are attached to a pair of pivoting spacers.

To use the jig, slip it over the end or edge of a workpiece. Then pivot the spacers until the fences are flat against the workpiece. A few strips of self-adhesive sandpaper keeps the jig from slipping.



Jared Huber  
Appleton, Wisconsin

## Quick Tips

### DUCT TAPE SANDPAPER BACKER

It's easy for the sandpaper on my sanding block to get snagged and torn on a workpiece. Besides being a pain, it's a waste of materials. But I've come up with a simple way to make it last a little longer. I apply a layer of duct tape to the back for added reinforcement.

Bill Reiman  
Brooklyn, New York

### SHARPENING SURFACE

I sharpen my tools with sandpaper. But to get the best results, I need a flat surface. So I bought a granite reference plate used by machinists. It's inexpensive and heavy so it won't get pushed around from the sharpening action.

Charles Jarman  
El Cajon, California

### PLAYING CARD PROTECTORS

To keep the workpiece from being marred by the collar of the countersink bit when drilling holes, I punch holes in a playing card with a paper punch. Then when you drill a hole in which the drill collar comes in contact with the workpiece, slip the playing card over the hole and the playing card protects the workpiece.

Len Urban  
Rancho Mirage, California

## Pipe Clamp Pads



Pipe clamps are a great way to assemble a project. The problem is the jaws can damage the wood. So I came up with a simple solution — wood pads that fit over the jaws of my pipe clamps and protect the project (see photo).

The wood pads slide over the 3/4" pipe, remain in place at all times, and can serve as clamp stands when needed.

The 3/4"-thick pads start out as 2" x 3 1/4" blocks. To allow the pipe to pass through the block, I drilled a 1 1/8"-dia. hole at one end.

After rounding off the sharp edges at the hole end, all that's left is to slide the pads in place and you're ready to go to work.

Vince Franzik  
Chesapeake, Virginia

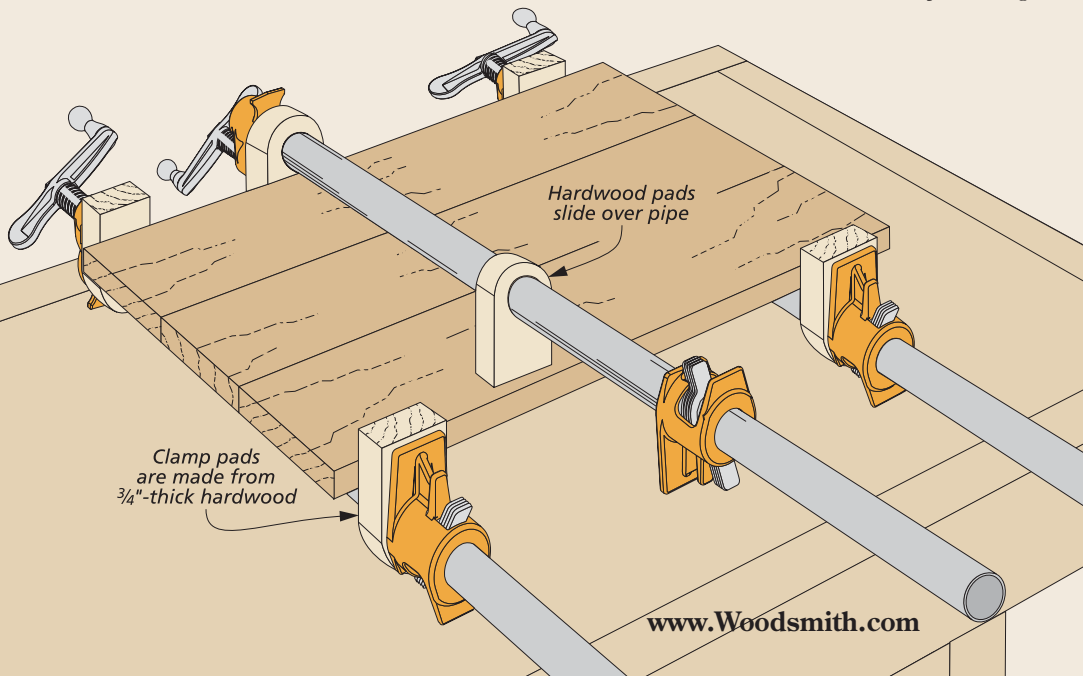



solutions for sagging shelves

# Strong & Sturdy Shelving

Build plywood shelves that not only look great but will stand up to heavy-duty loads for the long haul — without sagging.

Most of the storage and cabinet projects I build have at least a couple shelves. The shelves are used to store everything from odds and ends to heavy books and electronics. And nothing's more disappointing than seeing a shelf sag as soon as you start loading it up.

The amazing thing is how little sag it takes before you begin to notice it. All it takes is a sag of about  $\frac{1}{32}$ " for each foot of shelf length before it stands out like a sore thumb.

So any time you build a project with shelves, it's important to keep strength in mind. And one of the

first things to consider is the material you use to build the shelves.

**MATERIALS.** For most of my projects, I'll either use solid wood or plywood over particle board or medium-density fiberboard (MDF). And nine times out of ten, plywood will be my first choice.

Now don't get me wrong. There's nothing wrong with solid wood shelves. They look great and they're strong. But using only solid wood can be expensive. Plus, solid wood expands and contracts — just another thing to think about when designing a project.

**PLYWOOD SHELVES.** To avoid these problems, I turn to plywood. But like other materials, even plywood has its limitations. You can find out how much a plywood shelf will sag using an interesting program, called *The Sagulator* (see Plywood Shelving

## Plywood Shelving Fast Facts:

- Always consider the expected load for a shelf when designing a project
- The total load, how it's arranged, and how the shelf is reinforced all affect the strength of a shelf
- You'll start to notice sag once it measures  $\frac{1}{32}$ " for each foot of shelf length
- The maximum shelf length to consider without any reinforcement is about 30"
- The main ways to increase the strength of a shelf:
  - Widening (deepening) the shelf
  - Shortening the shelf
  - Adding a hardwood strip on edge (roughly triples the strength)
  - Doubling the thickness (increases shelf strength by four)
- You can calculate the approximate sag of a shelf by use an online program: *The Sagulator* at [www.woodbin.com](http://www.woodbin.com)



Fast Facts at left). This program considers the material, size and loading of a shelf and gives you a rough idea of how much a shelf will sag. So what if you find your shelf isn't up to the task?

**STRENGTHENING A SHELF.** One of the simplest ways to minimize sag is to make shorter shelves or make them deeper. But that's not usually an option since it affects the overall design and look of a project that I may not want to change.

**GIVING PLYWOOD AN EDGE.** Instead, I look for ways to give my plywood a better "edge." What do I mean by that? Well, I almost always have to cover up the edge of plywood with thin strips of hardwood to hide the plys. You can see what I'm talking about in the top photo at right.

But hardwood edging doesn't always have to be thin and narrow. With a little thought and extra work, you can make that edging strip do so much more — it can really add strength to the shelf.

To do this, but still maintain the look of a "thin" shelf, I'll often use a wider hardwood strip. Gluing on a wider strip can be a challenge. So when I do this, I like to

use a tongue and groove joint, like you see in the second photo from the top. The tongue and groove provides a mechanical "lock," so it's easy to keep the strip aligned with the face of the shelf. For many shelves, this simple addition may be all it takes to eliminate any noticeable sag.

**TURN IT ON EDGE.** But the best way to ensure a strong shelf is to simply take that strip, widen it just a bit, and turn it on edge, like you see in the main photo on the opposite page. Now there are a couple ways you can add a strip on edge (see lower two photos at right).

The first way is to cut a rabbet in the hardwood strip and glue it in place. The other is to join the edging to the shelf with a tongue and groove joint. Both ways will triple the strength of a shelf. Even though the tongue and groove joint is a little more work, it ensures the edging and shelf are aligned perfectly without much effort.

**HEAVY-DUTY DESIGNS.** There are times when strength is what matters most. To see a couple different ways to make a really strong shelf, check out the box below. **W**

## Heavy Loads: Beefing it Up



**Super-Strong Shelves.** For very heavy loads, like encyclopedias and electronics, you might want to consider the shelves shown above. They add more strength than what's shown in the margin.

Adding a pair of strips under the shelf along with an edging strip (left) helps reduce the sag to a fourth of a plywood shelf the same size. Want a simpler look with less joinery? You can get the same strength by doubling the thickness of the shelf and then gluing on a wide edging strip (right).

## How-To: Add Strength

**GOOD**



**Simple Edging.** Although it adds a small amount of strength, the main purpose of a strip of thin edging is to cover up the plywood edges.

**BETTER**



**Wide Hardwood Strip.** To add strength, but still maintain a "thin" edge, use a tongue and groove joint to add a wide hardwood strip to the shelf.

**BEST**



**Turn it on Edge.** Taking a wide hardwood strip and turning it on edge (top photo) significantly strengthens the shelf without requiring a lot of additional work. Adding a tongue and groove joint (bottom photo) adds just as much strength, but the joinery makes aligning the edging and shelf a snap.

# 4 great bits for Router Table Joinery

A router table can be a pretty handy tool when it comes to cutting joinery. Dadoes, rabbets, grooves, and other simple cuts can easily be made using standard straight bits.

But in the past few years, router bit manufacturers have come out with several new bits that open up some really interesting joinery possibilities. So I decided to pick up several of these bits for a trial run. And what I found in my quick test was pretty impressive.

You can view a video of these router bits in use by going to: [www.Woodsmith.com](http://www.Woodsmith.com)

**ONLINE EXTRA**  
video workshop



The four bits that I looked at all allow you to quickly and accurately cut joints on the router table that would be tricky or next to impossible to do otherwise. The key is that each "single" bit cuts both halves of a locking joint.

These bits are all fairly big, so you'll need a router with a 1/2" collet and enough horsepower to handle them. And I got the best results by slowing them down with a variable speed router. (For sources, see page 49.)

## Lock Miter Bit

I've seen lock miter bits in catalogs and on store shelves for a few years and the idea intrigued me. Just *cutting* an accurate miter on the table saw is no easy job. But then you still have to figure out how to glue and clamp the joint afterwards. Well, here's a router bit that can easily take the hassle out of both these operations.



▲ A lock miter bit can take a lot of the hassle out of cutting and assembling miter joints.



If you take a look at the photo below, you'll see how it works. The bit will cut a 45° miter on the ends or edges of boards to be joined together. At the same time it cuts matching tongues that "lock" the two halves of the joint together during assembly. This makes gluing and clamping the joint a snap.

As you can see in the drawings below and the photo above, the

matching miter joint is made by running one piece horizontally and the other piece vertically.

To do this accurately and with better control, I cut an L-shaped plywood guide piece and then clamped the workpieces to it. (You can see it behind the workpiece in the photo above.) This both backs up the cut and steadies the workpiece as you make the cut.

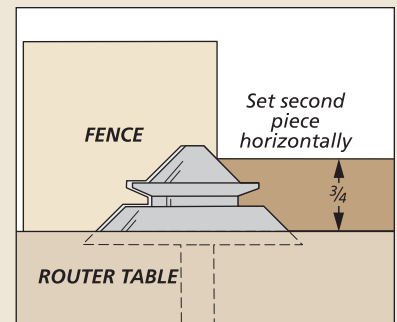
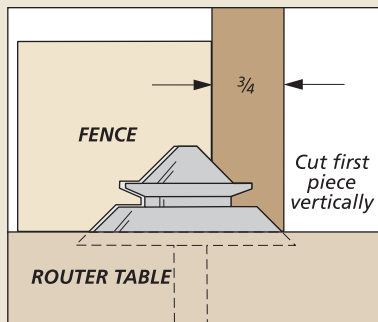

## 2 Box Joint Bit

This new box joint bit (made by *Amana*) gets my award for inventiveness. It will cut small box joints in material up to 1/2" thick and from 3/4" to 1 1/2" in height with a sin-



gle pass. And as the photo at left shows, the result is an easy-to-assemble, tight-fitting joint. But maybe best of all, I found it a real treat to use.

The drawing at right shows how it works. I cut one corner at a time by flipping one of the workpieces upside down and then clamping both workpieces to a backup block. Then with a single pass

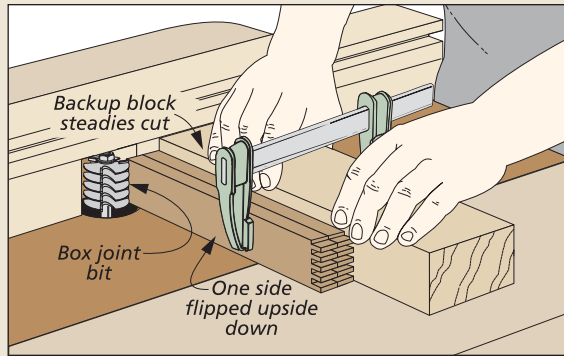

across the bit, both halves of the joint are cut simultaneously. After the cut, just flip one piece over and the joint will fit together like a hand in a glove.



▲ With this clever bit you can cut box joints for small drawers and boxes.

## 3 Glue Joint Bit

Edge joining boards is a pretty common operation in any shop and this handy glue joint bit is designed to make the process a little easier and the joint stronger.

The glue joint created by this bit offers a couple of advantages over a simple butt joint. As you can see in the first photo at right, the shape of the joint greatly increases the amount of gluing surface and gives you a much stronger joint. Second, the joint becomes self aligning so

achieving a smooth, flush surface is almost foolproof (second photo below). Anyone who has had to glue up large panels can certainly appreciate this feature.



A match is made by adjusting the bit to the proper height and then routing one piece face up and the second piece face down. It worked great for me.



▲ A glue joint bit will create a strong, self-aligning joint.

## 4 Finger Joint Bit

At one time or another, just about every woodworker has wished for a board stretcher. Well, the adjustable finger joint bit in the photo at right might be the next best thing. With this bit, you can rout tightly interlocking fingers on the ends of boards that allow you to join them together. The fingers create

both a mechanical lock and a large amount of gluing surface. And as you can see, end-to-end joints are a reality. (Check out the cherry/walnut board in the left photo).

There are just a few simple tricks to getting good results with this bit. First, it needs to be adjusted to the thickness of your stock. This just involves adding or removing cutters and shims (right photo).

Next, in order for the two faces of the workpieces to end up flush, the bit has to be set to the correct height in the router table (drawing at right). This requires a test cut or two. Then, using a backup piece to give me a little better control, I routed one piece face up and one face down. Once glued, the joint is surprisingly strong. **W**

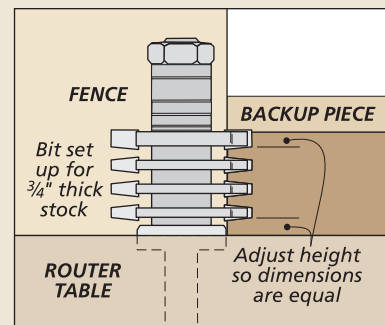

▲ This adjustable finger joint bit will cut a tight-fitting interlocking joint in stock from 7/16" to 1 3/8" thick.

## 5 simple repairs for Major Mistakes



▶ Router chipout like this can be easily fixed by removing the damaged area and gluing in a filler strip.

Mistakes happen. And when they do, you have to deal with them. Here's a look at some quick and easy fixes for five common woodworking goofs.

### 1 Router Chipout

There are few things more frustrating than routing a profile on the edge of a workpiece only to have a sliver of wood blow out. Fortunately, there's an easy fix.

All you have to do is rout a rabbet along the edge of the profile to

removed the damaged area (Step 1). Then glue a slightly oversized filler strip of matching wood into the rabbet (Step 2). After planing or sanding the filler strip flush with your workpiece, you can rout a new profile along the edge.

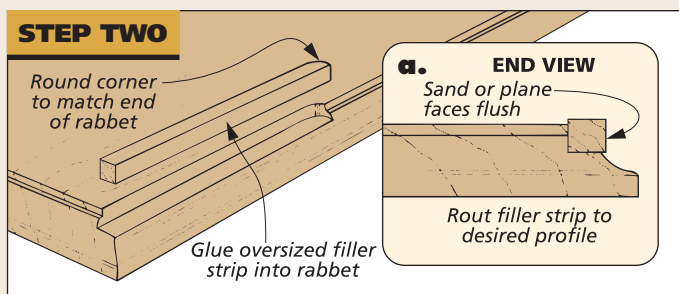
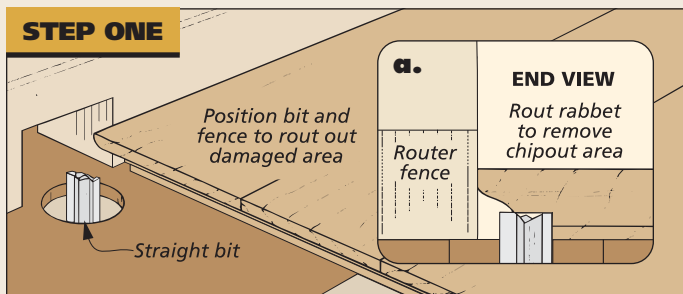

### 2 Moving a Hole

Drilling pilot holes for hinges is not one of my favorite chores. No matter how hard I try, it seems like there's always at least one hole where the drill bit drifts off its mark. When this hap-

pens, the best solution I've found is to "move" the hole.

This might sound impossible, but if you take a look at the drawings below, you'll see how easy it really is. All you have to do is drill out the

offending hole with a larger-diameter drill bit. (A Forstner bit works best.) Then glue a face grain plug into this hole. Finally, lay out the correct location for the pilot hole and re-drill the hole.

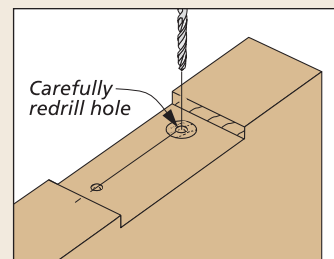
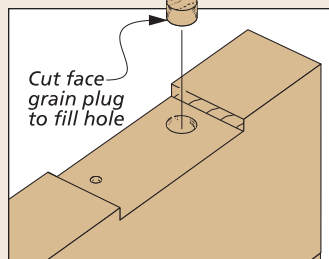
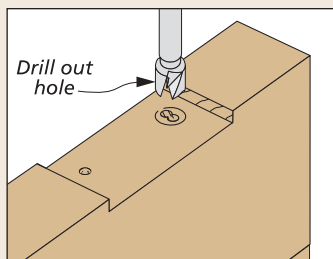
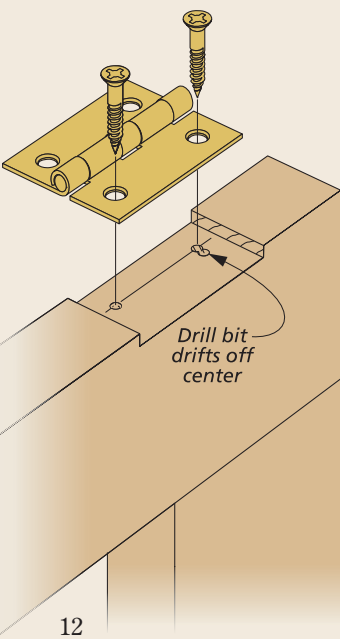

### 3 Misplaced Mortise

There are few mistakes in woodworking that can make you feel as foolish as making a mortise in the wrong spot on a workpiece. If you have extra stock, it's probably easier to make a new part. But if you're working on something more substantial (like a heavy table leg) making a new piece may not be an option.

In this case, the next best solution is to "patch" the mortise. The process is really pretty straightforward. Start by cutting a wood plug to fit in the mortise. After gluing it into the mortise, trim  $\frac{1}{8}$ " off the face of the workpiece. (The face with the mortise.)

Next, cut a facing out of some  $\frac{1}{8}$ "-thick stock and glue it to the workpiece. (Try to match the facing to the color and grain of the workpiece as close as possible.) After trimming the facing flush with the workpiece, you can lay out the mortise in the correct location.

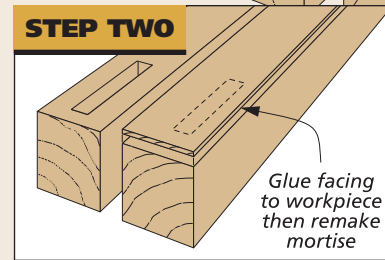
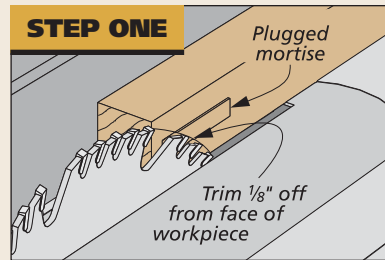

▲ Plugging a misplaced mortise allows you to salvage a workpiece.

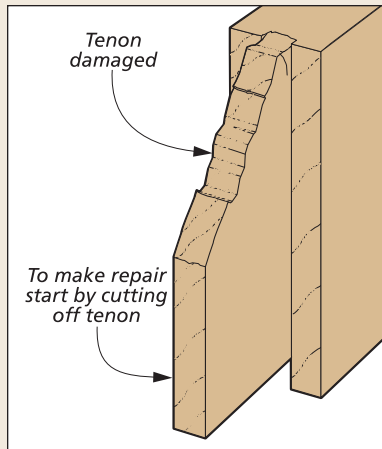
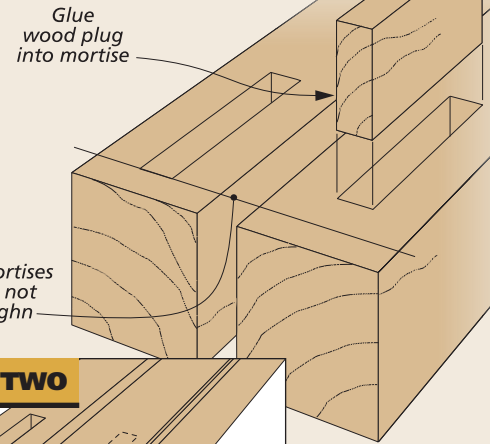

**Half Lap.** You can repair a damaged tenon by trimming it off and gluing on a new piece of wood to the end of the workpiece.

### 4 Damaged Tenon

It's not only mortises that can give you problems. Sometimes, a tenon can snap off while you are making a dry run to test the fit. Here again, making an entirely new replacement piece may not always be the best option. In this case, you can recut the tenon by gluing on a new "end" to the workpiece.

To do this, start by trimming off the damaged tenon at the shoulder. Then cut a slot in the end of the workpiece as shown in the drawing at right. (This slot should be at least 1" deep.)

Next, cut a tongue on the end of a scrap piece of stock to fit in the slot in the workpiece. After gluing the scrap piece into the slot, you can go ahead and recut the tenon.

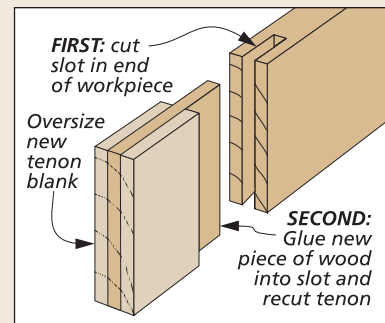

### 5 Open Miters

Miter joints are notoriously tricky when it comes to getting a tight fit without any gaps. This next tip has saved me on more than one occasion.

If you have a miter joint that is open just slightly, try "burnishing" it closed. All you have to do is take a burnisher (I use the round shank of a screwdriver) and run it across the edge of the open miter (from bottom to top), as in the drawing at right.

The burnisher closes up the joint by "rolling over" the mitered ends

of the workpieces. Once the project is finished, you'll probably be the only one that will know there was ever a problem to begin with.

Note: This tip works well on miters that are off just slightly ( $\frac{1}{32}$ " or so). But if you have a miter with a larger gap, you're better off cutting through the joint and re-gluing the pieces again. **W**

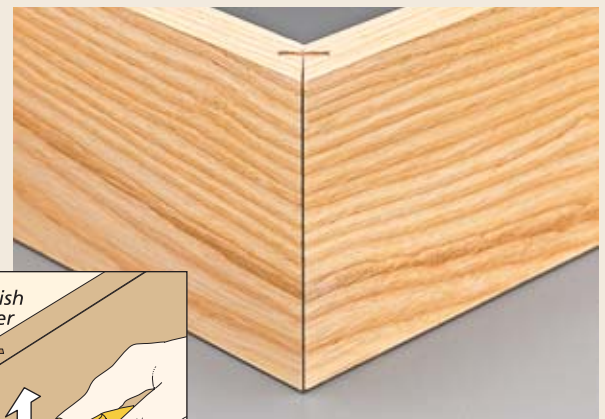
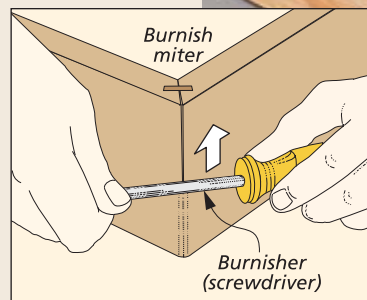

▲ Open miters like this are a common problem. Burnishing the miter closes up the gap and makes the joint nearly invisible.



## jigs & fixtures

# putting Pocket Hole Joinery to work for you

When you think of pocket hole joinery you usually think of mass-produced kitchen cabinets and furniture. The kind that are easy to build and fast to assemble.

But this type of joinery is not just for making face frames for cabinets. And you don't have to work in a cabinet shop to use it. Because it's so quick and easy (see box below), I find myself drilling pocket holes more and more.

Pocket hole joinery works well for almost any joint. Here are a few ways I've found they work great.

**CORNER JOINTS.** Pocket holes are great for joining aprons to table legs. They're faster and easier than cutting mortise and tenon joints. And with a little of reinforcement from a corner block, they're every bit as strong. You can see what I mean in the photo above and in the one at the lower left on page 15.

Just use your jig to drill two pocket holes at the end of each apron. Then choose the right pocket screw for the job (see the hardware box on the next page) and secure the apron to the leg.

## How-To: Pocket Hole Basics

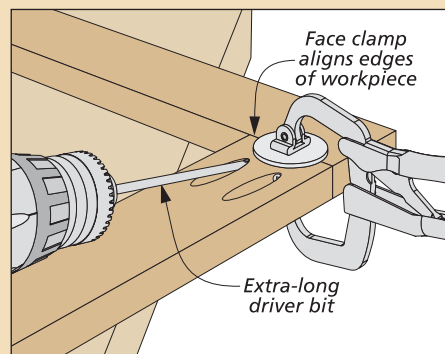
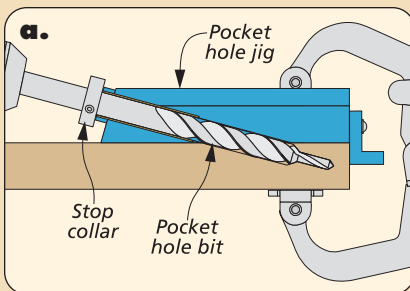
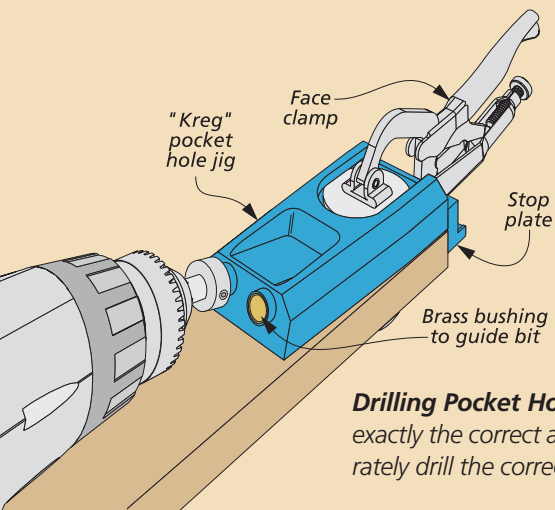

**Drilling Pocket Holes.** The pocket hole jig guides the drill bit at exactly the correct angle. The stop collar can easily be set to accurately drill the correct depth hole in various thicknesses of wood.

**Inserting Pocket Hole Screws.** After the hole has been drilled, it's easy to drive the self-tapping pocket hole screws in place.

**JOINT REINFORCEMENT.** As I mentioned, it doesn't hurt to reinforce table legs with a corner block as shown in the photo on the opposite page. It's attached with three pocket hole screws. One screw is driven into each apron and one into the leg. This adds even more strength and stability to the legs at each of the corners.

**MITER JOINTS.** Pocket hole joinery can come in real handy when you need to pull a miter joint together. To hold a miter joint tight, drill a pair of pocket holes opposite and perpendicular to the joint line, as shown in the photo at the right. A face clamp holds the joint flush while you drive in the screws.

**ATTACH A TABLE TOP.** You don't usually think of using pocket screws for attaching the top of a table. But it's as easy as drilling holes into the aprons (see photo below) and then driving screws into the table top. Using the jig and the correct screw size insures that the screws don't come through the top of the table.



▲ Two pocket holes square to the miter joint and opposite one another allows pocket hole screws to secure the miter joint. A face frame clamp makes it easy to hold the joint in position while the screws are inserted.

If you're concerned about wood movement, drill the pilot holes in the edge a little oversized. Then after driving the screw, back it out one quarter turn so it can move as temperature or humidity changes.

**SHELF BANDING.** Adding shelf banding to plywood with pocket holes is another alternative to splines or biscuit joinery. Simply drill pocket holes along the edge of the top like you see in the photo at the right below. Then drive in the pocket

hole screws to fasten the shelf banding piece securely in place.

The right angle clamp shown in the photo helps out here. One arm fits into the pocket hole and the flat surface on the other arm holds the the edging in place so you can drive in the pocket screws.

As you can see, pocket hole joinery has many uses. The joints are strong, and when the holes are hidden the joint looks great. You'll be surprised at how easy it is to do. **W**



▲ Attach a table top by drilling pocket holes and driving screws. Drilling the pilot hole a bit larger and backing the screw out slightly, allows for wood movement.



▲ Pocket holes are a great way to secure edging to a shelf. A right-angle clamp holds the edging to the shelf while the screws are driven in place.

## Hardware: Choose the Best Pocket Screw



▲ **Thread Type.** Fine threads (top) are used for hardwood and course threads (bottom) are for softwoods.



▲ **Screw Length.** Choosing the right screw length depends on the thickness of the workpiece you are using.



▲ **Head Style.** Use washer head screws (top) for plywood and pine. Pan head screws (bottom) are for hardwoods.



## Weekend Project

# tile-top Craftsman Table

A simple design with no-nonsense mortise and tenon joinery makes this table an irresistible project.

You say you've never tried to cut a mortise and tenon joint before? Well this attractive Craftsman-style table might be a great place to start.

Like most Craftsman-style pieces, this table sticks to the basics. It's mostly just straight lines and straightforward joinery. Mortise and tenon joinery is one of the cornerstones of woodworking. And once you get a good feel for it,

you're well on your way to building this classic little table.

Let's break it down for a quick look at what's going on. You start with four, square legs and then join the upper and lower rails with "mitered-end" mortise and tenon joints. Next, you add some vertical slats on three sides. They're joined to the rails with a shallow mortise and tenon. And then to top it off,

you build a mortise and tenon frame into which is set a ceramic tile panel. You get the picture?

The best news is that the joinery here isn't the least bit difficult. Whether you decide to cut your mortises by hand, the way I like to do it, or maybe invest in a mortiser like those discussed on page 44, you'll get some good practice with a great end result.



# making the LEGS

I like to start work on a table by making the legs, and if you take a look at the drawing at right, you'll see that this is a straightforward task.

**GETTING STARTED.** The first thing you'll need to do is to cut four identical legs (A) to size from 1 3/4"-thick stock at the table saw. When this job is complete, it's a good idea to take time to pair up the legs for the best look (front and back) and then mark them clearly on the top.

**THE MORTISES.** The box below shows you the steps to hand mortising. With the legs cut to size, you begin by laying out the four mortises on each leg. I like to "gang them up" and mark them all at once as shown below.

With the layout completed, the next step is to gather up the four legs and take them to the drill press. Here, I drill a series of overlapping holes to remove most of the waste from the mortises.

Take a look at detail 'a' and you'll see how the two adjacent mortises meet in the leg. What this means is that when drilling the second mortise into the previously

drilled mortise, you'll need to go slow to avoid splintering.

After roughing out the mortises at the drill press, I moved to the workbench to complete the job. Using a sharp chisel, I pared away the peaks between the holes and squared the ends of the mortise.

**EASE THE EDGES.** To wrap up the work on the legs, I took them to the router table. I didn't want to leave sharp edges that could be easily damaged, so I installed a 1/8" round-over bit to ease all four long edges and the bottom edges as shown in details 'b' and 'c.'

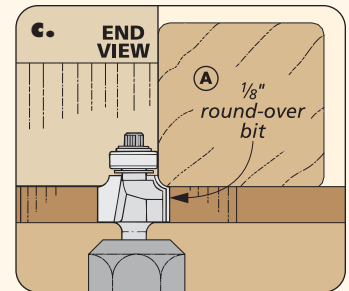
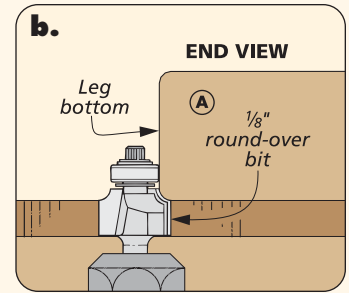
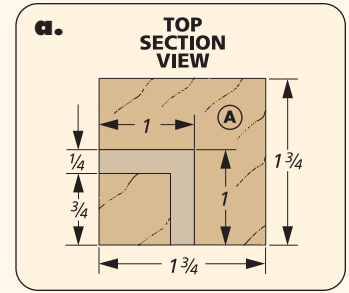
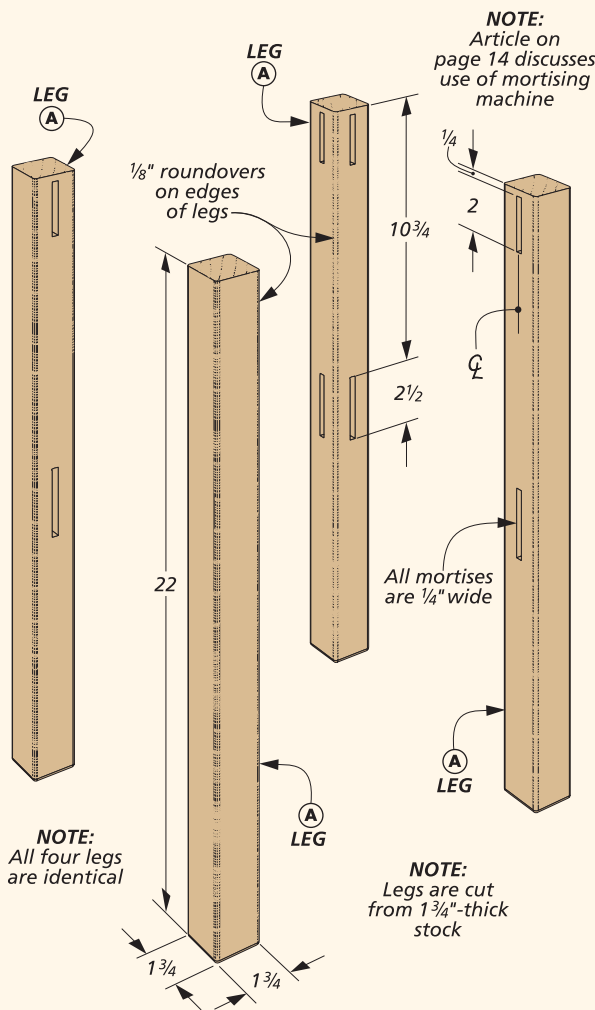

## How-To: Make a Mortise

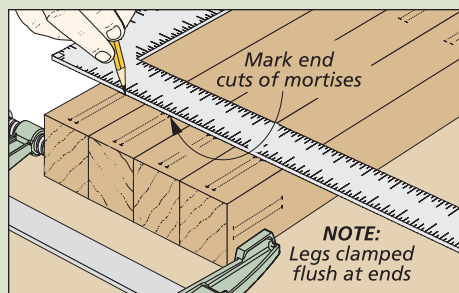

**Lay Out the Mortises.** Since the mortises are positioned identically in each leg, just mark one leg and then use a square as a guide to transfer the marks to the other legs.

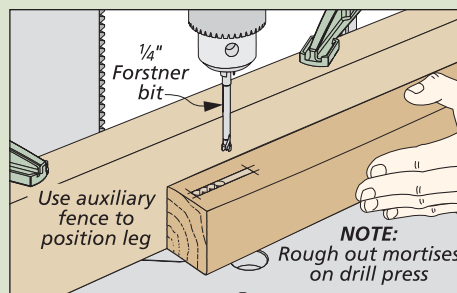

**Drill Out the Waste.** Once the mortises are laid out on the legs, you can take them to the drill press. Drilling a series of overlapping holes will remove most of the waste.

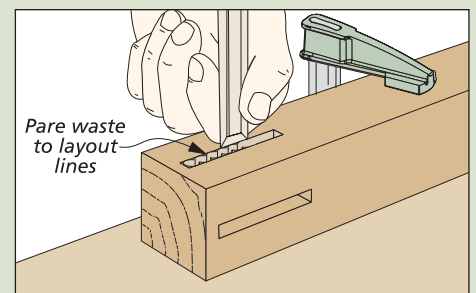

**Back to the Bench.** The final step is to clean up the mortise with a chisel. Smooth the cheeks by paring back the peaks left by the drill press and then square the ends.

# fitting the RAILS

With the four legs ready and waiting, I turned next to making the upper and lower rails that connect them.

**TENONS FIRST.** Once you've cut the four, identical upper rails (B) and the four, identical lower rails (C) to size from  $\frac{3}{4}$ "-thick stock, you can install a dado blade in the table saw. Use it to cut the tenons on the ends of the rails (detail 'a').

When each tenon is a snug fit in its mortise, switch back to a standard blade to miter the ends of the tenons (detail 'b'). A small gap between the tenons will leave space for glue and ensure that the tenons seat fully in the mortises.

**A FEW MORE MORTISES.** At this point the leg to rail joinery is done. But later, you're going to add vertical slats between the upper and lower rails on three sides of the base. This requires cutting a few more shallow mortises. You can do this using the same method used for the leg mortises. Both the upper and lower rails on the two sides and the back have identically-spaced mortises — but not the two front rails.

**THE SHELF DADO.** You'll also be adding a shelf that's captured by dadoes in the lower rails of the base. So cutting these dadoes is the

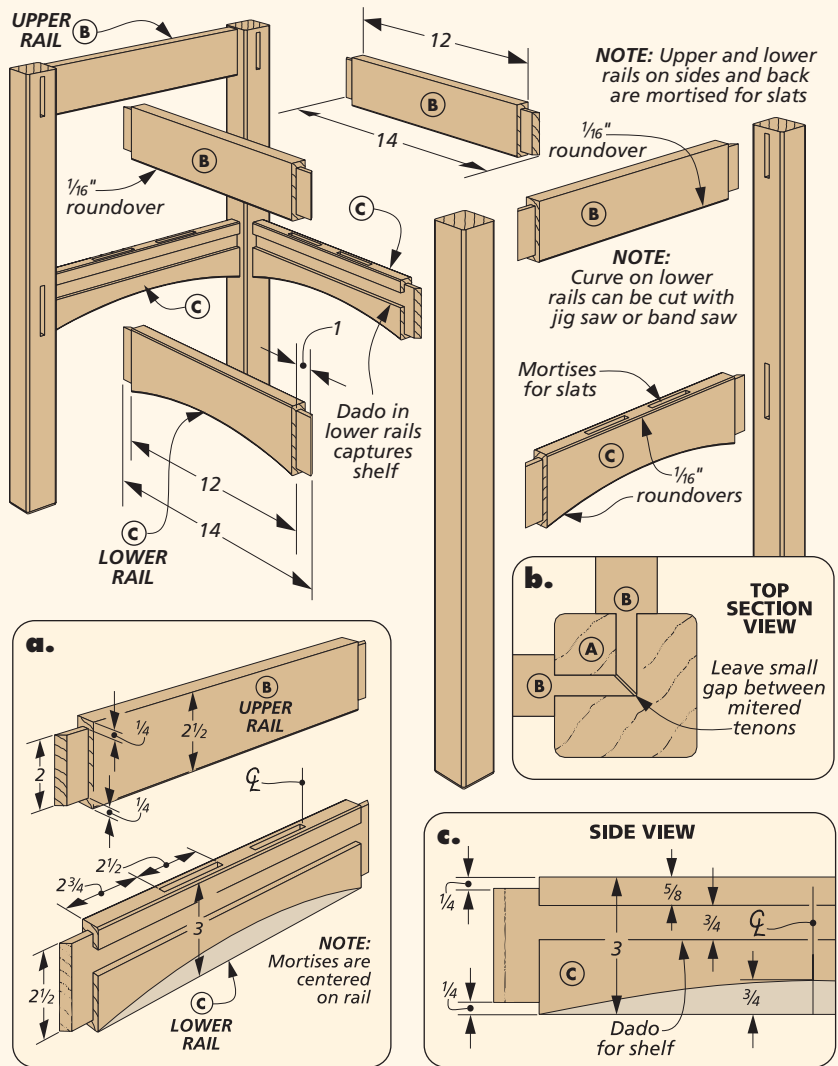

next task. The drawing below shows you what you need to do.

**GENTLE CURVE.** The shallow curve on the lower rails is a classic Craftsman-style touch. Detail 'c' gives the dimensions you need and the photo below shows a clever way to draw consistent curves.

**KNOCK OFF THE EDGES.** After cutting the lower rails to shape at the band saw, I sanded the edges smooth and then took all the rails to the router table. There I used a  $\frac{1}{16}$ " round-over bit to ease all of the sharp long edges (but not the tops of the upper rails).



▲ A notched scrap of hardboard and a short length of string is all you need to lay out a smooth, consistent curve. A series of knots tied in one end of the string allows you to easily adjust the amount of "bow."

## How-To: Shelf Dadoes

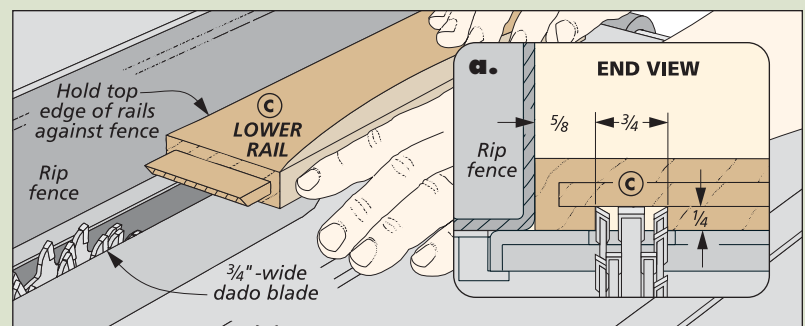

**Cutting the Dadoes.** The dadoes in the lower rails that hold the shelf can be cut quickly with a  $\frac{3}{4}$ "-wide dado blade installed in the table saw. Clearly mark the top edge of each rail and then hold that edge against the fence. Gradually raise the blade to sneak up on the final depth of the cut.

# completing the BASE

At this point you might be getting a little anxious to see the fruits of your labor take shape. Well, once you've made the vertical slats and the solid wood shelf, you can start to put all of the pieces together.

**THE SLATS.** First, I tackled the slats. You'll need to cut 6 vertical slats (D) to size from  $\frac{3}{8}$ "-thick stock. The slats have a short tenon cut onto each end to fit the mortises in the rails (detail 'b'). Once again, a dado blade is the tool for the job.

For short tenons like these, I use a  $\frac{3}{4}$ "-wide dado blade buried in an auxiliary rip fence. You want to end up with a snug-fitting tenon and a slat that fits tightly between the rails. So slowly sneak up on the length and the width of the tenons by adjusting the rip fence and gradually raising the blade.

Then, just as before, you can soften all the long edges of the slats with a  $\frac{1}{16}$ " roundover.

**MAKE THE SHELF.** The final part to the base is the shelf and it won't take long to complete. First, glue up the shelf (E) from  $\frac{3}{4}$ "-thick stock. And when the glue is dry, cut it to size and sand it smooth.

Now in order for the shelf to fit around the legs, it needs a square notch in all four corners as shown

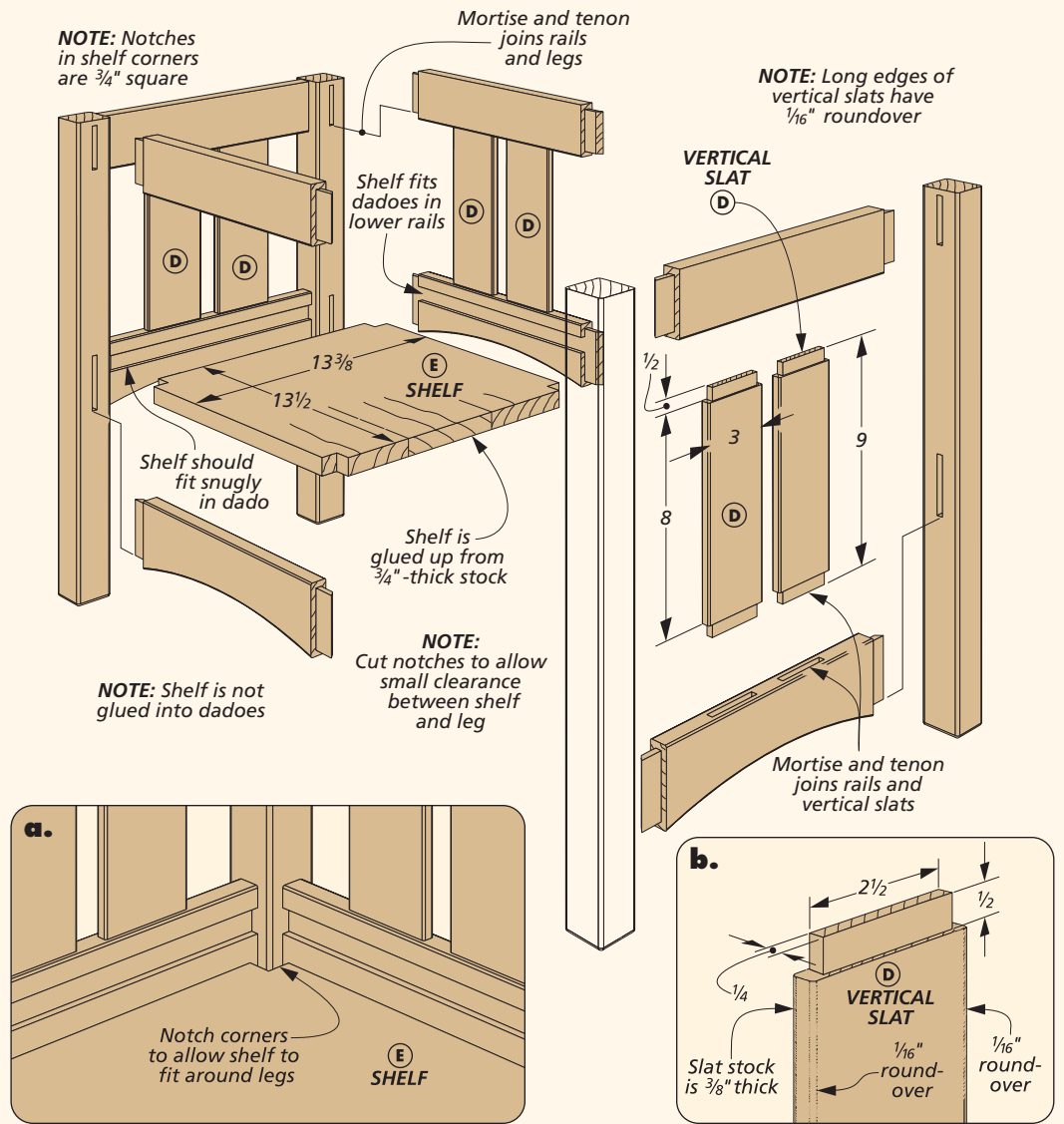

in detail 'a.' I completed this job quickly at the band saw. Don't worry about getting a tight fit around the legs. The shelf will fit snugly in the dados but needs to "float" freely. And a bit of clearance

around the legs will allow it to expand and contract easily.

Finally it's time to begin the assembly. For this I took a slow, step-by-step approach as described in the box below.

## Shop Tips: A Step-by-Step Assembly

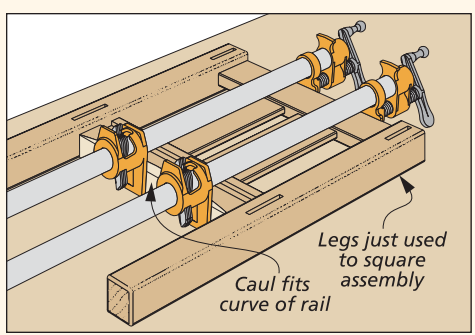

**Slats to Rails.** The first step is to glue up the three rail and slat assemblies. The legs are just used to square the assembly.

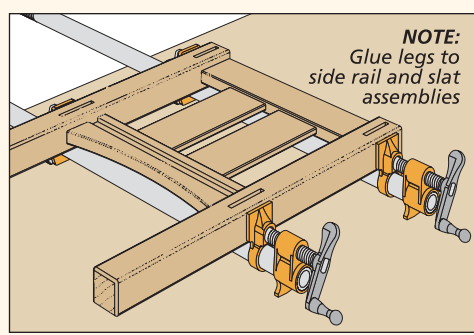

**Rails to Legs.** Once the rail and slat sections are assembled, the two side leg and rail assemblies can be glued together.

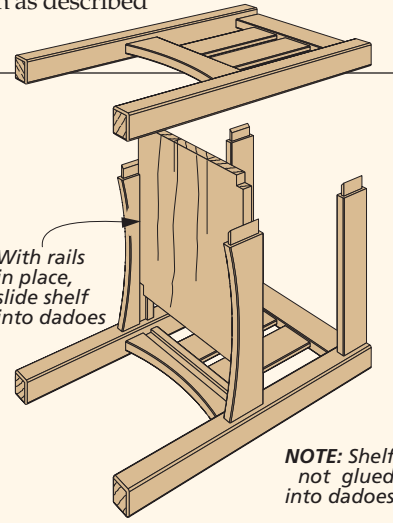

**Complete the Job.** Finally add the back rail section, the front rails, and the shelf. But don't glue the shelf into the dados.

# building the TOP

All the table lacks now is a top. And as you can see in the photo at left, the top for this table is not your standard, everyday, glued-up slab table top. The inlaid tile center adds a bit of a wrinkle to the construction, but the good news is it's not the least bit difficult and it looks great.

**THE FRAME.** The solid frame that surrounds the tile is just more of what you've done before — mortise and tenon.

The two long rails are mortised to accept the tenons of the two short rails. It's pretty simple. I got started by cutting the two *long top rails* (F) and the two *short top rails* (G) to size from 1"-thick stock. Detail 'a' shows what you need to accomplish in the next step. Begin by cutting a mortise in the long rails. Then cut matching tenons on the short rails. Once the joinery is complete, you can glue the frame pieces together.

**ROUND THE EDGES.** Once the frame is assembled, take it to the router table to soften the top and bottom edges with a  $\frac{1}{8}$ " roundover.

**ADDING THE PANEL.** Next you need to add a center panel on which to set the tile (How-To below). This requires rabbeting the lower, inside

Ceramic tiles inlaid into top

**NOTE:** Rails of top frame are joined with mortises and tenons

**NOTE:** Top rails are cut from 1"-thick stock

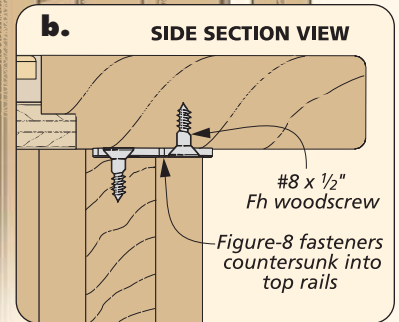
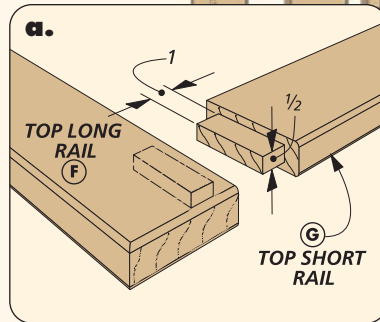
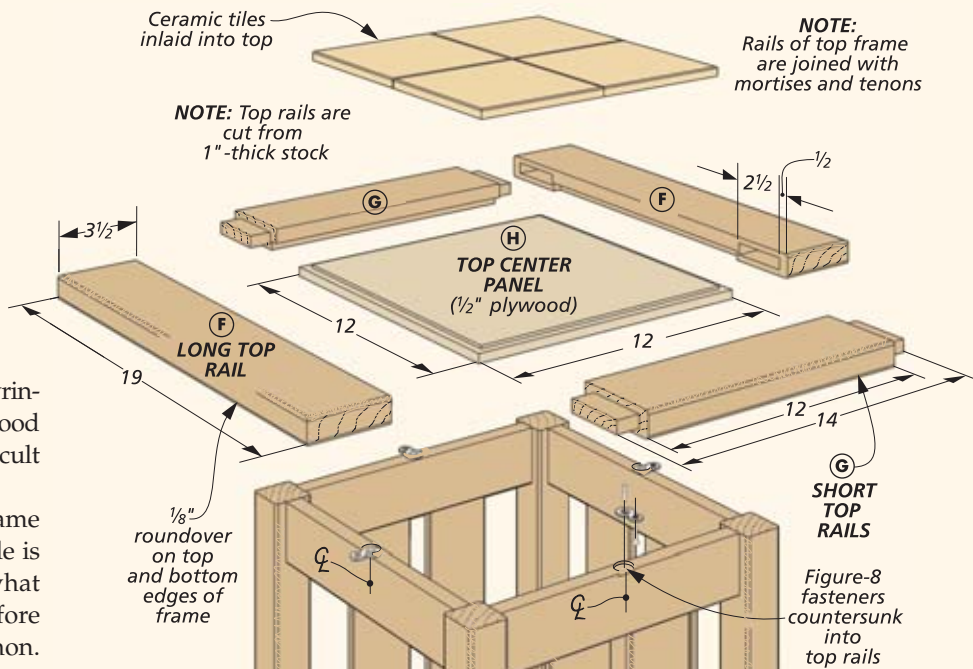

edge of the frame to accept the plywood *top center panel* (H). But there's a little more to the process that needs some explanation.

In short, when you set the tile, you want it to sit flush with the surrounding frame. I used four standard-sized ( $\frac{5}{8}$ "-square) tiles but the catch is that different

brands and styles of tile can vary in thickness. This means you need to custom-fit the panel so that the recess matches the thickness of the tile you choose. This just involves cutting a second rabbet on the plywood panel. If you just follow the step-by-step below, you shouldn't have any problems.

## How-To: Fitting the Center Panel

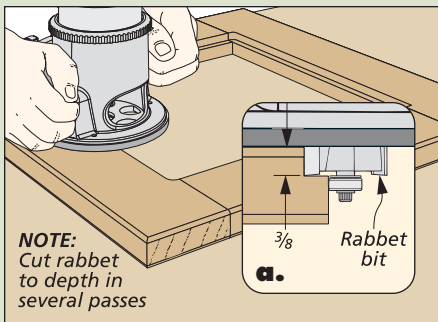

**Rabbet the Frame.** Get started by using a hand-held router with a rabbeting bit installed to cut a  $\frac{3}{8}$ " x  $\frac{3}{8}$ " rabbet around the bottom, inside edge of the frame.

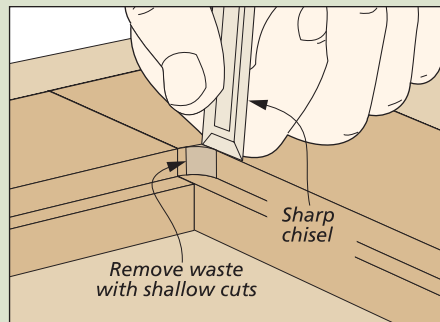

**Squaring Up the Corners.** Next, I set down the router and picked up a sharp chisel to carefully square the rounded corners left by the rabbeting bit.

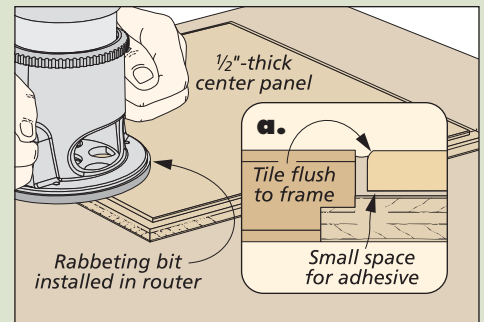

**Rabbet Panel.** After sizing a panel to fit the frame, adjust its height by rabbeting the top edge. You want the "tile" recess to match the tile thickness plus space for adhesive.

**ATTACH THE TOP.** Once you've glued the panel in place, the top can be attached to the table base. The metal "figure-8" fasteners that I used made this an easy job (left drawing). One fastener counter-sunk into the center of each top rail, as shown in detail 'b,' will hold the top tightly to the base.

### TILE SETTING

Before getting started on the tile, I went ahead and applied my finish.

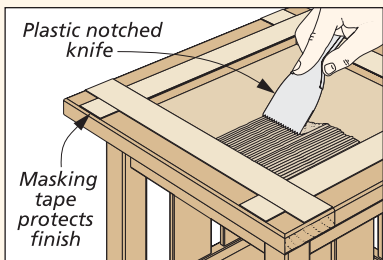

**Spread Adhesive.** First, tape off the frame. Then use a small, notched knife to spread the tile adhesive.

This way the wood is sealed from any stray adhesive or grout and I won't have to worry about keeping the stain and finish off of the tile and grout later on. Then to protect the finish, I carefully taped off the frame area around the center panel.

Setting the tile in the top isn't a difficult job, it just takes some basic know-how. The technique I used is fairly traditional, but also pretty easy. The boxes below give you the basic step-by-step approach. **IV**

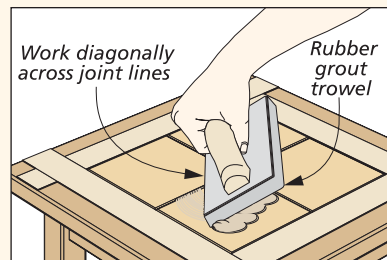

**Grouting.** Once the tile is set, mix a small batch of grout and work it into the joints with a grout trowel.

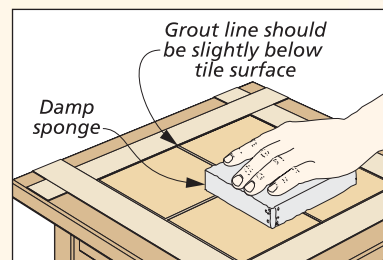

**Clean the Surface.** Finally, use a damp sponge to clean the excess grout from the joints and surface.



You can simplify the tiling process a bit by picking up a tube of pre-mixed grout. ►

### ONLINE EXTRA video workshop

To see a step-by-step video of how the Tile-Top table is built, go to: [www.Woodsmith.com](http://www.Woodsmith.com)

## DESIGNER'S NOTEBOOK

### same table Larger Size

The simple design of this table allows you to easily modify the size and create a table with maybe a different purpose, but an equally attractive appearance. If you take a look at the drawing at right, you'll see that all I did was make the square footprint of the table slightly larger. Instead of two vertical slats between the rails the table now has three. All of the joinery and construction techniques stay exactly the same.

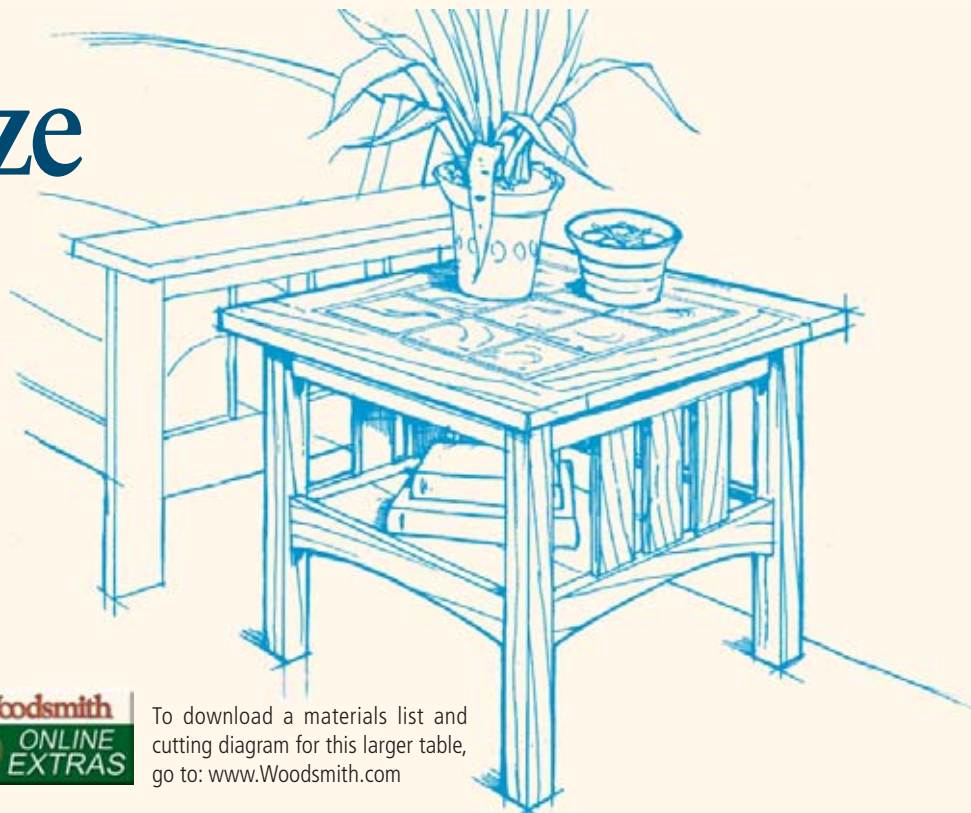

To download a materials list and cutting diagram for this larger table, go to: [www.Woodsmith.com](http://www.Woodsmith.com)

# SHOP NOTEBOOK

## Shallow Mortise Jig

One of my favorite features on the tool cabinet are the false tenons that accent the sides (right photo). They really draw your attention and give the cabinet a “hand-crafted” look.

But I didn’t want to knock myself out cutting all these mortises by hand. Routing them seemed like the best way to go. And for this job, I built the simple mortise jig that you see in the drawing below.

The jig is designed to be used with the dado cleanout bit shown on the left. Since this bit will cut flush to the template, the guide opening is sized to the mortise.

The easiest way to create an accurate opening is to piece the template together, as shown in the drawing below. When you glue the pieces together, you can leave an opening the exact length and width of the mortises. A cleat fastened to the template spaces the mortise at the correct distance from the edge of the cabinet sides.

To use the jig, just clamp it in place with the opening over the position of the mortise (detail ‘a’). After routing the mortises, I left the jig in place while I used a sharp chisel to square the corners. **W**



▲ The false tenons hide the screws in the cabinet sides and also add a nice detail.



▲ The dado bit is guided by a top-mounted bearing and has a longer cutting length than the cleanout bit.

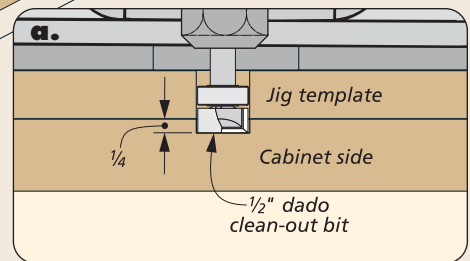
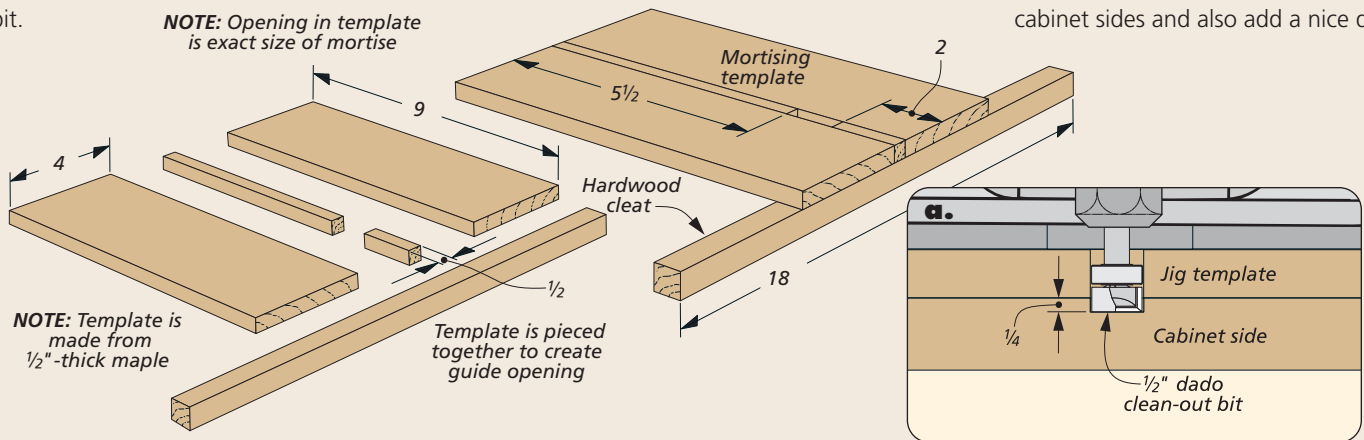

## How-To: Make Chamfered False Tenons

The challenge to making the chamfered false tenons for the tool cabinet lies in their small size. Once they’re cut to their final  $\frac{3}{8}$ " length, there’s just not much to hold on to when trying to chamfer the ends. The solution is to chamfer first, then cut them to length.

I started with a blank of wood sized to fit the mortises and long enough to make all 16 tenons. At the router table, I chamfered all four edges of both ends (Fig. 1). Then I took the blank to the table saw. Here I set up the fence with a stop block in front of the blade (Fig. 2) to gauge the length and cut each end off of the blank. Now repeat the process until all 16 tenons are completed.

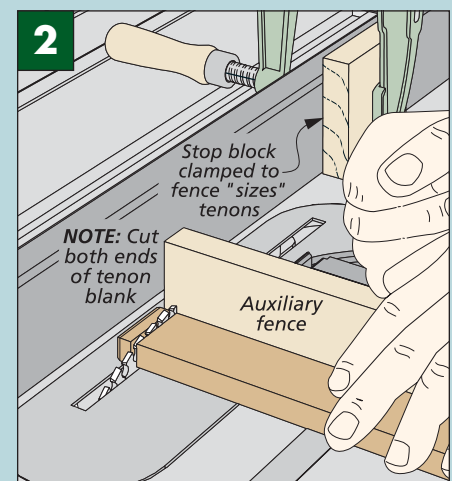
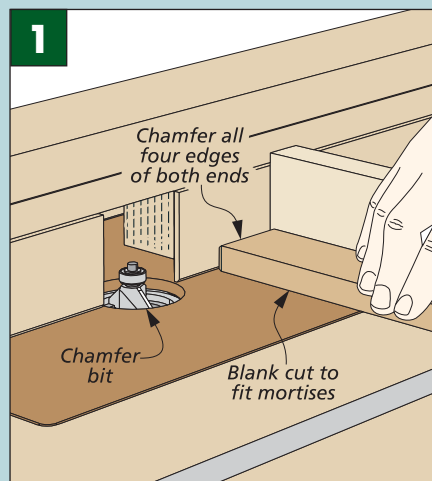

## Shaping Bead Molding

I used one of my favorite moldings, a simple bead, to add a classic touch to the bookcase project on page 24. Shaping the bead takes place at the router table using a roundover bit. The challenge here is the small size of the finished pieces. But there's a pretty easy way to get around this.

As you can see in Figure 1, the bead starts out as an extra-wide blank. This gives you plenty of material to hold on to as you work.

For the  $\frac{1}{4}$ " bead, you'll use an  $\frac{1}{8}$ " roundover bit as shown in Figure 1. To get a fully rounded bead, set the depth of the bit carefully so that after a pass on each side of the blank, the roundovers will meet

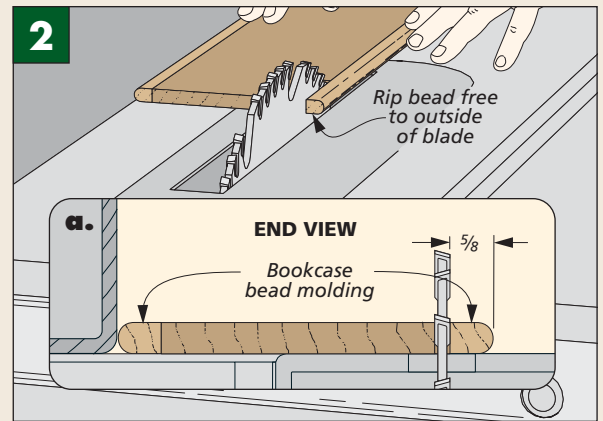
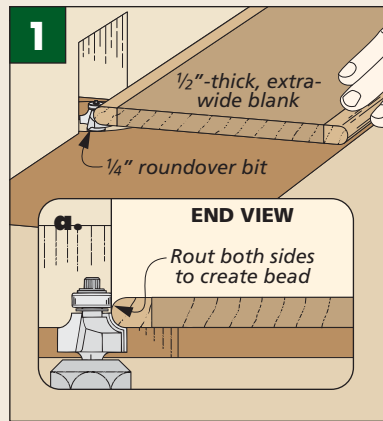

right in the middle of the blank, forming a half-round. As you can see in Figure 1a, the fence needs to be set on the money as well, since the bearing won't support the workpiece on the second pass.

After routing a bead on both edges of the blank, I take it to the table saw to complete the job. Just set the rip fence so that you can safely rip each bead free from the blank, as shown in Figure 2. **W**

## Shelf-Pin Hole Jig

It's pretty disappointing when you set a shelf in place only to find that you didn't drill the holes for the support pins accurately. A shelf that rocks from corner to corner or doesn't sit level wasn't in the plan. So when building the bookcase on page 24, I didn't leave this to chance. A simple jig made the job quick, easy, and foolproof.

The holes are in groups of five on 2" centers. So to space the holes accurately and keep them in a straight line, I started by making a drilling template out of plywood as shown in the drawing below.

Next, you need a way to space the holes  $1\frac{1}{2}$ " from the front edge and the rabbeted back edge of the case sides. To do this job, I attached a thin hardboard cleat to either side of the template. The two thin cleats will fit over the rabbet cut in the sides for the back panel. And with

a cleat on either side, the jig can simply be flipped over to drill the holes on the opposite edge. By using the same template hole to drill both the front and back, you'll ensure the holes will line up.

Finally, you need a way to accurately locate the jig on the case sides. To do this, first I squared a pencil line through the center template hole out to and across the edge of the template. This reference line can be matched up with layout lines on the case sides marking the location of the center hole in each group as in Figure 1.

Once the layout is complete, Figure 2 shows how to complete the job. Butt the guide up to the edge of the side and align it with your layout line. Clamp it in place and drill your holes. Then flip the jig over to repeat the process on the opposite edge. **W**

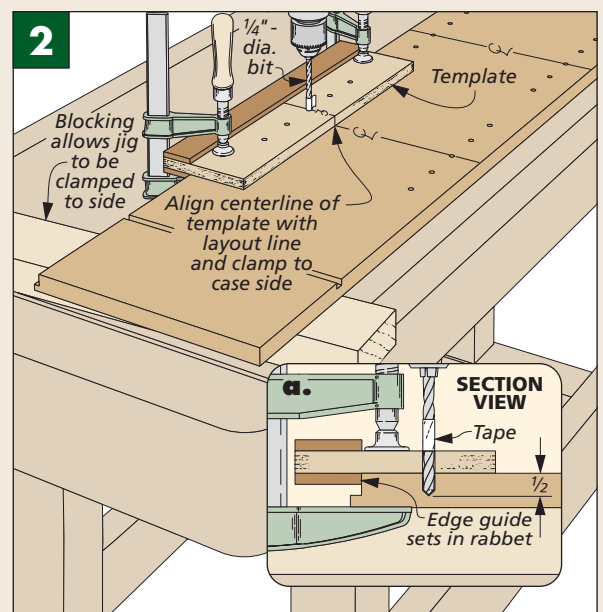
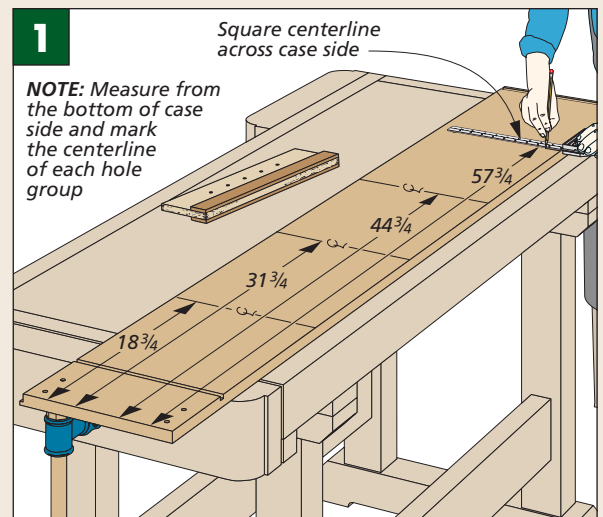
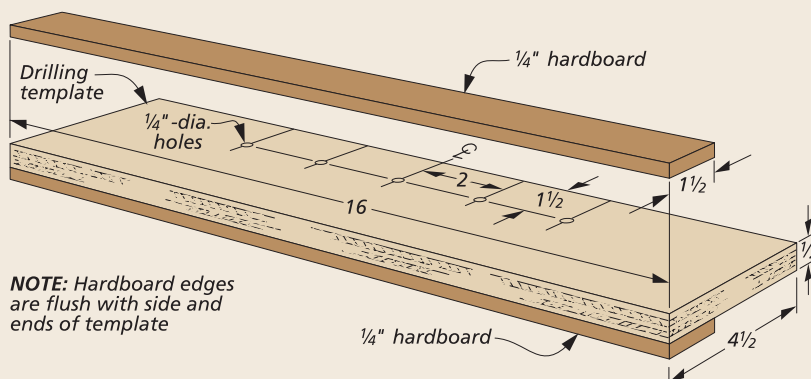

## classic Bookcase

Sure, it looks great. But that's only part of the story. This project is also versatile, easy-to-build, and solid as a rock.

It only takes a quick look at the photo at left to see that this classic-looking bookcase is a great way to transform some unused wall space into versatile storage. But it's not until you get into all the construction detail that you get the full picture.

**ONE SHEET.** For starters, the trip to the lumberyard will be easy on the wallet. The case and shelves can all be cut from one sheet of  $\frac{3}{4}$ " plywood. Throw in a few board feet of hardwood lumber and a piece of  $\frac{1}{4}$ " plywood and you're good to go.

**THE BASICS.** Once back at the shop, things will go just as easy. This bookcase is built to stand up to about any load, and all it takes to accomplish this is some basic joinery.

The case is built with sturdy, but easy-to-cut, tongue and dado joinery. So you'll have this part of the project together in no time. The face frame is more of the same. Biscuit joinery makes the job quick and easy without sacrificing any strength. Then, when you add some shop-made trim to the case, the bookcase takes on a whole new look.

But, believe it or not, there's one more feature that makes this project even better. And that's how easy it is to expand the bookcase to fill an entire wall, as shown on the following page. All you have to do is build multiple cases, modify the trim a bit, and then fasten them together. So you might say this project is "one design fits all."





# CONSTRUCTION DETAILS

OVERALL DIMENSIONS: 33"W x 13½"D x 73¾"H

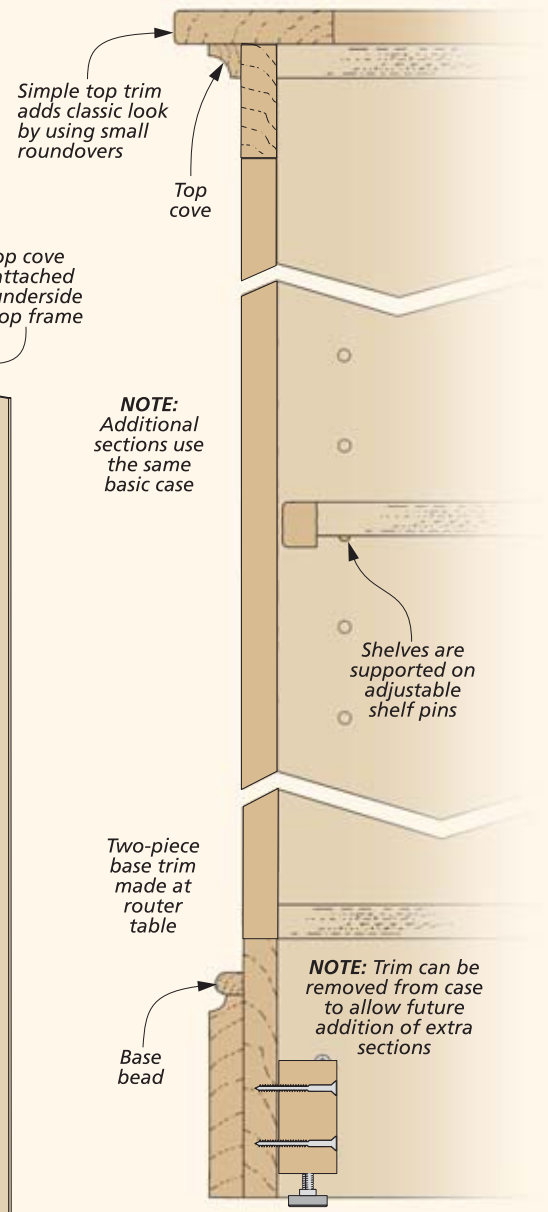
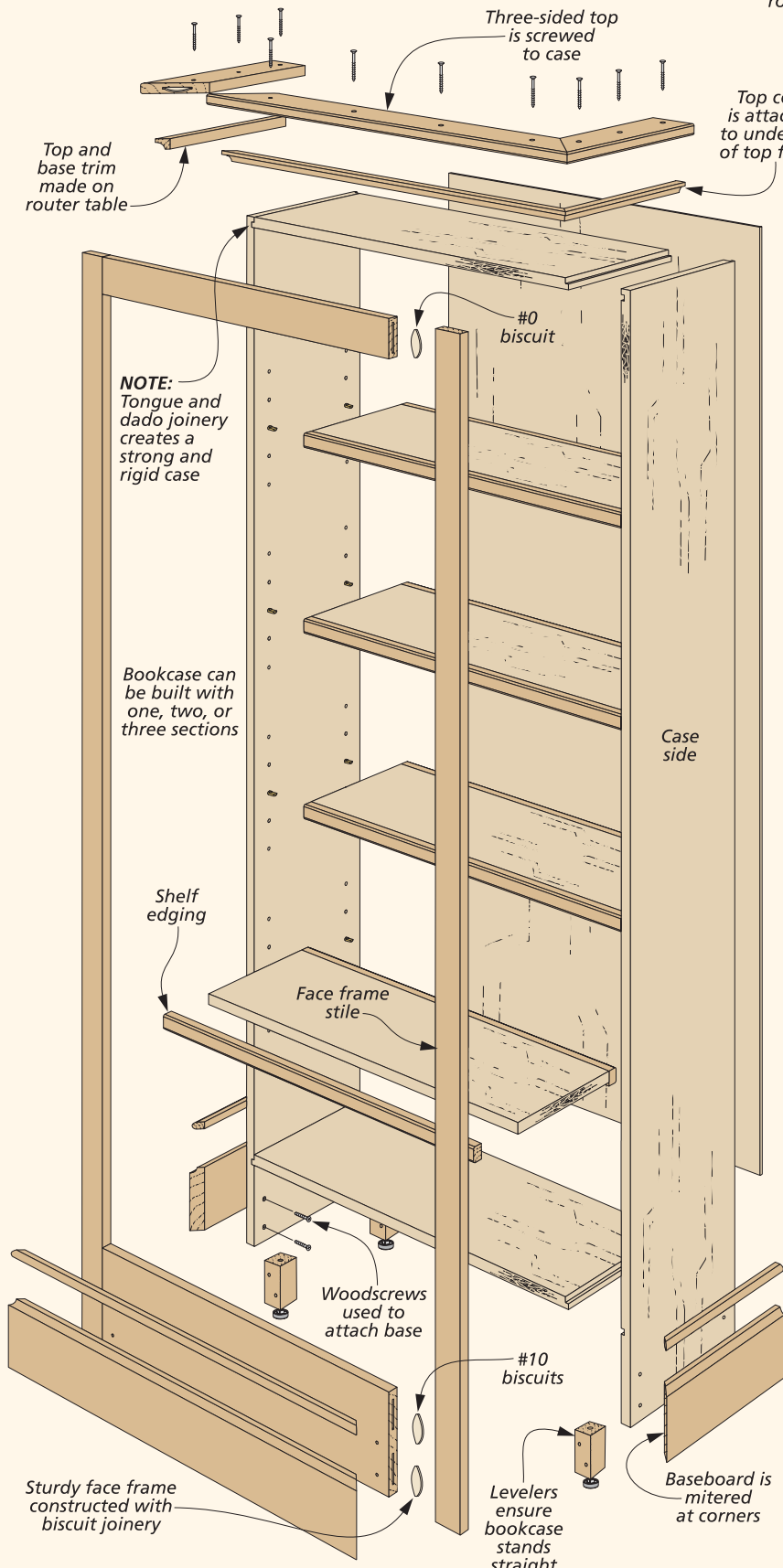

▲ If you like the looks of this project, why not expand it to cover an entire wall? Separately built sections make it easy.

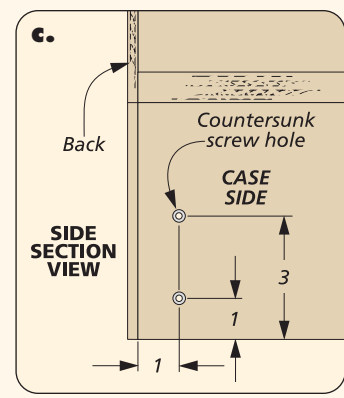
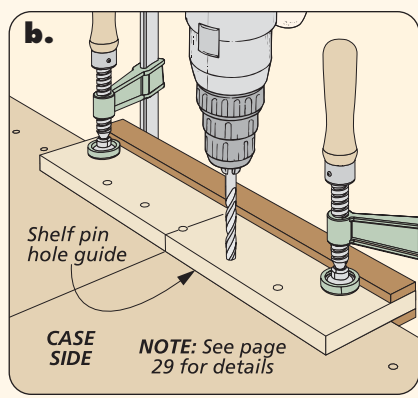
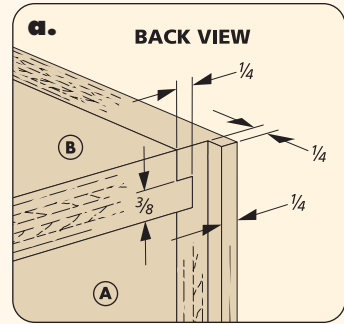
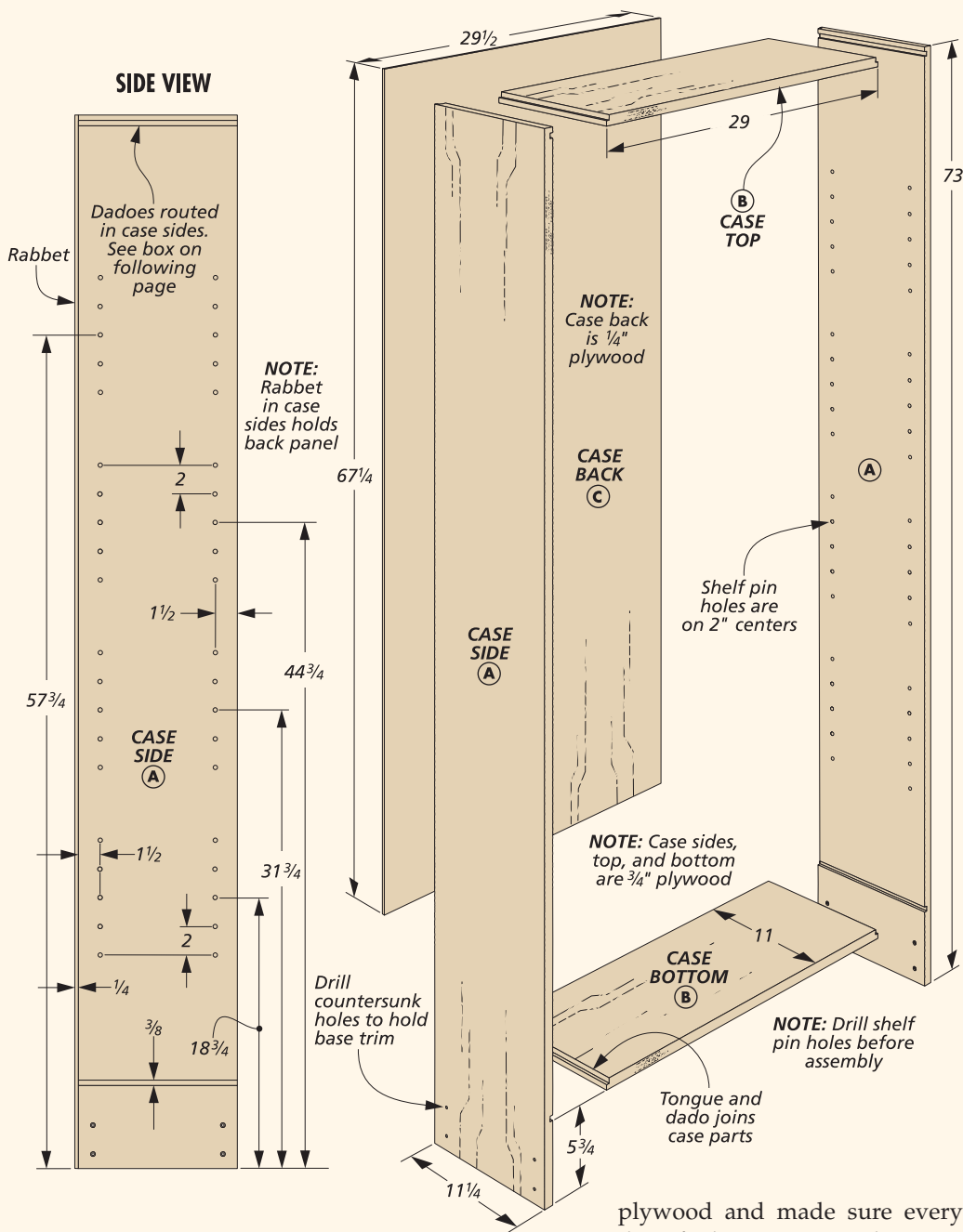

# building the CASE

My first goal here was to put together a solidly built plywood case. If you just take a look at the drawing above, you'll have a good idea of what's involved.

**LAYOUT.** As I said before, the bookcase is designed so that the main case parts and shelves can all be cut from one sheet of 3/4" plywood. So before I started cutting, I took a minute to lay out the parts on my

plywood and made sure everything fit the way I wanted it to.

**THE SIDES.** The major part of the work on the case involves making the two plywood sides. So once I completed the layout, I started by cutting the two *case sides* (A) to size.

Now you can start on the joinery. As you can see in detail 'a,' the case sides are joined to the top and bottom with a tongue and dado. This joint gives you good gluing surface and "racking" resistance.

Cutting the dadoes in the long case sides on the table saw would be pretty awkward. So the solution is to use a hand-held router and a simple edge guide, as shown in the box on the opposite page.

With this task complete, the next step is to cut a rabbet along the

back, inside edge of each side. This holds the 1/4" plywood back.

And to complete work on the sides, you'll need to drill some shelf pin holes. To do this quickly and accurately, I used a simple plywood drilling jig (detail 'b'). You'll find more about this on page 23.

**TOP AND BOTTOM.** That's it for the sides. Next up are the identical case top and bottom and there are just a couple things to mention here. First, since the back panel simply laps over the top and bottom, they're sized 1/4" narrower than the sides. And then a dado blade on the table saw will take care of cutting the tongues on the ends of the top and bottom (detail 'a').

At this point, I got out the glue bottle and a few clamps and

assembled the case. And then once the clamps come off, you'll want to cut the plywood back panel to size and glue it in place. This will help keep the case square and rigid while you add the face frame.

**FACE FRAME.** The face frame does more than just hide the plywood edges. It provides one more way to strengthen the case. So to make sure the face frame I added was up to the task, I did a couple things.

First, for added strength, I made the parts of the face frame pretty substantial — 2"-wide stiles, a 2½"-wide top rail, and a 6½"-wide bottom rail. And second, as you can see in detail 'a,' I got out my biscuit joiner to handle all the joinery. It makes the work go quickly and the face frame plenty rigid.

You'll have plenty of room for two #10 biscuits between the bottom rail and the stiles. But smaller #0 biscuits are a better fit in the top rail, as you can see in detail 'a.' Once the biscuit slots are cut, the face frame can be assembled and glued in place on the case.

**FOUR SHELVES.** I had two goals in mind when I made the plywood shelves. I wanted them to look pretty stout and to be "sag proof." I accomplished this by reinforcing both the front and back of the shelf panels with a sturdy, 1"-wide piece of edging (detail 'b').

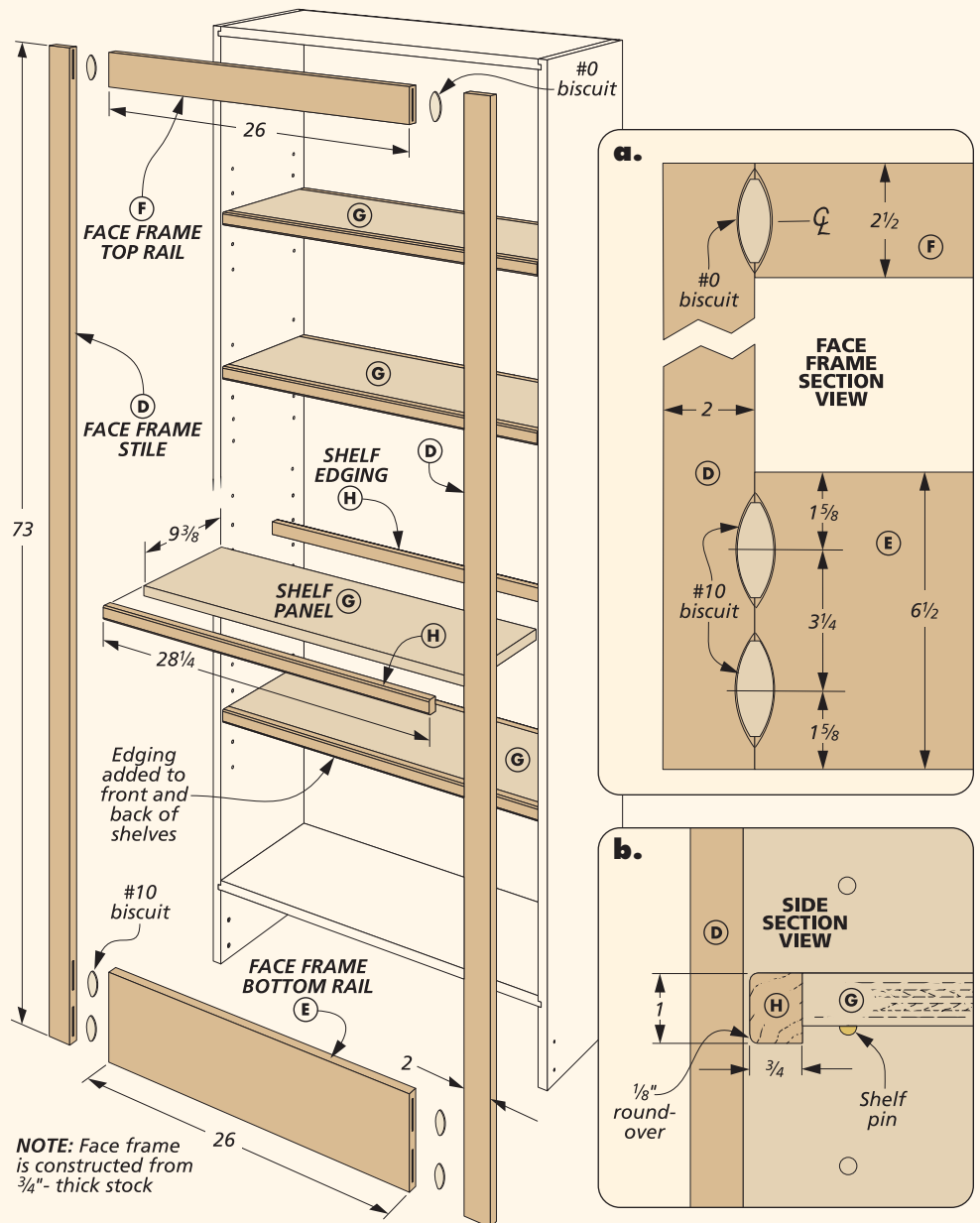

## How-To: Routing Dadoes

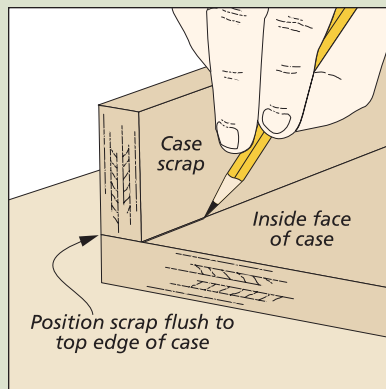

**Layout.** To ensure the case is flush across the top, use a scrap of plywood to lay out the dadoes in the sides.

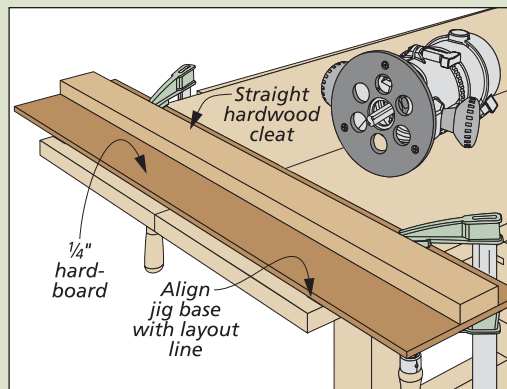

**A Simple Guide.** The two case sides are lined up and clamped edge-to-edge. Then a shop-made edge guide is used to accurately rout the dadoes.



▲ As you can see, the hardboard base of the guide has been trimmed so that the router cut falls right along its edge.

# adding the TRIM

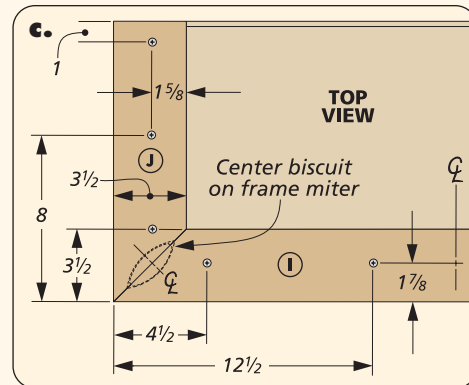
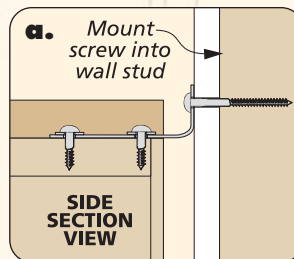
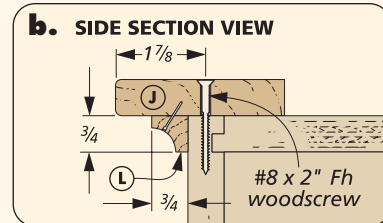
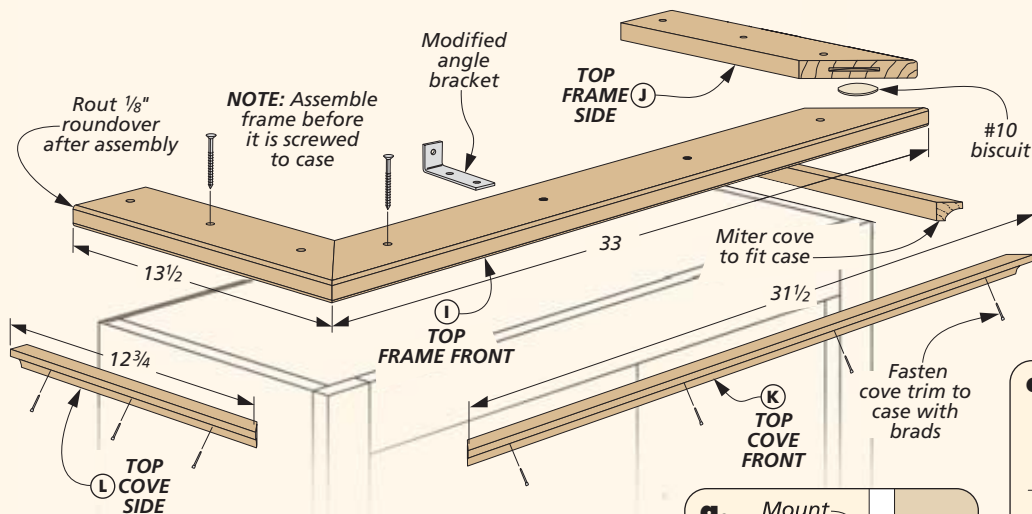

With the case complete, you can start work on adding the trim that dresses up the top and bottom. If you're building a single section, you'll find everything you need to know right here. For side-by-side sections, you'll need to do things a little differently. So check out the opposite page.

**THE TOP TRIM.** The drawings above show how to finish out the top of the case. First, I assembled a three-

sided mitered frame to create a wide overhang (detail 'b'). Biscuits will help with the assembly and keep the miters tight (detail 'c'). After assembling the frame, I eased the edges with a 1/8" roundover.

Once the frame is fastened to the case, the next job is to add the simple cove molding that fits beneath it. The cove can be made in short order at the router table and then

mitered to fit. Finally, I fastened the cove to the case and frame with glue and a few brads (detail 'b').

**ADD THE BASE.** Next comes the wide base trim shown in the drawings below. As you can see, it's made up of two separate parts, a wide baseboard with a cove routed on the top edge and a narrow bead that "caps" the coved edge.

To make this base, you'll need to spend a little time at the router table. Detail 'a' below shows the first step. After cutting the baseboard blanks to rough length, I routed the cove along one edge. Next, comes the 1/2" bead molding. Here, you can turn to page 23 for a short lesson on making bead.

When the bead is complete, it's glued to the coved edge of the baseboard. Then the completed trim is mitered to fit around the case. Wrap things up by gluing the trim to the case and adding screws for good measure (detail 'b').

**STRAIGHT AND LEVEL.** The final task is to make certain the bookcase always sets level *and* upright. To do this, I first installed a leveler in each corner of the case, as shown in detail 'b.' And then after the bookcase is completed and moved into place, it's a good idea to anchor it to the wall (detail 'a' above). This will eliminate any worry of the bookcase tipping forward. **W**

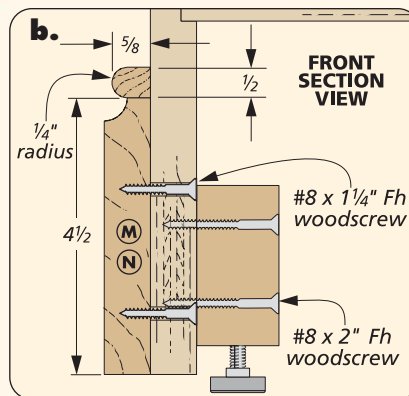
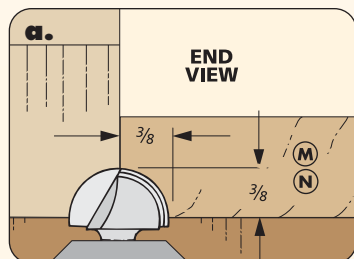
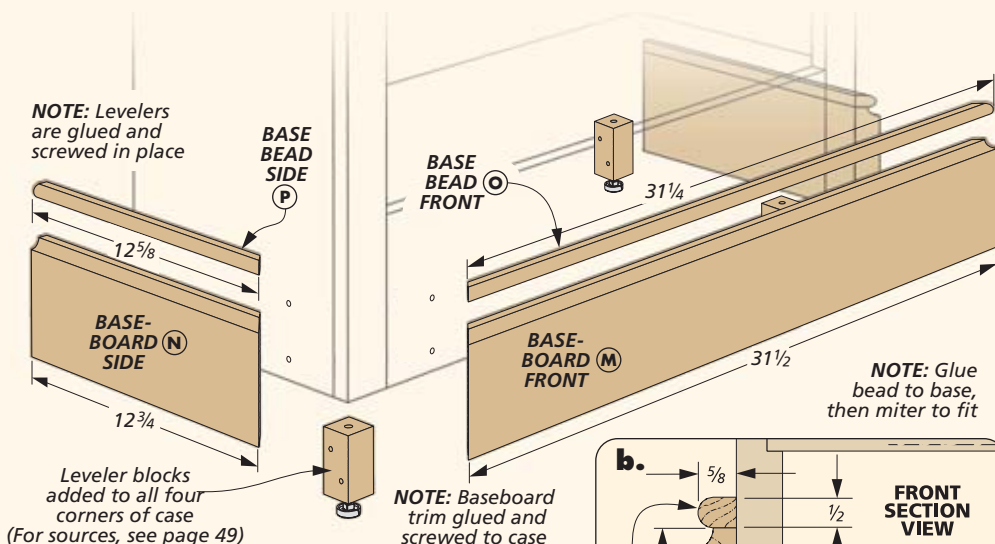

# DESIGNER'S NOTEBOOK

## Side-by-Side Bookcase

One of the nicest features of this bookcase is that you can combine as many sections as necessary to fit your wall space. And this only takes a couple of minor design changes.

The idea is that each section is built as a complete, separate unit. Then the sections are set side by side and fastened together with connector bolts as shown in the detail drawing below.

So there are no changes to how you build the basic plywood case. But since the sections have to butt tightly together, the top and bottom trim are fit a little differently.

For an end section, you'll miter the trim at the outside, but fit it flush with the case sides on the inside. (see drawings below). To make a center section, fit the front trim flush to both sides of the case.

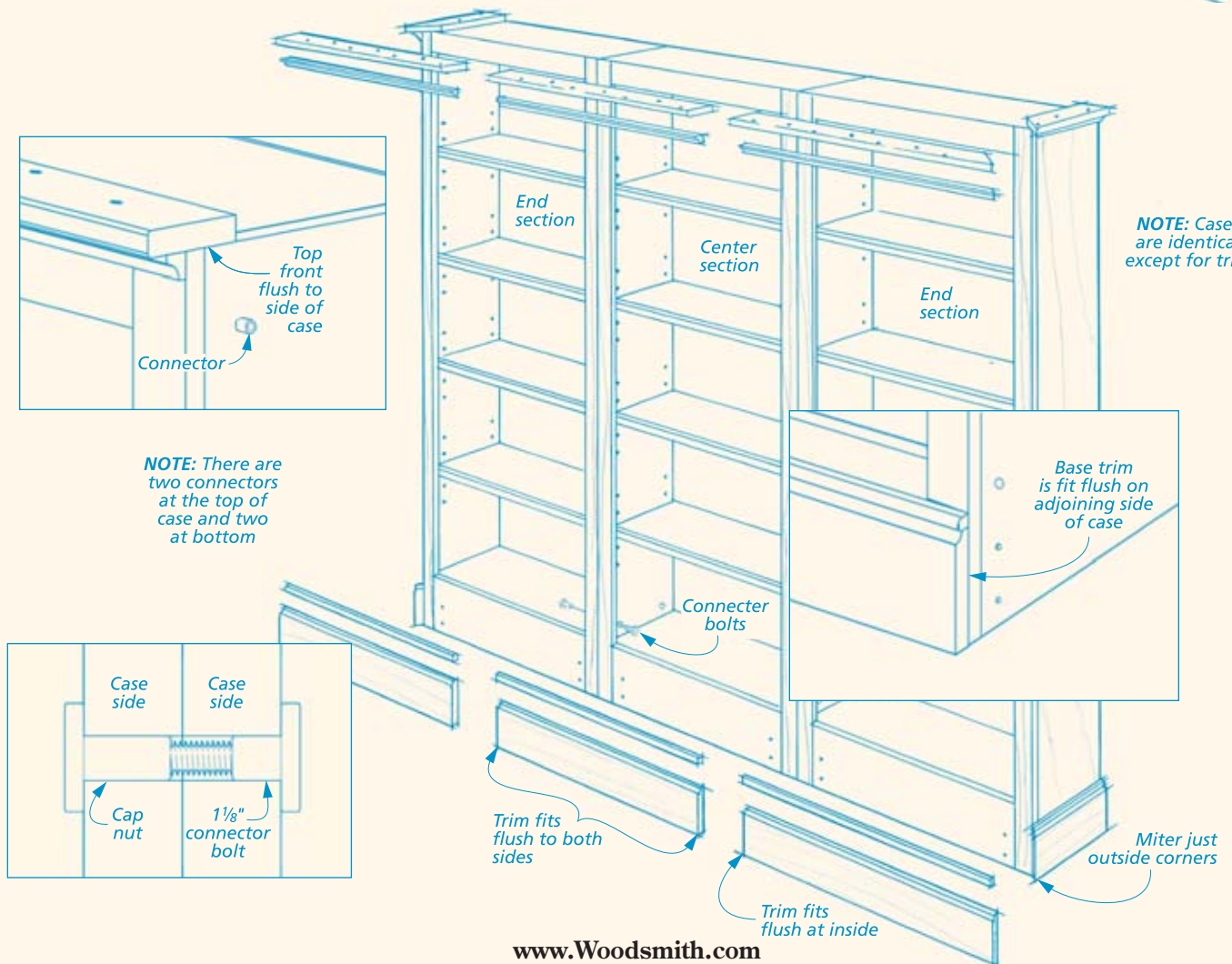

# 1-Hour Workshop

## Our Top 10 Workbench Accessories

These simple, shop-built devices help you get the most out of your workbench.

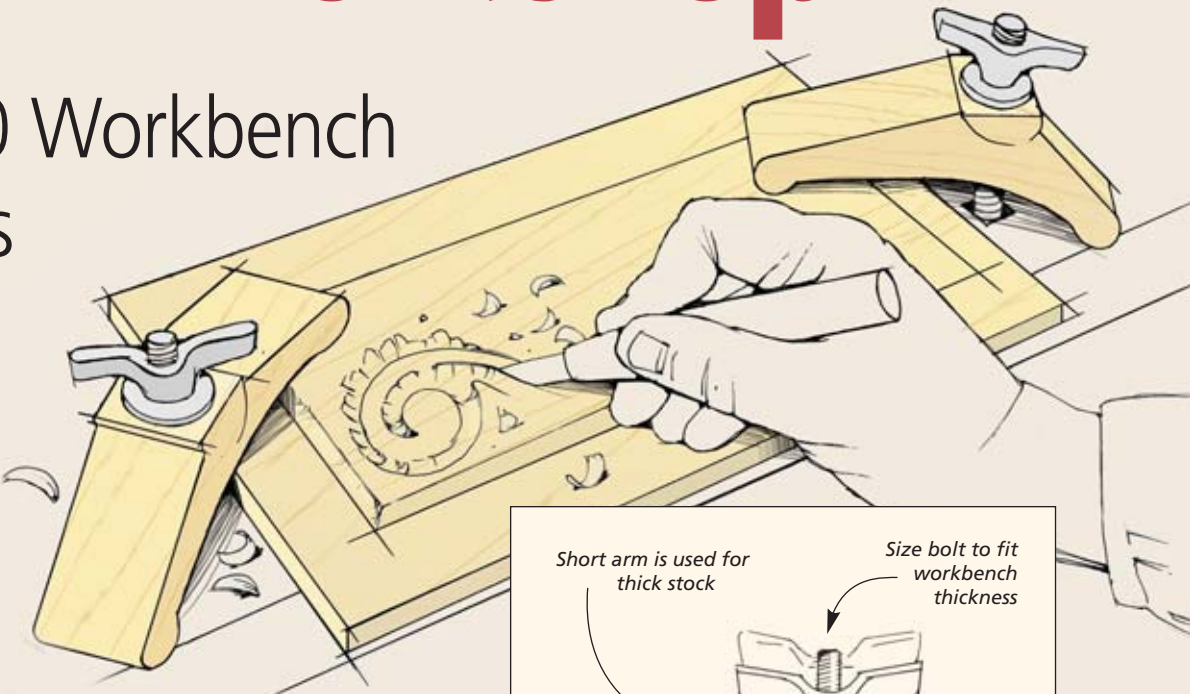

The workbench is the largest “tool” in my shop. And I use it for a lot of tasks. But even the best of tools can benefit from some practical accessories. The ten you see on these pages are the ones I use most often in my shop. Besides making tasks quicker, safer, and more accurate, these simple add-ons can be built with mostly scrap material and in less than one hour. That’s more than enough reason to add a few of these to your bench.

### Hold-Down Clamp

One of the keys to accurate hand work is making sure that your workpiece is held securely. That’s where the hold-downs you see in the drawings come into play. Since they’re

made from wood, they won’t mar your workpiece. And a large wing knob makes it a snap to tighten the clamp down or loosen it quickly to reposition the workpiece.

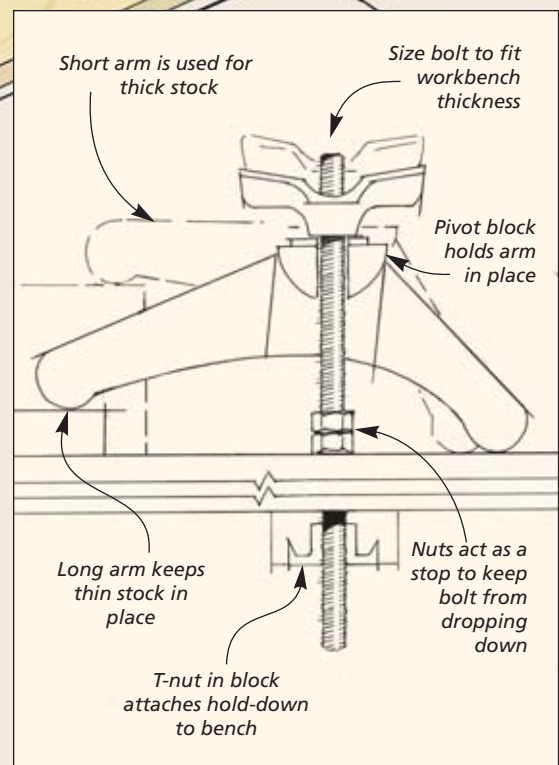
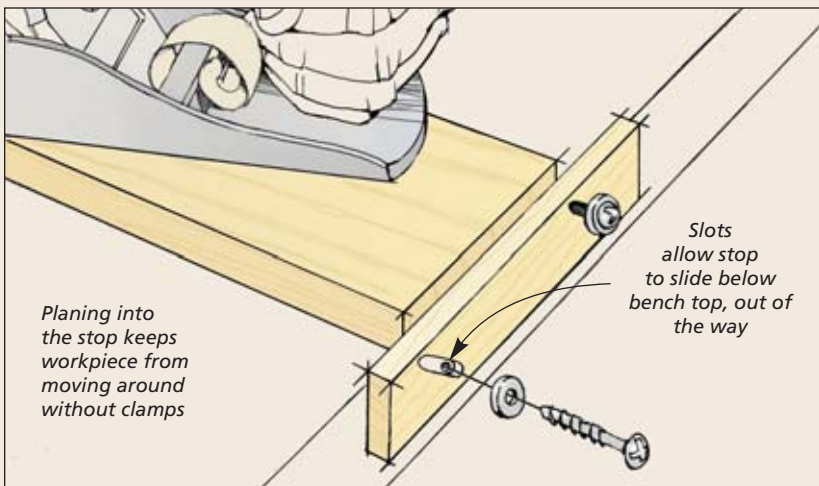

### 2 Planing Stop

Securing large panels to my workbench for planing or belt sanding was always a bit tricky. Clamps often get in the way of the tool and bench dogs are too narrow to keep the workpiece from shifting. To provide a solid stop for the workpiece, I attached this board to one end of the workbench. A pair of angled slots in the stop allow it to slide below the worksurface when it’s not needed. A couple of screws anchor it in place.

### 3 V-Block

The large, flat surface of my workbench is perfect for most of the work I do. But clamping a round or odd-shaped workpiece to the benchtop can seem more like trying to hold onto a wet bar of soap.

To make it easier to grab and hold these pieces, I turn to the simple, two-part V-block you see here. I made mine from a section of "two-by" stock. The base can be any length, but I found 12" to be about right. It provides a stable, wiggle-free platform for drilling, shaping, or smoothing. A shorter top piece gives the clamps a flat spot to lock the part in place without marring it.

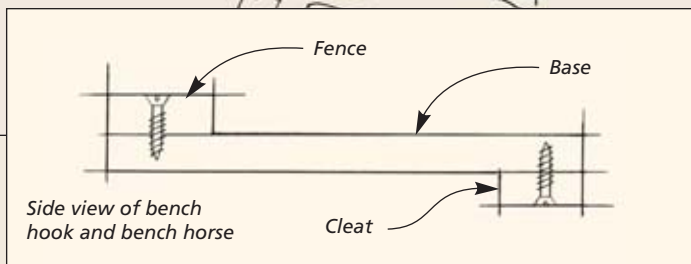
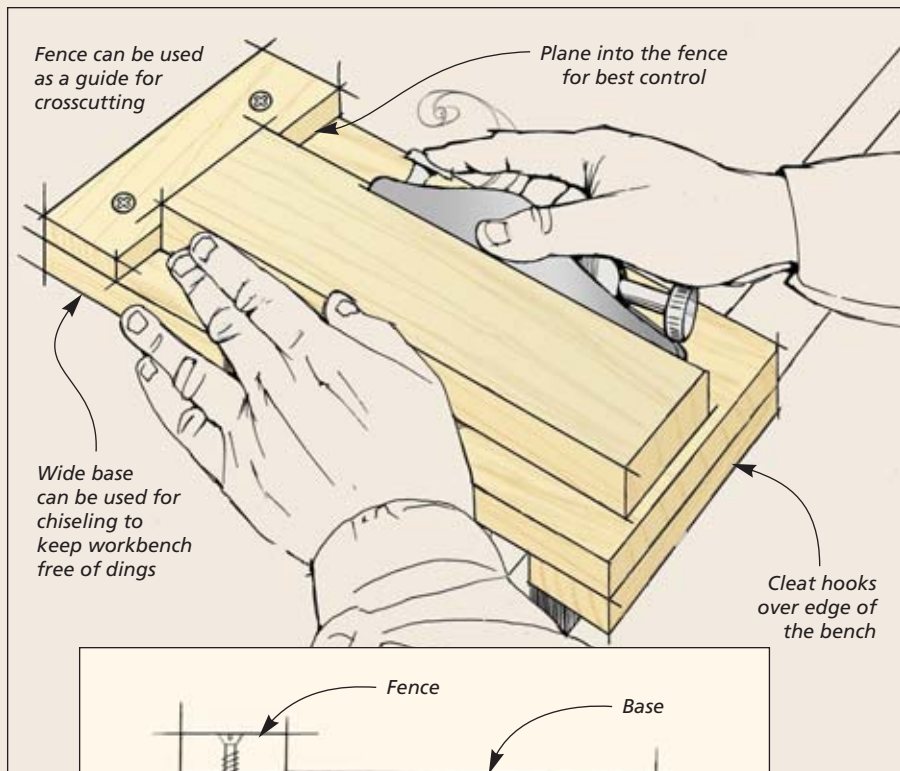
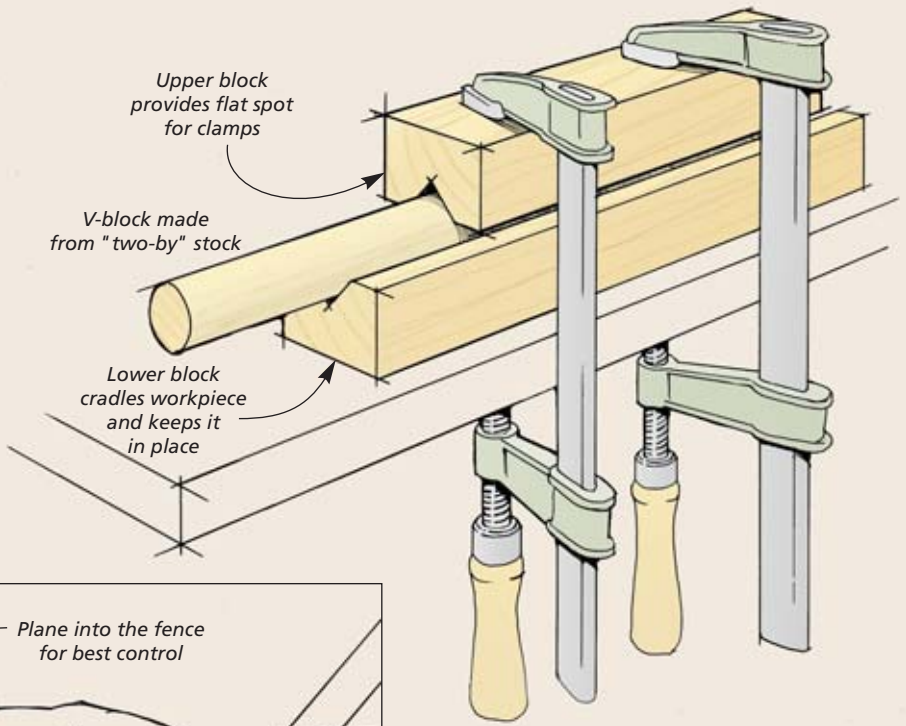

### 5 Bench Horse

I like to think of these narrow bench hooks as benchtop saw horses. They raise a workpiece high enough off the benchtop to crosscut the end without damaging my bench. I also use them for trimming tenons.

It's a good idea to make at least two so you can support long stock. I made mine the same depth as the full-size bench hook shown above. This way, they can serve as "outfeed" support so long workpieces won't sag.

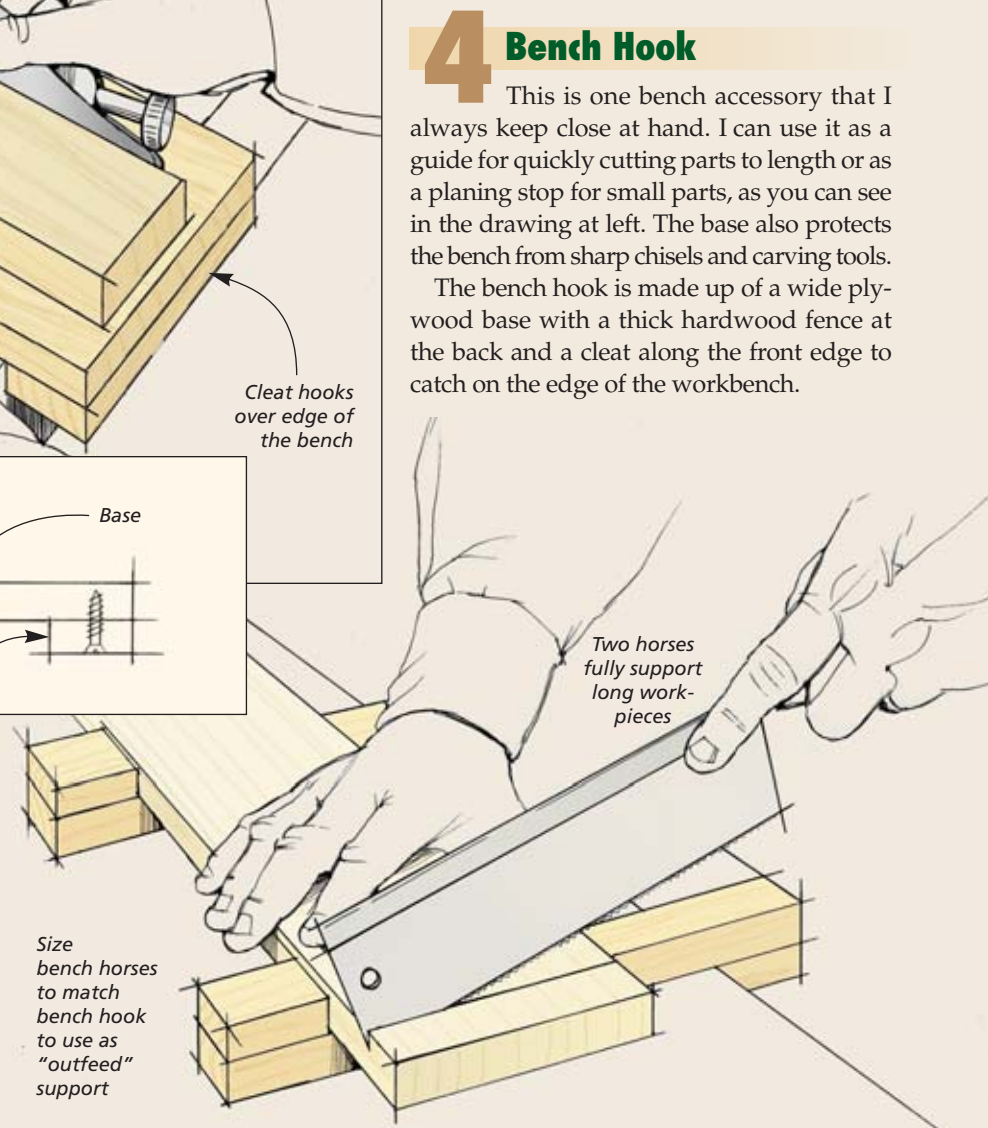

# accessories for the **BENCH VISE**

## 6 Small Parts Platform

Hunching over a bench while working on a small workpiece is a good way to get a back ache. And securing a small, thin part to a large workbench top can be another problem. But the solution to these two problems is a plywood platform that couldn't be simpler to make.

The plywood top is small and thin enough to securely clamp a workpiece on all four sides for carving, or other close-up work. I've also found this platform comes in handy as a small parts assembly table.

The raised platform at right is just two small pieces of plywood joined into a "T" shape with a dado and some glue and screws. Just be sure the bottom leg of the "T" is long enough to bring the platform up to a comfortable working height when it's clamped in a bench vise.

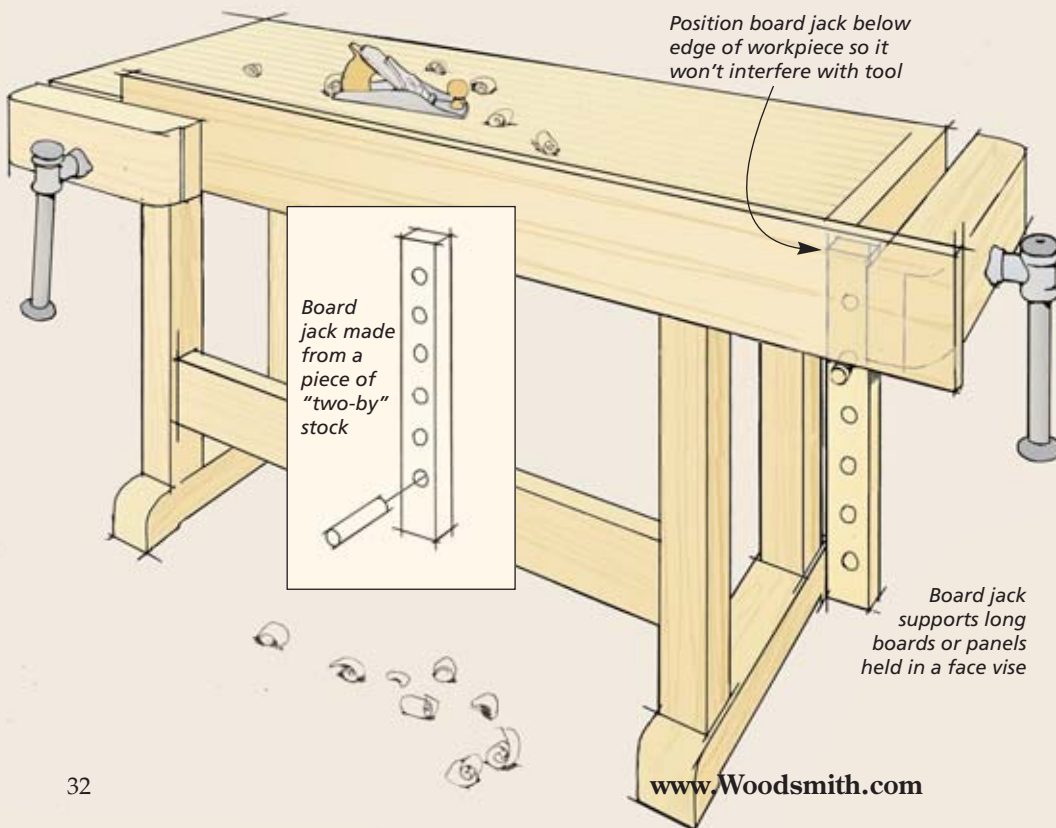
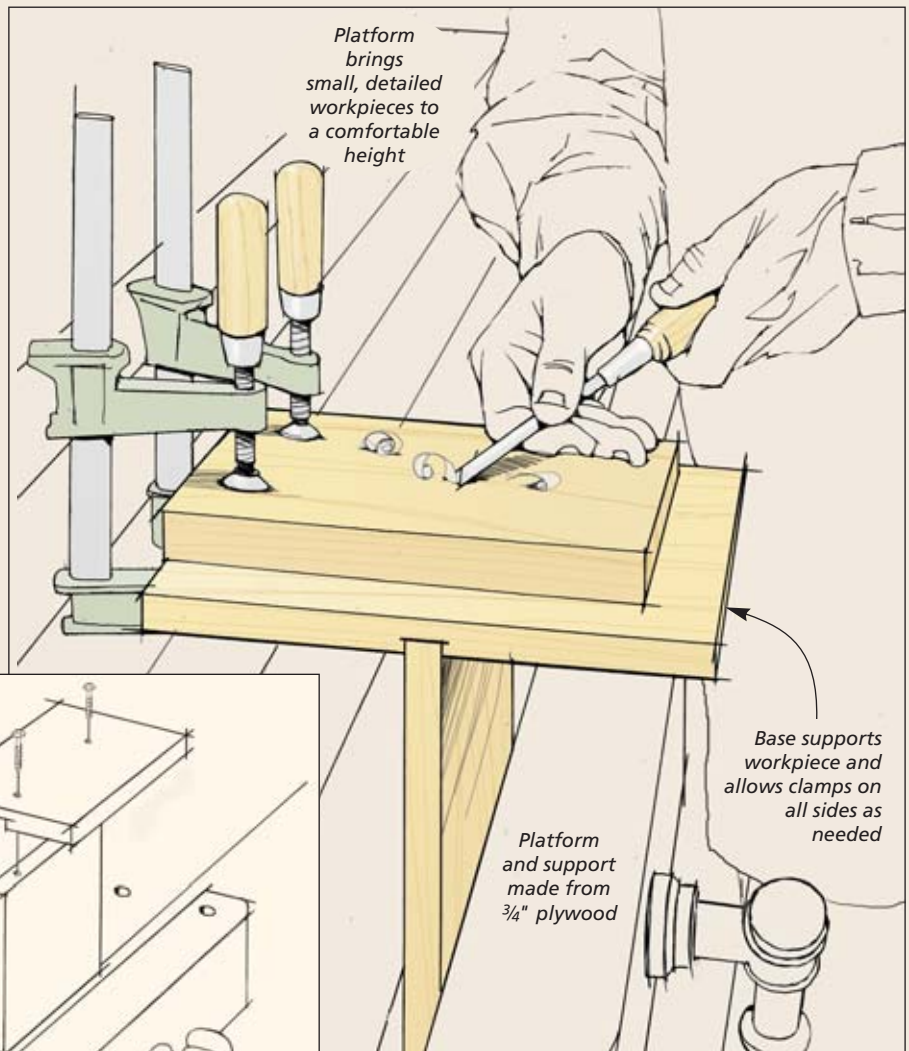

## 7 Board Jack

Like small parts, clamping and supporting long boards or wide panels to a workbench can pose some challenges. Especially if you need to work on the edges of these pieces.

The solution I use isn't really new. In fact, it's been used by woodworkers for hundreds of years. It's called a board jack. (Although some people call it a "sliding deadman.")

As you can see in the drawing at left, the board jack supports the opposite end of a long workpiece while it's clamped in the face vise. Although some board jacks are permanently attached to the workbench, mine is just a board that gets clamped in the end vise. A row of holes drilled along the length and a short wood peg make it easy to adjust for the width of the board or panel.



## 8 Miter Shooting Board

A poor-fitting miter joint on a project sticks out like a sore thumb. However, trimming it to fit tight on the table saw or miter saw can be a challenge. That's when I like to turn to a sharp hand plane and this miter shooting board. With the shooting board, I can hold the workpiece firmly against the angled fence. Then I can trim a bit at a time to sneak up on the fit. The plane is guided by a wide rabbet cut in the edge of the base. A pair of fences attached to the base allow you to trim right or left miters.

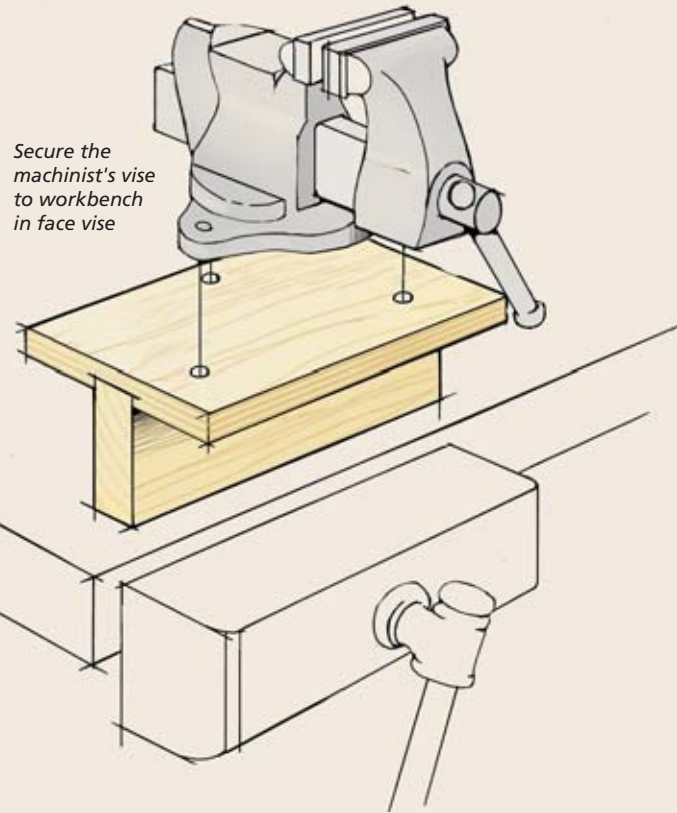
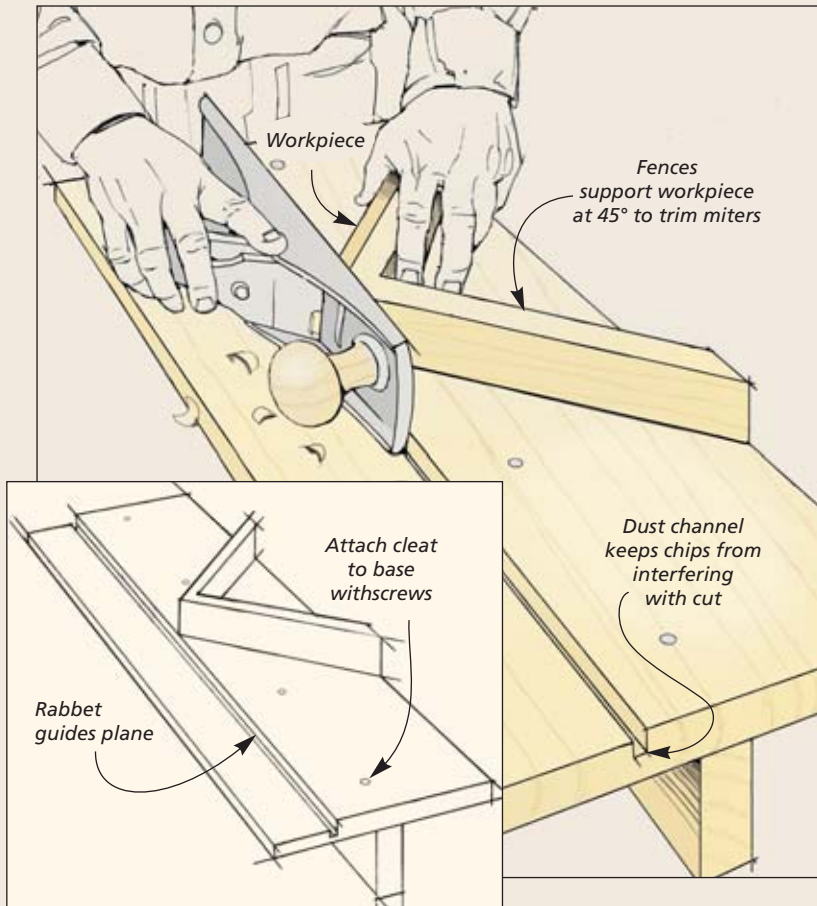

## 9 Add a Machinist's Vise

While I work with wood most of the time I'm at my bench, there are times when I need to cut, file, or shape metal. For that, a machinist's vise comes in pretty handy. But I don't want or need it on my bench all the time. To make for easy use, I bolted the vise to a plywood base that has a cleat on the bottom. The cleat gets clamped in the face vise of the workbench and holds the metal vise steady as a rock.

## 10 Mini Miter Box

Zing! If you've ever tried to cut small pieces of molding on a power miter saw, you know the sound a piece makes as it catches on the blade and goes whistling across the shop. Besides being difficult to control, cutting small parts on the miter saw can sometimes lead to tearout and rough cut edges.

A cleaner and safer way to make those cuts is to use a hand saw and the small miter box you see in the drawing at right. It clamps securely in a bench vise. A kerf for 90° and left and right 45° cuts in the fence guides the saw for smooth cuts every time.

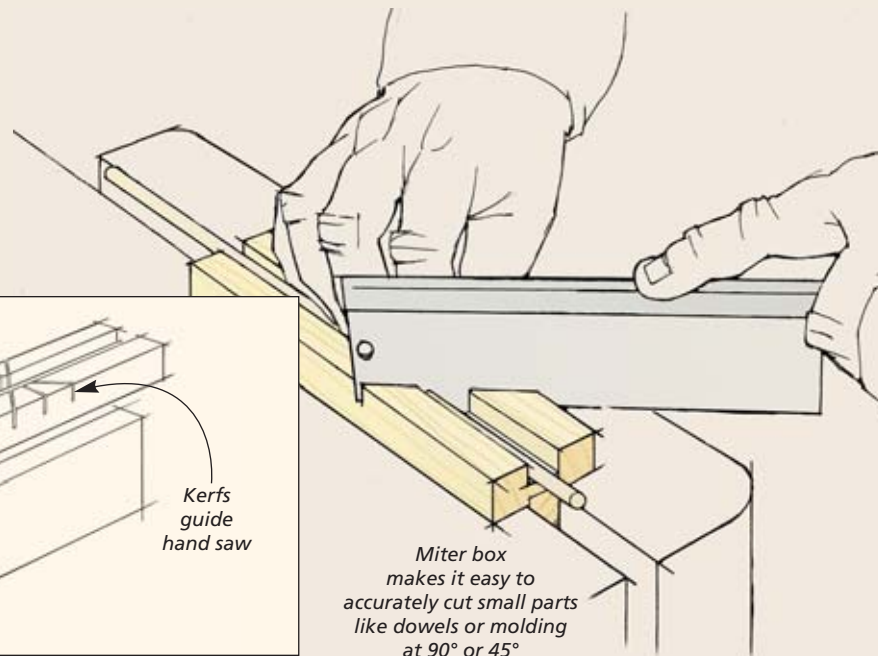
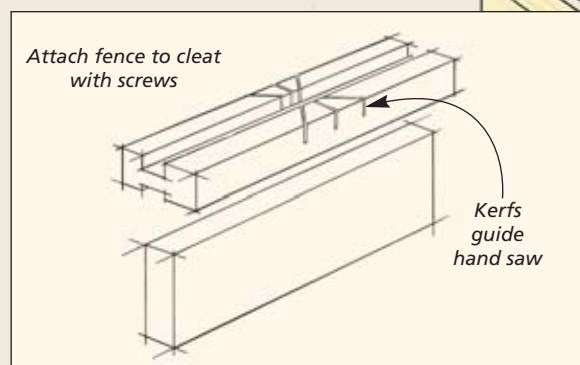



classic oak  
**Tool Cabinet**

# CONSTRUCTION DETAILS

OVERALL DIMENSIONS: 36¼"W x 20"D x 48"H

Build a companion fine tool chest starting on page 42

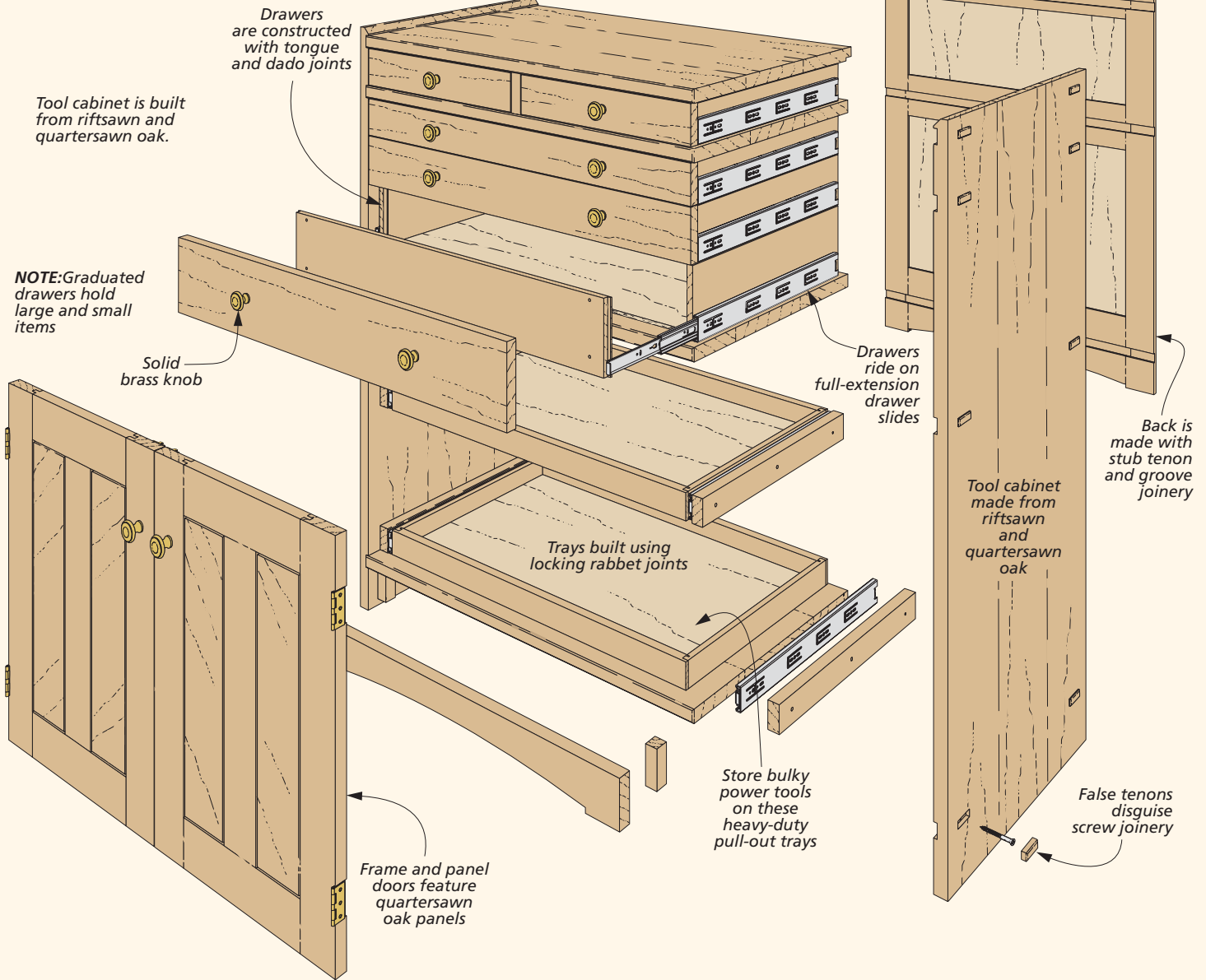

**Heavy-Duty Trays** hold portable power tools and other accessories. Now nothing will get lost in the back of the cabinet.



**Easy-Access Drawers** travel on smooth-riding slides. The shallow drawers make finding and organizing tools a snap.



**False Tenons** give the look of more complex through-mortise and tenon joinery. Chamfered edges add a nice detail.

# lower case CONSTRUCTION

I like to think of this tool cabinet as the trusty sidekick to my workbench. I do most of my work at or near the workbench — everything from planing and routing, to trimming joints and assembly. So it's important to have all the tools I need close at hand.

When it comes to building a big project like this, it can be a little intimidating. So I find it's helpful to step back and break it down into sections so you don't get overwhelmed by the details. That's what I did here. The tool cabinet is made up of four different elements: the case, doors, drawers, and trays.

**SOLID WOOD CONSTRUCTION.** The first section of the cabinet to build is the case, as shown in the drawing at right. Since all the case members are the same thickness, I glued up all the parts at one time.

With such large solid-wood panels, it's a good idea to spend some extra time in selecting and arranging your stock for color, grain, and appearance.

**DADO JOINERY.** At first glance, it looks like the case is built with

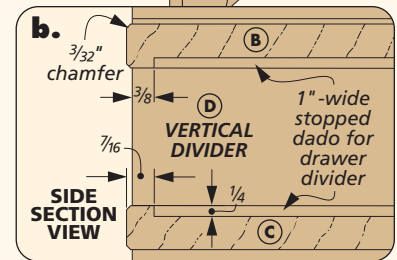
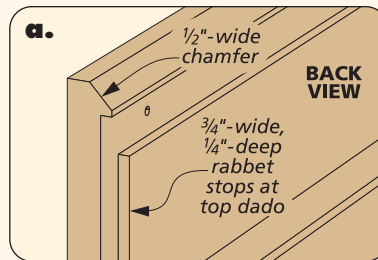
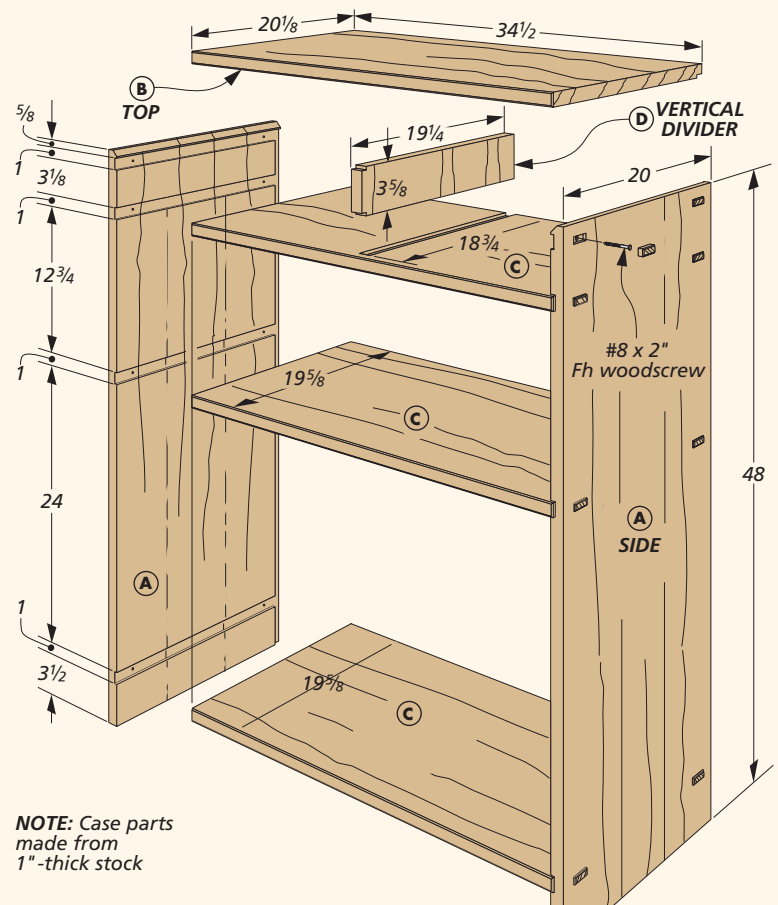

through-mortise and tenon joinery. However, the tenons you see are simply plugs. They hide long woodscrews that secure the sides to the horizontal parts. Dadoes on

the inside of the case help support the dividers. Using false tenons and screws gives you a traditional look without all the work.

The case is assembled with simple dado joints. You can cut the dadoes with either a table saw or hand-held router. It's not important how you cut the dadoes. But because the ends of the dadoes are visible, it is important that the bottoms of the dadoes are smooth and flat. (I prefer to use a dado clean-out bit to end up with the smoothest bottom possible.)

There's just one other thing to mention about the dadoes. They should match the thickness of the stock as close as possible for the tightest, strongest joint.

**SIDE DETAILS.** Before moving on to the dividers, there are a few more things you'll need to do to the sides. First, cut a chamfer along the top

## Shop Tips: Chamfers and Slides

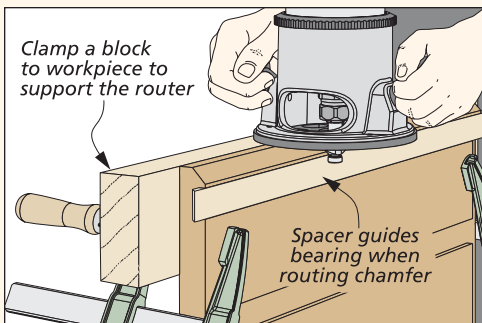

**Routing the Chamfer.** A support board clamped to the case side and a spacer in the dado allow you to easily rout the chamfer.

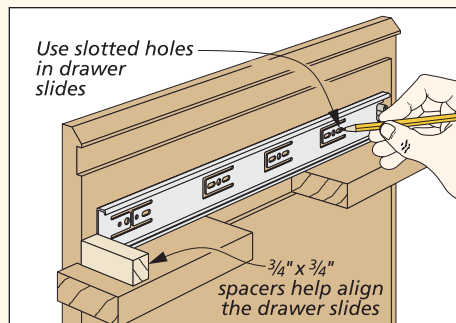

**Drawer Slides.** Pre-drill the holes for the top drawer slides before assembly. Support blocks and a spacer keep things aligned.

inside edge of each side panel. Take a look at the left box on the bottom of the opposite page for a tip on the best way to do this.

The second thing to do is rout a rabbet on the back edge to hold a frame and panel back that is made later (detail 'a' on the opposite page). This rabbet is stopped at the top divider dado and doesn't run the whole length of the side.

The last thing you'll need to do is rout small mortises in each side to hold some false tenons that hide woodscrews. I used a simple router template to do this. It's shown below and on page 22. Even though the case is going to be glued, the end-grain joints need some screws for reinforcement.

**SIMPLE DIVIDERS.** At this point, you can set aside the sides and work on the dividers. These are the horizontal panels that make the top, bottom, drawer, and cabinet dividers. You can see the dimensions for each divider in the drawing.

The front edge of each divider sits proud of the case sides and is chamfered on the front. Plus, the case top and upper drawer divider have centered, stopped dadoses cut in each panel to hold a short, vertical divider between a pair of narrow drawers. You can

see this illustrated in detail 'b' on the opposite page.

There's one last thing to do before assembling the case. And that's to install the drawer slides for the two upper drawers. I did this now because after the case is together, it will be nearly impossible to reach inside the small opening, drill the holes and then align

the slides. Take a look at the right drawing on the opposite page to see how I did this. The case can then be assembled.

**APRON AND GLUE BLOCK.** To complete the front of the case, I added an apron at the bottom, as in the drawing above. It has a shallow arch and is glued to the divider above and a pair of glue blocks.

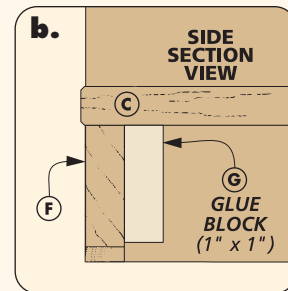
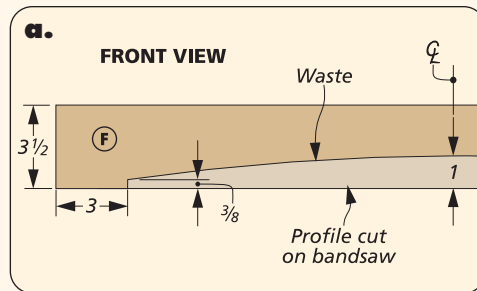
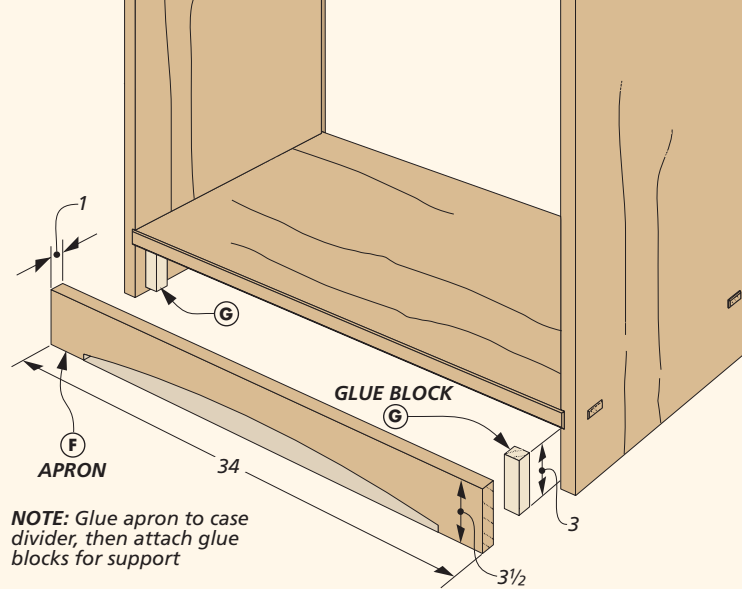

## How-To: Hiding Screw Joints With False Tenons



▲ A simple router template and a hand-held router are all it takes to cut the shallow pockets for the false tenons. To find out how to make the template, turn to Shop Notebook on page 22.

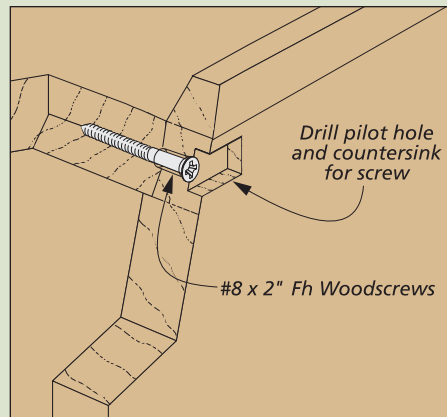

**Woodscrew Reinforcement.** After routing the pocket for the false tenon, square up the corners with a chisel and drill a countersunk shank hole and pilot hole for the 2"-long woodscrew.

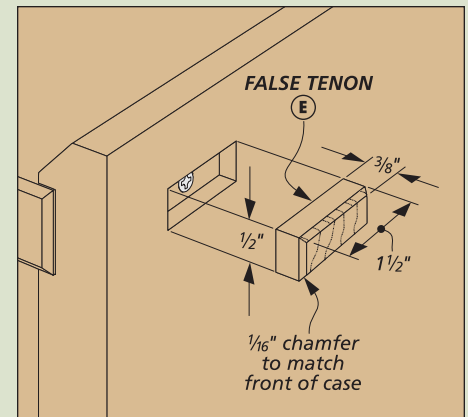

**Hide the Screws.** Chamfered false tenons fit snugly in the pockets routed in the cabinet sides and hide the woodscrews. Once they're made (turn to Shop Notebook on page 22), simply glue them in place.

# frame & panel CASE BACK & DOORS

All that remains to complete the case of the tool cabinet is the back. The back assembly is made with simple stub tenon and groove joints. For step-by-step instructions on how to make this strong joint, take a look at the "How-To" below.

**STRENGTHENING THE CASE.** Besides closing in the case, the back also adds strength. You can see what I mean in the exploded view at right. First, it fits into the rabbets cut in the sides of the case. This prevents the case from racking. After the back is glued up, a series of dados and grooves are cut to fit over the horizontal dividers to keep the large case rigid and square.

**BUILDING THE BACK.** I began by cutting grooves on the inside edges of the stiles and rails. Then stub tenons can be cut on each end of the rails. Note: The joinery for the door frames is identical to the back. To save time, you could cut the door rails and stiles here as well.

Once the joinery is complete, I cut a small arch in the bottom rail to match the front skirt, as shown

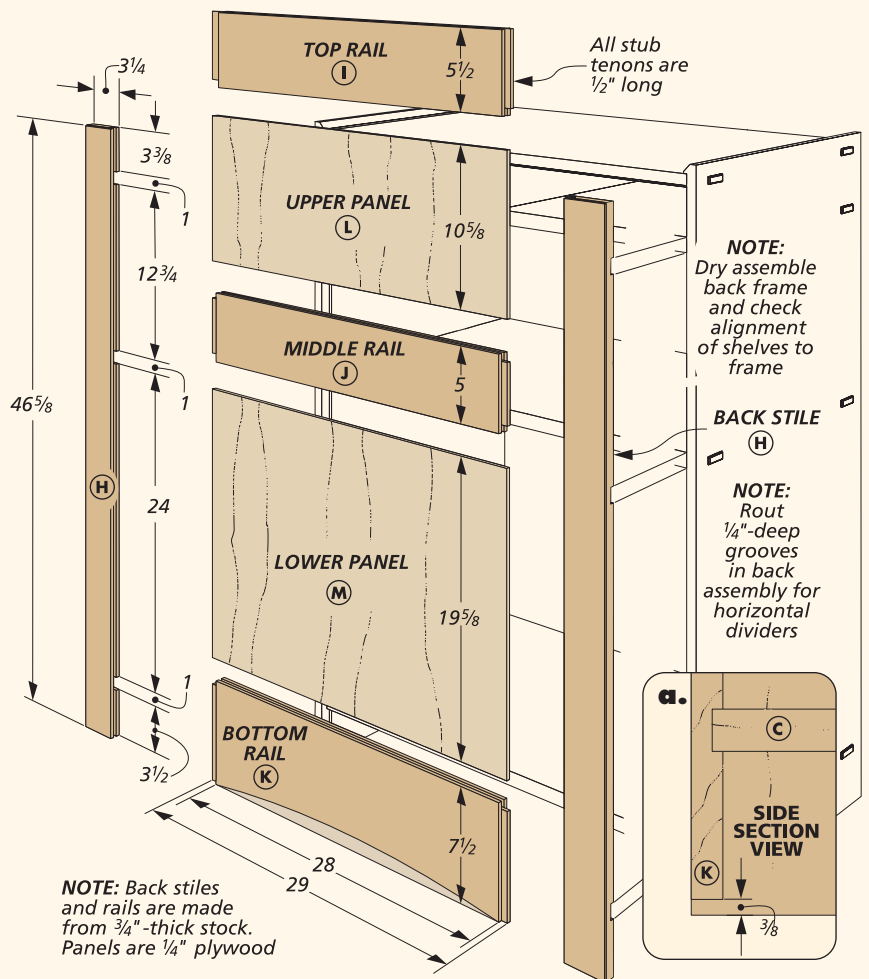

**NOTE:** Back stiles and rails are made from  $\frac{3}{4}$ "-thick stock. Panels are  $\frac{1}{4}$ " plywood

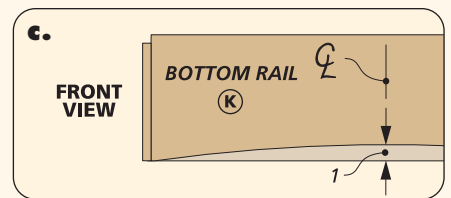
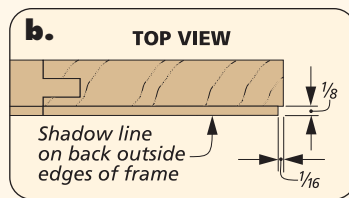

in detail 'c.' Finally,  $\frac{1}{4}$ " plywood panels are cut to fit the grooves. Now the back assembly can be glued together (including the panels). Note: Bottom rail (K) sits  $\frac{3}{8}$ " up

from the end of the rails, as in detail 'a.' Finally, I routed grooves to fit over the dividers and a small shadow line around the outside edges, as in detail 'b.'

## How-To: Stub Tenon & Groove Panels

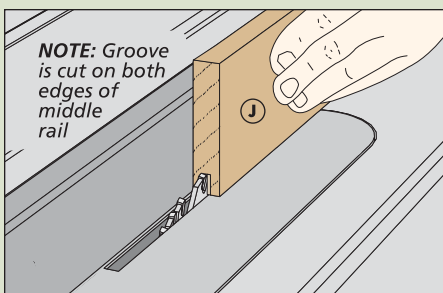

**Grooves.** The first step is to cut a  $\frac{1}{2}$ "-deep, centered groove on the inside edge of the rails and stiles. The groove is sized to match the thickness of  $\frac{1}{4}$ " plywood.

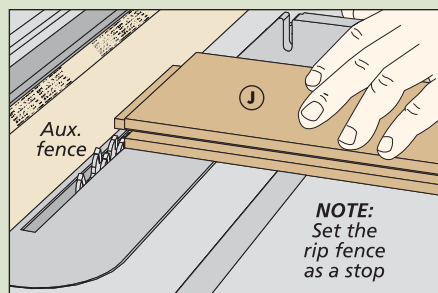

**Tenons.** The next step is to cut the stub tenons on the ends of the rails. Position the rip fence as a stop and cut the stub tenons with a dado blade.

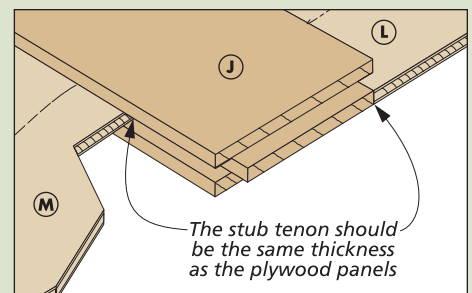

**Panels.** The center panels are sized to fit between the stiles and rails. Plywood panels can be glued in place. Solid-wood door panels are allowed to "float" in the grooves.

## Solid-Wood Doors

With the case complete, I moved on to building the doors. Like I mentioned earlier, the joinery here is the same as the case back. There's one difference between the doors and the back. The panels in the doors are solid wood, instead of plywood. They're solid wood for appearance. I wanted them to look as good when they were open as closed. And to make them stand out from the frame, I selected straight-grained (riftsawn) stock for the frame parts and used highly figured quartersawn wood for the door panels.

**DEALING WITH WOOD MOVEMENT.** With the parts cut to size, you can then cut the joinery on the stiles (N, O) and rails (P). Because the panels (Q) are solid-wood pieces, they are cut slightly narrower than the grooves so they can expand and contract.

Next, I cut a rabbet on all four sides of the panels to form a tongue, as in detail 'b.' The rabbets are cut a little wider than the grooves to create a shadow line so that they stand out even more.

At this point, you can assemble the doors. I applied glue only to the stiles and rails. The panels need to "float" in the grooves to expand and contract. But to keep the panels centered in the frame, I applied a dot of glue at the top and the bottom of the panels and used some

spacers while clamping. It's also a good idea to stain them as well, as you can see in the shop tips below.

**HANGING THE DOORS.** The doors can now be hung in the case. To do this, I cut shallow notches in the sides of the doors, as in detail 'c,' to hold

the hinges. The notches are  $\frac{1}{8}$ " less than the thickness of the hinge knuckle. The hinges will be surface mounted on the inside of the case. Then the doors can be trimmed to fit. All that's left is to attach the knobs and catches, as in detail 'd.'

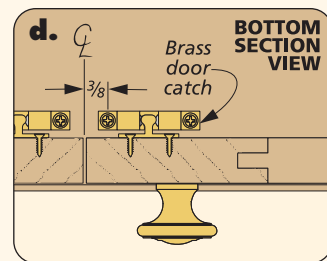
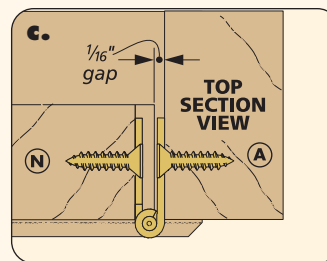
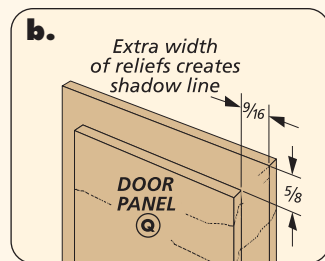
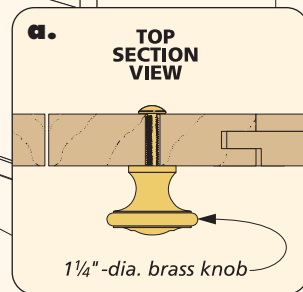
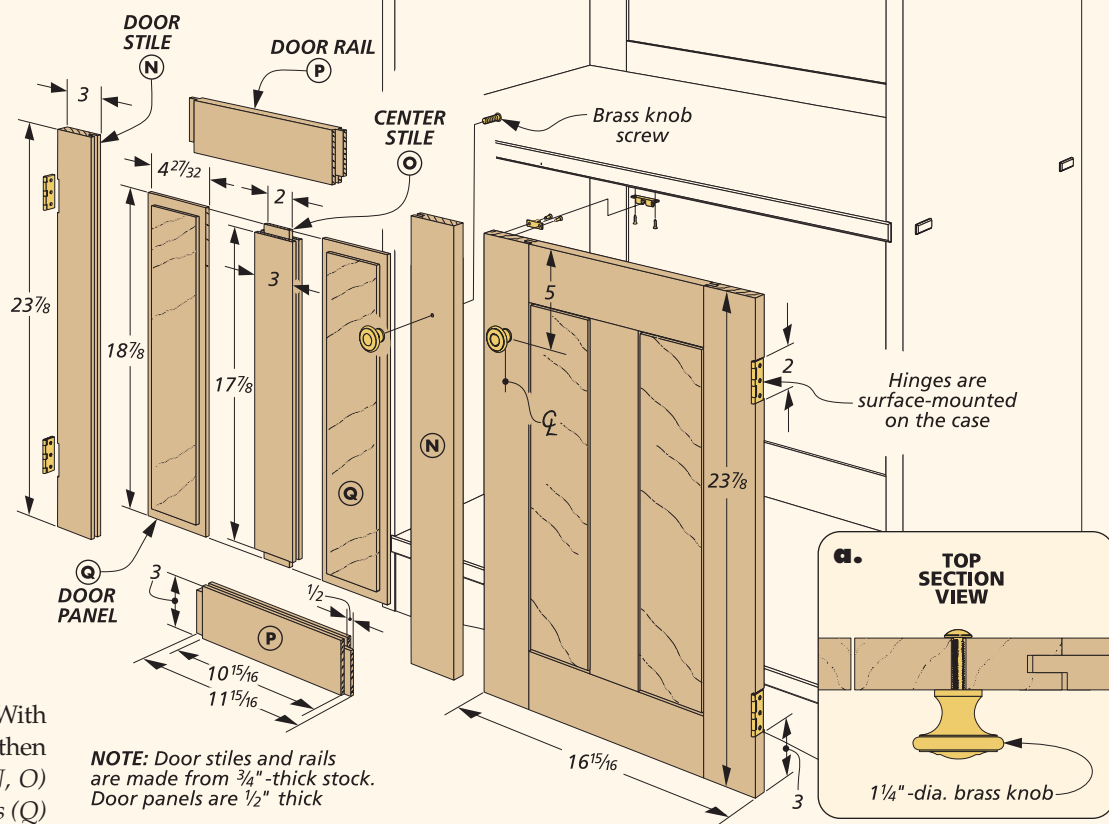

## Shop Tips: Great Panels



▲ To keep the panels centered in the doors, I placed a dot of glue in the center of the tongue and used thin spacers while gluing up the door.



▲ Staining the panels before assembling the doors prevents unfinished areas from appearing as the panels expand and contract seasonally.

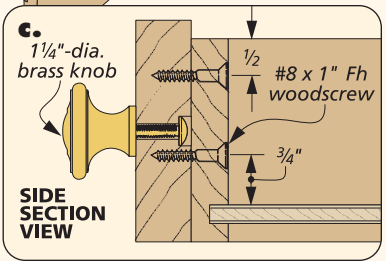
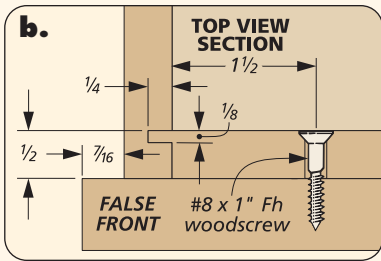
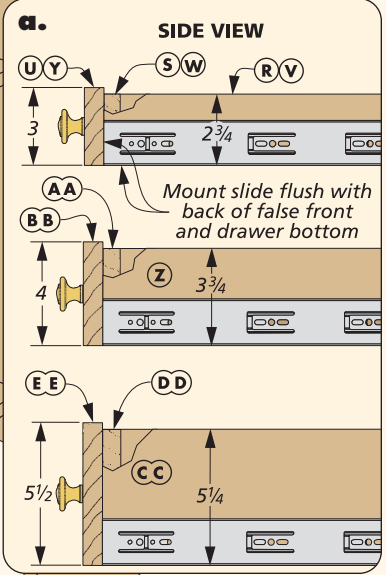
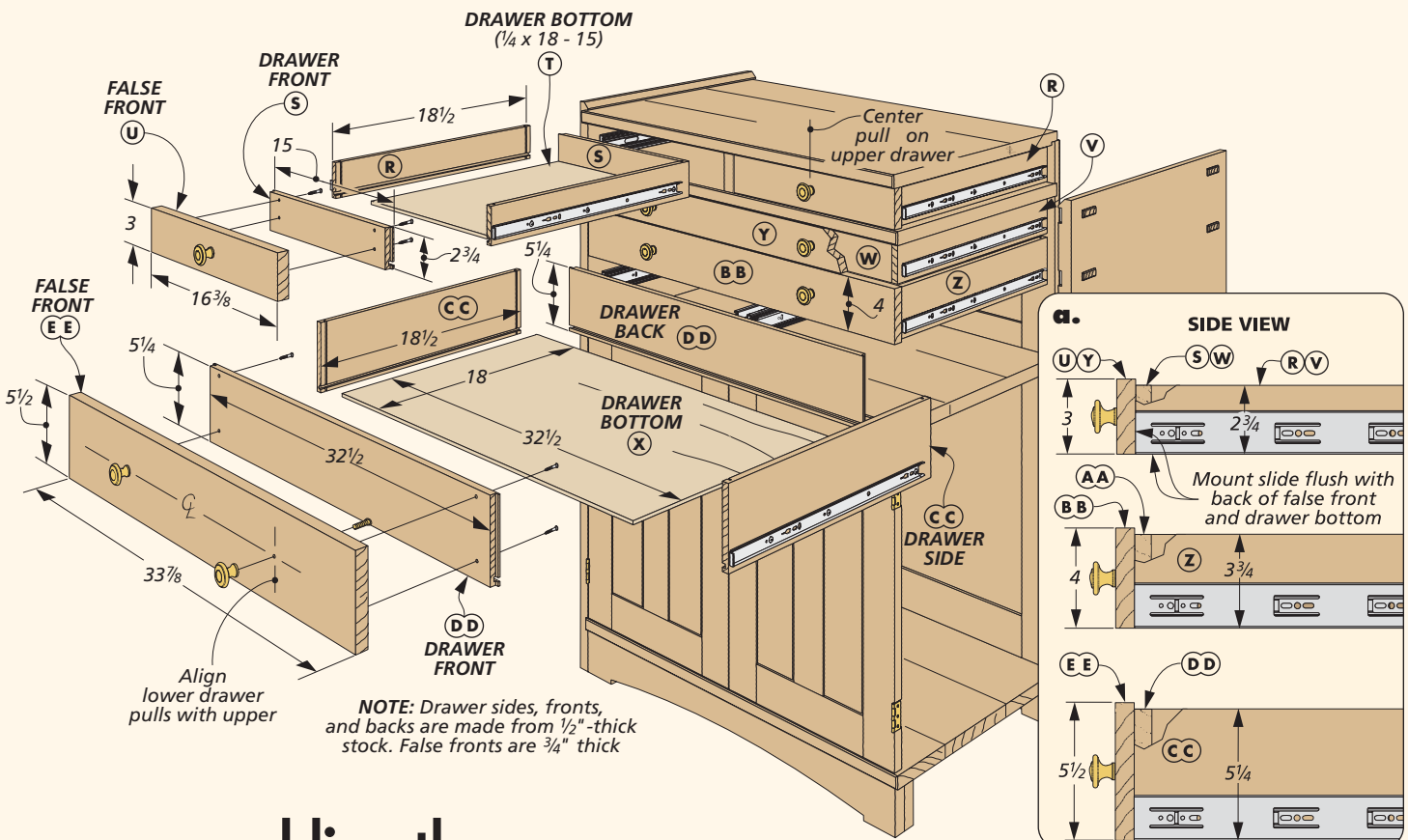

# adding the DRAWERS & TRAYS

At this point in the construction, the tool cabinet is nearly complete. All that remains is to build the drawers and trays. The upper portion of the tool cabinet contains five drawers.

The two trays divide the space behind the doors in the bottom of the cabinet (more on that later). Both the drawers and trays ride on full-extension, metal slides. While the construction is similar, there are a few differences to point out.

**SIMPLE CONSTRUCTION.** The drawing above shows how the drawers are made. Each drawer is nothing more than a shallow box with a false front. I built the box from maple and the false fronts from quartersawn white oak.

The boxes are built with simple tongue and dado joinery, as shown in detail 'b.' A dado is cut at the front and back of each side. A matching tongue is then cut on each end of the front and back.

Once the joinery is cut, you can then cut a groove on the inside face of all the parts to hold a 1/4" ply-

wood bottom. Then the drawer boxes can be glued up.

The next step is to attach the drawer slides. The full-extension slides come in two parts. One part is screwed to the side of the case. The second part is attached to the bottom edge of the drawer box.

**FITTING THE FALSE FRONTS.** Once the drawers are in place, I made and attached the false fronts. I wanted to end up with a 1/16" gap on all four sides (to match the doors) so I cut the false fronts slightly oversize and trimmed them to fit the opening. The photo at left shows a simple way to position the false fronts. When the false front is in the right spot, the tape holds it in place for drilling the screws holes, as shown in the tip at left. The last thing to do before attaching the false fronts, is to add the pulls, as in detail 'c.'

## Shop Tip: False Front Fit



▲ A few strips of carpet tape keep the false front positioned for the proper gaps and hold it firmly in place for drilling the screw holes.



## Heavy-Duty Trays

After making the drawers, I turned next to the trays that will be installed in the lower portion of the tool cabinet. This large space is perfect for storing portable power tools. Like the drawers, each tray rides on full-extension slides. This makes it a lot easier to find something at the back of the tray. Storing heavy tools here means the trays need to be strong enough to stand up to the weight.

**BUILT FOR STRENGTH.** There are two things you can do to beef up the construction. The first is the joinery. For the trays, I used a locking rabbet. In detail 'a,' you can see that the sides, front, and back interlock to create a joint more rugged than a tongue and dado. To make this joint, check out the three-step process that you see below.

The second thing you can do to beef up the trays is to strengthen the materials. Here I did two things. The first is to make the front and back from  $\frac{3}{4}$ "-thick hard maple instead of  $\frac{1}{2}$ " material. The other thing I did was beef up the  $\frac{1}{4}$ " plywood normally used for drawer and tray bottoms.

To reinforce the tray bottom, I made it out of a double layer of  $\frac{1}{4}$ " plywood. The first layer is glued into a  $\frac{1}{4}$ " groove cut in the tray sides, front, and back. The second layer is then cut to fit underneath

the first, as shown in detail 'b.' This makes the tray bottom much more rigid and less likely to flex under a heavy load of tools.

**MOUNTING THE TRAYS.** Finally, I installed the trays. In order for the

trays to clear the doors, they're mounted to a pair of spacers (detail 'c'). The spacers are attached with screws and washers in oversize, counterbored holes to allow the case to expand and contract. **W**

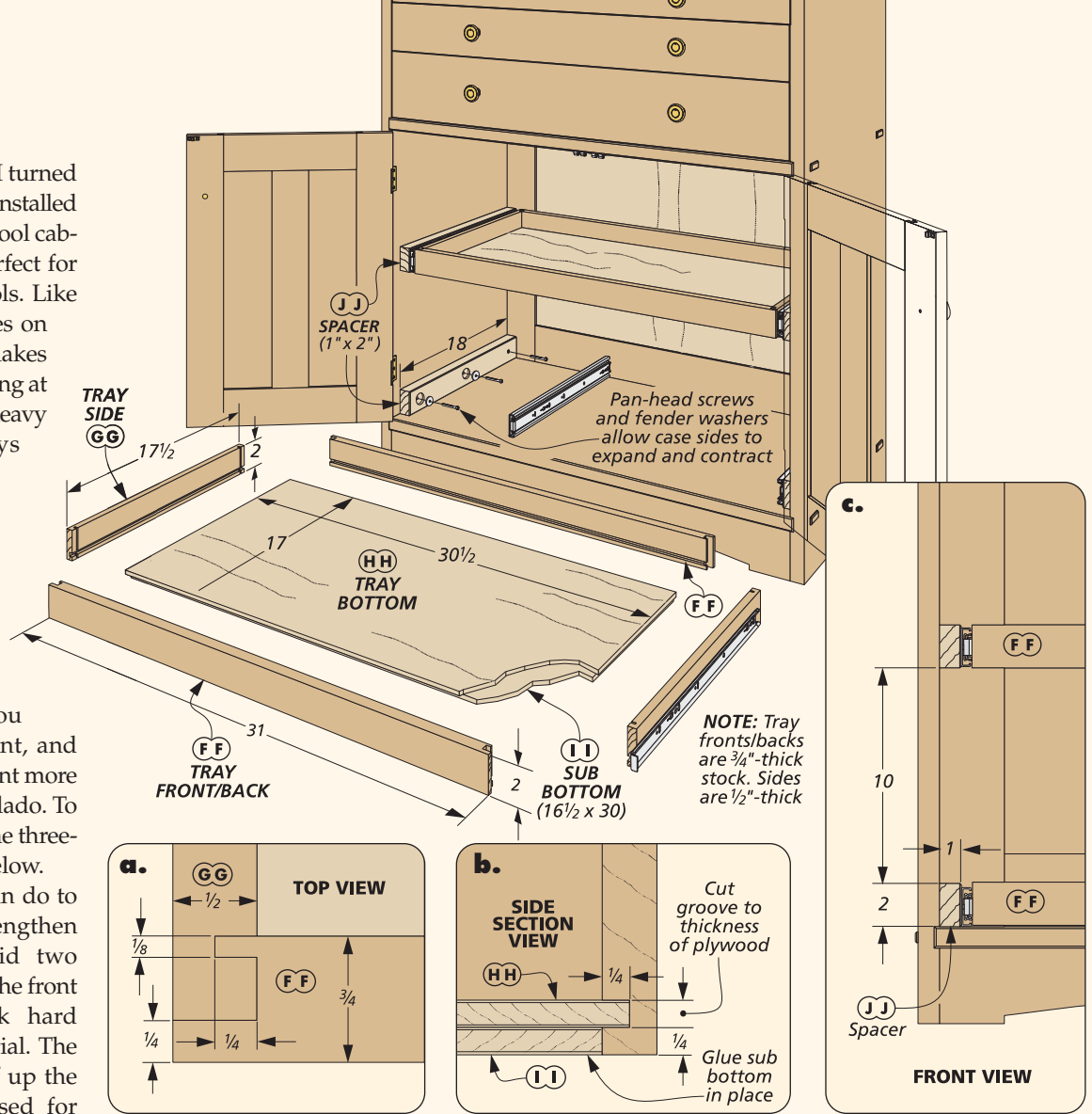

## How-To: Locking Rabbet Joint

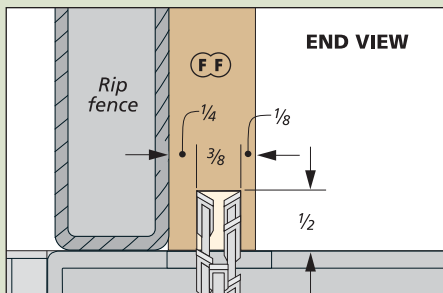

**Slot.** To make a locking rabbet, start by cutting a slot in each edge of the front and back. The depth of the slot should match the thickness of the sides.

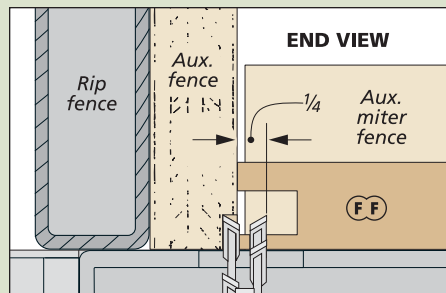

**Tongue.** Next, cut the inside tongue of the slot back. I set the rip fence as a stop and supported the workpiece with an auxiliary fence on the miter gauge.

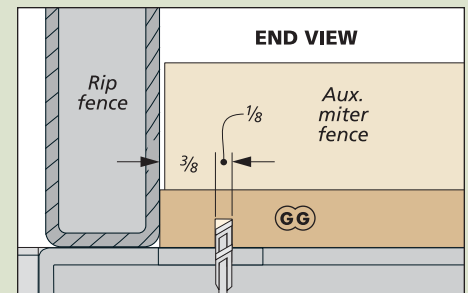

**Dado.** The final step is to cut a dado in the side pieces. The dado should match the tongue on the front and back. The remaining tongue should just slip inside the slot.



# FINE TOOL CHEST

It's the perfect place for your best hand tools and works great alone or sitting on the tool cabinet.

When it comes to keeping and organizing my favorite hand tools, I wanted to make a special case for them. So I built this tool chest. You can build it to sit on top of the tool cabinet shown on page 34, or your

workbench. The construction of this chest is very similar to the tool cabinet — just on a smaller scale, as in the exploded view below.

**BUILDING THE CASE.** To build the tool chest, I started by assembling the

case. The  $\frac{1}{2}$ "-thick top, bottom and divider are joined to the chest sides with  $\frac{3}{16}$ "-deep dadoes.

A pair of stopped dadoes in the top and divider hold drawer dividers for three narrow drawers. They're notched at the front so that they'll sit flush with the sides, as in the exploded view. The horizontal parts all have a small chamfer cut on the front edges to match the chamfer on the top of the sides.

The frame and panel back of the tool chest is glued into a stopped

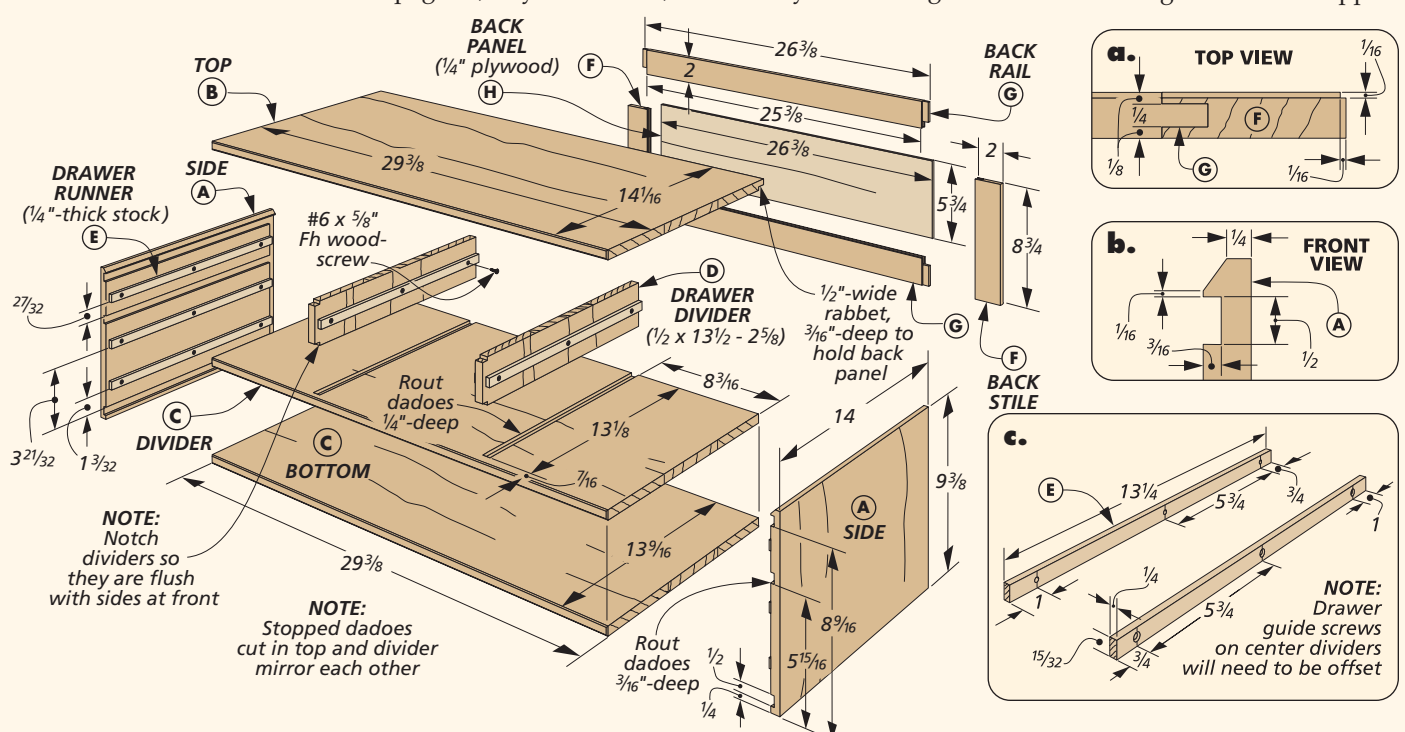

rabbit cut in the case sides. A small rabbit cut on the outside edges of the frame creates a shadow line, as in detail 'a' on page 42.

Before the case can be assembled the drawer runners should be installed, as in detail 'c' on the opposite page. The openings are too small to do this after the case is glued up. The last piece to install on the case is a small *filler strip* (I) under the bottom (drawing at right).

### BUILDING THE DRAWERS

The five drawers in the tool chest are much smaller than those in the larger tool cabinet. Because these drawers are small, I didn't use false fronts. Here, the drawer fronts are made from oak and the sides and backs of the drawers are made from maple, since only the drawer front is visible when it's closed.

The drawers are shallow so that everything inside is in plain sight when I open a drawer. However, the drawers still need to be as strong as possible. So I used locking rabbets to join the parts.

**SIMPLE JOINERY.** Since the drawers are built with the same joinery, (only the drawer part sizes are different), it makes sense to cut the joinery for the drawers, as in detail 'a' above, all at once.

Before assembling the drawers, you'll need to cut some grooves.

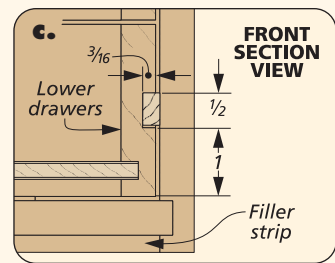
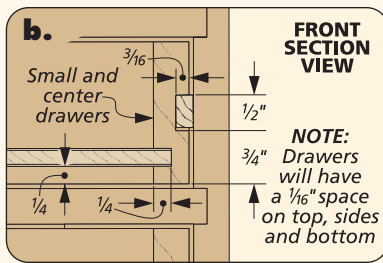
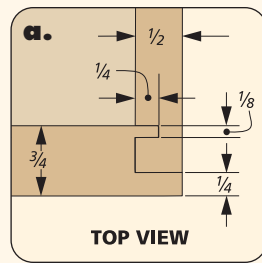
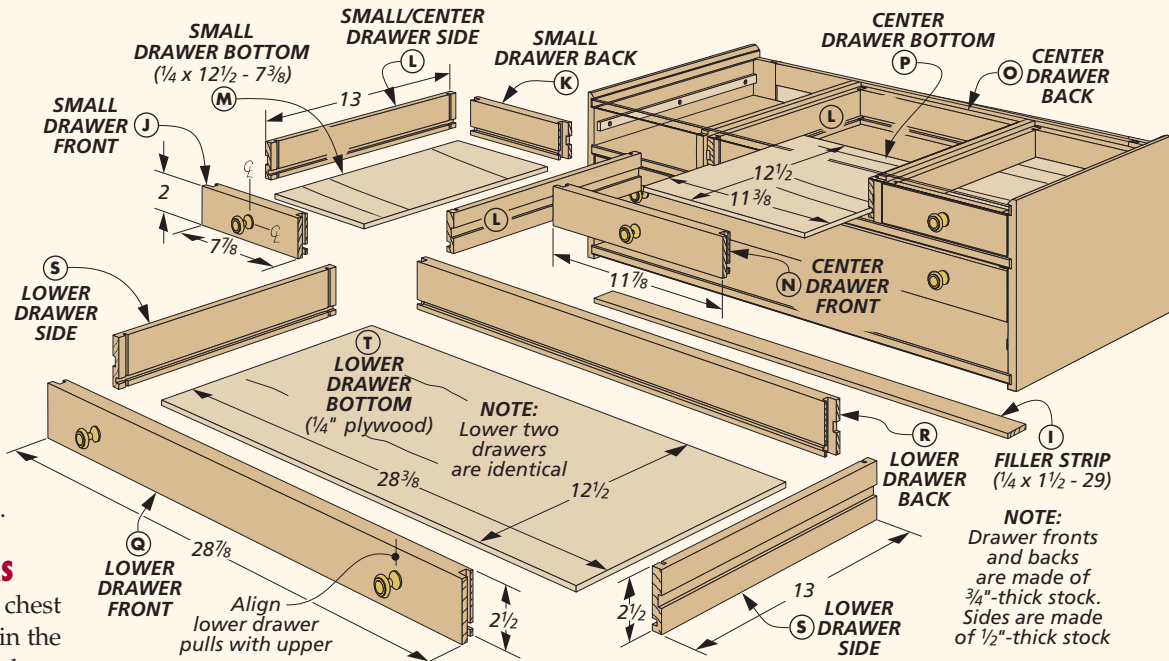

First I cut a groove on the inside face of all the parts. It's sized to hold a 1/4" plywood bottom.

A second and larger groove is cut on the outside of drawer sides. This groove will fit over the drawer runners in the case. I positioned the groove so that there is an even gap at the top and bottom, as in detail 'b.' To do this, I cut a few test pieces so that I could check the setup.

Once the grooves are cut, you can go ahead and cut the drawer bottoms and glue up the drawers. There's just one more thing to do. You'll need to notch out the drawer back so that the drawers will fit over the runners. You can see how I did this in the drawing below.

Finally, I added the brass pulls. They're a smaller version of the knobs I used on the tool cabinet. **W**



**Drawer Guides.** The drawers in the tool chest slide on wood runners mounted in the case. The runners fit in grooves cut on the drawer sides. A little wax will make them slide even smoother.

## How-To: Wood Drawer Guides

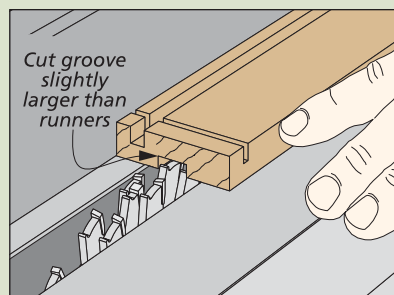

**Groove.** After cutting the joinery for the drawer parts, I cut a groove in the drawer sides. The groove is sized slightly larger than the runner.

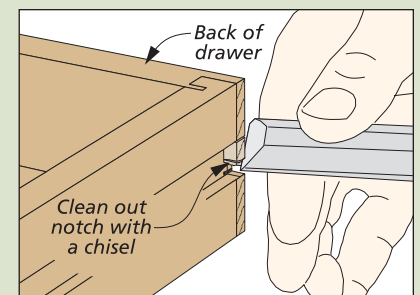

**Notch.** To allow the drawer to slide onto the runner, you'll need to cut a notch in the drawer back. I used a hand saw and a chisel to do this.

# 5 tools that will Change the Way You Work



▲ A hollow-chisel mortiser makes quick work of cutting square, accurate mortises in one step.

## 1 Hollow Chisel Mortiser

Over the years, we've cut quite a few mortise and tenon joints for the projects you see in the magazine. To make the mortises, I usually use a drill press and Forstner bit to drill them out. Then I clean the sides and ends with a chisel. It's a simple, reliable method. But if there are a lot of mortises to cut, this technique can be a bit time consuming.

With a hollow-chisel mortiser, you can cut half of this traditional joint much quicker. Quite simply, a

hollow-chisel mortiser makes cutting mortises an accurate, one-step operation. Start by setting the fence and workpiece hold-downs. Then all you have to do is drill a series of "square" holes to define the mortise. Since, there's little or no clean up afterward, cutting mortises takes less time with a lot less hassle.

Best of all, these tools are becoming more affordable. So if you cut a lot of mortise and tenon joints, you may want to pick up one of these machines.

## 2 Biscuit Joiner

Some tools, like the mortiser shown above, make woodworking tasks faster and easier. But others, like a biscuit joiner, can change the way you design and build a project altogether.

With most joinery methods, you need to factor in the joinery when sizing parts. But with biscuit or plate joinery, you just cut the parts as if they were going to be butt jointed and the biscuit joiner takes care of the rest. The joiner cuts a shallow slot in each of the mating edges of the workpieces. A short, compressed wood "biscuit" is then glued in the slots. The biscuit acts like a spline to hold the two parts together.

Biscuit joinery is a fast, accurate, and easy way to build cabinet cases. But you'll probably find a lot of other uses for it too — like building face frames, attaching fixed shelves, or reinforcing miter joints, as illustrated in the photo at right.



▲ A biscuit joiner makes assembling projects fast and easy. Designing is easier too, since parts are cut to finished size without having to account for joinery.

### 3 Brad Nailer

I get impatient waiting for glue to set up while attaching trim molding to a project. It seems to take forever before you can take the clamps off and move on. That's why it's nice to have a brad nailer around. Not only does it speed up assembly time, but it's faster than trying to pound in brads with a hammer.

Don't get me wrong. I'm not about to throw out my clamps or use nails on every project. But a brad nailer can do some jobs better and faster than using clamps or a hammer and nails.

For instance, installing molding. Who hasn't had a hammer slip and ding a workpiece? Brad nailers are

great for applying molding, as you can see in the photo at right. Thin molding can be hard to hold in place with clamps and the delicate profiles can be easily damaged. But with a few well-placed brads, all you have are a few tiny holes to fill.

A brad nailer will come in handy for more than just pinning molding in place though. You can use it to quickly build a jig — or even shop cabinets — and get right back to work. Once expensive, you can now find top-notch nailers packaged in kits that include an air compressor and all the accessories you need at many hardware stores and home centers.



▲ Speed and accuracy are the name of the game with a brad nailer. You'll spend less time assembling projects, and use fewer clamps with one of these in your hand.



▲ Whether it's routing hinge mortises, chamfers or simple roundovers, a trim router is never far from my workbench.

### 4 Trim Router

The first time I picked up a trim router, it seemed more like a toy than a "real" woodworking tool. Too small. Too wimpy. But after using one for a while, you couldn't tear it away from me.

So what makes these pocket-sized routers so great? First off, they're the perfect size for routing those final details on a project like chamfers and roundovers. I can even do it one handed (not something I'd try with a full-size router).

On small decorative details, you're not removing a lot of material so lots of horsepower isn't too

important. And it's easier to control a small trim router than trying to balance a larger, full-size router. I usually keep a roundover or chamfer bit in the trim router ready to go at a moment's notice. This way, I don't have to take extra time messing around with changing bits on my full-size router.

Another job where a trim router really comes in handy is routing a hinge mortise, as shown in the photo at left. The small size and greater control of the trim router provides accurate results and less cleanup when I'm done.

### 5 Spray Equipment

When you think of spray finishing, you usually think of the great results that come from professional furniture and cabinet shops. But the truth is, you can get those same results in your shop without spending a lot of money. High-quality spray equipment is now available (and affordable) for the average woodworker.

So why would you go out and get spray equipment? Speed for one. Spray finishing is perfect for large projects. You're able to spray on several coats in the time it

would take to brush on one. Best of all, it's easier to get into tight corners with a spray gun than a brush.

Spraying on finishes allows you to use fast-drying finishes that are problematic for brushing. But what I like best are the consistent results. A good sprayed-on finish is flatter and more even without leaving any tell-tale brush marks.

If you're like me, you'd rather be building a project than applying finish. So investing in some spray equipment will get you back to the shop building projects sooner. **W**



▲ A basic spray system and fast-drying finishes make quick work of finishing large projects.

**finishing** room

never-fail

# Oil and Wax Finish

When you can't face the finish, call on linseed oil and paste wax to do the job.



▲ The supplies you'll need to gather for an oil and wax finish couldn't be much simpler. And applying the finish won't send you into a panic.

I think every woodworker has, at one time or another, felt the "fear of finishing." You take the last clamp off of a project and it looks great, but you just know the finishing gremlins are waiting to mess up your hard work. Well, when you find yourself in this situation, I have an answer. Treat yourself and your project to a boiled linseed oil and wax finish.

An oil and wax finish is about as foolproof as any finish can get. As you'll see, it's so easy you can practically apply it in your sleep. And the bonus is the thin protective film you create lets the natural beauty of the wood shine through.

**TWO PARTS.** The secret to an oil and wax finish is how the two parts work together. First, the boiled linseed oil soaks into the wood to give it a warm glow and create a thin

protective layer. The color and figure of cherry, walnut, maple, and even oak will really "pop" after just a single coat of linseed oil.

But the oil alone has no shine. And that's where the wax enters the picture. A thin coat of paste wax rubbed on over the oil and then buffed out will add another layer of protection and leave a soft sheen that can't be beat.

## **GIVE IT A GO**

Applying an oil and wax finish couldn't be much simpler. But like anything, there are a few tricks to it.

**SMOOTH SURFACE.** Since an oil and wax finish is very thin, what you see on the surface of the wood is what you get. This means you need to start with a really smooth surface. And all this takes is some

thorough sanding (220 grit does the job). And when I set down the sandpaper, I give the project a good going over with a tack cloth.

**WIPE ON THE OIL.** Now the “easy” work begins. Dip a pad of #0000 steel wool into a jar of boiled linseed oil and start rubbing it into the wood (top right photo). A soft cloth will also do the job, but I prefer steel wool. It holds the oil well and its fine, abrasive action allows me to really work the oil in.

You want to flood the surface with the oil and then rub it in with a vigorous circular motion. When the project is thoroughly covered you can relax for a bit. Give the oil 10 or 20 minutes to soak into the wood. As this happens, you’ll start to see the surface dull down.

**WIPE IT OFF.** After this short wait, just take a soft cloth and wipe off any excess oil left on the surface (middle right photo). I try to be pretty thorough and get into all the corners and recesses.

**MORE OIL.** If conditions are good (dry and warm), the oil will be dry enough to recoat in a day. If the surface still feels tacky, wait a little longer. First, give the piece a quick rubdown with #0000 steel wool and then wipe on a second coat just like you did the first.

On the third day, you guessed it, more oil. You still won’t notice much build or sheen but that’s not what you’re after. You want the oil to soak in, not lay on the surface.

**TIME FOR WAX.** After the third coat of oil is dry, it’s time to bring up the shine with a coat of good quality furniture wax (I use a beeswax and carnauba blend like the *Briwax* shown in the lower right photo.)

The wax can go on with either a soft cloth or steel wool (bottom right photo). But unlike the oil, you want to apply the wax a little more sparingly. Just enough to leave an even layer on the surface.

The wax dries quickly. About as soon as you finish wiping it on, you start to buff it out with a soft cloth, or even better, a piece of lamb’s wool (top left photo). You’ll need to use a pretty vigorous circular motion for this job. The surface will feel a little tacky at first, but the more you rub, the easier your “buffer” will slide across the surface. And this is when you’ll see the magic. The surface of the wood will come to life and take on a subtle, soft sheen. When your buffer no longer grabs and the surface has an even sheen, you’re done.

Now you might wonder how well such an easy-to-apply, thin finish will hold up. Well, for projects that don’t get a lot of heavy wear and tear, I’ve found that it’s plenty durable. And a big plus is that, unlike thick film finishes, an oil and wax finish can be quickly repaired. To remove a scratch or watermark, simply rub off the wax with steel wool, sand if necessary, and repeat the simple process. **W**



▲ A jar of oil and a pad of steel wool are all you need to get started. Wipe on a heavy coat and let it soak in.



▲ The second step is just as easy. After giving the oil time to soak in, wipe off any “leftovers” with a soft cloth.



▲ A light coat of paste wax goes on over the third coat of oil. A soft cloth and a circular motion do the job.

## One-Step Oil and Wax Finish

A while back, I came across an interesting recipe for an “all-in-one” oil and wax finish. Always on the lookout for new finishes, I decided to mix up a batch and give it a try.

This simple mixture called for equal parts (by volume) of three of the oldest finishing materials in the book — boiled linseed oil, turpentine and beeswax. You can melt the beeswax in a double boiler and add it to turpentine, but I just

shaved pieces off a block and let it dissolve overnight. After adding the linseed oil, you’ll have a mixture that looks a bit like varnish.

Apply the mixture just like you would straight linseed oil — wipe it on and then wipe off the excess. After several coats, you can buff out the surface. I found that you only get a low sheen from this mix, but it has a nice look and the process sure was easy.



# Questions & Answers

## Drilling and driving screws into MDF

**Q** When working with MDF, I find that woodscrews can split the workpiece or cause a noticeable bulge. How can I prevent this?

Charlie Scheffel  
Lyons, Illinois

**A** The shank of a typical woodscrew is shaped like a wedge. So the problem is that unless the shank hole and pilot hole are drilled just right, the screw can split the workpiece (left drawing below). But I've found that simply

switching to a different fastener and using a simple, three-step drilling technique can help make the entire process virtually foolproof.

**SHEET METAL SCREWS.** Instead of traditional woodscrews, I like to use sheet metal screws (see right drawing below). Since the whole shank is straight, it isn't as likely to split the MDF.

Note: For extra holding power, I use screws that are  $\frac{1}{2}$ " to  $\frac{3}{4}$ " longer than I would typically use for joining solid wood or plywood.

**DRILLING THE SHANK HOLE.** For the sheet metal screws to securely fasten the parts together, you'll need to size the shank and pilot holes accurately. The key to drilling the shank hole is to size it so the screw pulls the top piece

down tightly to the bottom piece.

To do this, I find a bit that's slightly larger than the outside diameter of the threads. This way, the screw will just slip through the hole.

**A COUNTERSINK.** Another problem that you'll find in driving screws into MDF is that fibers from the lower piece tend to lift up and prevent the two parts from pulling together, as shown in the left drawing below.

To solve this problem, I drill a small countersink where the shank exits the top workpiece before drilling the pilot hole, as you can see in the right drawing. The countersink provides clearance for the raised fibers without affecting the fit of the two parts.

### THE PILOT HOLE.

At this point, you're ready to drill the pilot hole. The pilot hole should be the same as the inner diameter of the screw threads. This makes it easy to drive the screw, and still gives the threads plenty of bite in the workpiece.

How deep should the pilot hole be? I like to drill it just past where the tip of the screw will end up. This way, I don't have to worry about the screw splitting the MDF deep in the hole and creating a bulge in the side of the piece. **W**

## Do you have any questions for us?

If you have a question related to woodworking techniques, tools, finishing, or hardware, we'd like to hear from you.

Just write down your question and mail it to us: Woodsmith, Q&A, 2200 Grand Avenue, Des Moines, Iowa 50312. Or you can email us the question at: woodsmith@woodsmith.com.

Please include your full name, address, and daytime telephone number in case we have questions.

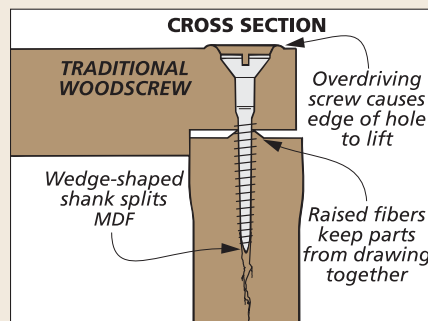

### PROBLEMS

- Woodscrew splits MDF near edges causing bulges on face of workpiece.
- Shallow countersinks and overdriving screw "lifts" edge of hole.
- MDF fibers pull away from bottom workpiece and prevent the parts from joining together tightly.

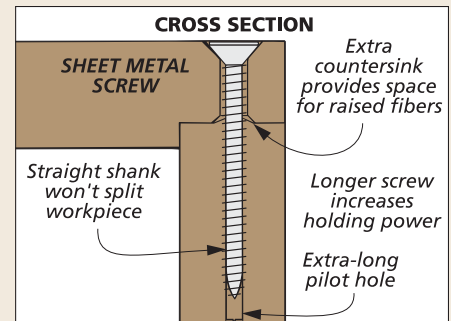

### SOLUTIONS

- Sheet metal screws and properly-sized shank and pilot holes prevent splitting and bulging of workpiece.
- Longer screws provide extra holding power in MDF.
- Countersinks at both ends of shank hole allow screw to pull joint together.





# hardware & supplies

## Sources



### ROUTER BITS

The router bits featured in the article starting on page 10 were all purchased at the *Woodsmith Store*. The lock miter bit that I tried out is made by *Freud* (#99-035). The box joint bit (#53610), the adjustable finger joint bit (#55392), and the glue joint bit (#55388) are all from *Amana*. All the bits have a 1/2"-dia. shank.

### POCKET HOLE JIGS

There are a number of pocket hole jigs on the market. Some are pretty simple and inexpensive, while others offer you quite a few bells and whistles.

The jig that I like to use in the shop is made by the *Kreg Tool Company*. Their line of pocket hole jigs ranges from basic to commercial sized. *Kreg* pocket hole jigs, screws and accessories are carried by the *Woodsmith Store*. Other sources are listed in the margin column at right.

### CRAFTSMAN TABLE

Building the tile-top Tile-Top table shown on page 16 won't take long and neither will rounding up the supplies. I suggest that you start by finding some ceramic tile that appeals to you. A home improvement store or one that specializes in tile will have a good selection.

The only other items needed are the figure-8 fasteners (#21650), available from *Rockler*, and a handful of screws.

### CLASSIC BOOKCASE

Besides being easy to build, the classic bookcase on page 24 doesn't take a lot of hardware. Other than a handful of screws, the only other hardware necessary are some leveler blocks (#31210) and a package of spoon-style shelf support pins (#22765).

If you plan on making several bookcases and connecting them, there are a couple of other items you'll need. The first is some 1 1/8"-long connector bolts (#31831). Then, to go along with these, you'll need some matching cap nuts (#31815). All these supplies came from *Rockler*. They're also available from the *Woodsmith Store*.

### TOOL CABINET & CHEST

For such a large project, the tool cabinet on page 34 doesn't really require much in the way of hard-to-find hardware. The common items (screws and washers) can be found at any good hardware or home improvement store. I ordered all of the other supplies I needed from *Rockler* and the *Woodsmith Store*.

First, you'll need seven pairs of 18"-long *Accuride* full-extension drawer slides in black (#89690). To install the doors, I purchased a nice pair of 2" bright brass butt hinges (#25767). And a couple of versatile brass ball catches (#28613) will keep the doors closed. Finally, you'll need to purchase some 1 1/4"-dia. bright brass knobs (#35485) to install on the doors and drawers.

If you decide to put your cabinet on wheels, the 5"-dia. red locking swivel casters (#31845) that I used came from *Rockler*.

To build the small tool chest, I only had to purchase a few screws and some 1"-dia. bright brass knobs (#35477).

### OIL & WAX FINISH

Another great feature of the finishing technique shown on page 46 is that all the materials are easy to come by. You can find everything at a hardware store. **W**

### Online Customer Service

Click on Subscriber Services at [www.woodsmith.com](http://www.woodsmith.com)

- Access your account status
- Change your mailing or email address
- Pay your bill
- Renew your subscription
- Tell us if you've missed an issue
- Find out if your payment has been received

## WOODSMITH PROJECT SUPPLIES

We now feature hardware from *Rockler* in many of our new project kits. To order, please use our toll-free order line, see below. It's open Monday through Friday, from 8 AM to 5 PM Central Time. Before calling, please have your VISA, MasterCard, Discover, or American Express card ready.

If you would prefer to mail in an order, please call the toll-free phone number below for more information concerning shipping charges as well as any applicable sales tax.

# Woodsmith

*on the web*

- "Online Extras" - Plans, Patterns, & More
- Over 100 Woodworking Tips Online
- Visit Our Readers' Project Photo Gallery
- Project Plans You Can Download
- Catalog of Project Kits, Tools, Jigs, & Plans
- Forums for Woodworking, Tools, & Classifieds
- Links to Other Woodworking Sites

Call us at 1-800-444-7527 or online at [www.woodsmith.com](http://www.woodsmith.com)

## MAIL ORDER SOURCES

Similar project supplies may be ordered from the following companies:

**Rockler**  
800-279-4441  
[rockler.com](http://rockler.com)

*Brass Ball Catches, Brass Knobs, Cap Nuts, Connector Bolts, Drawer Slides, Face Frame Clamp, Figure-8 Fasteners, Hinges, Leveler Blocks, Pocket Hole Jigs and Screws, Right Angle Clamp, Shelf Support Pins*

**Woodsmith Store**  
800-444-7527

*Amana Router Bits, Cap Nuts, Connector Bolts, Drawer Slides, Face Frame Clamp, Figure-8 Fasteners, Hinges, Kreg Pocket Hole Jigs, Leveler Blocks, Pocket Hole Screws, Right Angle Clamp, Shelf Support Pins*

**Amana Tool**  
800-445-0077  
[amanatool.com](http://amanatool.com)  
*Router Bits*

**Woodworker's Supply**  
800-645-9292  
[woodworker.com](http://woodworker.com)

*Brass Knobs, Drawer Slides, Keller Dovetail Jigs, Tabletop Fasteners, Router Bits*

**Kreg Tool Company**  
800-447-8638  
[kregtool.com](http://kregtool.com)

*Face Frame Clamp, Pocket Hole Jigs and Screws, Right Angle Clamp*

**Woodcraft**  
800-225-1153  
[woodcraft.com](http://woodcraft.com)

*Drawer Slides, Face Frame Clamp, Figure-8 Fasteners, Pocket Hole Jigs and Screws, Right Angle Clamp*

# details of craftsmanship

## cabinet construction that's **Built to Last**

Learn the time-tested techniques to frame & panel construction in solid wood.

Wood moves. That's a fact. No matter what you do, it's going to expand and contract with seasonal changes in humidity. So when building cabinets in solid wood, you need to account for wood movement in the design of the project and the joinery you use to build it.

### **FRAME AND PANEL.**

One traditional way to deal with wood movement is to use frame-and-panel construction. Here, a solid-wood panel

is wrapped with a flat, rigid frame. The panel fits in grooves cut in the stiles and rails of the frame. But it isn't glued in place. Instead, the panel is cut a bit narrower than the opening and allowed to "float" in the grooves. This gives the panel a little breathing room to expand and contract without affecting the rest of the assembly. Don't get me wrong, the stiles and rails still do move. But since the parts are narrow, this doesn't amount to much.

**RUGGED JOINERY.** What this means is that the frame and its joinery are the key to keeping the assembly flat and rigid. The joinery has to have a lot of glue surface to be

strong enough to resist twisting and sagging (in the case of doors).

When deciding on what type of joinery to use, there are a couple of things to think about — the size of the frame and panel and its function. For example, the joinery on the small sides of a cabinet doesn't need to be as strong as the joinery for a large door. Depending on the project, I'll pick one of two joinery techniques — a stub tenon and groove or a mortise and tenon.

### **STUB TENON & GROOVE**

The joint I use on small projects is the stub tenon and groove, as shown in the top drawing on the opposite page. And it's the direction we took when building the coopered door



cabinet. The cabinet sides are supported by the top, bottom, and back so they aren't under a lot of stress. What makes this joint perfect for this situation is that it provides a good amount of glue surface and it's easy to cut on a table saw.

**GLUE SURFACE.** For the strongest joint, I cut the grooves 1/2" deep. The stub tenons are then cut to fit. This gives you enough long-grain glue surface to create a surprisingly strong, long-lasting joint.

**FITTING THE PANEL.** There's one other thing to mention here. The stub tenons should fit snugly in the grooves, but the tongues on the panel should fit a little looser. You want the panel to fit tight enough so it doesn't rattle, but yet still move freely with changes in humidity. (To see a few ways to secure the panel and keep it centered, take a look at the box below.)

### MORTISE & TENON

A stub tenon and groove works fine for small panels. But what about larger case sides and doors?

In these situations, the frame-and-panel assemblies may be unsupported (like a door) or be subject to more weight and greater abuse. To handle that, you'll want to beef up the joinery.

That's when I turn to the second joint — a mortise and tenon. This joint has a number of things going for it that makes it ideal for solid-wood construction. If you take a look at the lower drawing at right, you can see what I'm talking about.

**BUILT FOR STRENGTH.** Like the stub tenon and groove joint, the panel is captured by grooves in the frame. But instead of relying on the stub tenons and grooves to hold the frame together, a deep mortise is cut on each end of the stiles and a matching tenon is cut on each end of the rails. This gives the frame a large glue surface that makes a big difference in keeping the frame rigid and square.

**INTERLOCKING JOINT.** A mortise and tenon joint provides a strong physical connection too. The shoulders of the tenon resist racking and twisting perfectly for large doors. And the interlocked parts can't slip apart and are able to support a lot of weight.

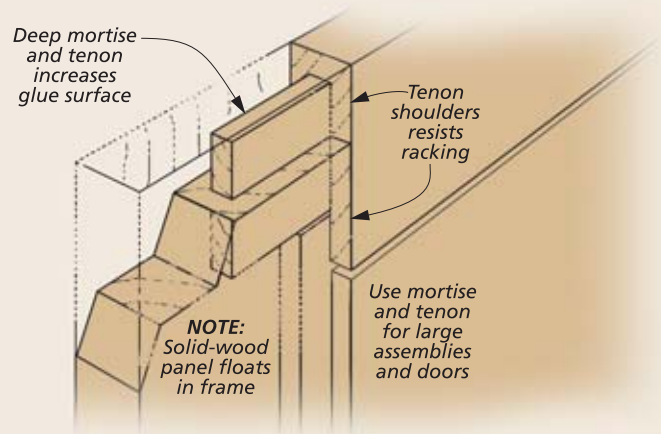
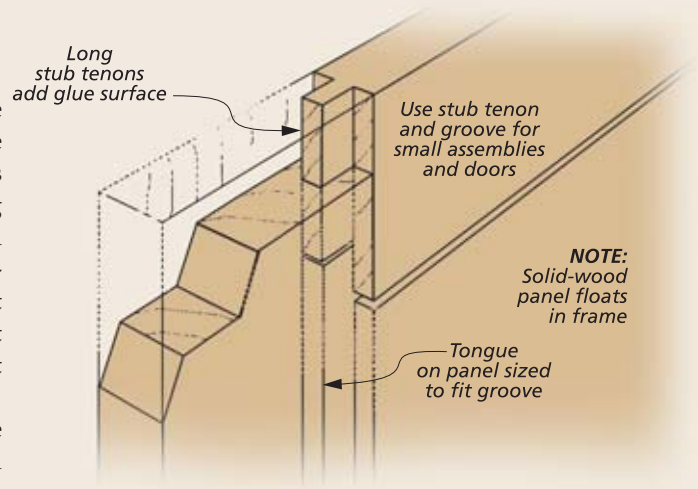

So all it takes are two basic joints and an understanding of how wood moves, to build strong, flat frames that will stay flat for decades to come. **W**

## Shop Tip: "Locking in" Loose Panels

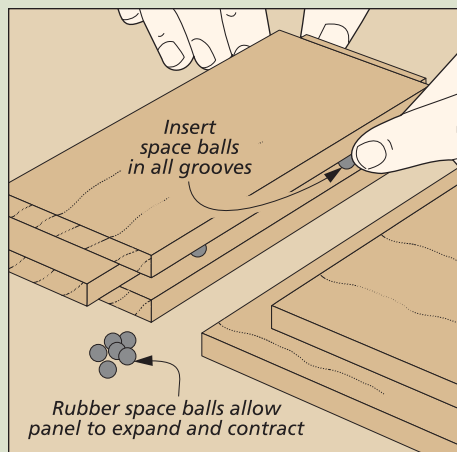

**Space Balls.** Place these soft, rubber balls in the grooves of the panel before assembly. They're firm enough to hold the panel in place, but soft enough to allow movement.

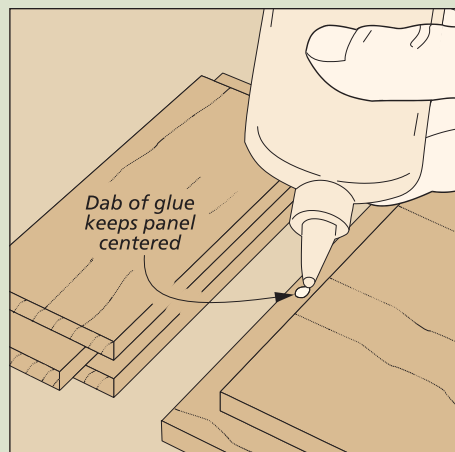

**A Dab of Glue.** Although you can't glue the entire panel in the frame, a "dab" of glue centered on the top and bottom of the panel will keep it from shifting around.

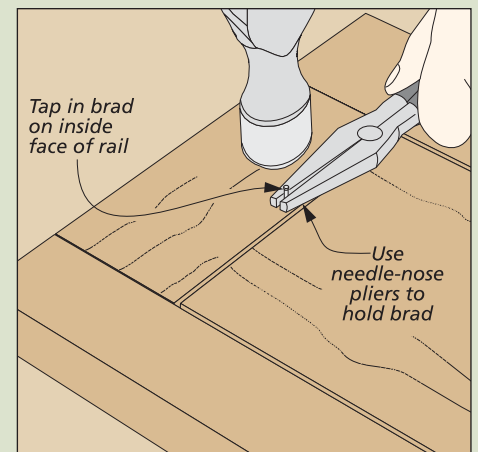

**Wire Brad.** Start by gluing the frame together. Then drive a brad through the top rail on the inside (so it won't be visible) to keep the panel centered.

# looking inside

## Final Details



◀ *Classic Bookcase.* Start with straightforward construction and traditional moldings. Then add an expandable design that makes it just as easy to build a single section or a whole wall of storage. Step-by-step plans start on page 24.

▼ *Tool Cabinet.* Of course, a tool cabinet needs to be solidly built and have tons of storage space. But this heirloom cabinet looks great too. It's built from oak and features a unique joinery technique. By adding some casters and a pair of mounting boards, you can make it mobile. Detailed plans begin on page 34.



▲ *Tile-Top Table.* This great-looking accent table uses rock-solid mortise and tenon joinery, and features a functional and stylish tile top. The complete instructions begin on page 16.

