



Wow! I Made It.com

## **A**dirondack Sofa

*We have made many Adirondack chairs over the years and thought it would be neat to have one that was just a bit larger. So this time we built a good-sized bench. Whether you share the bench with a friend or stretch out on it all by yourself, you will enjoy the traditional Adirondack shape.*



## **Special Tools and Techniques**

- C-clamp
- Bar clamp (optional)

## **Materials and Supplies**

- 30 linear feet of 1 x 6 pine
- 56 linear feet of 1 x 4 pine
- 5 linear feet of 1 x 2 pine
- 5 linear feet of 2 x 4 pine

## **Hardware**

- 50, 1-5/8" wood screws
- 60 1-1/4" wood screws
- 15, 1-1/4" (3d) finish nails
- 4 carriage bolts, 3/8" x 2" with washer and nut
- 2 carriage bolts, 3/8" x 3" with washer and nut

## **Cutting List**

<b>Code</b>	<b>Description</b>	<b>Qty.</b>	<b>Materials</b>	<b>Dimensions</b>
A	Seat Brace	3	1 x 6 pine	39" long
B	Front Seat Trim	1	1 x 6 pine	46" long
C	Seat Side	2	1 x 4 pine	24" long
D	Seat Slat	6	1 x 4 pine	46" long
E	Back Slat	11	1 x 6 pine	32" long
F	Back Support	2	1 x 2 pine	46" long
G	Arm	2	1 x 6 pine	27" long
H	Arm Connector	1	2 x 4 pine	52" long
I	Arm Brace	2	1 x 4 pine	9" long

## **Making the Seat**

1. The trademark of the Adirondack chair is the angled seat. The braces that support the seat are simple to construct, but require exact dimensions to work. Cut three Seat Braces (A) from 1 x 6 pine, each measuring 39 inches. To achieve the necessary angles for the Seat

Braces (A) refer to *Figure 1*. Portions of the Seat Braces (A) must be cut away. This is as simple as “connect the letters.” Following the measurements in *Figure 1*, label each point, and draw a straight line from “a” to “b,” “b” to “c,” “d” to “e,” and “e” to “f”. Cut along the lines you have just drawn to eliminate the shaded portions of one Seat Brace (A), as shown in *Figure 1*. Use the resulting Seat Brace (A) as a pattern to cut the other Seat Braces (A).

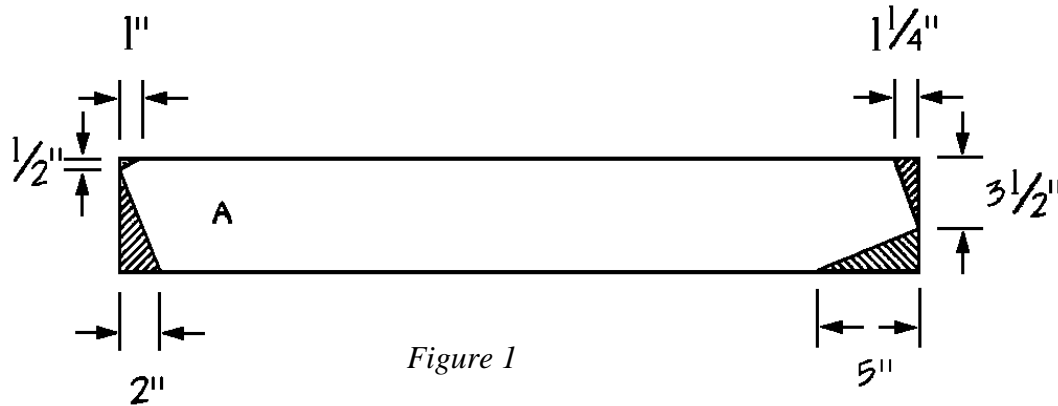

*Figure 1*

2. Cut one Front Seat Trim (B) from 1 x 6 pine, measuring 46 inches.
3. The Front Seat Trim (B) will be used to connect the three Seat Braces (A). Position two of Seat Braces parallel to each other and on edge, with the “e-f” edge facing up, 44-1/2 inches apart. Fit the Seat Trim (B) over the “e-f” edges, as shown in *Figure 2*. Nail through the Front Seat Trim (B) into the ends of the Seat Braces (A) using three 1-5/8” wood screws on each joint. Center the third brace (A) between the two far Seat Braces and screw through the Seat Trim (B) into the center brace (A) using 1-5/8 inch long screws as shown in *Figure 2*.

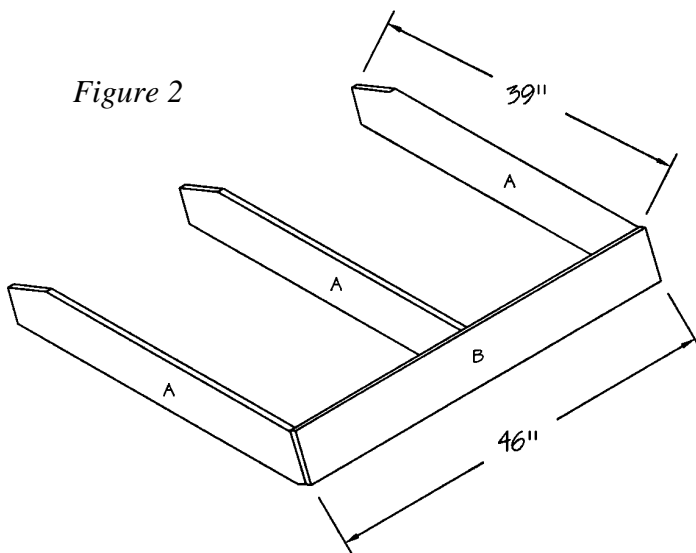

*Figure 2*

4. Cut two Seat Sides (C) from 1 x 4 pine, each measuring 24 inches.
5. Turn the assembly right side up. Follow *Figure 3* to connect the Seat Sides (C) to the Seat Braces (A), attaching them 6 inches from the top edge of the Seat Sides (C) and flush with the Seat Trim (B) on the front. Use two 2” carriage bolts to secure each of the joints, spacing them about 3 inches apart.

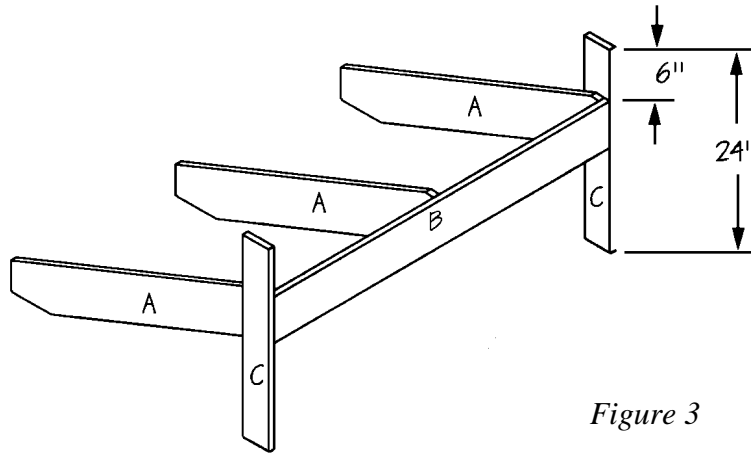

Figure 3

### Adding the Seat Slats

1. Cut six Seat Slats (D) from 1 x 4 pine, each measuring 46 inches.
2. For comfort round off the long edge of the slat (D) that will be attached to the front of the bench. Attach this slat to the “d-e” edges of the Seat Braces (A) so that it extends 1-3/8 inches over the Seat Trim (B), as shown in *Figure 4*. Use two 1-1/4” finish nails on each side, and four 1-1/4” finish nails spaced evenly across the front.
3. Attach the next four Seat Slats (D) to the Seat Braces (A), as shown in *Figure 4*, spacing them approximately 3/8 inch apart. Use two 1-1-5/8” wood screws on each joint. Attach the sixth slat (D) 2 inches from the fifth Seat Slat (D). This space will be needed later to accommodate the back of the chair.

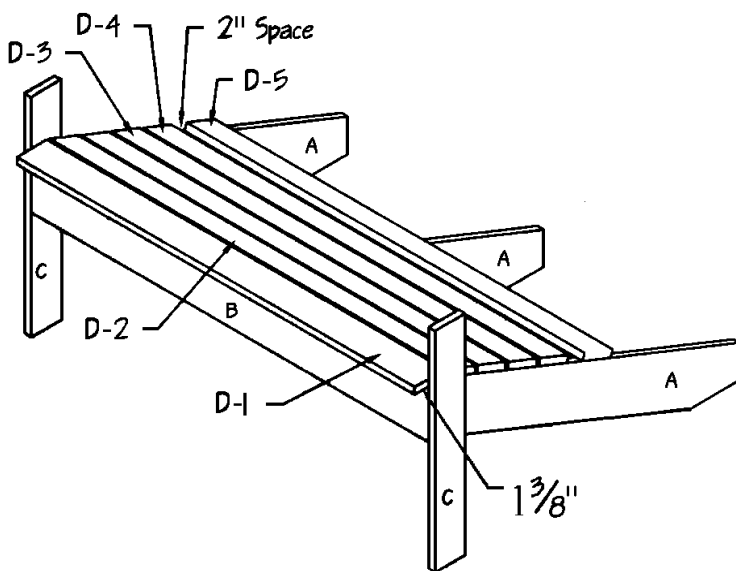

Figure 4

# Constructing the Back

- 1. Cut 12 long Back Slats (E) from 1 x 6 pine, measuring 32 inches.

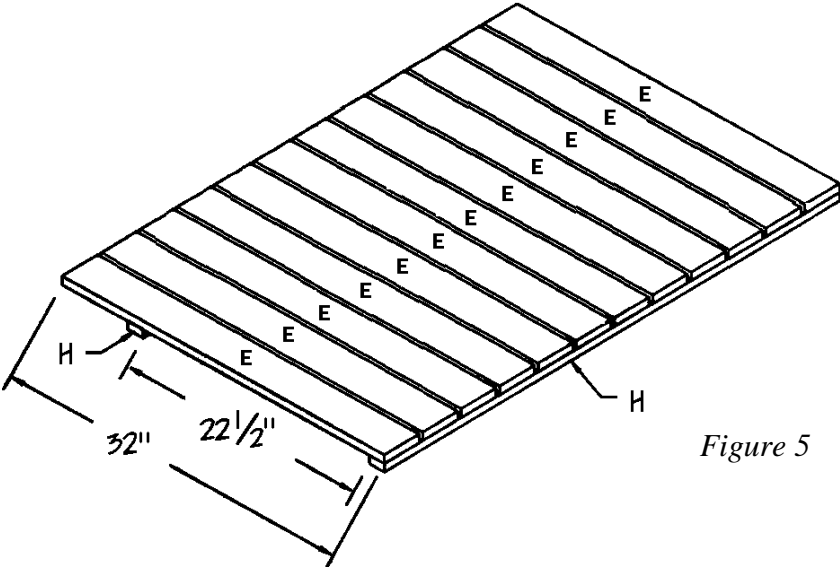

Figure 5

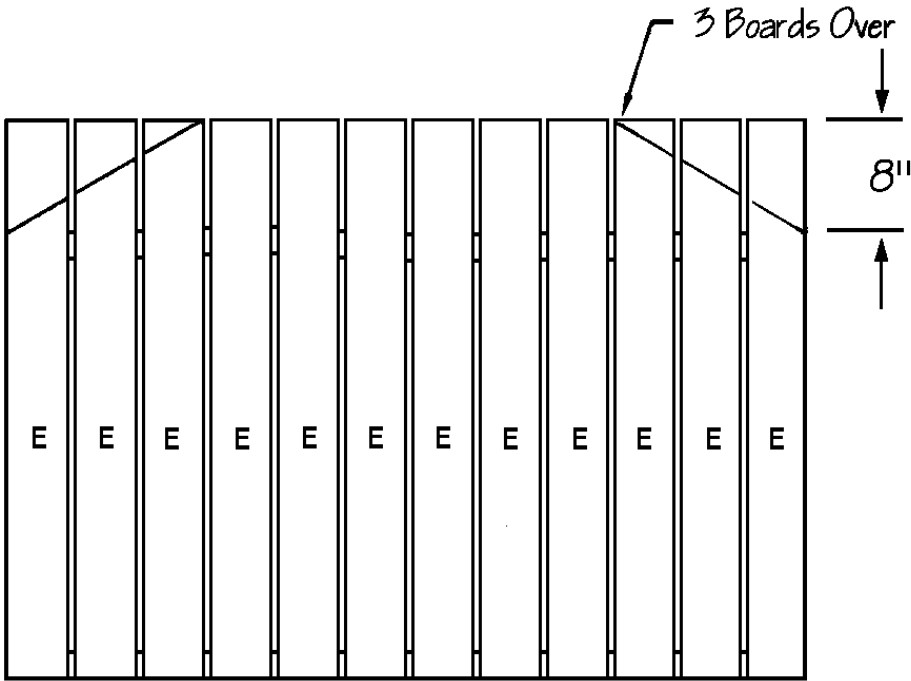
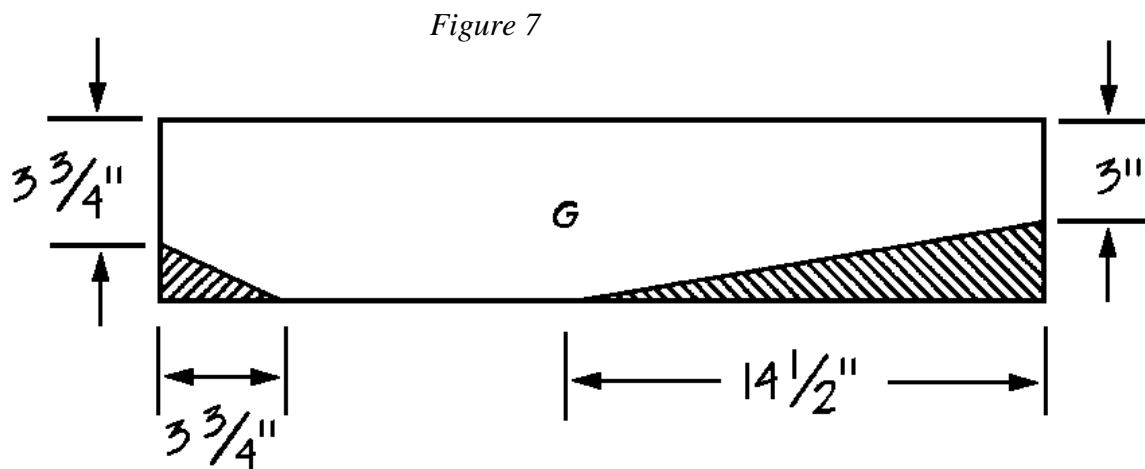

Figure 6

2. Cut two Back Supports (F) from 1 x 2 pine, each measuring 46 inches.
3. Place the two Back Supports (F) on a level surface, parallel to each other and 22-1/2 inches apart.
4. Place the 12 Back Slats (E) on top of the two Back Supports (F), spaced evenly, approximately 1/2 inch apart, as shown in *Figure 5*. Make sure that the Back Slats are square to the Back Supports (F). Note that the ends of all of the Back Slats (E) are even with one Back Support (F) at what will be the lower bench back. Screw through each of the Back Slats (E) into each of the Back Supports (F). Use two 1-1/4" wood screws at each joint.
5. Using *Figure 6* as a guide cut off the two far corners of the assembled back.

### **Constructing the Arm Assembly**

1. Cut two Arms (G) from 1 x 6 pine, each measuring 27 inches.
2. Using *Figure 7* as a guide, remove the shaded portions from one Arm (G) in the same manner you used to cut the Seat Braces (see *Figure 1*). Use this cut Arm (G) as a pattern to cut the other Arm (G).



3. Cut one Arm Connector (H) from 2 x 4 pine, measuring 52 inches.
4. In order to accommodate the back of the bench, one edge of the Arm Connector (H) must be angled. Rip the Arm Connector (H) 20 degrees along its length, as shown in *Figure 8*.
5. Place the two Arms (G) over the ends of the Arm Connector (H). Make certain that the space between the two Arms (H) is just slightly more than 46 inches in order to accommodate the back assembly. Clamp the two Arms (G) to the ends of the Arm Connector (H) using C clamps.

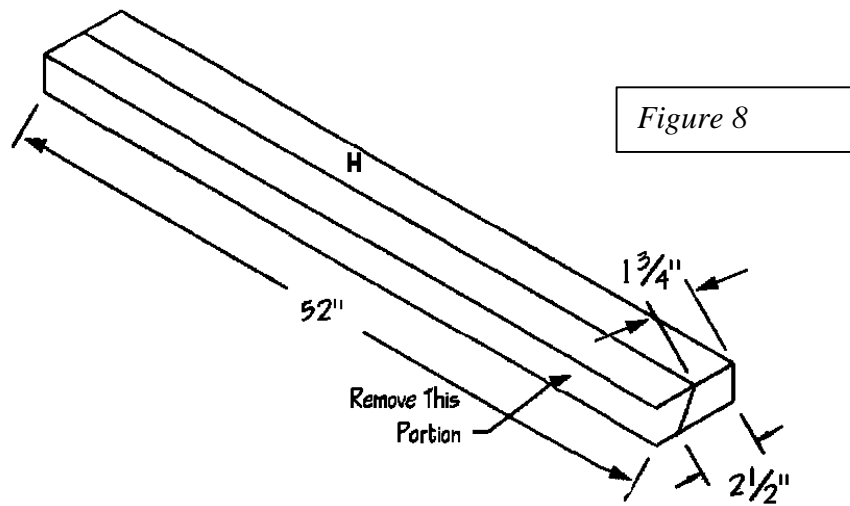

## ***Final Assembly***

1. Although you can perform this assembly with the assistance of bar clamps, it is much easier to enlist the aid of a helper. First, fit the back assembly into the 2-inch-wide gap in the Seat Slats, with the Back Slats facing the front of the bench, as shown in *Figure 9*. Then wrap the clamped Arm assembly around the back of the bench so that the front of the Arm (G) rests on the chair sides. Have the helper sit in the chair; then adjust the clamped Arm assembly so that the Arms (G) are level to the floor and the back of the chair is at the most comfortable angle. Screw through the Arms (G) to secure them to the bench sides, using two 1-1/4" wood screws on each joint. Mark the placement of the Arm Connector on the back assembly.
2. Screw through each of the Back Slats (E) into the Arm Connector (H). Use two 1-1/4" wood screws on each joint.
3. Drill a 3/8-inch-diameter hole in each Arm (G) through the Arm Connector (H), and secure the joint by inserting a 3" carriage bolt through the drilled holes. Add a washer and a nut, and tighten the bolt securely.
4. Cut two Arm Braces (I) from 1 x 4 pine, each measuring 9 inches. Using *Figure 10* as a guide, remove the shaded portion of one of the Arm Braces (I). Use the resulting piece as a pattern to mark and cut the second Arm Brace.
5. Fit the Arm Braces (I) onto the Seat Sides (C), under the Arms, with the 9" edge facing the Seat Sides (C), as shown in *Figure 9*. Screw through the Seat Sides (C) and Arms (G) into the Arm Braces (I) using two or three 1-5/8" wood screws on each joint.

Figure 9

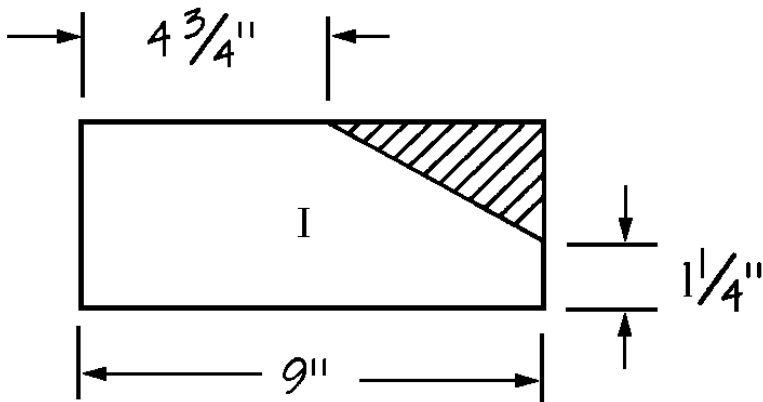
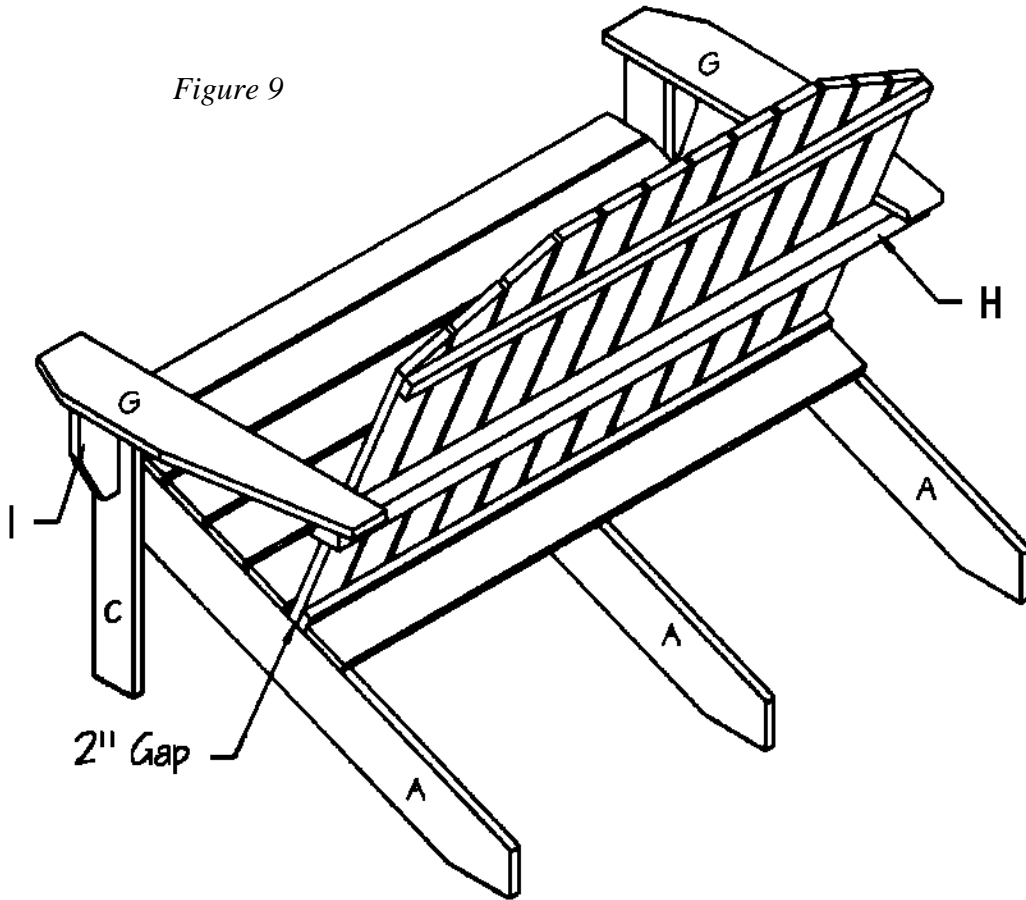

Figure 10



## ***Finishing***

1. Fill any screw holes with wood filler. Sand all surfaces thoroughly. Remember that people will be sitting on this project, so don't spare the sandpaper! No one likes splinters in the derriere!
2. You can let it weather naturally, or stain it the color of your choice.



Enjoy other indoor and outdoor projects from [www.wowimadeit.com](http://www.wowimadeit.com)!



When your friends and neighbors see your terrific backyard, they'll want to know where you got such customized outdoor furniture! Even if they're not experienced woodworkers, they'll find an easy project to get them hooked at [www.wowimadeit.com](http://www.wowimadeit.com)!