

Project 17604EZ: Chinese Tea Table

If you have a chance to visit the Portland (Oregon) Art Museum, be sure to take in the permanent display of 15th Century Mandarin wood furniture. You will appreciate the skill of these woodworkers of centuries past, and also the beautiful simplicity of the lines. No overly-ornate reproductions these, they present a clean freshness that can only be approached in modern times by Scandinavian design.

They are not, however, devoid of decorative touches sensitively applied. Mahogany solid stock was used for all parts, although maple or cherry would also be good choices.

Chinese Tea Table Materials List

Part	Description	Size	No. Req'd
A	Leg	2-1/2" x 2-1/2" x 15-3/4"	4
B	Apron	3/4" x 1-1/4" x 16"	4
C	Rail Trim	1/2" x 3/4" x 15"	4
D	Top Frame	3/4" x 2-1/2" x 20"	4
E	Web Support	1/2" x 3/4" x 5-1/4"	4
F	Web Frame	1/2" x 3/4" x 7-1/2"	4
G	Stretcher	3/4" x 1-1/2" x 17-1/2"	4
H	Glass Top	1/4" x 15-3/8" x 15-3/8"	1

Chinese Tea Table Complete Schematic

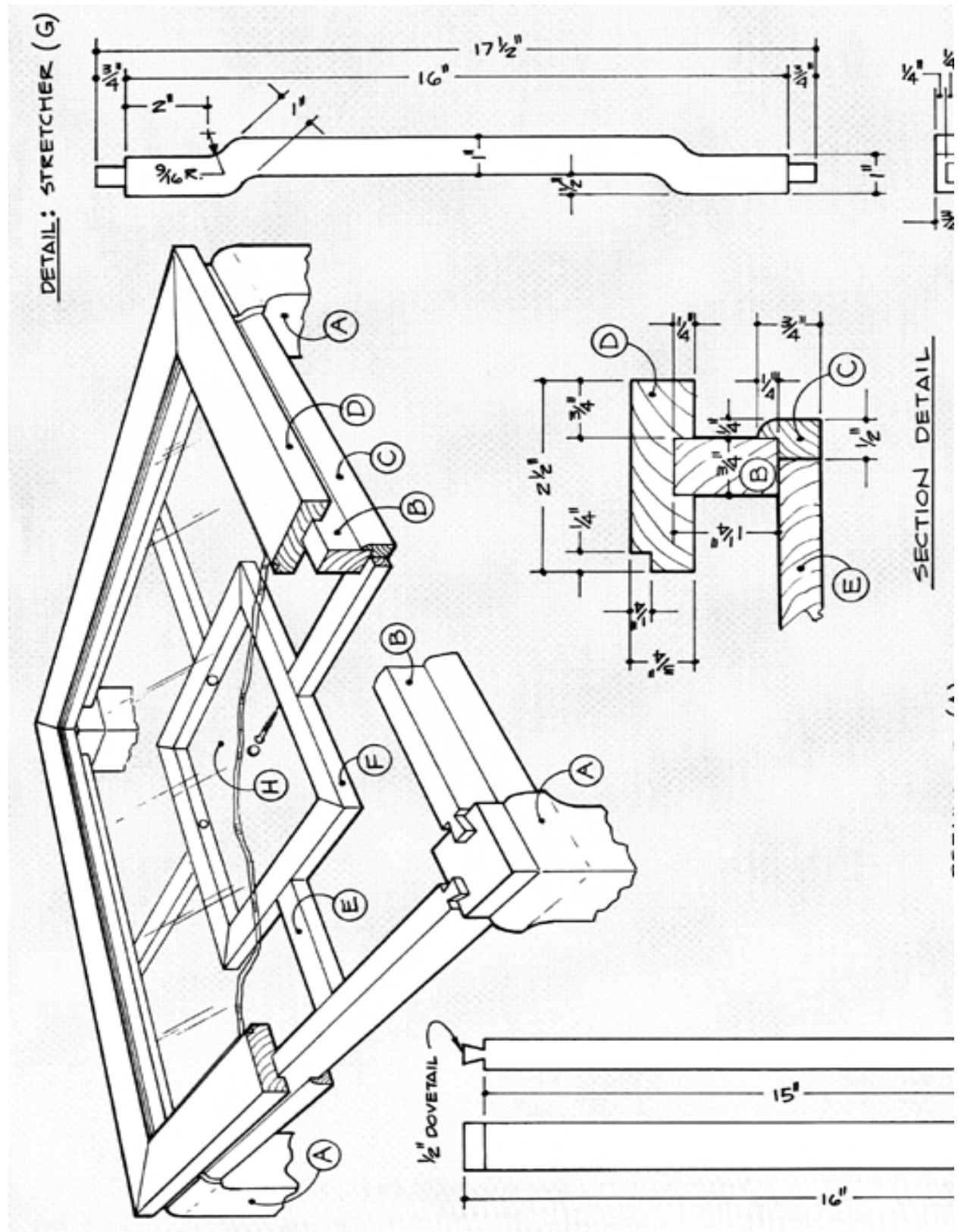

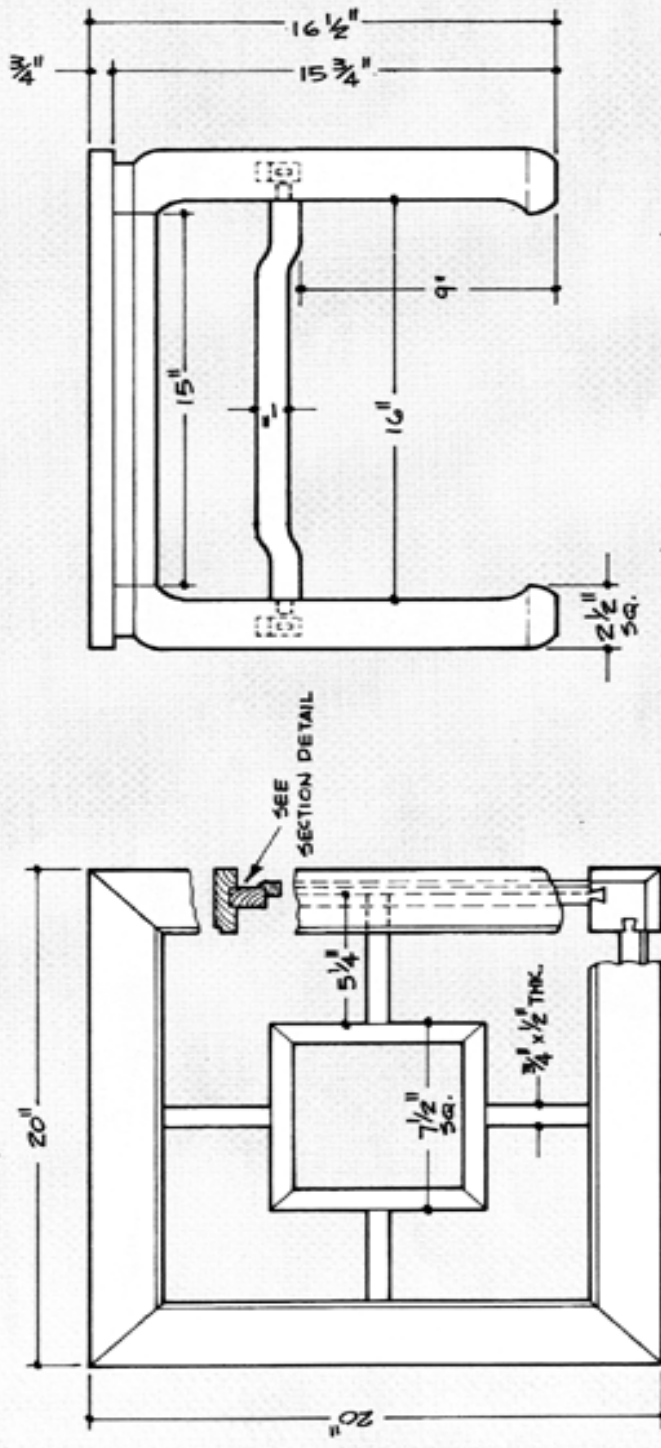
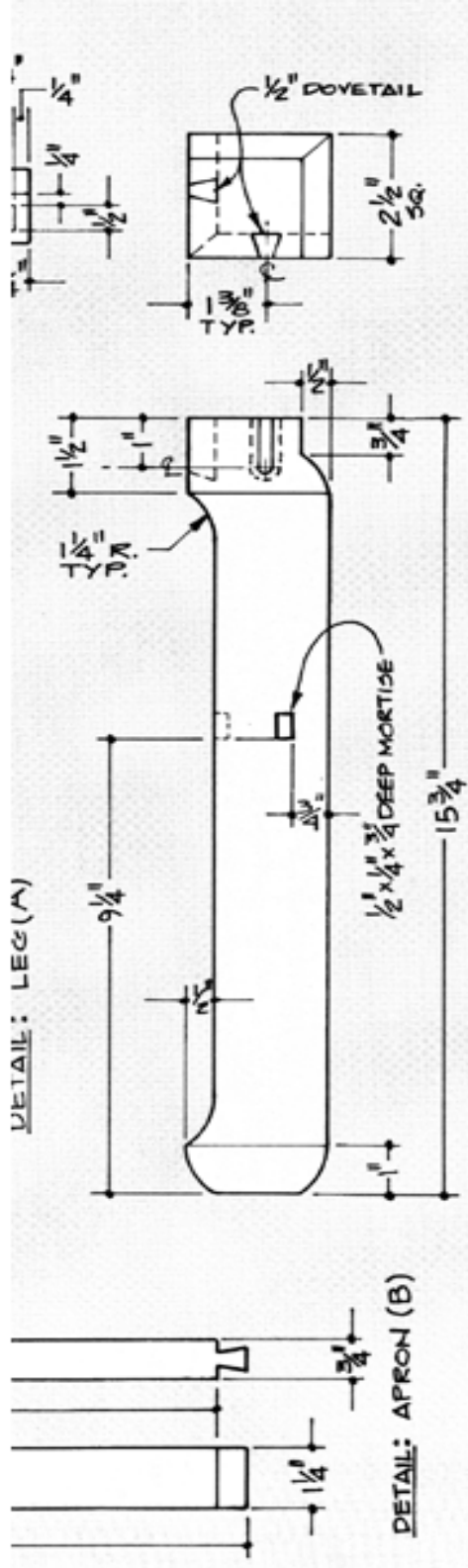

Art by The Drawing Board,
Prospect, CT

Chinese Tea Table Step-by-Step Instructions

1. Start with the four legs (Part A), made from the 3 x 3 stock.
2. Select 3" x 3" stock from which to make the leg pieces (A).
3. Cut the four leg pieces to length.
4. Use a disk sander to immediately joint the ends of the legs, as they will be more difficult to smooth later.
5. Use a router or drill press in conjunction with a dovetail bit to cut the dovetail grooves. **NOTE: It is important to do this before the band sawing, because afterwards the legs will not have easily available flat surfaces to rest the work upon.**
6. Cut 1/2" deep grooves centered 1-3/8" from the common corner on two adjoining sides of each leg, extending the cut from the end of the leg down exactly 1", measured at the center of the bit.
7. Mark one side of a leg that has a dovetail in it.
8. **NOTE** carefully the relation of the pattern to the dovetail groove: The long flat side at the top should be placed towards the adjoining side with the dovetail cut, leaving the short flat side that must be cut out on a blank side.
9. Use a circle gauge with a 2-1/2" diameter cutout to draw the curves.
10. Use the bandsaw and, leaving a small margin for sanding later, cut the drawn pattern.
11. Draw a reversed pattern on the remaining dovetailed face. **NOTE:** This second pattern will need to be drawn on a curved cut surface but, by using the curvature endpoints, this can be done surprisingly easily.
12. Use the bandsaw again to cut out the reversed pattern.
13. Sand the legs thoroughly, using a drum sander to sand the inside curves.
14. Lay out and mark the location of mortises for the stretcher (G).
15. Use a sharp 1/4" chisel to cut each mortise.
16. Repeat the process for all the legs.
17. Cut four 16" lengths of 1" x 2" stock to make the aprons (Part B).
18. Rip them to a 1-1/4" width.
19. Cut 1/2" into the ends, at a width that produces a tight joint with the table legs, to form the dovetails on the ends. **NOTE:** The aprons do not yet fit flush with the top of the legs, making the 1/2" extension of the dovetails critical. Whether or not they fit on the top frame depends upon the aprons being the correct length.

20. Fit the stretchers (G) individually by partially assembling (without glue) the table, placing the aprons with their dovetails into the grooves in the legs.
NOTE: The stretchers are fitted one at a time as they are mated to the cutout surfaces of the legs, for which the leg cutout and sanding process provides only imprecise depth control.
21. Make sure the raw cut edge of the rails is on top and will remain higher than the leg tops by 1/4" when correctly placed.
22. Number the legs and sides so that you can recreate this same parts relationship later.
23. Square the table carefully.
24. Measure the distance on each side from leg to leg at the mortise point to get the correct length for the stretchers.
25. Form the tenons.
26. Mark the stretchers according to the pattern.
27. Band saw the stretchers to shape.
28. Use a drum sander, being sure to turn with the grain and not into it, to final smooth the stretchers.
29. Final sand all finished pieces.
30. Test assemble the parts by first assembling the stretchers (G) into each of the legs (H).
31. Continue the test by adding the aprons (B), which will be 1/4" above the top of the legs.
32. Test-place a band clamp around the outsides of the legs at a height between the aprons and stretchers. NOTE: Once the clamp is tightened the assembly will take on a rigidity that will allow squaring the legs.
33. Finish testing when you feel all is satisfactory.
34. Glue each joint generously as it is being assembled.
35. Finish the assembly quickly, but with care.
36. Clamp the assembly.
37. Make sure everything is square.
38. Select a pieces of 1" x 3" stock from which to construct the top frame (D), which holds the glass as well as providing structural rigidity.
39. Cut four lengths, each just over 20".
40. Examine each pieces for the face with the best appearance.
41. Mark the opposite faces.
42. Use a dado blade to cut, in each marked face 3/4" from one edge (and therefore 1" from the other edge), a groove 3/4" wide and 1/4" deep.
43. Turn the pieces over and mark the top edge farthest from the groove (over the 1" surface left after grooving).

44. Use a jointer to cut this edge to form, on the inside edge of each piece, a 1/4" by 1/4" rabbet.
45. Set the rabbet edge on the inside and therefore shorter end.
46. Cut the miter ends of the prepared stock, making sure that the rabbet edge is on the inside and, therefore, the shorter edge.
47. Cut the other edges to 20".
48. Place all four pieces loosely on the table, like pieces of a picture frame, with the bottom groove mated to the aprons to make sure the top frame fits in place.
49. Make adjustments as necessary.
50. Glue the top frame members to the aprons, being sure to apply glue to the mitered ends of the top frame parts.
51. Make sure the miter joints fit well.
52. Use C-clamps to clamp the top frame members to the aprons.
53. Rip the remaining 1" x 2" stock carefully, using a feather board and a fence straddler pusher to maintain safety, to make the 1/2" x 3/4" stock needed for trim. **NOTE:** You will obtain two lengths of stock by cutting through the 3/4" thickness.
54. Use a jointer to finish the cut and make an accurate 1/2" width.
55. Measure and cut four pieces, each just over 15" long, from some of the stock just made to form the rail trim (Part C).
56. Cut a 1/4" x 1/4" rabbet the length of one edge of each piece.
57. Use a sanding block to round the other edge across the narrow face of the pieces.
58. Final sand the four trim rails.
59. Check the rails for length against each of the aprons.
60. Build the rabbet to receive the exposed bottom edge of the aprons (see Section Detail).
61. Adjust the length of the trim rail if necessary.
62. Put some glue in the rabbets and glue them in place.
63. Clamp with wooden cabinetmaker's clamps.
64. Cut the remaining stock carefully to four lengths, each exactly 5-1/4", to make the web-work pattern.
65. Miter cut four more lengths so that the long side is exactly 7-1/2", leaving the short side exactly 6".
66. Use a disk sander to cut all eight pieces a little long.
67. Joint the cuts to make the correct length.
68. Glue and assemble the entire web-work.

69. Clamping with miter clamps.
70. Allow the glue to dry completely, as web-work is not inherently strong and insufficient curing will only make the assembly more fragile.
71. Lay the table assembly down on a cloth-covered level surface.
72. Mark the exact center of each length on the exposed bottom surface of the aprons.
73. Place parallel lines across the grain of the aprons 3/8" to either side of the center mark to demarcate the placement of the webwork ends.
74. See the Section Detail for the relationship between the apron, the trim rail, the top frame, and the webwork.
75. **NOTE** that parts E are joined to parts F with small countersunk and plugged wood screws.
76. Place a layer of glue within the marked area of the aprons.
77. Lay the webwork, best face down towards the top frame, on the glued areas.
78. Adjust position (if necessary) until all four ends of the webwork fall within their marked areas.
79. Scrape excess glue.
80. Clamp each end with a large cabinetmaker's clamp placed "under" the top and "over" the webwork end.
81. Use a sanding block to preserve the flatness of the surfaces.
82. Sand, if necessary, the appropriate edge near each joint to make the miter joint exactly on the corner.
83. Round the outside edges of the top frame slightly (1/16" radius) to remove sharp corners.
84. Do the same to the vertical edges of the legs and the bottom edge of the rail trim.
85. Use finish grade sandpaper to touch up the areas around all the joints and remove any glue traces on the surface.
86. Finish sand the trim rail and top frame, making sure that the top frame joints are perfectly smooth.
87. Apply three coats of clear penetrating oil finish, allowing coat each to soak in for about five minutes before wiping off the excess.

These plans were originally published in Volume 7, Issue 4 of *The Woodworker's Journal* (July/Aug. 1983, pages 38-40).