

Wheel in the flowers

Build this cart to display your potted colour

Spring is here, birds are singing and flowers are blooming. Here's a great project for making the most of what spring has to offer – a cute flower cart to fill with potted colour, and change and replenish whenever you wish. So, need some colour? Just wheel it in. *By Dieter Mylius*

Here's how

Step 1 To prepare the axle beams (A) make a template by transferring the pattern from the diagram (Item A) to a 440 x 90mm offcut of plywood. Cut out the template, then transfer pattern to the stock for the axle beams. Note: only the front axle has a housing cut into it to accept the tongue (B). Cut out axle beams, smooth edges, then, at the end of each axle, centre an 8mm hole. The holes will be used to hold the wheels.

Step 2 Cut base components (C1, C2) slightly longer than required. Drill through the sides of the narrow base pieces (C1) and counterbore so they can be screwed to the edges of the wide base component (C2). Rip the wide base to a width of 280mm, apply construction adhesive and screw on the side pieces. Plug the counterbored holes by gluing in 10mm plugs (cut with a plug cutter) or dowelling. Screwing the base components together allows you to continue working without waiting for the adhesive to set. Check the total width is 360mm. Set a sliding bevel to 75° and draw an angled line on a piece of scrap timber for future reference; this angle is used for all sloping surfaces. At one end of the base assembly, draw a 75° line down the edge, then square across base assembly. Mark the 750mm length of

the base on the upper surface, square across and mark the opposite bevel down the edge. Saw both ends at the angle.

Step 3 On the stock for the sides (D), draw the 75° angle and cut. Measure 750mm along the short edge, mark in a 75° angle running in the opposite direction and cut.

Step 4 Use the angled ends of the sides to mark height of the ends (E). Cut and plane top and bottom edges to 75° so they match the shape of the sides. Find the centre in height of all side and end pieces and rout a shallow V-shaped groove parallel with the top edge to give the impression of separate boards.

Step 5 To form the body, screw the base to the sides, then add the ends, screwing in from base and sides. Along top measure 300mm from each end and nail on the vertical side battens (F). To install the end and corner battens (G, H), mark the required length and angle from the body, then cut. The battens will cover the screw heads at the corners.

Step 6 On the underside of the body, measure 155mm in from both ends, square a line across, then centre and screw the axle beams to these lines. Prepare the tongue (B), by bevelling the front corners and

drilling a 15mm-diameter hole centred 30mm from the front. Insert in the housing in the axle and screw to the underside of the body.

Step 7 Transfer the pattern for the wheels from the diagram (Item I) to an offcut of 3mm plywood, then make a template. Cut out with a jigsaw after drilling a 10mm starting hole in each corner of the spaces between wheel spokes. Transfer the pattern to four blank squares, bore a 10mm hole in corners as for template, then cut out with the jigsaw. Smooth the curves so they are even and the wheels symmetrical. Use a round-over bit in a router on both sides to refine the shape of the wheels.

Step 8 Before fixing wheels, fill all holes and blemishes in wheels and body assembly. Sand smooth all over. Paint the cart with acrylic paint; we chose white, pale grey and pale blue. When dry, drive a 10mm furniture stud into holes in axle ends, add wheels and secure with washers and nylon locking nuts. Drill drainage holes in base.

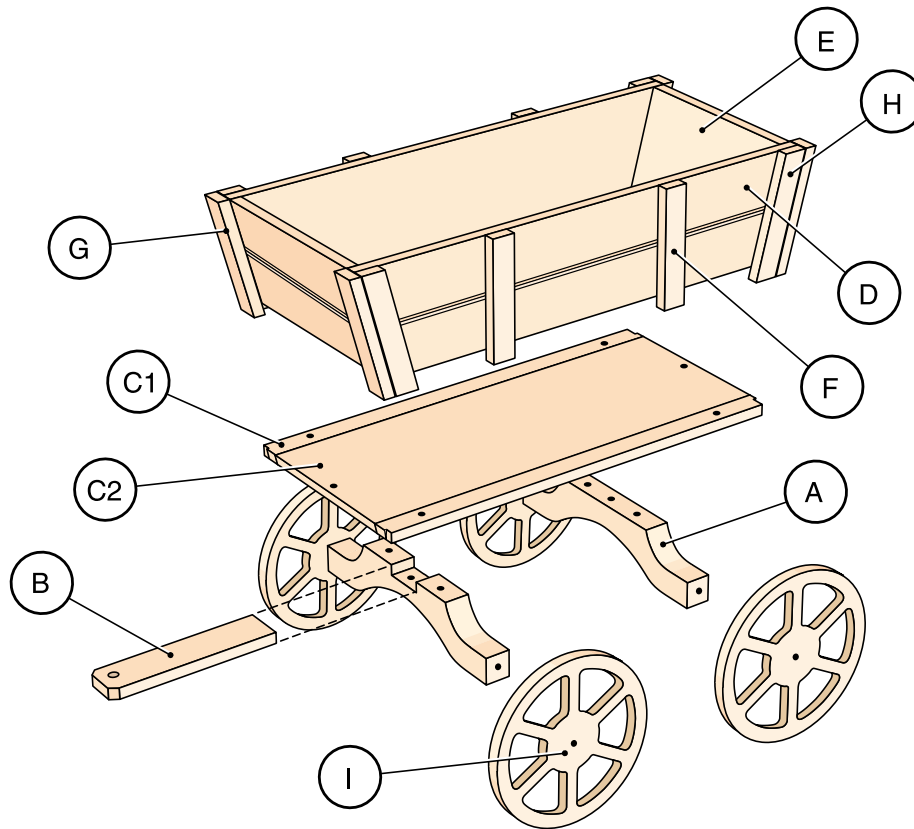

Item I

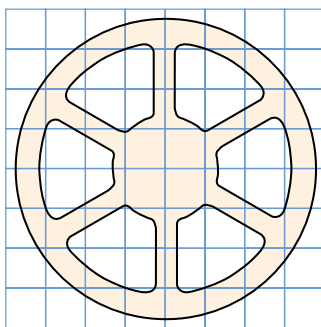

40 x 40mm grids

Item A

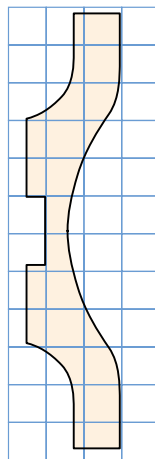

What you will need

Item	Part	Size	Material
A	Axle beams (2)	90 x 45 x 440mm	Treated pine
B	Tongue	70 x 19 x 300mm	Treated pine
C1	Base (2)	40 x 19 x 750mm	Treated pine
C2	Base	290 x 19 x 750mm	Treated pine
D	Sides (2)	190 x 19 x 852mm	Treated pine
E	Ends (2)	210 x 19 x 360mm	Treated pine
F	Side battens (4)	40 x 19 x 209mm	Treated pine
G	End battens (4)	40 x 19 x 220mm	Treated pine
H	Corner battens (4)	40 x 19 x 230mm	Treated pine
I	Wheels (4)	290 x 19 x 290mm	Treated pine

You'll also need plywood offcuts for templates of wheel and axle; four furniture studs, washers and nylon locking nuts; assorted screws; paint. All of the joints are glued with construction adhesive and screwed unless otherwise indicated. Check the fit of all components against the actual unit as it is being built.