



Hammock Frame

Plan No. 868

Copyright U-Build, Inc., 1997.
All rights reserved. Printed in the U.S.A.

A good book, a tall glass of iced tea and the gentle swaying motion of a shady hammock on the patio, next to the pool or in the yard-sounds like paradise, doesn't it? With a few basic tools and some inexpensive materials, any do-it-yourselfer with a free weekend can create a place to relax and catch a few winks.

This easy-to-build hammock frame project calls primarily for straight cuts and requires only basic construction techniques.

Made entirely of straight-grain Douglas fir, the frame is not only sturdy, comfortable and safe, but it's attractive enough to blend nicely with any landscaping.

Designed to fit a standard-size hammock sling, the completed project measures 16 feet long by 4 feet wide.

Bill of Material

Quantity	Size	Material	Item
5	2" x 6" x 12'	Straight Grain Douglas Fir	A, B, C, D
1	2" x 8" x 8'	Straight Grain Douglas Fir	E
2	2" x 4" x 8'	Straight Grain Douglas Fir	F
2	1/2" x 8"	Eye Bolts	
14	1/2" x 4 1/2"	Carriage Bolts	
8	1/2" x 3"	Carriage Bolts	
20	1/4" x 3 1/2"	Lag Bolts	
26	1/2"	Flat Washers	
20	1/4"	Flat Washers	
26	1/2"	Nuts	
1 gallon		Waterproof Finish	

NOTES

1. Read all instructions and check materials before beginning work.
2. Read manufacturer's instructions before operating equipment.
3. Cut all wood to exact size. Follow the cutting schedule.
4. *Always* wear safety glasses.
5. Use only *straight grain lumber* for your hammock frame project. Do not use any boards that have checks, splits, knots or defects.
6. When drilling the 1/2" holes in board B to hold the eye hook, great care should be taken to ensure that the hole is parallel to the face.

Cutting Schedule

Part	Qty	T	W	L	Material
A	2	1 1/2"	5 1/2"	144"	Straight Grain Douglas Fir
B	2	1 1/2"	5 1/2"	59 1/2"	Straight Grain Douglas Fir
C	2	1 1/2"	5 1/2"	83"	Straight Grain Douglas Fir
D	4	1 1/2"	5 1/2"	23 1/2"	Straight Grain Douglas Fir
E	2	1 1/2"	7 1/4"	48"	Straight Grain Douglas Fir
F	4	1 1/2"	3 1/2"	41 1/16"	Straight Grain Douglas Fir

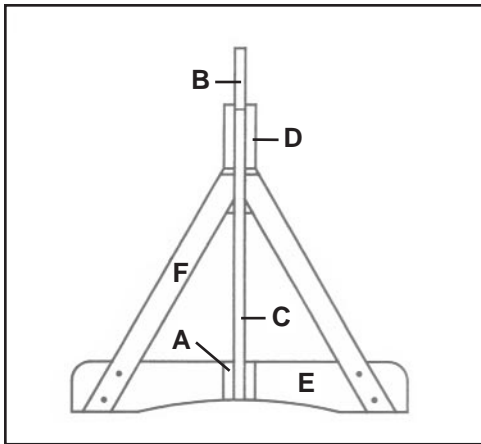
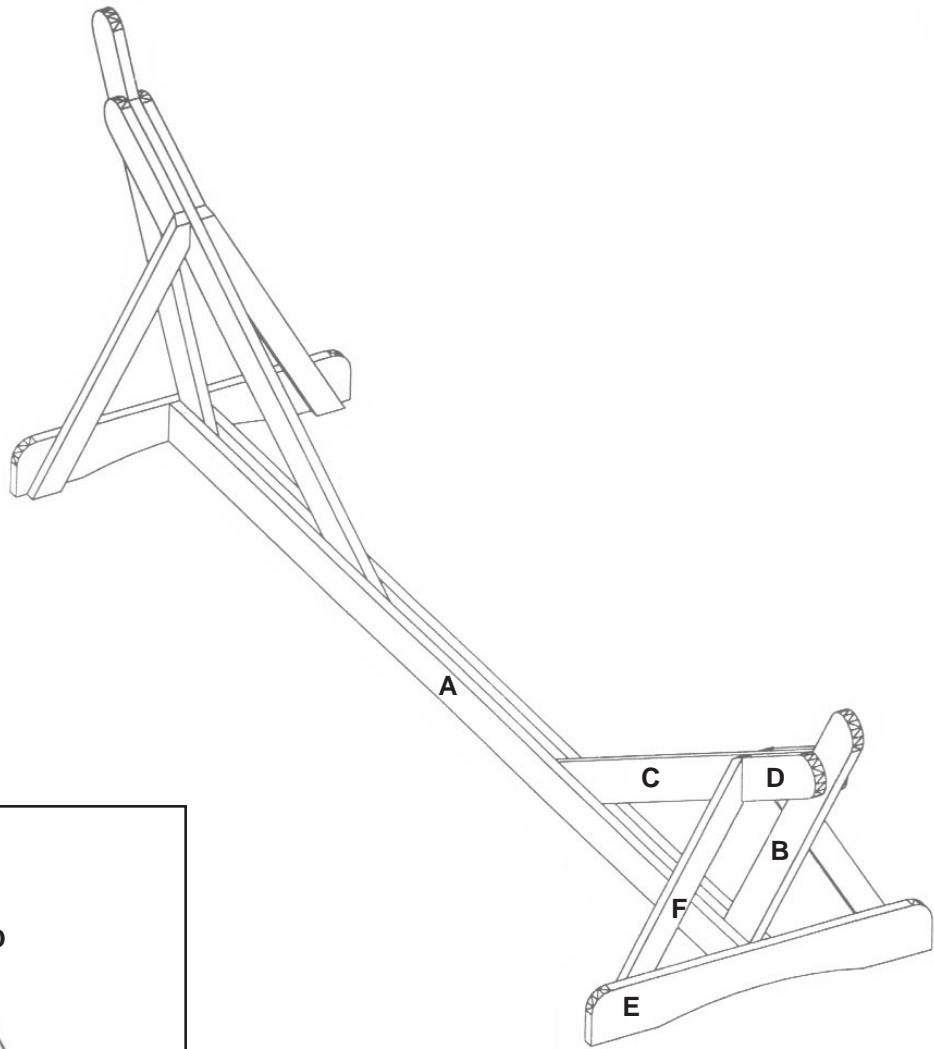

Section A-A

**CONSTRUCTION
DIAGRAMS**

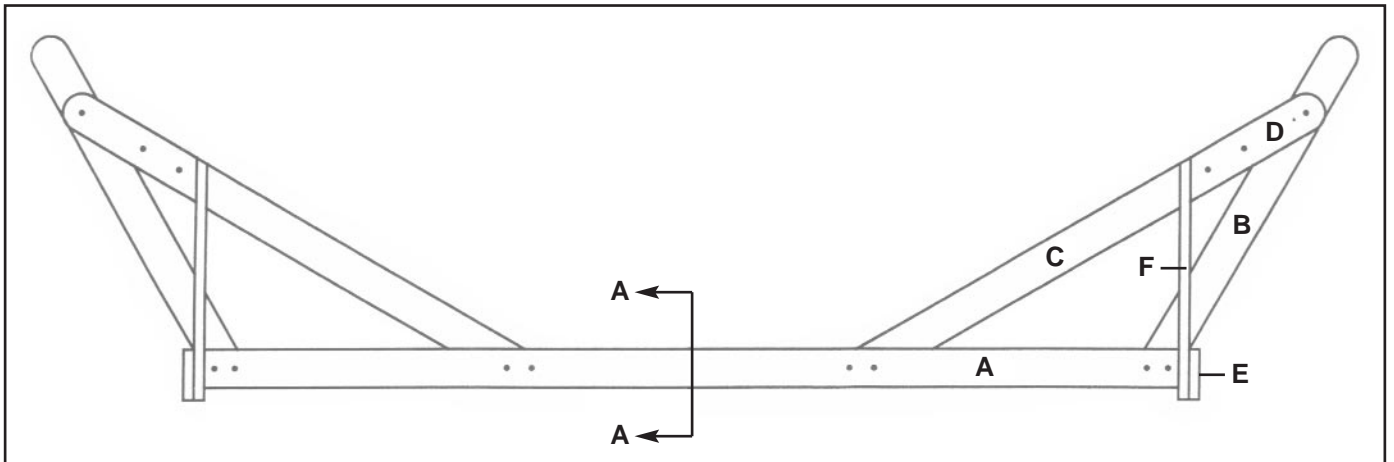

Assembly Instructions

Page One

Read all instructions before beginning any work. Cut all material to sizes shown in cutting schedule.

1. Cut all boards to the proper size. Refer to the cutting schedule and Figures 1 through 7.
2. Use a jigsaw to cut angles and radii on all boards. Check the isometric for the location of all the joints and route all exposed edges with a $3/8$ " radius bit.
3. Drill a $1\ 1/8$ " hole $1/4$ " deep on the top edge of board B. Drill a $1/2$ " hole through the rest of board B. See Figures 1 and 2. Note: The $1/2$ " hole must be parallel to the face of the board to ensure proper strength.

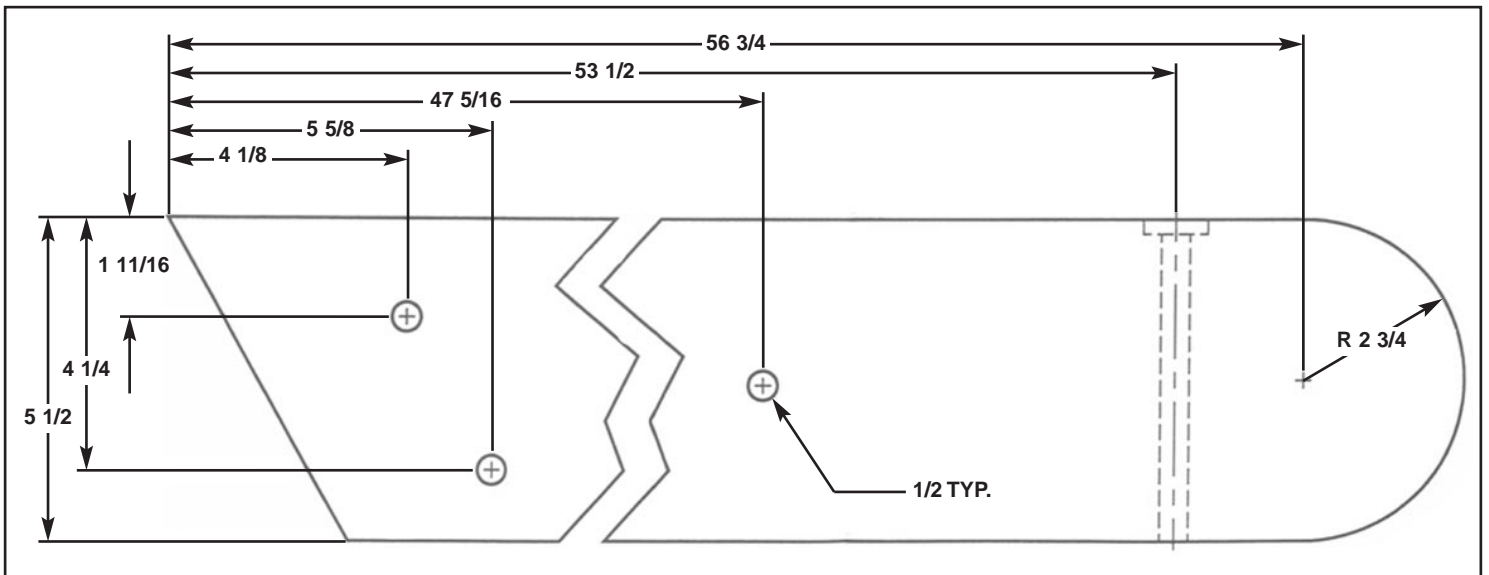

Figure 1
BOARD B

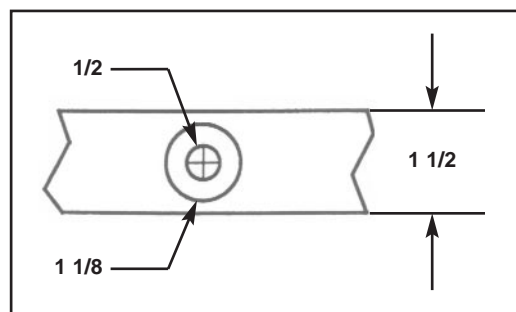

Figure 2
BOARD B

Assembly Instructions

Page Two

Read all instructions before beginning any work. Cut all material to sizes shown in cutting schedule.

4. Locate and drill 1/2" holes in boards as shown in Figures. Countersink eight 1 1/8" by 1/2" deep holes on one side of one of the A boards. Countersink two of the D boards and all of the F boards for washers and nuts. Refer to Figures 3, 4 and 5.

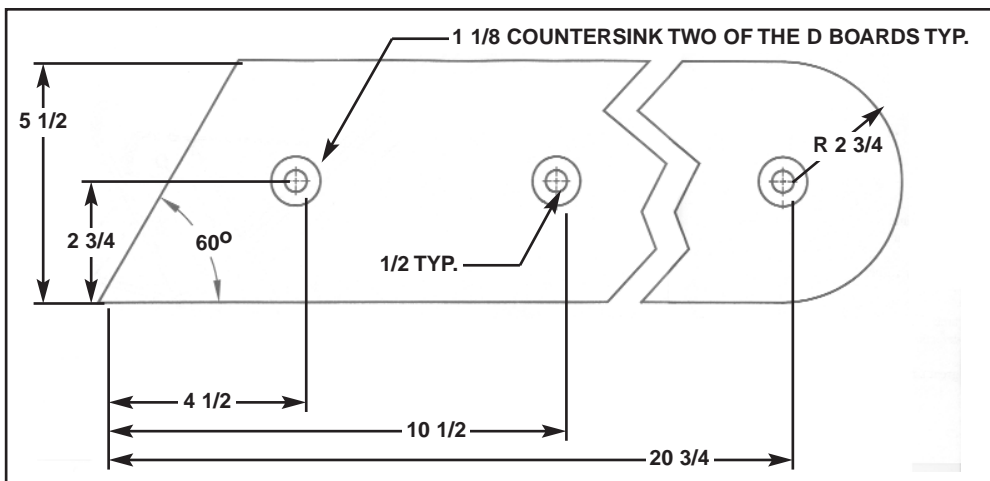
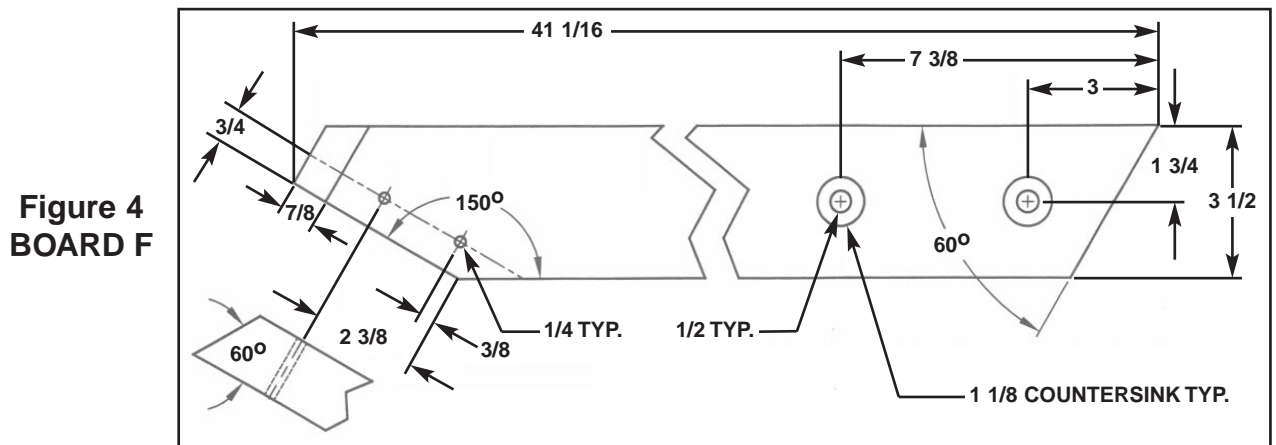
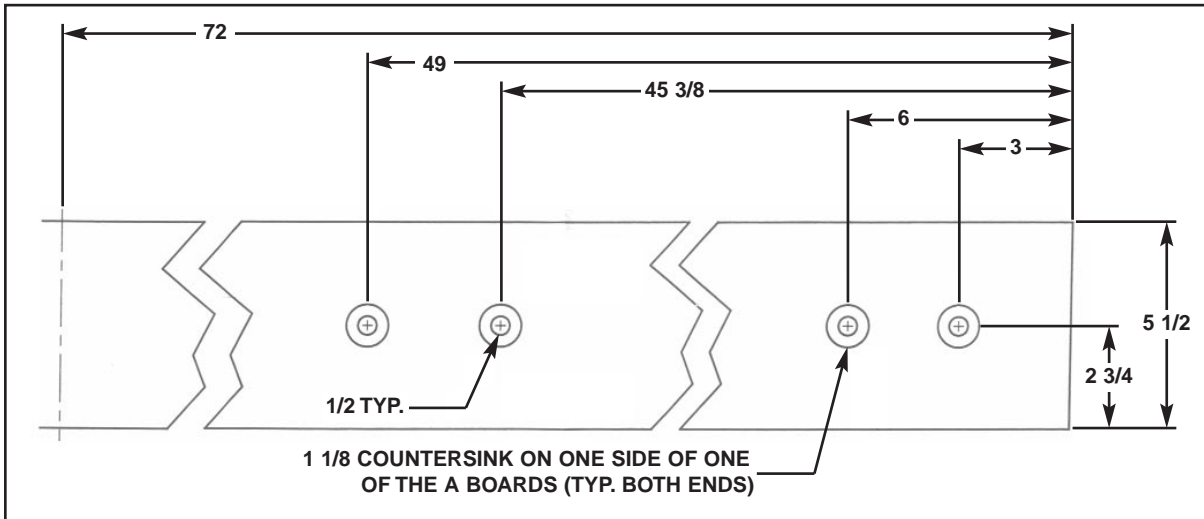

Assembly Instructions

Page Three

Read all instructions before beginning any work. Cut all material to sizes shown in cutting schedule.

- Use a scrap piece of plywood cut at a 60 degree angle to align board B to board A. Use four 1/2" by 4 1/2" carriage bolts to attach boards A to B and C. Refer to Figures and isometric.
- Use 2 1/2" drywall screws to temporarily hold board D to B and C.
- Bolt board D to B and C. Use 4 1/2" carriage bolts.
- Insert the 1/2" by 8" eye bolts and washers into board B. Use a washer and two 1/2" nuts as jam nuts to secure eye bolt.
- Tighten bolts on board A.
- Drill six 1/4" holes in board E. Attach E to A using six 1/4" by 3 1/2" lag bolts and washers. Refer to Figure 6.

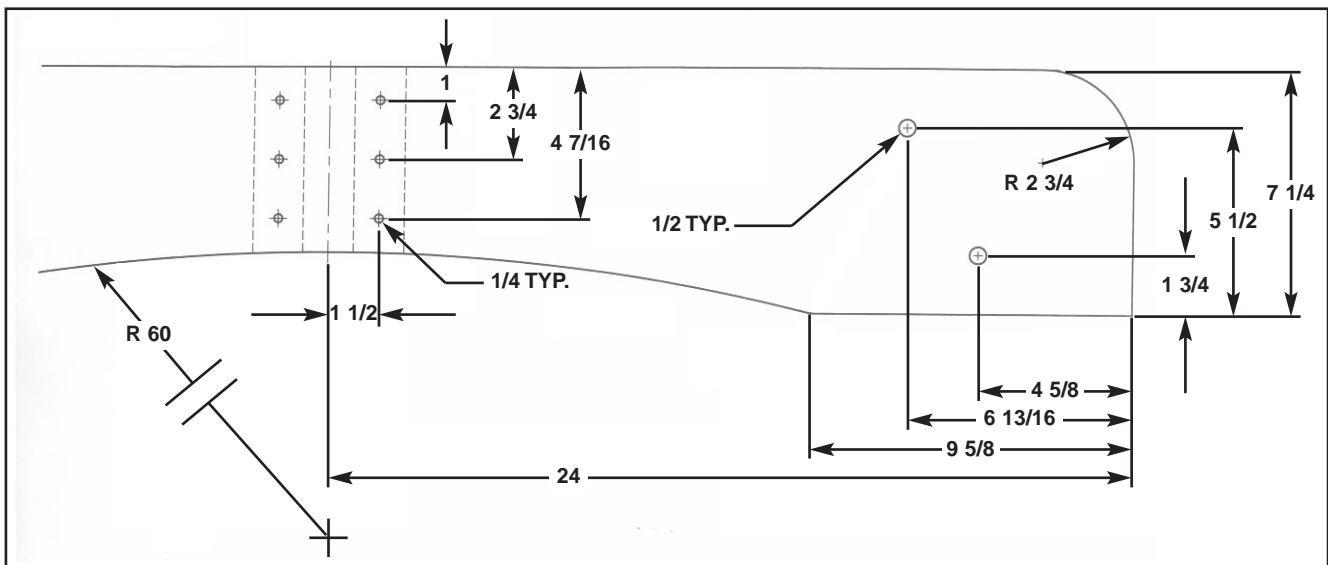

Figure 6
BOARD E

- Insert two 3" carriage bolts through board E into F. Use one washer and nut for each bolt. Drill two 1/4" holes in the top of board F. Use two 1/4" by 3 1/2" lag bolts and washers to attach board F to D. Refer to Figure 4.

Assembly Instructions

Page Four

Read all instructions before beginning any work. Cut all material to sizes shown in cutting schedule.

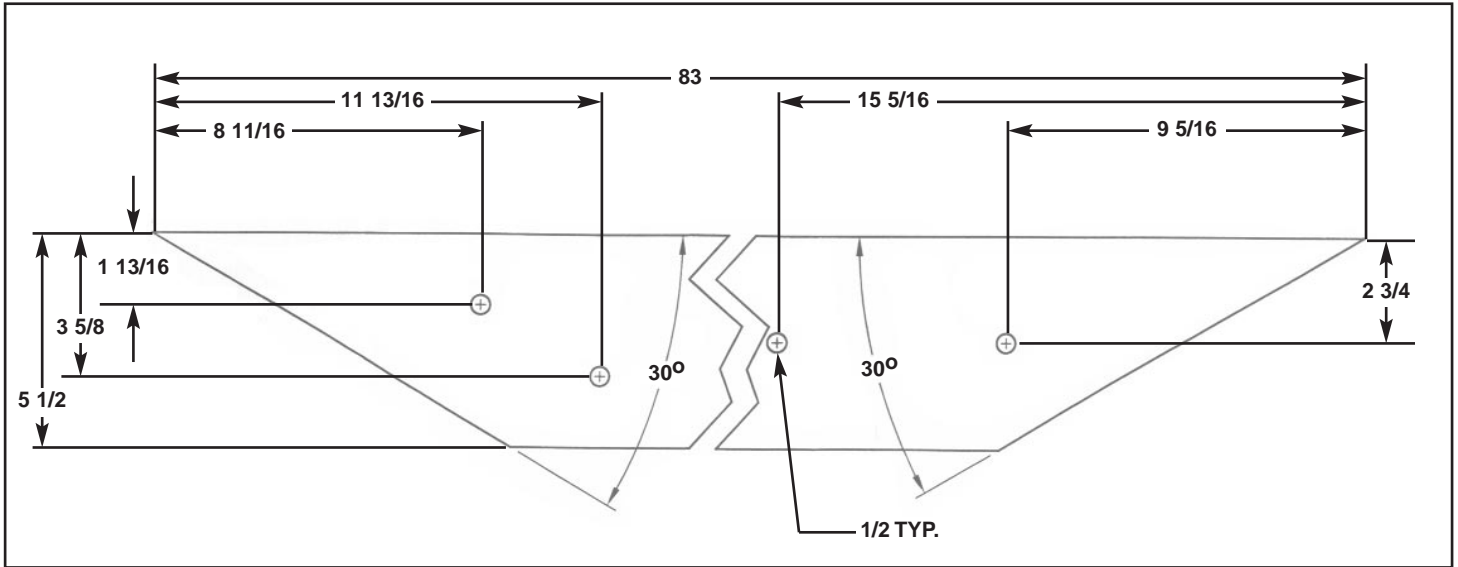

Figure 7
BOARD C