

## THANK YOU!

---

You have successfully downloaded a sample woodworking plan from PlansNOW. This sample represents the same level of quality you'll find in more than **200** woodworking projects and technique articles at PlansNOW! See details below.



### Tips for Trouble-Free Printing

► **Get the latest version of FREE Adobe® Acrobat® Reader®.** For best results printing our plans, use Adobe Acrobat Reader 5.0 or newer. This is a FREE download.

[Click here](#) or go to [www.adobe.com/products/acrobat/readstep2.html](http://www.adobe.com/products/acrobat/readstep2.html)

► **Clear memory.** Most printing problems can be avoided by freeing up memory on your computer and printer before printing from Acrobat Reader. Close all other programs that may be running and turn off your printer for at least 15 seconds to flush printer memory.

► **Print in batches.** Our larger project plans will print more successfully if you print a few pages at a time. For example, with a 12 page downloadable plan, select pages 1-6 in the print command window and print these pages only. Then select 7-12 and print.

► **Get advanced printer help.** Visit the Adobe Reader Support web site for detailed instructions in troubleshooting common printer problems.

[Click here](#) or go to [www.adobe.com/support/techdocs/150d6.htm](http://www.adobe.com/support/techdocs/150d6.htm)

### A Plan for Every Project!

Let your imagination go at PlansNOW as you browse **more than 200** woodworking project plans and technique articles—each ready for immediate download to your computer!



Tables-Cabinets

► [Click Here](#)



Home Office

► [Click Here](#)



Shop Storage

► [Click Here](#)



Garden-Patio

► [Click Here](#)



Techniques

► [Click Here](#)

**Plans NOW MEMBER**

**Save 20% on every purchase!**

Join our PlansNOW Members list and save 20 percent on every item in the store. You'll also get a FREE downloadable technique article just for signing up!

[Click here](#) or go to [www.plansnow.com/join.html](http://www.plansnow.com/join.html)

### Need Hardware? Woodsmith Project Supplies 1-800-444-7527

For plans that require unique or hard-to-find hardware and accessories, we may have a kit available for purchase. Please contact Woodsmith Project Supplies for more information.

**Contact Us.** Have a question about PlansNOW? We want to hear from you!

E-mail: ► [planman@augusthome.com](mailto:planman@augusthome.com) Phone: ► 1-800-333-5441 (Mon-Fri 8-5 Central time)

## MANTEL CLOCK

*Classic design. Easy to build. And it's sized small enough to fit just about anywhere.*



There's no doubt about it — what grabs your attention right away is the wood. It's curly maple. This figured wood is so dramatic that you might be inclined to think “the wood makes the clock.” But while I appreciate the beauty of the curly maple, there are a couple other reasons why I like this clock as much as I do.

**DESIGN.** First of all, there's the design. This mantel clock has a traditional look to it. Its clean lines and simple molding would look great no matter what wood you used.

**CONSTRUCTION.** The other reason I like this clock isn't easy to see. In fact, you might miss it altogether, if you weren't looking for it. In spite of its elegance, there's nothing very difficult about building this clock. Everything is held together with simple joinery, and it houses a quartz movement, which is readily available and easy to install.

### CLOCK BODY

The body of this clock is quite simple. It starts out as an H-shaped frame that's sandwiched between a layer of molding and a top and bottom.

**SIDES.** I began work on the body by cutting the two **sides (A)** to size from 1/2"-thick stock, see drawing below.

With the sides cut, next I cut a 3/8"-wide groove 1/4" deep in each side. Then I glued two 1/2" x 3/8" **stops (B)** in each groove, see drawing and detail 'a' below. The lower stop is for a drawer. The upper stop will position both the clock face and a face frame.

Note that there's a 1/2"-wide gap between the upper and lower stops, see detail 'b'. This is for a divider that's added later, refer to drawing on page 2. (One easy way to create this gap is to use a 1/2"-thick scrap piece as a temporary spacer between the stops.)

To complete the sides, the last step is to glue a **drawer guide (C)** behind each lower stop, see detail 'b' on page 1.

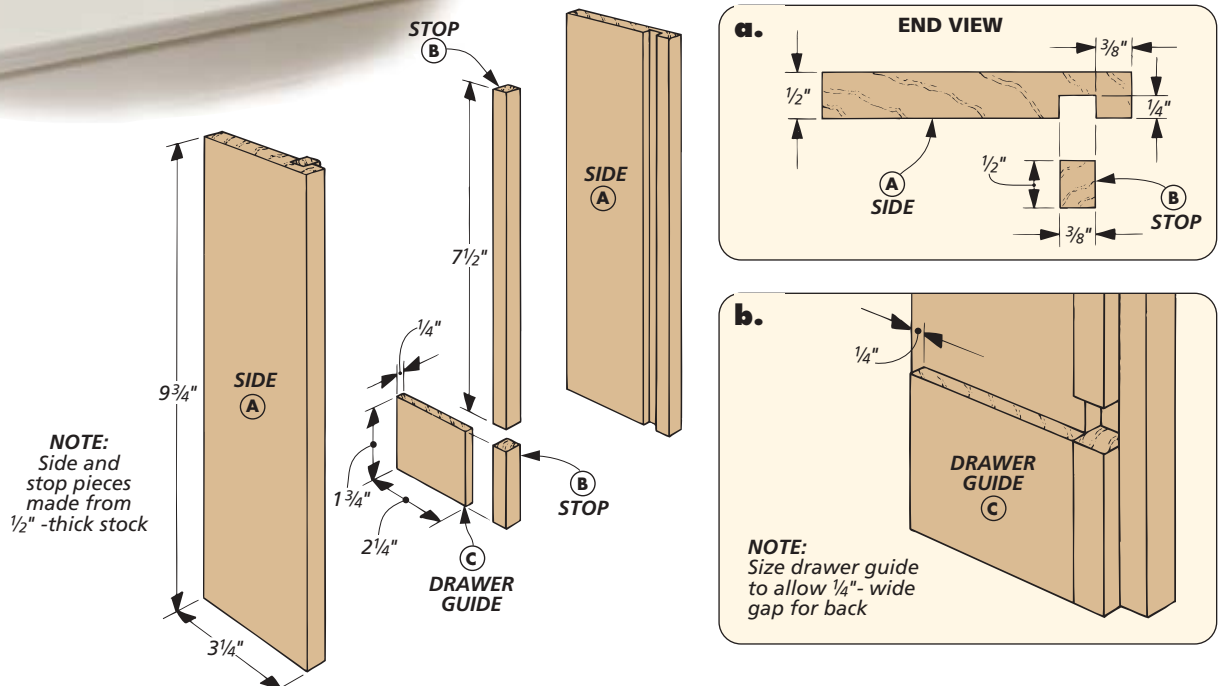

These guides fit flush with the outside face of the lower stop and should stop  $\frac{1}{4}$ " short of the back edges of the sides to allow for a plywood back.

**DIVIDERS.** Next, to create the H-shaped frame, I connected the two sides with a divider (D), see drawing at right. This piece is sized so it's flush with the sides in front and the drawer guides in back, see detail 'a' at right.

The trick to gluing the divider and sides is to keep the assembly square. So I used a spacer that matched the length of the divider, see Fig. 1.

**TOP & BOTTOM.** With these pieces assembled, I added a layer of molding to each end, see drawing above. And then added the top and bottom pieces.

First, I cut two cove molding (E) pieces to size from  $\frac{3}{4}$ "-thick stock, see drawing. These pieces are cut to create a  $\frac{1}{8}$ " lip at the sides and front. (Mine were  $3\frac{7}{8}$ " x  $9\frac{3}{4}$ ".)

To shape the molding, I routed the ends and front with a  $\frac{1}{2}$ " cove bit, see Fig. 2. Then I screwed them to the sides flush with the back, see Fig. 3.

Now with the cove molding in place, I added  $\frac{1}{2}$ "-thick top and

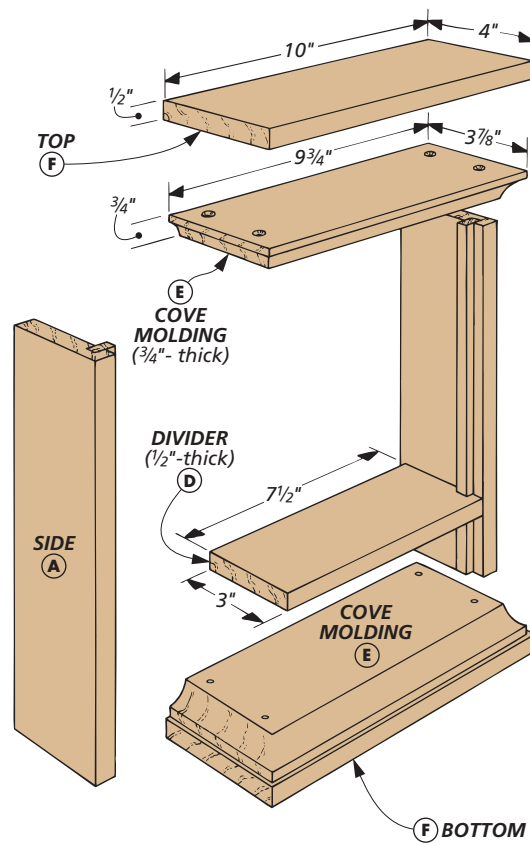

bottom (F) pieces, see drawing. These overhang the cove molding  $\frac{1}{8}$ " on the front and sides, see Fig. 4a. But there is no profile routed on their edges. And since I didn't want screws

showing, they're simply glued in place.

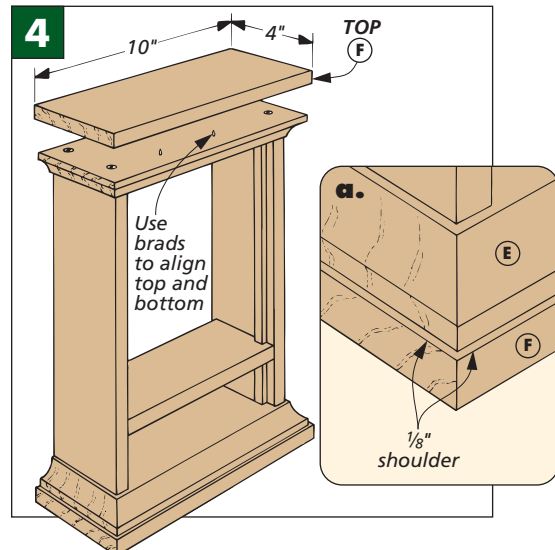
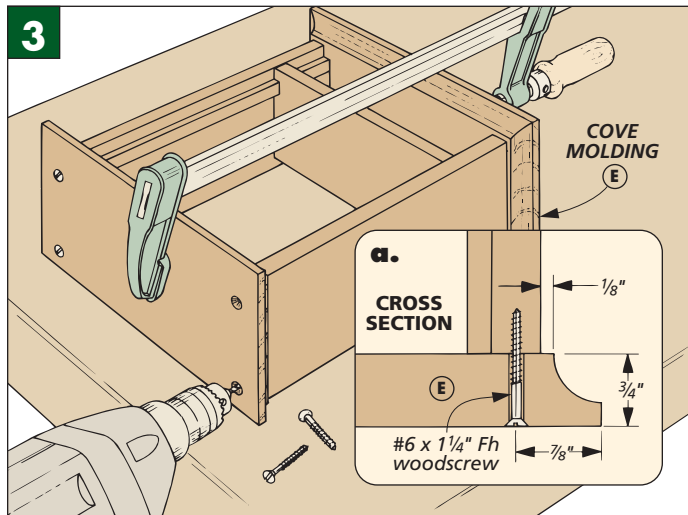
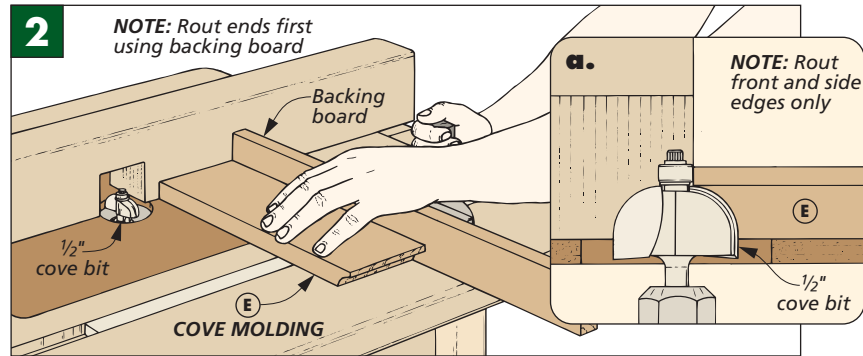
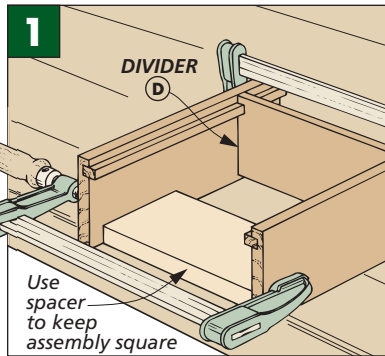

## Frame

Now that the basic body of the clock is complete, I turned my attention to the frame that holds the glass, see drawing at right. This is a simple mitered frame that fits the opening above the divider and stands a little proud of the sides ( $\frac{1}{8}$ ").

**FRAME PIECES.** To begin, I ripped the frame pieces (G) to width ( $\frac{7}{8}$ " from  $\frac{1}{2}$ "-thick stock, see drawing at right. But before mitering these pieces to final length, there's a little shaping that needs to be done on the router.

First, I routed a  $\frac{1}{8}$ " roundover along both outside edges of each frame piece, see detail 'a' at right.

Next, to hold the  $\frac{1}{8}$ "-thick glass and the  $\frac{1}{4}$ "-thick glass stops, I routed a rabbet along the inside edge of each piece, see detail 'b' at right. Note: Because this rabbet is  $\frac{3}{8}$ "-deep, I'd recommend routing it in two passes.

When the rabbet is routed, the frame pieces can be mitered to size, see drawing. Here, you want a snug fit, so after mitering one end of each, I cut each piece to length so it fit the opening exactly.

**ASSEMBLY.** Now the frame can be glued together. But don't glue it into the body at this point. It will be easier to make and fit the glass stops before the frame is in place.

**GLASS STOPS.** The glass stops (H) are simply  $\frac{1}{4}$ "-thick quarter round strips, see drawing above. But making

**NOTE:** Glass and stops are added after staining is complete

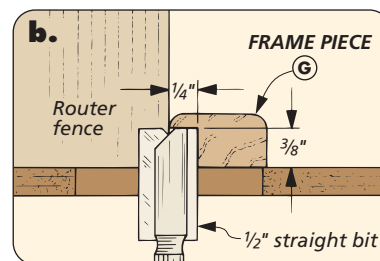
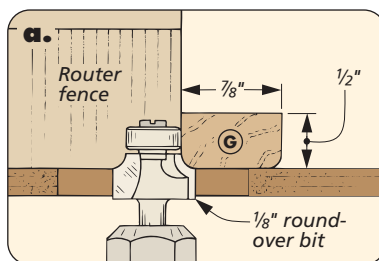
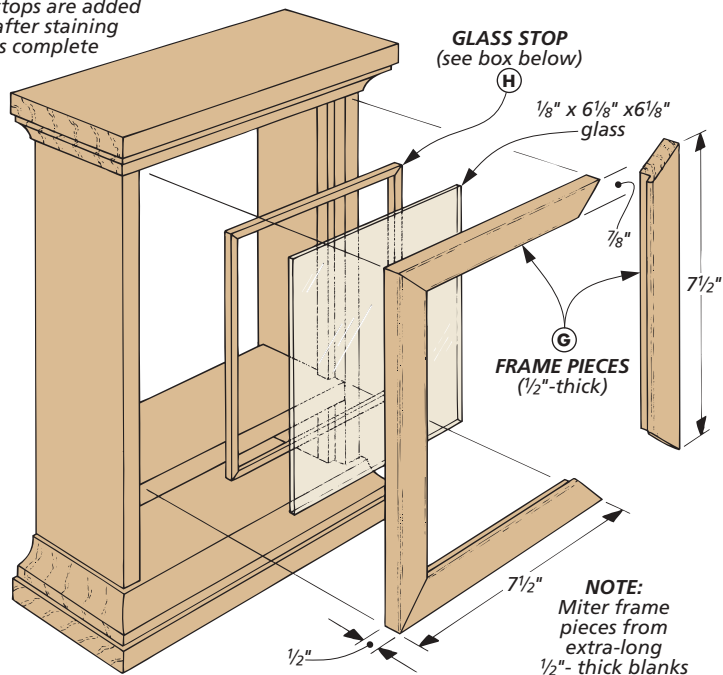

these strips can be dangerous. Because they're so small, they can get hung up in the insert plate on the table saw, and there's potential for kickback. So I started with oversize blanks and used a zero clearance

insert in the table saw, see box below.

With the stops routed, they can be mitered to fit the rabbet in the frame. But I didn't glue the frame or tack in the stops quite yet. Instead, I waited until after the clock had been stained.

## QUARTER ROUND MOLDING

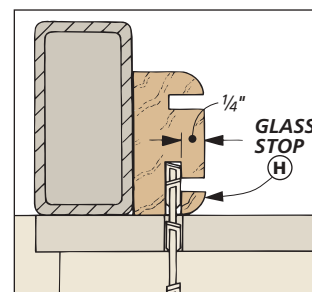
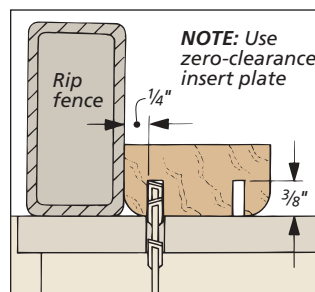
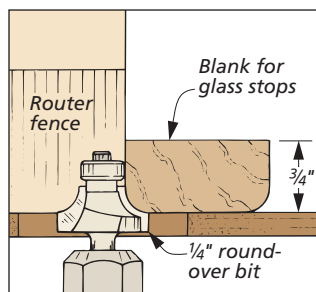

To hold a piece of glass in a frame, I often use small strips of quarter round, see photo above. But routing and ripping thin strips can be dangerous, so I use oversize blanks.

First, I cut a  $\frac{3}{4}$ "-thick blank roughly 2" wide. Then to create the  $\frac{1}{4}$ " round profile, I rout two edges with a  $\frac{1}{4}$ " round-over bit, see left drawing above. Now, cutting the quarter round strips from

the blank is a simple, two-step procedure. First,  $\frac{3}{8}$ "-deep kerfs are cut  $\frac{1}{4}$ " from the rounded edges, see center drawing. (To be safe, be sure to use a zero-clearance insert plate in your table saw.)

Next, the blank can be stood on edge, and the molding strips can be cut away, see right drawing. Just make sure they fall to the waste side of the blade.



## Movement Support

At this point, the body of the clock is almost complete. All that's left is to mount the movement and add a back.

**MOVEMENT SUPPORT.** To mount the movement, I took a slightly unusual approach. The clock face and quartz movement are attached to a movement support that simply slides in the opening in the back, see drawing.

This way, if you ever need to get at the hands in front, all you have to do is slide the movement support out through the back of the clock body.

**FRONT.** To make the movement support, I cut a **support front (I)** from  $\frac{1}{4}$ "-thick plywood, see Fig. 5. The size of this piece depends on the opening inside the clock. I cut my front to fit the opening exactly ( $7\frac{1}{2}$ " x  $7\frac{1}{2}$ "), and then trimmed it slightly so it would slide in without too much trouble.

The only thing that needs to be done to this front piece is to drill a  $\frac{5}{16}$ "-dia. hole in the center. This is for mounting the quartz movement, refer to detail 'a' above right.

**SIDES.** Next, I cut two **support sides (J)**, see Fig. 5. These match the height of the front. But more importantly, their widths put them flush with the back of the divider when the support is slid inside the clock. (Mine were 2" wide. But this may vary depending on the thickness of your clock face.)

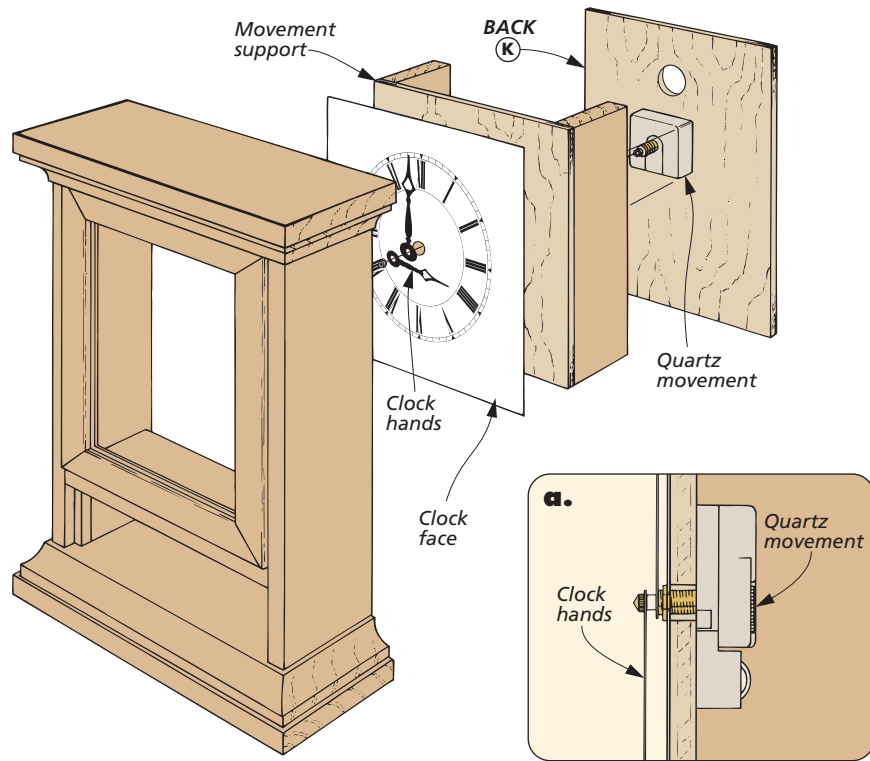

When the sides are glued to the front, the movement support is complete. But I waited to add the quartz movement until after the clock had been finished. At that point, adding the movement is just a matter of feeding its post through the front and the clock face and securing them with a nut, see detail 'a' above. Then the hands can be attached to the post.

**BACK.** The last piece that needs to be added to the clock body is a **back**

(K), see drawing below. This  $\frac{1}{4}$ "-thick plywood piece is cut to fit the opening in back. And to make it easy to remove, I drilled a small finger hole.

Then to hold the back in place, I used brass turn buttons that are screwed to the back of the sides.

To complete the body of the clock, all that's left to add are four  $\frac{3}{4}$ "-dia. felt pads, see drawing below. But again, I waited to do this until after building the drawer and finishing the clock.

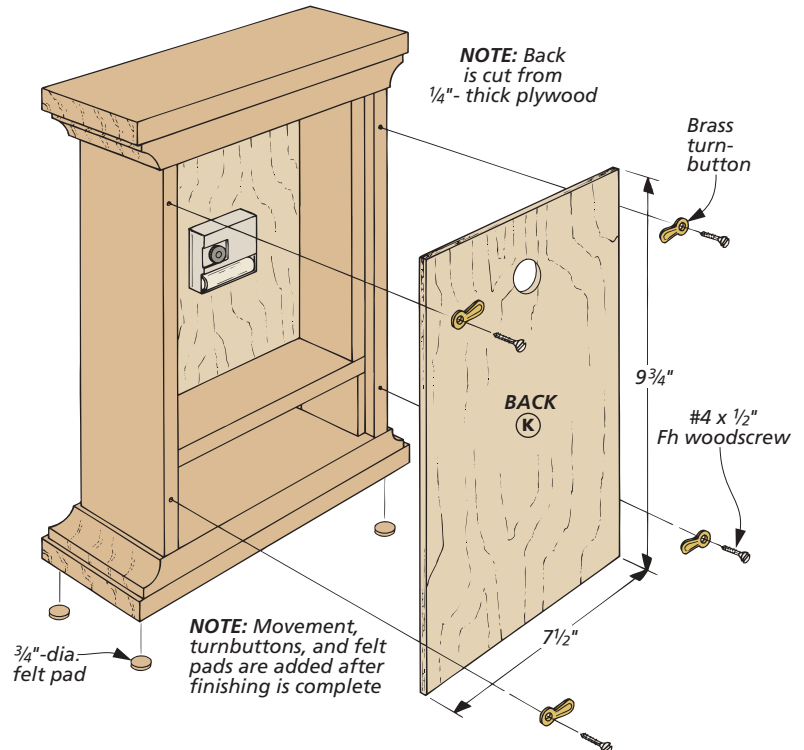
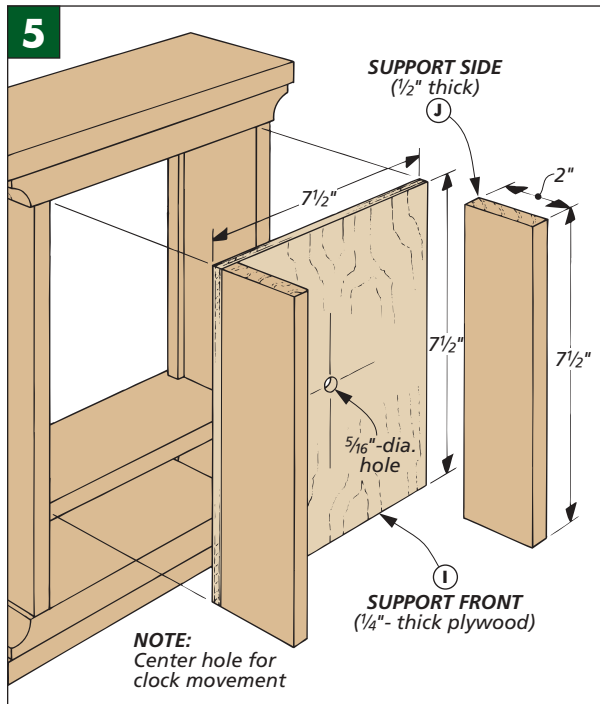

## Drawer

At this point, the only thing left to add is a drawer, see drawing. Like the frame on the clock, this drawer stands slightly proud ( $\frac{1}{8}$ " ), see detail 'b'.

Another thing to note is that this drawer is shallow, so there won't be much binding as it's slid in and out. Because of this, I built the drawer to fit the opening exactly. Then I sanded it until it slid smoothly.

**FRONT.** I started by cutting the  $\frac{1}{2}$ "-thick front (L) to fit the opening, see drawing.

Next, to hold the  $\frac{1}{4}$ "-thick sides, I cut two  $\frac{1}{4}$ "-deep dados on the back face of the front, (These are inset so the sides fit inside the clock.) Then after the dados were cut, I routed a  $\frac{1}{8}$ " roundover on the front's outside edges.

**SIDES & BACK.** Now, the  $\frac{1}{4}$ "-thick sides (M) and back (N) can be cut to size, see drawing.

To hold a  $\frac{1}{4}$ "-thick plywood bottom, I added a  $\frac{1}{8}$ "-deep groove in all the pieces, see detail 'b'. But you don't want this groove visible on the ends of the drawer front, so to prevent this, rout a stopped groove between the dados, see detail 'c'.

Now the bottom (O) can be cut to size, and the drawer can be glued together. (The back simply butts between the sides, see detail 'a'.)

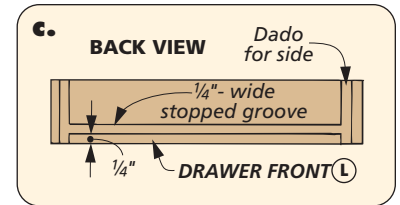
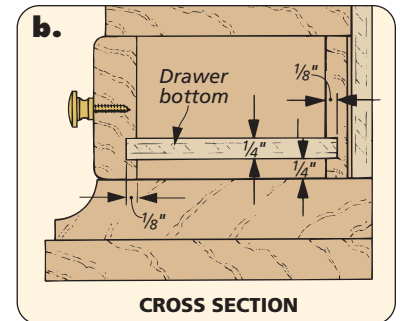
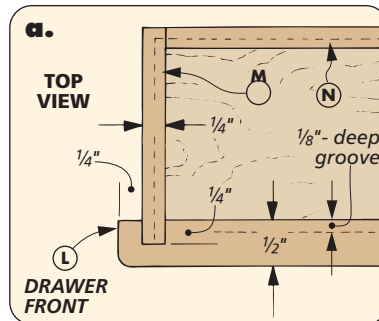
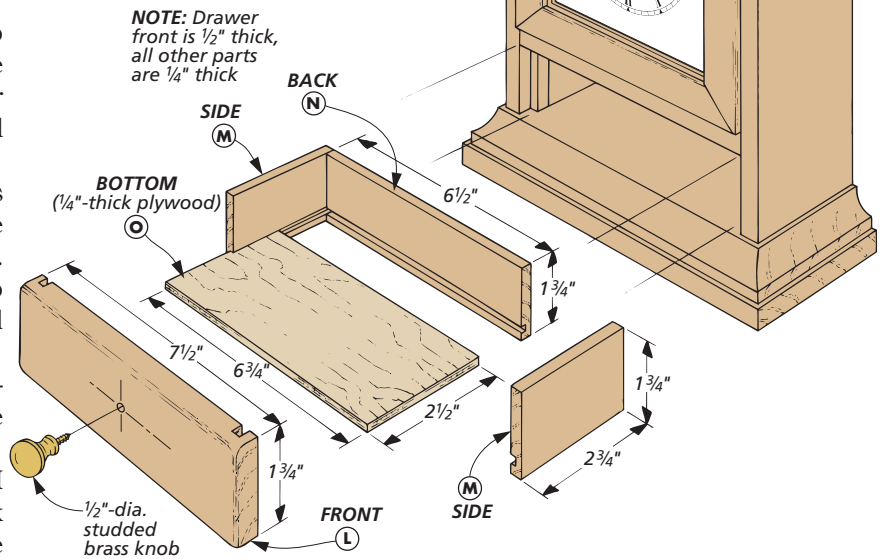

**FINISH.** Then to finish the clock, I highlighted the curly maple with a water-base aniline dye and applied a wipe-on finish.

Now, all that's left to complete the drawer is to add a  $\frac{1}{2}$ "-dia. brass knob to the front. **W**

## MATERIALS

### Clock Body

<b>A</b> Sides (2)	$\frac{1}{2}$ x $3\frac{3}{4}$ - $9\frac{3}{4}$
<b>B</b> Stops (2)	$\frac{1}{2}$ x $\frac{3}{8}$ - 10 rgh.
<b>C</b> Drawer Guides (2)	$\frac{1}{4}$ x $2\frac{1}{4}$ - $1\frac{3}{4}$
<b>D</b> Divider (1)	$\frac{1}{2}$ x 3 - $7\frac{1}{2}$
<b>E</b> Cove Molding (2)	$\frac{3}{4}$ x $3\frac{7}{8}$ - $9\frac{3}{4}$
<b>F</b> Top/Bottom (2)	$\frac{1}{2}$ x 4 - 10
<b>G</b> Frame Pieces (4)	$\frac{1}{2}$ x $\frac{7}{8}$ - 8 rgh.
<b>H</b> Glass Stops (2)	$\frac{1}{2}$ x 2 - 7 rgh.

### MOVEMENT SUPPORT

<b>I</b> Support Front (1)	$\frac{1}{4}$ ply. - $7\frac{1}{2}$ x $7\frac{1}{2}$
<b>J</b> Support Sides (2)	$\frac{1}{2}$ x 2 - $7\frac{1}{2}$
<b>K</b> Back (1)	$\frac{1}{4}$ ply. - $7\frac{1}{2}$ x $9\frac{3}{4}$

### DRAWER

<b>L</b> Front (1)	$\frac{1}{2}$ x $1\frac{3}{4}$ - $7\frac{1}{2}$
<b>M</b> Sides (2)	$\frac{1}{4}$ x $1\frac{3}{4}$ - $2\frac{3}{4}$
<b>N</b> Back (1)	$\frac{1}{4}$ x $1\frac{3}{4}$ - $6\frac{1}{2}$
<b>O</b> Bottom (1)	$\frac{1}{4}$ ply. - $2\frac{1}{2}$ x $6\frac{3}{4}$

## CUTTING DIAGRAM

$\frac{1}{2}$ " x  $4\frac{1}{2}$ " - 48" Maple (1.5 Sq. Ft.)

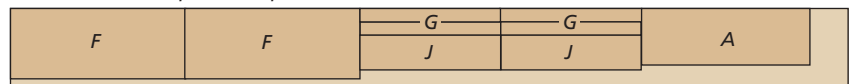

$\frac{1}{2}$ " x  $4\frac{1}{2}$ " - 48" Maple (1.5 Sq. Ft.)

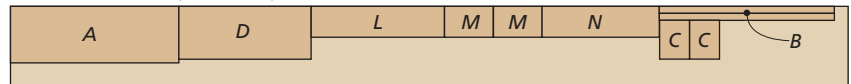

$\frac{3}{4}$ " x  $4\frac{1}{2}$ " - 30" Maple (.94 Bd. Ft.)

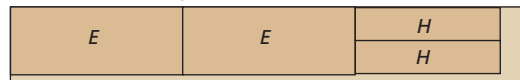

Also needed:  
12" x 16" piece of  
 $\frac{1}{4}$ "-thick plywood

## SUPPLIES

- (8) #6 x  $\frac{1}{4}$ " Fh Woodscrews
- (1)  $\frac{1}{8}$ " Glass ( $6\frac{1}{8}$ " x  $6\frac{1}{8}$ " )
- (1) Quartz Clock Movement
- (1)  $7\frac{1}{2}$ " x  $7\frac{1}{2}$ " Clock Face
- (1 pr.)  $2\frac{3}{4}$ "-Long "Terry" Clock Hands
- (4) Brass Turnbuckles with Screws
- (1)  $\frac{1}{2}$ "-dia. Studded Brass Knob
- (4)  $\frac{3}{4}$ "-dia. Felt Pads