

## Maple coffee table w/ a built-in storage compartment.

The project is straightforward and requires little more than a few power tools and a table saw. We built our table out of maple, but you can use any other commonly available furniture-grade wood and get great results.

### The Top And Legs

The panel for the tabletop is assembled by edge gluing five boards. Begin construction by ripping and crosscutting the stock slightly oversize, 4 1/2 in. wide x 35 in. long.

If you have a plate joiner, use it to cut the slots for six joining plates for each edge joint. Arrange the boards to produce the most attractive grain pattern. And make sure the endgrain growth ring directions alternate between the boards.

Mark centerlines for the slot positions along each joint line, then clamp each board to a flat benchtop while the slots are cut (Photo 1).

Inserting the plates and applying and evenly spreading the glue on eight edges can be difficult to do before the glue begins to set. To make the job easier, preglue the plates in each board. Use a small-nozzle squeeze bottle to apply glue in the slots without getting any on the edges (Photo 2).

To assemble the panel, you'll need four or five long clamps, six smaller clamps and six cauls. This arrangement will apply even pressure across the panel to prevent it from cupping. Rub paste wax on each caul's contact surface to prevent it from sticking to the boards.

Apply glue to the edges and plates, slide the boards together, then apply pressure to the cauls and the long clamps (Photo 3).

Remove the hardened glue that has squeezed from the joint using a scraper, belt sander and finishing sander, in that order. Next, crosscut the panel to finished size.



1--Joint the edges of the boards for the tabletop and cut the slots in them to receive the joining plates.



2--Save glue application time by pregluing the joining plates in their slots. A small-nozzle bottle is handy here.



3--Glue and clamp the top using cauls above and below. Wax the cauls to prevent glue from sticking to them.

Rip and crosscut the legs to size and joint their four faces so they are square to one another and smooth. Lay out the mortise positions on adjacent faces and install a 1/4-in.-dia. straight bit in your plunge router for cutting the mortises. You can use a router edge guide to make the cuts, but the simple jig shown enables you to do the job more quickly and easily. The jig is made of 1/4-in. plywood with cleats attached to the bottom to secure the leg. A removable end cleat allows the leg to be repositioned so that one jig can be used to cut the mortises on both leg faces. On top of the jig, four strips guide the router and stop its travel.

Make mortise cuts in several passes (Photo 4). When the first mortise has been cut on each leg, reposition the jig's end cleat, insert the blank from the other end and proceed to cut the mortise on the adjacent face.

The tapers are cut on the table saw with the aid of a simple step jig. The taper is cut on two adjacent faces with the leg positioned in the first step of the jig. The end of the leg is placed in the second step to cut the two remaining tapers (Photo 5).



3--Glue and clamp the top using cauls above and below. Wax the cauls to prevent glue from sticking to them.



4--Use a jig and a plunge router to cut the leg mortises. The stops are positioned to suit the router's base.



5--Use a stepped jig on the table saw to cut the leg tapers. Each step positions the leg to cut two tapers.

Smooth the inner leg surfaces using a sander, but sand the mortised faces gently by hand to avoid distorting the surface surrounding the mortise. The mortise surface has to remain flat and square.

To complete the legs, set up a 1/16-in.-rad. rounding-over bit in a router table and round the corners (Photo 6).

### Aprons And Assembly

Rip and crosscut the aprons, then set up a dado blade on the table saw to cut the apron tenons. Clamp a stop-block to the miter gauge fence, elevate the blade for a 1/2-in.-deep cut, and cut the tenon in four passes (Photo 7). Next, cut the rabbets for the bottom panel on the inside edges of the four aprons.

After using a chisel to round the ends of the tenons to match the mortises, the table is ready for assembly. Use four clamps and four cauls to assemble the legs and aprons (Photo 8). Apply glue sparingly to the tenons, and draw the assembly together. Check the assembly for square. If necessary, adjust the clamps to make the assembly square.

After the glue has set, use the router with a straight bit to cut the hinge rabbet. To do this, clamp two pieces of scrap flush with the apron's top edge to provide a stable surface for the router. Set the router to make a 5/32-in.-deep cut (Photo 9). Note that the rabbet's 1/2-in. width is critical. It positions the hinge so the top can tilt without striking the leg's corner.

Next, crosscut the piano hinge to fit the rabbet and install it temporarily. Do this by placing the lid on the workbench with the bottom facing up. Then place the table, bottom up, onto the lid and mark the position of the hinge on the lid. Remove the hinge, mark the screw centers, and bore the screw pilot holes. Attach the hinge to the table



6--Round the bottom of the leg corners on the router table. Don't round the top of the leg where it abuts the apron.



7--Use a stopblock clamped to the miter gauge and a dado blade in the table saw to cut the apron tenons.

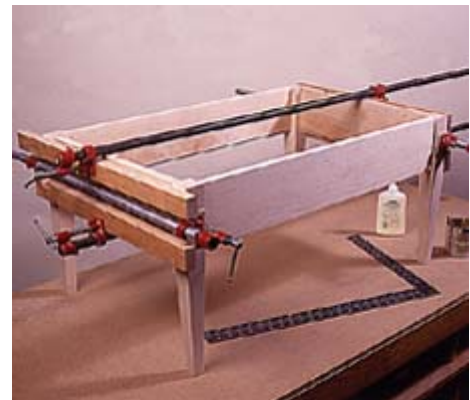

8--Glue and clamp the aprons and legs. Heavy cauls distribute clamping pressure across each apron.

first, then to the lid.

Once the hinge is installed, mark and bore the screw pilot holes for lid supports. Attach the supports to the aprons first, then the lid (Photo 10).

Cut the plywood bottom to size and install it with glue and nails. Also, glue the stiffener strip to the bottom. Remove the lid to allow finishing.

We finished the table with three coats of polyurethane lightly tinted with a few drops of yellow ochre to give it a warm honey color.

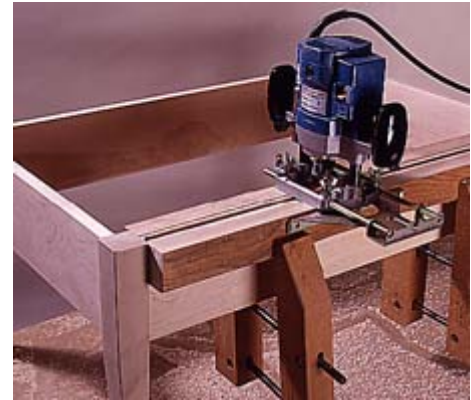

9--Clamp scrap to the rear apron to provide a base for the router, then cut the hinge rabbet using a straight bit.



10--Sequence is important when attaching the top's support hardware. Attach it to the apron first, then the top.

# COFFEE TABLE

17" HIGH X 22" DEEP X 34" WIDE

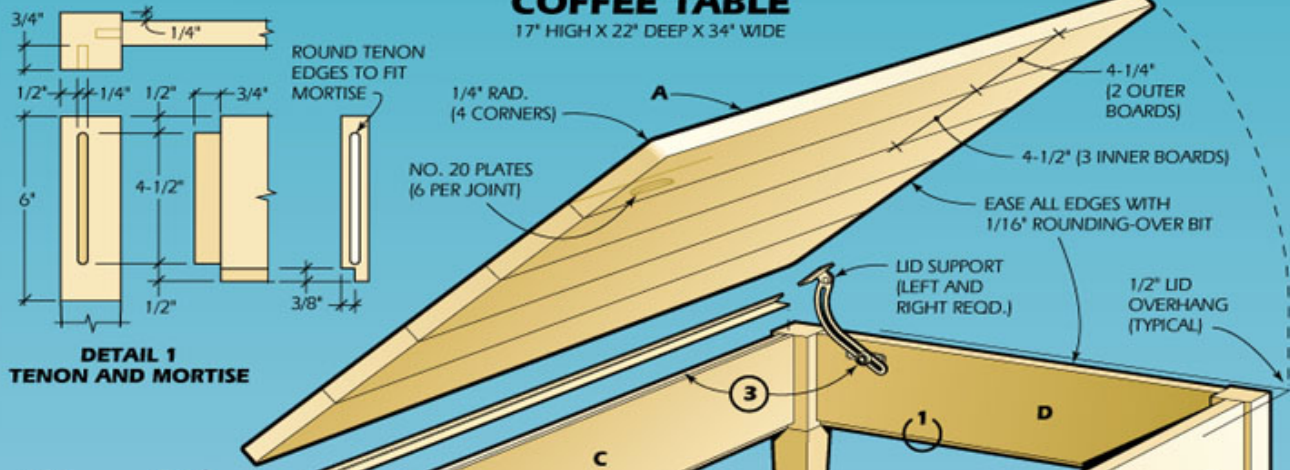

**DETAIL 1 TENON AND MORTISE**

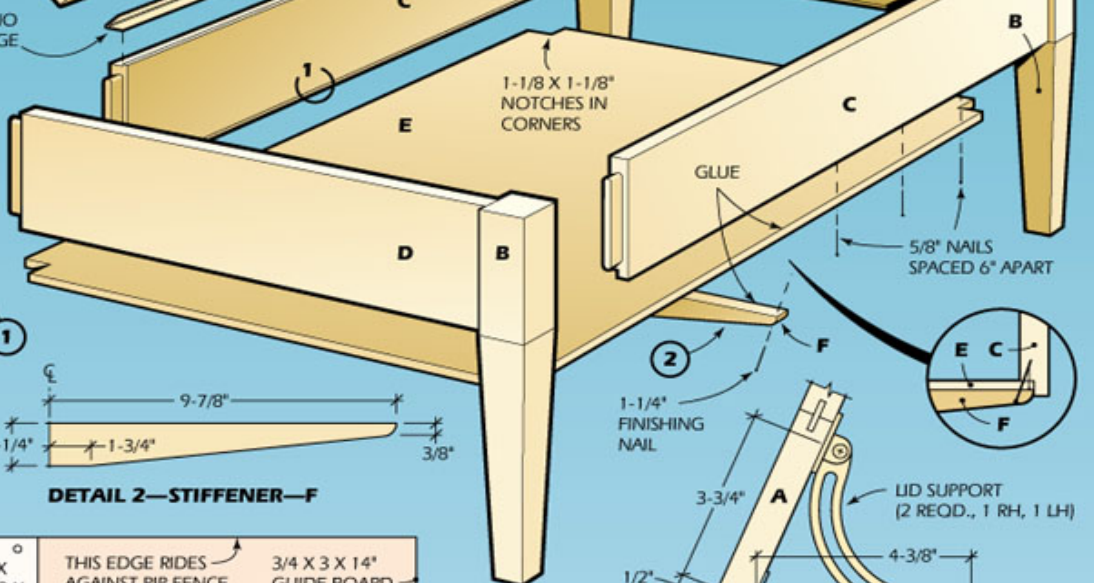
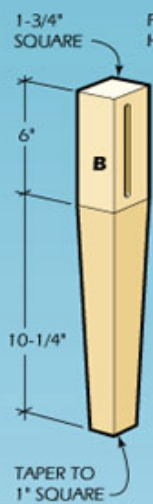

**DETAIL 2—STIFFENER—F**

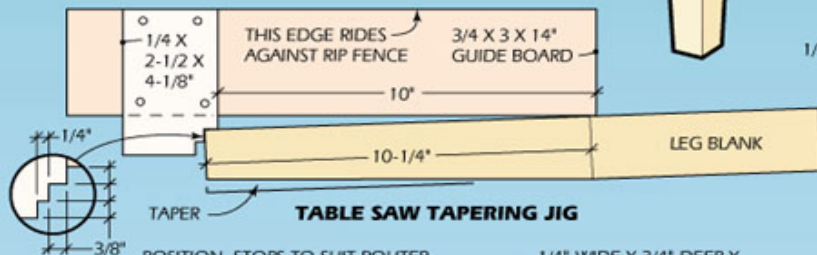

**TABLE SAW TAPERING JIG**

**DETAIL 3—LID SUPPORT**

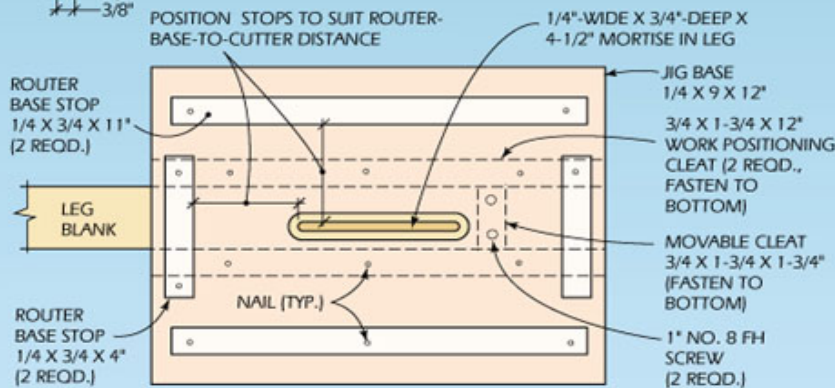

**ROUTER JIG FOR LEG MORTISE**

MATERIALS LIST—COFFEE TABLE

Key	No.	Size and description (use)
A	1	3/4 x 22 x 34" maple (lid)
B	4	1 3/4 x 1 3/4 x 16 1/8" maple (leg)
C	2	3/4 x 5 1/2 x 31" maple (apron)
D	2	3/4 x 5 1/2 x 19" maple (apron)
E	1	1/4 x 19 3/4 x 31 3/4" lauan plywood (bottom)
F	1	3/4 x 1 1/4 x 19 3/4" maple (stiffener)

Misc: Curved friction lid supports, Part Nos. 25619 and 25627, brass 1 1/2-in.-wide x 48-in.-long piano hinge, part 19928: