



Wow! I Made It.com

Sun Lounge with Planters

The combination planter and sun lounge shown here makes an attractive addition to any patio, deck, or pool. A standard chaise—lounge cushion—available almost anywhere—fits the lounge easily, and the planters on both ends are large enough to hold a wealth of cheerful flowers or greenery.



Special Techniques

- Mitering

Materials and Supplies

- 52 linear feet of 1 x 3 pine
- 85 linear feet of 1 x 4 pine
- 1 sheet of 3/4" thick plywood, 4' x 8'

Hardware

- Approx. 500 #6 x 1-1/4" flathead wood screws
- Approx. 30 #6 x 2-1/2" flathead wood screws
- Approx. 60 3d finishing nails
- Eight 3/8"-diameter bolts, at least 3" long, with matching wing nuts

Cutting List

Code	Description	Qty.	Material	Dimensions
A	Side	34	1 x 4 pine	23" long
B	Long Support	4	1 x 3 pine	21" long
C	Medium Support	4	1 x 3 pine	10" long
D	Short Support	16	1 x 3 pine	6: long
E	Base	2	3/4" plywood	See Fig. 2
F	Bottom	2	3/4" plywood	See Fig. 2
G	Trim	!2	1 x 3 pine	Cut to fit (approx. 128" total)
H	Long Frame	2	1 x 4 pine	72: long
I	Short Frame	2	1 x 4 pine	21" long
J	Long Lounge Support	2	1 x 3 pine	70-1/2" long
K	Short Lounge Support	6	1 x 3 pine	19-1/2' long
L	Lounge Platform	1	3/4" plywood	12-1/2" x 70-1/2"

Notes on Materials

If the finished project will be exposed to the elements, choose materials, hardware, glue and a wood finish that are suited for exterior use. We used pressure-treated pine to build our sun lounge, but redwood, western cedar, or other exterior-grade woods make good substitutes. Depending upon the type of wood you buy (each is likely to have a different finish cut), you may need to trim the plywood base and bottom of the planter to fit properly.

Making the Planter Sides

1. The six sides (one long, one medium, and four short) of each planter are different widths and contain different numbers of 1 x 4s. The long side has six 1 x 4s, the medium side has three, and the four short sides have two each. To start building the twelve sides for both planters, first cut thirty-four 23"-long sides (A) from 1 x 4 pine.
2. Cut four long supports (B) from 1 x 3 pine, each measuring 21" long.
3. Lay six of the side pieces (A) on a level surface, positioning them parallel to each other as shown in *Figure 1*. Adjust the spacing between the side pieces (A) so that the total width is exactly 22-1/2". Glue one long support (B) flush with the ends of all six side pieces (A). Note that there is a 3/4" inset at each end of this long support (B). Secure the long support (B) to the side pieces (A) by inserting two 1-1/4" screws through the long support (B) and into each side piece (A).
4. Attach the remaining long support (B), 7-3/4" from the other ends of the six side pieces (A), as shown in *Figure 1* and described in Step 3.

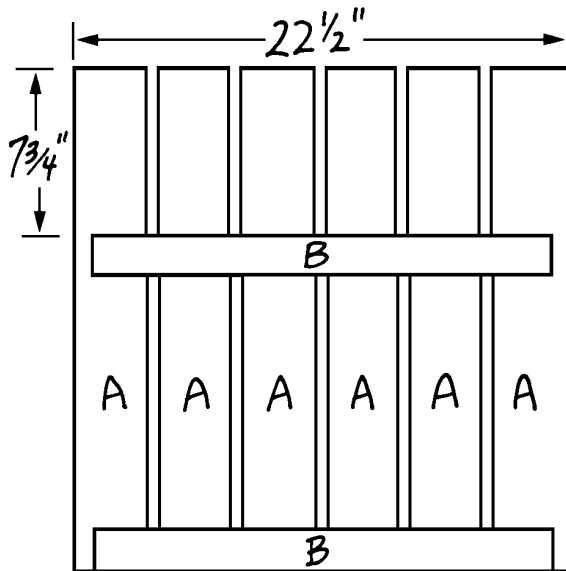

Figure 1

5. Repeat Steps 3 and 4 to construct another long side for the second planter.
6. Cut four 10"-long medium supports (C) from 1 x 4 pine.
7. The medium sides, one for each planter are constructed in the same manner as the long sides—but each one contains only three side pieces (A) and these are spaced differently. Lay three side pieces (A) parallel to each other on a level surface. Adjust the spacing between them so that the total width is exactly 11-1/2". Glue and attach the medium supports (C) as explained in Steps 3 and 4, leaving a 3/4" overlap at each end of each medium support (C).
8. Repeat Step 7 to make another medium side for the second planter.
9. Cut sixteen 6"-long short supports (D) from 1 x 4 pine.

- 10. Lay two side pieces (A) parallel to each other on a level surface. Adjust the spacing between the side pieces (A) so that the total width is exactly 7-1/2". Attach two short supports (D) to the two side pieces (A), following the instructions in Steps 3 and 4.
- 11. Repeat Step 10 seven more times to build all the short sides for both planters.

Adding the Bottoms and Bases

- 1. Using *Figure 2* as a guide cut four identical pieces from 3/4" thick exterior-grade plywood. Two pieces will be bases (E) and two will be bottoms (F) for the planters.

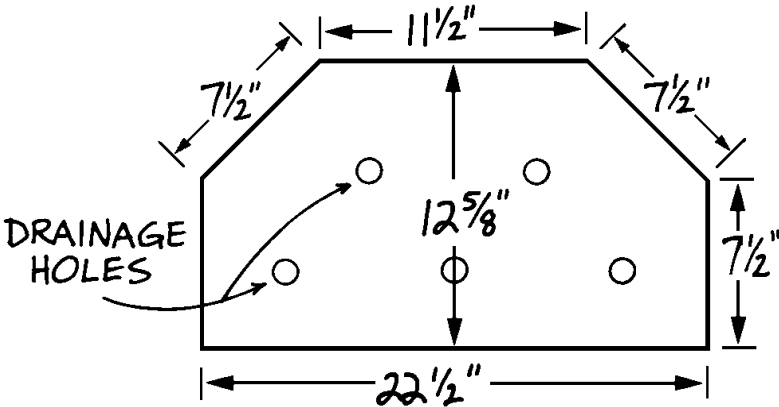

Figure 2

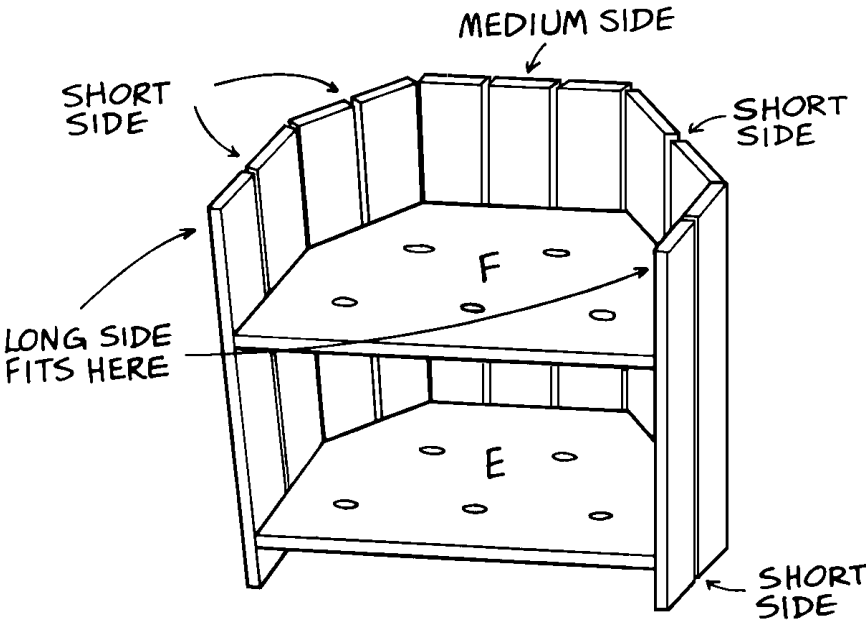

Figure 3

- 2. To allow for drainage, drill five 1"-diameter holes in each base (E) and bottom (F), as shown in *Figure 2*. The exact placement of these holes is not important.

- To attach each base (E) to each side assembly, first position the base over the lower supports (B, C and D), as shown in *Figure 3*. If necessary, trim the base to fit. Glue the base (E) in place and insert 1-1/4" screws through it and into the edges of the supports (B, C, and D), using two screws at each joint. Also insert two 1-1/4" screws through each of the side pieces (A) and into the edges of each base (E).
- Fit a planter bottom (F) into each assembly, as shown in *Figure 3*, making certain that the bottom rests evenly on its supports (B, C, and D) and is level inside the assembly. Glue the bottom (F) in place and insert two 1-1/4" screws through it and into each of the supports (B, C, and D). Also insert two screws through each of the side pieces (A) and into the edges of each bottom.

Completing the Planter

- Measure carefully and cut lengths of trim (G) from 1 x 3 pine to cover the exposed top edges of the planters, as shown in *Figure 4*. Note that some of the trim pieces (G) must be mitered at a 22-1/2-degree angle on one or both ends.

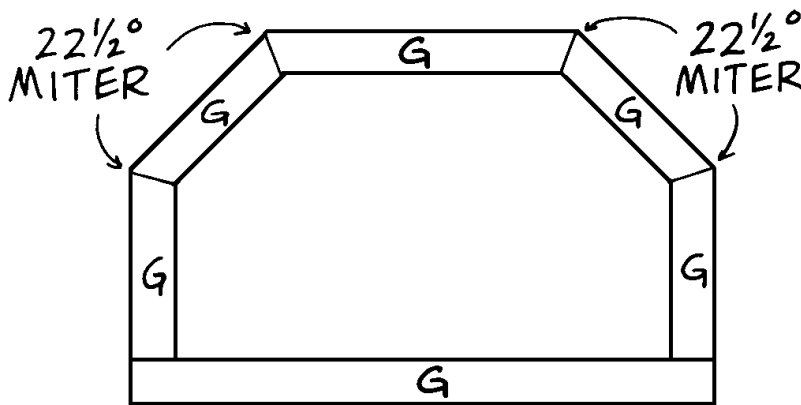

Figure 4

- Flue the trim pieces (G) to the exposed upper ends of the planter side pieces (A). Secure the trim in place with 3d finishing nails spaced about 2" apart.

Constructing the Sun Lounge Frame

- Cut two long frames (H) from 1 x 4 pine, each 72' long.
- Cut two short frames (I) from 1 x 4 pine, each 21' long.
- Place the two long frames (H) on a level surface, parallel to each other, on edge, and 21" apart. Glue the two short frames (I) between the ends of the long frames, as shown in *Figure 5*. Then insert 1-1/4" screws through the long frames (H) and into the ends of the short frames (I), using two screws at each joint.

- Cut two long lounge supports (J), each 70-1/2", from 1 x 3 pine.

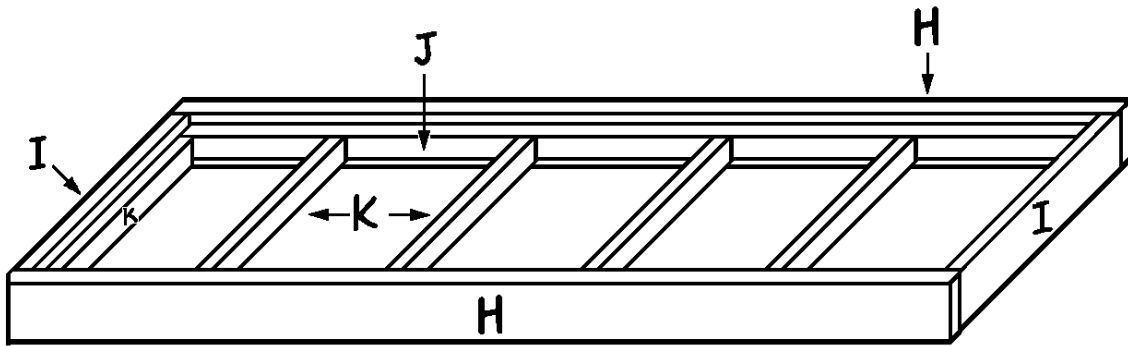

Figure 5

- Glue each long lounge support (J) to the inside of each long frame (H), 3/4" from the edge of the long frame. Secure the parts by inserting 1-1/4" screws spaced 6" apart.
- Cut six short lounge supports (K), each 19-1/2" long, from 1 x 3 pine.
- Glue one short lounge support (K) to the inside of each short frame (I), 3/4" from the top edge of the short frame. Use 1-1/4" screws spaced 6" apart to secure the two short lounge supports in place.
- Glue the remaining four short lounge supports (K) between the two long lounge supports (J), spacing them approximately 13" apart. Insert two 2-1/2" screws through the long frames (H) and the long lounge supports (J) into each end of each short lounge support (K).
- Cut one 19-1/2" x 70-1/2" lounge platform (L) from 3/4" thick plywood.
- Glue the lounge platform (L) to the top edges of the lounge supports (J and K). Insert 1-1/4" screws, spacing them 6" apart, through the lounge platform and into the lounge supports.

Final Assembly and Finishing

- The two planters must now be connected to the lounge. In order to determine the correct placement, first take a look at the project photo. Note that we attached our lounge so that the cushion would rise slightly above the planters. Place your cushion on top of the lounge and measure the distance from the bottom of the lounge frame to the top of the cushion. Using this measurement as a guide, mark across the long side of each planter to indicate where you'd like to locate the bottom of the lounge. Make sure that the mark you've just made is no more than 9" down from the upper face of the planter trim. If you go lower than 9" the bolts you insert to attach the lounge to the planters will end up being below the base (F), and you won't be able to reach them in order to tighten the wing nuts onto them.

2. Drill four equally-spaced holes, slightly larger in diameter than the bolts, through each short lounge support (K) and the short frame (I) to which it's attached.
3. Enlist the services of a helper and holding the lounge at the marked location on each planter, mark the corresponding hole locations on one long side of each planter. Then drill bolt holes in the planter side at the marked locations.
4. Fit the 3/8" bolts through the drilled holes in the lounge and through the long side of each planter. Add the wing nuts, tightening the nuts firmly to connect the lounge securely.
5. You may have noticed that the lounge in the photo has additional lounge supports underneath it. These really aren't necessary. We added them because we have groups of very large teenage boys involved in horseplay around our pool. If you'd like to add the supports, just attach a length of 1 x 2 to each planter side, 3/4" below the lower edges of the lounge. Then slip two or three 70" lengths of 1 x 4 between these supports and the bottom of the lounge.
6. Sand the completed project thoroughly.
7. Stain or paint the sun lounge and planters the color of your choice.

Build other exciting indoor and outdoor projects from
www.wowimadeit.com !

