



BACKYARD PROJECTS

from

Georgia-Pacific



GARDEN BENCH

GARDEN BENCH

MATERIALS LIST

Lumber to be pressure treated
Southern Pine

- 2 2x6 @ 8'- 0" cut to:
 - 2 @ 17" SIDE APRONS, shape tops and scallop bottom edge
 - 2 @ 6" ARMREST SUPPORT BRACKETS, shape outside curves as shown
 - 1 @ 49" BACKREST, shape top as shown
 - 1 @ 40¹/₂" FRONT APRON, scallop bottom
 - 1 @ 40¹/₂" BACK APRON, scallop bottom
- 2 2x8 @ 6'- 0" cut to:
 - 2 @ 26" ARMRESTS, shape outside edges as shown
 - 2 @ 36" BACKLEGS, cut to 3" wide angling the top part as shown at a +/-19° angle from the vertical
- 5 2x4 @ 8'- 0" cut to:
 - 1 @ 40¹/₂" BACKRAIL, plane to 1¹/₂" x 3"
 - 2 @ 23¹/₄" FRONT LEGS, plane to 1¹/₂" x 3"
 - 2 @ 20" SIDE SEAT SUPPORTS, shape tops to form a seat curve as shown
 - 2 @ 40¹/₂" FRONT & BACK SEAT SLATS
 - 4 @ 43¹/₂" SEAT SLATS
- 1 1x4 @ 8'- 0" cut to:
 - 8 @ 12" BACK SLATS
- 4 @ 1/4"x3¹/₂" galvanized LAG SCREWS
- 8 @ 3/8"x3¹/₂" galvanized CARRIAGE BOLTS with WASHERS & NUTS
- 60+/- 4d 2¹/₂" DECKING SCREWS
- 1 tube waterproof construction ADHESIVE

INSTRUCTIONS

1. Cut all pieces to final size, sculpt curves as necessary and sand edges smooth.
2. Attach side seat supports to front and back legs using carriage bolts.
3. Screw aprons to front, back and sides.
4. Screw seat slats to side seat supports.
5. Rabbet backrest bottom edge and backrail top edge to admit backslats, glue in place.
6. Notch backrest & glue to rear legs; screw backrest & backrail to rear legs.
7. Notch under armrests; glue and insert front legs (screws optional).
8. Lag armrests to rear legs.
9. Screw armrest support brackets in place.
10. Paint.

Georgia-Pacific



Georgia-Pacific Corporation makes no warranties expressed or implied regarding this plan and specifically disclaims the warranties of merchantability and fitness for a particular purpose. Check with an architect or a building expert to make sure that this plan is appropriate to your situation and meets local building codes. Read carefully the consumer information sheet on pressure treated wood before starting construction.

GARDEN BENCH

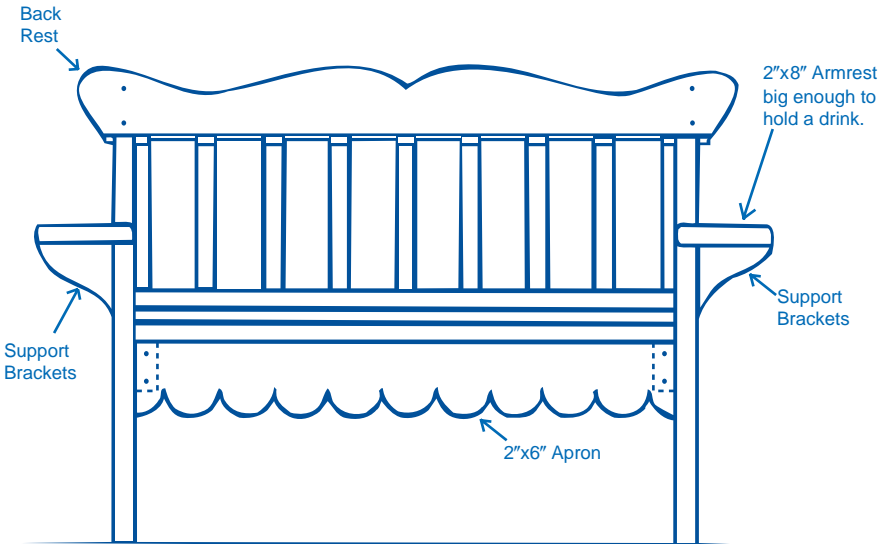

FRONT ELEVATION

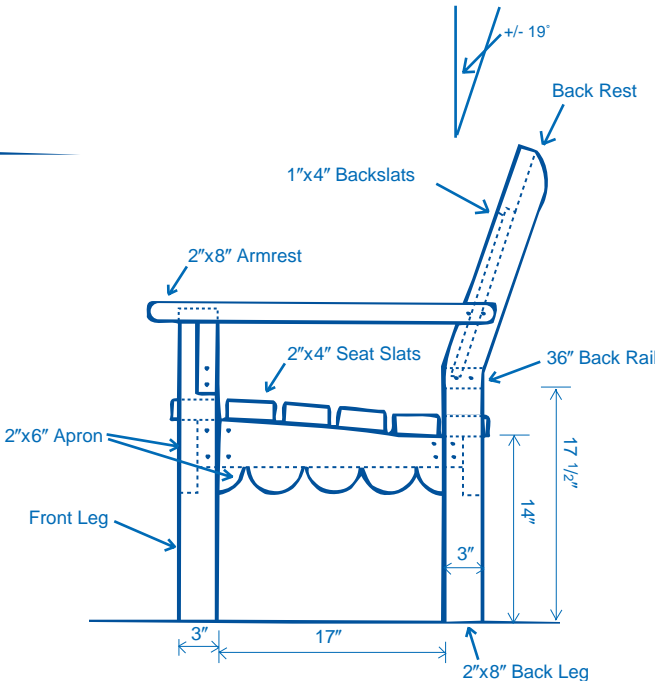

SIDE ELEVATION

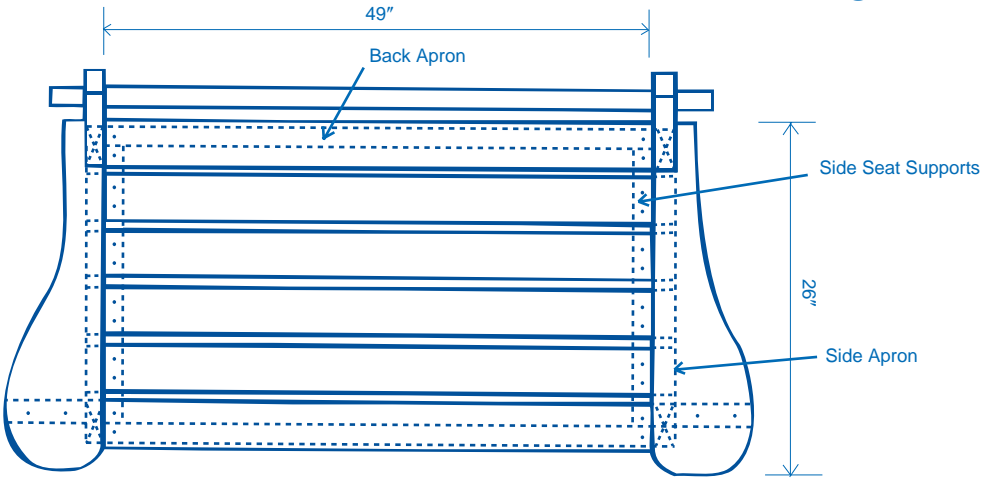

PLAN VIEW

GARDEN BENCH

Consumer information approved by the U.S. Environmental Protection Agency For Inorganic Arsenical Pressure Treated Wood.

CONSUMER INFORMATION

This wood has been preserved by pressure-treatment with an EPA-registered pesticide containing inorganic arsenic to protect it from insect attack and decay. Wood treated with inorganic arsenic should be used only where such protection is important.

Inorganic arsenic penetrates deeply into and remains in the pressure-treated wood for a long time. Exposure to inorganic arsenic may present certain hazards. Therefore, the following precautions should be taken both when handling the treated wood and in determining where to use or dispose of the treated wood.

USE SITE PRECAUTIONS

Wood pressure-treated with waterborne arsenical preservatives may be used inside residences as long as all sawdust and construction debris are cleaned up and disposed of after construction. Do not use treated wood under circumstances where the preservatives may become a component of food or animal feed. Examples of such sites would be structures or containers for storing silage food.

Do not use treated wood for cutting-boards or countertops.

Only treated wood that is visibly clean and free of surface residue should be used for patios, decks, and walkways.

Do not use treated wood for construction of those portions of beehives which may come into contact with the honey.

Treated wood should not be used with public drinking water, except for uses involving incidental contact such as docks and bridges.

HANDLING PRECAUTIONS

Dispose of treated wood by ordinary trash collection or burial. Treated wood should not be burned in open fires or in stoves, fireplaces, or residential boilers because toxic chemicals may be produced as part of the smoke and ashes. Treated wood from commercial or industrial use (e.g., construction sites) may be burned only in commercial or industrial incinerators or boilers in accordance with state and Federal regulations.

Avoid frequent or prolonged inhalation of sawdust from treated wood. When sawing and machining treated wood, wear a dust mask. Whenever possible, these operations should be performed outdoors to avoid indoor accumulations of airborne sawdust from treated wood.

When powersawing and machining, wear goggles to protect eyes from flying particles. Gloves can provide extra protection against splinters and freshly treated wet wood. Allow freshly treated wet wood to dry thoroughly before handling. Follow good personal hygiene practices in the shop and on the job. After working with the wood, and before eating, drinking, and use of tobacco products, wash exposed areas thoroughly. If preservatives or sawdust accumulates on clothes, launder before reuse. Wash work clothes separately from other household clothing.



WHENEVER YOU BUILD WITH TREATED WOOD PRODUCTS FROM GEORGIA-PACIFIC, BUILD CORRECTLY.

Whatever you build with Georgia-Pacific treated wood products should last a long time. So, it makes good sense to build in a craftsmanlike manner. Here are some helpful tips to make your job easier and look better.



USE GALVANIZED FASTENERS.

Use galvanized or stainless nails, screws, or bolts when working with pressure treated wood. These types of fasteners are corrosion-resistant and should minimize rust stains on your project.

NAIL BARK SIDE UP.

Always nail boards bark side up (annual rings arc upward) to reduce cupping. Nail thin boards to thicker boards to maintain structural integrity.



DRILL PILOT HOLES.

Especially when nailing near the edge or end of a board, it's a good idea to drill pilot holes for your fasteners.



BUTT BOARDS TIGHTLY.

Butt decking boards together firmly. As drying occurs, some shrinkage can be expected.

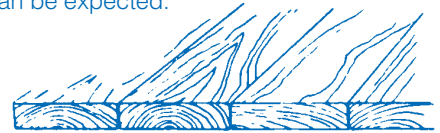

APPLY A WEATHER-RESISTANT FINISH...

Any exposed wood, pressure treated or not, should be protected from the weather. Application of a finish coat of clear water repellent or semi-transparent stain will help to minimize warping, checking, or splitting. The finish coat should be applied to pressure treated wood as soon as it is dry to the touch, and immediately to untreated wood. (Option: stain or water repellent may be applied when the wood is surface dry.)



Georgia-Pacific
Treated Lumber

*The best treated lumber you can buy,
from the name you trust.*
www.gp.com

©1999 Georgia-Pacific Corporation. All rights reserved.
Printed in the U.S.A. 6/99. Lit. Item #121782.