

6 TRICKS FOR GLUING UP SEAMLESS, FLAT PANELS
SHARPENING CHISELS & PLANES: A COMPLETE AND SIMPLE GUIDE

APRIL 2003
ISSUE #133

Popular Woodworking

ARTS & CRAFTS BOOKCASE

Stickley Design
is Easy to Build,
Made to Last

4 SOLID JOINTS FOR
Blanket Chests
and Cabinets

PLUS

- Figured Walnut Photo Album
- 4 Ways to Cut Tighter Dados
- Colonial Chimney Cupboard
- Why You Should Try Dyes

www.popwood.com
\$4.99 U.S. \$7.99 CAN



Ht: 0.816", Wd: 1.4872",

Mag: 80% BWR: 1
71486 0135 51 6



It's
our
20th
anniversary
but
you
get
the
gifts!



Choose The Knapp

Absolutely the best combination machine, custom-made to your precise specifications. Call today to order your free demonstration video and see why the Knapp multi-task machine performs more like a metal machine.

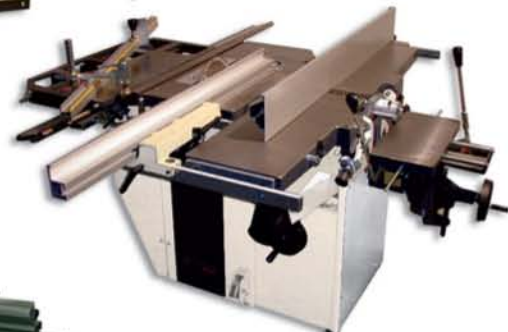

Choose the X31

The revolutionary X31 set new performance standards when we introduced it 14 years ago. Packed with features and powered by three separate 3 HP motors, home woodworkers can achieve results comparable with the best, fully equipped professional shops.



Choose the New NX31 or NLX

Get professional features you want at prices any hobbyist can afford with Laguna Tools' latest combination machine innovations. Built to meet our meticulous quality control standards, these machines have the five precision tools master woodworkers demand: 12" jointer with 12" planer to dimension lumber, 3 HP shaper, 3 HP cast-iron mortiser, 12" table saw with 60" or more sliding table panel saw, 10-second change-over time, three separate 3 HP motors, and a separate professional panel saw for improved, precise cutting (NX31 only).



FREE

FREE 5' EUROPEAN WORKBENCH



VALUE \$895.

FREE ACCESSORY PACKAGE



VALUE \$1,130

FREE LT 14 BANDSAW



VALUE \$895.

LAGUNA TOOLS

YOU BUILD WITH WOOD, WE BUILD WITH TRUST.

17101 Murphy Avenue T- 949.474.1200
Irvine, CA 92614 F- 949.474.0150
www.lagunatools.com E- mail@lagunatools.com

Offer valid for machines purchased and shipped between January 1 and July 31, 2009. Subject to availability.

CALL FOR FREE VIDEO
800.234.1976

contents

Popular Woodworking

TOOLS AND TECHNIQUES



18 Thumb-saver for Scraper Users

TRICKS OF THE TRADE

Scrapers get hot when you use them – hot enough to blister. This simple jig keeps your thumbs cool. Also, convert a junk-store block plane into a rabbeting block plane. And build storage using PVC pipe.

28 Clifton Bench Planes

ENDURANCE TEST

We stripped down, tuned up and used the heck out of four Clifton bench planes. Do they deserve a spot in your shop?

30 DeWalt's Newest Router Kit

TOOL TEST

DeWalt was one of the last tool makers to manufacture a router kit with both plunge and fixed bases. It was worth the wait. Also, Senco has new compressor and nailer kits. We test out Glen-Drake's new chisel hammers.



30 DeWalt's Newest Router Kit

TOOL TEST

DeWalt was one of the last tool makers to manufacture a router kit with both plunge and fixed bases. It was worth the wait. Also, Senco has new compressor and nailer kits. We test out Glen-Drake's new chisel hammers.

38 Precision Stop

INGENIOUS JIGS

You might wonder why we published plans for a block of wood with a hole in it. Build it, and you'll wonder how you ever got by without it in your shop.

By Nick Engler



40 Dado Joints

POWER-TOOL JOINERY

Dados are the heart of solid casework. We show you four good ways to cut this joint quickly, accurately and safely using a router, router table and table saw.

By Bill Hylton

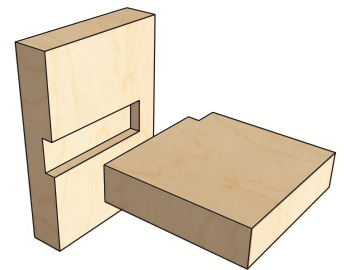

46 Sharpen Plane Irons & Chisels

Learning to sharpen your tools will change your woodworking. Here are the basics – with nothing left out – that will set you on the path to sharpening all your edge tools.

63 Before the ER

You're injured. Here's how to quickly assess the situation and decide if you need a ride to the emergency room.

By Dr. D. Michael Jervis

71 Gluing up Panels

Unless you're a lucky soul with 24"-wide walnut in the rack, you need to learn the rules to making perfect panels.

By Lonnie Bird



Popular Woodworking (ISSN 0884-8823, USPS 752-250) is published seven times a year in February, April, June, August, October, November and December by F&W Publications Inc. Editorial and advertising offices are located at 4700 E. Galbraith Road, Cincinnati, OH 45236; tel.: 513-531-2222. Unsolicited manuscripts, photographs and artwork should include ample postage on a self-addressed, stamped envelope (SASE); otherwise they will not be returned. Subscription rates: A year's subscription (7 issues) is \$28; outside of U.S. add \$7/year • Canada Publications Mail Agreement No. 40025316. Canadian return address: 2744 Edna St., Windsor, ON N8Y 1V2 • Copyright © 2003 by Popular Woodworking. Periodicals postage paid at Cincinnati, Ohio, and additional mailing offices. Postmaster: Send all address changes to Popular Woodworking, P.O. Box 5369, Harlan, IA 51593 Canada GST Reg. # R122594716 • Produced and printed in the U.S.A.



ON THE COVER

Built for magazines or books, this small storage tower looked awful in the Stickley catalog. We reproduced the original in all its glory and found out that it's well-designed and easy-to-build.

Cover photo by Al Parrish

IN EVERY ISSUE

8 Out on a Limb
A Great Time for Home Woodworking

10 Letters
Mail from readers

14 Q & A
We answer readers' most difficult questions

91 Caption the Cartoon
Win a Makita drill

92 Flexner on Finishing
Colors to Dye For

96 Out of the Woodwork
Plane Night by Craig Bentzley

PROJECTS

52 Gustav Stickley Magazine Cabinet

Reproduce a Stickley classic using plans developed from a vintage original. Subtle tapers and gentle curves lighten the look of this simple and useful bookshelf.

60 Heirloom Photo Album

A special board (scraps, probably) and some hardware are all you need to make photo album covers worthy of your best memories. You'll take scrapbooking to a whole new level.

64 Classic Wardrobe

The best way to build a big cabinet is to avoid building a big cabinet. Instead, you should build smaller ones and attach them using waist moulding. Here's how.

By Troy Sexton



74 Colonial Chimney Cupboard

The perfect cabinet for those small nooks and crannies of your house. If you can sacrifice a few square feet of floor, you'll get a tower of storage for china or books.

By Glen Huey

80 Four Joints for Box Making

Blanket chests are great projects for beginners because they're a lesson in the fundamentals of box building. We present four ways to build a traditional and a contemporary blanket chest.





**FIRST WE RAISED THE BAR.
THEN WE LOWERED THE PRICE.**



*Due to heavy demand,
quantities are limited.
Check with your distributor
for availability.*

Introducing the innovative JET 10" SuperSaw.

It's the attention to detail that sets this saw apart, so let's cut to the chase. Compared to the competition, the JET 10" SuperSaw features two solid cast-iron wings instead of stamped steel giving it twice the cast-iron work surface of other saws. Its optional sliding table boasts a miter gauge with T-slot and a handy

angle reference guide. It has a brand-new fence with magnified cursor, micro adjustment and 4 T-slots for jigs. And it's heavier than the competition, with a fully enclosed cabinet, larger dust port, and wider stance that makes it far more stable. The SuperSaw is also the only saw on the planet that includes an on/off switch that can

be positioned anywhere along the fence rail, plus thoughtful details like a reset button and power indicator light.

So to review, the JET 10" SuperSaw has better specs, more features, and a warranty that's twice as long. Oh, and did we mention it costs less? Visit your JET distributor for more details.



*For a free 23-minute video
showing everything the SuperSaw can do,
call 1-800-274-6848 or visit jettools.com.*

JET

Powermatic, Performax and JET. A Family of Brands.

CIRCLE NO. 128 ON FREE INFORMATION CARD.



MADE IN
USA

benchdog.com

For the serious woodworker and professional.

ProTop
COMPLETE

(p/n FTB400)

ProTop Complete floor standing system includes our 36" **ProFence** router fence, a **ProTop Standard** router top and a **ProTop Cabinet**. (Shown with optional **Drawer Bank** and **Cab-Loc** mobile leveling system)



ProLift

Router Adjustment System (p/n PL1002)

Perfect for the Porter-Cable 7518 router and 4.2" diameter fixed base router motors (except plunge routers). Fits 3.5" dia. and smaller fixed base motors with adapters.

FREE CATALOG 1-800-786-8902

CIRCLE NO. 106 ON FREE INFORMATION CARD.

Veritas® Toolbox Trays



A step up from the old warped cookie sheets and muffin tins, and more practical than a mechanic's tool cabinet, these trays let you build a fine looking tool cabinet that exactly suits your needs. The cabinet carcass is simple and quick to build, needing only a series of 1/4" deep kerfs 1 1/4" apart. The 2" drawer is interchangeable with two 1" drawers (or vice versa). Drawers are 10 3/8" wide and 12" long. Made from 0.027" thick formed steel and painted with red powder coat for strength and durability. Patent pending.

Box of 5 Toolbox Trays: (Also sold individually)

05K98.15 Five 1" Trays \$19.95
05K98.25 Five 2" Trays \$23.50

Shipping and
NY sales tax extra.

1-800-683-8170

Lee Valley & Veritas®

Lee Valley Tools Ltd., 814 Proctor Avenue, Ogdensburg, New York 13669

Shop online:

www.leevalley.com

Popular Woodworking®

April 2003, Vol. 23, No. 2
popularwoodworking.com

Editorial Offices 513-531-2690

Editor & Publisher **Steve Shaney**
ext. 1238 • steve.shaney@fwpubs.com

Art Director **Linda Watts**
ext. 1396 • linda.watts@fwpubs.com

Senior Editor **David Thiel**
ext. 1255 • david.thiel@fwpubs.com

Senior Editor **Christopher Schwarz**
ext. 1407 • chris.schwarz@fwpubs.com

Assistant Editor **Kara Gebhart**
ext. 1348 • kara.gebhart@fwpubs.com

Project Illustrator **John W. Hutchinson**

Photographer **Al Parrish**

Contributing Editors

Nick Engler
Bob Flexner
Glen Huey
Troy Sexton

President-Magazines **Roger Case**

Executive Vice President **Jim Gleim**

Editorial Director **David Fryxell**

CIRCULATION

Lynn Kruezkamp, Group Circulation Manager
Jennifer Shaffer, Circulation Manager

PRODUCTION

Barbara Schmitz, Vice President
Vicki Whitford, Production Supervisor

ADVERTISING

Advertising Director

Don Schroder

331 N. Arch St., Allentown, PA 18104
Tel. 610-821-4425; Fax 610-821-7884
d.schroder@verizon.net

Classified Advertising Sales

Joan Wright, Tel. 800-388-1820

jwrightperry@aol.com

Advertising Production Coordinator

Debbie Thomas, Tel. 513-531-2690 ext. 1219
debbie.thomas@fwpubs.com

SUBSCRIPTION SERVICES Subscription inquiries, orders and address changes can be made at popwood.com (click on Subscriber Services). Or by mail: Popular Woodworking, P.O. Box 5369, Harlan, IA 51593 or call 800-888-6880. Include your address with all inquiries. Allow 6 to 8 weeks for delivery.

NEWSSTAND DISTRIBUTION Curtis Circulation Co., 730 River Rd., New Milford, NJ 07646

ATTENTION RETAILERS:

To carry Popular Woodworking in your store, call RetailVision at 800-381-1288 ext. 6050 or write RetailVision, 23 Pond Lane, Middlebury VT 05753.

Back issues are available for \$7 (\$9 Canada; \$11 other foreign). Send check or money order to: Popular Woodworking/F&W Publications Products, P.O. Box 2031, Harlan IA, 51593; or call 888-419-0421. Please specify publication, month and year.

CIRCLE NO. 134 ON FREE INFORMATION CARD.



MADE IN
USA

benchdog.com

For the serious woodworker and professional.

ProTop
COMPLETE

(p/n FTB400)

ProTop Complete floor standing system includes our 36" **ProFence** router fence, a **ProTop Standard** router top and a **ProTop Cabinet**. (Shown with optional **Drawer Bank** and **Cab-Loc** mobile leveling system)



ProLift

Router Adjustment System (p/n PL1002)

Perfect for the Porter-Cable 7518 router and 4.2" diameter fixed base router motors (except plunge routers). Fits 3.5" dia. and smaller fixed base motors with adapters.

FREE CATALOG 1-800-786-8902

CIRCLE NO. 106 ON FREE INFORMATION CARD.

Veritas® Toolbox Trays



A step up from the old warped cookie sheets and muffin tins, and more practical than a mechanic's tool cabinet, these trays let you build a fine looking tool cabinet that exactly suits your needs. The cabinet carcass is simple and quick to build, needing only a series of 1/4" deep kerfs 1 1/4" apart. The 2" drawer is interchangeable with two 1" drawers (or vice versa). Drawers are 10 3/8" wide and 12" long. Made from 0.027" thick formed steel and painted with red powder coat for strength and durability. Patent pending.

Box of 5 Toolbox Trays: (Also sold individually)

05K98.15 Five 1" Trays \$19.95
05K98.25 Five 2" Trays \$23.50

Shipping and
NY sales tax extra.

1-800-683-8170

Lee Valley & Veritas®

Lee Valley Tools Ltd., 814 Proctor Avenue, Ogdensburg, New York 13669

Shop online:

www.leevalley.com

Popular Woodworking®

April 2003, Vol. 23, No. 2
popularwoodworking.com

Editorial Offices 513-531-2690

Editor & Publisher **Steve Shaney**
ext. 1238 • steve.shaney@fwpubs.com

Art Director **Linda Watts**
ext. 1396 • linda.watts@fwpubs.com

Senior Editor **David Thiel**
ext. 1255 • david.thiel@fwpubs.com

Senior Editor **Christopher Schwarz**
ext. 1407 • chris.schwarz@fwpubs.com

Assistant Editor **Kara Gebhart**
ext. 1348 • kara.gebhart@fwpubs.com

Project Illustrator **John W. Hutchinson**

Photographer **Al Parrish**

Contributing Editors

Nick Engler
Bob Flexner
Glen Huey
Troy Sexton

President-Magazines **Roger Case**

Executive Vice President **Jim Gleim**

Editorial Director **David Fryxell**

CIRCULATION

Lynn Kruetzkamp, Group Circulation Manager
Jennifer Shaffer, Circulation Manager

PRODUCTION

Barbara Schmitz, Vice President
Vicki Whitford, Production Supervisor

ADVERTISING

Advertising Director

Don Schroder

331 N. Arch St., Allentown, PA 18104
Tel. 610-821-4425; Fax 610-821-7884
d.schroder@verizon.net

Classified Advertising Sales

Joan Wright, Tel. 800-388-1820

jwrightperry@aol.com

Advertising Production Coordinator

Debbie Thomas, Tel. 513-531-2690 ext. 1219
debbie.thomas@fwpubs.com

SUBSCRIPTION SERVICES Subscription inquiries, orders and address changes can be made at popwood.com (click on Subscriber Services). Or by mail: Popular Woodworking, P.O. Box 5369, Harlan, IA 51593 or call 800-888-6880. Include your address with all inquiries. Allow 6 to 8 weeks for delivery.

NEWSSTAND DISTRIBUTION Curtis Circulation Co., 730 River Rd., New Milford, NJ 07646

ATTENTION RETAILERS:

To carry Popular Woodworking in your store, call RetailVision at 800-381-1288 ext. 6050 or write RetailVision, 23 Pond Lane, Middlebury VT 05753.

Back issues are available for \$7 (\$9 Canada; \$11 other foreign). Send check or money order to: Popular Woodworking/F&W Publications Products, P.O. Box 2031, Harlan IA, 51593; or call 888-419-0421. Please specify publication, month and year.

CIRCLE NO. 134 ON FREE INFORMATION CARD.

It's a Great Time for Home Woodworking

Just in case you haven't noticed, it's a really great time to be a woodworker. And there are lots of reasons. In fact, I honestly believe there is something of a renaissance going on all around us, and we just may be too close to actually see it.

I base my thinking on a number of observations which, although unrelated on the surface, actually add up to my conclusion. During the past few years I've noticed tremendous growth in the variety of woodworking going on. Turning has had explosive growth, and the quality of work being produced is impressive. Also there are growing numbers of musical instrument makers all over the United States. And the level of cabinet- and furniture-making is rising. Scroll saw and in-tarsia work has matured.

What's significant though is not that there are a handful of superb woodworkers in these and other areas of woodworking – there always has been. No, what's impressive, I believe, is that there are *so many* talented craftsmen now, and the overall quality of work is rising. You can see it at woodworking shows, galleries and student work from the remaining high schools and colleges that offer woodworking classes.

But there is other evidence, too. Just look at the quality and innovation of some woodworking tools and equipment being offered today. Whether it's competition among manufacturers or more sophisticated and demanding customers, equipment available today, even at exceptionally good values,

is remarkable. For example, there are major innovations in band-saw design, a machine that had seen little change in decades. New models feature bigger motors, better guides and quick-tension release mechanisms. Some band saws, like the so-called "European" design, are new in every respect. Woodturning lathes, like the Oneway, models from Jet and Powermatic, and the steel bed from Delta, offer impressive new designs or features.

Then there's the quiet revolution going on in the heretofore sleepy world of hand tools. Not so many years ago it was almost impossible to buy a good, new hand plane. Today, we have beautiful looking and performing metal planes from Lie-Nielsen Toolworks, Clifton, Veritas and Ashley Iles. There are even wooden planes of exceptional quality being made by Clark & Williams and Knight Toolworks. Other companies offer quality planes you build from a kit.

Even plane blades are becoming better with the introduction of A2 steel and cryogenic blade treatment.

Woodworking is maturing, and it's producing wonderful results. Just think about it the next time you are in your shop fussing over some project detail – you're part of the renaissance too! **PW**



Steve Shanesy
Editor and publisher

SUBSCRIBER ALERT!

Subscribers to POPULAR WOODWORKING have been receiving renewal notifications, subscription offers and invoices from companies called Publishers Services Exchange, Associated Publishers Subscription Services and Seascope Publishers Network.

Publishers Services Exchange of Medford, Ore.; Associated Publishers Subscription Services of White City, Ore., or Bedford, Mo.; or Seascope Publishers Network of Chicago, are unauthorized representatives or agents of

POPULAR WOODWORKING. These organizations are selling a three-year subscription at a price higher than the price POPULAR WOODWORKING currently offers.

Please forward any correspondence you receive from Publishers Services Exchange, Associated Publishers Subscription Services or Seascope Publishers Network to the office of the Publisher of POPULAR WOODWORKING, ATTN: Circulation Department, 4700 E. Galbraith Road, Cincinnati, OH 45236.

CONTACT INFORMATION

Steve Shanesy

Editor & Publisher

Specialties: Projects, techniques, article and project selection
513-531-2690 ext. 1238
steve.shanesy@fwpubs.com



David Thiel

Senior Editor

Specialties: Projects, new products and tools, tricks of the trade
513-531-2690 ext. 1255
david.thiel@fwpubs.com



Christopher Schwarz

Senior Editor

Specialties: Author liaison, web site, projects, hand-tool techniques
513-531-2690 ext. 1407
chris.schwarz@fwpubs.com



Kara Gebhart

Assistant Editor

Specialties: Special issues, author liaison, copy editing
513-531-2690 ext. 1348
kara.gebhart@fwpubs.com



Linda Watts

Art Director

Specialties: Magazine and cover design, photo direction
513-531-2690 ext. 1396
linda.watts@fwpubs.com



Our Privacy Promise to You

We make portions of our customer list available to carefully screened companies that offer products and services we believe you may enjoy. If you do not want to receive offers and/or information, please let us know by contacting us at:

List Manager, F & W Publications,
4700 E. Galbraith Road, Cincinnati, OH 45236

SAFETY NOTE

Safety is your responsibility. Manufacturers place safety devices on their equipment for a reason. In many photos you see in *Popular Woodworking*, these have been removed to provide clarity. In some cases we'll use an awkward body position so you can better see what's being demonstrated. Don't copy us. Think about each procedure you're going to perform beforehand. Safety First!



TWO GREAT BRANDS. ONE GREAT DEAL.

PROMOTION
EXTENDED
30 DAYS!

Now Ends
April 30, 2003



Buy the best-selling JET XACTA™ Saw and get a **BOSCH** Router FREE.

Priced at just \$1,699, the 10" XACTA™ Saw, with a powerful 3HP motor, and packaged with the XACTA™ Lift with a deluxe router fence, is a great deal. And now it's even better! Because if you buy this XACTA™ Saw package now, we'll upgrade your purchase to include our new Premier MicroAdjust Fence...that's a \$100 value!

But that's not all. You'll also get a Bosch Router...**absolutely free**. Valued at \$239, the Bosch 2 1/4 HP electronic, variable-speed router is the top choice. For more details, visit your local dealer, www.jettools.com, www.bosch.com or call 1-800-274-6848.

JET[®]
WMH TOOL GROUP

Offer valid October 1, 2002 through April 30, 2003.

Powermatic, Performax and JET. A Family of Brands.

CIRCLE NO. 130 ON FREE INFORMATION CARD.

The Toughest Glue On Planet Earth

You're beyond simple yellow glues and you don't want a different bottle of glue for every project. You want Gorilla Glue®. Bonds wood, stone, metal, ceramics and more. Incredibly strong and 100% waterproof.



for retailers near you:
www.gorillaglue.com
1-800-966-3458

LETTERS

Another Solution to a Planer Problem

Check for Chips in the Gap Under the Bearings for Your Feed Rollers

In the "Q & A" column in the February 2003 issue (#132), Tim Dewberry had problems with lumber not feeding through his portable thickness planer.

I had a similar problem with my planer recently. While I was planing $\frac{1}{8}$ " off of some pine, I noticed that the infeed roller was rising more than the outfeed roller. A large amount of moist chips had collected between the roller bearing block and its stop. The chips that collected in this gap prevented the spring from pushing the roller down against the lumber.

To fix the problem, I simply propped up one end of the infeed roller with a 5"-long block of wood and lowered the head just enough to keep the roller in place. I removed the roller's stop block and cleaned out the chips. To check to see if this is your problem, put a straight edge across both of your rollers and rotate the cutterhead so a blade is at its lowest point. The blade should clear the straight edge by about $\frac{1}{16}$ ". If it contacts the straight edge, then the roller is not dropping down on the stop.

Charles M. Winn
Deer Park, Washington

One Man's Solution for Making a Workbench Mobile: Pipe and Casters

I saw the letter from Michael Van Cleave regarding making a bench mobile, and your suggestion of using the Delta custom base. I think that it might not be sturdy enough for a heavy bench, especially when you consider pounding, sawing, etc. I have an old and simple bench made out of Douglas fir, and the way that I made it mobile was to make a frame using $1\frac{1}{2}$ " black pipe with pipe elbows at the corners. The frame was slightly larger than the base of the bench, then I set the bench in the base on some 2 x 4 cross members that I attached to the pipe using

the metal strapping used by plumbers to attach pipe to a wall. I mounted very large casters on each corner of the frame and away I went. This has worked out very well for me.

I picked up the casters at a garage sale, so I don't know too many details about them, but the person I bought them from said they were from Grainger's and were rated at 500 pounds each. They're quite large and have heavy-duty locks. To mount them I added pipe "Ts" to the frame and pointed the round opening down to the floor. The shaft slips right into it, and gravity holds it in place.

Kelly F. Hickel
St. Paul, Minnesota

Taking Issue With Tight-grained Pine and Oil Finishes on Cherry

In your February 2003 issue, Bob Flexner asserts in "The Challenge of Cherry" that "cherry, maple, birch and pine look too flat when finished with oil finishes." While I agree that pine (hardly a tight-grained wood) does not gain a gloss with an oil finish, the other species mentioned can easily be given a wonderful (even glossy) finish with linseed oil and proper technique.

I routinely finish the majority of my work with oil and wax. A recent project is a curly maple and purpleheart box that has such a high-gloss finish that everyone who has seen

WRITE TO US

Popular Woodworking welcomes letters from readers with questions or comments about the magazine or woodworking in general. We try to respond to all correspondence. Published letters may be edited for length or style. All letters become the property of *Popular Woodworking*.
How to send your letter:

- E-mail: popwood@fwpubs.com
- Fax: 513-891-7196
- Mail carrier:
Letters • *Popular Woodworking*
4700 E. Galbraith Road, Cincinnati, OH 45236

What's the Secret to Chip-Free Cuts in Melamine & Laminates?

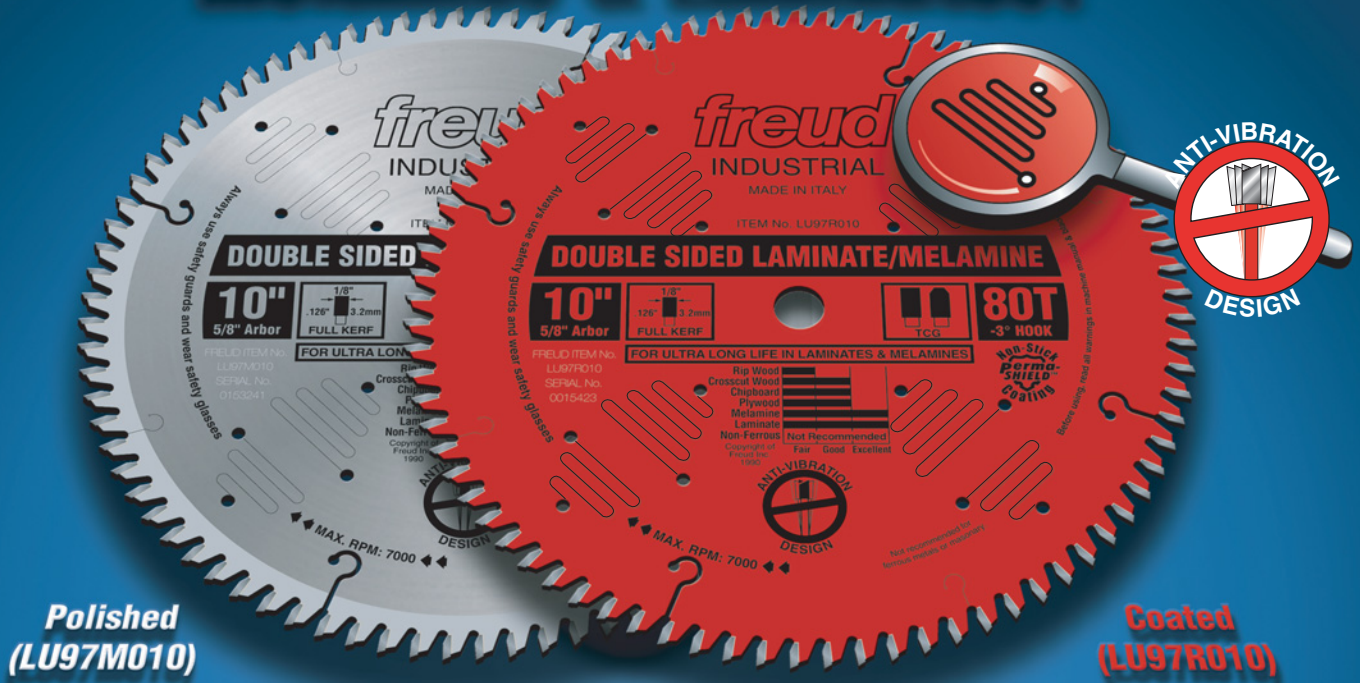

NEW Anti-Vibration Melamine & Laminate Saw Blades...by Freud



Anti-Vibration Design



Reduced Vibration & Chattering



No Additional Scoring Blade Needed

In the past, the best way to make clean, chip-free cuts in double sided laminate was to use an expensive panel saw with a separate scoring blade.

Not any more...

Freud's new **Anti-Vibration** Double-Sided Melamine & Laminate Saw Blades are designed to produce razor sharp, chip-free cuts in double-sided man-made materials.

Standard saw blades vibrate, causing chipping. Freud's unique Laser-Cut **Anti-Vibration** Slots virtually eliminate vibration and sideways movement of the cutting edge against the material. Now, in one easy slice, you can create flawless and chip-free cuts in man-made materials, on a standard table saw eliminating the need for a separate scoring Blade.

The 10" blades have 80 carbide teeth in a negative hook, triple chip grind (TCG) tooth design for long life and optimum performance. The specially formulated **Sub MicroGrain Carbide** is designed to withstand hard, abrasive man-made materials, prolonging the cutting life of your blade.

These blades are available either with Perm-SHIELD® coating (that prevents heat and pitch build up increasing the cutting life of a saw blade) or traditional polished finish.

Whether you're a production shop or a custom woodworker, Freud makes it easy for you to create endless chip-free cuts in abrasive, double-sided man-made materials.

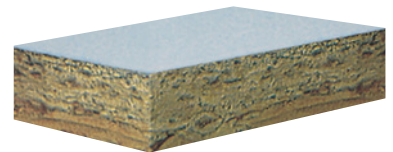

Melamine Cut with Freud Blade

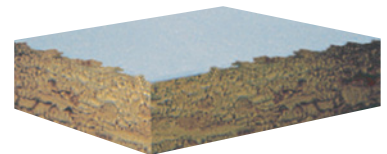

Melamine Cut with 'Other' Blade

freud®

The Psychology of Woodworking

ISO 9002
CERTIFICATE REGISTRATION # 12 100 9159

FOR MORE INFORMATION CALL 1-800-472-7307
IN CANADA CALL 1-800-263-7016
www.FreudTools.com

Red saw blades are a registered trademark of Freud TMM, Inc.

CIRCLE NO. 120 ON FREE INFORMATION CARD.

WOODLINE USA™ OFFERS YOU MORE... LIFETIME WARRANTY / GUARANTEED LOWEST PRICE

30

Piece PROFESSIONAL SET

All Woodline USA Products Feature
Tough Micro Grain Carbide

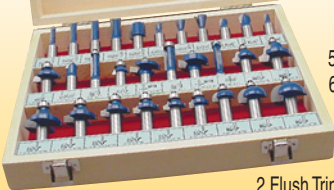

Includes:
5 Straight Bits
6 Roundovers
3 Dovetails
3 Core Box
3 Cove Bits

2 Flush Trim, 1 Panel Bit
2 Roman Ogee, 2 Slot Cutters, 1 "V" Groove
1 Chamfer and 1 Bevel Trim Bit

SUPER BUY

WL-2010 **OUR PRICE ONLY \$109** set



6 Piece CABINET DOOR SET

1/2" Shank Router Bits
• 2-pc Rail & Stile (Roman Ogee) • Drawer Lock
• 3 1/4" D Panel Raiser (Ogee) • Door Lip • Glue Joint

WL-2020-1 \$175 VALUE

OUR PRICE ONLY \$119 set

5 Piece CABINET DOOR SET

3/4" Bore Shaper
Cutter
• 1-pc Rail & Stile (Roman Ogee)
• 4 5/8" Panel Raiser (Ogee)
• Door Lip
• Glue Joint
• Drawer Lock

WL-1505 \$279 VALUE

OUR PRICE ONLY \$179 set

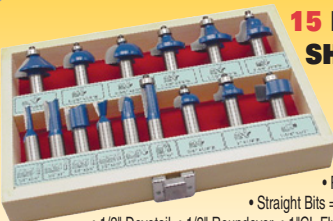

15 Piece 1/2" SHANK SET

Includes:
• Chamfer • Cove = 1/2"R, 3/8"R, 1/4"R
• Roundover = 1/2"R, 3/8"R, 1/4"R
• Roman Ogee = 1/4"R
• Straight Bits = 3/4"R, 1/2"R, 1/4"R
• 1/2" Dovetail • 1/2" Roundover • 1"CL Flush Trim • Rabbet Bit

WL-2022 for 1/2" or WL-2021 for 1/4" SHANK SET

OUR PRICE ONLY \$59 each set

5 Piece MOULDING SET



1/2" Shank Router Bits WL-2011 \$175 VALUE

OUR PRICE ONLY \$99 set

5 Piece DOVETAIL SET

• 14° 3/4" • 14° 5/8"
• 8° 1/2" • 14° 1/2"
• 14° 3/8"

1/2" Shank Router Bits

WL-2017

\$30 VALUE

OUR PRICE ONLY \$19 set

13 Piece DOVETAIL SET

1/2" Shank Router Bits
• 3 Straight Bits
• 10 Dovetail Bits

WL-2014

\$125 VALUE

OUR PRICE ONLY \$49 set

8 Piece PICTURE FRAME SET

Perfect for making great looking picture frames. Bits can be combined to form complex mouldings or simple decorative frames.

WL-2008 \$189 VALUE

OUR PRICE ONLY \$75 set



9 Piece MASTER DADO SET

Includes Undersize for Plywood, Standard for Hardwood and Oversize for Melamine or Veneered Materials. In 3 Popular Sizes: 1/4", 1/2" and 3/4".

WL-2030

\$89 VALUE

OUR PRICE ONLY \$39 set



3 Piece CABINET DOOR SET

1/2" Shank Router Bits • 2-pc Roman Ogee Rail & Stile
• 3 1/4" Panel Raiser

WL-2019-1 \$129 VALUE

OUR PRICE ONLY \$69 set

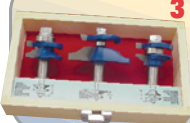

5 Piece COVE SET

1/4"R • 3/8"R • 1/2"R • 5/8"R • 3/4"R
WL-2015 \$99 VALUE

OUR PRICE ONLY \$49 set



1/2" Shank Router Bits

E-mail: woodline@woodbits.com

Visit us **WOODBITS**
at our Web site: **WOODBITS.COM**

GREAT ROUTER BITS AND SHAPER CUTTERS
BEST SELECTION / BEST PRICE!

ORDER TOLL FREE

1-800-472-6950

WOODLINE USA • P.O. BOX 298 • TEMECULA, CA 92593

• INDIVIDUAL BITS ALSO AVAILABLE • ALL MAJOR CREDIT CARDS
• PRIORITY SHIPPING: \$3.75 FOR UP TO \$99. / \$4.75 FOR \$100.+
• MOST ITEMS IN STOCK • SAME DAY SHIPPING

PREMIUM CARBIDE

• Tough Micro Grain Carbide
• Euro Anti-Kickback Design
• Super-Slick Non-Stick Finish
• Super Low Prices

ALL WOODLINE USA
SETS ARE PACKAGED IN
BEAUTIFUL WOOD BOXES

FREE CATALOG
See our great selection of
Bits and Cutters
1-800-472-6950

QUALITY Guaranteed

CIRCLE NO. 165 ON FREE INFORMATION CARD.

LETTERS

it believed it was finished with a polyurethane or varnish. This process is fast and simple and requires less time for the entire process than the drying time of most polyurethane finishes. By the way I never use stain on these projects; time does it best.

Perhaps if Mr. Flexner has the time he can stop by The Woodworkers Shop in Pekin, Ill., some Saturday and I can teach him how to handle these "challenging" woods.

Larry Kruzan
via the internet

I agree that pine isn't often classified as a tight-grained wood because it's a soft wood, and we're usually talking about hardwoods in woodworking. But if you think of oak, ash, mahogany and walnut as open-grained woods because they have a very distinctive grain (meaning pore depressions in the wood) it makes sense that pine would be the opposite because it also has no discernable pores in its surface.

Perhaps a better term is "closed-grained" or "closed-pored" – instead of "tight grained." Another problem is the definition itself. We woodworkers often refer to the color differences in pine as "grain," but aren't these differences closer to the color differences in cherry, which we refer to as "figure" than to the "grain" differences in oak? "Figure" would actually be the better word to describe what's going on in pine, though that term is rarely used.

Concerning the gloss you get, I would suspect that it is created by the wax you put on top of the oil-sealed surface. What does the oiled wood look like before you apply the wax? If it looked like you wanted it to, then I doubt you'd apply the wax. Of course what looks nice to each of us is purely subjective. PW

— Bob Flexner, contributing editor

CORRECTIONS

Popular Woodworking corrects all significant errors. For a list of corrections to the magazine (or to report one), visit our web site at: popwood.com/features/mag.html

In the "Built-in Basics" article in the February 2003 issue, the author recommended the McGrath Scribe and Profile Gauge. Since the article was published, this product has been discontinued and is no longer available.

In our review of 12-volt drills, we incorrectly stated the model number of the Panasonic drill. The correct number is EY6409GQKW.

Peg Your Tenons for Extra Authenticity

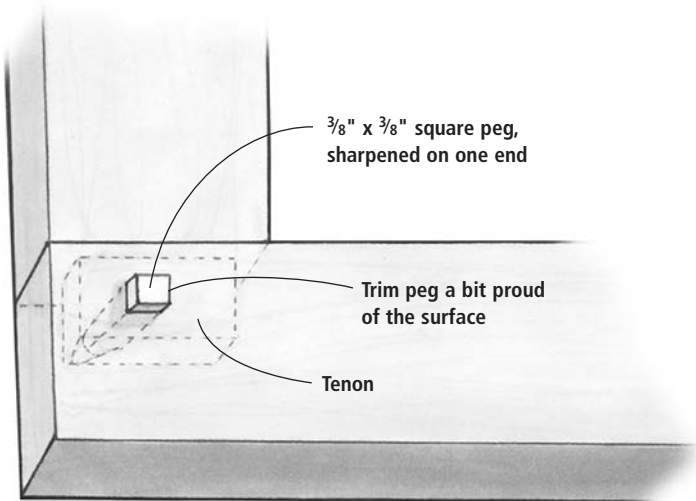

Illustration by Hayes Shaney

What is 'Square-peg Joinery'?

I am considering building a pair of American Corner Cabinets as described by Glen Huey in your December 2002 issue (#131).

I must admit my ignorance of "square-peg joinery," which Mr. Huey used to join the face frame and side supports to the shelves. I was unable to find any reference to this method of joinery in our public library and I've searched several woodworking books in our local book store without success.

Could Mr. Huey please provide some more information on this joint?

Bud Zinnecker
Lincoln, Nebraska

How Can I Prepare My Cast Iron Machines for Long-term Storage?

I purchased an 8" Grizzly jointer last year. I have enjoyed using the machine, and I want to protect my investment. Unfortunately, my shop is in an unheated garage, so I am unable to work much of the winter. I have prepared the cast-iron top to protect against rust, but I was wondering: Should I be concerned about rust on the knives as well? If so, would applying masking tape around the exposed edges of the knives help keep them protected? What do you suggest?

Patrick Ortlieb
via the internet

Square-peg construction is the addition of a square peg to any joint. The pegs were used in place of glues on antique pieces (today they are more decorative than functional). Here's how to make them: Take some $\frac{3}{8}$ " x $\frac{3}{8}$ " square stock and sharpen one end in a pencil sharpener. Drill a slightly undersized hole that goes through your joint but does not go through the other side (in the case of doors). Put a dab of glue in the hole and pound the peg in place. Cut the peg just a little proud and you're done.

— Glen Huey, contributing editor

Smart thinking to protect your jointer from wet weather. I'm not sure what you used to protect the tabletop on your jointer, but it's likely you can use a similar process to protect the knives and cutterhead from rust. We like using T-9 Rust Protectant from Boeshield. It sprays on and doesn't use silicone or Teflon, so it won't leave any residue that may affect any wood surface later. It dries quickly and will protect your metal surfaces for months. The benefit to the spray being you can shoot it onto the knives and cutterhead without getting close enough to

continued on page 16

WIN
a New 2003
Toyota Tundra
Pickup Truck &
a Shop Full of
Porter-Cable Tools
In The Woodcraft
75th Anniversary
Giveaway

WOODCRAFT™ 75th Anniversary Sweepstakes



TRUCK & TOOLS!

TOYOTA JET PORTER-CABLE

Enter
Online
at
www.woodcraft.com
for your chance to win

Void where prohibited by law,
complete rules
and regulations are
available online.

75th
SINCE 1928
anniversary

WOODCRAFT®

For your local woodcraft store,
visit www.woodcraft.com,
or for a free catalog
call 800 542-9115

Dept.03PW04BA

imagine how simple. how precise.

how is that possible?

The AKEDA DC-16V dovetail jig creates a new mark by which all other dovetail jigs will soon be measured.

With guide fingers that snap in place for fast, accurate and repeatable cutting, making through and half-blind dovetails with a router has never been so easy.

You'll find the AKEDA DC-16V dovetail jig exclusively at Woodcraft.

Whether you're a beginner or a master woodworker, experience the finest in woodworking tools, power tools, and education from our catalog, online at www.woodcraft.com, and at your local Woodcraft store.



WOODCRAFT[®]
Helping You Make Wood Work[®]

fine woodworking tools, accessories, expert advice

The Delta Edge

New from the company on the cutting edge of innovation.



Delta Industrial 12" TwinLaser™ Compound Miter Saw

Bright TwinLaser™ cut lines clearly indicate both sides of the blade kerf for faster and more accurate cuts. Plus a powerful 15 amp motor provides power for any job.



Delta Industrial 1/2 HP Mortiser

Featured with easy and open access to the drill chuck, adjustable fence and holddown, and a large cast-iron base with center through hole make this mortiser perfect for any shop.



Delta Industrial 14" Band Saw

Feature-packed with a powerful 1 HP, 120V motor, enclosed stand, 9-spoke wheels, 16"x16" tilting cast-iron table, and quick-release tension lever.

For complete product specifications on these and other Delta innovations visit your local dealer or deltamachinery.com.



Your achievement. Our tools.

CIRCLE NO. 114 ON FREE INFORMATION CARD.

Q & A

continued from page 14

nick yourself. You can get the spray from Woodcraft (woodcraft.com) or Jamestown Distributors (jamestowndistributors.com).

—David Thiel, senior editor

Which is Better: Direct-drive Table Saws or Belt-drive Table Saws?

I'm relatively new to woodworking. I'm considering upgrading my current contractor table saw next year, and I have a question about the pros and cons of direct-drive saws versus belt-drive table saws. Which would you recommend for someone who is serious about improving their skills?

Greg Long
Corvallis, Oregon

The pros and cons are simple. Direct-drive saws use universal motors (with the exception of some industrial equipment), similar to the motors used in routers. They spin up to a high rpm, but provide limited torque for larger applications, such as ripping a board on a table saw. They also are noisier and have a shorter life span.

While a universal motor is adequate for trim work and many small weekend projects, the power, torque and reliability from a belt-driven induction-motor table saw is the better choice for building furniture.

—David Thiel, senior editor

What is the Best Strategy for Finishing Quilted Maple: Dyes or Oils?

I would just like some advice on the best way to finish quilted maple. I would like to bring out the figure while not having to color the wood too much. Does an oil finish bring out the figure as well as dye?

Mike Berkshire
via the internet

You have two choices: Apply boiled linseed oil as a first coat or use an aniline dye. Boiled linseed oil has an orange coloring that adds a little color (not much), but this color darkens as the oil ages. This is a good way to go if you have time to wait. You might try some on some scrap and see if you get enough coloring to satisfy you. Be sure and wipe off all the excess oil and hang your rags up to dry so they don't spontaneously combust.

You can apply any finish over the oil once it has fully cured. Give it about a week in a warm room before you add another topcoat.

Dye is the more effective way to get instant

results. Water-soluble dye is the easiest to use. Choose whatever color you want and thin it until you get just enough coloring to make you happy. You can apply any finish you'd like over the dye once it has dried, but water-based finish will re-dissolve the dye and cause it to be smeared. It also will work against your desire for a warm effect. You can use boiled linseed oil as described above, or any film-building finish such as varnish, shellac or lacquer over the dye. Amber shellac will also add some warm coloring but won't make the wood pop like dye will.

—Bob Flexner, contributing editor

Can I Glue a Project Together After Staining?

I have problems with glue squeeze-out, which prevents some parts of my project from getting stained. I seem to remember that one solution is to stain prior to glue-up. I've gone back in my magazines but couldn't find anything about that procedure. I did find information about cleanup and using masking tape to help eliminate the problem. However, is staining prior to glue-up a feasible alternative? And if so, do you stain the area to be glued or keep it a "clean" area?

Dick Hicks
via the internet

Most glues are a water-based product, so they can smear water-based dyes and have problems bonding parts soaked with oil-based stains (that whole water and oil not mixing thing is a real problem). Your better bet is to mask off all the joints and fill any mortises with packing peanuts. Then stain and add your topcoat finish. Remove the tape and then glue up your project. PW

—Christopher Schwarz, senior editor

WRITE TO US

Every day we get questions from readers on all subjects about their woodworking. Some are letters; many are e-mail messages. We are more than happy to share our woodworking experience with you by answering your questions or adding some clarity to whatever aspect of your craft you are unsure about. In addition to the hundreds we answer privately every month, we want to share the best questions here with readers.

Send your questions via e-mail to popwood@fwpubs.com. Or send us a note by mail to: Popular Woodworking, Q&A, 4700 E. Galbraith Road, Cincinnati, OH 45236.



Wow. He must really love you.

Custom cabinets don't come cheap.

Your woodwork gets undivided attention. Inspired creations usually do. And Delta is proud to help by making the best tools for the job. Any job. So get a tool known for innovative design and reliability. Get a Delta. For a full-line catalog call 800-438-2486 (US), 800-463-3582 (Canada), or visit deltamachinery.com.



 **DELTA**[®]
Your achievement. Our tools.

CIRCLE NO. 114 ON FREE INFORMATION CARD.

Finest Quality Reproduction BRASS & IRON HARDWARE

Since 1933, Ball and Ball has been manufacturing the highest quality reproduction furniture hardware, builders hardware, lighting fixtures, and fireplace accessories available.

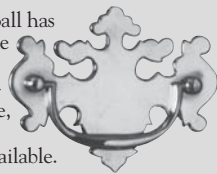

Call for our 108-page catalog available for \$7.00.
(catalog cost refunded on first order)

463 W. Lincoln Highway (Rt. 30)
Exton, PA 19341
610-363-7330 • Fax: 610-363-7639

1-800-257-3711

www.ballandball-us.com



CIRCLE NO. 104 ON FREE INFORMATION CARD.

QUARTERSAWN HARDWOODS & HIGHLY FIGURED LUMBER

Ash, Cherry, Hard Maple, Red Oak,
White Oak, Walnut, Sycamore,
Mahogany, Hickory, and Birch.
Also, many *Exotic Species* in Stock.

NEW We now have
Curly Bubinga, Curly Makore
& other figured exotics

WEST PENN HARDWOODS, INC.
(888) 636-WOOD (9663)
www.westpennhardwoods.com

The Keller Dovetail System:

“Your best choice”

- *Woodworker's Journal*

“The setup is easy, adjustments minimal and the joints perfect. It's the easiest of all the jigs to use and great for production use.”

- *Woodworker's Journal*

“In a class by itself.”

- *WOOD Magazine*

VIDEO: \$8.95 + \$2 P/H

No test cuts. Fast setup. Unlimited widths. Precision joinery. Classic and variable spacing. Compound angles. Curved dovetails. Box joints. 20 year warranty. Made in USA since 1976.

To find out more, contact your Dealer or



KELLER & CO.

1327 'I' Street, Dept. P33

Petaluma, CA 94952

1-800-995-2456

707-763-9336

www.kellerdovetail.com

Keller Dovetail System

Simply the best!

CIRCLE NO. 132 ON FREE INFORMATION CARD.

TRICKS OF THE TRADE

Stop Your Scraper From Scorching You

THE WINNER:

I didn't think that a cabinet scraper could get hot enough to burn until it happened to me – twice. I made this simple holder to prevent future blistered thumbs.

Make the main piece of the holder from any available 1/2"-thick scrap of hardwood. Cut this piece about 1" longer and 1/2" narrower than your scraper. Cut both clamp strips from a longer piece of scrap by using a table saw to make a 1/16" x 3/8" rabbet along one edge, then rip off a 5/16"-wide strip (the rabbet should be a hair wider than the thickness of the scraper). Attach the clamp pieces to the holder with screws. The thumbscrew will cut its own threads if screwed into an undersized hole.

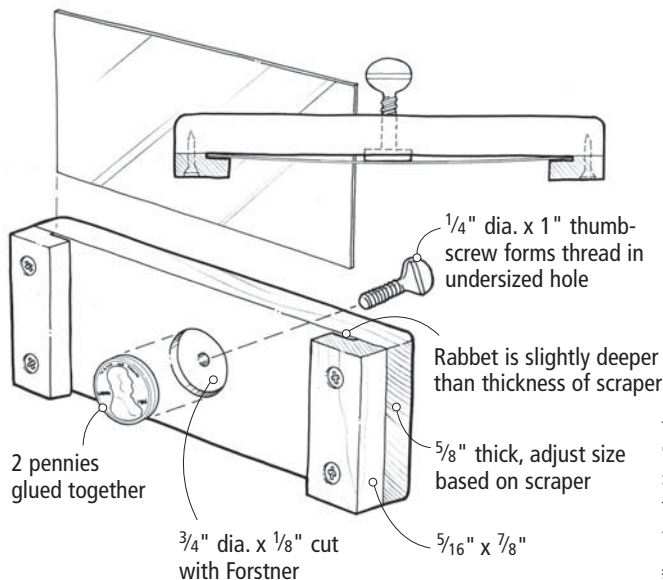

Illustrations by Matt Bantny

In use, the thumbscrew presses against a penny, which flexes the blade. Because this jig doesn't have a top and bottom, simply flip it over to use a fresh burr on the opposite edge.

Joe Hurst-Wajszczuk
Denver, Colorado

continued on page 20

CASH AND PRIZES FOR YOUR TRICKS AND TIPS!

Each issue we publish woodworking tips and tricks from our readers that we think are useful. We want to encourage you to share with your fellow woodworkers, as well as reward the most useful and original concepts. The winner this issue and the June issue will receive a fantastic finish-sanding kit from Fein Tools, including the Turbo III vacuum and a MSF 636-1, 6" right-angle sander – \$1,000 worth of tools! This package is, in our opinion, the best finish-sanding setup you can buy. But our winner won't have to.

Send us your tip or trick by e-mail (along with a daytime phone number) to david.thiel@fwpubs.com or mail it to:

Tricks of the Trade
Popular Woodworking
4700 E. Galbraith Road
Cincinnati, OH 45236



BIG VALUE

For Just A Few Bucks, You Get A Whole Lot Of Bits.



Router Bits



Drill Bits



Shop Safety Set



Forstner Bits

Other sets available.

For just a few bucks, you can get all the bits you need for your next project – and more!

Hickory Woodworking sets provide tremendous value with a whole lot of bits to help you produce a wide variety of project designs. For more information, call **1-800-828-9000** or visit www.oldham-usa.com.



Be a woodworker!

TRICKS OF THE TRADE

continued from page 18

A New Angle on PVC Storage

I came across this simple storage solution and thought I would pass it along. It uses 4" PVC posts and a simple jig on your miter saw. This assembly can be built in about an hour. Once you've determined the angle you want your tube opening (I used 40°) set your miter saw to half that angle (20°), angling the blade to the right. Make one cut on a piece of scrap 4x4 material. Now swing your blade to the left, again set at 20°, and slide your PVC post in place and make a cut on one end. Adjust your piece of scrap 4x4 to the proper distance from the blade and clamp it in place. Now slide the pipe against the scrap so the two 20° angles mate. Make your cut, turn the tube and cut the next piece you need.

Create different-height storage bins by simply adjusting the stop block's location. In my example, each row of bins is 1½" longer than the one above. The bins are held against a ¾" piece of plywood with

just one screw on the bottom center of each bin. This, plus an aluminum strap around the bottom, holds everything secure.

Stacy G. Nettinga
Mitchell, South Dakota
continued on page 22

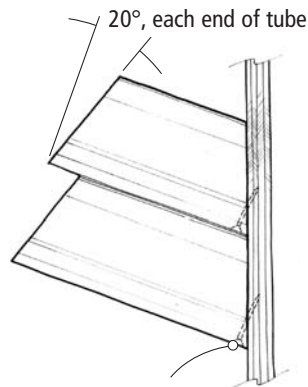

One screw at the bottom of each tube attaches it to the plywood base

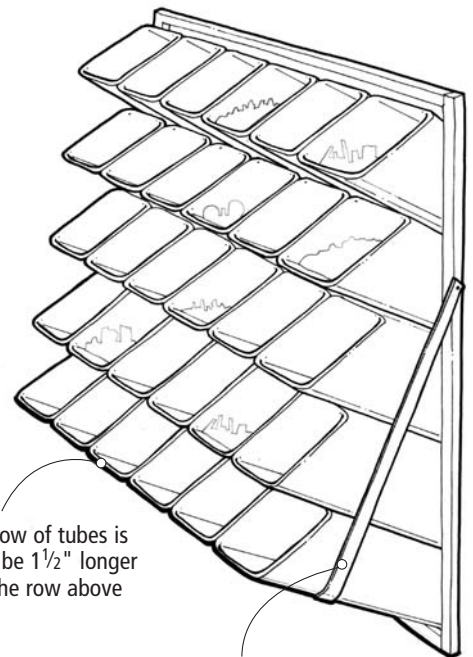

Metal strap keeps unit together



THE LEADER IN DIAMOND SHARPENING
Diamond Machining Technology, Inc.
www.dmtsharp.com
800.666.4DMT

“To protect my investment in quality tools, I rely on the quality performance of DMT® Diamond Machining Technology Sharpeners – all American made. DMT maintains the precision cutting edges of my chisels, planes, and knives.”

The first rule of shop maintenance is
Sharpen your tools



6" Diamond Whetstone™



DuoSharp®

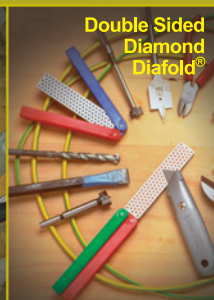

Double Sided Diamond Diafold®

SCOTT
PHILLIPS
SIGNATURE
SERIES

Master Woodworker,
Educator and Host of
American Woodshop

CIRCLE NO. 116 ON FREE INFORMATION CARD.



Hand Tools for Serious Woodworkers

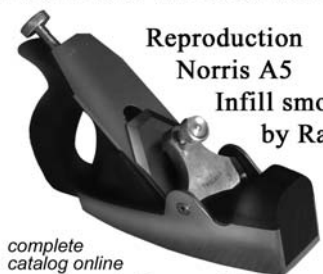

Reproduction
Norris A5
Infill smoother
by Ray Isles.
\$599.95

complete
catalog online

www.toolsforworkingwood.com
27 W 20 St. #507, New York City
Call 800-426-4613

CIRCLE NO. 155 ON FREE INFORMATION CARD.

PORTABLE SAWMILLS



Handheld portable band mill goes to the log where it lays. Mill weighs 45 lbs., cuts logs up to 20" dia., cuts up to 12 fpm, 9 x 14" throat, .025" narrow kerf blade. Larger mills available. Contact us today!

www.ripsaw.com

Better Built Corp.
789 Woburn St. Dept PW
Wilmington, MA 01887
978-657-5636

CIRCLE NO. 107 ON FREE INFORMATION CARD.



Hickory Woodworking
Fine Woodworking Accessories

7pc & 16 pc Forstner Bit Sets



1250 7 pc set Reg \$24.95
\$16.95



1/4" to 2-1/8" by 1/8" increments
1252 16 pc set
Regular \$59.95 **\$39.95**

25 pc Brad Point Drill Bit Set



1/16" to 1/2" 1302 - Retail \$29.95
SALE \$19.95

7 pc Tapered Drill Set



1316 For screw sizes 5, 6, 7, 8, 9, 10 & 12
Retail \$29.95 **SALE \$19.95**

Mirka Sandpaper



9" x 11" Carat Brand White Finishing Sheets 50 pack
Buy 4 or more packages
Save extra \$1.00 OFF per pkg
MIX-N-MATCH Grits

Made in Finland
Regular \$21.95 pkg
\$17.95 pkg
Your Choice Grit

Mirka Bull Dog Gold

D-Weight - Hook-n-Loop
5" X 5 hole or 5" X 8 hole - 50 box



5" x 5 hole
1009 - 80g
0981 - 100g
0982 - 120g
0983 - 150g
0984 - 180g
0985 - 220g
0986 - 320g
0987 - 400g
0988 - Asst

Buy 4 or more boxes
Save extra \$1.00 OFF per box.
MIX-N-MATCH Grits

Regular \$19.95 box
\$14.95 box
Your Choice Grit
Made in Finland

5" x 8 hole
0989 - 80g
0990 - 100g
1020 - 120g
1021 - 150g
1022 - 180g
1023 - 220g
1024 - 320g
1025 - 400g
1026 - Asst

Clamp-n-Tool Guides

4900 CT-24" \$25.95
4901 CT-36" \$28.95
4902 CT-50" \$33.95



Back-to-Back Clamps

4903 BB-18" \$34.95
4904 BB-36" \$41.95
4905 BB-50" \$51.95

Works Great as a Fast Attaching Fence for Band Saw or Drill Press Tables



with 30 Day Money Back Guarantee

30 pc Shop Carbide Tipped Router Bit Sets



Only \$3.33 each!

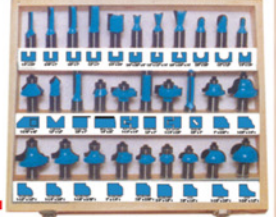

4754 - 1/2" shk Your Choice **\$99.95**
4755 - 1/4" shk Reg \$159.95

24 pc Carbide Tipped Router Bit Sets

4752 - 1/2" shank
4753 - 1/4" shank
Reg \$129.95

Your Choice **\$79.95**
Only \$3.33 each!

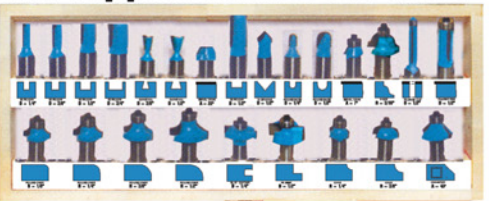

15 pc Carbide Tipped Router Bit Sets

4750 - 1/2" shank
4751 - 1/4" shank
Reg \$67.95

Your Choice **\$44.95**

"That's only \$3.00 per bit"

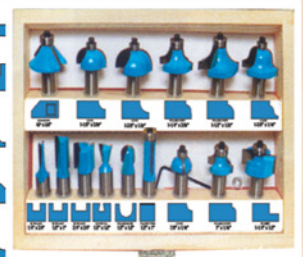
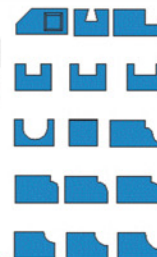

Order Now 1-800-892-4866

Visit The WoodShop On-Line Catalog Store to find a giant selection of woodworking tools & accessories, PLUS fantastic deals on Overstock & Discontinued Items

www.thewoodworkerschoice.com
www.1-800-twc-4tools.com

The Woodworker's Choice

2 The Professional Drive
West Jefferson, NC 28694

Ad Special - \$3.95 shipping within continental USA

Individual & Package Deal Tru-Grip Clamps

Individual Pro ft'r Accessories

4911 4' PRO ft'r \$66.95
4913 Router Base \$26.95
4914 Saw Base \$28.95

Tru-Grip Pro ft'r Package

Includes:
(1) 4911
(1) 4913
(1) 4914
\$119.95

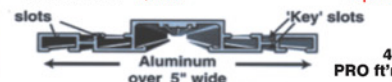

4900A Woodworker's Super Package
Includes: (2) 4904, (1) 4902
\$109.95

Because Woodworkers Like To Buy From Woodworkers



Top Quality Square Drive Screws



- McFeely's In-House QC Department Inspects each Production Run
- Our High Standards Ensure You of High Strength Screws
- Over 900 Varieties in Stock!

Write for FREE Catalog!

McFEELY'S
SQUARE DRIVE SCREWS

PO Box 11169 • Dept PWWDD • Lynchburg • VA • 24506
Toll Free 1-800-443-7937 or at www.mcfeelys.com

CIRCLE NO. 137 ON FREE INFORMATION CARD.

TRICKS OF THE TRADE

continued from page 20

Hold Tapered Legs in a Straight Vise

I recently made a small table with tapered legs. Holding these legs to work on in a standard bench vise entails making a set of wedges that can be awkward to maneuver, so I quickly knocked together this holding jig from scraps.

The jig required a base of $\frac{1}{2}$ " plywood, approximately 18" x 6". It has a central kerf, about $\frac{1}{8}$ " wide, that stops 2" from the end. Next, I added two battens 18" x 1" square, screwed to the base and spaced to match the leg taper. With the leg positioned in the jig and the jig clamped into my vise, as the vise is closed on the jig the kerf will close, forming a firm grip.

Peter Giolitto
Surrey, England

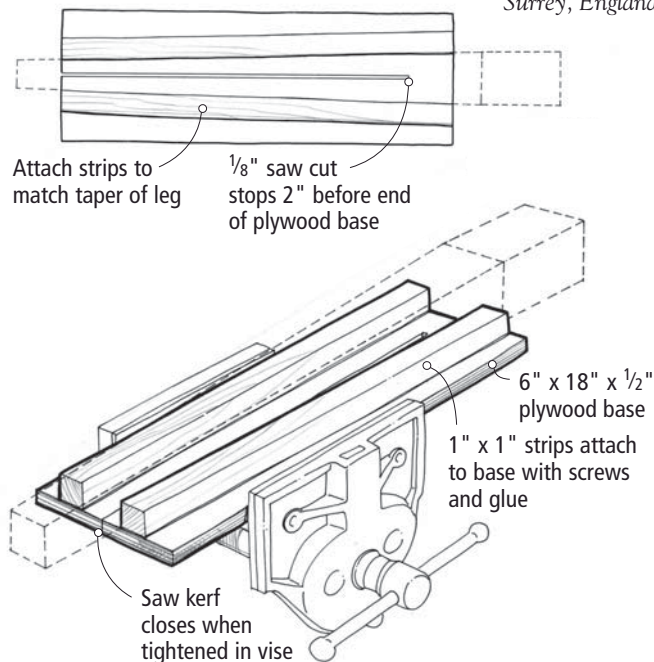

Fingernail Buffing Stick Fixes Finishes

I recently overheard my wife telling one of her friends about a fingernail buffing stick she just got. This 6" stick (about \$1 at the drug store) has three "grits" in graduated degrees of abrasiveness. The final step is like an emery board and is about 220 grit. I found a great use for this buffing stick on finishes that have minor defects.

A recent project I was working on had a run in the finish. I carefully scraped the run off, but I needed to blend in the remaining defect with the surrounding finish. Using this buffing stick and working through the different grits, I completely removed the raised area and blended the surface with the surrounding finish.

I also have a formal dining table that had some super glue on it (thanks kids). Again, after careful paring off the excess glue I then used the buffing stick to gently buff out the defect. You'd never know anything had been there!

Joe DeVoe
Menomonee Falls, Wisconsin

continued on page 24

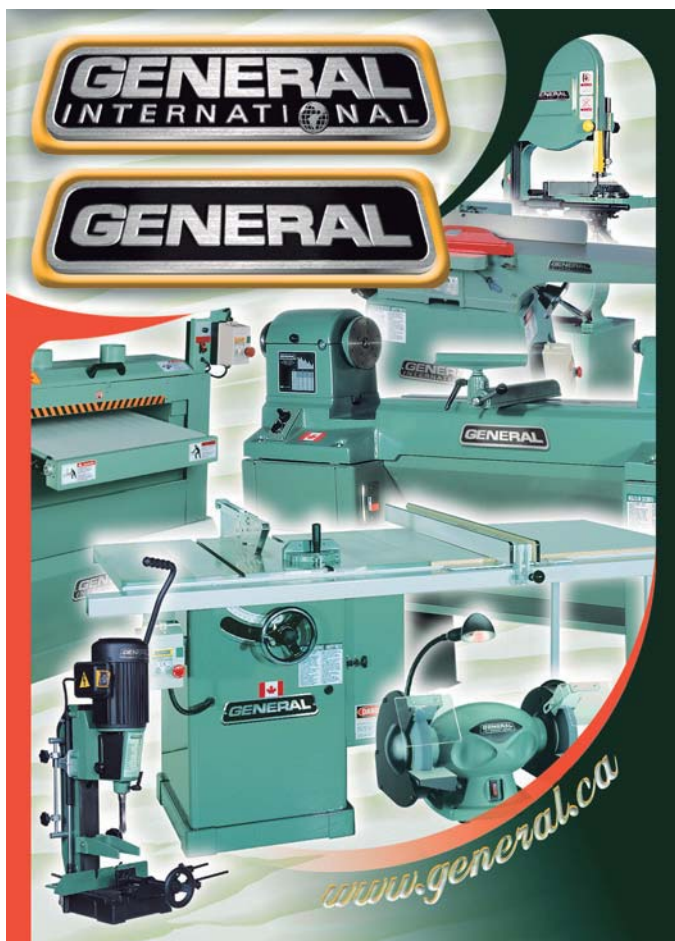

CIRCLE NO. 121 ON FREE INFORMATION CARD.

WE MADE A DISCOVERY. People Drop Things.



46 feet

Amazing. But True.

Plates of food, overfilled grocery bags, footballs at crucial moments, and power tools at work. We kept that in mind while designing our new line of cordless power tools. The collar of our Brute Tough™ drill is reinforced with steel. Its Body Armor™ is so durable, you could drop it forty-six feet. Not that you would. But we did. And despite taking a mean bounce off unforgiving concrete, it came up working. We dropped it again. Another forty-six feet, put in the drill bit, and bore a good two inches into concrete as payback. Downtime? Not hardly.



See it at boschtools.com

Attorney Alert: Do not try this test at home. Or at work.

CIRCLE NO. 108 ON FREE INFORMATION CARD.

© Robert Bosch Tool Corporation 2003

Rockler.com
WOODWORKING SUPERSTORE

WIN A DELTA[®] UNISAW



Register online at...
www.rockler.com/delta

No purchase necessary. See official rules at www.rockler.com/delta.
Void where prohibited by law. Entries must be received by April 30, 2003.

CIRCLE NO. 149 ON FREE INFORMATION CARD.

ROUTER & TABLE SAW SYSTEMS

- **Combination Router & Table Saw Fences**
Micro Adjustable, Accurate to 1/1000 of an inch
- **Router Tables, Table Saw Extension and Floating Infeed/Outfeed Tables**
Available in Solid Phenolic or Melamine
- **Complete Table Saw Upgrade Systems**
Available for virtually all Cabinet & Contractor Saws
- **True Zero Clearance Miter/Cutoff Sled**
Micro-Adjustable, Positive Detents Every 1/2 Degree
- **Table Mounted Router Lift System**
Raise & Lower a Router with 1/1000 of an inch precision
- **And Much More...**

Router Table
Systems Available



Jointech Routing Center

BEST
NEW
TOOL
POPULAR
WOODWORKING

SMART MITER[™]
Voted Best New Tool by
Popular Woodworking!

FREE CATALOG!

CALL TODAY! 1-800-619-1288

www.jointech.com

JOINTECH
ULTRA-PRECISION WOODWORKING SYSTEMS

Jointech, Inc. is an official
dealer for products made by
**GENERAL
INTERNATIONAL**

CIRCLE NO. 131 ON FREE INFORMATION CARD.

TRICKS OF THE TRADE

continued from page 22

Pipe Cleaners for Gluing

Several times a year I use my biscuit joiner to join boards. After cutting the slots, I put glue on the edge of the wood and in the slots. Then, to make sure the glue covers the entire area of the slot, not just the bottom, I use a pipe cleaner to smear the glue. This is a quick, clean and inexpensive way to make sure you get a good bond with the biscuit. The pipe cleaner can also be used to smear the glue on the edge of the board and on the biscuit before joining. By twisting the cleaner to form an oval, you get even coverage within the slot. Then simply throw the used pipe cleaner away.

Even though I own a glue bottle for biscuit slots, the pipe cleaners are quicker and don't require clean up.

John Erwins
via internet

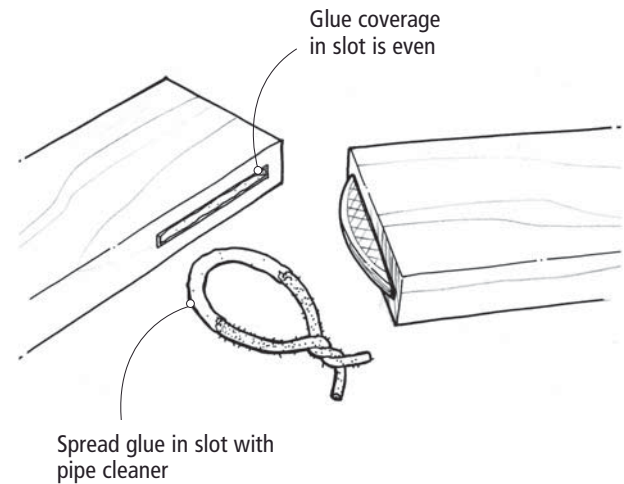

Stud Finders Not Just For Walls Anymore

While building a large cabinet for my family room recently, I stumbled on a good way to locate cabinet shelves and partitions without having to measure. I was attaching the plywood back to the cabinet sides with screws and realized the back span was pretty wide, so I thought it prudent to also screw the back to the shelves and the vertical dividers of this frameless cabinet.

I hate to measure when I don't have to. So I took my inexpensive stud finder and waved it over the back to find out where the dividers were located. Since the stud finder reacts to density, rather than locating metal, it pointed out where each divider and shelf began and ended. The little gizmo proved quite accurate, and I marked the shelf and partition locations and then pilot drilled my holes for my #6 screws. It worked perfectly. This technique also is handy for screwing $\frac{3}{4}$ " sides to the shelves – if your stud finder is designed to scan deeply into walls.

Christopher Schwarz
Popular Woodworking Staff

continued on page 26

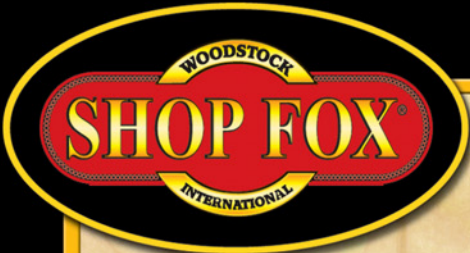

FASTEST GROWING MACHINERY LINE IN THE U.S.A.

INNOVATIVE PRODUCTS

DESIGNED FOR PRACTICAL USE

10" LEFT TILT TABLE SAW

W1677

THE HOTTEST SELLING
CABINET SAW
ON THE MARKET!

IN STOCK NOW



10" LEFT TILT TABLE SAW

This saw will definitely take center stage in any shop! Our saws with extension kits, shown on the right, will allow you to cut wide sheet stock all day long without missing a beat! Loaded with features:

- Powerful 3 HP motor with triple belt drive
- 2 Large cast iron wings
- Jumbo miter gauge with patented adjustment feature
- Precision ground cast iron table
- Shop Fox® Classic Fence with 26" rip capacity



SHOP FOX® is a registered trademark of Woodstock International, Inc.

CALL FOR THE LOCATION OF A DEALER NEAR YOU!

1-800-840-8420

VISIT OUR WEBSITE FOR MORE SHOP FOX® PRODUCTS

SHOPFOX.BIZ

sales@woodstockinternational.com

CIRCLE NO. 167 ON FREE INFORMATION CARD.

ASK ANY FINE WOODWORKER AND HE WILL TELL YOU THIS:

**QUALITY MACHINES
PRODUCE QUALITY RESULTS.**

THAT IS WHY WE DESIGN OUR MACHINES TO THE MOST STRINGENT STANDARDS, TRIPLE CHECK EACH ONE FOR QUALITY ASSURANCE AND BACK EVERY MACHINE WITH A FULL TWO-YEAR WARRANTY!

SEE OUR EVER EXPANDING LINE OF MACHINERY AT A QUALITY DEALER NEAR YOU.

10" LEFT TILT TABLE SAW WITH EXTENSION KITS



W1677EXT1

- Equipped with Shop Fox® Classic Fence
- 7' Long rails (Provides a 52" wide ripping capacity)
- Support legs
- Super durable laminate extension table

AVAILABLE
JANUARY
2003



W1677EXT2

- 7' Long rails
 - Support legs
 - Super durable laminate extension table
- Features Original Shop Fox® Heavy-Duty Fence
(One of the best fences on the market!)

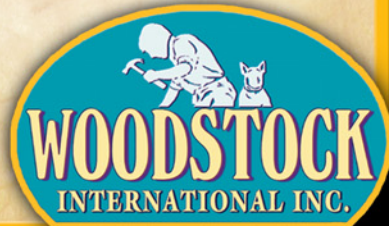

TRICKS OF THE TRADE

continued from page 24

Make a Rabbet Block Plane

I recently converted a common #220 Stanley block plane into an effective rabbet plane. I think a block plane's comfort, low profile and blade angle can provide precision for paring tenons, rabbets and bevels of raised panels (and it is significantly cheaper than the typical rabbet plane).

To begin, drill a $\frac{5}{16}$ " hole through the side of the plane. Next, carefully hacksaw an intersection from the plane throat to the hole (making sure the lower cut is shy of the final line). File until the blade seats flush on the new section of plane bed. To accommodate the lateral shift in the blade, use a metal grinding wheel to make a recess on the side of the blade. Then file a wider blade slot and one adjustment groove slightly longer. Next, to improve shaving removal, file a smooth ramp on the corner of the lever cap. Lastly, turn a larger knob for better two-handed control. With all the money you save, you can buy another #220 and modify the other side. **PW**

*Stephen Campbell
Westhampton, Massachusetts*

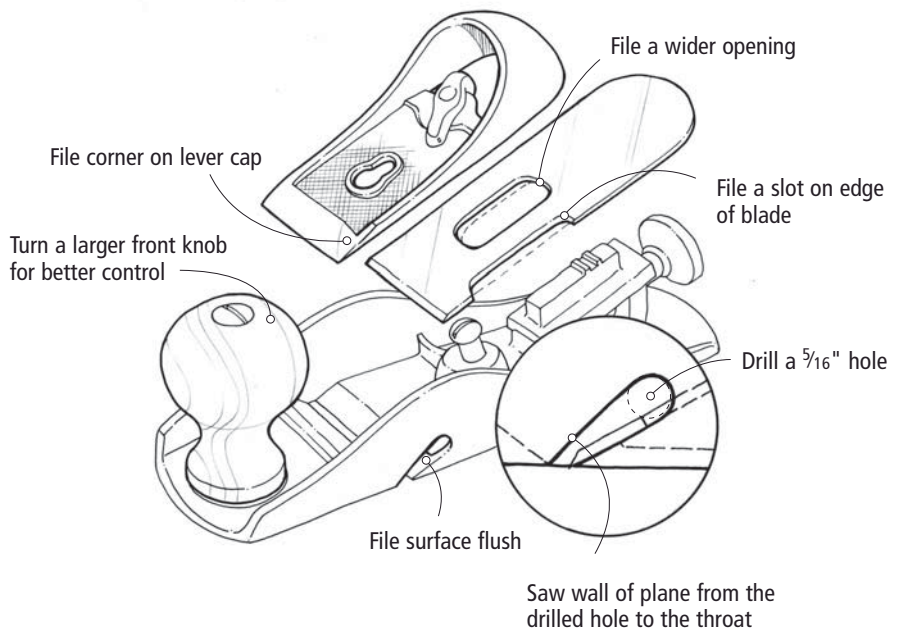

The Easy Rout.



The Leigh Dovetail Jig has it all. Hobbyist or professional, the Leigh D4 Dovetail Jig will ensure you create your best work. Versatility, precision and superb value make the Leigh Dovetail Jig better than the rest. Rout through and half-blind dovetails up to 24" wide in boards up to 1 1/2" thick, with infinitely variable spacing of pins and tails — all on one jig. Plus, rout sliding and angled dovetails easily with the D4. And create decorative Isoloc joints, finger joints, and multiple mortise & tenons effortlessly with Leigh attachments and our exceptional user guides! Make routing easier with Leigh. Call toll free now!

Call For Your FREE Leigh Catalog Today! 1-800-663-8932

LEIGH
Joining Tradition With Today

Leigh Industries Ltd., PO Box 357
Port Coquitlam, BC Canada V3C 4K6
Toll free 1-800-663-8932 Tel. 604 464-2700
Fax 604 464-7404 Web www.leighjigs.com

The all-in-one tool at a new low price

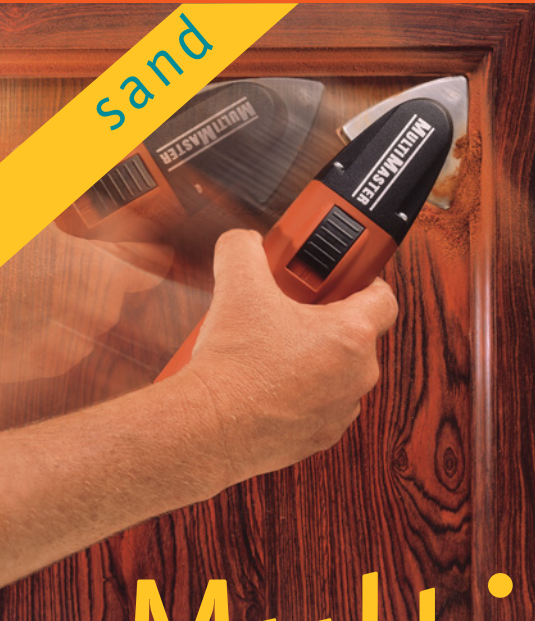

MultiMasterStart

New single-speed version. Just turn it on and go!

- Detail Sander •Power Scrape •Oscillating Saw

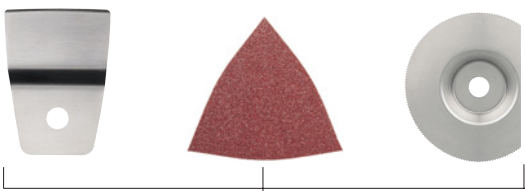

Accessories included

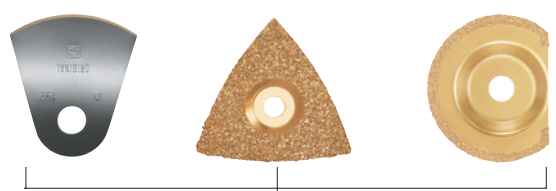

Optional Professional Kit

Go where other sanders can't. Sand into tight corners, along window panes, between shutter slats.

Saw where others fear to go. Cut putty along windows and into corners, undercut door jambs. The segmented blade lets you saw right up to the adjoining surface.



The MultiMaster blade oscillates to prevent kickback, vibration or accidents.

**Finishing
is just the
beginning**

Scrape cleanly and smoothly. Glide through paint, wallpaper, caulking and linoleum. The MultiMaster does all the work!

Just turn it on and go. All you do is steer! And best of all, you won't break the bank. Call **1-800-441-9878** for more details and our free brochure, or visit us at www.feinus.com.



Fein

Fein Power Tools, Inc.
1030 Alcon Street
Pittsburgh, PA 15220

CIRCLE NO. 118 ON FREE INFORMATION CARD.

Clifton Bench Planes

These premium British handplanes hit our shores in 2001 with much fanfare. Find out how they've held up on the job.

Most woodworkers who have shopped for a premium handplane have undoubtedly considered buying an English-made Clifton plane but wondered how they compare to the U.S.-made Lie-Nielsens.

It's a reasonable question. Both brands are based on the venerated Bed Rock line of Stanley planes that have been out of production since the mid-20th century. But the Clifton planes are \$30 to \$80 less expensive, depending on the size of the plane.

As far as bottom-line performance goes, these planes can be tuned to a high level, much like a Lie-Nielsen, some vintage Stanleys, Veritas planes, infills and choice wooden planes. In my opinion, the final performance of any plane depends a lot on the user.

So here's a close look at how the Cliftons arrived from the factory and what it took for me to get them cutting perfectly.

The Cliftons are made from grey iron with brass fittings and bubinga handles. The heart of the tool is where the iron, frog and plane body meet. How well all three of these things fit together is the most important factor in determining how well the plane will slice wood without chattering.

The four different Cliftons I've used were machined very well at the frog, with an excellent fit between the frog, iron and body. I especially like the Clifton iron and its unique two-piece chipbreaker. With this heavy-duty chipbreaker you can easily pop its front edge off to sharpen the iron without removing the entire chipbreaker. This speeds sharpening and is a nice convenience.

My one complaint has been with the blade adjustment mechanism on the #4 I've tested. The yoke, which controls the blade's projection from the sole, and cap iron were a little off. As a result, the iron needed to be retracted almost all the way back for smoothing. The chipbreaker was cheerfully replaced

by the distributor. The other three planes were perfect on this point.

The soles of the planes I've examined have varied from the dead-flat sole of the #3 smoothing plane to the slightly less than perfect #5 jack plane. The sole had gaps of .005" in places, according to my feeler gauge. None of the planes has been unacceptable in sole flatness, and all could be trued in far less time than it takes to flatten the sole of a typical vintage flea-market special.

Besides truing the soles, the one other modification I've had to make to the Cliftons is grinding off a bit of the rod that holds the tote. It looks like the bubinga handles on two of the planes have shrunk a bit and they wobbled a bit during use.

All of these have been minor inconveniences. The planes do perform beautifully when tuned. In fact, the #3 smoothing plane performs exceptionally well.

To get to this point, the Cliftons needed a lot less work than a vintage Stanley plane and hours and hours less work than the new Stanley and Record planes I've encountered. On average, you can expect an hour or two of tuning your new Clifton. The Lie-Nielsen planes I've tuned have required less work and also use different materials (unbreakable ductile iron bodies, rust-proof bronze frog castings and cryogenically treated A2 irons). These refinements are likely the difference in price between the two brands.

So is the Clifton a worthwhile plane? I think so. If you want to save a little money, are willing to put a bit more work into fettling the tool and aren't bothered by the differences in materials, then the Cliftons are



SPECIFICATIONS

Clifton Bench Planes

Street price:

- #3 smoothing plane: \$220
- #4 smoothing plane: \$220
- #5 jack plane: \$220
- #6 fore plane: \$300
- #7 jointer plane: \$350

Iron thickness: 1/8"

Blade material: O1 steel

Nice features: Excellent planes for the serious woodworker. Iron, frog and plane body are well bedded.

Recommended modifications: Some have needed more fettling than others, though much less than a Record or Stanley.

For more information: Contact Robert Larson at 800-356-2195, or rlarson.com. Or the Museum of Woodworking Tools (toolsforworkingwood.com or 800-426-4613).

ABOUT OUR ENDURANCE TESTS Every tool featured in our Endurance Test column has survived at least two years of heavy use in our shop here at *Popular Woodworking*.

a good choice for you. However I recommend you get your hands on both brands at a woodworking show and make some serious shavings before you make the call. **PW**

— Christopher Schwarz

If you are in a woodworking business... this could be the most valuable tool in your officesm.

Please call 1-800-645-9292 for your 484 page catalog.

FREE to woodworking businesses.

visit us at woodworker.com

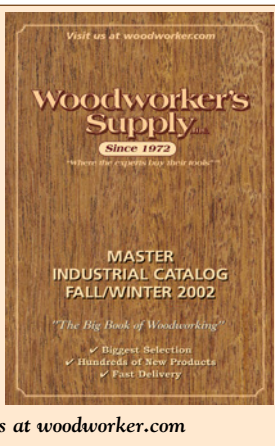

CIRCLE NO. 169 ON FREE INFORMATION CARD.

Collect Dust!

1.5hp - 20hp
Dust Collection
Systems & Components

- ▶ **FREE** Ductwork Design Service
- ▶ **FREE** Product and Ductwork Catalog!

Call Us Today!

1.800.732.4065

Online Ordering
www.oneida-air.com

1001 W. Fayette St., Syracuse, NY 13204



CIRCLE NO. 143 ON FREE INFORMATION CARD.

The Cutting Edge

Finally, a saw you can depend on with a name you can trust. Our new MM series bandsaws feature huge resaw capacities, loads of cast iron, and perhaps most importantly... a company that will stand behind it! Call one of our customer representatives today and discover how our cutting edge bandsaws can improve your woodworking.

Mini Max USA

2012 Centimeter Circle Austin, TX 78758

866-WRK-WOOD

(toll free 866-975-9663)

www.minimax-usa.com



Video
Now
Available!

CIRCLE NO. 139 ON FREE INFORMATION CARD.

*Adams Wood Products*TM
LTD., L.P.

STOCK ITEMS
NO MINIMUM ORDERS
-OR-

WE WILL MAKE PRODUCTION RUNS OF YOUR PART

Made in Tennessee
By American Craftsmen

913 LEGS

113 REEDED BASE W/206 LEG

404 CHAIR KITS

ACR08

AMD08

BUN LEGS

A0556

FINIALS

A0851

FR STYLE QUEEN ANNE LEGS

P.O. Box 728, Dept. PW17
Morristown, TN 37815-0728
Phone 423-587-2942 • Fax 423-586-2188
www.adamswoodproducts.com

FREE COLOR CATALOG

CIRCLE NO. 100 ON FREE INFORMATION CARD.

You already know
BOSCH power tools.

Now meet a
BOSCH tankless water heater.



BOSCH AquaStar

Another **BOSCH** Innovation for Tankless Water Heating

When it comes to power tools, BOSCH has long been the brand of choice. Now, the same quality you trust in your tool chest is available in a water heater. This new technology generates the pilot spark from the flow of water. Like a hydro dam producing electricity, the 125HX system ignites the burners when water is flowing without the need for electricity or batteries. This patented technology provides the ultimate in efficiency, longevity, and simplicity of heating water.

- **Endless Hot Water**
- **Save Energy & Money**
- **Built to Last**
- **Available in LP or Natural Gas**

Exclusively distributed by:

CONTROLLED ENERGY CORPORATION | www.ControlledEnergy.com/pw | 800.642.3199

APPW

CIRCLE NO. 110 ON FREE INFORMATION CARD.

DeWalt: A Little Late but Great



Photos by Tim Grondin

SPECIFICATIONS

DW618PK Router System

Street price: \$235 - \$250

Motor: 12 amp, 2¼ hp, 8K to 24K rpm with soft start, electronic feedback

Collets: ¼" and ½"

Plunge stroke: 2½"

Weight: 12 pounds

Performance: ●●●●●

Price range: \$ \$ \$ \$ \$

DeWalt Tools: 800-4-DeWalt, or dewalt.com

I don't know if DeWalt did it on purpose, but by offering a multi-base router system after three of its competitors had brought their models to market, DeWalt was able to add some features and innovations that make its system superior.

One of the nicest features is the quick-release motor latches that allow you to slide the motor out of either base by releasing a cam lock, then depressing the two release latches. This same system allows height adjustment in the fixed-base version by rotating the depth adjustment collar (graduated in 1/64" increments) without spinning the motor. This keeps your switch and cord in the same place at all times, and you won't experience problems with bit concentricity.

Also nice is the detachable, locking 10' rubber cordset. This not only makes replacing the cord easy (after accidents or wear), it also makes using the optional D-handle base (\$80) simple. The cord is so convenient that I disconnect it from the motor while changing bits instead of unplugging the tool. It makes the motor less awkward and leaves the cord connection at bench height, rather than chasing the cord end on the floor to plug it back in when you're done.

The motor also has a flat top and spindle lock to make bit changes convenient. If you don't like the idea of using a spindle lock, the lock is removable, and DeWalt has included the necessary two wrenches. The switch on the motor is a sealed toggle switch located for easy thumb access.

The motor on the model we tested was a 12-amp, variable-speed motor (a single speed model, the DW616, also is available) with soft start and electronic feedback to main-

tain constant speed under load. Rated at 2¼ horsepower by DeWalt, we found the torque and power excellent for this size tool.

Both bases included in the kit have rubber overmolded handles that are sized well and provide a good, no-slip grip. They also share clear, Lexan base plates offering good visibility of the cutting operation.

The plunge base is a nod toward the convenience of the DW621 plunge router, without going so far as to steal sales from that nice tool. The motor slips easily into the plunge base housing, locking in place again with a cam lock. Machined brass bushings provide smooth plunge action with a convenient and well-sized plunge lock lever.

Depth adjustment is accomplished through a five-position turret stop (with 5/128" adjustment per turn) and a slip-knob on the depth rod that allows for quick, temporary depth adjustment before locking in the final setting for your plunge cut.

The plunge base offers through-the-base and column dust collection, (one of the best features on the 621 model) providing easy

hook-up to a shop vacuum for excellent dust collection without impeding use.

One drawback with the motor in the plunge base is the speed control knob is more awkward to adjust than in the fixed base.

When we put it to use, the router performed well, felt good in our hands and was easy to adjust and transfer from one base to another. Vibration and noise were within comfortable levels, but not the best in the class. Priced between \$230 and \$250, it's priced competitively, and offers nice refinements that make it a strong recommendation in the multi-base router category.

For more information, circle #115 on Free Information Card.

continued on page 32

HOW WE RATE TOOLS

We test new tools and products with an honest, real-world workout. We start from the box, assemble the tool if necessary, and read the manuals to see how clear they are. Then we put the tools to use in our shop, building projects. Then our staff shares the result with you.

We rate performance on a one-to-five scale, with "five" indicating that we consider it to be the leader in its category. For price range, five dollar signs means the tool is priced high in the category, with one dollar sign indicating a low price. Three dollar signs is an average price.

If all your questions aren't answered here, e-mail me at david.thiel@fwpubs.com or call me at 513-531-2690, ext. 1255. You also can visit our web site at popularwoodworking.com to read previous tool reviews and sign up for our free e-mail newsletter (focusing on tools) that's sent out every other week.

—David Thiel, senior editor



Forrest Saw Blades

America's Best Since 1946!

"You Can Count On Us For Quality, Performance, and Dependability!"

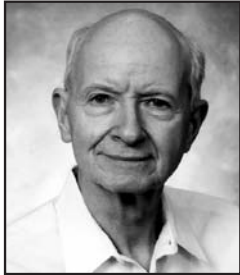

Jim Forrest, President

"For almost 60 years, our company has manufactured top-quality saw blades that eliminate or reduce splintering, scratching and tearouts, and we've offered the finest in-factory sharpening available anywhere. We use only high corrosion-resistant C-4 carbide for extended use between sharpenings. And now all Woodworker I and II blades 10" or larger have 30% more carbide than before...for the longest possible blade life.

"Here's our no risk-guarantee: **Purchase any Forrest blade or dado and use it for up to 30 days. If you are not completely satisfied for any reason, return it for a full refund. You have my word on it!**"

New Discounts!
Save 10% on one (1) blade or dado!
Save 14% on multi-blade/dado orders!

Woodworker II

ALL PURPOSE - table saws and portable circular saws.

Size	Price
12" x 40T x 1"	\$131
10" x 40T (1/8" or 3/32" K)	\$121
10" x 30T (1/8" or 3/32" K)	\$101
8 1/4" x 40T (3/32" K)*	\$101
8" x 40T (3/32" K)	\$101
7 1/4" x 30T (3/32" K)	\$ 71
5 3/8"x40Tx10mm (5/64" K)**	\$ 83

Also available: 14"x40Tx1" • 14"x30Tx1" • 12"x30Tx1" • 16"x40T • 9"x40T • 16"x30T • 9"x30T • 8"x30T(3/32"K) • 6"x40T(3/32"K). Call for prices.

*For Sears & Makita **For DeWalt Cordless Portables

Now with 30% more carbide!



Fine Woodworking EXCELLENT

Customized Woodworker II

For the advanced table saw operator. Ideal for joinery and special uses!

Size	Price
10" x 40T (1/8" K) #1 grind for square cut box joints.	\$132
10" x 40T (1/8" K) #6 grind for near flat bottom, easy feed.	\$132
10" x 40T (1/8" K) Dovetail joint grind. Specify angle & left or right points. See Fine WW12/01.	\$132
10" x 40T (5/64" K) Ultra thin kerf for precision work. Use stiffener plate.	\$141
10" x 20T (1/8" K) Fast feed rip for thick hardwood without burning.	\$ 71

Now with 30% more carbide!



Dado-King

You get flat-bottomed grooves and no splintering—even when crosscutting oak plys and melamine. This award-winning set comes with six 4-tooth chippers (including 3/32" chipper), two 24-tooth outside blades plus shims. Cuts 1/8" to 29/32" grooves.

Size	Price
6" set	\$271
8" set	\$291
10" set	\$349
12" set	\$449



AMERICAN EDITORS' CHOICE WOODWORKER

FREE \$21 value! 10" Blade Runner carrying case. Protects and holds up to 10 blades. Ships with 6", 8", or 10" Dado sets. Included free with your order!

Chop Master

Specially designed for sliding compound miter, miter-chop, and radial saws.

Size	Price
7 1/2" x 60T x 5/8" Makita Cordless Slide	\$101
8 1/2" x 60T x 5/8" Hitachi, DeWalt, Ryobi, Freud TR125	\$121
10" x 80T x 5/8" Delta, Bosch, Hitachi, Makita, Ryobi, AEG & all	\$141
12" x 80T x 1" Delta, Hitachi, Makita, B&D, Sears & all	\$151
15" x 100T x 1" Makita, Ryobi	\$199

Also available: 8 1/4" x 60T • 6 1/2" x 40T • 9" x 80T • 14" x 100T. Call for prices.



NEW!

Duraline HI A/T

Cuts melamine perfectly. 220mm & 300mm available. Our best plywood blade.

Size	Price
10" x 80T (1/8" or 3/32" K)	\$161
12" x 80T x 1" (1/8" K)	\$181

Also available: 14"x100Tx1" • 14"x80Tx1" • 16"x100Tx1" • 8" • 7 1/4" and others. Call for prices.



Woodworker I

Designed for radial arm or tablesaws—fine crosscut.

Size	Price
7 1/4", 8", 8 1/4" x 60T	\$111
10" x 60T	\$131
12" x 60T	\$141

Also available: 9" x 60T • 14" x 60T • 16" x 60T. Call for prices.

Now with 30% more carbide!



Two Easy Ways to Order

Call toll-free

1-800-733-7111

Visit our internet store

stores.yahoo.com/forrestman

(In NJ, 973-473-5236)

Fax 973-471-3333

Se habla español

Western Canada: Call Sharp Tech, Inc.

877-228-0908 • Fax 403-225-3767

Other Canadian Sales: Call CMR - Ron Collier

800-229-4814 • Fax 989-684-0402



DON'T SEE WHAT YOU NEED?
Call us for other blades and dampener discs!

\$15 OFF* OUR EXPERT BLADE SHARPENING!

Don't take a chance with micro-chipped edges on your expensive wood! Our in-factory sharpening preserves the life and performance of all types of carbide blades. In fact, Forrest Manufacturing represents the industry standard for fine quality sharpening. Most orders processed in 3 to 5 days. You'll receive \$15 in DISCOUNT COUPONS* for our expert factory sharpening with every new Forrest blade or dado you purchase! Coupons can be used to sharpen any carbide blade. (Please include return UPS of \$7 + \$1 for each additional blade.)

FORREST Forrest Manufacturing Company
457 River Road
Clifton, NJ 07014

FREE SHIPPING—
All Orders Over \$275
Other orders, please add:
Saw blade - \$7 • Dado - \$9 • Stiffener - \$3

*3 coupons at \$5 each, use 1 coupon per blade.

© 2002 Forrest Manufacturing Company, Inc.

TOOL TEST

continued from page 30

Senco's New Kits are Affordable and Good Quality

It's getting less expensive to own a pneumatic nailer every day. Senco has just unveiled three new combo kits that should sell like hot cakes – or hot dogs, in this case.

The new kits each include a 1-horsepower, 1-gallon hot dog-style compressor with a 120-psi capability. This is one of the quietest compressors we've ever heard, and very handy to carry around. You aren't going to frame a house with it, but it's adequate to power the nailers offered in the kits for any home (and most small shop) needs.

The pneumatic nailers offered in the kits are some of the newest and best Senco has to offer. The FinishPro 18 kit sells for \$180

and offers the compressor, hose, fittings and an 18-gauge, ($\frac{5}{8}$ " to 2" capacity) brad nailer. The similarly equipped FinishPro 15 (\$160) includes a $\frac{5}{8}$ " to 1 $\frac{1}{4}$ " capacity 18-gauge brad nailer, and the FinishPro 2N1 (\$180) offers a dual-purpose nailer/stapler with $\frac{1}{2}$ " to 1" staple and $\frac{5}{8}$ " to 1 $\frac{1}{4}$ " brad capacities.

We were able to fire 10 brads before the compressor kicked on, and were able to continue firing at a reasonable pace without any loss in performance. These are well-priced and well-thought-out systems for the home woodworker who needs a system that is small but still provides excellent performance.

For more information, circle #152 on Free Information Card.



SPECIFICATIONS

Senco FinishPro Combo Kits

Street price: \$160 to \$180

Performance: ●●●●○

Price range: \$ \$ \$ \$ \$

Senco: 800-543-4596 or senco.com

Glen-Drake Chisel Hammer Feels Perfect in Your Hand

When chopping with a chisel, you need two hands and three eyes. Two of the eyes watch the chisel to ensure it's perpendicular, and the much-wished-for third eye guides your hammer to the back of the chisel handle.

The new series of chisel hammers from Glen-Drake Tool Works (makers of the great Tite-Mark marking gauge) are designed so you could use them in the dark. The handles are so perfectly shaped for your hand that you can pick them up from your bench and the hammer will fall naturally into position without a glance at the tool.

Made from recycled tanoak, the handles are rived by hand and shaped by a CNC machine to the asymmetrical but palm-fitting shape. The head is brass and has flat and domed heads. The flat head is for plastic chisel handles; the domed is for wooden ones.

Kevin Drake, the inventor of the hammer, gave us a great lesson on using any chisel hammer based on techniques used by percussionists. First, squeeze the hammer to lift it above the chisel's handle.

Relax your hand a bit to let the hammer fall and add a little throwing motion as it falls – but release that right as the hammer strikes the handle. Your hand and wrist should be relaxed on impact.

Your chisel will cut just as well as if your hand were tight on the handle, but with much less effort on your part. Chopping is such a common operation that you should have a tool that makes things easier. The Glen-Drake hammer not only makes chopping easier, but more accurate, too. **PW**

— Christopher Schwarz

For more information, circle #122 on Free Information Card.



SPECIFICATIONS

Glen-Drake Chisel Hammers

Street price: \$39 to \$49

Sizes: Four weights; #1 is 6 oz., #2 is 9 oz., #3 is 11 oz., and #4 is 14 oz.

Materials: Tanoak and brass

Performance: ●●●●●

Price range: \$ \$ \$ \$ \$

Contact: Glen-Drake: 707-961-1569 or glen-drake.com

Bosch's New Cordless Jigsaws

Bosch has been making some of the best jigsaws in the world for decades and the company has now upped the ante in the cordless market. The three new cordless jigsaws (in 14.4-, 18- and 24-volt models), do an admirable job of offering near-corded performance. It won't cut quite as fast, and thicker materials slow it down, but it's not a wimpy tool. Add to this the excellent blade ejection and replacement feature and you've got a nice tool. They all include a 1-hour charger, offer a 1" blade stroke, variable speed, four orbital-action settings, chip blower and a pivoting foot plate. The saws can handle material up to 2 $\frac{1}{2}$ " thick. We found the 14.4-volt model to be well balanced, with easy battery removal. We noticed blade deflection on hard turns, but nothing that we haven't seen on dozens of corded jigsaws as well. The 14.4 model (52314) costs about \$175. The 18 volt is \$250 and the 24 volt is \$280. Though pricey, they're well made and perform well.



Bosch Tools: 877-BOSCH-99, or boschtools.com

THE WOODTURNERS CATALOG

- Best Selection
- Best Service
- Satisfaction Guaranteed!
- FREE Catalog Available-

1-800-551-8876

www.woodturnerscatalog.com



CIRCLE NO. 111 ON FREE INFORMATION CARD.

New from ...

Lie-Nielsen
TOOLWORKS
INC.

Boggs Spokeshave \$125

P. O. box 9, Warren, Maine 04864
1-800-327-2520

www.lie-nielsen.com

CIRCLE NO. 136 ON FREE INFORMATION CARD.

New! All Pro Professional Series Band Saw Blades



Super hard edge tempered back band saw blades.

For use by professional woodworkers and craftsmen in industrial, woodworking, and furniture manufacturing applications.

The most efficient, long lasting blades with induction hardened teeth for cutting wood, plastic, and non-ferrous metal.

Visit Your Olson Dealer and Ask for the New All Pro Blades.

Dealer Inquiries Welcome!
Call: 203.792.8622

OLSON®

THE OLSON SAW COMPANY

16 Stony Hill Road, Bethel, CT 06801 • www.olsonawsaw.com
Manufacturers of Fine Quality Saw Blades Since 1918

CIRCLE NO. 142 ON FREE INFORMATION CARD.

JDS AIR-TECH and Dust-Force

When only the **Best** will Do!

New!

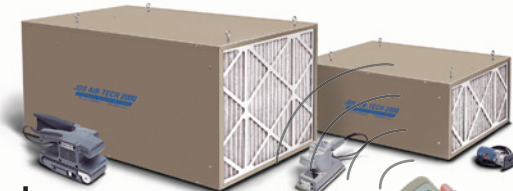

\$289.00

Model 750-ER

JDS, the leader in quality air filtration products, introduces the ultimate air cleaner for your shop (**Model 750-ER**). This remote controlled unit will clean the air in a 30'x30'x8' shop once every ten minutes. For larger areas the models 8-12, 10-16, and 2400 are available. To remove odors, fumes and smoke, order our optional charcoal filter.

Model 750-ER

When only the **Best** will Do!

- LCD Remote Control with speed and timer function
- Highest Maximum Air Flow in its Class 1,050 CFM (750 CFM Filtered Air)
- 95% ASHREA Tested main filter (91% Efficiency at 1 micron - 99% at 5 microns)
- Washable Electrostatic Pre Filter With ten year manufacturer's warranty

Put the Force to work in your shop...

Our new 1.5 HP **Dust-Force** is the perfect addition to our award winning line of air filtration units. Powerful, portable, and ready to work for you, the **Dust-Force** will make your shop a cleaner, healthier, more productive environment.

\$299.00

Specifications

Motor.....1.5 HP
Max CFM..... 1250
Fan.....11"
Inlet Dia..... 1-5"/2-4"
Bag Capacity..... 42 gallons
Decibels..... 67-77
Electrical..... 110/220
↳ Switch Prewired for 110V



Another quality product from

JDS COMPANY

To place an order or for the dealer nearest you call us toll free. 1-800-480-7269

www.thejdscompany.com

CIRCLE NO. 127 ON FREE INFORMATION CARD.

Well-tuned Woodworking

You can build a harp, but it takes a maestro to build a lyrical instrument.

As woodworking projects go, a harp isn't a very complicated one. It's fairly simple joinery and doesn't require much in the way of specialized machinery. While many woodworkers could produce an attractive structure, it takes a passionate, trained expert to make this stringed frame sing like the voice of an angel. William Rees is one of those experts.

Rees's background wouldn't lead you to believe he could be one of the top harp luthiers in the country. Originally a high school science teacher with a degree in biology, Rees grew up playing classical guitar and started building instruments as a hobby. Not content with mainstream guitars, he opted for more esoteric instruments such as harpsichords, lutes and eventually harps.

He brought his technical knowledge of guitar and violin making, and applied it to harps with melodious results.

His passion turned to business as he fine-tuned his harp-making skills and found a

While William Rees has a hand in every stage of production in the shop, he gets the final touch on each harp, stringing and tuning the instrument to ready it for sale or delivery.



market for his harps. His harps run from around \$850 on up to \$6,000, with the average price less than \$2,000. His customers include professional performers such as Celtic harpist Carol Thompson (who records on the Dorian label) and television star Hal Linden ("Barney Miller") who, we understand, is an accomplished musician. Neil Young even purchased a Rees harp; but it was for his wife and son, so fans shouldn't look for a forthcoming harp album.

Born and raised in northern California, Rees and his family (wife Pamela, and sons Garen and Bryant) moved east to be closer

to the majority of their customers, and because of the strong music and arts programs in schools in the Midwest. Harps on Main, the company's name, is truly a family business. His wife spent years working as a contractor for the defense department as an optical physicist and now is the company's business manager. Garen adds decorative details to the harps, applying his artistic talent into the painted designs and carvings. Bryant follows Dad's skills doing the woodwork on the harps. Rees is happy to plan for the day when his sons will take over the business.

The family chose scenic Rising Sun, Ind., because of its central location and small-town atmosphere. They also got a great deal on the turn-of-the-century speakeasy-turned-meeting hall, right on Main Street, and they discovered they were on the cutting edge of a cultural revolution in the city. While business continues to grow and thrive there, the comfortable, small-town feel remains.

Building a harp requires a good knowledge of design, some trial and error, and exacting construction quality to make sure the instrument is stable and strong. But the construction itself is fairly simple, requiring mostly glued butt joints, some doweling and basic box construction. A certain amount of artistic flair is allowed in the shape of the pillars and necks, and decoration adds opportunities for personalization and whimsy.



William's son Garen is the detail expert in the shop. He adds the decorative touches that personalize all of the harps, making each one unique. The decorations include painted Celtic or other designs, and applied carvings. Harps on Main prefers applied rather than relief carvings because they stand out more from a distance, such as from a concert-goer's seat.

OUTPERFORMS SAWS TWICE ITS PRICE.



A MODEST
CLAIM
BACKED BY
CARBIDE-TIPPED
TEETH.



BT3100 10" Table Saw
SKU# 348-281

Incredibly, for under \$300, the Ryobi BT3100 gives you the 15-amp power to cut 4x4s in one pass. The big-job capacity to rip 30" to the right and 31" to the left of the blade. The surgical precision of a sliding miter table and triple-axis, self-aligning rip fence. The solid support of an all-metal work stand. And the confidence of a 30-day, no-risk satisfaction guarantee. There's no saw like it at anywhere near the price. And it's waiting at The Home Depot® right near you.

Ryobi Technologies, Inc. 1428 Pearman Dairy Road, Anderson, SC 29625 USA 1-800-525-2579
Prices Subject to Change Without Notice. All pricing in US dollars. OTC: TTNDY

CIRCLE NO. 151 ON FREE INFORMATION CARD.



Pro Features.
Affordable Prices.™
www.ryobitools.com

GREAT WOODSHOPS

continued from page 34

Harps on Main has its workshop in the rear of the first floor, with showroom and classroom space up front, and concert and office space on the second floor.

The machining area is home to tools that could be found in most home shops. An old Craftsman contractor saw does the majority of the parts sizing, with a variety of jigs to make setups simple and accurate.

Other machinery includes a number of economy tools from Harbor Freight, a Performax sander that sees lots of work, a standard 14" Jet band saw, three Grizzly sanders and Rees's favorite tool, a Delta Bench Oscillating Spindle Sander (B.O.S.S.), that takes hours off his work load.

Rees is a strong believer in not wasting lumber, both for ecological and business reasons. To do his part he works with mostly re-sawn lumber and thin hardwood panels. He prefers to do his resawing on the table saw, though. He uses a standard, no-nonsense combination blade and has carefully planned his designs to use wood widths for his panel glue-ups that can easily be resawn on the table saw. He also doesn't waste wood that others might consider unappealing. Sapwoods and defects are incorporated into his designs.



The sound box's backs finish out at $\frac{1}{4}$ " thick. To avoid lots of waste, the four-piece backs are resawn, then planed to $\frac{5}{16}$ ", then edge glued. The special clamps (from Woodworkers Warehouse) allow Bryant Rees to make a thin-slab glue-up with reasonable ease.



A broad view of the shop shows machinery staged along the right wall and back end of the shop. The finishing area is behind the wall in the back left corner. Benchtop machinery is staged along the counter that runs the entire length of the left wall. Assembly and workbenches are centered in the room and accessible from all sides.

While traditional harps were made using spruce, Rees found with some trial and error that domestic hardwoods (cherry, walnut and even poplar for the sound boards) also provide excellent tone. Strength also is an important part of the design and construction. When strung, a medium-sized harp can have 1,250 pounds of pressure exerted on the 5mm-thick soundboard. After time, the soundboard will "belly" away from the soundbox because of the string pressure, so some resilience is necessary as well.

The finish on Rees's harps is kept simple. He uses a clear lacquer finish over the unstained woods, letting the natural colors and grain patterns speak for themselves.

Rees and his family have turned their passion for music and woodworking into a thriving business. That business brings joy not only to those who purchase his harps, but also to those who hear them played. If you'd like to view more of Rees's work and learn more about harps, visit the company's web site at traditionalharps.com. **PW**

—David Thiel



The heart, and most critical part of each harp, is the sound box. Making sure the soundboard will support the potential 1,250 pounds of pressure exerted on it by the strings demands careful attention. Painted luan templates for the many shapes used hang in easy reach on the side wall. They're painted so that everyone knows they're important and shouldn't be thrown away.

WHITECHAPEL LTD
THE WORLD'S FINEST HARDWARE
 Free 216 page color catalog: 1-307-739-9478
 Web: whitechapel-ltd.com



French armoire hinges available in six sizes.

CIRCLE NO. 160 ON FREE INFORMATION CARD.

STEVE WALL LUMBER CO.
 Quality Hardwoods and Woodworking machinery For The Craftsman and Educational Institutions

Ash	4/4	Select	2.40	\$ 85.00
Basswood	4/4	Select	1.95	\$ 72.00
Birch	4/4	Select	2.75	\$ 89.00
Butternut	4/4	1C	2.30	\$ 77.00
Cherry	4/4	Select	4.90	\$110.00
Hickory - Pecan	4/4	Select	2.85	\$ 89.00
Mahogany (Genuine) ..	4/4	Select	3.90	\$100.00
Maple (Hard)	4/4	Select	3.15	\$ 96.00
Maple (Soft)	4/4	Select	2.30	\$ 79.00
Poplar	4/4	Select	1.75	\$ 72.00
Red Oak	4/4	Select	2.50	\$ 88.00
Walnut	4/4	Select	4.00	\$100.00
White Oak	4/4	Select	2.50	\$ 88.00
Cedar (Aromatic Red) ..	4/4	1C+Btr.	1.80	\$ 72.00
Cypress	4/4	Select	2.40	\$ 80.00
White Pine	4/4	F.G.	1.20	\$ 62.00
Yellow Pine	4/4	Clear	2.00	\$ 74.00

UPS Specials

SEE OUR CATALOG ON THE WEB!

4/4 Log Run Walnut 100 bd. ft. \$160 Also Available Exotic Lumber

STEVE H. WALL LUMBER CO.
 BOX 287
 MAYODAN, N.C. 27027
 336-427-0637
 1-800-633-4062
 FAX 336-427-7588
 Email: wood@walllumber.com
 Website: www.walllumber.com

Send \$1.00 For Lumber Catalog
 Prices Subject to Change Without Notice

CIRCLE NO. 158 ON FREE INFORMATION CARD.

GENERAL INTERNATIONAL PRECISION WOODWORKING TOOLS



EXCEPTIONAL PRICING SERVICE & VALUE
 Made In Canada

GENERAL MACHINERY
 The only High Quality, Heavy Duty Line of Woodworking Equipment
 Tablesaws, Jointers, Mortisers, Lathes, Drill Presses and accessories including Modulus® Scoring Saw Attachment

www.woodworktools.com
ASHMAN TECHNICAL LTD.
 351 Nash Rd, N. Hamilton, Ontario, CANADA L8H 7P4
 Phone 905-560-2400 • FAX: 905-560-2404
1-800-668-5721

CIRCLE NO. 103 ON FREE INFORMATION CARD.

FREE!
WOODWORKING CATALOG



Check out our complete **EXCLUSIVE** line of jigs and shop tables for your band saw, drill press and router. **PLUS** thousands of other great products! Go to rockler.com/go/V3330 or call **1-800-403-9736** and order your **FREE** catalog today!

ROCKLER
 WOODWORKING AND HARDWARE
 Code 13121 Free USA

ByPhone 1-800-403-9736 ByFoot 1-877-ROCKLER ByNet www.rockler.com

CIRCLE NO. 170 ON FREE INFORMATION CARD.

THE BLADE THAT DOES IT ALL!

Introducing **THE PRESTIGE™ BLADE**



Amana Tool's® new **PRESTIGE™** blade cuts smoother and stays sharper longer – in both solid wood & man-made board!

Why change blades? The Amana Tool® Prestige™ is the only one you need!

The secret is Amana Tool's® superior blade technology:

- Massive (.105" thick!) tool-steel plate with copper plugs practically eliminates vibration.
- Precision-ground D-10 carbide teeth (20° ATB, 18° hook) are individually computer-verified for runout of less than 1/10,000" on all axis.

#PR1040 10 x 40T(ATB) WOOD/LAMINATE, PLYWOOD

\$49⁹⁵

- SUPERIOR PERFORMANCE
- AFFORDABLE PRICE

Available at an authorized Amana Tool® dealer near you.

Rated "EXCELLENT" for

- ✓ Ripping solid wood
- ✓ Crosscutting solid wood
- ✓ Ripping plywood
- ✓ Crosscutting plywood

Amana Tool®
 FOR OUR NEW CATALOG OR A DEALER NEAREST YOU CALL 1-800-445-0077.

Visit our web site at www.amanatool.com for a complete listing of online dealers.

CIRCLE NO. 101 ON FREE INFORMATION CARD.

Precision Stop for Every Tool's Fence

This jig is as useful as it is absurdly simple. With it you can stop easily on a dime.

Actually, you could stop right on the tip of Franklin D. Roosevelt's nose if you wanted to. This little stop can be easily and accurately adjusted to within a few thousandths of an inch. It's reversible, so it can face in any direction. And it will work with almost any tool in your shop that has a fence. Clamp it to a table saw, chop saw, drill press, router table, you name it. You can use it to position workpieces as you cut parts, drill holes or rout mortises – any operation that you need to repeat with precision.

Make the stop from a small scrap of hardwood. Double-bevel one edge to create a point – this will become the “stop edge.” When you use an ordinary block with a square edge as a stop, sawdust sometimes becomes trapped against the stop edge. This keeps the workpiece from butting up against the stop and hurts the precision of the operation. When the edge is pointed, however, the sawdust is pushed behind the point and doesn't interfere with your cut's precision.

Adhere patches of 120-grit sandpaper to the faces of the stop. These keep the stop from shifting when clamped to the fence.

To make the stop easily adjustable, install a #8-32 machine screw in the stop edge. Drill



This simple jig can be used as a stop anywhere you have a fence. And you can micro-adjust the stop using the machine screw (top). On a table saw, this jig is great for stop-cuts (above). On the drill press, repetitive operations (such as drilling mortises) are easier with this handy shop helper (right).

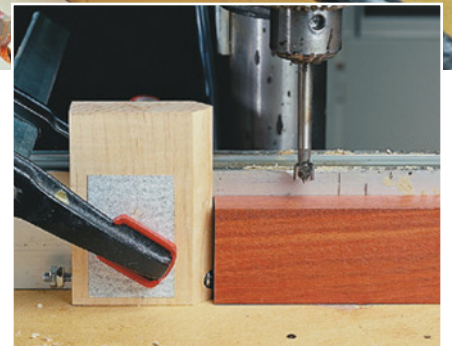

Photos by Tim Grondin

and tap a hole through the width of the stop. (You can tap hardwood with an ordinary metal tap; if you don't have a tap, drill an $1\frac{1}{64}$ " hole and the screw will tap itself as you drive it in.) Countersink the hole using a $\frac{3}{8}$ " Forstner at the pointed edge and thread the screw into the hole. Where the screw exits on the opposite flat edge, install two nuts and jam them together by turning them in opposite directions. This will create a knob with which to turn the machine screw.

When you need to fine-adjust the stop, use the slot in the head of the machine screw as a reference. Because the screw has 32 threads per inch, one full turn will move the

head precisely $\frac{1}{32}$ ". One half turn moves it $\frac{1}{64}$ ", one quarter turn, $\frac{1}{128}$ ".

And just in case you doubted the boast I made at the beginning of this column, the tip of FDR's nose is four and a quarter turns in from the edge of a dime. **PW**

by Nick Engler

Nick Engler is the author of more than 50 books on woodworking, plus countless articles. Currently, he's helping kids across America build ribs for a full-size replica of the first true airplane, the 1903 Wright Flyer.

Illustration by Mary Jane Favorite

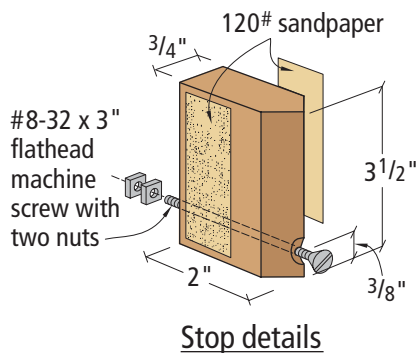

Make Ordinary Spaces Extraordinary!



Transform cluttered closets and cobwebbed corners into bright, beautiful, and functional storage spaces with the help of this valuable how-to guide! Professional woodworker Rick Williams will show you how to maximize your storage potential with simple woodworking techniques and a minimal number of tools.

With 10 creative projects in all, each equipped with step-by-step photos and instructions, you'll learn how to build a display case, three-sided curio hutch, built-in bookcase, grandfather clock, three-piece sectional entertainment center, and more!

Order your copy of *Creative Storage Solutions for Your Home* today!

#70534-K/\$24.99/128p/pb/200 color illustrations

Available at your favorite bookseller or directly from the publisher using the Order Form below.

ORDER FORM

YES! Please send me _____ copy(ies) of *Creative Storage Solutions for Your Home* (#70534-K) \$24.99 each

SUBTOTAL: \$ _____

In the U.S. please add \$3.95 shipping and handling for the first book, \$1.95 for each additional book. In OH, NY, CO and MI, please add applicable state tax. In Canada, add US\$5.00 shipping and handling for the first book, US\$3.00 for each additional book, and 7% GST. Payment in U.S. funds must accompany order.

TOTAL: \$ _____

Check or money order enclosed -or-
 Charge my VISA MC AmEx
 Acct.# _____

Expiration date _____

Signature _____

Name _____

Address _____

City _____

State/Prov. _____ ZIP/PC _____

Send to:  Popular Woodworking Books
 PO Box 9274
 Central Islip, NY 11722-9274

ZAC03PF

For more information or to order by Credit Card visit www.popularwoodworking.com/store/books or call toll free 1-800-448-0915

Save Money—saw your own lumber.



LT15G13 Personal Sawmill

\$4995

Make Money—saw for others.

- Cut logs up to 28" D. x 11' L.
- Extra bed sections permit longer lengths.
- Easily transportable.
- Video available.

Free Catalog!

Prices & specifications subject to change w/o notice.

Wood-Mizer®

Number One in Worldwide Sawmill Sales

www.woodmizer.com

8180 W. 10th St. Dept. PW6
 Indianapolis, IN 46214

Call for the location nearest you!

1-800-553-0219

CIRCLE NO. 163 ON FREE INFORMATION CARD.



The Solid Steel Staple Gun



MADE IN USA
 HECHO EN E.U.A.

Some Things Last Forever

Meet the ARROW T50®. It's the solid steel stapler that defines reliability. Compression spring action drives 6 different size staples – 1/4", 5/16", 3/8", 1/2", 17/32" (Ceiltile), and 9/16" – into hard woods, composition board, plastics – and even soft metals! It may not last as long as Stonehenge... but the durability of all steel construction, hardened high carbon steel working parts, comfortable easy squeeze double leverage operation and its patented jamproof mechanism... make the T50® the staple gun you can rely on for years to come.

Available at home centers, lumberyards, and fine hardware stores wherever professional tools are sold!



www.arrowfastener.com

©2003 Arrow Fastener Co., Inc.

Arrow Fastener Co., Inc.,
 271 Mayhill Street, Saddle Brook, New Jersey 07663
 Canada: Jardel Distributors, Inc.,
 6505 Metropolitan Blvd. East, Montreal, Quebec H1P 1X9
 United Kingdom: Arrow Fastener (U.K) Ltd.,
 Unit 5 ZK Park, 23 Commerce Way, Croydon CR0 4ZS, Surrey

CIRCLE NO. 102 ON FREE INFORMATION CARD.

Dado Joints

Four accurate ways to cut this important joint for building sturdy casework.

In casework of any size, using natural or man-made materials (or both), the dado is prime-choice joinery. It follows that hoary adage of woodworking: "Use the simplest joint that will work."

It certainly works. The dado joint is traditional, with a centuries-long history of use in cabinetmaking.

It definitely is simple. All dado joint variations derive from the cut itself. A dado is a flat-bottomed channel cut across the grain of the wood. (When it runs with the grain, the channel is called a groove.) You cut a dado or groove into one board, and the mating board fits into it. One well-placed, properly sized cut with the proper tool makes the joint. And with today's power tools, it's a cut that is almost trivial to make – if you know how.

The dado does not have to be deep to create a strong joint. One-eighth inch is deep enough in solid wood, 1/4" in plywood, medium-density fiberboard (MDF) or particleboard. The shallow channel helps align the parts during assembly, and the ledge it creates is enough to support the weight of a shelf and everything loaded on it. The dado also prevents the shelf from cupping.

The one stress it doesn't resist effectively is tension. In other words, it doesn't prevent the shelf from pulling out of the side. Only glue or fasteners can do that. Because all of the gluing surfaces involve end grain, the glue strength is limited.

Different Kinds of Dados

When the dado extends from edge to edge, it's called a through dado. It's easy to cut. The most common objection to it is that it shows. However, you can conceal the joint using a face frame or trim.

A dado or groove doesn't have to be through, of course. It can begin at one edge and end before it reaches the other (stopped),

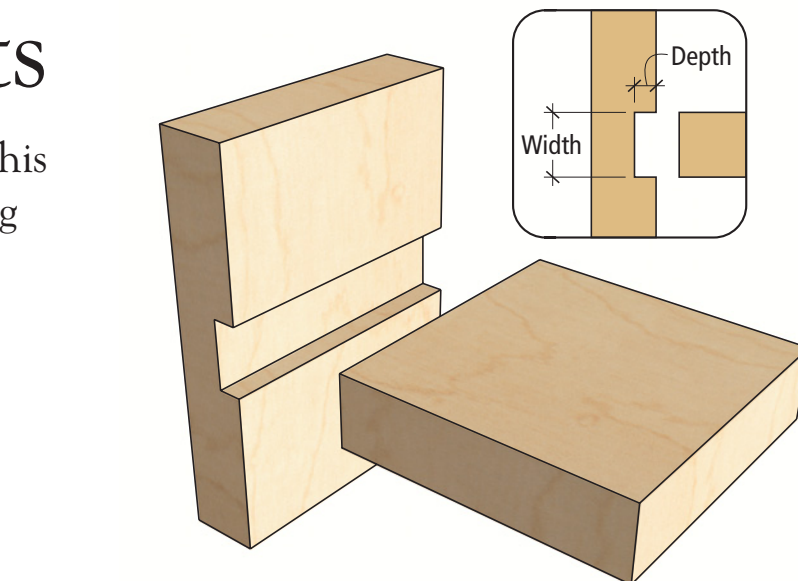

Through dado

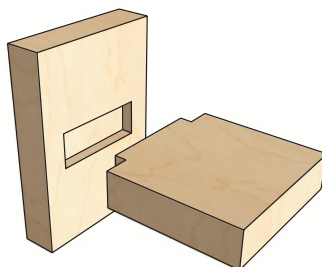

Blind dado

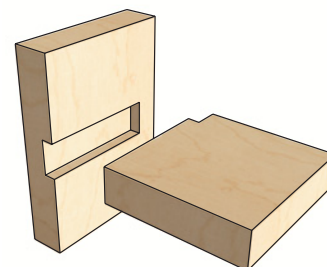

Stopped dado

or it can begin and end shy of either edge (blind). This version is a little trickier to cut.

To make a stopped or blind dado, the corners of the mating board must be notched, creating a projection that fits in the dado. Sizing the notches so you have a little play from end-to-end makes it easier to align the edges of the parts. But it does sacrifice a bit of the strength that the narrow shoulder imparts.

Cutting Dados

There are some other joints that begin with dados, but before I even mention them, let's deal with the basic joinery cut. There are scads of ways to cut a dado successfully.

Keep a couple of criteria in mind as you tackle the dado cut. To end up with a strong

joint, you need to make a cut of the correct width. The bottom needs to be smooth and flat, the sides perpendicular. If the cut is too wide, glue isn't going to compensate; the joint will be weak. Get the fit right.

The two most obvious power tools for cutting dados are the table saw and the router. But there are other options.

You can do dados with a radial arm saw. If you are comfortable with this machine, you probably can recite the advantages. Fitted with a dado head, the radial arm saw hogs through dados quickly. The workpiece is face up, so you can see what you're doing. Layout marks are visible, and you can line up each cut quickly. When a stopped dado is needed, you can cut to a mark. The work isn't moved during the cut, so the piece is less likely to twist or shift out of position. This is especially helpful on angled cuts, whether a miter or a bevel (or both).

I have cut dados on narrow workpieces using a sliding compound miter saw. Most

by Bill Hylton

Bill Hylton makes noise, dirt and the occasional piece of furniture in his basement workshop. His book "Chests of Drawers" (The Taunton Press) shows both his shop and his handiwork.

such saws have a cut-depth adjuster; you set the cut depth (with some trial and error), then “waste” each dado with kerf after kerf.

It’s one of those operations you do once, just to try it. And once was enough for me. I prefer to stick with my table saw and my router for cutting dados.

Table-saw Dados

Let’s look at the table saw first. It’s powerful and equipped with accessories – a rip fence and a miter gauge – useful in positioning cuts. Like a lot of other woodworkers, I use a shop-made cutoff box (instead of the miter gauge) for crosscutting – it also works for dados. To use the saw effectively for dadoing, you need a dado cutter, either a stack set or a wobbler.

You can waste a narrow dado pretty quickly with whatever blade is on the saw. If you’ve got a manageable workpiece and just one or two dados to cut, you make five to seven kerfs to form each one. But to cut a cabinet’s worth of dados, use a dado cutter.

If you’re making cabinetry assembled with through-dado joints, you can knock out a lot of consistently sized and placed cuts in short order. What isn’t necessarily quick and easy is achieving the precise width of cut you want. Stack sets, which give the cleanest cut, consist of separate blades and chippers. You have to select the combination needed to produce the approximate width of cut desired. To tune the cut to a precise width, you insert shims between the blades. It’s got more trial-and-error in the setup than I like.

Some woodworkers (those with too much time on their hands, I think) make a chart or a cut sample with notes on the combinations of blades, chippers and specific shims needed to produce common-width dados. If you have the patience for this endeavor, my hat is off to you. Go for it.

But the woodworkers most likely to use the table saw for dadoing are those who are looking at a lot of cuts and not a lot of time to make them. Often, these folks adopt workarounds to avoid protracted setups. They’ll shoot for an undersized dado, and then plane or sand the part to be housed in it to fit. Or they’ll use the dado-and-rabbet joint: The mating part is rabbeted to form a tongue that fits whatever dado has been cut.

How do you locate and guide the cut? The rip fence is seductive, because it allows you

to locate a cut consistently on both sides of a cabinet or bookcase. It eliminates the need for layout. But it isn’t a crosscutting guide, and dados are crosscuts.

Of the two crosscutting guides, I prefer the cutoff box. It’s built specifically for right-angle cuts and rides in both miter-gauge slots (instead of just one). In addition, it effectively immobilizes the workpiece, because the box is what moves, carrying the stationary workpiece with it. The work doesn’t squirm or twist as you push it into the cutter. Fit the box with a stop so you can accurately and consistently locate a cut on multiples without individual layouts.

Stopped cuts can be problematic, and blind cuts can be downright hazardous. Because the work conceals the cutter, and because the cutoff box conceals most of the saw table, it’s tricky to determine where to stop the cut. One good option is to clamp a stick to the outfeed table that stops your cutoff box at just the right spot.



Photos by the author

A dado stack set consists of separate blades, chippers and washer-like shims. You fit the elements onto the saw’s arbor, one by one.

A blind cut would require you to drop the work onto the spinning dado cutter. Not a routine that I’d recommend.

Any stopped cut done with a dado head will ramp from the bottom of the cut to the surface. You can leave it and simply enlarge the notch in the mating piece, but in so doing, you sacrifice the strength in the joint that comes from a tightly fitted shoulder. Better to chisel out the ramp.

Routing Dados

The router’s often touted as the most versatile tool in the shop, and it certainly is useful for dadoing. The cutters offer convenient



An accurate, shop-made cutoff box is the best guide accessory to use for dadoing on the table saw. Set the cutoff box on the sled base, tight against the fence. The work won’t shimmy or shift out of position as you slide the box across the dado cutter.



The typical router table setup works for dadoing parts like drawer sides. A push block – just a square scrap – stabilizes the work and backs up the cut, preventing tearout as the bit emerges from the cut.



Dado large workpieces on a router table with a cutoff-box-like sled. A stop clamped to the sled's fence locates the cut and immobilizes the work. Slides on the underside reference the edges of the tabletop to guide the sled.

sizing: Want a 1/2" -wide dado? Use a 1/2" bit. Want a dado for 3/4" plywood, which is typically under thickness? Use a 23/32" bit. Changing bits is quick and easy.

The tool also offers options on approach. If you have your router hung in a table, dadoing with it is much like table saw dadoing. But the router gives you the option of moving the tool on a stationary workpiece, and in many situations, this turns out to be the better approach.

On the Router Table

For a long time, my mantra has been that you can rout grooves on a router table more easily than you can dados. Consider the typical router-table setup. It's small in comparison to the typical table-saw setup, with its expansive infeed and outfeed tables. So I'd say, limit yourself to dadoing small parts only, things such as drawer sides.

Guided by the fence alone, you can easily rout grooves. The grain runs along a workpiece's long dimension, so a groove is easy to locate and cut guided by the fence.

But try guiding the workpiece's short dimension edge along the fence. Or locating a dado 16" from that edge. Or 24" or 30". Maneuvering a 6'-long bookcase side or a 24" by 36" base cabinet side on a router table top is a Keystone Kops routine. But a drawer side – where the piece is small and the dado (for the drawer back) is close to the end – can be routed pretty easily. You use a square-ended push block to keep the work square to the fence as you feed it and to back

up the cut. Large case parts are best done on the table saw or with a hand-held router.

Recently, however, I made a cutoff box-like accessory for my big router table. I don't like miter gauges (or the slots they require) on a router table, so the dadoing box I made is guided by the tabletop's edges (see the drawing below). I've dadoed some pretty large workpieces with it. The setup was sim-

ple, the operation downright easy and the results were clean and precise.

This accessory is changing my attitude, I must say. It offers all the advantages of the table saw-cutoff box setup, but eliminates the trial-and-error with the stack set.

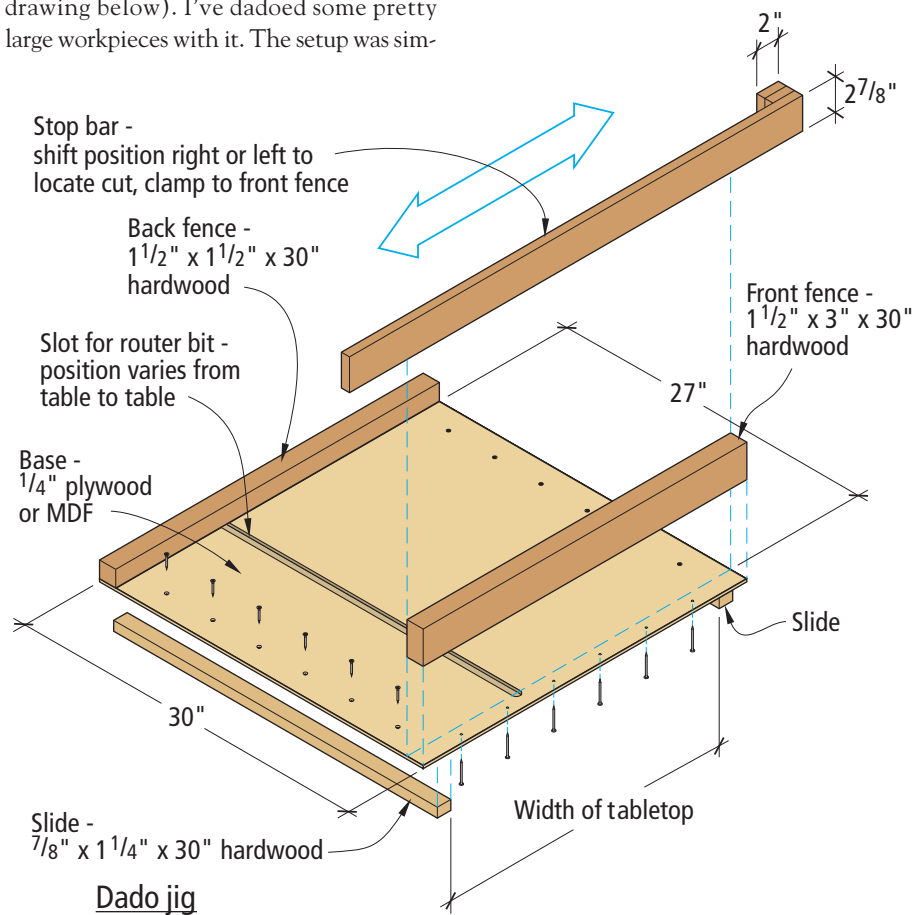

You do need to use a stop to position the work, because the stop also prevents the bit from moving the work. The bit in a table-mounted router is spinning counterclockwise, and it will pull work to the right. You put the stop on the right to counteract that dynamic. (It's the equivalent of positioning the fence on the right.)

With a Hand-held Router

I'm not ready to entirely abandon the router as a hand-held tool, however. It remains a prime choice for dadoing large workpieces, such as sides for a tall bookcase or base cabinet. It seems easier and safer to move a relatively small tool on top of a cumbersome workpiece than the other way around.

The big question is how you will guide the router for the cut. A shop-made T-square fits the bill, as does a manufactured straight-edge clamp such as the Tru-Grip. An accurate T-square doesn't need to be "squared" on the work, as a Tru-Grip-type clamp does, but positioning it accurately can be a trick.

A setup gauge is helpful here. Cut a scrap to match the distance between the edge of the router baseplate and the near cutting edge of the bit. Align one edge of the gauge on the shoulder of the desired cut and locate the T-square (or other guide) against the opposite edge. Bingo. The guide is set.

Though more elaborate to construct, my favorite dadoing jig is easy to position on simple layout marks, and it adjusts easily to cut the exact width of dado you need. You size the jig to suit your needs.

The jig has two 1/2" plywood fences, each laminated to a 1/4" plywood or MDF base strip. Both are matched to a particular router and bit by running that router along the fence, and trimming the thin base with the straight bit. One fence is then screwed to two hardwood crossbars.

Cutting a dado is foolproof. The router is trapped between fences and can't veer off course, regardless of your feed direction. Reference the left fence as you push the router away, reference the right one as you pull it back, completing the cut.



A crossbar attached at right angles to a plywood straightedge makes it an easy-to-align T-square guide for dadoing with a router. Clamp it securely to the work and the benchtop at each end.



The gap between the fence bases on my dadoing jig represents the cut width. Pinch scraps of the work material between them to set the jig.



Position the jig by setting the fence base edge directly on your layout line. The crossbars ensure it will be perpendicular to the reference edge.



POWER-TOOL JOINERY

The bars must be perpendicular to the fence, of course. The second fence is mounted so it can be adjusted toward or away from the fixed fence as shown in the photos.

Obviously, you cannot produce a dado narrower than the cutting diameter of the router bit, but you can do a wider one easily. Because the router is trapped between two fences, the feed direction is less of an issue and mis-cuts are unlikely.

The bases make it easy to adjust the cut width and to position the jig on simple layout marks. To do the former, use a scrap or two of the stock to be housed in the cut as gauges. Set them against the fixed-fence base, slide the adjustable fence into position and lock it down. To do the latter, align the fixed-fence directly on one of the marks, with a crossbar tight against the work's edge. Secure the jig to the work with two clamps. **PW**

Coming next issue: Bill Hylton shows you the best way to use your power tools to cut rabbets, another essential casework joint.

Dadoing cabinet sides? Clamp them edge-to-edge and rout both at the same time for cuts that line up perfectly.



Cabinet sides clamped edge-to-edge

For stopped or blind dados, clamp stop blocks to the jig (rather than the work). Move the jig, and the stops move with it. Using the plunge base eases beginning and ending these cuts.



Stop block

Precision & Safety Should Be Standard Equipment On Every

Tablesaw...

The Osborne EB-3 Miter Guide's innovative design ensures it is more rigid and stable than any other miter guide available. Over 40" of support. Accurate to within 1/30th of a degree.



...Now They Can Be



Fits Most Saws

The Merlin Splitter features tool-free removal and reinstallation, anti-kickback pawls and a thinner kerf design. Click-In, Click-Out convenience. See it at your local Woodcraft store or call us for a local dealer.

\$109.95 (M.S.R.P.)
Sears Model \$119.95 (M.S.R.P.)



1 800 357 4118

The *Ultimate* Woodworking System

www.excalibur-tools.com

CIRCLE NO. 117 ON FREE INFORMATION CARD.

STOP!

Before you buy your next tool, see how it performed in *Popular Woodworking's* workshop!

Just log on to popularwoodworking.com. There you'll find out how dozens of tools performed in the *Popular Woodworking* shop. Plus, each review lists key features and important facts you need to know to make a smart and savvy tool purchase. Check out this **FREE** service!

Log on today!

www.popularwoodworking.com

TIMBER WOLF BAND SAW BLADES FROM PS WOOD MACHINES

Distributors of Gschwind group

These Blades:

- guaranteed welds for life!
- run cooler, last longer, and do not wander!
- are made from silicon carbon steel, and have milled teeth
- produce a thin kerf.



Call for more information at (412) 831-5402 or **ORDER TOLL FREE: (800) 939-4414**
PS Wood Machines, 3032 Industrial Blvd., Bethel Park, PA 15102
www.pswood.com

CIRCLE NO. 147 ON FREE INFORMATION CARD.



The Woodworker's Edge...

BRIDGEWOOD®



PBS-440 Bandsaw...
designed and manufactured in Europe.
It runs quietly and vibration free.

FEATURES: 3 HP, 1 PH or 3 PH American made motor. Magnetic starter with thermal overload protection. Precision balanced cast iron wheels. Table slot for miter gauge use (Miter gauge optional). Blade tension indicator. Foot brake. Dust collection hookup. Cast iron rip fence. Heavy duty, European tri-bearing blade guides. Exclusive, double box beam frame design.

Wilke Machinery Company offers a full line of professional woodworking machines and power tools that are designed for any job. Next to "buying right the first time", from whom you buy is one of your most important purchase decisions. The Wilke sales staff pays special attention to customer support while offering competitive prices. The Service Department ensures your continued satisfaction with in-stock parts and technical know-how.

BW-8J Long Bed Jointer... could be the best 8" Jointer on the market today! It's surely a super value.

FEATURES: 9" x 66" table. 8" cutting width. 1/2" max. cutting depth. 1/2" x 8" rabbeting capacity. 4500 RPM, 4 knife cutterhead. 1-1/2 HP, 1 PH American made motor. 4" Dust hood. 4" x 36" easy to adjust fence...tilts inward and outward to 45° with positive stops at both positions as well as at 90°.



BW-310SL Sliding Spindle Shaper...
smooth-sliding table is supported by adjustable ball bearings. Excellent for end grain.

BW-002A Dust Collector...
portable, compact unit can solve your dust collection problems at a very low cost.

FEATURES: Metal impeller (not plastic). Bag attached with quick release metal straps. 2 HP, 1PH motor. 1059 CFM. One 5" or two 4" dia. hose inlets. 43.5 gal. collection bag. 1 micron filter bag.



FEATURES:
Sliding table.
Forward/reverse switch.
Two spindle speeds.
1/2-inch collet chuck.
Three interchangeable spindles. Magnetic starter.

For information and a

FREE CATALOG

contact us by toll free phone:

1-800-235-2100

visit our web page:

www.wilkemach.com

write or visit our showroom:

3230 N Susquehanna Trail, York, PA 17402-9716



QUALITY MACHINERY • PARTS • SERVICE • GREAT LEASE PLANS

CIRCLE NO. 161 ON FREE INFORMATION CARD.

Special Issues from Popular Woodworking!

Looking for some project inspiration? Want to find the perfect power tool to fit your needs and budget? Need the perfect backyard furniture? Want to turn that awkward space in your home into a storage area? Then look no further than the **Special Issues** from the editors of *Popular Woodworking*! Inside each, you'll find all the information you need: materials selection and cutting lists, step-by-step plans, exploded drawings, and clear direction.

**Storage & Shelving • Outdoor Furniture • Great American Furniture
Woodshop Essentials • Tool Buying Guides • Historic Projects • And more!**

Visit www.PopularWoodworking.com for a full selection of *Popular Woodworking* Special Issues, and more!

And don't forget to check your local newsstand for the latest from the experts at *Popular Woodworking*!





Learning to sharpen your edge tools will open up a lot of doors in woodworking. Sharpening is half the battle when learning handplanes, turning and carving.

Photos by Al Parrish

Sharpening

Plane Irons and Chisels

We've tried just about every sharpening system there is – from sandpaper to ceramics to waterstones. Here's how to get the best possible edge with the least amount of fuss.

When I took my first class in woodworking some years ago, the first thing the instructor showed us was his shop-made waterstone pond.

With a reverence and care reserved for religious artifacts and small injured animals, the teacher brought the pond out from its special place in his cabinet. For more than an hour he talked with a furrowed brow about secondary bevels, wire edges and polishing the back of our edge tools.

All of us in the class did our best to stifle our yawns. I kept looking at the rows of chisels and backsaws and wondered when we were going to get to the important part.

Within a week we all realized that we should have paid more attention to the sharpening lecture. Soon there were only two sharp chisels in the shop for a class of 10 students, and we quarreled over them. Trimming tenons with the equivalent of a butter knife was no fun.

So I made it a point to learn to sharpen well. And I've been fortunate to be able to use a variety of methods, including: oilstones, diamond stones, waterstones, ceramic stones, sandpaper, electric grinders and the Tormek system.

Each system has its good and bad points. Some are simple, others don't make a mess, some are less expensive and most systems can put an astoundingly good edge on tool steel.

For me, the two most important qualities a sharpening system needs are that it must be fast and it must produce the keenest edge. I'll pay a little more and suffer a little mess to get a good edge in a hurry.

That's because I'm more interested in woodworking than I am in the act of sharpening. I have no desire to look at my edges under a microscope or fret about tiny imperfections in the metal. I'm not the kind of guy who wants to meditate on my power animal as I proceed up to 500,000 grit. I want to be done with it and get back to the good part.

by Christopher Schwarz

Comments or questions? Contact Chris at 513-531-2690 ext. 1407 or chris.schwarz@fupubs.com.

Familiarity Breeds a Keen Edge

The steps I'm about to describe will work with every sharpening and honing system I know of on the market. That's because no matter what system you use, sharpening is about one thing: Grinding and polishing the two intersecting planes of a cutting edge to as fine a point as possible.

The tools you use to get there are up to you. But here are a few words of advice: Pick a sharpening system and stick with it for a good long time before you consider giving it up. Many woodworkers that I've talked to jump around from system to system, trying to find the best thing (and spending a lot of money).

If you stick with one system, your edges will improve gradually as you get better and better at using your particular set of stones or sandpaper. Skipping around from one system to the next will only stunt your sharpening skills.

Second, please buy a honing guide. It's a big old lie that these things slow you down. In fact, these simple and inexpensive guides are quick to set up and ensure your edge will be perfect every time you sharpen.

However, don't buy a whole rolling army of honing guides. I

GRINDING THE EDGE

To begin grinding your edge, put the tool in your honing guide and adjust it until the cutting bevel is flat on your stone. Eyeball it at first. After a couple passes on the stone you'll know if you're off or not.

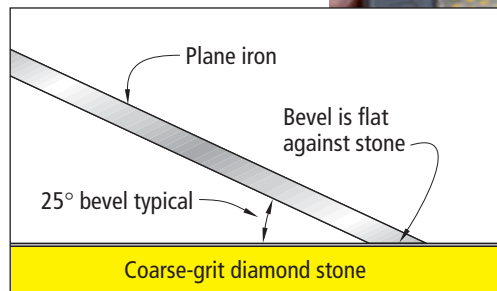

Flat-grinding your cutting bevel should not take long on a coarse diamond stone. If you're having trouble gauging your progress, color the cutting bevel with a permanent marker and you'll get a quick snapshot of where you stand.



use a \$10 Eclipse-style guide (the gray-colored side-clamp contraction shown in most of the photos) for sharpening my chisels and most plane irons. I also own the Veritas honing guide. It

excels at sharpening skew chisels and specialty plane irons that won't fit in the Eclipse guide, such as irons for shoulder planes.

Each honing guide holds the blade a little differently, and few of them are ever perfectly square. That's OK because what you're after with a honing guide is repeatability. Use the same guide over and over, and your edges will come out the same every time.

Polish Your Backside

There are three sharpening operations that must be performed on all chisels and plane irons that are new to you. First you must polish the flat backside (sometimes called the "cutting face") of the tool. Next you grind the cutting bevel. Finally you hone and polish a small part of that cut-

ting bevel, which most people call the "secondary bevel."

Keep in mind that these three steps are only for tools that you have newly acquired. Once you do these three things, maintaining an edge is much easier. You'll probably only have to polish the backside once. You'll have to re-grind an edge mostly when you hit a nail or drop the tool. Most sharpening is just honing and polishing the secondary bevel.

Begin with the backside of the tool. This is the side of the tool that doesn't have a bevel ground into it. It's one-half of your cutting edge so you need to get it right.

Start sharpening by rubbing the backside back and forth across a medium-grit sharpening stone or sandpaper. You don't need to polish the entire back, just the



If you don't polish the backside of your newly acquired chisels and plane irons, your cutting edges will always be jagged and easily dulled. You need to polish just the area up by the cutting edge. This is a process you'll only have to do once.



When you're done grinding, this is what your edge should look like.

area up by the cutting edge. I begin this process with a 1,000-grit Norton waterstone, then do the same operation with the 4,000-grit and then the 8,000-grit stone. The backside should look like a mirror when you're finished.

The Not-so-daily Grind

The next step is to grind the cutting bevel of the tool. You can do this on an electric grinder that has a tool rest, which will produce a slightly curved cutting bevel called a hollow-ground edge. Or you can do it on a coarse sharpening stone, which will produce a flat-ground edge.

Lots has been written about the advantages and disadvantages of each system. In comparing my hollow-ground edges vs. flat-ground edges I personally have found little difference between them in terms of edge durability.

I grind using a diamond stone for three reasons. First, it will never destroy a tool due to overheating (which can happen with electric grinders). Second, I use the diamond stone to flatten the waterstones. And third, the diamond stone is great for touching up my router bits.

I use DMT's extra-coarse stone for grinding my edges (800-666-

4368 or dmtsharp.com). Put the tool in your honing guide and set it so the cutting bevel is dead flat against the stone. Most tools come ground at a 25° bevel, which is good for most woodworking tasks. Mortising chisels should be set for 30°; tools designed for light paring only can be set for 20°.

Don't get too worked up about angles as you begin sharpening. Somewhere in the 25° neighborhood will be fine for most tools.

I use mineral spirits to lubricate my diamond stone. Most people use water, but a sharpening guru at DMT turned me on to mineral spirits. It evaporates slower than water and won't allow rust to build up easily on the stone.

Rub the cutting bevel against the diamond stone and check your progress. You want to grind the entire cutting bevel of the chisel or plane iron all the way across. If you set the tool proper-



When honing narrow chisels, this is the best way I've found to keep things steady and square. Put one finger on the cutting edge; put the other behind the jig to move it.

ly in the jig, this should be about five to 10 minutes of work.

As you progress on this coarse stone, you should make a substantial burr on the backside of the tool. This is called a "wire edge," and you'll want to remove it by rubbing the backside on your finest-grit stone a couple times.

Never rub the backside on your coarse stone. That just undoes all your polishing work there.

How you hold the jig is important, too. For plane irons and wide chisels, put a finger on each corner of the tool up near the cutting bevel and use your thumbs to push the jig. For narrower chis-

WHY I SWITCHED TO WATERSTONES

There are a lot of sharpening systems out there. And while I haven't tried every one of them, I've tried most. After much experimentation, I settled about five years ago on a system that used DMT diamond stones and oil-

stones. My system worked pretty well, but the oilstone part was slow, and my final cutting edge was always "almost" perfect.

Last summer I got my hands on a set of Norton's new American-made waterstones and it was like a door had been opened for me. These things cut wicked fast. And the edge they produce is darn-near perfect.

They feel different than many Japanese waterstones I've used. The best way to describe the difference is that the Norton stones give you different "feedback" as you sharpen. The 4,000-grit Norton actually feels like it is cutting (it is). The 4,000-grit Japanese

stones I've used have a more rubbery feel to them in use in my opinion. And they didn't seem to cut as fast at that level. The 8,000-grit Norton waterstone also provides great feedback to the user.

The downside to all waterstones is that they need to be flattened regularly. For this job, I use a DMT DuoSharp stone with the coarse grit on one side and the extra-coarse on the other. I also use this same diamond stone for grinding the cutting edge of all my chisels and plane irons.

The most economical way to get started with this system is to buy a Norton combination waterstone that has 1,000 grit on one side and 4,000 grit on the other. Then buy an 8,000-grit Norton waterstone for polishing. Norton also makes a 220-grit waterstone, but if you buy the DMT diamond stone you won't need it.

— Christopher Schwarz



Norton waterstones and the DMT DuoSharp stone are a great combination. The DMT handles the grinding jobs and flattens the Norton waterstones (800-446-1119 or nortonabrasives.com).

HONING THE EDGE

Before you begin honing the secondary bevel, loosen the clamp on your honing guide and nudge the blade backward in the guide about $\frac{1}{8}$ ".

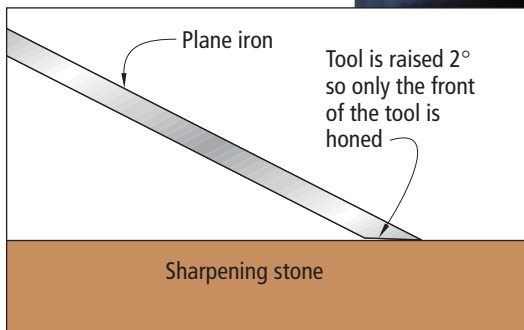

Begin with a 1,000-grit stone and rub the tool back and forth across the work. Try to wear the stone evenly by moving the tool in a regular pattern.



After a dozen licks, turn the tool over and remove the burr from the backside by rubbing it a couple times over the 8,000-grit stone.



After honing the tool on the 1,000-grit stone, this is what the secondary bevel should look like.

els, put one finger on the tool by the cutting bevel and push the jig from behind with one finger.

With the cutting bevel ground, it's time to refine the leading edge to a keen sharpness.

Honing: the Fun Part

Honing is quick and painless if your stones are flat and you've

done the first two steps correctly. The first thing to do is to reset the tool in your honing guide. Loosen the screw that clamps the tool and slide the tool backwards about $\frac{1}{8}$ ". Retighten the screw.

This will set the tool so only a small part of the cutting bevel will get honed. This speeds your sharpening greatly.

Start honing with a 1,000-grit waterstone, soft Arkansas oilstone or 320-grit sandpaper. I use the 1,000-grit Norton waterstone. Lubricate your stones as recommended by the manufacturer. Rub the tool back and forth on the stone. Turn it over and check your progress. You should see a secondary bevel appear up at the cutting edge. Rub your thumb along the backside; you should feel a small burr all the way across the cutting edge. If there's no burr, then you're not sharpening up at the edge; so continue honing until you feel that burr.

Once you have that burr, remove it by rubbing the backside across your 8,000-grit stone. Go back to your 1,000-grit stone and refine the secondary bevel some more until all the scratches on your secondary bevel look consistent. Use less and less pressure as you progress on this stone and remove the wire edge on the backside as you go.

Put the 1,000-grit stone away

and get out a 4,000-grit waterstone, a hard black Arkansas oilstone or 600-grit sandpaper. Go through the same process you did with the 1,000-grit stone. Remove the wire edge on the backside with your 8,000-grit stone. At this stage, the bevel should look a bit polished in places.

Finally, you want to polish the secondary bevel with your finest-grit stone or 1,500-grit sandpaper. I use an 8,000-grit Norton waterstone. There are Japanese waterstones at this grit level, too. However there are no comparable oilstones. A translucent oilstone is somewhat close.

Polishing is a little different. You're not going to feel a wire edge on the backside of the tool. Work both the secondary bevel and the backside of the tool on the 8,000-grit stone and watch the scratches disappear. When they're gone, you're done.

Test the edge using your fingernail – see the photo for details. Some people finish up by strop-

SHAPTON STONES: THE LATEST THING IN SHARPENING

If you think white-lab-coat wizardry is reserved for the manufacturers of power tools, think again. Some of the highest-tech science-fiction stuff happens in the knuckle-dragging hand tool industry: think unbreakable "nodular" cast iron, cryogenically treated tool steel and super-strong "rare earth" magnets that are incorporated into both tools and jigs.

And now the latest innovation is in sharpening. Shapton waterstones from Japan are all the rage among the sharpening gurus,

who say the stones cut faster and wear longer than other stones. They also can be expensive. There are several grades of the Shapton stones, and a basic setup of three stones can cost you anywhere from \$130 to \$220 – plus you'll need some way to flatten them.

We're using the stones in our shop now and will publish a full report in the coming months. If you want to check things out before that, visit shaptonstones.com or call JapaneseTools.com at 877-692-3624 for more information.

MORE HONING AND POLISHING



Continue honing the edge by switching to a 4,000-grit stone. Remove the burr on the backside with the 8,000-grit stone.

After working the 4,000-grit stone, here's what the secondary bevel should look like. It got a little bigger and it is more polished.



ping their edges at this point with a piece of hard leather that has been charged with honing compound. I don't find it necessary. In fact, if you're not careful, you will round over your cutting edge while stropping.

Remove the tool from your

honing guide, wipe it down with a little oil to prevent rusting and go to work on some end grain.

The tool should slice through the wood with little effort. And if that doesn't convince you of the value of sharpening, I don't know what will. **PW**



Repeat the same process on the 8,000-grit stone. You are almost finished. Tip: If your corners aren't getting polished, move the tool back $\frac{1}{32}$ " in the jig.

Polish the secondary bevel on the 8,000-grit stone until it is a mirror.

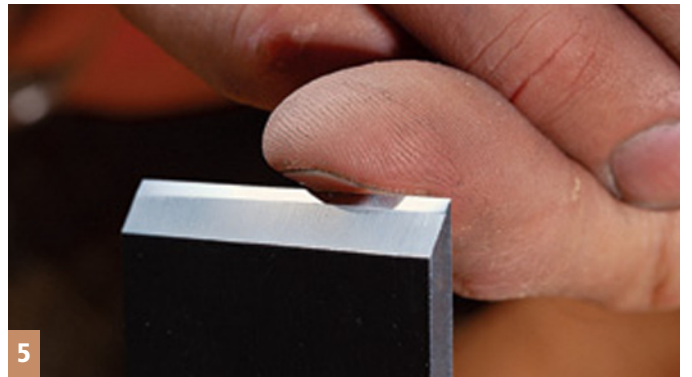

Here's how to test your edge without flaying your finger open. Pull your thumbnail across the edge at about a 90° angle. If the edge catches and digs in immediately, you're sharp. If it skids across your thumbnail, you have more work to do.

TWO JIGS FOR ALMOST EVERY JOB

There are a lot of honing guides on the market these days. After trying out most of them, I'm convinced these two will handle almost all your edge tools.

The gray side-clamp jig you see at every woodworking show and store is the workhorse in my sharpening kit. You can find this tool for about \$7 to \$13.



The Veritas jig will help you hone tools that would normally have to be sharpened freehand. It's a good investment.

None of these gray jigs I've inspected grind a perfectly square edge, but they're real close. Be sure to tighten the jig's clamp with a screwdriver when you fix the tool in the honing guide.

The Veritas guide (Lee Valley Tools, 800-871-8158 or leevalley.com) can handle many oddball tools. It easily clamps skew chisels, shoulder-plane blades, irons that are tapered in width and some not-so-stubby Japanese chisels. I don't use this jig as much for my run-of-the-mill plane blades and chisels with straight sides. It's much easier to clamp these in the gray side-clamp jig and go.

SUPPLIES

Woodcraft
800-225-1153, woodcraft.com

Side-clamp honing guide
Item # 03A21, \$12.99

DuoSharp 8" coarse/x-coarse
Item # 140966, \$79.99

Norton 1,000/4,000 waterstone
Item # 818263, \$54.99

Norton 8,000 waterstone
Item # 822462, \$89.99

Veritas honing jig
Item # 03B41, \$24.99

Lie-Nielsen (800-327-2520 or lie-nielsen.com) sells the Norton stones. The 1,000/4,000 stone is \$45; the 8,000 stone is \$75.

Prices correct at time of publication



GUSTAV STICKLEY'S
NO. 72

Magazine Cabinet

Thanks to Harvey Ellis, this set of Arts & Crafts shelves has subtly tapered legs and arched top rails that transform it from stocky to stylish.

If you had been shopping for a magazine cabinet in 1910 and came across this piece in Gustav Stickley's catalog, chances are you would have turned the page with barely a glance.

The photo of the No. 72 Magazine Cabinet in the 1910 catalog is horrible. Someone in Gustav Stickley's art department mangled the picture, and it bears almost no resemblance to the real thing. The legs look both spindly and lumpy. The shelves don't look sturdy at all.

In real life, this piece of furniture is impressive. It was one of several pieces of furniture designed by Harvey Ellis, an architect, painter and designer. Ellis's short stint with Gustav Stickley's company before Ellis' death in 1904 was remarkably fruitful. Under his talented pen, a fair number of Stickley's massive and overbuilt furniture forms became lighter and a bit more graceful.

by Christopher Schwarz

Comments or questions? Contact Chris at 513-531-2690
ext. 1407 or chris.schwarz@fwpubs.com.

Photo by Al Panish

The No. 72 Magazine Cabinet is a good example of this period. The curved top rails and tapered legs all conspire to make this piece look more delicate than it is.

Like most Arts & Crafts projects, this one is straightforward to build. I used about 15 board feet of 4/4 mahogany, four board feet of 5/4, and six board feet of 8/4—I had a little wood left over, but that always beats a second trip to the lumberyard. The plans for this project were developed by Robert W. Lang for his new book “More Shop Drawings for Craftsman Furniture” (Cambium Press, 800-238-7724). This is Lang’s second book of Craftsman furniture plans, and it features measured drawings for 30 pieces of museum-quality classics. If you are an Arts & Crafts fan, this book is required reading.

Start With the Sides

Most of the work on this project is in the two assemblies that make up the sides of the cabinet. And the heart of these side assemblies is the side panels.

These two panels have a tongue on the two long edges that are glued into a groove in the legs.

Dados in the panels hold the shelves in place. And the rails are tenoned into mortises in the legs. Finally, the top is screwed down to the cabinet using cleats.

The first task is to prepare the side panels to be glued between the legs. I used a traditional tongue-and-groove joint. It’s more elaborate than simply gluing the panel between the legs without joinery. However, it also guarantees you will have no visible gap between the legs and panel.

If you want to do things in this more traditional way, begin by milling a 1/2"-wide, 3/8"-deep and 31 3/4"-long stopped groove on the leg in the location shown in the diagram. Square out the groove where it stops using a chisel.

Now cut a matching tongue on the two long edges of your panel. You want the fit to be as near perfect as possible.

To keep things neat, I used a backsaw to cut a small shoulder on the bottom corners of the panel



There are a variety of ways to cut the groove in the legs: A router table and a plow plane come to mind. I prefer to use a straight bit in a router with an edge guide. This allows me to see my cut at all times.



Cut the tongues on the edges of the side panels using a dado stack in your table saw (plus a sacrificial fence). You also could use a rabbeting bit in your router table.



When your grooves and tongues are complete, they should fit snugly as shown. If you’re not up to this task, you could simply glue the panel to the legs without any joinery. Just make sure you keep everything lined up so you’re certain you’ll achieve a tight joint.

WHO WAS HARVEY ELLIS?

Though Harvey Ellis worked for Gustav Stickley for only about a year until he died in 1904, Ellis’s work left an indelible impression on Stickley’s furniture. Chunky forms became lighter. Rails became curved. Legs became tapered on the sides. And – perhaps most significantly – some furniture became inlaid.

Before Ellis’s stint with Stickley, Ellis led an itinerant life as an avant-garde painter, graphic designer, draftsman and sometimes architect, according to scholars. Born in Rochester, N.Y., in 1852, Ellis displayed an early knack for art as a child. His father decided he needed more discipline and sent him to West Point in 1871, according to the Harvey Ellis papers at the University of Rochester. Ellis was discharged from the military school for “tardiness, personal untidiness and gross neglect in his French assignments,” according to the papers. There also were rumors of an affair with an actress.

Ellis went to New York to study art at the National Academy of Design, but he ended up as an architectural draftsman for Arthur Gilman instead. He returned to Rochester in 1877 and set up an architectural office with his brother, and together they designed many public buildings. After seven years or so Ellis left the firm and designed houses and public structures for cities across the Midwest. He rejoined his brother’s firm in 1894 and also started designing interiors and becoming interested in the Arts & Crafts movement.

After separating from his wife, Ellis joined the staff of Stickley’s magazine, *The Craftsman*, and began designing furniture and writing stories for the influential publication. He died in January 1904 at the age of 52, in part due to acute alcoholism, according to the university papers.

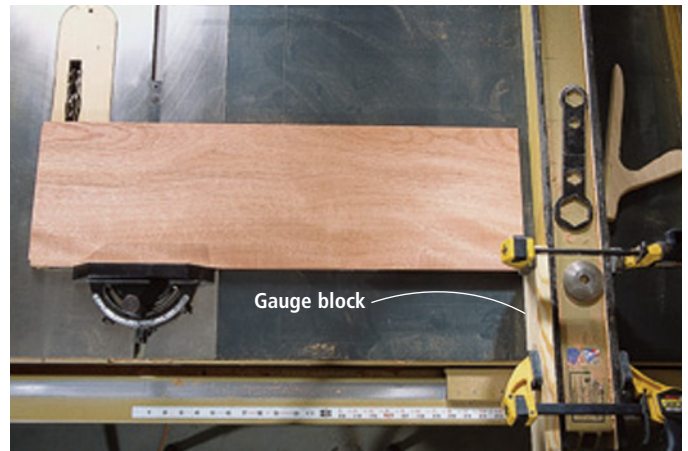

Cut the dados in the side panels using this setup on your table saw or a straight edge and a hand-held router. The gauge block on the right of the blade keeps the panel from getting caught between the fence and the blade.



You'll need to notch the bottom of the side panel to fit in the leg groove. A backsaw makes quick work of this simple operation (above). Clean up the cut with a sharp chisel and you're ready to move on (right).

that conceals where the groove ends (see the photo above).

Before you can glue the side panel between the legs, you need to cut the $\frac{1}{4}$ "-deep by $\frac{3}{4}$ "-wide dados that hold the shelves. Use the diagrams at right to lay out the locations of the dados, then cut them using your dado stack as shown in the photo.

If all this seems complicated, the sides can be simplified. Make your side panels 9" wide instead of $9\frac{3}{4}$ " and don't cut the tongues and grooves. Cut the dados for the shelves and then simply glue the panels between the legs.

The long-grain joint between the side panel and legs is stronger than the wood itself – you'll just have to be careful about lining everything up and making sure your stock is milled perfectly to avoid any gaps between the legs and the side panels.

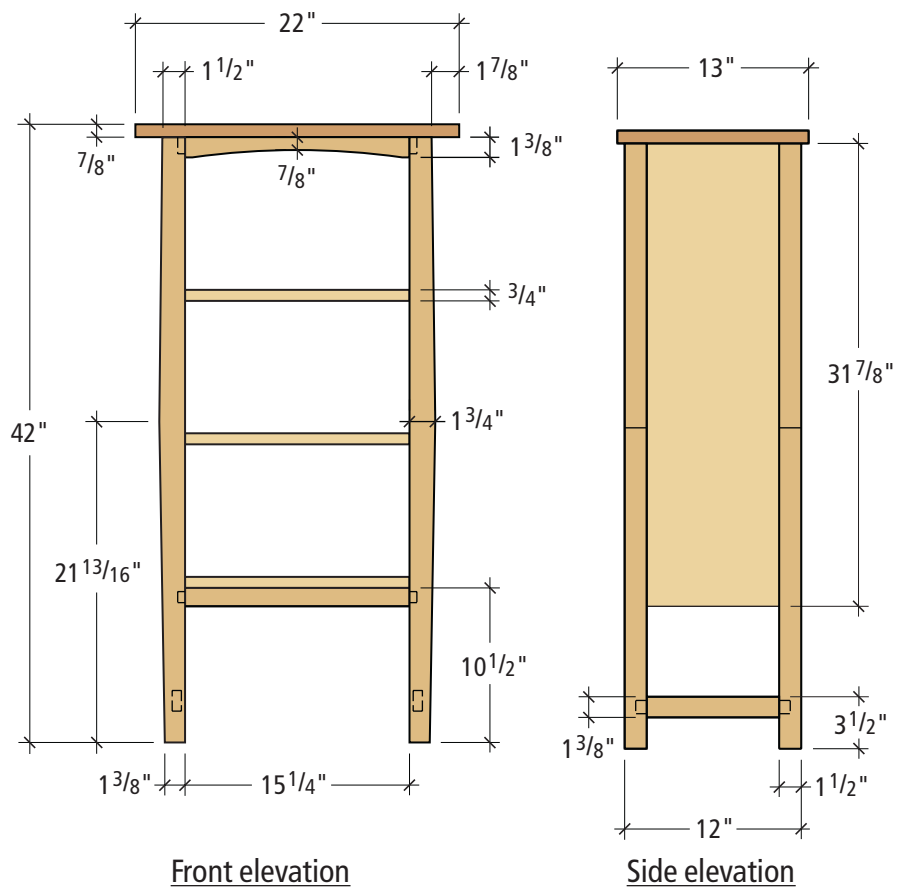



GUSTAV STICKLEY MAGAZINE CABINET

NO.	ITEM	DIMENSIONS (INCHES)			MATERIAL	COMMENTS
		T	W	L		
4	Legs	1½	1¾	41⅛	Mahogany	
2	Side stretchers	⅝	1⅜	10½	Mahogany	¾" TBE
2	Side panels	¾	9¾	31⅞	Mahogany	⅜" tongue, 2 edges
2	Bottom rails	¾	1¼	16¾	Mahogany	¾" TBE
2	Arched top rails	¾	1⅜	16¾	Mahogany	¾" TBE
3	Shelves	¾	11¾	15¾	Mahogany	
1	Top	⅞	13	22	Mahogany	
2	Cleats	½	½	8	Mahogany	Attach top to sides

KEY: TBE = tenon on both ends

To prevent tearout where the dado stack exits the side panel, put down a couple pieces of masking tape to support the wood fibers. This really works.

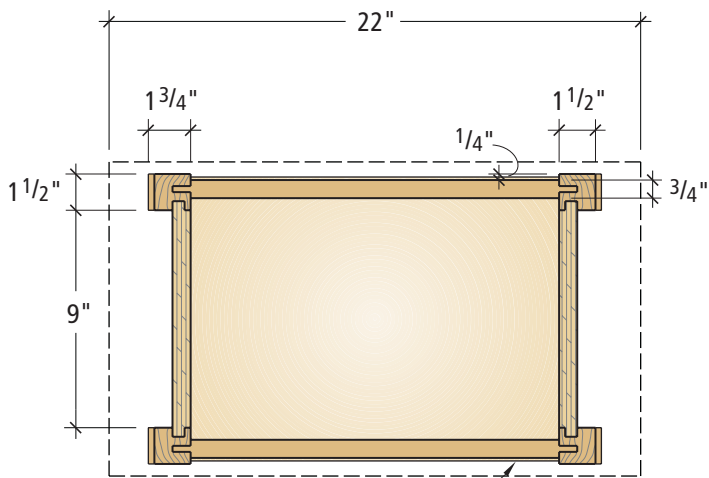

Plan section through rails

Front edge of shelf is 1/8" past rail,
1/8" behind front of leg

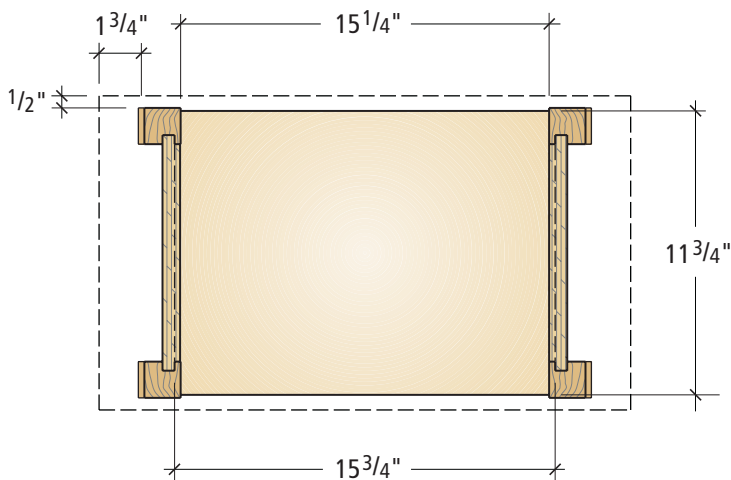

Plan section above shelf

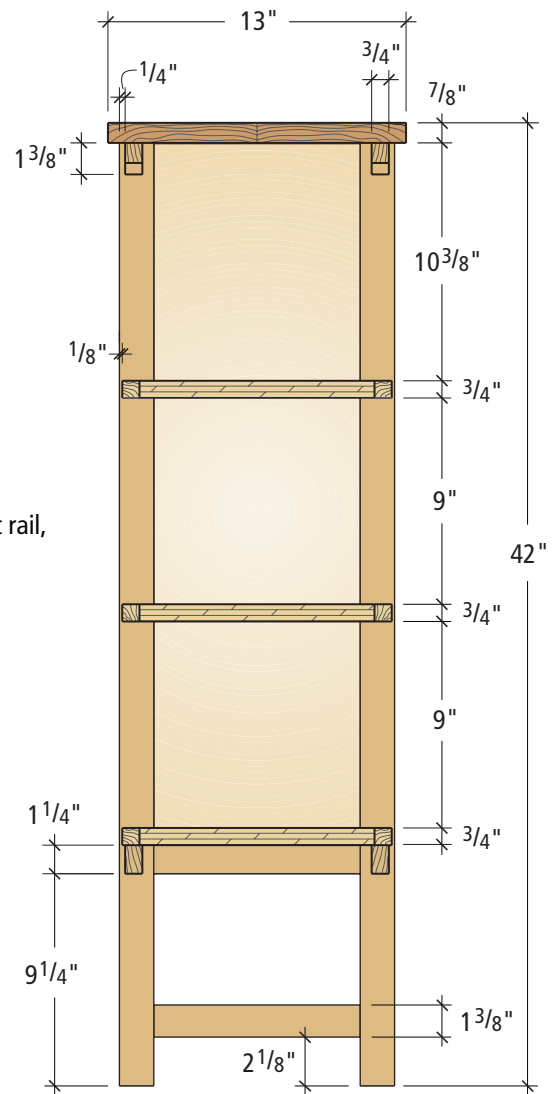

Side section

Illustrations by Robert W. Lang

Sure, you could set up your router table or table saw to cut the notches in the shelves. But a sharp backsaw works just as well.



Before you glue anything up, however, you're going to want to first cut the mortises in the legs. So set your parts aside and fit the shelves in their dados.

The Shelves are Simple

Cut the shelves to finished size and mark out the notch that needs to be cut in the corner of each shelf. This notch allows the shelves to wrap around the legs. You can rig up some fancy setup with your router table to do this, but I prefer using a backsaw for such a simple task (see the photo at left).

Now fit your shelves in the dados and make any adjustments

necessary using a block plane or chisel. When everything is fitting nice and snug, it's time to cut the mortise-and-tenon joints that hold everything together.

I usually cut my tenons using a dado stack or a tenon saw. When it comes to mortises, I usually choose to drill them out on the drill press or fire up the hollow-chisel mortising machine.

However, for this project, I put the new Leigh Frame Mortise and Tenon Jig through its paces. It's healthy to be skeptical of any jig that costs as much as a table saw, but this jig is one special animal. See the story titled "The

NEWEST JIG FROM LEIGH MAKES PERFECT MORTISES AND TENONS



With the assistance of your plunge router, you can cut almost any mortise-and-tenon joint with this new jig from Leigh Industries.

Though the Leigh Frame Mortise and Tenon jig looks complex, it will feel instantly familiar if you've ever used your router for pattern cutting.

The jig uses snap-in templates that guide a plunge router as it cuts both tenons and mortises. You merely select the size tenon you want to cut and snap that template in place in the jig.

The Frame Mortise and Tenon Jig – like all jigs from Leigh (leighjigs.com) – is an impressive and well-thought-out piece of engineering. As I started using the jig, every single question or objection I had was addressed in the manual and thoughtful design of the jig.

For example, most people would wonder how

Position the tenon stock in the jig and set your depth of cut (which will be the length of your tenon). Then plunge your router. A pin on the router's subbase (included with the jig) follows the outside edge of the template. Your tenon is done.

To cut the mortise, position the stock in the jig and place the pin into a slot on the inside of the same template you used for the tenon. Plunge your router and make your mortise. If the joint is too loose or too tight, you merely need to turn a small dial on the subbase to adjust the cut in .001" increments. Simple.

well this jig clamps long workpieces in place; some face-frame stiles can be 5' long after all. Well let me tell you the clamps on this jig are impressive. They engage with only fingertip pressure, but exert so much force we couldn't deflect long pieces, even when we tried leaning on them harder than we should have.

Setting up the jig for the first time takes a couple hours. The manual (a paragon of clarity) walks you through the process of installing your plunge router (most models will work easily) and getting it locked down to the subbase. Once this is set up, however, you can easily remove your plunge router and return it to the jig in a matter of moments. This is a one-time thing. After your router is in place, you're ready to make test cuts.



The templates snap in and out of place with fingertip pressure. Pick your tenon size and pop it in the jig.

Newest Jig from Leigh” for more information on this precise joint-cutting system.

Details Lighten the Load

With the tenons and mortises milled, it’s time to make a few cuts that visually will slim this chunky box a bit.

The first order of business is cutting the curve on the top rails. Mark the curve using the diagrams and a flexible piece of scrap wood. Cut the curve using a coping saw and clean up the saw marks using a spokeshave or sandpaper.

Now cut the tapers on the legs using the diagrams as a guide. I

Now fit your parts together and tune up the notches in the shelves with a sharp chisel so you get a tight fit between the sides and the shelves.



Center the table over your tenon using the slide-out window. Lock the table in place and put the router up on the jig.



You can connect dust collection to the back of the jig, which I recommend. It doesn't get all the chips, but it cuts down significantly on the mess.

tenons from bottoming out in the mortise). Lift the router subbase and place the pin on the inside track of the template. Plunge and make a few holes first. Then move the jig back and forth to clean out the walls of the mortise.

The jig is capable of cutting just about any mortise-and-tenon joint you can think of, including double, triple and angled tenons. Slip-joints are also a breeze. To be sure, there are less expensive ways to cut this traditional joint. The jig costs about \$700 and comes with one template set and a $\frac{5}{16}$ " cutter. However I know of no better or faster way to cut mortises and tenons, and it's worth a close look for your shop.

— Christopher Schwarz

Select the size tenon you want based on your project's design. By changing which diameter cutter you use, tenons of almost any thickness are possible (a chart in the manual guides you through this). Snap the template into the jig.

Now mark the center of your tenon on the end of your workpiece. Then you center the table over the tenon using a little slide-out window. It works kind of like a bomb sight. (One side note: Though you think that someday you'll forget to retract this plastic sight and rout it to pieces, that's actually impossible. The jig is designed to push it out of the way if you forget to.) The manual shows you how to set up a stop (included with the jig) that positions your tenons in the same place every time, without using the sight. That said, after a week of using the jig, I found I got better results by marking the center of each tenon and adjusting the table slightly (usually

less than $\frac{1}{64}$ " each time I made a cut. It takes about three seconds to do. The variability, I suspect, comes from the fact that wood can warp a bit as it's ripped to width.

Set your plunge router for the depth of cut you want ($\frac{3}{4}$ " in this case). Plunge and then circle the jig's pin around the template. Cut all the tenons for your project this way.

Mortising uses almost the same procedure. Mark the center of your mortise, clamp the piece in your jig and center the table over the cut.

Turn the turret depth stop on your router so it makes a slightly deeper cut (this keeps your

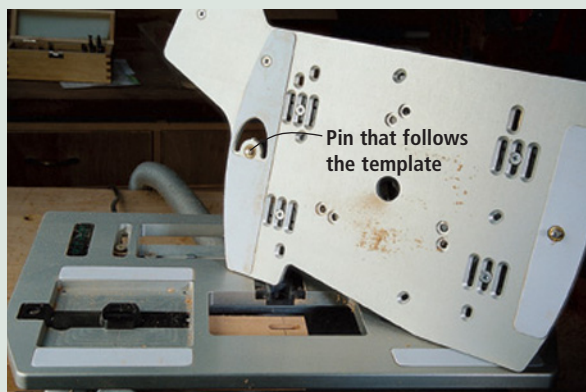

Mortises are just as easy as tenons. Here you can see the pin on the subbase that rides the outside of the template for tenons and the inside for mortises.



A spokeshave cleans up your saw cuts on the top rails quickly. After working with the fancy Leigh jig, it's a relief to pick up a tool that's simpler than I am.

cut the tapers using my band saw and cleaned up the cuts with a smoothing plane. Keep the off-cuts because they are useful when gluing the case together at the end of the project.

Now sand or plane down all your parts and glue up the side assemblies. In order to attach the top, screw the cleats to the top edge of your side assemblies and bore a couple holes through the cleats. Break all the edges of your parts with 120-grit sandpaper.

Now comes an important decision. You can go ahead and assemble the case and then finish it. Or you can tape off the joints, finish the individual parts and then assemble the case. I took the latter course.

I kept the finish simple on this piece. I wiped on Minwax's "red mahogany 225" stain on all the parts. This stain is available at most home-center stores; 8 ounces will cost you less than \$3. Allow the stain to dry overnight.

The next day, apply a few coats of your film finish of choice. I sprayed M.L. Campbell's Magnalac precatalyzed lacquer (satin sheen) using a HVLP spray system. Sand

SUPPLIES

Frame Mortise and Tenon Jig
Leigh Industries Ltd.
P.O. Box 357
104-1585 Broadway St.
Port Coquitlam, BC, Canada
V3C 4K6
800-663-8932
leighjigs.com

Lie-Nielsen Small
Bronze Spokeshave
Lie-Nielsen Toolworks
P.O. Box 9
Warren, ME 04864-0009
800-327-2520
lie-nielsen.com

between the second and third coats with 320-grit steared sandpaper. Remove the tape from the tenons and then glue up the individual parts of the cabinet. Use the falloff pieces from cutting the leg tapers to clamp the lower part of the case squarely.

If you haven't figured it out yet, magazine cabinets aren't much good for storing modern magazines (unless you stacked them flat). But they do make handy bookshelves – especially for antique volumes.

Once I set the cabinet in place next to my fireplace and loaded it up with books, I took a second look at the picture of the original in the 1910 Gustav Stickley catalog. Someone in his art department should have been fired for butchering that photo. This is a nice piece. **PW**

Most people don't notice the tapers on the legs. (My wife didn't, and she has a sharp enough eye to always find my car keys.) The tapers are critical, however. You definitely would notice their absence.



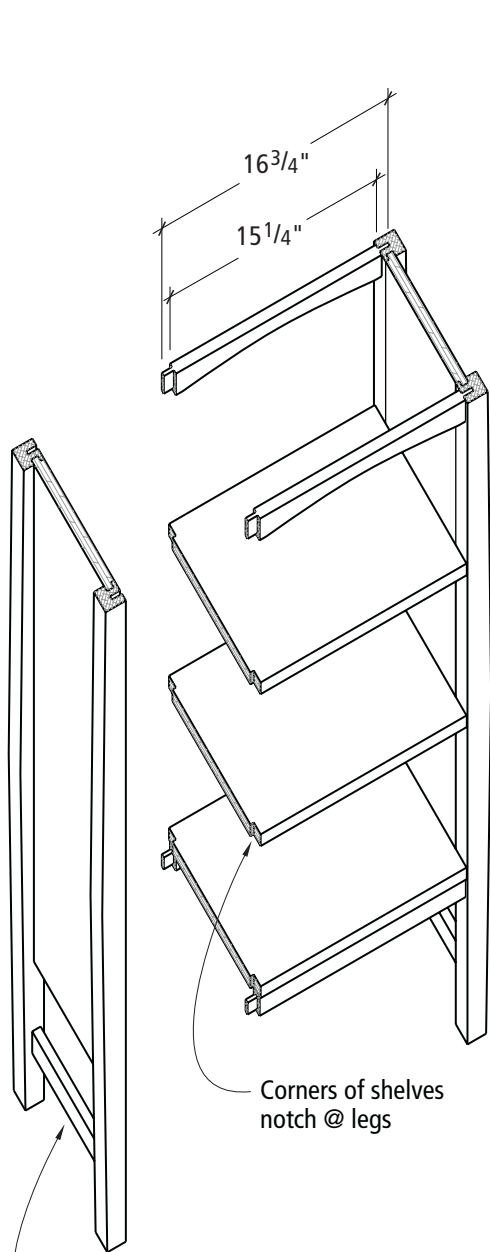

Corners of shelves notch @ legs

Lower stretcher is $\frac{5}{8}$ " thick

Detail of shelf notches

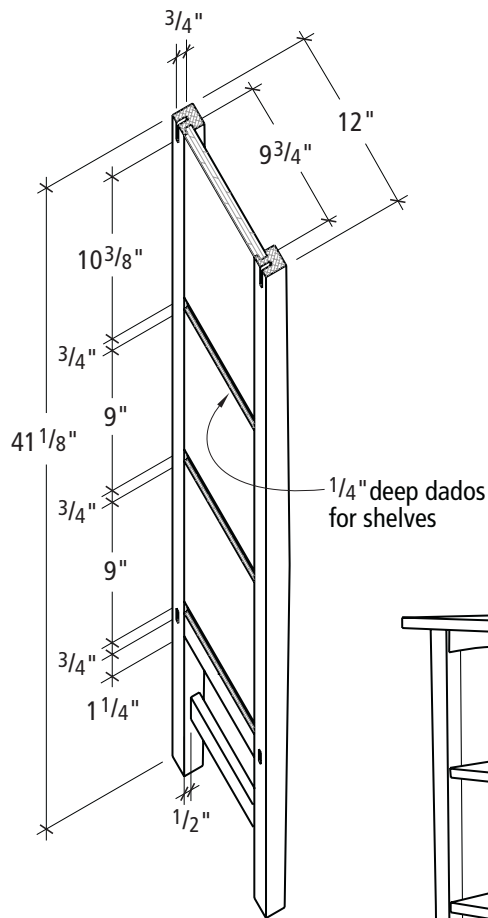

Shelf locations

The illustrations in "More Shop Drawings for Craftsman Furniture" are black and white, like the drawings shown here.

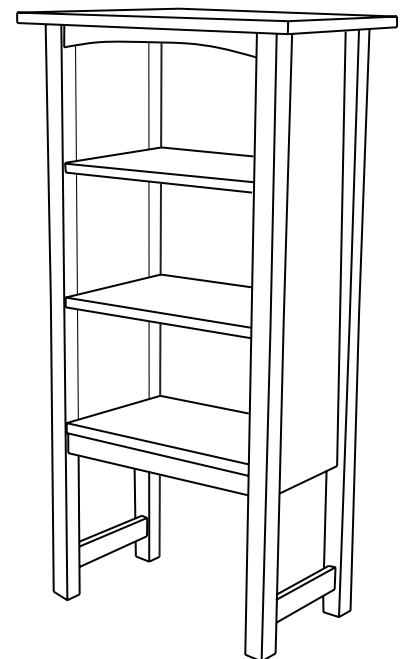

Finished stand

"MORE SHOP DRAWINGS FOR CRAFTSMAN FURNITURE"

I've been collecting and building Arts & Crafts furniture for more than a decade now, and I've been waiting for this book (and its predecessor "Shop Drawings for Craftsman Furniture") for about that long. In fact, it's a wonder that no one has written these books until now.

Author Robert W. Lang essentially presents you with the keys to the castle: 30 shop drawings of some of the most well-designed

Craftsman furniture from this important artistic and cultural movement. You get measured drawings of the plan, profile and elevation (usually called a three-view in design circles) and at least a couple exploded 3D drawings (called isometrics). Plus there's a cut list. Intermediate woodworkers will be able to go straight to work. For the beginners, there's a section in the front of each book that explains

basic construction techniques. However, first-timers would do well to get a couple simpler projects under their belts first.

For more details on these books, visit the publisher's web site: cambiumbooks.com. You can order these books direct from the publisher by calling 800-238-7724. Each book costs \$22.95 plus shipping.

— Christopher Schwarz



Heirloom Photo Album

Your most precious family photos will be all the more memorable when bound in a custom-made presentation album.



Photos by Al Parrish

Given the current craze for scrapbooking, I thought it high time we woodworkers weigh in with our own version of what a memorable photo album should look like.

And if you are tempted to rip out these magazine pages before your spouse sees them and places an order for say, a dozen or so, fear not. This truly is an easy project. It could even be simpler than what you see here if you skip the re-sawing and bookmatching of the 1/4"-thick front and back covers.

In fact, if you were making five or six at a time, you could probably spend no more than a half hour on each one. Or, you could go in the other direction and make it more complicated with inlay or chip carving on the front.

There could, in fact, be many variations on this project. You could easily alter the size of the covers for smaller photo album sheets, you could set it up with blank pages for use as a personal journal, or documents from your family tree research.

No matter what direction your version of this project takes, two simple elements will make it all possible: the post binding screws that fix the covers and pages together, and the small-scale continuous hinge that allows the covers to open, making them truly functional. The hinges and post binding screws can be ordered

through the Lee Valley woodworking catalog.

Getting Started

A trip to an art or office-supply store is the first step. Select the photo page size you want to work with. Some pages simply are plain sheets that are inserted in clear plastic sheet protectors. The protectors, in turn, are usually punched for use in a three-ring binder. The sheets I used were hole punched for post binding and "hinged," meaning each sheet was made to fold at a given place along the edge where it would be bound into the album.

I selected a sheet size that was 12" x 12". Next I ordered my post binding screws and hinge from Lee Valley. The screws, called "Chicago Bolts" in the catalog, come in various lengths, with each length allowing for a 1/4" adjustment. The brass hinge comes in a 3" length and is easily cut.

The page size and hinge gave me dimensions I could start to work with. The wood covers' finished size is 1/4" x 12 1/2" square. This allows 1/4" for the cover to overlap top and bottom. The bound side has 1/8" overlap, leaving 3/8" for the open side. When I cut the pieces I made the width 12 5/8". This allowed a table saw cut to separate the binding strip from the cover piece. The cover thickness was 1/4", which is perfect for the hinge leaf.

A Word About Wood Choice

My album covers are made using feather-figured walnut that was resawn and bookmatched. It came from a tree in my neighborhood that was taken down and sawn into lumber about three years ago. Although it's been air drying all

this time I was nervous as a cat about my pieces warping after re-sawing and glue up. Highly figured wood often has a mind of its own. I know that walnut is a relatively stable wood, like mahogany, but I kept my pieces on a flat surface with a weight on top until I was able to put a finish on them. Even at the thin 1/4" dimension, I was lucky and both pieces have remained perfectly flat.

The point of all this is to remind you to be cautious about your wood selection and handling. Try to use a stable species. A narrower album would be less risky.

Hardware Installation and Finishing

I followed the hole patterns for the post binding screws that were already in the album sheets. Allowing for the top and bottom overhang, my hole center for the screws was 2 9/16" from the top and bottom. From the binding edge, I marked a hole center of 1/2".

The posts required a 1/4" hole with a 1/2"-diameter counterbore to recess the flat heads of the screws. I used a Forstner bit for drilling in my drill press. It is necessary to drill the front and back binding strip exactly alike.

At this point I progressively sanded to 220 grit, rounded the outside corners to a 3/16" radius, and heavily eased the edges, except for the edges where the hinge would be installed.

The finish may be a bit more complicated than you are accustomed to, but the fantastic figure in the walnut demanded as good a finish as I know how. And it was worth each step. Because walnut is an open-pore wood, I filled the grain using paste wood filler. I added oil-based walnut stain to the filler to color the filler and the wood. After applying the filler, I allowed it to dry for 24 hours.

For a clear top coat I used a

by Steve Shanesy

Comments or questions? Contact Steve at 513-531-2690 ext. 1238 or steve.shanesy@fwpubs.com.

lacquer that comes in an aerosol spray can. The product is the best lacquer in a can I've ever used. It's called Master's Magic and is available from The Woodturners Catalog. A can of sanding sealer and satin finish lacquer are required, and the product should be used only in a well-ventilated area free of open flames (including pilot lights on water heaters or furnaces) or potential sparks.

After applying the sanding sealer, carefully sand with 360-grit paper, being especially careful near the edges. The idea is to lightly sand down any dust particles or bubbles that may have formed but not to sand into the stain color below the sealer. After sanding the sealer, spray two top coats with the satin finish. Allow the finish to cure overnight, even though it will be dry to the touch in 15 minutes.

I used a pair of snips to cut the hinges to $12\frac{1}{8}$ " long. Cut the hinge at one of the leaf joints. The hinges are attached using flat-head brads that you should

order along with the hinges. Predrill the holes for the brads into the edge of the wood leaving about $\frac{1}{4}$ " of the brad length not drilled. Predrilling should ensure nothing pokes through the face of the cover.

Insert the post part of the post binding screws and fill your photo page inserts. I found that it was necessary to slightly enlarge the holes in the sheets with an ordinary paper punch. When done, lay the other cover over the post and then insert the screw.

If you are considering leaving the album on a coffee tabletop, or if you just want to protect the back cover from scratches, put a felt bumper pad in each corner of the back cover.

As a photo album or scrap book, this project makes an extra special gift for an extra special occasion. Is there a family wedding in your future? **PW**



Brass miniature continuous hinges are a cinch to cut with a pair of metal shears. Make your cut at the joint where two hinge leaves meet nearest your ideal length.



An ordinary paper hole punch enlarged the holes that were pre-punched by the manufacturer of the photo album sheets.

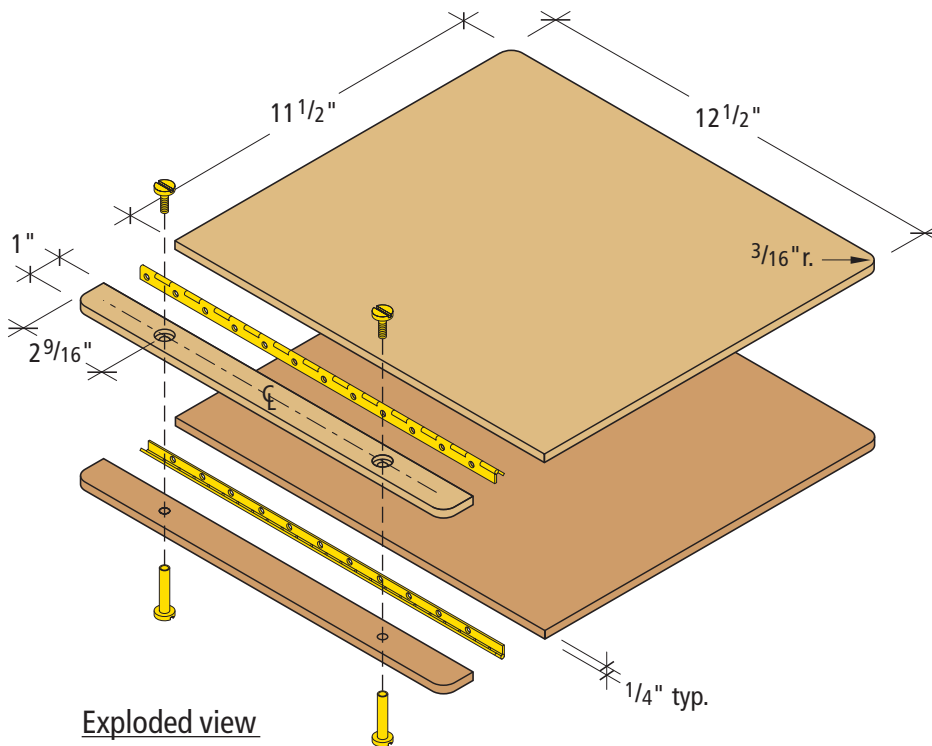

Exploded view

SOURCES

Lee Valley Tools
800-871-8158
leevalley.com

Brass piano hinge,
12mm x 800mm,
#00D50.12, \$4.30

Brass escutcheon pins,
flat head, #00D41.02 \$1.18

Chicago bolts, brass,
30 - 36mm, 4 pack,
#00K40.05, \$2.80

Craft Supplies USA
800-551-8876
woodturnerscatalog.com

Masters Magic Lacquer
Sanding Sealer, aerosol can,
#299-0100, \$8.99

Masters Magic Satin Spray
Lacquer, aerosol can,
#299-0001, \$8.99

BEFORE the ER

If you injure yourself seriously, here's a practical guide to what to do (quickly) before you trek to the hospital.

You've done something dumb or something has gone wrong in the shop. Now the question going through your head is, "Should I go to the ER with this?" As my father used to say, "If you're asking the question, that's the answer." So what should you do now? A few basic rules and some common sense can make you more comfortable and help ensure the best outcome.

First, the easy stuff:

Life-threatening Injuries

This means anything that could kill you, such as poisoning, electrocution, chest pain, difficulty breathing or arterial bleeding (blood isn't just running out, it's

squirting out – with your pulse – and the squirts are jumping over your finger onto the floor).

Decide if the injury is life- or limb-threatening. If it is, call 911, keep quiet and wait for rescue. Lie down. That way if you do faint, you won't injure yourself further by falling. Apply gauze and direct pressure to any bleeding. Be advised that if you use a tourniquet to stop the bleeding, you may lose the extremity.

Assuming your injury isn't life-threatening but is more than you can fix with duct tape (no kidding), don't panic. It's often said in medicine that the first thing to do in an emergency is to take your own pulse, and there's truth to it.

Something in Your Eye

If it really hurts it will probably be chemical, organic (wood, etc.), metallic or glass. The worst is chemical, with alkali worse than acid, followed closely by organic (some plants also contain alkaloids that can be very caustic). Whatever it was, first rinse the eye out with lots of clean, clear water, then have someone drive you to the nearest ER (do not drive; you have no depth perception with only one eye). If it was metal or glass, keep the eye closed to minimize more damage.

Puncture Wounds

This is a hole deeper than it is wide. If you've just shot a nail through an extremity, don't pull it out. The nail may be keeping a blood vessel from bleeding. Gently wrap the area and get help. If you've stepped on a nail and pulled it out, still get to the doctor anyway. There is an 80-percent chance some of your shoe went into your foot and will need to be removed.

Bleeding

Again, rinse and apply gauze and direct pressure to any open cut. A cut through the skin that's deep enough to allow separation of the cut edges will require stitches.

Fractures

Fractures of an extremity can be stabilized by gently rolling a good-quality magazine around it and tying or taping it in place. Be sure to check for a pulse on the extremity before and after stabilization. If any bone is showing, don't touch it, and call 911.

Burns

Immerse the wound in cold water (it will still be burned, but will hurt less). If there's a blister, don't break it. A blister is still intact skin and less prone to infection. If the area is white or black and does not hurt, it's a third-degree burn and you should call 911.

Amputated Limb

If you've cut off a finger with your table saw, apply gauze and pressure to the wound. Call 911, then wrap the amputated part in a wet cloth, put that in a sealed plastic bag and onto ice. Then someone should drive you to the ER.

But no matter what else don't panic. If you stop and think before you act, most emergencies can be stabilized until evaluated by the professionals. **PW**

Dr. D. Michael Jervis practiced family medicine for three years and emergency medicine for three years in Jacksonville, Florida, where he also taught courses in advanced cardiac life support and treatment of shock. He currently works as a staff physician in the VA Emergency Department in Lake City, Florida.





Classic Wardrobe

Large cabinets are easier to build (and to move) when you construct smaller cabinets and attach them using waist moulding.

Although this traditional-style wardrobe looks like it was plucked straight out of the 19th century, it has many uses in today's more modern homes. I built this wardrobe for my bedroom. I plan to store folded sweaters and shirts in the top case, although you could make the cabinet 24" to 25" deep and add a rod to hang your clothes in the top case. Or, you could easily transform this project into a home entertainment center.

The top case can hold TVs as large as 36". You can then store media equipment on adjustable shelves installed in the top case, and use the bottom drawers to store DVDs and video game controllers. That's the beauty of a project like this – you can easily adapt the plans to create a storage unit that fits your home.

I build all of my cabinets the same way. If you've ever built one of my cabinets before, you know the drill is pretty simple no matter how challenging the finished product looks.

All of my cabinets are built using solid lumber, no plywood. The cabinets have face-frame fronts with raised-panel doors that are held together with mortise-and-tenon joints. The backs are shiplapped. The drawers are dovetailed together, and the moulding requires a few basic cuts. The base is incorporated into the lower cabinet. I gave up making a separate base assembly years ago. The scrollwork on the base is easy using our scaled template.

Frame (as Always) First

Start with the face frames for both the top and bottom cases. I use mortise-and-tenon joints to hold my face frames together. Rip your stock $\frac{1}{16}$ " wider than shown in the cutting list. This gives you some room to play when you trim your face frame flush to the case.

Now cut the tenons. Center each tenon on the end of each rail. Set up a dado stack in your table saw to cut 1"-long x $\frac{3}{8}$ "-thick tenons. For the edge shoulders of the tenons, I recommend



Some people like to make the beading part of their face frame. I find that it's easier to cut a $\frac{5}{16}$ "-wide piece of bead moulding to size and then attach it to the frame. Here you can see I'm attaching my face-frame bead with a brad nailer.

by Troy Sexton

Troy Sexton designs and builds custom furniture in Sunbury, Ohio, for his company, Sexton Classic American Furniture. Troy is a contributing editor for Popular Woodworking.



This is what the face-frame bead looks like before I nail it in place. No one would ever know that I made the beading separate from the frame.

you make them at least $\frac{3}{8}$ ". Use your tenons to lay out the mortises on the stiles. Now chop out the mortises with your mortiser, going about $\frac{1}{16}$ " deeper than the length of your tenons to avoid them bottoming out.

It's time to assemble the frames. Spread a little glue into each mortise (don't overdo it) and clamp the frames up. Be sure to check for squareness by measuring from corner to corner.

While the glue in your face frame sets, turn your attention to

the applied beading on the inside edge of the face frame. The bead moulding is made using a beading bit mounted in my router table and $\frac{5}{16}$ " x $\frac{3}{4}$ " stock. Miter the corners of the moulding. Then glue and nail it in place as shown in the photo at left.

Make a Case

With the face frame completed, it's time to build the top and bottom cases. Both cases, although large, are built using simple dado and rabbet joints. The overall di-

mension of the bottom case is $\frac{3}{4}$ " deeper and $1\frac{1}{2}$ " wider than the top case. This gives the top case something to sit on with room for moulding.

First, cut all your lumber to size and glue up the panels for the sides, tops and bottoms. Grab the top and bottom case's side pieces and head to the table saw.

Start with the two sides of the top case. A rabbet joint cut at the top of the top case will keep the top flush with the top case sides. So your first step is to cut a $\frac{1}{4}$ " x

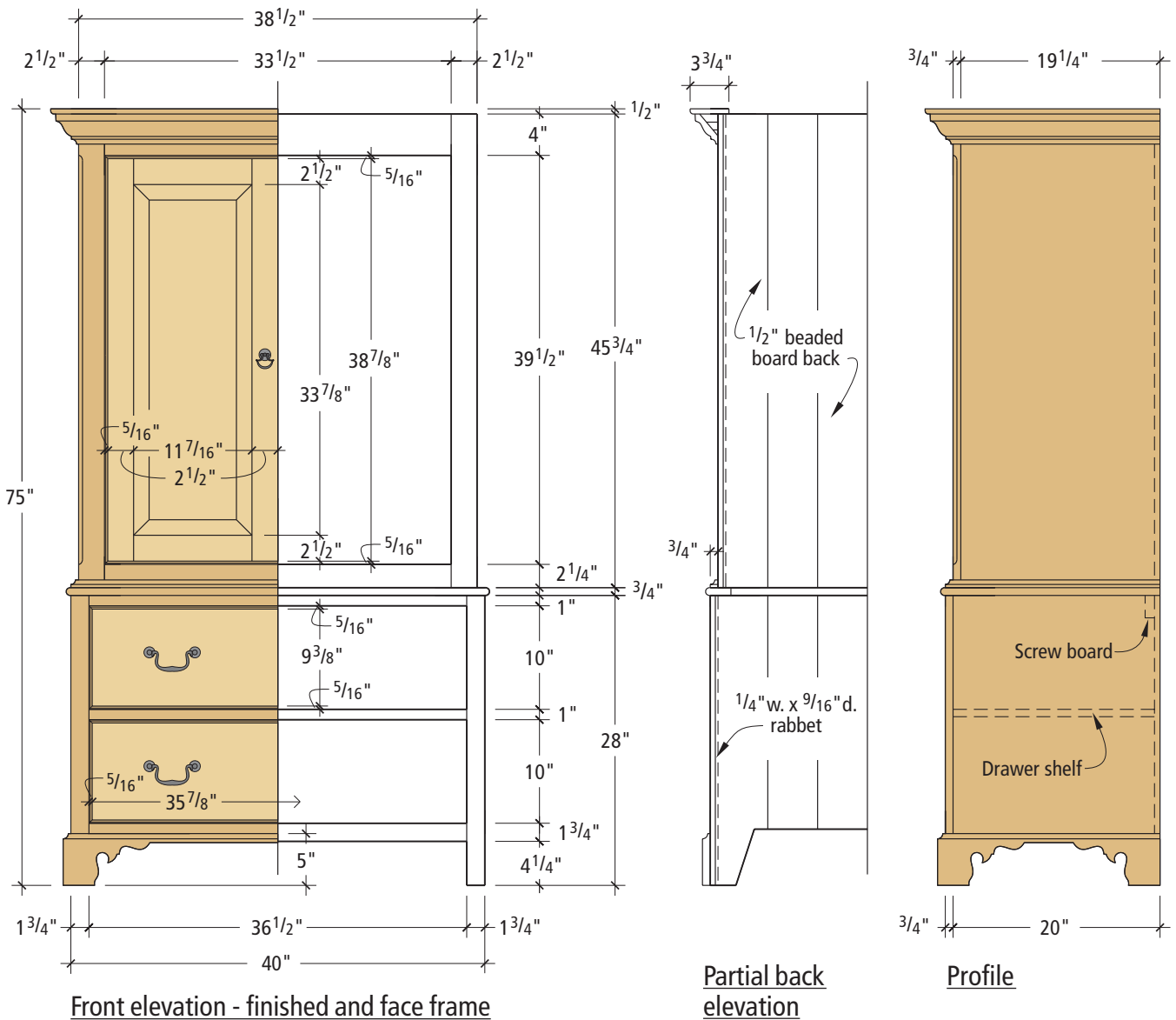

$\frac{3}{4}$ " rabbet at the top of each side. Next, you need to cut a dado joint to hold the bottom of the top case. The bottom is located 2" up from the bottom edge of the sides. By doing this, the bottom will also act as a door stop. Your dados should be $\frac{1}{4}$ " deep by $\frac{3}{4}$ " wide.

Now grab your drill and bore holes in the top case side's for the adjustable shelves.

It's time to move to the bottom case sides. Some people build web frames to guide their drawers. I think it's a lot simpler and easier to use solid shelves to divide the drawer spaces.

Your first shelf is located 11" down from the top of the case side; the second shelf is located 22" down from the top of the case side. Each of these shelves fit in $\frac{1}{4}$ "-deep by $\frac{3}{4}$ "-wide dados. Go ahead and cut these dados.

Next, cut a $\frac{1}{4}$ "-deep by $\frac{9}{16}$ "-wide rabbet on the inside edges of the side pieces for both cases to accept the back.

Finish sand the interior parts. Assemble both the top and bottom cases using glue and a finish nailer. Make sure everything is square by measuring from corner to corner of the case.

Before you attach the face frames to the case, you need to temporarily install the back. I used $\frac{1}{2}$ "-thick hardwood cut to random widths to build my beaded shiplapped back. Cut $\frac{1}{4}$ " x $\frac{1}{2}$ " rabbets on the slat sides. Attach the back with screws and double check for squareness.

Once your cases are assembled, lay each case on its back, and glue, nail and clamp the face frames to the top and bottom cases. When the glue is dry, trim the face frame flush to the cabinet sides using a flush-cutting bit chucked into your router, as shown in the photo above.

Before you move on to the doors, add the screw board to the

Building the face frame first allows you to trim the frame to fit the case, once the case is assembled.



CLASSIC WARDROBE

NO.	ITEM	DIMENSIONS (INCHES)			MATERIAL	COMMENTS	
		T	W	L			
Top Case Pieces							
<input type="checkbox"/>	2	Upper face-frame stiles	$\frac{3}{4}$	$2\frac{1}{2}$	$45\frac{3}{4}$	Curly maple	
<input type="checkbox"/>	1	Upper face-frame top rail	$\frac{3}{4}$	4	$35\frac{1}{2}$	Curly maple	1" TBE
<input type="checkbox"/>	1	Upper face-frame bottom rail	$\frac{3}{4}$	$2\frac{1}{4}$	$35\frac{1}{2}$	Curly maple	1" TBE
<input type="checkbox"/>	2	Upper sides	$\frac{3}{4}$	$19\frac{1}{4}$	$45\frac{3}{4}$	Curly maple	
<input type="checkbox"/>	4	Door panel frame stiles	$\frac{3}{4}$	$2\frac{1}{2}$	$38\frac{7}{8}$	Curly maple	
<input type="checkbox"/>	4	Door panel frame rails	$\frac{3}{4}$	$2\frac{1}{2}$	$12\frac{5}{16}$ *	Curly maple	
<input type="checkbox"/>	2	Door panels	$\frac{5}{8}$	$12\frac{1}{16}$	$34\frac{1}{2}$	Curly maple	
<input type="checkbox"/>	2	Top, bottom	$\frac{3}{4}$	$18\frac{11}{16}$	$37\frac{1}{2}$	Poplar	
<input type="checkbox"/>	4	Upper adjustable shelves	$\frac{3}{4}$	$18\frac{1}{2}$	$36\frac{3}{4}$	Poplar	
Bottom Case Pieces							
<input type="checkbox"/>	2	Lower face-frame stiles	$\frac{3}{4}$	$1\frac{3}{4}$	28	Curly maple	
<input type="checkbox"/>	1	Lower face-frame bottom rail	$\frac{3}{4}$	$1\frac{3}{4}$	$38\frac{1}{2}$	Curly maple	1" TBE
<input type="checkbox"/>	2	Lower face-frame top & mid-rail	$\frac{3}{4}$	1	$38\frac{1}{2}$	Curly maple	1" TBE
<input type="checkbox"/>	2	Lower sides	$\frac{3}{4}$	20	28	Curly maple	
<input type="checkbox"/>	2	Drawer fronts	$\frac{3}{4}$	$9\frac{1}{4}$	$35\frac{7}{8}$	Curly maple	
<input type="checkbox"/>	4	Drawer sides	$\frac{1}{2}$	$9\frac{1}{4}$	$19\frac{1}{2}$	Poplar	
<input type="checkbox"/>	2	Drawer backs	$\frac{1}{2}$	$8\frac{7}{16}$	$35\frac{7}{8}$	Poplar	
<input type="checkbox"/>	2	Drawer bottoms	$\frac{1}{2}$	$19\frac{11}{16}$	$35\frac{1}{8}$	Poplar	
<input type="checkbox"/>	2	Lower shelves	$\frac{3}{4}$	$19\frac{7}{16}$	39	Poplar	
<input type="checkbox"/>	1	Lower screw board	$\frac{3}{4}$	$1\frac{1}{2}$	$38\frac{1}{2}$	Poplar	
<input type="checkbox"/>	4	Drawer runners	$\frac{3}{4}$	1	19	Poplar	
<input type="checkbox"/>	4	Drawer stops	$\frac{3}{4}$	$\frac{3}{4}$	2	Poplar	
Back and Moulding							
<input type="checkbox"/>	1	Top case back	$\frac{1}{2}$	$37\frac{1}{2}$	$45\frac{3}{4}$	Curly maple	Shiplapped
<input type="checkbox"/>	1	Bottom case back	$\frac{1}{2}$	39	28	Curly maple	Shiplapped
<input type="checkbox"/>	1	Crown moulding	$\frac{3}{4}$	$3\frac{5}{8}$	7'	Curly maple	
<input type="checkbox"/>	1	Top cap	$\frac{1}{2}$	$3\frac{3}{4}$	7'	Curly maple	
<input type="checkbox"/>	1	Waist moulding	$\frac{3}{4}$	$\frac{3}{4}$	7'	Curly maple	
<input type="checkbox"/>	1	Lower waist moulding	$\frac{3}{4}$	2	7'	Curly maple	
<input type="checkbox"/>	1	Base moulding	$\frac{3}{4}$	5	7'	Curly maple	

* Dimension includes a $\frac{7}{16}$ " cope on both ends. Check your cope-and-stick set before cutting your rails to length.



The bottom case uses a screw board to help support the top case and hold the back in place. Here I'm screwing the screw board to one of the bottom case's sides, flush to the inside edge of the rabbet.

back of the bottom case, as shown in the photo above.

Raised-panel Doors

The two doors are built using both a cope-and-stick joint and a loose mortise-and-tenon joint. In my opinion the loose tenon is necessary to add strength to these heavy doors. First, cut all your door parts to size. I make my doors the exact same size as the opening in the face frame. I trim them to fit the opening later.

Now mill $\frac{3}{8}$ "-wide by $1\frac{1}{16}$ "-deep mortises in the rails and stiles where the two meet and cut a $\frac{3}{8}$ "-wide by 2"-long loose tenon from scrap wood. Using a router in your router table, cope the ends of the door's rails with the coping bit. Now cut the mating stick profile on the inside edge of the door's stiles and rails. You can see how this joint fits together in the drawing at right. Don't assemble the door panel frame yet. First you want to size your door panels.

My panels have a 12° bevel

on the front face, but depending on the cutter set you own, the degree of your bevel might be different. That's OK.

I pre-cut all my raised panels on the table saw, and then finish raising them using my shaper. This keeps my shaper blades sharper longer, reduces the chance of major blowout and is safer.

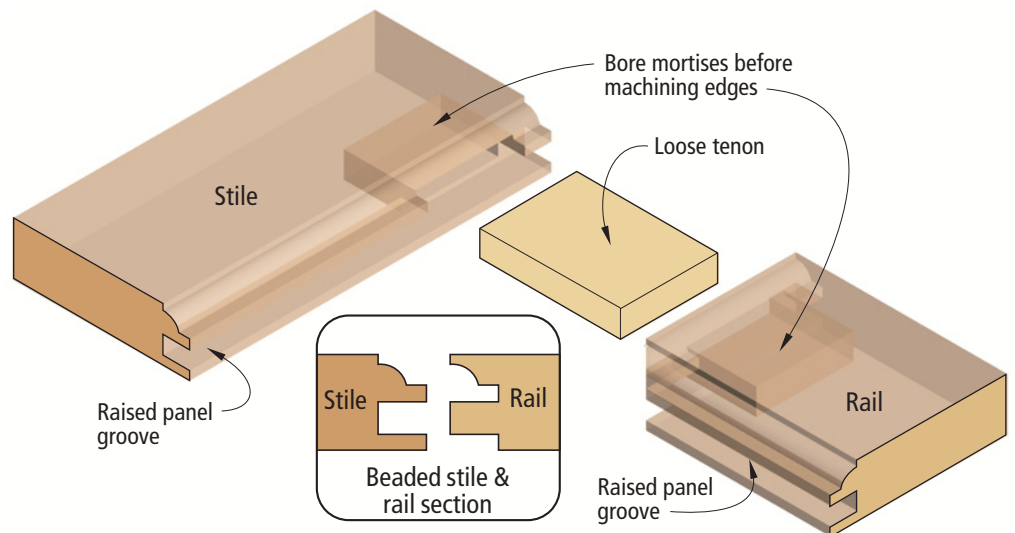

Door construction

Place your door panels into the door panel frames' grooves. Don't use glue. The door panels must float in the grooves to allow for wood expansion and contraction. You do want to use glue when assembling the door panels' frames. I like to peg my loose mortise-and-tenon joints for extra strength and authenticity.

Now it's time to fit the doors. Joint all four edges so that you have a $\frac{1}{16}$ " gap around the entire frame. You can make some $\frac{1}{16}$ " shims to help you fit the doors. Go ahead and sand the doors and hang them on their hinges.

Dovetailed Drawers

You can make your drawers any way you like, but for a traditional piece of furniture like this, I think dovetailed drawers are most appropriate. I cut all my half-blind dovetails with a simple router jig I created that costs \$19.99.

You can download free instructions for this technique at popularwoodworking.com. Click on "Free Project Plans" and scroll down until you see "\$19.99 Dovetail Jig."

Basically, the dovetail jig works like this: First you cut notches on one end of a piece of scrap using



The door panels are held together with a cope-and-stick, and a loose mortise-and-tenon joint.



Here you can see the finished pins on the drawer front.



After I lay out the tails on the drawers' sides, I cut them out using my band saw.

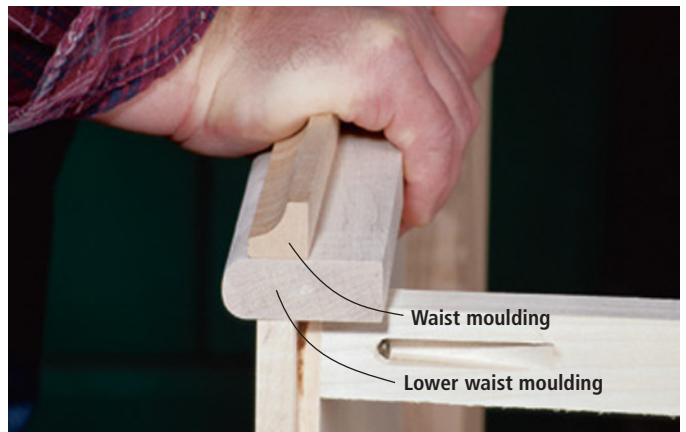

The two pieces of waist moulding are nailed to the top of the bottom case.

Cutting dovetails for the drawers is easy work if you use a template and a router. You can download free plans for my \$19.99 Dovetail Jig at popularwoodworking.com.

a dado stack in your table saw. One notch equals one pin socket. This is your template. Then you clamp your template to the back side of your drawer front. Install a template guide and dovetail bit in your router, set the depth and run the router in and out of the notches, as shown above. That's how you cut your pins.

Next, you use the pins to lay out the tails on the drawer side. Then you simply cut the tails using your band saw, as shown at right. The first time you try this, you might have to do a little fitting. But I guarantee this jig is an easy (and inexpensive) way to cut snug-fitting dovetails.

Before you fit your drawers, install the drawer runners to the two shelves in the bottom case. Four pieces of $\frac{3}{4}$ " x 1" x 19" hardwood will do just fine. Screw them

in place flush against the sides of the lower case.

Moulding and Finishing

Now it's time for the pieces that give a project like this some pizzazz. Start with the waist moulding that goes on top of the bottom case. Waist moulding plays an important part in projects when dealing with a top and bottom case. The top case sits on top of the lower waist mould. Once the waist mould is attached to the lower waist mould, gravity holds the top case in place. This way, you don't have to permanently attach the top case to the bottom case, making this piece of furniture much easier to move. You can see how the waist moulding fits together at right.

The first step in creating the waist mould is to cut a $\frac{3}{4}$ " bull-

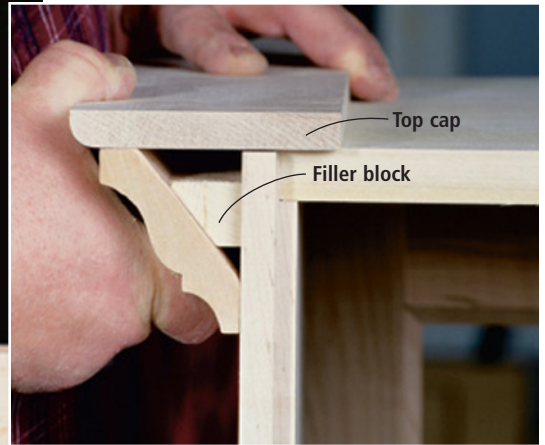

The crown is attached to the top case, along with a filler block and the top cap.

I attach a temporary board to my case to ensure that I attach my crown at a perfect 45° angle. When installing moulding to cases where the sides can expand and contract, glue and nail the moulding at the front third of the case only. The rest of the moulding on the sides should only be nailed, not glued.

nose on the 3/4" x 2" lower waist mould. This moulding should hang over the outside of the bottom case by 1/2", and it will give you 3/4" of moulding to nail into the bottom case. Miter the lower waist mould and nail it in place.

Now cut a 1/2" cove profile on the waist mould. Don't attach the waist mould to the lower waist mould yet. Set the top case on top of the lower waist mould that's attached to the bottom case. Make sure all sides are even. Draw a pencil line all the way around the top on the lower waist moulding.

Take the top case off of the bottom case. Now attach the waist mould to the lower waist mould, leaving the pencil line visible so you only have a pencil line amount

of room to play. (The sharper your pencil, the better the fit.)

Next, turn your attention to the moulding on the top of the top case. Attach a temporary board to the top of the top case, as shown above. This board will allow you to attach your top crown at a perfect 45° angle. I bought my crown off the rack. You can do the same, or cut your own. Go ahead and attach the top crown. Now, cut several filler blocks and place them between the top crown and the top case, as shown above. This gives the top crown extra support. Once your filler blocks are in place, attach the top cap.

Your last moulding step is to attach the base moulding. Use the scaled detail drawing as a pat-

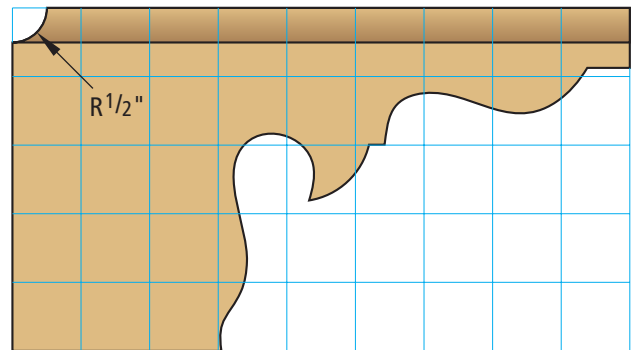

Base detail

1" grid

tern and cut out the scrollwork using your band saw or jigsaw. You'll need to cut away part of the lower case sides to get the base moulding looking correct. Miter and nail it in place.

I sand everything to 180 grit. Finish the project using your favorite stain or dye, and two or three coats of lacquer. **PW**

SUPPLIES

The pulls for the doors and drawers can be purchased from Horton Brasses (800-754-9127 or horton-brasses.com) or from Ball and Ball (800-257-3711 or ballandball.com). Call for pricing and availability.

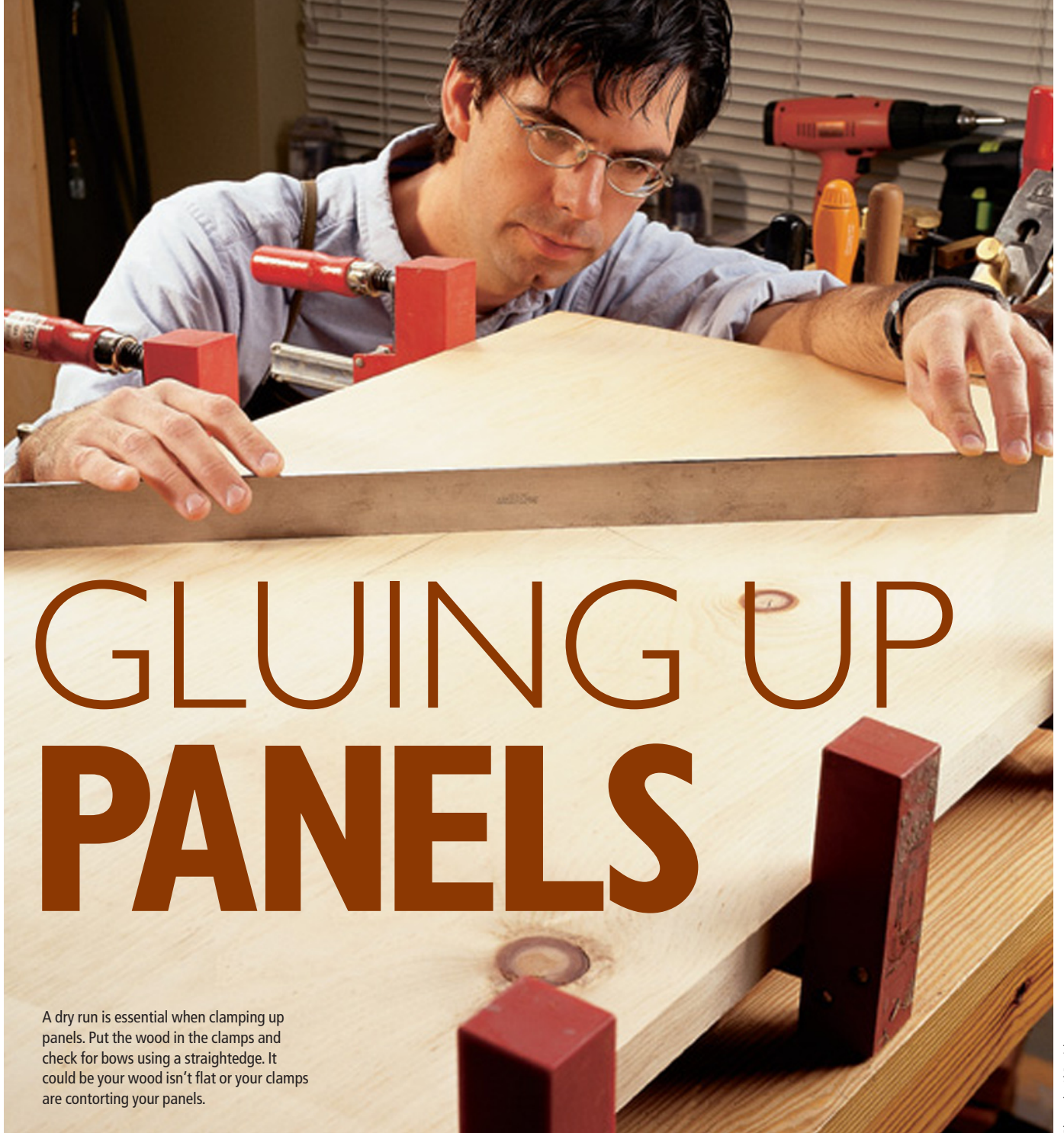

GLUING UP PANELS

A dry run is essential when clamping up panels. Put the wood in the clamps and check for bows using a straightedge. It could be your wood isn't flat or your clamps are contorting your panels.

Photos by Al Parrish

Perfectly flat panels that look like they were grown to be joined together are possible by following just a few simple rules.

For several years I was fortunate to live down the road from a logger. When he would come across a tree he thought might interest me, he'd give me a call. I'd excitedly put on my boots and gloves and prepare for hiking through rough terrain. The brush would snap and crack under our feet, and the thorns would

snag our clothing as we would trek through woods and across muddy fields. The results were well worth the hike through the mud; I now have stacks and stacks of richly colored walnut and cherry boards stashed in the barn. Some boards are as wide as two feet and the "narrow" boards are wide enough for many show surfaces such as

by Lonnie Bird

Lonnie Bird is the author of "The Complete Illustrated Guide to Shaping Wood" (The Taunton Press) and teaches woodworking. You can learn more about his woodworking classes at lonniebird.com.



When gluing panels, you'll get the best color and grain match by finding boards that were sawn consecutively from a tree. Look for knots, bark, saw kerfs and other clues that the boards were next to one another in their previous life. Look carefully at the photos and you'll see a sap streak that is consistent from one board to the next in this pair.

Sometimes the best way to find out if a board matches its neighbor is to look at the grain patterns. Take a block plane with you to the lumberyard to skim a little of the rough-sawn stuff off to get a look at the grain.



door panels, desk lids and small tabletops. (And despite what you've heard or read, you actually can keep those wide boards flat – but that discussion is the subject of another article.)

However, in spite of my stash of lumber on steroids there are still times that I need to glue several boards together to make a wide panel. Large tabletops, sides for casework and bottoms for drawers all come to mind. When I combine several boards to make a tabletop or other large panel, I want the finished panel to appear as one board as much as possible. After all, one of the many reasons I enjoy woodworking is be-

cause of the natural beauty of the material. I don't want to spoil the qualities of the wood by gluing together boards with distracting mismatched grain and color.

Matchmaker, Make me a Match

When selecting boards for a panel, you'll find that the best color and grain match comes from boards sawn from the same tree. In fact, I prefer planks that were sawn consecutively.

You can purchase matching lumber from one of the small, specialty hardwood dealers that advertise in the pages of *Popular Woodworking*. (You also can check

the "searchable links" section of this magazine's web site.)

The prices are higher from these merchants, but I think it's worth the extra cost for the premium lumber. If you're searching for matching boards at a large, commercial lumberyard, be aware that the boards are usually all mixed together with those from other trees. It requires a lot of organization and effort to keep the boards sorted by individual trees. Nevertheless, you can still find matching boards.

As you sift through the stack (ask permission and keep the stack neat), look for defects, saw kerfs and width. Knots, worm holes and other natural defects will all line up in consecutive boards. You also can look for short kerfs left over from the logger's chain-saw. As you spot boards with interesting figure, set them aside and search for their relatives.

Although it's not as easy to spot as knots or saw kerfs are, the grain pattern itself can be a way to identify matching boards. If you're looking at rough lumber you'll find it helpful to skim the surface with a block plane. (However, to avoid being kicked out of the lumberyard, before you try this technique, check with the lumber dealer first.) Another good match can often be had by cutting two shorter lengths from one long board.

Whatever method you use for matching boards, be careful to match the figure along the glue joint. Some types of figure match well while others don't. Although there are many types of grain or figure, cathedral grain and radial grain are the two most common. The two types are primarily a result of how the log was sawn; sawing "around the log" will yield cathedral grain, while plain sawing (not rotating the log) will yield boards with cathedral grain

in the middle and radial grain along the edges.

I prefer plain-sawn boards because it's easier to match the straight grain that appears along the boards' edges. Besides, boards sawn in this way typically are wider, and the resulting figure appears more natural to my eye than the figure from lumber sawn using other methods.

After selecting boards for the panel, the next step is to arrange them in order for glue-up. My old high school woodworking textbook stated that the boards should be arranged so that the annual rings on the ends of each board alternate up and down. The idea was that as the boards cupped either direction they would keep the overall panel flat.

This outdated idea typically results in a washboard surface with disjointed grain and color at all of the seams. Instead, I arrange the boards for the best color and grain match, and I ignore the annual rings. Warpage isn't a problem because I use dry (pre-shrunk, pre-warped) lumber and allow it to acclimate to my shop before milling it. Afterwards the construction of the piece will keep it flat.

For example, a door panel is held flat by the door frame and a desk lid is restrained by its two breadboard ends.

Mill it to Size

To create a flat glued-up panel, it's essential to begin with flat planks. And be aware that rough lumber is seldom flat. Neither is "dressed" or planed lumber because it was not flattened on a jointer before it was planed. You can flatten the boards on a large jointer (I have a large 16" jointer for this purpose) or use a long handplane such as a #6, #7, or #8. But first, cut each board approximately one inch longer than

needed. This helps to remove some of the warp.

After flattening one face of each board for the panel, plane the boards to final thickness. Finally, joint all the edges of the stock and use care to ensure that the edges are 90° to the face.

To ensure strong, long-lasting joints in the panel it's important that the edges are straight. Some woodworkers prefer that the joint is slightly concave; this is sometimes referred to as a "sprung" or "sprung" joint.

The idea is to place greater pressure at the ends to keep the joint tight in this area if the ends dry out and shrink. Although a sprung joint works effectively, I find that it isn't necessary. I simply joint the edges straight. However, convex edges should be corrected before glue-up. Otherwise they will introduce tension on the ends of the joint and it will most likely fail.

No Biscuits, Please

While some woodworkers use a number of devices such as splines, dowels and biscuits to strengthen an edge joint and aid with alignment, I simply spread the glue and apply the clamp pressure. Edge joints don't need additional strength; the joint is already stronger than the surrounding wood. And aligning is a breeze; just gently push and pull on the boards as you tighten the clamps.

Gluing up

The glue-up procedure should be performed on a flat surface; otherwise you can glue a twist into the panel. Sawhorses work well, but unless the panel is extremely large I usually just work on my bench, which is large and flat.

Before you begin, make sure that your clamps are straight; a bent pipe clamp can also create a problem in keeping the panel flat. As I position the clamps, I

alternate the clamps over and under the work to equalize the pressure on both sides of the panel. I space the clamps approximately 12" apart; closer if the wood is very hard or there are more than two boards in the panel.

I always perform a dry run and check the flatness of the panel and the fit of the joints before applying glue to the edges. Any potential problems are easily spotted in the dry run and corrected before the glue is applied. Before I disassemble the dry run I mark the pieces to ensure that I arrange the boards correctly during the actual glue-up.

Spread the Glue

When spreading glue you'll want just enough to wet the surface. I like to see a few drops of squeeze-out; it lets me know that the joint isn't glue-starved. However, too much glue creates a problem; it creates a big sticky mess and the

boards slide out of position as the clamp pressure is applied.

I begin by clamping in the middle of the panel and work to the ends. I push or pull the boards at the ends until they're aligned at the clamp. Then I apply pressure to that area.

Fingertips are quite sensitive and they can feel a few thousandths of an inch of mis-alignment. Once all the clamps are in place I allow the glue an hour or so to dry. Then I remove the clamps and scrape away the soft beads of glue along the joint line.

Keep it Flat

Once the glue has set, continue to work the panel to keep it flat. If left lying around the panel can warp as the humidity changes.

Finally, always apply finish to both faces of a panel. Otherwise the unfinished face will react sooner to changes in the weather and cause the panel to warp. **PW**



Joint all your edges before gluing up a panel. Some people like to use a "sprung" joint that has a slight bow in the middle. I find it unnecessary.



If you don't own a jointer, a jointer plane, such as this #7, can joint a perfect edge. It takes a bit of practice, but is not as difficult as you might think.



Photo by Al Parrish

Colonial *Chimney Cupboard*

While these tall, thin cabinets certainly look good alongside a fireplace, that's not what they were designed for. Rather they're called chimney cupboards because their tall, thin shape mimics a chimney. Usually designed for a particular spot in a house, the smaller footprint also made this a portable piece. As the family moved West perhaps, larger pieces of furniture were left behind, while this piece could easily make the journey.

These enclosed cupboards usually held the family's everyday dishes; fancier glass-front furniture displayed good china. I think everyday storage fits in better with current style, so I like this piece.



A traditional face frame, mitered beading and raised-panel doors turn this simple box into a finely detailed American specimen.

How the Pieces fit

Building this cupboard is pretty easy. I won't call it a weekend project, but if you've got a reasonable grasp of woodworking,

you'll be fine. The overall concept is a face-frame cabinet with two inset doors. The shelves are dadoed between the two sides, with two of the shelves serving

as the bottoms of the two sections. The top of the cabinet is simply screwed to the top of the sides, and the back is shiplapped and set into rabbets in the sides.

First Make the Face Frame

Construction begins with the face frame and includes one of the features that adds both a fun design feature and a slightly challenging joinery twist. The interior edge of the face frame has a $\frac{1}{4}$ "-wide bead. While some woodworkers might be inclined to run a roundover the edges on a $\frac{1}{4}$ "-thick strip then add it to the frame, I wanted to stay traditional and make the beading part of the frame. The photos will walk you through the three-step process to

by Glen Huey

Glen Huey builds custom furniture in his shop in Middletown, Ohio, for Malcolm L. Huey & Son, is a contributing editor for *Popular Woodworking* and is the author of "Fine Furniture for a Lifetime." You can see more of his work at hueysfurniture.com.

Using the cut list, mill all the face frame parts and use a 1/4" beading bit in your router to cut the beading. The detail should be on the inner edge of all exterior frame pieces and on both edges of the center rail. You can do this with a hand-held router or on a router table.



To form the side stile and rail mating locations, the beaded edge needs to be removed from the stiles. Set your table saw blade to a 45° bevel, then set the depth to just remove the beaded area (5/16"). Mark the locations of the three rails, then make the cuts in the side stiles. For the middle rail you need to make the cut for both angles and nibble away the waste material. Remove the waste for the top and bottom rails by resetting your table saw to 2 1/4" and make a rip cut to the mitered bead.



prepare the beading on the stiles and rails of the face frame.

Once the beading is accomplished, the joinery comes into play. Forming the mortise-and-tenon joints on the beaded face-frame pieces takes a little more attention, but the finished look is worth the effort.

I used a mortiser to create the 3/8"-wide x 1 1/16"-deep mortises

in the rails. I used my table saw to make the mating tenons. The photos below show this procedure step-by-step.

With the joinery on the face frame complete, you're ready to glue it up. Check the assembly

for squareness as you go, then set the frame aside to dry.

On to the Cabinet

The two sides of the cupboard are mirror images of one another, with 1/4"-deep x 3/4"-wide dados

to support the shelves and 1/2" x 3/4"-wide rabbets on the rear edge for the back boards. Use the illustrations to determine the shelf locations, then follow the pictures to rout the dados.

After cutting the back rabbets on the table saw, cut the shelves to size, sand the interior surfaces of the cupboard and glue them in place, using a brad nailer to keep things from moving. With the "box" assembled, glue the face frame to the carcass. As a final case step, peg the shelves through the sides as shown in the photo on a following page.

Next, mill the top to size and use a 1/2" roundover bit to shape the underside of the top's front

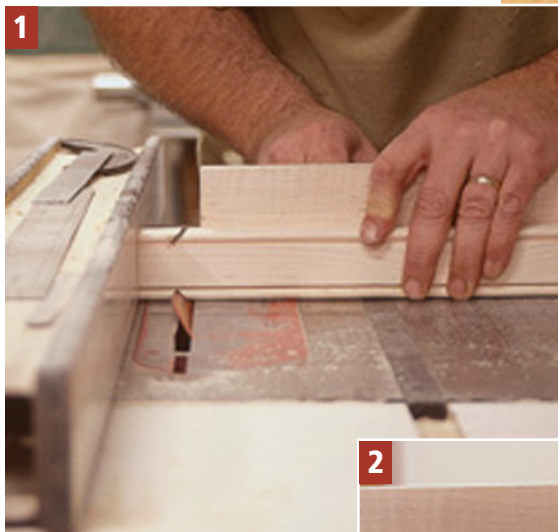

Begin cutting the tenons on the rails by cutting 45° angles through the beaded areas of the rails (above). Then reset the blade for a 90° angle and make a cut to define the shoulders of the tenons exactly where the angle terminates (right). Finally, set up and cut the cheeks for the tenons (above right), then test fit the rails into the stiles.

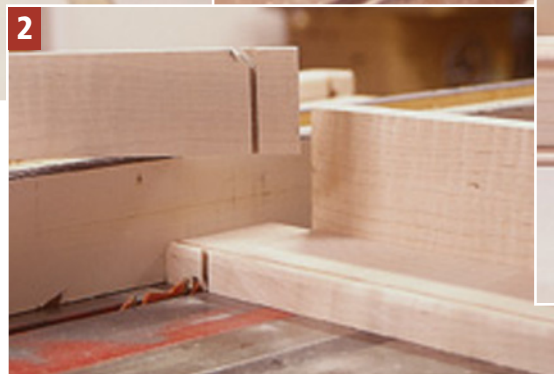

COLONIAL CHIMNEY CUPBOARD

NO.	ITEM	DIMENSIONS (INCHES)			MATERIAL	COMMENTS
		T	W	L		
2	Face-frame stiles	3/4	2 1/4	74 1/4	Maple	
1	Lower face-frame rail	3/4	2 3/4	16 1/8*	Maple	1" TBE
1	Middle face-frame rail	3/4	1 3/4	16 1/8*	Maple	1" TBE
1	Upper face-frame rail	3/4	2	16 1/8*	Maple	1" TBE
2	Cabinet sides	3/4	11 1/4	74 1/4	Maple	
5	Shelves	3/4	10 1/4	17	Poplar	
1	Top	3/4	12 3/4	19 1/2	Maple	
2	Upper door stiles	3/4	2 3/4	45 1/2	Maple	
2	Lower door stiles	3/4	2 3/4	22 1/4	Maple	
4	Door rails	3/4	2 3/4	10 1/2	Maple	1 1/4" TBE
1	Lower door rail	3/4	3	10 1/2	Maple	1 1/4" TBE
2	Small door panels	3/4	8 7/8	17 3/8	Maple	
1	Large door panel	3/4	8 7/8	21 5/8	Maple	
1	Back	5/8	17 1/2	75	Poplar	Shiplapped pieces
1	Door stop block	3/4	3	3	Poplar	
1	Upper back support	3/4	2	16 1/2	Poplar	

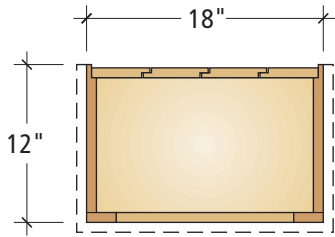

Plan

* Includes an extra 5/8" to accommodate the 5/16" bead removed from each stile.

TBE = tenon on both ends

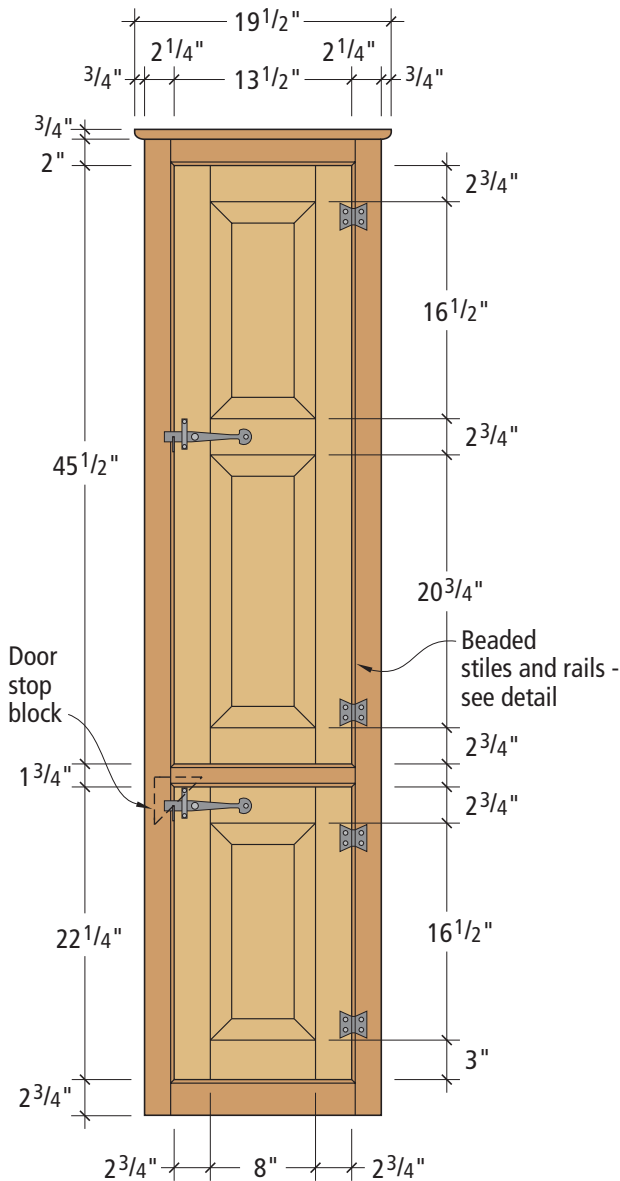

Elevation

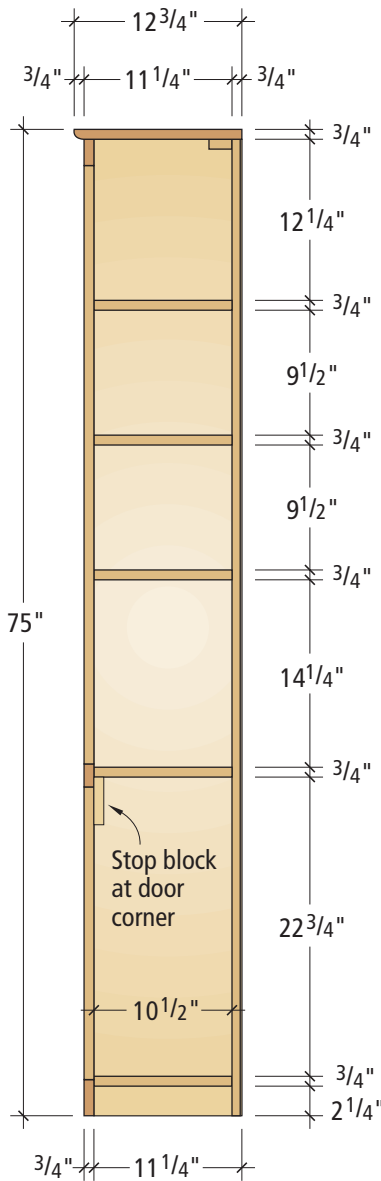

Section

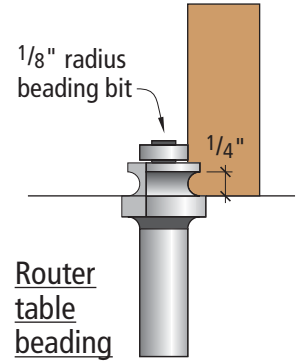

SUPPLIES

Horton Brasses, 800-754-9127

Door Latch: 2 - HF-24

Hinges: 2 pair - HF-12, 2" x 2"

or Ball and Ball, 800-257-3711

Door Latch: 2 - X620-C43

Hinges: 2 pair - H38-C56

Interior Finish:

Windsor Chair Green acrylic latex (#2013) from Olde Century Colors, oldecenturycolors.com, 800-222-3092

Exterior Finish:

Moser's Dark Wine Cherry aniline dye (W1420 water based), from Woodworker's Supply (800-645-9292 or woodworker.com)

and side edges. Pre-drill clearance holes in the top for screws and attach the top to the case.

Doors Keep Everything Tidy

Now move to the doors. The mortise-and-tenon construction on the doors is similar to how you made the face frame, but because the beading is already on the face frame, the doors are easier.

Cut the door stiles and rails to size using the cutting list, then lay out the mortise and tenon locations using the illustrations. Don't forget the $\frac{1}{4}$ "-wide by $\frac{3}{8}$ "-deep groove for the door panels. The panels themselves are beveled at 12° on the table saw. After a dry fit to make sure everything goes together easily, sand the panels and assemble the doors.

As with the case, the door joints benefit in appearance and strength by adding square pegs to the corners. Then fit the doors to the cupboard. I nailed a simple

Mill the sides of the cupboard to size, then lay out the shelf locations using the information in the illustrations. I used a router and a $\frac{3}{4}$ " pattern-cutting bit to form the dados in the sides. A simple L-shaped plywood guide clamped to the side makes a simple straight-edge jig. The pattern bit leaves a precise and flat-bottom groove, requiring very little clean-up.

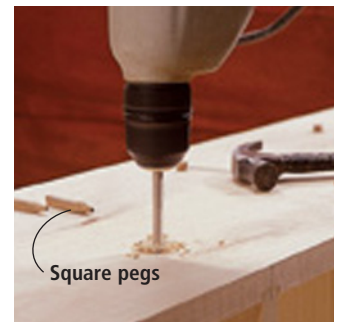
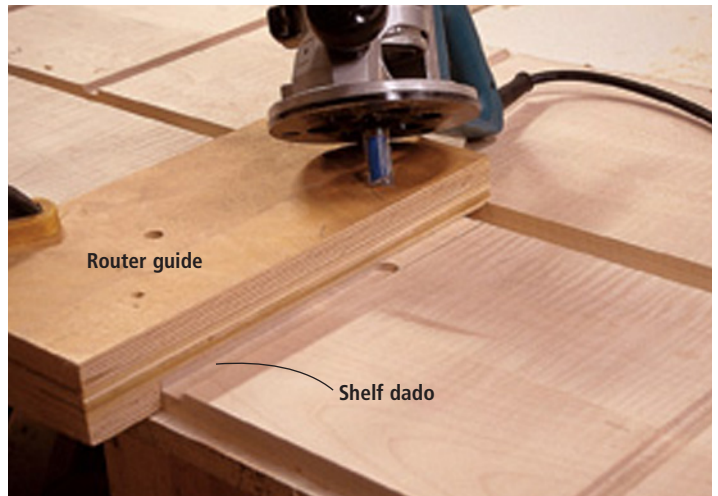

As a nice accent feature (and to add strength) I use square pegs to attach the sides to the shelves. Mark the location of each shelf, then measure in from the front and back edges of the side to 3" to mark the peg locations (two per shelf). Drill the location then tap the peg home. You'll notice I use a square peg in a round hole, but use a pencil sharpener to help the peg into place. Repeat the process for both sides.

With the dados and rabbets finished, I permanently attach the shelves to the sides using a square and brad nailer. By holding the nailer at a 45° angle to the corner from the underside of the shelf, I make a solid joint that's virtually invisible. With the shelves tacked in place to one side, flip the assembly over and repeat the process for the second side.

PERIOD HARDWARE PROVIDES THE FINISHING TOUCH

The black iron hardware really brings some character to this otherwise pretty plain piece of furniture. Installing the butterfly hinges is fairly straightforward, but the latches can be a little more complicated.

Start by laying the latch arm in position in order to mark the location of the recess for the catch. Recess the catch, then re-position the latch arm to be perpendicular to the case side and set screw.

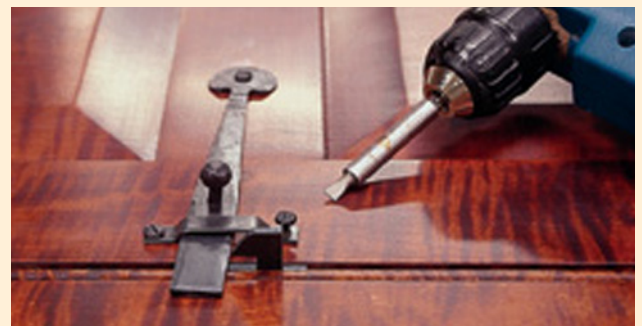
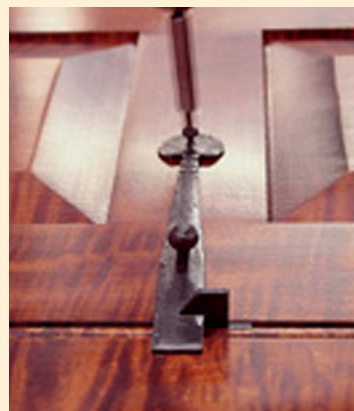

Raise the arm to just above the catch and place the keeper so that the top end is just above the raised arm. Set the screws in the keeper while making sure that it is parallel to the door edge.

triangular door stop behind the face frame. Finish sand both doors and the cupboard, then send it to the finishing room.

The Back and Finishing Touches

I used “Dark Wine Cherry” aniline dye stain from Moser. After the stain has dried, knock down the “fuzzies” with 400-grit paper and apply a coat of boiled linseed oil. Once that has dried, spray the piece with five coats of shellac (sanding between the third and fourth coats). For the final finishing touch, I hand rubbed the piece with #0000 steel wool and Behlen’s Wool-Lube.

The last details are cutting the shiplapped back to size. Paint it and the interior of the cabinet. Then install the back.

The wrought iron hardware I used on the piece may not be historically accurate, but I think it really dresses the piece up nicely, so the heck with historical accuracy. The photos and captions will walk you through installing the hardware. **PW**

With the cabinet assembled, follow the cut list to size the pieces of the door frames. Lay out and cut the mortises and tenons, remembering to use a haunch cut on the top and bottom rails (right). Next cut the groove in both the rails and stiles to accept the raised panels (below right). The panels themselves are raised by setting the table saw’s blade to a 12° and cutting to fit the 1/4”-wide groove.

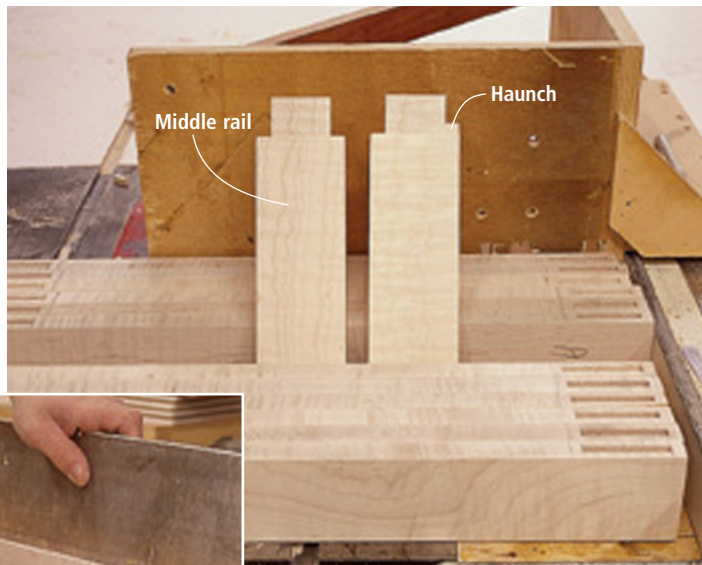

The back and interior of these cabinets were traditionally painted, so I followed suit. This makes it possible to cut and fit the back after the rest of the cabinet is finished. I used a traditional and simple shiplap joint to assemble the solid back pieces. I then applied two coats of “Olde Century Colors” acrylic latex paint (Windsor Chair Green) to the back pieces (at left) and the interior of the cabinet (right). Once the paint is dry, nail the back boards in place with a single nail, centered in each back board, top, middle shelf and bottom. Space the back boards evenly, leaving adequate room to allow for seasonal wood movement.



Four Joints for BOX MAKING

With four simple joints you can master either a traditional or contemporary blanket chest project, and learn some valuable joinery along the way.

A wise man once said that all furniture building is box making. He's still correct. A chest of drawers is simply a number of open-topped boxes slipped inside a larger box. If you can make a box, you can make nearly any kind of furniture designed for storage...we'll save chairs and tables for another time.

To help you along the way towards box (and furniture) making, we've come up with a couple of projects that actually are an excuse to talk about useful box-making joints. These two blanket chests use four basic and commonplace joints for corners: through-dovetails, rabbit joints, tongue-and-groove and biscuit joints.

Building a Traditional Chest

Let's start with the pine chest. We used through-dovetails on the front corners and a rabbit joint on the rear corners. Start by gluing up the panels for the front, back and sides. They should finish out $\frac{1}{8}$ " or so longer than the cutting list calls for to allow room for the pins and tails to extend past the joint; they will later be sanded (or planed) flush to the case sides.

Through-dovetails

Let's talk about the dovetail joint. Most woodworkers consider the dovetail joint a hallmark of quality craftsmanship. It truly is an amazingly strong method of joinery and adds a nice visual detail to a piece of furniture. We used a through-dovetail (meaning the joinery is visible from both sides of the corner) because it's the more traditional dovetail joint for blanket chest construction. When using power tools, it's actually a little harder to create than half-blind dovetails, which are seen from only the side of the case. Dovetails are not only useful in case joinery, but are used extensively for drawers and smaller decorative boxes as well.

When approaching dovetail joinery you should first decide whether you're going to learn to cut the joint by hand, or invest in one of the many dovetail jigs that use a router to form the joint. We don't want to make this an article debating the pros and cons of each method, but we should talk about both, briefly.

Cutting dovetails by hand can be an immensely rewarding and liberating skill.

We built blanket chests in traditional and contemporary styles to show off four box-making joints.



By David Thiel and Kara Gebhart

Comments or questions? Contact David at 513-531-2690 ext. 1255 or david.thiel@fwpubs.com, or Kara at ext. 1348 or kara.gebhart@fwpubs.com.



Photos by Al Parrish



After laying out the dovetail locations, set up the jig and router following the manufacturer's directions. Cut the tails first with the dovetail bit, then use the opposite side of the jig with a straight router bit to cut the pins on the mating piece. With careful setup, a smooth fit is accomplished even if it's your first set of dovetails.



to make the cuts. However, the convenience of quickly cutting a row of dovetails in less than an hour is a strong argument for spending the money.

There are a number of jigs capable of making quality dovetail joints. For our particular chest we chose a Keller dovetail jig because it offered the best width capacity for making our dovetails at a reasonable price.

To make our through-dovetail joints (the two front joints in the pine chest), we first prepared the wood, making the panels the appropriate thickness ($\frac{3}{4}$ "), width (in this case the width of the wood is the height of the chest to allow for seasonal wood movement because of changes in moisture content) and length. Dovetails should always be cut on the end-grain ends of a board to provide the strongest joint. Cut your front, back and sides a $\frac{1}{16}$ " to $\frac{1}{8}$ " longer to allow for sanding or planing the joint flush to the sides.



To cut the rabbet for the back corner joints on the pine chest, we used a two-step process on the table saw. First, cut the width of the rabbet, with the saw height set just shy of the rabbet width dimension (above). Next reset the fence and blade height to trim away the rabbet waste in an upright cut. Notice the waste piece will fall away from the blade, avoiding a dangerous trapped scrap piece.



It allows you to adjust the size, location and number of pins and tails used in the joint, something less easy when using a router jig. It also allows you to work with a minimal amount of noise and dust. One drawback is the amount of time necessary to feel comfortable in cutting into your carefully prepared lumber.

One argument we've heard for hand-cut dovetails is the expense involved in purchasing a router and dovetail jig. Don't fool

yourself. Quality hand tools for hand-cut dovetails can quickly run up the credit-card balance.

For this article we opted for a dovetail jig for our router. Making hand-cut dovetails is a full article in its own right, and we'll simply refer you to Ian Kirby's "The Complete Dovetail" (Linden Publishing) for more in-depth instruction on that.

When using a dovetail jig with a router, you'll run into the aforementioned noise and dust, as well

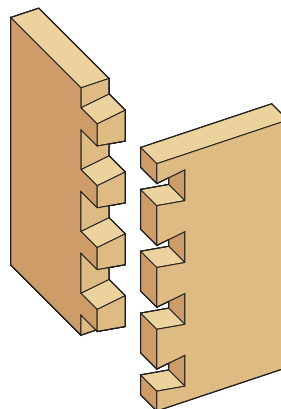

Through-dovetails

as a learning curve that is shorter than with hand-cut joints, but needs to be relearned when different thicknesses are used with the jig. Then there's the expense.

There are a variety of dovetail jigs available, but even the least expensive will cost more than \$150 and that won't include the necessary bits or the router

With the wood panels prepared, head to the dovetail jig with a piece of scrap left over from sizing the panels. No matter what jig you're using, the critical detail is to get the jig set up accurately. You'll usually start by cutting the "tails" part of the joint first (though some half-blind jigs cut both simultaneously). First determine the location and layout for the dovetails. Follow the instructions for the jig to lay out and cut the tails.

TRADITIONAL BLANKET CHEST

NO.	ITEM	DIMENSIONS (INCHES)			MATERIAL
		T	W	L	
❑ 1	Front	$\frac{3}{4}$	19	$35\frac{7}{8}$	Pine
❑ 1	Back	$\frac{3}{4}$	19	$34\frac{7}{8}$	Pine
❑ 2	Sides	$\frac{3}{4}$	19	$18\frac{1}{2}$	Pine
❑ 1	Top	$\frac{7}{8}$	$19\frac{1}{8}$	$37\frac{1}{2}$	Pine
❑ 1	Bottom	$\frac{5}{8}$	$35\frac{7}{8}$	$18\frac{1}{2}$	Pine
❑ 2	Base mouldings	$\frac{3}{4}$	3	$37\frac{3}{8}$	Pine
❑ 2	Side mouldings	$\frac{3}{4}$	3	20	Pine
❑ 2	Battens	$\frac{3}{4}$	$2\frac{1}{2}$	15	Pine

Once the tails are cut, adjusting the jig to make your pins fit is the important part. Though it requires tinkering to adjust the bit in the router and the jig itself, once it's right you'll be able to make as many perfect dovetails as you like.

After checking the fit of your dovetails, the hard part is really over. The rear joint, the rabbet joint, is formed on the sides only by making two passes on the table saw. Here's how to make it:

Rabbet Joint

For the rear joint on the pine chest we opted for a very simple joint, but one still reasonably strong and appropriate for the case. The rabbet joint requires cutting a rabbet in the back edge of both sides. The width of the rabbet should equal the thickness of the

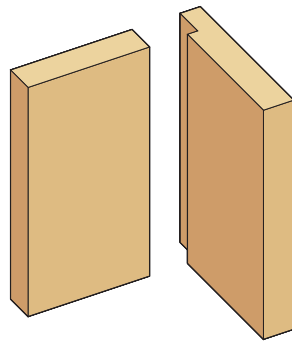

Rabbet joint

stock. The depth of the rabbet should be one-third to two-thirds the thickness of the stock.

The back then nests into the rabbets in the sides and is nailed in place through the sides. We used 1/4" x 3/4" rabbets, cut in two passes on the table saw (see photo at left). While this isn't the strongest joint for casework, the nails provide excellent strength, while the rabbet joint provides stability and squareness. It's also a quick and simple joint to pre-



The rear rabbet joint is a better joint than a butt joint for stability, but some glue and a few nails make it an even better joint. To make the nails more attractive, we used antique-looking cut nails.

pare that will provide adequate strength for most boxes.

With the rabbet joint complete, it's almost a box. You can go ahead and glue the four sides together. Glue should be applied

to all the "walls" of the dovetails in an even coat. When clamping the dovetail joint, use cauls as long as the box is high and placed directly behind the pins and tails. This allows the pins to extend beyond the tails in the joint, forming a tight joint. Put glue on the two surfaces of the rabbets and slip the back in place. Add clamps and check for square, measuring across the corners of the box.

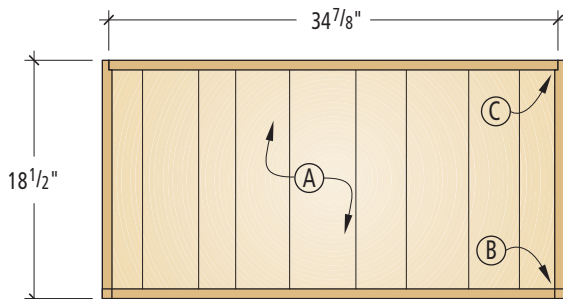

Plan - lid removed

Construction Notes:

- (A) Random-width shiplapped boards screwed to bottom of case
- (B) Through-dovetail corner joint
- (C) 3/4" w. x 1/4" d. rabbet joint w/ cut nails
- (D) 1/4" x 1/4" chamfer, typical
- (E) Hinges mortised into case
- (F) Lid battens

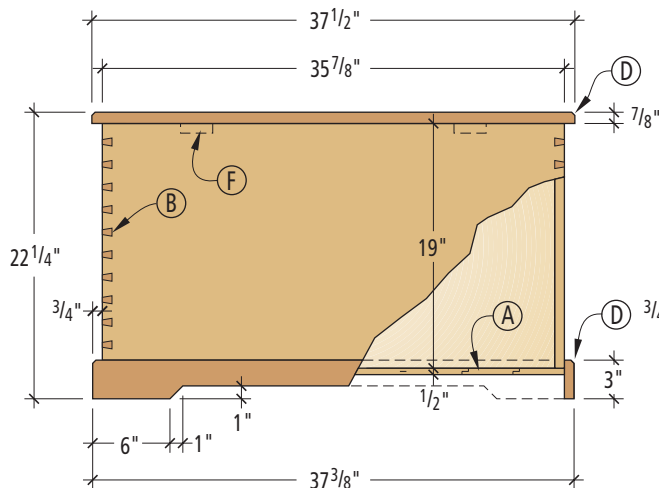

Elevation - section

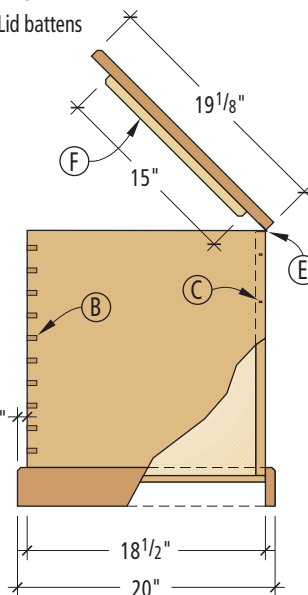

Profile - section

SUPPLIES: TRADITIONAL BLANKET CHEST

Hardware from Lee Valley
leevalley.com, 800-871-8158

2 • 10" lid supports
00S02.10 - \$5.10 each

4 • 1 9/16" x 2" hinges
01H24.10 - \$2.70 each

4 • 2" -dia. casters
00K26.50 - \$4.90 (pkg. of 4)

1 • 1/4 lb. cut nails
91Z40.25 - \$3.60

Dovetail jig from Keller & Co.
kellerdovetail.com
800-995-2456

1 • Journeyman 22"
dovetail system
model 2200 - \$219.00

The bottom pieces are shiplapped (with opposing rabbet cuts on the long edges) except for the two outer boards that are left square cut. Screw the pieces in place with a single screw on each end, pre-drilled and centered on the board. Use dimes (as shown here) to evenly space the boards – this will allow for wood movement.



To add some extra strength and a nice look to the piece, Kara nailed the rabbet joints together with square-cut nails. Pre-drill holes for the nails to keep the ends of the sides from splitting. Once the glue on the joints has dried, sand or plane the parts of the pins and tails extending be-

yond the case surfaces flush, and the joint is complete.

With the box assembled, it's time to add a bottom. Because we were already familiar with cutting rabbets on the saw, we opted for a shiplapped bottom. By cutting rabbets half the thickness of the bottom pieces on alternating

long edges of each bottom piece, you'll create a strong and gap-free bottom. Cut the bottom pieces to fit the depth of the chest, front-to-back. Start with one bottom board with only one side rabbet-cut. Attach it to the bottom of the box, screwing only through the center of the board, one screw

at each end. Add the boards along the width of the chest, again, using one screw on each end of each board. When you reach the other end of the box, cut the width of the last board to fit the box.

To hide the edges of the bottom boards and dress up the blanket chest, cut the base mouldings to size. We added a $\frac{1}{4}$ " chamfer to the top edges of the base mouldings to soften the look, then mitered the corners and glued and nailed the base in place. The dimensions given in the diagrams are designed to allow the specified casters to extend below the base by $\frac{3}{4}$ ", leaving ample room for movement on carpet.

Next, cut the top to size, allowing $\frac{13}{16}$ " overhang on each side and $\frac{5}{8}$ " to the front. Screw two battens to the underside of the top, using elongated holes. The battens help keep the top flat, and the elongated holes allow the wood to move with seasonal humidity changes.

Four butt hinges attach the top to the case, and two lid supports hold the lid open. After some sanding, we added a few coats of orange shellac for a simple finish.

Miter the base moulding pieces to fit, then cut away the front and rear pieces in the center to lighten the look of the piece. When ready, all four pieces are glued in place around the chest bottom. A brad nail or two, or a triangular shaped support block behind the mitered corners isn't a bad idea to add some additional support.



Building the Plywood Chest

Building a chest out of plywood simplifies some things and complicates others. It's not necessary to worry about seasonal wood movement, but you do have to hide the plywood edges to make things look nice.

While we used two different corner joints for the plywood chest shown (tongue-and-groove and biscuit) it would probably make sense for you to choose one or the other joint and use it for all four corners. Whichever joint you're using, start by cutting the four corner pieces to size. We chose quartersawn sycamore.



Biscuit joinery is fast, simple and almost foolproof. After marking the six locations per corner, it's a simple matter to cut the slots in the center of the plywood edges, then reset the fence to add $\frac{1}{4}$ " in height (to allow for the $\frac{1}{4}$ " recess on the panels) and cut the slots in the corner pieces.

Biscuit Joints

If you're using biscuit joinery, the blocks are ready for your cuts. Lay out the biscuit locations on the blocks and cherry plywood panels. The blocks are held flush to the top of the panels, but they'll stop short of the bottom edge of the panels. That's OK.

The biscuit joint is a variation on the tongue-and-groove joint. Essentially what's changed is rather than use a table saw to first cut a tongue and then cut a groove, a biscuit joiner uses the same blade and tool to cut matching "slots" or pockets. Then a flat, football-shaped manufactured biscuit is slid into the matching pockets, forming a loose tongue. This is a fast, reasonably foolproof and forgiving method of joining the panels to the posts. While not as strong as a tongue-and-groove joint, it's adequate for many applications.

We liked the look of the $\frac{1}{4}$ " recess of the panels, so it made it necessary for us to readjust the height adjustment on the biscuit joiner when cutting the panels versus the blocks. Cut all the biscuit slots (we used three #20 biscuits per joint).

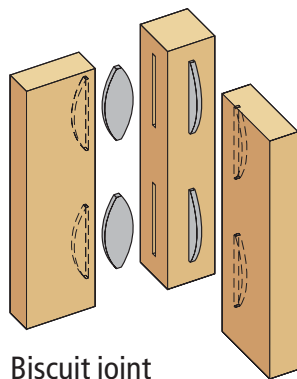

Biscuit joint

Tongue-and-groove

The tongue-and-groove that we've used on the plywood chest is the simplest to cut, and it offers a side benefit as well. A tongue-and-groove is often cut so that the protruding "tongue" part on the panel is centered on the thickness of the piece and the tongue is one-third the thickness of the piece. This is fine, but it requires cutting from both sides of the panel. We chose to form our tongue by cutting a rabbet on one side of the panel, leaving the tongue flush with one face of the panel. In our opinion, this leaves a stronger tongue. When the groove is cut in the opposite piece (or in our case the corner post) it is cut off-center to locate the

With the biscuit slots cut, a dry fit is always a good idea. It also helps you to visualize how and where the clamps need to be oriented to successfully glue up the case.

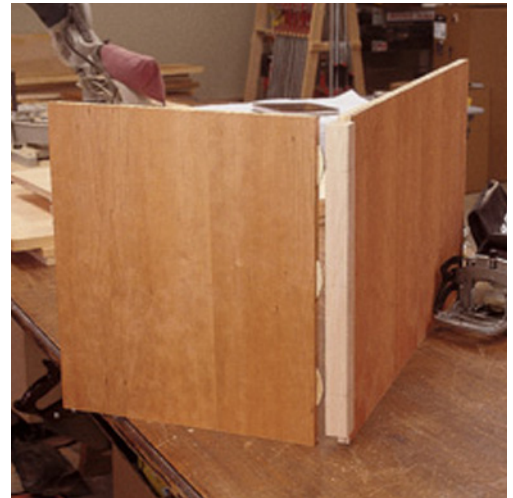

To cut the grooves for the tongue-and-groove joints, make repeat cuts on the table saw, starting with the "outside" edge to set the $\frac{1}{4}$ " offset. Cut both sides, then reset the fence, working your way in until you have the appropriate tongue thickness.



With the tongues cut (in this case using the same rabbeting cut as used in the other chest) a dry-fit is again in order. Because the tongue is positioned to the outside of the cabinet, there's no concern of an inaccurate shoulder cut showing up on the outside.

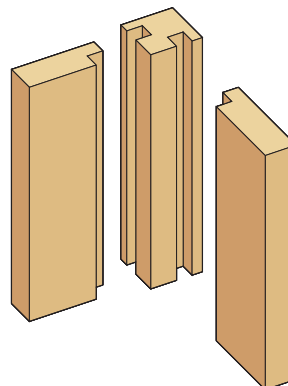

Tongue-and-groove joint

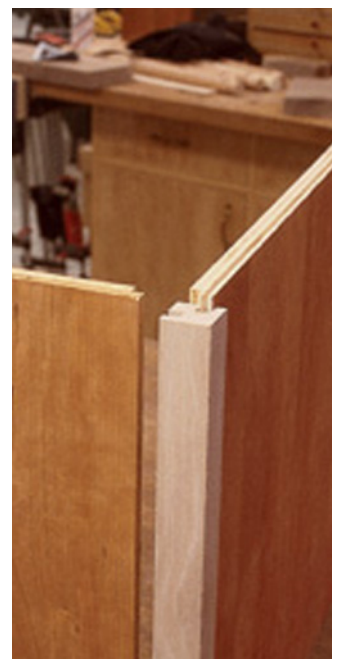

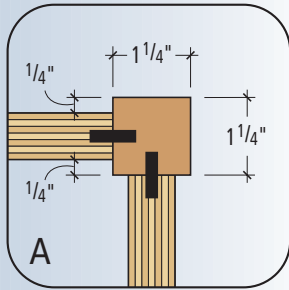

Biscuited corner post

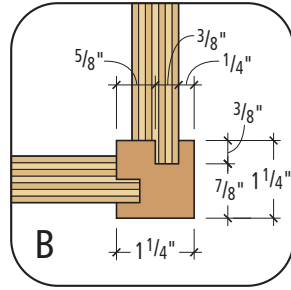

Tongue-and-groove corner post

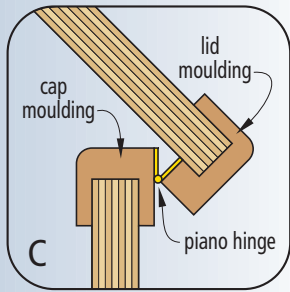

Hinge detail

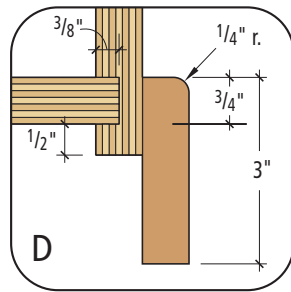

Base moulding

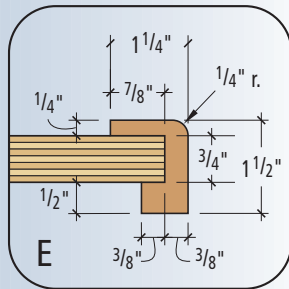

Lid moulding

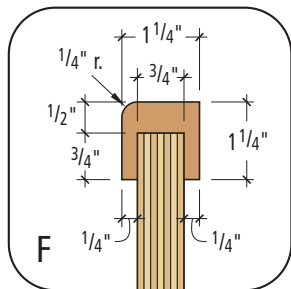

Cap moulding

PLYWOOD BLANKET CHEST

NO.	ITEM	DIMENSIONS (INCHES)			MATERIAL
		T	W	L	
□ 2	Front & back	3/4	33 3/8*	19	Plywood
□ 2	Sides	3/4	16 3/8**	19	Plywood
□ 1	Bottom	3/4	17 1/4	33 5/8	Plywood
□ 1	Top	3/4	19 7/8	36	Plywood
□ 4	Corner posts	1 1/4	1 1/4	17 3/4	Hardwood
□ 2	Cap mouldings	1 1/4	1 1/4	34 7/8	Hardwood
□ 2	Cap mouldings	1 1/4	1 1/4	18 5/8	Hardwood
□ 2	Lid mouldings	1 1/4	1 1/2	36 3/4	Hardwood
□ 2	Lid mouldings	1 1/4	1 1/2	20 5/8	Hardwood
□ 2	Base mouldings	3/4	3	35 7/8	Hardwood
□ 2	Side mouldings	3/4	3	19 5/8	Hardwood
□ 2	Accent strips	1/4	1 1/4	17	Hardwood

*For biscuit joint, change to 32 3/8".

** If using biscuit joint, change to 16".

panel where needed. Again, for our needs, we used solid corner posts to both hide the plywood edges and form a 1/4" offset between the panels and posts. With the offset tongue, the point where the tongue enters the groove in the posts helps to hide any part of the tongues' rabbet from the outside of the case.

To form the tongue-and-groove joinery, use the detail drawings to locate the grooves in the posts, then use the table saw to cut the grooves. To form the tongues on the plywood, cut rabbets on the panels using the same technique shown in the traditional chest.

Before gluing up the corners, head to the table saw and cut 3/4" x 3/8" dados, 1/2" up from the bottom of each panel. These dados will house the plywood bottom. Now cut the bottom to size to fit into the dados, then glue the chest together, capturing the bottom in place. You'll notice the corner blocks stop even with the top surface of the bottom.

The next step is to hide the top edges of the plywood panels. We cut "U"-shaped caps to slip over the plywood edges. To let the caps meet at the corners, we cut away part of the sides of the caps, then mitered the cor-

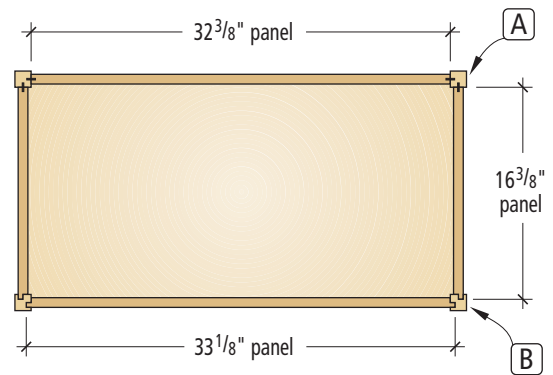

Plan - lid removed

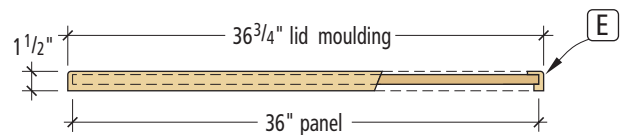

Lid elevation - section

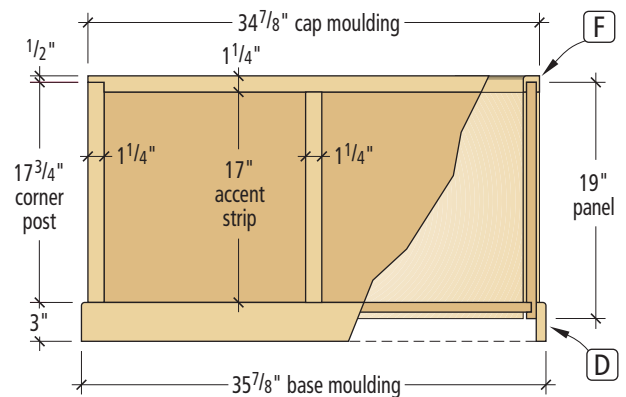

Elevation - section

ners. Follow the photos to form the top corners. Then glue and nail the caps in place.

We added a 1/4" roundover bit in a router on the top edge of the base moulding to soften the look of this chest. The base on the plywood chest is cut and attached by nailing through the 1/2" of exposed panel below. Next, glue and nail on some accent strips on the front and back of the chest to add a nice detail.

The top on the plywood chest is complicated by the need to hide the unsightly plywood edges. We took this opportunity to allow the top to lip over the case, adding another extra detail. Follow the diagrams to cut the lid moulding to size and shape, then miter, glue and nail the moulding to the plywood top piece.

Once again, the casters are attached to extend below the base. We used a continuous (or piano) hinge on this case, and had to attach it in an unusual fashion to allow the top to open smoothly. Follow the diagrams to determine the attachment location. We also



To miter the caps and allow them to successfully slip over the corner blocks, the mouldings should first be mitered to fit, then the corner block locations marked. Then it's simply some careful band-saw work. First define the cutout height (above), then use a miter gauge on the band saw to cut away the waste block (upper right). It's wise to cut short of the line and refine the fit a little at a time. This can be done with a flat file also, if your band saw isn't leaving a very clean cut line.

used a different type of lid stop that has adjustable closing tension to keep the lid from slamming closed. Follow the directions from the manufacturer to attach the lid stops. **PW**



Attach the base moulding by nailing it to the case from the inside as shown. I used spring clamps to hold the base moulding while nailing it in place.

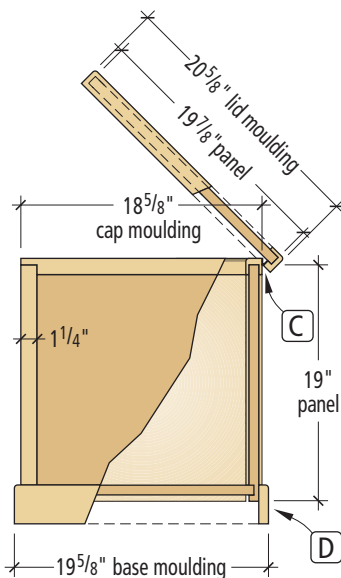

Profile - section

SUPPLIES: PLYWOOD BLANKET CHEST

Hardware from Lee Valley
leevalley.com
800-871-8158

2 • soft-down flap stays
00T02.10 - \$18.40 each

4 • 2" -dia. casters
00W09.10 - \$4.40 (pkg. of 4)

1" x 3" nickel piano hinge
from local hardware store

PRODUCT INDEX

	PAGE #	CIRCLE #	WEB ADDRESS
ADHESIVES			
Gorilla Glue	10	123	gorillaglue.com
Polymeric Systems	94	146	epoxysticks.com
BITS, BLADES & CUTTERS			
Amana	37	101	amanatool.com
Forrest Mfg.	31	119	stores.yahoo.com/forrestman
Freud	11	120	freudtools.com
Hickory	19	141	oldham-usa.com
Librawood	94	135	librawood.com
Oldham	C4	126	oldham-usa.com
Olson	33	142	olsonaw.com
PS Wood	44	147	pswood.com
Ridge Carbide	94	148	ridgecarbide.com
Routerbits.com	94	150	routerbits.com
Woodline USA	12	165	woodbits.com
BOOKS			
Woodworker's Book Club	Insert	—	woodworkersbookclub.com
BUILDINGS & WORKSHOPS			
U.S. Buildings	94	157	us-buildings.com
FASTENERS			
Arrow	39	102	arrowfasteners.com
McFeely's	22	137	mcfelys.com
Miller Dowel Co.	13	138	millerdowel.com
Waterlox	94	159	waterlox.com
FURNITURE & PROJECT PARTS			
Adams Wood Products	29	100	adamswoodproducts.com
DCT Holdings	94	113	dctleathers.com
Osborne Wood Products	89	144	osbornewood.com
HAND TOOLS			
David Warren Direct	94	—	ecemmerich.com
DMT	20	116	dmtsharp.com
Glen-Drake	32	122	glen-drake.com
Lee Valley/Veritas	6	134	leevalley.com
Lie-Nielsen Toolworks	33	136	lie-nielsen.com
Tools For Woodworking	20	155	toolsforworkingwood.com
HARDWARE			
Ball & Ball	18	104	ballandball-us.com
Whitechapel Ltd.	37	160	whitechapel-ltd.com
KITS & PLANS			
Bunk Beds	94	109	—
Murray Clock	95	140	murrayclock.com
Shortridge Co.	94	154	shorridgelt.com
U-bild.com	94	156	u-bild.com
Winfield Collection	94	162	thewinfieldcollection.com
Woodprojects.com	94	169	woodprojects.com
MISCELLANEOUS			
Dakota Alert	94	112	dakotaalert.com
POWER TOOL ACCESSORIES			
Beall Tool	94	105	bealltool.com
Bench Dog Tools	6	106	benchdog.com
Excalibur by Sommerville	44	117	excalibur-tools.com
Jointech	24	131	jointech.com
Keller Company	18	132	kellerdovetail.com
Leigh	26, 89	—	leighjigs.com
POWER TOOLS			
Ashman Technical	37	103	woodworktools.com
Bosch	23	108	boshtools.com
Delta Machinery	16-17	114	deltamachinery.com
DeWalt	30	115	dewalt.com
Fein Power Tools	27	118	feinusa.com
General Mfg.	22	121	general.ca
Grandberg Int'l.	95	124	granberg.com
Grizzly Industrial	C2-1	125	grizzly.com

	PAGE #	CIRCLE #	WEB ADDRESS
Jet Tools	5	128	jettools.com
Jet Tools	7	129	jettools.com
Jet Tools	9	130	jettools.com
Laguna Tools	2	133	lagunatools.com
MiniMax	29	139	minimax-usa.com
Ryobi	35	151	ryobitools.com
Sears Craftsman	C3	153	craftsman.comSenco
Senco	32	152	senco.com
Wilke Machinery	45	161	wilkemach.com
Woodstock Int'l.	25	167	woodstockinternational.com
SAWMILLS & KILNS			
Better Built	20	107	ripsaw.com
Wood-Mizer	39	163	woodmizer.com
SHOP ACCESSORIES			
Controlled Energy Corp.	29	110	contolledenergy.com
JDS Company	33	127	thejdscompany.com
Oneida Air Systems	29	143	oneida-air.com
TURNING SUPPLIES			
Craft Supplies	33	111	woodturnerscatalog.com
Packard Woodworks	94	145	packardwoodworks.com
WOOD & VENEERS			
Newton Woods	95	—	walnutwoods.net
Wall Lumber	37	158	walllumber.com
West Penn Hardwoods	18	—	westpennhardwoods.com
WOODWORKING CATALOGS			
Rockler	24, 37	149, 170	rockler.com
Woodcraft	14-15	164	woodcraft.com
Woodworker's Choice, The	21	168	thewoodworkerschoice.com
Woodworker's Supply	29	169	woodworker.com

See something you want? Need more information?

Use the Free Information Card in this issue to receive free advertiser information.

For **faster service**, go **online** at www.popwood.com and click "FREE INFORMATION" or **fax the card** to (716) 321-0043.

Win A Forrest Woodworker II Saw Blade

When you request information, you're automatically entered in our drawing to win a Forrest Woodworker II 10" saw blade. Tighten on this Forrest blade to your table saw and enjoy the best cuts you've ever seen—with no scratches or tearout. We'll select one lucky winner from the first 200 information requests received from this issue.

(See Advertiser Index or Product Index for circle numbers.)



ADVERTISER INDEX

ADVERTISER	PAGE #	CIRCLE #	WEB ADDRESS
Adams Wood Products	29	100	adamswoodproducts.com
Amana	37	101	amanatool.com
Arrow Fasteners	39	102	arrowfasteners.com
Ashman Technical	37	103	woodworktools.com
Ball & Ball	18	104	ballandball-us.com
Beall Tool	94	105	bealltool.com
Bench Dog Tools	6	106	benchdog.com
Better Built	20	107	ripsaw.com
Bosch	23	108	boschtools.com
Bunk Beds	94	109	—
Controlled Energy Corp.	29	110	controlledenergy.com/pw
Craft Supplies	33	111	woodturnerscatalog.com
Dakota Alert	94	112	dakotaalert.com
David Warren Direct	94	—	ecemmerich.com
DCT Holdings	94	113	dctleathers.com
Delta Machinery	16, 17	114	deltamachinery.com
DeWalt Tools	30	115	dewalt.com
DMT	20	116	dmtsharp.com
Excalibur by Sommerville	44	117	excalibur-tools.com
Fein Power Tools	27	118	feinusa.com
Forrest Mfg.	31	119	stores.yahoo.com/forrestman
Freud	11	120	freudtools.com
General Mfg.	22	121	general.ca
Glen-Drake	32	122	glen-drake.com
Gorilla Glue	10	123	gorillaglu.com
Grandberg Int'l.	95	124	granberg.com
Grizzly Industrial	C2, 1	125	grizzly.com
Hickory Woodworking	19	141	oldham-usa.com
JDS Company	33	127	thejdscompany.com
Jet Equipment & Tools	5	128	jettools.com
Jet Equipment & Tools	7	129	jettools.com
Jet Equipment & Tools	9	130	jettools.com
Jointech	24	131	jointech.com
Keller Company	18	132	kellerdovetail.com
Laguna Tools	2	133	lagunatools.com
Lee Valley/Veritas	6	134	leevalley.com
Leigh	26, 89	—	leighjigs.com
Librawood	94	135	librawood.com
Lie-Nielsen Toolworks	33	136	lie-nielsen.com
McFeely's	22	137	mcfelys.com
Miller Dowel Co.	13	138	millerdowel.com
MiniMax	29	139	minimax-usa.com
Murray Clock	95	140	murrayclock.com
Newton Woods	95	—	walnutwood.net
Oldham	C4	126	oldham-usa.com
Olson Saw Co.	33	142	olsonsaw.com
Oneida Air Systems	29	143	oneida-air.com
Osborne Wood Products	89	144	osbornewood.com
Packard Woodworks	94	145	packardwoodworks.com
Polymeric Systems	94	146	epoxysticks.com
PS Wood	44	147	pswood.com
Ridge Carbide	94	148	ridgecarbide.com
Rockler	24, 37	149, 170	rockler.com
Routerbits.com	94	150	routerbits.com
Ryobi	35	151	ryobitools.com
Sears Craftsman	C3	153	craftsman.com
Senco	32	152	senco.com
Shortridge Co.	94	154	shorridgelt.com
Tools for Woodworking	20	155	toolsforworkingwood.com
U-bild.com	94	156	u-bild.com
U.S. Buildings	94	157	us-buildings.com
Wall Lumber	37	158	walllumber.com
Waterlox	94	159	waterlox.com
West Penn Hardwoods	18	—	westpennhardwoods.com
Whitechapel Ltd.	37	160	whitechapel-ltd.com
Wilke Machinery	45	161	wilkemach.com
Winfield Collection	94	162	thewinfieldcollection.com
Wood-Mizer	39	163	woodmizer.com
Woodcraft	14, 15	164	woodcraft.com
Woodline USA	12	165	woodbits.com
Woodprojects.com	94	166	woodprojects.com
Woodstock Int'l.	25	167	woodstockinternational.com
Woodworker's Book Club	Insert	—	woodworkersbookclub.com
Woodworker's Choice, The	21	168	thewoodworkerschoice.com
Woodworker's Supply	29	169	woodworker.com

NEW!

The Leigh FMT Mortise and Tenon Jig



Finally a jig designed to create mortise and tenons in one quick easy setup!

FMT features:

- Unique patented guide system
- Joints of any size from 1/2" x 5" down to a tiny 1/16" x 3/32"
- Use on matches or stock up to 3" x 5 1/2" (mortise) and 2 3/4" x 5 1/2" (tenon)
- Easy fingertip adjustment of joint tightness
- Make angled and compound angled joints
- Rout perfectly aligned double, triple and quadruple joints
- Use virtually any plunge router
- Uses 1/2" shank cutters
- Cam-action speed-clamps
- Integral dust port for vacuum

Call For Your Free Leigh FMT Brochure Today! 1-800-663-8932
 Leigh Industries Ltd., PO Box 357, Port Coquitlam, BC, Canada V3C 4K6
 Tel. 604 464-2700 Fax 604 464-7404 Web www.leighjigs.com



OSBORNE Wood Products, Inc.

Table Legs & More



Osborne Wood Products, Inc. offers an extensive line of dining table legs in a variety of wood species. Custom turnings are also available.

Call today or visit our website and order on-line

www.osbornewood.com

New Skirt Assemblies

Save Time!

Osborne now offers optional custom skirt assemblies on all its table legs, featuring mortise and tenon construction with pre-drilled sink holes -- shipped ready to assemble with corner brackets and hardware.

1816 Highway 123 North • Toccoa, GA 30577
 Call for a catalog: 1-800-746-3233
 Order line: 1-800-849-8876 • Español: 1-877-445-6034

Enjoyable Woodworking

Building Projects with Style, Ease, and Confidence!

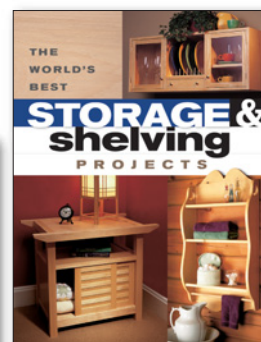
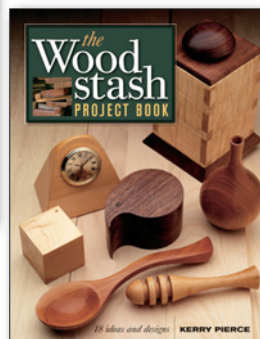
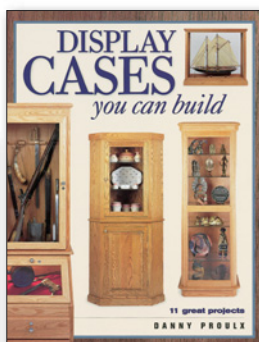

Cutting-Edge Table Saw Tips & Tricks

Kenneth Burton

Realize the full potential of your table saw — and make it the most versatile tool in your shop! You'll find dozens of tricks, techniques and jigs that ensure incredible results, every time. You'll also discover practical solutions to complex and seemingly impossible woodworking situations — helpful hints that make your every minute in the woodshop more effective and more fun.
#70569-K/\$24.99/128 p/pb

Design Your Own Furniture

Jim Stack

From start to finish, this comprehensive book will guide you through the entire process of furniture design! With the help of step-by-step instructions, detailed drawings, and 200 color photos, you'll learn how to create original projects that fit your specific needs.
#70555-K/\$24.99/128 p/pb

Display Cases You Can Build

Danny Proulx

Enjoy the satisfaction of putting your woodworking projects to use right away! This book contains step-by-step instructions, materials lists, and construction plans for 10 attractive cabinets that will show off your collectibles. Whether you need a large, room-dividing wall cabinet or a wall-mounted display case, you're sure to find a project to accommodate all your treasures!
#70547-K/\$24.99/128 p/pb

The World's Best Storage & Shelving Projects

Editors of Popular Woodworking Magazine

Straight from the pages of *Popular Woodworking* to you, we've hand-picked 22 of the most requested project plans. From quick and easy small pieces to large, elaborate designs, this book offers something for every woodworker. Plus, the large pictures, detailed cutting lists, and clear steps ensure successful completion of every project!
#70587-K/\$24.99/128 p/pb

The Wood Stash Project Book

Kerry Pierce

Don't throw away your leftover scraps of wood — find out how to turn them into great gifts! This book offers 18 creative projects that will make the most out of the wood surplus in your shop.
#70540-K/\$24.99/128 p/pb

www.popularwoodworking.com/store/books

For credit card orders, visit the Web site above or call 1-800-448-0912.

9 AM to 7 PM Monday-Friday, 9 AM to 6 PM Saturday

ORDER FORM

Item #	Quantity	Unit Price	Total Cost
<p>In the U.S., please add \$3.95 shipping and handling for the first book, \$1.95 for each additional book. In OH, NY, CO and MI please add applicable state tax. In Canada, add US\$5.00 for the first book, US\$3.00 for each additional book, and 7% GST. Payment in U.S. funds must accompany order.</p>			<p>Subtotal _____</p> <p>Tax _____</p> <p>Shipping & handling _____</p> <p>TOTAL ENCLOSED _____</p>

Check or money order enclosed - or -
 Charge my VISA MC AmEx Exp. _____
 Acct.# _____
 Signature _____
 Name _____
 Address _____
 City _____
 State/Prov. _____ ZIP/PC _____

Send to:  Popular Woodworking Books
 PO Box 9274
 Central Islip, NY 11722-9274

ZACO3PV

CAPTION THE CARTOON

Illustrated by Bob Rech
bobrech@juno.com

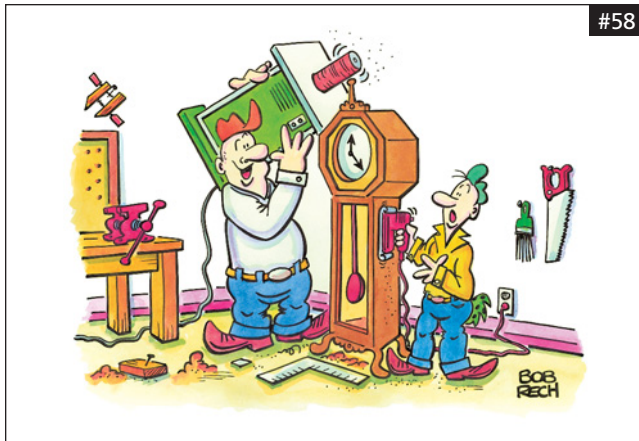

#58

We Now Take E-mail Entries!

Submit your captions for this cartoon by e-mailing them to cartoon@fwpubs.com (be sure to put "Cartoon Caption #58" as the subject of your e-mail) with your name, address and phone number. Or send it to us on a postcard: *Popular Woodworking*, Cartoon Caption #58, 4700 E. Galbraith Road, Cincinnati, OH 45236 by **April 30**. Winners will be chosen by the editorial staff.

This issue's winner receives the Makita 6317DWDE, MegaForce 12-volt cordless drill. This two-speed, 1/2"-chuck drill offers two 2.6 amp-hour nickel metal hydride batteries providing more than 300 in./lbs. of torque. It was recognized by *Popular Woodworking* as one of the best cordless drills available today. The runners-up each win a one-year subscription to *Popular Woodworking*.



Makita

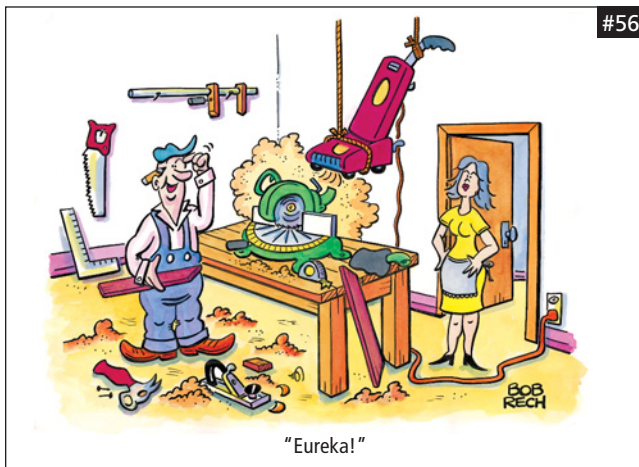

#56

"Eureka!"

Mark Wylie, of Ottawa, Ontario, is the winner of our Cartoon Contest from the December issue and recipient of the Freud jigsaw. The following runners-up each receive a one-year subscription to *Popular Woodworking*:

"Just eliminating some possibilities for my 'Tricks of the Trade' submission!"

Wes Zell, Charlottesville, Virginia

"I wonder if I can find some 1-micron bags online?"

Pete Lakers, Springfield, Oregon

"And that headlight comes in handy, too."

Ken Green, Gilbert, Arizona

WOODWORKER'S BOOK CLUB

The Only Book Club Exclusively For Woodworkers!

Join online today at
WoodWorkersBookClub.com

You'll discover:

- Hard-to-beat **SAVINGS** of 15-50% off publishers' list prices
- **FREE** shipping & handling
- **Easy ONLINE ORDERING**
- **Easy-to-earn FREE BONUS BOOKS**
- **Special WEB SITE-ONLY sales**
- **100% MONEY-BACK GUARANTEE**
- **And MORE!**

WOODWORKER'S BOOK CLUB

WoodWorkersBookClub.com

Colors to Dye For

Dye stains offer many advantages over traditional wiping stains and gel stains.

Just as in woodworking where you choose among tools to accomplish the task you want, you can choose among types of stain to get the look you want. I'm not talking about the color of the stain, which also is important, but rather the effect the stain has on the wood. There are three broad categories to choose from.

- Wiping stains are the most common stains and are available in every paint store and home center. These are liquid stains containing a binder – either oil- or water-based finish – that glues the colorant (pigment and/or dye) to the wood.

- Gel stains are also widely available and contain a binder, but these stains are thick like mayonnaise and are made with just a pigment colorant. They are most useful for avoiding blotching on tight-grained woods such as pine, cherry and birch, and for glazing (adding color) between coats of finish.

- Dye stains are not so widely available, but they're extremely useful for adding deep, rich and even coloration to wood no matter what the grain structure. These stains don't contain a binder, and this makes them more forgiving and easier to manipulate.

What are Dyes?

Dyes are colorants that can be natural (coffee, tea, berries and so on) or synthetic, which means "aniline" dyes derived from coal tar or petroleum. Aniline dyes are, by far, the most widely used dyes in wood staining because they are more lightfast (resistant to fading) than natural dyes, and they're available in a much wider range of colors – all colors, in fact, except white.

The main difference between dye and pigment is that dye dissolves in a liquid and pigment doesn't, so dye soaks into the wood along with the liquid while pigment just lodges



Dye stains are available in a wide variety of colors and are easy to mix at home. Best of all, you can easily add or remove color to your project using dyes, unlike pigment stains.

in pores and sanding scratches large enough to hold it. This means that dye will produce a much more even coloration on coarse-grained woods such as oak and ash, and a darker color on all woods without obscuring them. (Dye accentuates blotching, however, if the wood has a tendency towards it.)

Another difference is that dye, even aniline dye, fades more quickly than pigment, especially in direct sunlight. So you shouldn't use dye on outdoor projects or on projects that will sit next to a window.

Stains From Dye

Dye stains are available in powder and liquid form. Powder dyes dissolve in water, alcohol or petroleum distillate (paint thinner, naphtha, toluene or xylene) – the label will

tell you which. Liquid dyes are already dissolved in solvents and are ready to use, but the solvents evaporate quickly, which makes these dyes difficult to manipulate except by spraying and leaving the excess to dry.

If you intend to apply a dye stain by hand rather than spray, I recommend you use water-soluble dyes in powder form, because water is essentially free, it isn't toxic and it dries slower than organic solvents, so you have more working time. Water-soluble dyes are also among the most lightfast of the dyes.

I also recommend you use Lockwood dyes because of the wonderful colors available. (See Sources.) W. D. Lockwood Inc. began supplying dyes to the furniture industry in 1895 and the colors that were popular then were early American and old-English – the colors the wood had aged to after 100 years or more. These are the colors most woodworkers want for their projects, anyway, so the burden of mixing colors can be avoided.

To dissolve the dyes, simply stir the pow-

by Bob Flexner

Bob Flexner is the author of "Understanding Wood Finishing" and a contributing editor to Popular Woodworking.

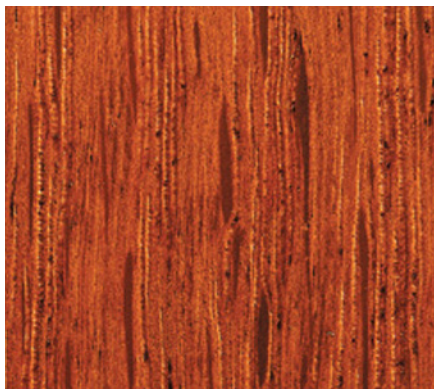

One of the disadvantages of a dye stain is that it doesn't get into the pores of open-grained wood, such as this piece of red oak.

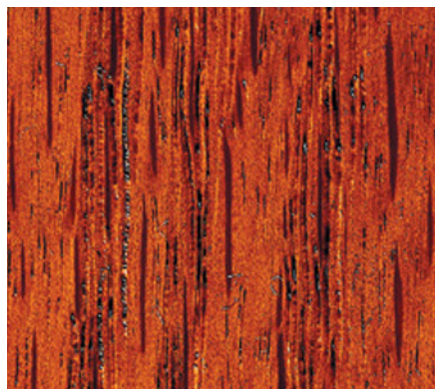

You can correct that easily by sealing the wood and then wiping on a similar colored wiping stain. When you wipe it all off, only the color in the pores will be darkened.

der into water. The powder will dissolve faster in hot water, but cold water also will work. Distilled water is best because there's no metal residue that can influence the color, but I've never had problems with tap water. Dissolve enough dye in the water to achieve the color intensity you want. You can always add more water or dye powder later, or you can manipulate the color right on the wood. You can blend colors of any brand of dye as long as the dye dissolves in water.

The one drawback of water-soluble dyes is that water raises wood grain. Because sanding after you've applied the dye may remove some of the color, it's usually best to wet the wood prior to applying the dye, let the wood dry and then sand it smooth with fine-grit sandpaper. Very little grain will then be raised when you apply the stain.

Applying Dye Stains

You apply dyes just as you do liquid wiping stains – by getting the entire surface wet with stain using a rag, brush or spray gun, and then wiping off the excess stain before it dries. If you do this, you'll always get an even coloring as long as the wood is clean (meaning there's no glue seepage or finish remaining after stripping) and not naturally blotchy.

The great application advantage of water-soluble dyes over stains containing a binder is that you can lighten or darken the color after the stain has dried because there's no binder gluing the dye to the wood. You lighten the color by wiping the surface with a wet cloth to redissolve the dye and lift some from the surface, and you darken the color by applying more dye.

You can also move the color to the red, green or yellow side by applying one of these colored dyes, or reduce the intensity of the color by applying black dye – without muddying the wood. And you can bleach most of the color out of the wood by applying household bleach.

All of this gives you great control of the final color, but you might find it worthwhile to practice a few times on scrap wood if you've never used dyes. Too heavy a dose of black, for example, will be very hard to correct.

Solving Problems

You may find that water-soluble dye doesn't get into the grain of coarse-grained woods such as oak. You can correct this easily by applying a similar colored, oil-based wiping stain over your first (sealer) coat and wiping off all the excess stain. The colorant will lodge in the grain and color it but won't affect the overall color.

Because water-soluble dye will redissolve when brought into contact with water, you shouldn't brush or wipe any water-based product over dye, because you'll drag the color and leave streaks. If you want to brush a water-based finish, apply a thin barrier coat of dewaxed shellac or thinned varnish first.

Also due to its lack of resistance to water, it's not wise to apply an oil finish over water-soluble dye because this finish is too thin to offer much protection. If any water gets through the finish, it will cause a light spot, which will be very difficult to fix.

Most manufacturers in the furniture industry and most skilled finishers use dye stains to advantage, and you can too – with just a little practice. **PW**

Many professionals use dye stains, which give you brilliant colors without obscuring the grain. This piece by Glen Huey, a contributing editor to this magazine, was colored using a dye stain.



SOURCES

W.D Lockwood, Inc.
81-83 Franklin St.
New York, NY 10013
866-293-8913
wdlockwood.com

Woodworker's Supply
1108 North Glenn Road
Casper, WY 82601
800-645-9292
woodworkers.com
(these are Lockwood dyes sold under the Moser label)

Plane Night

We'll take a thin, wispy shaving over a royal flush, strike or touchdown any day.

Some people have poker night, some bowl in a league once a week and some watch Monday night football religiously. But for one of my best friends and me, nothing is more relaxing than “plane night.”

I've been fascinated by tools for as long as I can remember. Around the age of eight, I recall finding a couple of my dad's planes in a workbench drawer. They were dull and clogged with shavings. After fiddling with these contraptions for a considerable amount of time, I gave up. Even with the cutter protruding an eighth of an inch, I still couldn't produce a shaving – no wonder my dad had them stashed in a drawer.

Those less-than-pleasant memories stayed with me for a long time. The planes on the color-coded tool racks in my high school shop weren't any better than the planes my dad owned. They were simply relics of a hazy past: wooden ships and iron men or some such nonsense. Looking at those planes, I was thankful for electricity.

After graduation, I started building some furniture for my own use. It was 1970, and I was in love with contemporary furniture and power tools. I was stuck in this rut for about three years. Things took a strange turn when I started working with a fellow named Frank. He was into woodworking too, but not my kind of woodworking. Frank liked antiques and restoring them. Oddly enough, we hit it off in fairly short order. I soon became intrigued with antiques, and we scoured yard sales together, searching for treasures on which to “hone” our skills.

We soon discovered that in order to accomplish our tasks, we needed to improve our hand-tool abilities and increase our hand-tool arsenals. We started haunting flea markets and auctions for tools. One of our almost simultaneous acquisitions was antique wooden jack planes. We hoped that these simple tools would perform better than complex metal planes. Acquiring these tools was

easy, the hard part was learning to sharpen and tune them. This was no small task, because in those days, information on setting up hand tools was not as readily available as it is now. Grinders and honing stones were added to our growing collections.

Somehow, we managed to get a decent edge on those old irons, and the night came to test our restored planes. We met at Frank's and headed for the basement. The first hour was filled with tedium. The initial hurdle was setting the iron. Tap the wedge too hard and the iron projected too far. Tap the heel and the iron would disappear into the body of the plane. But we were determined and fueled with desire (and a couple of beers), and soon we were taking shavings off of pine like nobody's business. Those shavings curled freely from the iron and the uncanny “snick-ing” sound of the sharp iron traveling over the wood made us giddy.

We were knee deep in shavings when Frank's wife, Patrice, came downstairs with some munchies to see what the “boys” were up to. I think she was impressed, and we even let her have a hand at it. We spent several hours making toothpicks that night and as I was leaving, Patrice asked when our next “plane night” was going to be. From that point on, these encounters have always been referred to as “plane night.”



We get together a couple of times a month now, and our “plane nights” don't occur as frequently as they did in those early years. Now that we know what we're doing, we actually use the tools on real projects. Often, we are working on a project together and the evening will turn into a spontaneous “plane night.” Many times we will be in the middle of tuning a plane or just making shavings and, sensing that we are odd, wonder how many other people in the world might be doing precisely the same thing.

Nearly 30 years have passed since then, and we have progressed. From Stanley #4s to the daunting #55, rabet planes and compass planes, we have tuned and used them all. Our sharpening techniques have changed and improved. We have far more planes than any man has a right to own, and we continue to buy more. Sometimes, we pull those old wooden jack planes off of the shelf and try them out for old time's sake. Many things have changed for us throughout the years, but there is nothing that we enjoy more than a good, old-fashioned “plane night.” **PW**

Craig Bentzley is a woodworker, writer and demonstrator residing in southeastern Pennsylvania. His friends think he's just “plane” crazy.

CRAFTSMAN HELPED RESTORE THE STATUE OF LIBERTY. WE ALSO DO PROJECTS THAT COST \$230 MILLION LESS.

In 1981, a special committee assessed the condition of the Statue of Liberty. What they found was not encouraging. After greeting visitors to our nation's shore for more than ninety-five years, iron oxidation had leaked through the

exterior seams and had run down the surface. Inside, corrosion had gnawed away at the iron framework. In fact, the statue's torch could no longer safely support the weight of tourists and had to be closed. But after five years of meticulous renovation by a team of specialized iron and metal workers from France



and the United States who worked long hours with the help of Craftsman® tools, our country welcomed back the Lady who had welcomed so many. Poetically, it was July 4th, 1986—her centennial

birthday. Now while you may not be faced with such a demanding project, you may still find that the Craftsman Professional Mini-T Drill fits the bill. It's small and lightweight

The Mini-T Drill. It's small, but can take on a job of just about any size.



and goes places other drills can't. Like in between studs, behind refrigerators and under decks. That's because we put a 3.2 amp motor in its handle, reducing the profile to a measly 4.75 inches. And the handle is built with a no-slip vibration-dampening cushion. So drill into copper, steel or any other tough

material, if you want. The Mini-T Drill's up for it. Craftsman—available at Sears, Sears Hardware Stores and online at craftsman.com. Since 1927, we've been helping Americans get the job done right. No matter what size the project may be.

SEARS
Where else?™

CRAFTSMAN®
MAKES ANYTHING POSSIBLE®

DON'T JUST IMAGINE IT ROUT IT!

with Viper® Carbide Router Bits

Over 400 profiles to choose from



Straight

Forming



Grooving



Laminate & Trim



Bring out the beauty of the wood in your projects. Signs, picture frames, moldings, furniture, cabinet doors. Simple or complex, if you can imagine it, you can rout it with Viper router bits. With finely honed RazorSmooth carbide edges, high-strength brazing, precisely machined anti-kick bodies and anti-stick coating, Viper consistently delivers clean, smooth, burn-free cuts. And Viper bits are made with care in West Jefferson, NC, by folks who know woodworking.

T h e A r t o f R o u t i n g